

HAM RADIO HORIZONS

AMATEUR RADIO'S
CHANGING
AND SO ARE
WE

MAY 1980 / \$1.50

Introducing
K5FUV's DX
Horizons column

Meet the man
behind the new
FCC exams:
Jay Jackson,
AF4O

New tricks for
an old friend:
An interesting
recipe for the
813

Illustrated guide
to making your
own PC boards

US
Odyssey
Questions
and Answers
and more

easy-to-build,
versatile keyer



Move over imports, here's the new TEN-TEC

DELTA

the notable change in hf transceivers



All new, all **nine** hf bands and only \$849!

DELTA — the symbol of change—the name of a great new TEN-TEC transceiver. A transceiver for changing times, with new features, performance, styling, size and value.

TOTAL SOLID-STATE. By the world's most experienced manufacturer of hf solid-state amateur radio equipment.

ALL 9 HF BANDS. First new transceiver since WARC. 160-10 Meters including the three new hf bands (10, 18 & 24.5 MHz). Ready to go except for plug-in crystals for 18 and 24.5 MHz segments (available when bands open for use).

SUPER RECEIVER. New, low noise double-conversion design, with 0.3 μ V sensitivity for 10 dB S+N/N.

HIGH DYNAMIC RANGE. 85 dB minimum to reduce overload possibility. Built-in, switchable, 20 dB attenuator for extreme situations.

SUPER SELECTIVITY. 8-pole monolithic SSB filter with 2.4 kHz bandwidth, 2.5 shape factor at 6/60 dB points. And optional 200 Hz and 500 Hz 6-pole crystal ladder filters. Eight pole and 6-pole filters cascade for 14 poles of near ultimate skirt selectivity. Plus 4 stages of active audio filtering. To sharpen that i-f response curve to just 150 Hz bandwidth. 4-position selectivity switch.

BUILT-IN NOTCH FILTER. Standard equipment. Variable, 200 Hz to 3.5 kHz, with notch depth down to -50 dB. Wipes out interfering carriers or CW.

OFFSET TUNING. Moves receiver frequency up to ± 1 kHz to tune receiver separately from transmitter.

"HANG" AGC. For smoother, clearer, receiver operation.

OPTIONAL NOISE BLANKER. For that noisy location, mobile or fixed.

WWW RECEPTION. Ready at 10 MHz.

"S"/SWR METER. To read received signal

strength and transmitted standing wave ratio. Electronically switched.

SEPARATE RECEIVER ANTENNA JACK. For use with separate receiving antenna. linear amplifier with full break-in (QSK) or transverters.

FRONT PANEL HEADPHONE AND MICROPHONE JACKS. Convenient.

DIGITAL READOUT. Six 0.3" red LEDs.

BROADBAND DESIGN. For easy operation. Instant band change—no tuneup of receiver or final amplifier. From the pioneer, TEN-TEC.

SUPER TRANSMITTER. Solid-state all the way. Stable, reliable, easy to use.

200 WATTS INPUT. On all bands including 10 meters (with 50 ohm load). High SWR does not automatically limit you to a few watts output. Proven, conservatively rated final amplifier with solid-state devices warranted fully for the first year, and pro-rata for five more years.

100% DUTY CYCLE. All modes, with confidence. 20 minutes max. key-down time. Brought to you by the leader in solid-state finals, TEN-TEC.

QSK — INSTANT BREAK-IN. Full and fast, to make CW a real conversation.

BUILT-IN VOX AND PTT. Smooth, set-and-forget VOX action plus PTT control. VOX is separate from keying circuits.

ADJUSTABLE THRESHOLD ALC & DRIVE. From low level to full output with ALC control. Maximum power without distortion. LED indicator.

ADJUSTABLE SIDETONE. Both volume and pitch, for pleasant monitoring of CW.

SUPER STABILITY. Permeability tuned VFO with less than 15 Hz change per F° change over 40° range after 30 min. warmup—and

less than 10 Hz change for 20 Volt AC line change with TEN-TEC power supply.

VERNIER TUNING. 18 kHz per revolution, typical.

SUPER AUDIO. A TEN-TEC trademark. Low IM and HD distortion (less than 2%). Built-in speaker.

SUPER STYLING. The '80s look with neat, functional layout. "Panelized" grouping of controls nicely human engineered for logical use. New, smaller size that goes anywhere, fixed or mobile (4 $\frac{3}{4}$ "h x 11 $\frac{1}{2}$ "w x 15"d). Warm, dark front panel. Easy-to-read contrasting nomenclature. Black "clam-shell" aluminum case. Tilt bail.

MODULAR/MASS-TERMINATION CONSTRUCTION. Individual circuit boards with plug-in harnesses for easy removal if necessary. Boards are available.

FULL ACCESSORY LINE. All the options: Model 282 200 Hz CW filter \$50; Model 285 500 Hz CW Filter \$45; Model 280 Power Supply \$139; Model 645 Dual Paddle Keyer \$85; Model 670 Single Paddle Keyer \$34.50; Model 247 Antenna Tuner \$69; Model 234/214 Speech Processor & Condenser Microphone \$163; Model 215 PC Ceramic Microphone \$34.50; Model 283 Remote VFO; Model 287 Mobile Mount, and Model 289 Noise Blanker available soon.

Experience The Notable Change In HF Transceivers. Experience DELTA. See your TEN-TEC dealer or write for full details.

 **TEN-TEC, INC.**
SEVIERVILLE, TENNESSEE 37862
EXPORT 3715 LINCOLN AVE. CHICAGO, ILL. 60646

WILSON SYSTEMS, INC.

the SYSTEM 36

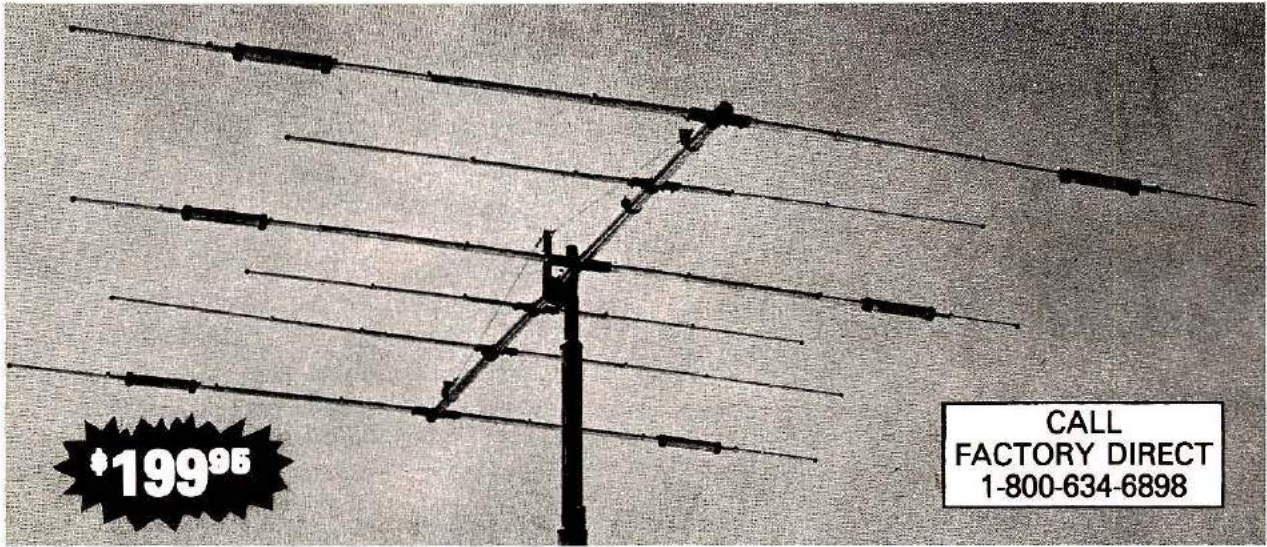

\$199⁹⁵

**CALL
FACTORY DIRECT
1-800-634-6898**

A trap loaded antenna that performs like a monobander! That's the characteristic of this six element three band beam. Through the use of wide spacing and interlacing of elements, the following is possible: three active elements on 20, three active elements on 15, and four active elements on 10 meters. No need to run separate coax feed lines for each band, as the bandswitching is automatically made via the High-Q Wilson traps. Designed to handle the maximum legal power, the traps are capped at each end to provide a weather-proof seal against rain and dust. The special High-Q traps are the strongest available in the industry today.

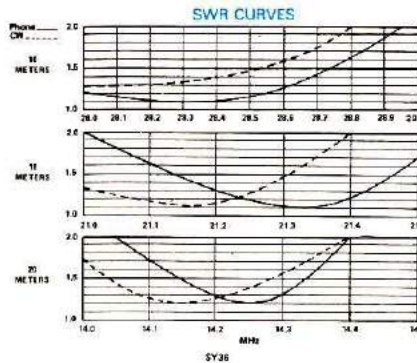

SPECIFICATIONS

- Band MGz 14-21-28
- Maximum power input Legal Limit
- Gain (dBd) 9 db
- VSWR @ resonance 1.3:1
- Impedance 50 ohm
- F/B Ratio 20 db or Better
- Boom (O.D. x Length) 2" x 24' 2 1/2"
- No. of Elements 6
- Longest Element 28' 2 1/2"
- Turning Radius 18' 6"
- Maximum Mast Diameter 2"
- Surface Area 8.6 sq. ft.
- Matching Method Beta
- Wind Loading @ 80 mph 215 lbs.
- Maximum Wind Survival 100 mph
- Feed Method Coaxial Balun (supplied)
- Assembled Weight (approx.) 53 lbs.
- Shipping Weight (approx.) 62 lbs.

Compare the SY-36 with others . . .

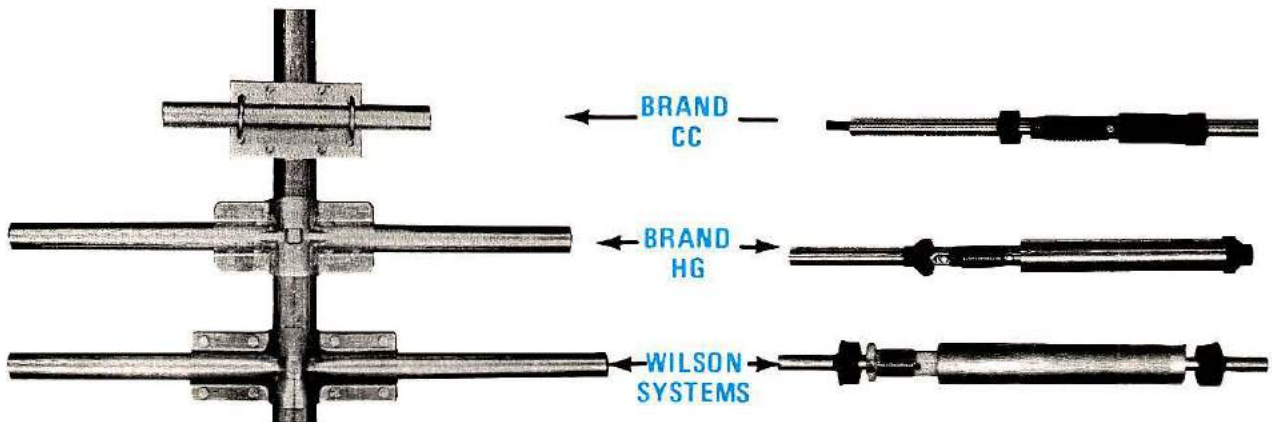

Compare the size and strength of the boom to element clamps. See who offers the largest and heaviest duty. Which would you prefer?

Wilson Systems traps offer a larger diameter trap coil and a larger outside housing, giving excellent Q and power capabilities.

**CALL
FACTORY DIRECT
1-800-634-6898**

**W S I WILSON
SYSTEMS, INC.**
4286 S. Polaris Ave., Las Vegas, Nevada 89103

Prices and specifications subject to change without notice.

THIS MONTH'S

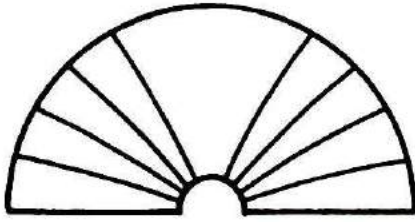

HORIZONS

A Keyer You Can Build

Modern technology has condensed electronic keyers with virtually hundreds of circuit elements into a mere handful of components, an IC or two, and a small enclosure to hold the whole assembly. Here's a complete, compact keyer that provides all the modern features, runs on battery power, and requires only one external wire — a keying line to the transmitter. Author Powell tells you about it, starting on page 12, so gather up some parts and have a pleasant weekend putting it together.

VHF Odyssey

Here's the story of a California ham who decided vhf operating is more fun on the East Coast than on the West Coast, and went to ridiculous lengths to prove it!

Amateur Station Arrangement for Communications Efficiency

The second of a two-part article by Doug Blakeslee, N1RM, on tying your station together for appearance and operating convenience. How to use low and high impedance microphones; the best speaker arrangement for communications use; an audio filter; and how to tie in a monitor scope — plus more.

The Hero

Not all heros are remembered in the history books, or have been decorated with medals for their works. However, the crew of an Italian dirigible, lost on a North Pole expedition, will not forget the radio operator who

stayed by his key in the face of cold, lack of supplies, and failing batteries. Intriguing reading about an early use of radio to save lives.

Making Your Own PC Boards

Does state-of-the-art circuitry scare you? It's not really that rough, when you get the hang of things. The best way to overcome your fear of the unknown is to first understand how it works, then build a sample project to prove you can do it. Authors Smith and Kates provide both the lesson and the example, starting on page 36.

Testing Semiconductors With A VOM

Specialized instruments for testing all manner of semiconductors are nice, and impressive oscilloscopes and curve tracers are better, but you probably have a basic instrument in your shop or shack that will do the job very well. It's the ham's pal, the volt-ohm-milliammeter, known to most as the VOM. K3BY tells how to use it, provides some charts of hook-up information, and tells you how to identify the polarity of your VOM's leads before you start. All good stuff, starting on page 42.

Ham Radio Techniques

In his column for this month, Bill Orr revives an old amplifier — the 813 — and adapts it for modern grounded-grid service. Surplus or flea-market tubes? He has a few hints to help you find a good one, or reject some that are ornaments only. There's also a circuit to help your solid-state transceiver more effectively communicate with linear amplifiers.

DX Horizons

It's here — the *Ham Radio Horizons* DX Column is up and running, as the computer buffs say, and K5FUV's look at this fascinating part of Amateur Radio provides some background on the stations you'll work or have worked; who they are, how they got to that rare spot, and whether they are likely to stay there. Included are operating tips, frequencies, where to send QSLs, photographs, and other choice bits of information to

make your DXing more successful, and to introduce those wonderful people at the other end of a DX contact. You'll find it on page 52.

The FCC Answers Some Questions

Many of you will remember WB6NOA from his past *Horizons* articles where he explored hamming from such places as hot-air balloons, racing sailboats, and the torrid depths of Death Valley. Turning his attention to more serious things, Gordon braved the Washington jungle and found the man who could answer some questions about the new Amateur exams and the study syllabus for them (the complete syllabus was printed in last month's *Ham Radio Horizons*). In this interview with Jay Jackson of the FCC, you'll gain some insight about the style and intent of the new material. Whether you are going to try for your first ticket, or will go for the next higher class of license, you'll enjoy the session, starting on page 56.

The Cover

A few components, a pc board, a Curtis IC, and a neat cabinet are the basic ingredients of this versatile keyer, and you can put it together in a weekend. The self-contained package is fun to use, as well. The story starts on page 12. Photograph by Ed Crabtree.

HAM RADIO HORIZONS May 1980, Volume 4, Number 5. Published monthly by Communications Technology, Inc., Greenville, New Hampshire 03048. Telephone (603) 878-1441. Second Class Postage paid at Greenville, New Hampshire and at additional mailing offices. ISSN 0147-8818.

Subscription price: Domestic, one year, \$12.00; two years, \$20.00; three years, \$27.00. Canada and Worldwide, one year, \$12.00; two years, \$22.00; three years, \$30.00, payable in United States funds.

Subscription inquiries and changes of address should be directed to *Ham Radio Horizons*, Greenville, New Hampshire 03048. Please include address label from most recent issue if possible.

MFJ SUPER CW/SSB FILTERS



\$59⁹⁵

MFJ-721

MFJ-721 SUPER SELECTOR CW/SSB FILTER gives 80 Hz BW, steep SSB skirts, noise limiting.

CW Filter gives 80 Hz BW. No ringing. 8 poles give super steep skirts (60 dB down one octave from center freq. of 750 Hz). No tunable filter can match performance. BW: 80, 110, 150, 180 Hz. Reduces noise up to 15 dB.

SSB Filter improves readability. Reduces splatter, hiss, static, noise, hum. IC active filter has 375 Hz highpass cutoff; 2.5, 2.0, 1.5 KHz (36 dB/octave) lowpass cutoffs.

Works with any rig. AM, SSB, CW. Plugs into phone jack. 2 watts for speaker. Inputs for 2 rigs. Speaker and phone jacks. Phones disable speaker. OFF bypasses filter. 9-18 VDC, 300 ma. 5x2x6 inches. Optional AC adapter, \$7.95.

Switchable noise limiter for impulse noise; trough clipper removes background noise.

Simulated stereo for CW lets ears, brain reject QRM. Yet, hear off frequency calls.

Tunable Filter Instantly zero in SSB/CW signals with tunable peak, notch, lowpass filter.



\$59⁹⁵

MFJ-751

MFJ-751. Peak, notch or lowpass signals, zero in with freq. control, adjust bandwidth for minimum QRM. Double tuned for extra steep skirts.

Linear freq. control tunes 300 to 3000 Hz. Output is constant as bandwidth is varied flat to 40 Hz. Tight notch to 70 db. 5x2x6 in.

Hear off frequency calls with simulated stereo.

Works with any rig. Plugs in phone jack. 2 watts for speaker. 110 VAC or 9-18 VDC, 300 ma. One year unconditional guarantee.

MFJ-721 has 4 CW stages for super steep skirts. Best for CW. **MFJ-751** is best for general use when versatility is more important.

Order from MFJ and try it. If not delighted return within 30 days for refund (less shipping). One year unconditional guarantee. **Order today. Call toll-free 800-647-1800,** charge VISA, MC. Or mail check, money order. Add \$3.00 shipping.

CALL TOLL FREE ... 800-647-1800

Call 601-323-5869 for technical information, order/repair status. Also call 601-323-5869 outside continental USA and in Mississippi.

MFJ ENTERPRISES, INC.
BOX 494, MISSISSIPPI STATE, MS 39762

MFJ SHORTWAVE ACCESSORIES

NEW Indoor Tuned Active Antenna. Rivals, can even exceed reception of outside long wire.

Rivals long wires

\$79⁹⁵

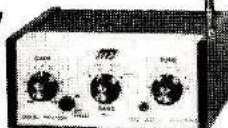

MFJ-1020 NEW INDOOR ACTIVE ANTENNA sits on your desk ready to listen to the world. Rivals, can even exceed reception of outside long wire. Unique **Tuned Active Antenna** minimizes intermod, provides RF selectivity, reduces noise outside tuned band. Also use as preselector for external antenna. Covers 300 KHz to 30 MHz in five bands. Adjustable telescoping antenna. Controls: Tune, Band Selector, Gain, On-Off/Bypass. LED. FET, bipolar circuitry. 110 VAC, 9-12 VDC or 9 V battery for portable use. Phono jack for external ant. 5x2x6 in.



\$99⁹⁵

MFJ-1040 RECEIVER PRESELECTOR. Improves weak signal reception, rejects out-of-band signals, reduces image response, 1.8 to 54 MHz. Up to 20 db gain. Low noise MOSFET. Gain control. Bandswitch. Can use 2 ant., 2 rcvrs. ON-OFF/Bypass. 20 db attenuator. LED. Coax, phono jacks. 110 VAC or 9-18 VDC, 8x2x6 in. Also for XCVRS to 350 watts input. Auto bypass. Delay control. PTT jack. **MFJ-1045, \$69.95.** Same as MFJ-1040, less attenuator, xcvr auto bypass, delay control, PTT. Use 1 ant., 1 rcvr. 5x2x6 in. 9 V bat., 9-18 VDC or 110 VAC with optional AC adapter, \$7.95.

\$89⁹⁵

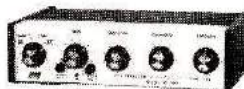

MFJ-959 RECEIVER ANTENNA TUNER has low noise 20 db preamp for weak stations. Match antenna to receiver for maximum signal. 1.6 to 30 MHz. Can use 2 ant., and 2 rcvrs. Select tuner, tuner with preamp, tuner with 20 db attenuator, bypass. Gain control. Coax, phono jacks. 110 VAC or 9-18 VDC. 9x2x6 in. **MFJ-950, \$59.95.** Same as MFJ-959, less preamp, attenuator, bypass. 6x2x6 in.

MFJ-751 Tunable AM/SSB/CW Filter, \$59.95. MFJ-200 Freq. Std., \$29.95, more. **Free catalog.**

Order from MFJ and try it. If not delighted, return within 30 days for refund (less shipping).

One year unconditional guarantee.

Order yours today. Call toll free 800-647-1800. Charge VISA, MC. Or mail check, money order. Add \$4.00 each for shipping and handling.

CALL TOLL FREE ... 800-647-1800

Call 601-323-5869 for technical information, order/repair status. Also call 601-323-5869 outside continental USA and in Mississippi.

MFJ ENTERPRISES, INC.
BOX 494, MISSISSIPPI STATE, MS 39762

MFJ SWR/ WATTMETERS

NEW Multi-Sensor SWR/Peak Reading Wattmeter. Operate 2 rigs simultaneously:

HF, VHF, QRP.

\$119⁹⁵

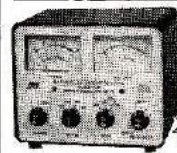

MFJ-825 Deluxe Power Sentry is MFJ's exclusive Multi-Sensor SWR/PEAK Wattmeter.

Plug in any 2 sensors: HF, VHF, or QRP (see specs below). Switch selects one of two. Comes with one sensor of your choice. Use remote or mount in cabinet.

Operate 2 rigs simultaneously or alone. Switch selects rig to monitor.

Forward/reflected power in 2 ranges. Dual meters, 2% movements. Peak or average power.

Read SWR directly of either rig from 1:1 to 6:1. Has SWR sensitivity control.

Switch selects sensor A or B or grounds sensors for protection in transit and from minor static discharges.

Lighted meters, battery check. Black steel cabinet. 6-3/4 x 5-3/8 x 5-3/4 inches. 9 V battery or 110 VAC with optional AC adapter, \$7.95.

\$69⁹⁵

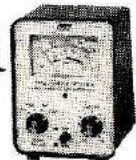

The NEW MFJ-820 Power Sentry is MFJ's exclusive Multi-Sensor SWR/Wattmeter.

Plug-in sensors for HF, VHF, and QRP (see specs below). Comes with one sensor of your choice. Use remote or mount in cabinet.

Monitor forward/reflected average power, 2 ranges. SWR 1:1 to 6:1. 2% meter movement.

Has range/mode, reflected/forward power switches, SWR sensitivity control.

Lighted meter (requires 12 V). Rugged black steel cabinet. 3-7/8 x 5-3/8 x 4-1/2 inches.

PLUG-IN SENSORS: HF, VHF, QRP. \$29.95 EACH.

Plug up to two in MFJ-825, one in MFJ-820.

MFJ-830 HF SENSOR. 1.8 to 30 MHz. 200 and 2000 watts forward, 20 and 200 watts reflected power, full scale. 5 watt SWR sensitivity.

MFJ-831 VHF SENSOR. 50 to 175 MHz. 20 and 200 watts full scale forward and reflected power. 5 watt SWR sensitivity.

MFJ-832 QRP SENSOR. 1.8 to 30 MHz. 2 and 20 watts full scale forward and reflected power. 500 milliwatt SWR sensitivity.

Aluminum cabinet. SO-239. 2-1/2 x 2-5/8 x 2-1/4 inches. Remote or mount in meter cabinet.

Order from MFJ and try it. If not delighted, return within 30 days for refund (less shipping).

One year unconditional guarantee.

Order yours today. Call toll free 800-647-1800. Charge VISA, MC. Or mail check, money order. Add \$4.00 each for shipping and handling.

CALL TOLL FREE ... 800-647-1800

Call 601-323-5869 for technical information, order/repair status. Also call 601-323-5869 outside continental USA and in Mississippi.

MFJ ENTERPRISES, INC.
BOX 494, MISSISSIPPI STATE, MS 39762

WILSON SYSTEMS, INC. PRESENTS . . . THE NEW SYSTEM 40 TRIBANDER

3 MONOBAND ANTENNAS IN ONE-EACH WITH FULL MONOBAND PERFORMANCE

FACTORY DIRECT
ONLY

\$299⁹⁵

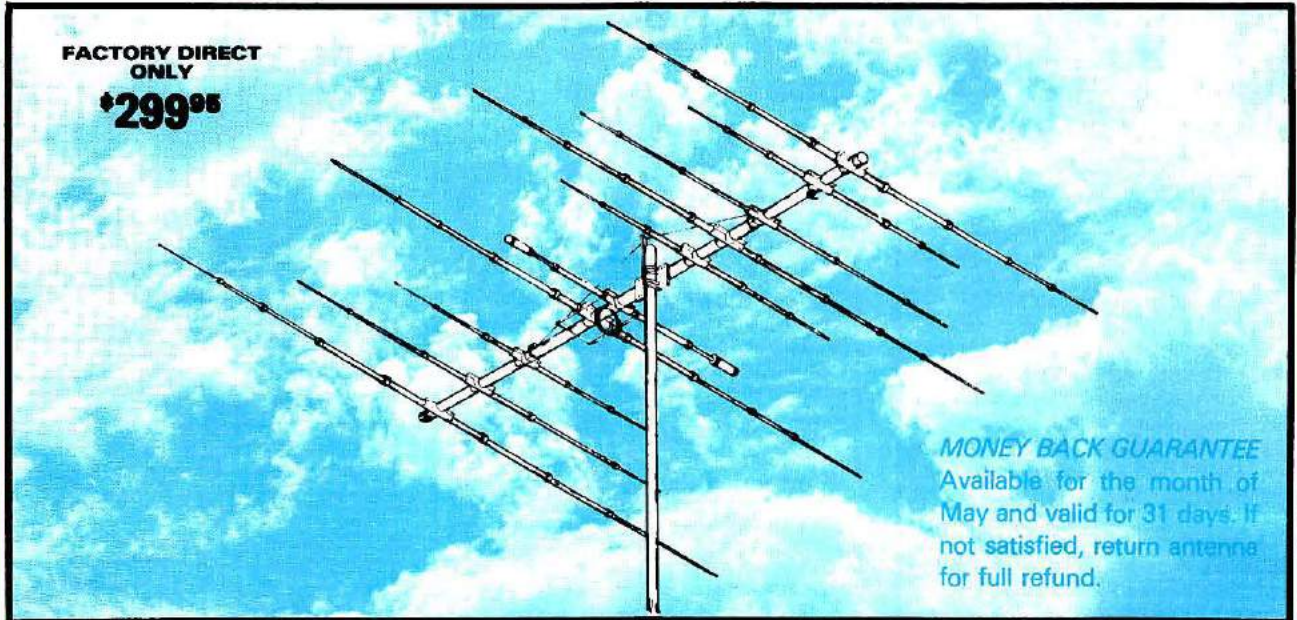

MONEY BACK GUARANTEE
Available for the month of
May and valid for 31 days. If
not satisfied, return antenna
for full refund.

A NEW CONCEPT IN ANTENNA DESIGN USING A 26 FT. BOOM

- FOR THE SERIOUS DXer WHO WANTS MONOBANDERS ON 10-15-20
- FOUR FULL SIZE 20 MTR ELEMENTS WITH 10 dbd GAIN
- THREE WIDE SPACED 15 MTR ELEMENTS WITH 8.2 dbd GAIN
- FOUR WIDE SPACED 10 MTR ELEMENTS WITH 10.2 dbd GAIN
- ONLY ONE FEED LINE REQUIRED
- DESIGNED WITH NO INTERACTIONS BETWEEN ELEMENTS
- ALL PARASITIC ELEMENTS ARE FULL SIZE
- BROADBAND — NO SEPARATE SETTINGS REQUIRED FOR PHONE OR CW
- SAME QUALITY HARDWARE AS USED IN ALL WILSON ANTENNAS

— SPECIFICATIONS —

Max. Pwr. Input	Legal Limit	Longest Element	36"
VSWR @ Res	1.2:1	Turning Radius	22' 6"
Impedance	50 ohm	Surface Area	12.1 sq. ft.
Feed Method	Coax Balun Supplied	Wind Loading @ 80 mph	309 lbs.
Matching Method	Modified Beta	Assem. Weight	75 lbs.
F/B Ratio	25 db	Shipping Weight	84 lbs.

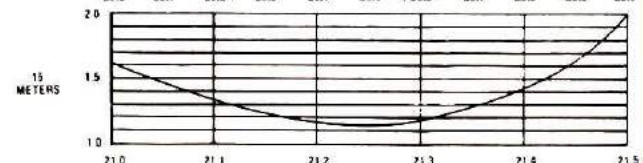
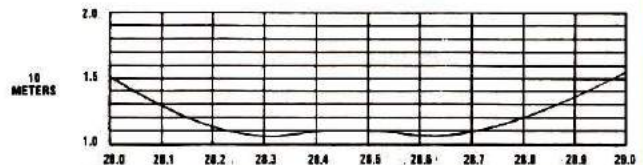
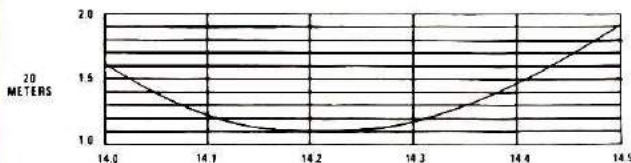

AVAILABLE ONLY
FACTORY DIRECT

CALL

1-800-634-6898 TOLL FREE

**W S I WILSON
SYSTEMS, INC.**

4286 S. Polaris, Las Vegas, Nevada 89103

PRICES AND SPECIFICATIONS SUBJECT TO CHANGE WITHOUT NOTICE.

May, 1980
Volume 4, Number 5

HAM RADIO HORIZONS

CONTENTS

T.H. Tenney, Jr., W1NLB Publisher	An Easy-To-Build Keyer 12
James R. Fisk, W1HR Editor-in-Chief	Kenneth E. Powell, WB6AFT
Editorial Staff	A VHF Odyssey 18
Thomas F. McMullen, Jr., W1SL Managing Editor	Wayne E. Overbeck, N6NB
Martin Hanft, WB1CHQ Administrative Editor	Station Interfacing, Part 2 24
Robert Schneider, N6MR	Douglas A. Blakeslee, N1RM
Joseph J. Schroeder, W9JUV	The Forgotten Hero 30
Alfred Wilson, W6NIF Assistant Editors	Henry Morrison, Jr., W5RIY
W.E. Scarborough, Jr., KA1DXQ Production Manager	Processing PC Boards 36
Publishing Staff	James R. Kates, WB8TCC
J. Craig Clark, Jr., N1ACH Assistant Publisher	Norman P. Smith, WA6ABD
Advertising Manager	Testing Semiconductor Devices 42
James H. Gray, W1XU Assistant Advertising Manager	Sam Guccione, K3BY
Susan Shorrock Circulation Manager	Ham Radio Techniques 47
	William I. Orr, W6SAI
	DX Horizons 52
	William E. Kenamer, K5FUU
	Inverview at the FCC 56
	Gordon V. West, WB6NOA
	Questions and Answers 60
	Activities Calendar 76
	Ad Check 78
	Ad Scan 71
	Advertiser's Index 78
	Benchmarks 63
	DX Column 52
	DX Forecaster 74
	Focus and Comment 8
	Ham Radio Techniques 47
	Horizons Locator 72
	Newsline 11
	Product Showcase 65
	Propagation Chart 75
	Questions and Answers 60
	This Month's Horizons 2
	The View From Here 6

Cassette tapes of selected articles from *Ham Radio Horizons* are available to the blind and physically handicapped from Recorded Periodicals 919 Walnut Street, 8th Floor Philadelphia, Pennsylvania 19107

Microfilm copies are available from University Microfilms, International Ann Arbor, Michigan 48103

Copyright 1980 by Communications Technology, Inc. Title registered at U.S. Patent Office

Ham Radio Horizons is published monthly by Communications Technology, Inc Greenville, New Hampshire 03048 Telephone 603-878-1441 ISSN 0147-8818



THE VIEW FROM HERE

Jamming and intentional interference have become more and more of a problem for Radio Amateurs over the past few years, and not only here in the United States, but overseas as well. It was recently reported by a Brazilian Radio Amateur that a malcontent in Sao Paulo delights in broadcasting old Nazi speeches over the local vhf repeater; and English users of the GB3LO repeater in London are continually bothered by the "squeekies" (named after one persistent jammer who always speaks in falsetto).

I suspect most American hams have heard about the "W6JAM" operator who was finally caught in Southern California, and the operator in Colorado who called "CQ DX" incessantly on W2LTP's 40-meter "HHH Net" before being nailed by FCC investigators. These contemptuous characters, unfortunately, represent only the tip of the iceberg, and for each one the authorities manage to shut down, two more crawl out from under a nearby rock. It's becoming more and more obvious that the FCC monitoring stations don't have the resources to solve this problem for us, so we must do a large part of the work ourselves.

I would like to suggest that the army of ARRL Official Observers and Intruder Watchers provide a ready resource of trained manpower who already have much of the equipment necessary for tracing down intentional interference on the high-frequency amateur bands. On 10, 15, and 20 meters good sharp beam antennas should be adequate for localizing interference; then it would be up to closer-in stations to pinpoint the trouble-maker.

Specialized direction-finding antennas would be required on 80 and 40 meters for good results, but these antennas are described extensively in the engineering literature. Indeed, entire textbooks have been written on the subject of radio direction finding (RDF), so it's not a topic that's been neglected. In fact, much of the research work was actually done back in the 1930's and many of the techniques and antennas were put to work during the war.

If you question the ability and speed with which a good RDF operator can locate an offending transmitting station, consider the high mortality rate among underground radio operators in Europe during the war; few survived, even though they kept their transmissions short and often changed operating frequency. By comparison, the cretins we're looking for are ill trained and disorganized; they should be duck soup for a well structured network of RDF enthusiasts.

A very important ingredient in this setup would be a control station who could coordinate all the activities of the network and plot the beam headings of the DF stations to obtain a fix. If each of the RDF stations had a small home computer programmed to do direction-finding work, and the computers were in direct communication on the ham bands (with ASCII, of course), it would be possible to determine the general location of a jamming station within a few seconds after he came on the air. Once his general location had been found, mobile stations could be called into action. Depending on the boldness of the jammer, it should be possible, within a few hours, to catch him in the act. I don't think we would have to catch very many before the rest of the misanthropes would crawl back under their rocks.

Jim Fisk, W1HR
editor-in-chief

FM...SSB...CW...

ICOM Does it All!



ICOM IC-260A

Enjoy VHF mobile at its best. Sideband, FM or CW, the ICOM IC-260A does it all. The ICOM IC-260A contains all the features a mobile operator would want in a compact 2 meter mobile package with FM, SSB, CW operation. Features customers ask for most including:

- 3 memories built in (quick access to your favorite frequencies).
- Memory scan — automatically stops on an active frequency programmed in the memories.
- Programmable band scan — scan the whole band, or any portion of it you desire (adjustable scanning speed).
- Squelch on SSB: the 260A will automatically and silently scan the SSB portion of the band seeking out the SSB activity on 2.
- 600kc repeater offset built in. Easy repeater operation on the FM portion of the band.
- Variable repeater split — with the 2 built in VFOs, it's possible to work the odd splits plus accommodate future repeater band plan changes.
- Multimode operation — USB, LSB, CW, and FM. Great for getting into OSCAR, plus enjoying SSB rag chewing as well as repeater operation (including the new subband).
- With optional 117/12V supply, the 260A makes a flexible functional base for SSB/OSCAR/FM operation

The RF amplifier and first mixer circuits using excellent Cross Modulation and Intermodulation characteristics. The IC-260A has excellent sensitivity demanded especially for mobile operation, high stability, and with Crystal Filters having high shape factors, exceptional selectivity.

The transmitter uses a balanced mixer in a single conversion system, a band-pass filter and a high-performance low-pass filter. This system provides distortion-free signals with a minimum spurious radiation level.

HF/VHF/UHF AMATEUR AND MARINE COMMUNICATION EQUIPMENT



ICOM

ICOM AMERICA, INCORPORATED

Sales Service Centers located at:

2112 116th Avenue NE
Bellevue, WA 98004
Phone (206) 454-8155

3331 Towerwood Dr., Suite 307
Dallas, TX 75234
Phone (214) 620-2780

ICOM INFORMATION SERVICE

2112 116th Ave., N.E.
Bellevue, WA 98004

Please send me: IC-260A specifications sheet; full color ICOM Product Line Catalog; List of Authorized ICOM Dealers.

NAME _____ CALL _____

ADDRESS _____

CITY _____ STATE _____ ZIP _____

You may send a machine copy of this form

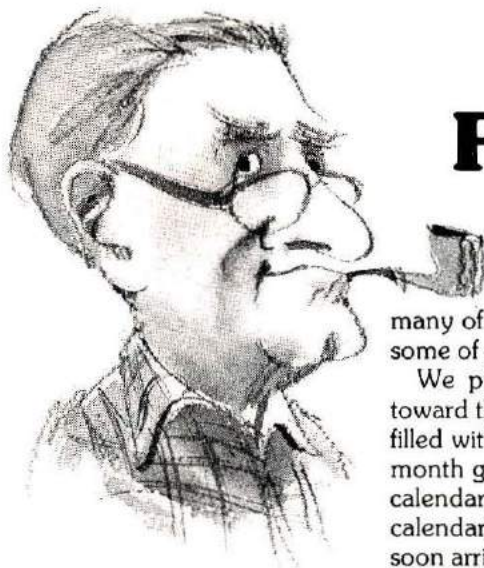

FOCUS & COMMENT

I'll take a few minutes to pass along some information in reply to many of the letters that cross my desk from month to month. This may save some of you a bit of time, and, for others, get you into the action.

We publish an activities calendar in each issue of *Horizons* — usually toward the back of the magazine. We try to keep it as current as possible, and filled with operating activities and flea-market/hamfest events, etc. Hardly a month goes by without someone sending an announcement too late for the calendar. Some are quietly disappointed when their club doings are not in the calendar, and others become quite upset, with the result that another letter soon arrives, taking us to task for the omission.

I can see where some of the problem comes from, having served in various official capacities in assorted clubs in the past. The average club secretary is acquainted with the time-lag involved in assembling and printing (on an office duplicating machine of some sort) the club bulletin. The time from when the material leaves the typewriter until it is in the mail is usually no more than a couple of days or so, and it's usually no strain to get a newsletter out in plenty of time between club meetings. Naturally enough, the assumption is that allowing an extra month will be sufficient to get an announcement into a magazine. So, in late March, we receive announcements of things to be put in the May issue of *Horizons*. No way! Each issue goes in the mail during the first week of the month preceding its cover date — the May *Horizons* is mailed from the printer somewhere around April 1.

How do you beat the system? Back your dates up two or three months — for the July issue, announcements should arrive here before May 10th, for example. I'll not go into detail as to why this much lead time is required, except to say that there are a lot of steps required between a typewritten letter and the final announcement in printed form, bound into a magazine and ready for mailing. It's an inescapable part of the publishing business. So, a rule of thumb — work backwards two months from the month of your activity, and send your letter to arrive here the first week or so of whatever month that turns out to be.

Of course, we're beginning to feel a space crunch in the calendar, especially in the spring and fall months, but that's our problem . . .

Another subject: I've received many letters from people who like the new look of *Horizons*, and offering suggestions about further improvements, articles they would like to see, and so on. Several have asked how to write an article for us.

It's not hard at all. Just sit down at your typewriter and start writing, double-spaced, with margins of 1½ inches all around . . . or, better yet, send me an addressed, stamped envelope (business size), and ask for an author's guideline. It gives you all the information, plus ideas about subjects, preparation, payment (yes, \$\$\$), and requirements for both *Ham Radio Horizons* and *ham radio* magazine. It'll also tell you about drawings and photographs that are needed with the article.

If you would like a little preview of how it's done, before you send that letter, dig out the December, 1978 issue of *Horizons*, and look up "Write That Article," by W6NIF.

While you're thinking about getting into the act, how about photographs? Good black and white shots are essential to most articles, of course, but a really good color shot suitable for use on the cover is very hard to come by. The requirements are tough, but the money that's paid for a good one will buy a lot of film (or beer, or tickets to a ball game, or . . .). Then, too, there's nothing like having your very own "framed" cover shot on your shack wall; your entry into the world of photography.

What do we need? What do we like? Best thing to do is take a look at past issues and see what is on the covers for various months. The cover shot doesn't have to relate to the lead story (but it is nice if it works out that way). The photos should be seasonal (no July flea-market shots on a January magazine, etc.), and people are an essential ingredient — as essential as the direct tie-in to Amateur Radio. Transparencies, prints, negatives, and slides are acceptable, in that order. If this really turns you (and your camera) on, again, an addressed, stamped envelope will bring you more details. Let's make *Horizons* your magazine!

Tom

Thomas McMullen, W1SL
Managing Editor

UNSURPASSED RTTY

No other RTTY terminal made gives you ALL the features of our new DS3100 ASR:



- TX/RX operation with 3 codes: Baudot RTTY, Morse Code, ASCII RTTY
- Storage buffers for 150 lines of RX storage and 50 lines of TX storage
- The HAL "original" split screen shows both RX and TX buffers or whole screen for RX
- Ten programmable "Here Is" messages can be chained from one to next
- The EAROM allows power-off storage of 2 "Here Is" messages and terminal operating conditions
- Programmable WRU answer-back and selective-call features
- Separate CW identification key for RTTY operations
- Automatic TX/RX control with KOS plus 4 keyboard controlled accessory switches
- Internal real time clock keeps 24 hour time plus date
- Newly developed CW receive circuitry and programs give superior CW reception
- New green, P31 phosphor display screen gives clear, eye-easing viewing
- On-screen status indicators give continuous display of terminal operating conditions
- Word-Wrap-Around prevents splitting of words at end of display line
- Continuous, line, and word modes offer flexibility in editing transmit text
- Attractive streamlined metal cabinet gives effective RFI shielding from transmitters

Here Are More DS3100 ASR Specifications that Give You State-of-the-Art RTTY Operation:

QBF and RY test messages ■ Loop and RS 232 RTTY I/O ■ Plus or minus CW key output ■ 25 pin EIA modem connector ■ Half or full duplex ■ Upper-lower case ASCII ■ All ASCII control codes ■ Optional line printer for all codes ■ Selectable ASCII parity ■ 110 to 9600 baud ASCII ■ 45 to 100 baud Baudot ■ 1 to 175 WPM Morse receive and transmit ■ UnShift on space for Baudot ■ SYNC idle for RTTY and Morse ■ Break key for RTTY ■ Tune key for Morse ■ Automatic CR-LF ■ 120/240 v, 50/60 Hz power ■ Custom labeled key tops show control operation ■ Copy receive text into transmit buffer ■ TX flags allow segmenting of TX buffer ■ One year warranty ■ Price \$1995.00



HAL COMMUNICATIONS CORP.
 Box 365
 Urbana, Illinois 61801
 217-367-7373

For our European customers, contact: Richter & Co. D3000
 Hannover 1 • I. E. C. Interelco, 6816 Bissone/Lugano • Radio
 Shack Ltd., London NW6 3AY • Erik Torpdahl Telecom, DK3660
 Stenløse Denmark

**HAL Communications and
 amateur radio serving
 the 1980 Winter Olympics
 through W.O.R.A.N.
 (Winter Olympics Radio
 Amateur Network)**

WILSON SYSTEMS TOWERS

- IN STOCK -

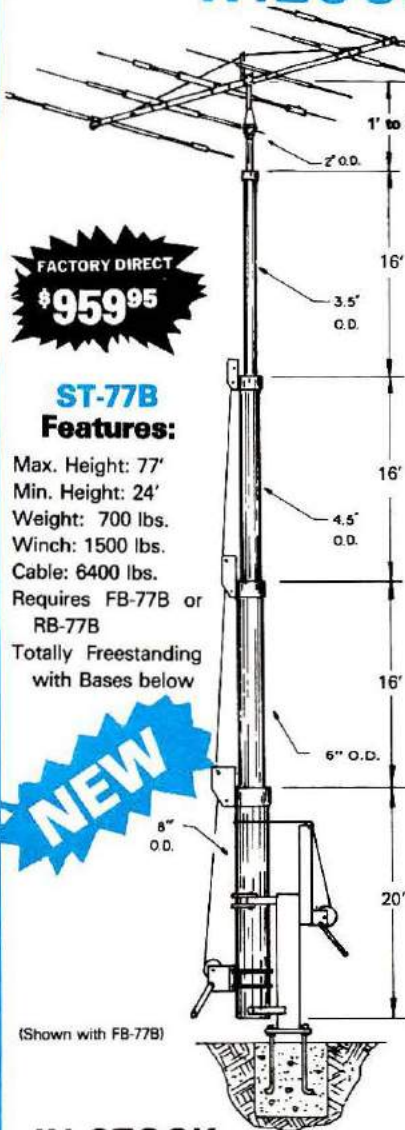

FACTORY DIRECT
\$959⁹⁵

ST-77B
Features:

Max. Height: 77'
Min. Height: 24'
Weight: 700 lbs.
Winch: 1500 lbs.
Cable: 6400 lbs.
Requires FB-77B or RB-77B
Totally Freestanding with Bases below

FACTORY DIRECT
\$554⁹⁵

MT-61B
Features:

Max. Height: 61'
Min. Height: 23'
Weight: 450 lbs.
Winch: 1200 lbs.
Cable: 4200 lbs.
No Guys required when mounting against house.
For completely freestanding installation, use RB-61B or FB-61B below.

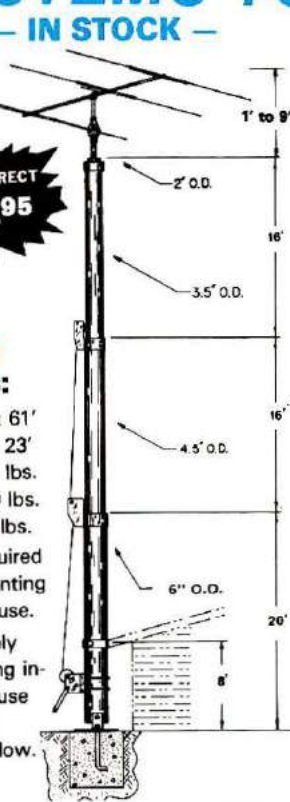

FACTORY DIRECT
\$319⁹⁵

TT-45B
Features:

Max Height: 45'
Min. Height: 22'
Weight: 250 lbs.
Winch: 1200 lbs.
Cable: 4200 lbs.
No Guys required when mounting against eve of house.
For completely freestanding installation, use RG-45B or FB-45B below.

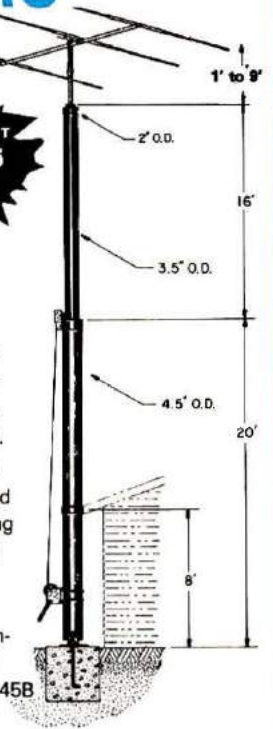

WIND LOADING			
Tower	Height	Sq. Ft.	Square Footage Based on 50 MPH Wind
ST-77B	69	18	
	77	12	
MT-61B	53	18	
	61	12	
TT-45B	37	18	
	45	12	

BASE CHART		
TOWER	WIDTH	DEPTH
TT-45B	12" x 12"	30"
FB-45B	30" x 30"	4 1/2'
RB-45B	30" x 30"	4 1/2'
MT-61B	18" x 18"	4'
FB-61B	3' x 3'	5 1/2'
RB-61B	3' x 3'	5 1/2'
ST-77B	See Below	Bases
FB-77B	3 1/2" x 3 1/2"	6'
RB-77B	3 1/2" x 3 1/2"	6'

IN STOCK

All three towers above are able to handle large arrays of up to 20 sq. ft. at 80 mph WHEN GUYED with one set of 4-point Guys at the top of the 3 1/2" section. Guying Kits are available at the following prices: GK-45B—\$59.95; GK-61B—\$79.95; GK-77B—\$99.95. When using the Guy System with RB Series Rotating Base, an additional thrust bearing at the top is required. The WTB-1 is available for \$49.95.

Wilson Systems uses a new high strength carbon steel tube manufactured especially for Wilson Systems. It is 25% stronger than conventional pipe or tubing. The tubing size used is: 2" & 3 1/2"-.095; 4 1/2" & 6"-.125, 8"-.134. All tubing is hot dip galvanized. Top section is 2" O.D. for proper rotor and antenna mounting.

The TT-45B and MT-61B come complete with house bracket and hinged base plate for against-house mounting. For totally freestanding installation, use either of the tilt-over bases shown below.

The ST-77B can not be mounted against the house and must be used with the tilt-over base FB-77B or RB-77B shown below.

TILT-OVER BASES FOR TOWERS

FIXED BASE

The FB Series was designed to provide an economical method of moving the tower away from the house. It will support the tower in a completely free-standing vertical position, while also having the capabilities of tilting the tower over to provide an easy access to the antenna. The rotor mounts at the top of the tower in the conventional manner, and will not rotate the complete tower.

- FB-45B .. 112 lbs... \$159.95
- FB-61B .. 169 lbs... 219.95
- FB-77B .. 250 lbs... 304.95

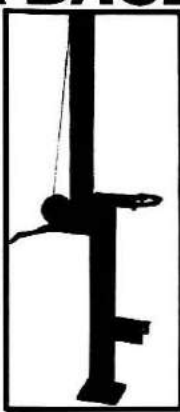

ROTATING BASE

The RB Series was designed for the Amateur who wants the added convenience of being able to work on the rotor from the ground position. This series of bases will give that ease plus rotate the complete tower and antenna system by the use of a heavy duty thrust bearing at the base of the tower mounting position, while still being able to tilt the tower over when desiring to make changes on the antenna system.

- RB-45B .. 144 lbs... \$224.95
- RB-61B .. 229 lbs... 304.95
- RB-77B .. 300 lbs... 454.95



Tilting the tower over is a one-man task with the Wilson bases. (Shown above is the RB-61B. Rotor is not included.)

ORDER
FACTORY DIRECT
1-800-634-6898

W S I WILSON
SYSTEMS, INC.
4286 S. Polaris Ave., Las Vegas, Nevada 89103

NEWSLINE

FCC'S 10-METER-LINEAR BAN was upheld in a unanimous decision by the U.S. Circuit Court of Appeals in Washington last February. The ARRL had characterized the ban as "senseless administrative overkill" in its suit, but the three-judge panel agreed unanimously that the Commission had not abused its administrative powers in deciding on the ban as a means of limiting CB misuse of linears, which had triggered rapid growth of TVI complaints.

The League's Objection to the ban was not without merit, the court noted. Judge Edward A. Tamm wrote in the decision: "Had we been the rule makers in the case, we might have been more hesitant in encroaching on the domain of the innocent Amateur Radio operators." Traditionally, it has been unusual for a court to overturn an administrative agency's ruling, except in cases where the agency has been shown to have "abused the broad policy-making discretion granted it by Congress" and to have "acted beyond the scope of its rule-making authority."

EXISTING CLUB, RACES, and Military Recreation Amateur licenses should probably be retained, the Commissioners agreed at the March 12 Agenda meeting, but no new licenses of these classes should be issued in the future. During their deliberations, the Commissioners weighed the alternatives of dropping the freeze on these licenses and accepting applications for new ones (too expensive), as well as doing away with them altogether. With only 611 RACES, 331 Military Recreation, and about 2000 Club licenses currently in force, annual cost to the FCC was estimated at only \$1600 — not unreasonable for the benefits of continuing them.

Holders Of Current RACES, Club, and Military Recreation licenses will be able to now modify as well as renew them when and if required. However, it's likely that there'll be provisions for a fee on Club license processing in the Report and Order the Commission staff will be preparing.

AMATEURS MUST STILL SEND the other station's call when ending a contact, despite an item in a recent DX newsletter that notices of such violations during the recent ARRL CW DX contest were being held pending new rule making. Though proposals to relax the requirement have been made, they are opposed by the Field Bureau. It would be very irregular for "pink tickets" to be held back awaiting a possible future rules change.

AMATEUR RADIO'S NEW 10-MHZ BAND should be limited to CW only, the IARU Region 1 Executive Committee agreed at its London meeting in February, to provide maximum utilization of the shared 50-kHz allocation when it becomes available January 1, 1982. No action is likely by Region 1 Amateur organizations until April, 1981, however, when the next Region 1 Triennial meeting is scheduled.

Strong Support for an all-CW "30-meter" band has also been registered by U.S. Amateurs who have written ARRL headquarters on the subject, with only a small minority advocating setting aside sub-bands for other modes. A few have also suggested it have a lower power limit, a desirable idea since lower power would tend to reduce interference with the other services sharing the band.

ARRL's Ad-Hoc 10-MHz Committee had its first meeting in Gaithersburg on March 8, but, despite plenty of discussion agreed not to reach any conclusions until it had much more input from League members and Amateurs at large. The committee plans to make its recommendations to the directors at their July meeting and will be meeting again in May. Ideas and suggestions are urgently solicited and should be submitted care of W4WHN.

AMSAT'S PHASE III-A SATELLITE will be flying earlier than planned. Latest word is that the launch date for Phase III has been moved back to May 20th from May 30th.

Acceptance Tests on the Phase III transponder were successful and the unit has been approved and licensed by the Deutsche Bundespost.

The Phase III-A Spacecraft was shipped to Frankfurt on February 19 and then brought by a special trailer to Toulouse, France, for vibration tests (February 27) and final acceptance of the satellite flight plans. W3GEY, K1JX, DJ4ZC, and other members of AMSAT/Deutschland went to Toulouse to monitor the testing.

Solar Cell Sponsorship now totals 4414 solar cells and 43 battery cells.

EMERGENCY AND PRIORITY MEDICAL TRAFFIC from any maritime or land-based station can now be routed through the Cleveland, Ohio, office of the U.S. Public Health Service. WB2QET/8 monitors 28.911 MHz for the first five minutes of each hour between 1300 and 2100Z. The station, which was set up under the direction of Dr. Steven H. Posner, WB2QET, offers phonepatch access to any medical facility in the country.

A weekend project that you'll be proud to use and display.

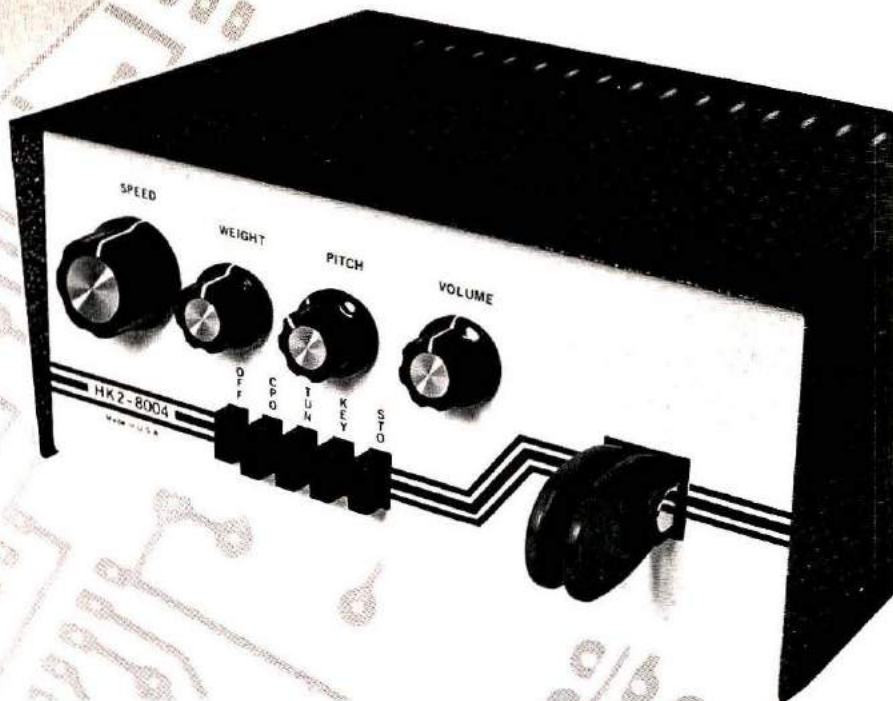

Printed-circuit techniques and modern integrated-circuit technology are combined in this weekend project that is very easy to build and will yield many years of operating pleasure. The project can be completed in a single weekend, and no special tools or equipment is required. No alignment or adjustments are needed, other than those required to make the keyer comfortable for you to use. Results are ensured through the use of a printed-circuit board that is available if you do not have the facilities for etching your own. The keyer is self-contained, and is battery powered for portable operation. Additionally, the keyer features a very high degree of isolation between the transmitter keying circuit and the paddle assembly for operator safety. The project is easy enough for the first time builder and the results are such that even an old-timer would be proud to proclaim the fact that the unit is homebrew. Spend a weekend building and then enjoy many weekends of CW with your own electronic keyer!

BY KEN POWELL, WB6AFT

An-Easy-to-Build Keyer

What it is

This easily constructed keyer is built around two major components: the popular 8044 integrated circuit and the HK-2 paddle assembly.

These two main components, and a handful of common electronic parts, combine to furnish all the features usually associated with a modern electronic keyer. It provides self-completing dots, dashes, and spaces. The circuit allows squeeze-key operation, and the PC-board-mounted paddle assembly is fully adjustable. The paddles are placed in a comfortable position to the right of the operator controls. The isolated keyer output can be used with positive or negative keying voltages, and the unit displays a high degree of immunity to strong rf fields. Battery power adds to the safety and portability of the unit, and low power consumption ensures long battery life.

The controls

A full complement of controls are furnished on the front panel for operator convenience. These controls are speed, weight, pitch, and volume. Keyer speed is variable from approximately 5 to 50 WPM, and the weight control enables you to tailor the dot-dash relationship to your individual taste or style. The pitch and volume controls allow you to set the output from the internal speaker to a frequency and level that is comfortable. A five-position, interlocking push-button switch assembly provides the remainder of control functions. This PC-board-mounted switch unit provides smooth, push-button control of the keyer functions, and adds to the ease with which the project can be completed. Position 1 (OFF) of the switch assembly provides power control. Pushing this button releases any other button that had previously been activated and removes power from the keyer. Activation of any other function button will release button 1 and apply power to the keyer. Depressing button 2 (CPO) will apply power in the above manner and will place the keyer in a code-practice-oscillator mode. This mode will allow the keyer to function and the side

tone to be generated, but the keying circuit to the transmitter will remain inactive. This is great for a little warm-up session prior to going on the air! Push button number 3 (TUN) is a tune-up position which will key the transmitter and will provide a side tone as a reminder that you are in a key-down mode. Button number 4 (KEY) places the keyer in operation but defeats the internal side-tone signal, allowing use of the side-tone facilities in your own rig, if it is so equipped. Button number 5 (STO) places the keyer in operation and allows use of the internal side tone and speaker. These switches and controls provide complete control of the keyer functions from the front panel and eliminate behind-the-unit fumbling so often associated with today's compact equipment. The cabinet chosen for the keyer provides easy access for paddle adjustment and battery service, and the rubber feet provided make the keyer stable enough to prevent walking as the paddles are activated. A slightly larger knob was chosen for the speed control to make it easy to find in the middle of a big Saturday morning pile-up.

Circuit

After reading the description of the electronic keyer it would seem to require a great deal of circuitry to accomplish the many functions described. However, a check of the schematic diagram shown in Fig. 1 will reveal that this is not the case. With today's technology, one integrated circuit can provide the performance of several hundred transistors, and this is just what is accomplished with the Curtis 8044 integrated circuit. This IC, and the HK-2 paddle assembly, form the basis

for the easily constructed keyer.

The 8044 accepts the contact closures from the key and generates perfectly formed dots, dashes, and spaces. The contact de-bounce, dot and dash memories, and iambic features are all contained in the IC. Keying speed is controlled by R9 while weight is controlled by R11. The side-tone signal is also generated by the IC and the audio pitch is controlled by R10. The range provided by the panel-mounted controls is more than adequate for most applications. The keyed output of the 8044 IC is applied to a general purpose NPN transistor, a 2N2222 in our example. The collector load for this transistor is the light-emitting-diode section of the optical coupler, U2. When the keyer is activated by the dot or dash paddle, a high level is presented at pin 14 of U1 and the transistor conducts, allowing current flow through the LED section of the optical coupler, U2. The light emitted by the LED provides base current for the transistor section of U2, and the conduction of the transistor keys the transmitter. A silicon diode is placed across the coupler transistor and acts as a short circuit in the event of incorrect polarity being applied to the keyer output circuit. If you connect the transmitter keying circuit incorrectly, no damage will be incurred but the transmitter will be keyed continuously, indicating incorrect polarity at the keyer. The optical coupler provides a very high degree of electrical isolation between the keyer and the keyed circuit, and keeps relatively high keying voltages from being present at the paddle assembly. Keying voltages of 300 volts are easily handled by the optical coupler.

The side-tone signal is internally generated by U1, and the audio out-

more fun . . . less work . . .

It's like the first time on the air.

An Easy Keyer

put is available at pin 13. This signal is applied to another 2N2222 transistor, which is transformer coupled to the internal speaker. The audio output from the very small speaker is adequate for the ham shack, but a larger speaker would yield enough audio for classroom work if this was desired. A phone jack could be added to the back panel to make this 8-ohm audio line available to an external speaker while muting the internal unit.

The control-switch assembly mounts on the PC board, and eliminates a great deal of wiring while adding some control functions not normally found on keyers. The mechanical interlocking feature of this low-cost switch assembly lends itself well to this particular application. Switch S1 of this assembly removes power from the keyer by breaking the battery circuit. Activating any subsequent switch will release S1 and apply power to the keyer circuit. S2 disconnects the keyed output of U1, and allows the keyer to operate as a code-practice oscillator. This is accomplished without the bother of disconnecting the keyer from the transmitter. S3 is the tune switch position, which keys the transmitter via U1 while providing a side-tone signal as a reminder that the carrier is on. S4 mutes the local side-tone signal by keeping the audio transistor cut off (non-conducting), and allows use of the side tone in your transceiver. S5, while looking as if it does not do anything at all in the schematic diagram, actually powers the keyer via the mechanical interlock built into the switch assembly, and thus places the keyer in operation. In this position, the side-tone signal is available locally via the internal speaker.

Power consumption is low enough that the 9-volt battery will provide many hours of operation. This mode of power was selected to provide portable operation and to eliminate another power cord in the shack. If ac-line operation is desired, a plug-mounted power supply, like the ones furnished with many games and port-

able radios, would be more than adequate. A small regulator should be added to hold the voltage constant. This could consist of a Zener diode or a three-terminal regulator. Like the battery supply, this type of power supply is very safe because 117 Vac is not brought into the cabinet or PC board area. Solid-state circuitry has made us all a bit careless due to the low voltages normally encountered.

Construction

Although any type of construction

ature components. This spacious layout should help to make construction easy. Prior to actually starting construction, it is a good idea to get all the parts together, study the schematic diagram a bit, look over the foil and parts layout, and familiarize yourself with the "C" numbers, "R" numbers, and such. Although the component count in this project is low, it only takes one diode installed backwards to ruin a perfect weekend. So, go over the paperwork a bit and lay all the parts out on the bench for easy

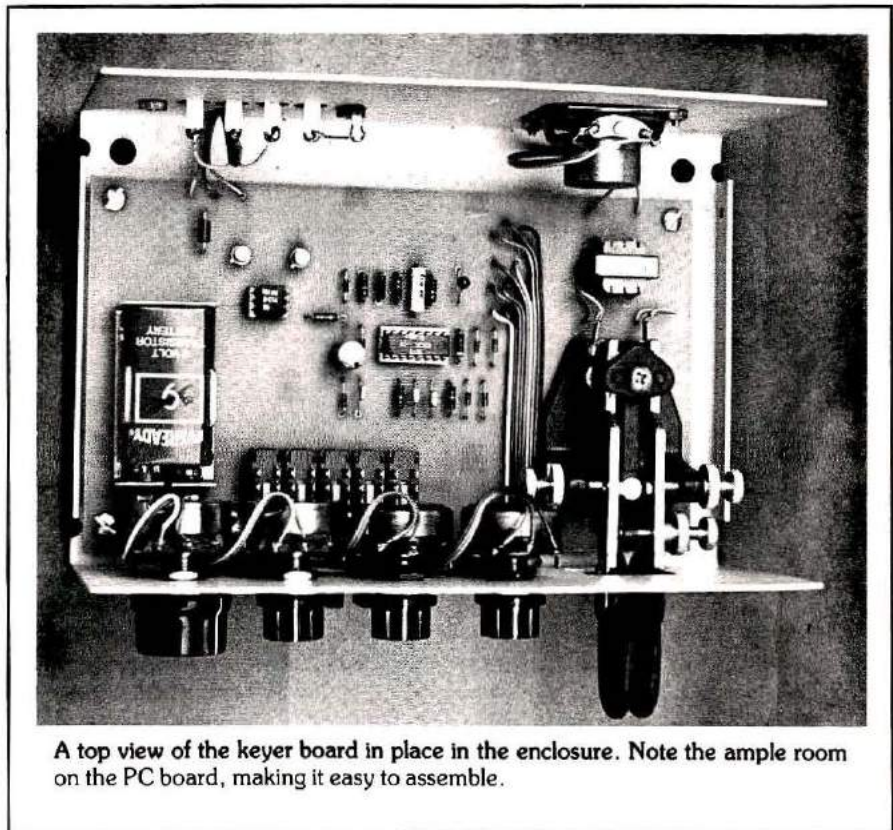

could be used for the keyer, printed-circuit board construction was chosen both for ease and repeatability. PC board construction allows a project of this type to be accomplished in just a few hours, and most of the tedious wiring is eliminated. The use of board-mounted switches also speeds construction. I have found that many Amateurs have a very difficult time relating switch contacts on a schematic diagram to the actual hardware. In this case, it is no more complex than snapping the switch into the holes on the PC board, and soldering the switch solder lugs to the land patterns or pads. The PC layout is not dense because I, like many other Amateurs, have a rough time working with mini-

identification, and get off to a good start.

The first step in construction is the etching and drilling of the PC board according to the foil layout depicted in Fig. 2. After drilling the board, mount the four spacers (that will support the board in the cabinet) upside down on the four corners of the board. This will protect the small components as the board is flipped over for soldering. The next step is mounting and soldering the board-mounted components, such as the resistors, capacitors, diodes, DIP socket for U1, and the optical coupler, U2. Pay particular attention to the diode polarity as you install each of the 1N914s.

The switch assembly can now be

mounted and soldered in place, going a bit easy on the solder to prevent excess flux from getting into the switch. The output transformer has a 1000-ohm center-tapped primary, only half of which is used, so you should be connecting the center wire and one outside wire to the board and have one outside wire left over, which can be cut close to the transformer coil. The paddle assembly should be stripped down, and the base-mounting stud will have to be cut short enough to clear the bottom of the cabinet; one-half inch should do it. The paddle-assembly base can now be mounted to the PC board. Taking the keyer paddles off the base allows using a much smaller hole in the front panel. The paddles will be installed through the front panel after you have mounted the PC board.

After all the components are mounted on the PC board, the wiring that will connect to the controls and other cabinet-mounted parts can be soldered to the board. Stranded wire should be used for this purpose, and the battery holder and paddle solder lugs can be wired with stranded wire

at this time. Leave a bit of slack in the wiring for these two components, as it is necessary for these wires to flex during normal operations. Color-coded, or ribbon, cable is a good choice for this type of assembly because the wires can be laid in place and spot-tied prior to installing the PC board in the cabinet. Refer to the photograph of the unit with the PC board installed to get an idea of the wire

routing. Leave all the interconnect wiring longer than necessary and trim it to the proper length when the final wiring is done inside the cabinet. In this manner, you can get a very neat, commercial look on the interconnections. The spacers can now be transposed, and you should have a neat looking board ready for installation.

The cabinet can now be drilled for the controls, switches, speaker, termi-

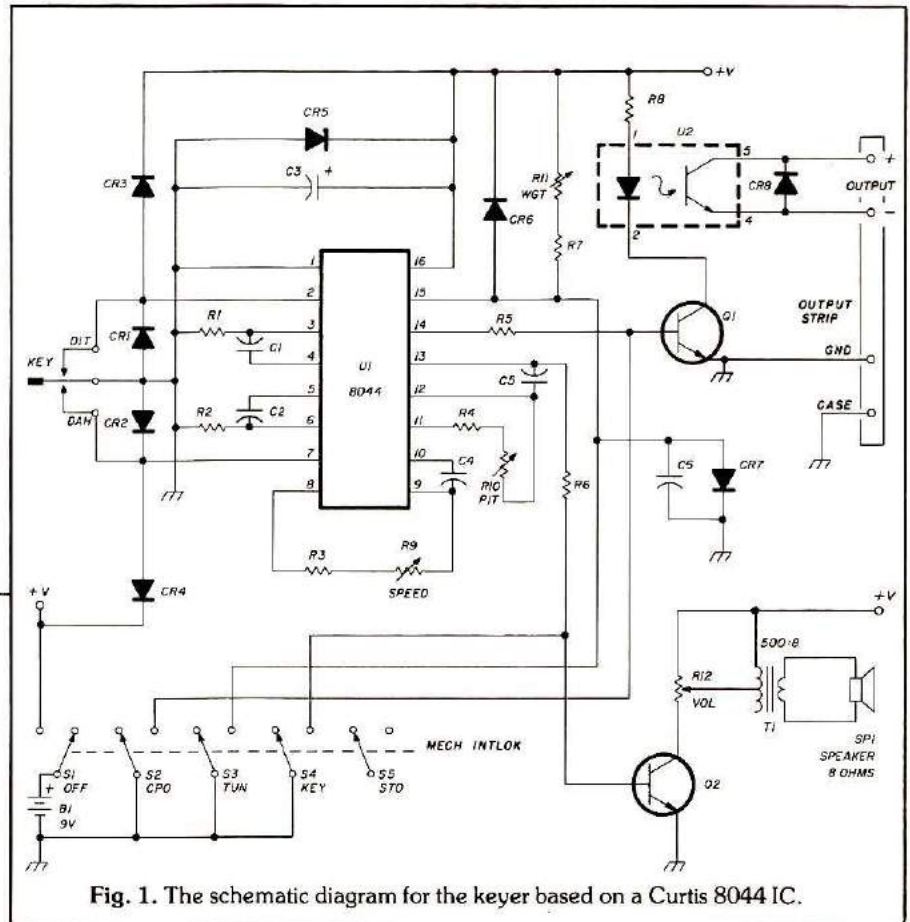

Fig. 1. The schematic diagram for the keyer based on a Curtis 8044 IC.

Table 1. List of parts for the WB6AFT keyer.

C1,C2	0.1 μ F/16 V
C3	22 μ F/16 V
C4	0.15 μ F/16 V
C5	0.01 μ F/16 V
C6	0.22 μ F/16 V
CR1-CR7	1N914 diode
CR8	1N4006 diode
Q1,Q2	2N2222
R1,R2,R3	100 K 1/4W
R4,R6,R7	10 K 1/4W
R5	1 K 1/4W
R8	330 1/4W
R9,R10,R11	500 K pot, linear taper
R12	1 K pot, linear taper
T1	1 K c.t. primary; 8 ohm secondary, RS 273-1380
U1	IC, Curtis 8044
U2	Optical coupler, GE H11D1

Battery	9 V transistor	Eveready 1604
Battery Holder	Keystone 203-P	BA 12A2351-1
Cabinet	3-1/2 x 7-7/8 x 5-11/16	RS 270-269
Key	Ham-Key HK-2	
Knob	1 inch diameter	RS 274-416
Knobs	3/4 inch diameter	RS 274-415
Spacers	1/2 inch length	RS 64-3024
Speaker	1-1/2 inch PM	BA 34A410-1
Switch Assembly	5 position push-button	BA 18A1731-9
Terminal Strip	4 position	RS 274-665

RS: Radio Shack, local stores

BA: Burstein-Applebee, 3199 Mercier St., Kansas City, Missouri 64111

Curtis: Curtis Electro Devices, Box 4090, Mountain View, California 94040

The Ham Key Co., P.O. Box 28271, St. Louis, Missouri 63132. See page 67, this issue.

PC boards, parts, and complete kits are available from: J. Oswald, 1436 Gerhardt Ave., San Jose, California 95125.

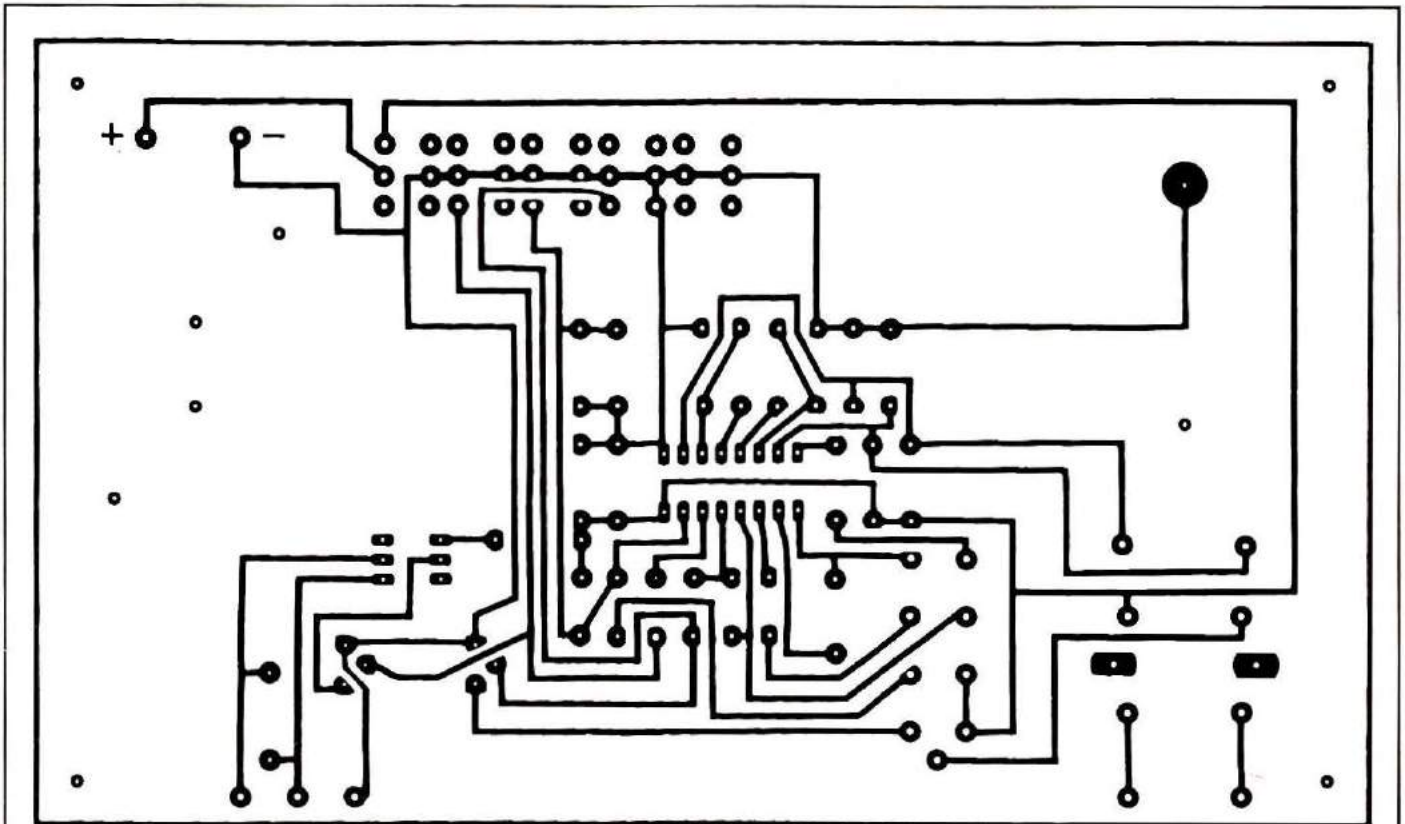

Fig. 2. Full-size PC board layout, from the foil side.

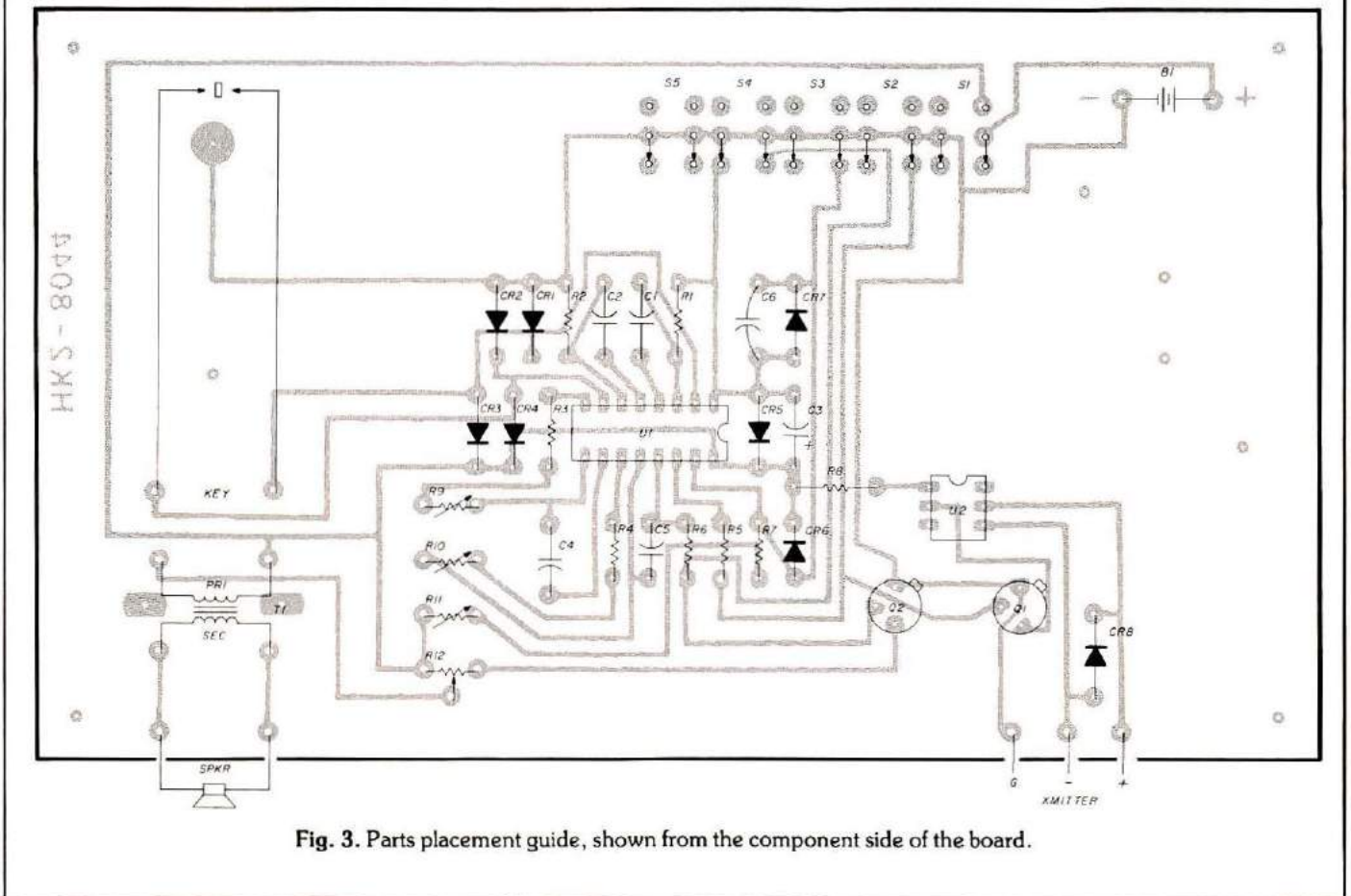

Fig. 3. Parts placement guide, shown from the component side of the board.

nal strip, and mounting spacers. Since the cabinet base is furnished unpainted, it can tolerate a bit more rough handling than many of the bases I have tried to work with in the past. After completing the sheet-metal work, I lightly sanded the cabinet base, and applied a couple of coats of spray paint. Rub-on lettering completed the cabinet, and gave it a professional look.

The cabinet-mounted components can now be put in place, and the PC board installed in the cabinet. The interconnect wiring to the controls, speaker, and connectors can now be cut to length and soldered to the appropriate terminals. The keyer paddles can be slipped through the front panel, and the paddle assembly restored to normal. The two small solder lugs can now be mounted to the ends of the paddles. The handles on the paddles can be reversed if you like the wide-spaced arrangement, but this must be done prior to slipping the paddles through the front panel and reassembling the keyer.

This completes the wiring and mounting, and the front panel knobs can be installed. Carefully install U1 and the battery, and you are ready to forget that old straight key until SK night!

Testing

With the CPO switch (S2) depressed, the keyer can be checked and the paddles adjusted for a comfortable feel. Closing the dit-paddle contacts should produce continuous dits. The dah paddle should yield the same results but with dahs about three times the length of the dits. Changing rapidly from dits to dahs will use the dit and dah memories as well as the spacing. Squeeze keying that is initiated with the dit paddle will produce a string of alternating dits and dahs. Conversely, squeeze keying initiated with the dah side will produce a string of dah-dits. You're right, it will take a little practice to fully use all the benefits of this new keyer!

The speed control should vary the speed from a very slow rate to a string of dits that sound like RTTY as the control is advanced in a clockwise direction. The weight control will vary the relationship between the dits and dahs but is not profound in its action. The pitch control will produce a very

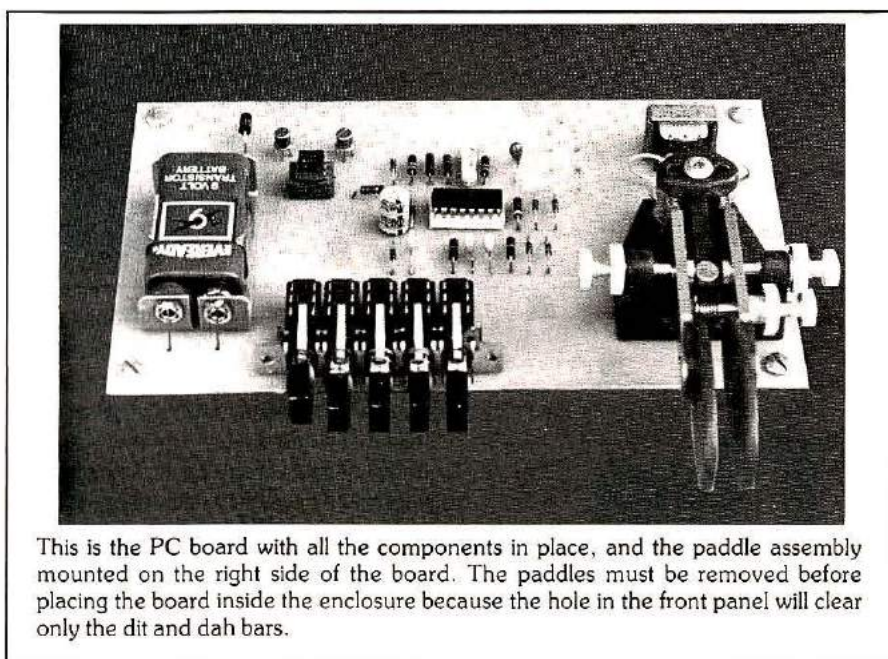

This is the PC board with all the components in place, and the paddle assembly mounted on the right side of the board. The paddles must be removed before placing the board inside the enclosure because the hole in the front panel will clear only the dit and dah bars.

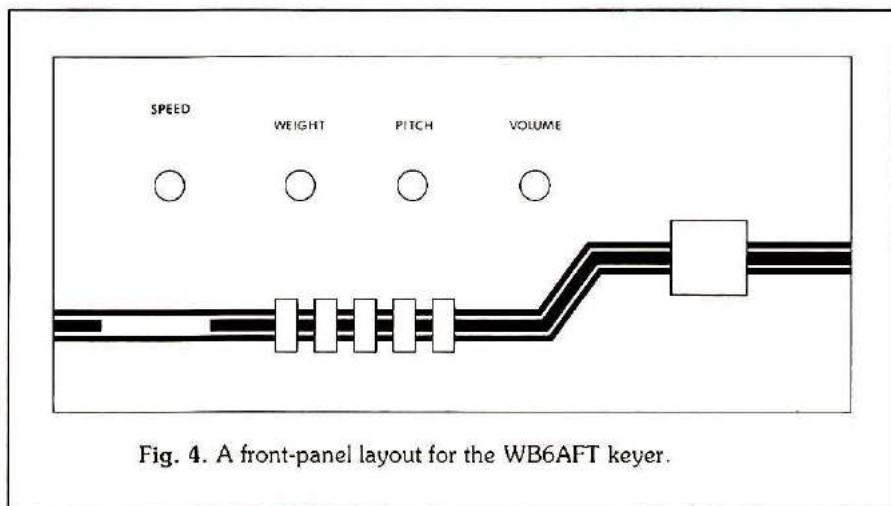

Fig. 4. A front-panel layout for the WB6AFT keyer.

broad range of tones well up into the audio spectrum as it is advanced. The volume control will vary the audio output from zero to a point where it overdrives the little speaker. If the control wiring is correct, all the controls will increase their respective functions when the pots are rotated in a clockwise direction.

If all the preceding checked out well, the unit can be connected to the transmitter, observing the polarity noted on the connector strip. If the keying line polarity is reversed, the transmitter will be keyed without power applied to the keyer. After assuring yourself that this is not the case, check out the tune, key, and side-tone positions as described earlier. Practice on the keyer for a

while and be sure that you are comfortable with the paddle adjustments prior to closing the case and jumping into that pile-up on 20 meters.

Conclusion

There is not too much to say about the keyer that I haven't already covered, but I would like to say that it was a very rewarding weekend project. It is a piece of equipment that you can use every time you get on the air (in a CW mode anyway), and it has made CW a lot more fun and less work for me. It's like the first time on the air again. This little project that was actually completed in a single weekend turned out to be the nicest weekend I have had in quite a while!

HRH



The Fourth Time's the Charm

WAYNE OVERBECK,
N6NB

A Transcontinental
VHF Odyssey

Radio Amateurs go all over the world on DXpeditions to put ham radio stations on the air in unusual and exotic places. No matter what it costs or how much trouble it is, sooner or later a ham will get on the air in any country where it's possible to get a license.

You'll find hams spending thousands of dollars to charter a boat and visit uninhabited coral reefs in the South Pacific — tiny islands that aren't even on the map except as hazards to navigation. You'll hear hams on the air in distant lands that may be engulfed in civil unrest, working other hams on 20 meters while there's gunfire in the distance.

This is not a story about that sort of DXpedition, but the odyssey described here would seem just as crazy to anyone who doesn't have a callsign after his name. You see, my specialty in Amateur Radio is the vhf bands. I prefer frequencies like 2 meters, where anything farther away than a few hundred miles is rare DX indeed, even with high-power SSB equipment.

On a vhf band such as 2 meters, a station in Utah that can be heard in California will cause just as much excitement as a station 10,000 miles away will on 20 meters. If you're operating on the vhf bands, you don't have to go to some faraway land for your trip to be a DXpedition. But that doesn't necessarily mean a vhf DXpedition is easy (or cheap). This one certainly wasn't.

For years, I had been operating in the vhf contests, which occur several times a year, using mountaintops near my southern California home as my site. Now, a trip to a nearby mountaintop could be called a DXpedition of sorts; you can certainly work more DX on the vhf bands from a mountaintop than from the places where most of us live. But, in contest after contest, I kept noticing that the spectacular scores were coming from an area some vhf'ers call the "golden corridor." This corridor runs from

Boston to Washington, D.C., and is sort of a heaven for vhf enthusiasts.

Why is that so? Well, suppose your normal range is about 300 miles on the 2-meter band. Draw a 300-mile circle around New York City or Philadelphia and calculate how many million people and how many different states fall within that radius. Now draw a similar circle around any point in the U.S. that's not along the "golden corridor" and you'll see why most of the winning scores in vhf contests over the years have been achieved by stations somewhere along the corridor.

As a Californian whose interest in vhf contests borders on fanaticism, I was envious. I dreamed of having one day a big vhf station, complete with kilowatt transmitters and big antennas, atop a mountain somewhere near the corridor. I'd operated thirty different vhf contests from the dry and barren mountaintops of the West by this time, and I knew the grass was greener in the East, both literally and figuratively. I'd even won a few vhf contests from California, but that only happened because of either unusual propagation or the fact that no one was really trying very hard "back East." All of the real winners were along the corridor, and I just had to go there.

Expedition No. 1

Dreams soon turned into plans, and I had airline tickets to Boston for the weekend of the September, 1978, vhf contest. A rental car (unlimited mileage, of course) awaited me at Logan Airport, and my friend Tom McMullen, W1SL, who lives in New Hampshire, had generously offered to provide his pickup truck and to help with what would be a massive logistics problem. The ultimate destination would be Mt. Equinox, Vermont, one of the best mountaintops within vhf range of the "golden corridor."

I knew I had a lot of radio equip-

ment, but I never really understood just how much until I started packing for the flight. I'd bought four large trunks, but they quickly filled up and I still needed more room. I ended up with three more large suitcases crammed full, for a total of nearly 1,000 pounds and seven pieces of luggage.

You can guess what the airline people had to say when they saw the luggage, and especially when they tried to lift the trunks. Suffice to say there was a slight overcharge for excess baggage.

Safely in Boston, I waited eagerly as the luggage came down the chute. One, two, three, four, five, six . . . Whoops, I started with seven pieces. The missing one had all the interconnecting cables and relays in it; nothing in the other six suitcases would work!

"No problem," said the airline people. "It happens all the time. We'll deliver your missing luggage when we find it. What hotel are you staying in?"

Try telling an airline you'll be camped out on a mountain in Vermont and that they'll have to deliver the luggage there. Just try.

Even worse, try telling them you simply must have that suitcase because you're operating a vhf radio contest and the whole trip will be a flop without the equipment in the missing suitcase.

Blank looks of indifference.

"Look, suppose Jack Nicklaus flew here for a golf tournament and you lost his golf clubs," I said, desperately trying an analogy.

"Well, he'd have to borrow someone else's."

After hours of haggling, I finally got the airline officials to agree to airfreight the crucial suitcase to an airport near Tom's house in New Hampshire.

I drove off, one suitcase short.

Amazingly, the missing suitcase did arrive in New Hampshire that night, but the delay put us hopelessly behind schedule; the contest would begin at 3:00 the next afternoon, and there were a jillion details yet to arrange.

In an incredible rush, we bought out a Radio Shack store's stock of masts and antenna parts, rented a gasoline generator, bought Jerry cans, gathered lumber for a makeshift

operating console in the rentacar, and headed for Mt. Equinox, hours late. We reached the mountain just as the contest was beginning, only to find two other contest stations already set up there.

Ever try to operate a radio contest with two other stations transmitting on the same band 150 feet away? We all tried, but it took courtesy and patience; somehow we all emerged friends.

But first, Tom and I spent four hours of valuable contest operating time setting up antennas. Then Tom got settled into the inn atop Mt. Equi-

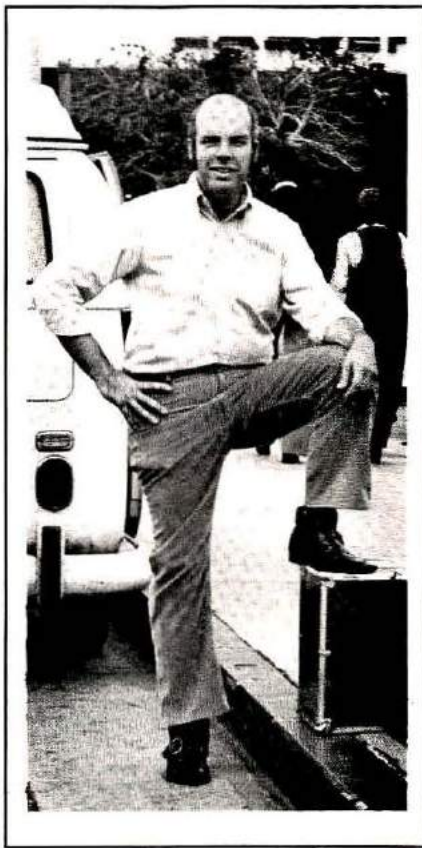

nox for the night, since the contest was to be a strictly single-operator effort for me.

For the next twenty-four hours, I roosted in the driver's seat of a rented Mercury Cougar surrounded by radio gear, some of it on the floor, some on the front and back seats, and some on the makeshift pine console which ran across the front and rear seat backs. The trusty rented generator was just outside, chugging away.

Inside, my teeth were chattering away. Frost quickly formed all over

the car's hood, indicating what the weather would be like all weekend — inside and outside the car. It wasn't exactly cozy, but with a clipboard on my lap I could operate and keep a log. And I'd finally realized my dream: I was atop a mountain near the "golden corridor" for a vhf contest — or for part of one at least.

The contest itself was truly exciting. The activity level in the Northeast is incredible, and I was so busy the contest passed in what seemed like no time.

On the airplane enroute home, I calculated my score: it was a new record for the September vhf contest, topping the old mark for single-operator stations by 12,000 points! However, my jubilation soon turned to depression when I learned K1FO, a prominent Connecticut vhf'er, had taken my Eastern visit as a personal challenge, and set out to teach this Western interloper a lesson. And he succeeded, breaking the old record by 13,000 points.

Back home in California, I thought the DXpedition over. Any sane person would say, "Gee, that was interesting," and get on with life. Me? I'd tasted vhfing in the big leagues. I knew I had to try again, but doing things right.

That meant I had to have a truck or van "back East," complete with a built-in generator (none of this pouring gas from Jerry cans in the dark and the freezing cold), and a comfortable operating console filled with gear that an airline couldn't lose! And, I needed bigger antennas.

I went to work that winter. I found an old but dependable one-ton Ford Supervan, and made it into a rolling radio station. When I was finished, it had electric heat (a must on New England mountaintops, as this Californian had learned the hard way), a reliable ac generator big enough to run everything at once, and a 30-foot crankup tower on the rear deck. There would be a second tower, too, this one a 70-foot crankup job on a trailer that the van would tow. The radio complement inside included kilowatt rigs for all bands from 3.5 through 432 MHz.

The second try

Now I was ready to do things right, or so I thought. Leaving a week be-

VHF ODYSSEY

fore the June, 1979, vhf contest, I would drive East, operate the contest, and leave the van and trailer with my friend Tom for future trips.

The motor trip was flawless. The ten-year-old van faithfully pulled the trailer three thousand miles in five days; I drove into Tom's huge yard in New Hampshire two days ahead of schedule.

By the Friday night before the contest, I was all set. I'd been assured by the management of Mt. Equinox that no other hams were planning to operate on the mountain this time, although there would be a sports car rally along the steep winding road to the summit. With all day Saturday still available to finish the setup job, the

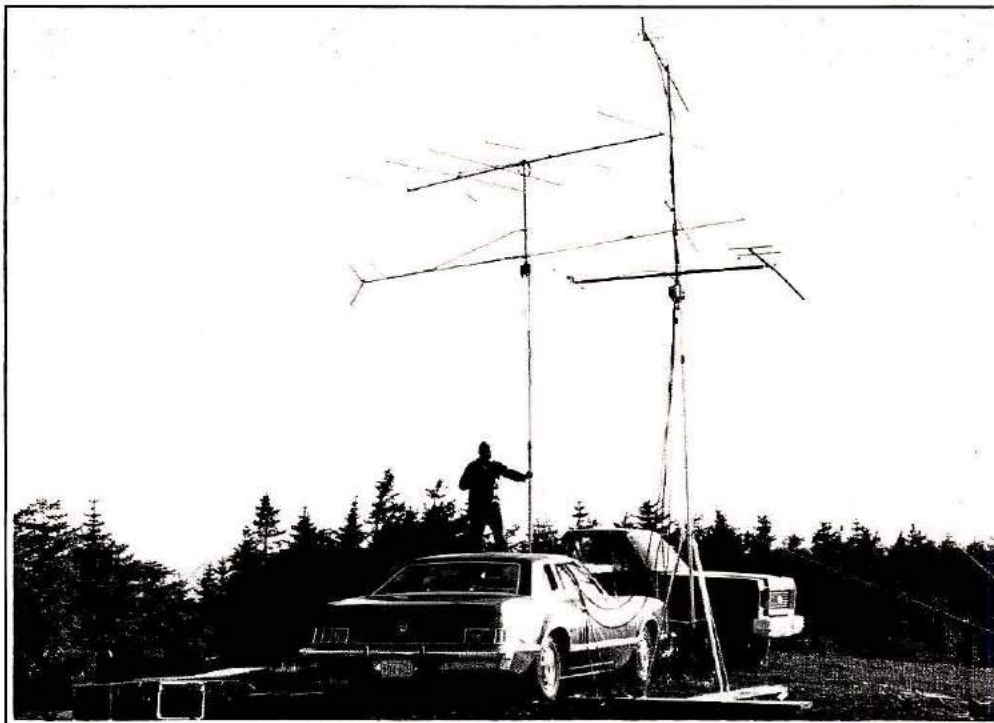

TRANS WORLD AIRLINES
EASTERN



van and the 70-foot tower were already in place. Ah, a good night's sleep before a contest!

It wasn't to be. Very early the next morning, there was an angry knock on the van door, and I looked through the curtains to see a big motor home with tower sections and a dish antenna on its roof. Whoops!

It seems a large multi-operator group had arranged with the sports car group to provide race communications, with assurances they could operate the contest undisturbed after-

ward. The people who manage the mountain itself, and the sports car people hadn't been communicating with each other.

I pleaded my case: I'd come all the way from California to operate the vhf contest on Mt. Equinox. But the hams who had made arrangements with the sports car club were adamant; they weren't going to share the mountain with anybody, no matter how amicable the sharing had been the last time I was there.

I talked the problem over with

Tom, who'd been quite long-suffering through all of this. He counseled calm and reason, suggesting we try to find another mountain, since we still had plenty of time to move.

Abandoning Mt. Equinox, we checked with some nearby vhfers, and they knew of this great place called Mt. Utsayantha in New York state. "You can be there in an hour, two at the most," we were told.

We drove all day. By 3 p.m., the contest was getting under way and we were nowhere near this "Mt. Utsayan-

Top: Here's W1SL with the antennas set up for Mt. Equinox, Vermont, expedition No. 1. It took nearly the whole inventory of a Radio Shack store to do this. *Below, left:* Skycap needed? Try boarding a plane with seven pieces of luggage, four of them trunks! Then pray all seven show up at the other end (they didn't). *Middle:* East Coast or bust. Armed with heavier artillery, N6NB heads east for another try at vhf contesting from Vermont. *Right:* He made it. After five days of driving, N6NB's vhf contest rig arrives in Vermont. Along the way, hundreds of truckers had gawked at this six-wheeler!

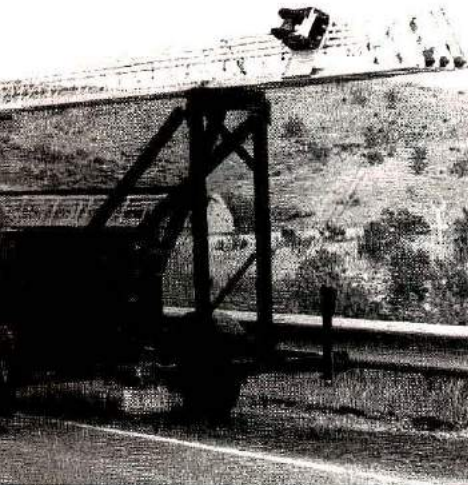

go home, towing the tower trailer. I would head toward the New York metropolitan area, scouting for sites to use next time (yes, there would be a next time, I vowed) and see if I could leave the van somewhere near Kennedy Airport.

After waiting an hour in a Sunday-morning gasoline line, I started south. Before long, my luck changed. I ran into Steve Katz, WB2WIK, working the contest on two-meter FM and asked him if there were any good mountaintops in his area.

It turned out that he knew of a million good radio locations all over New York and New Jersey. I visited his home (itself on a nice hilltop) and he drew me some maps. By this time it was late Sunday, but I went off to operate at least a few hours of the contest from a spot Steve recommended: Sheep Hill in Boonton, New Jersey.

trip East when there wasn't any contest to worry about, and use the van to scout the whole Northeast for good radio sites.

So that was trip number three. I flew East again in August and spent nearly two weeks doing nothing but visiting mountaintops. It was great fun and I got to operate from some of the classic mountaintops in the area, places like Mt. Greylock, Massachusetts, and Pack Monadnock, New Hampshire. I even drove all the way to North Carolina to check out the outer banks area near Kitty Hawk.

However, I ended up back where I started. In two weeks there was no way I could discover a super mountain overlooked by the locals for two centuries! All the really great locations were spoken for during the vhf contests.

I flew home again, wondering more than ever if this hadn't become the

tha." When we finally got there, we found it virtually inaccessible. My van simply wouldn't climb such a steep road, even without the trailer. And Tom's pickup blew a radiator hose on the way up.

Time for another reassessment. We were in the middle of nowhere, or so it seemed. We couldn't get up this mountain. The contest was well underway. Even worse, gasoline lines were forming at the few open stations, severely limiting our mobility.

We decided to split up. Tom would

I got there just in time to operate three hours of the vhf contest. The place is no Mt. Equinox, but Sheep Hill is indeed an exciting vhf location. Steve's friend Bill Radice, K2OWR, agreed to store my van, and Steve drove me to Kennedy Airport the next day.

Enroute home, I thought it over again. Two trips East for vhf contests and nothing but frustration. Wasn't this getting ridiculous?

I decided there was just one way to do this right. I would make a special

most ridiculous boondoggle of my life. It seemed like jousting with windmills, but I decided to give it one more try in the September, 1979, vhf contest.

The fourth time

On the way East on trip No. 4, I made myself a promise. When this one was over, there would be no more if it fizzled. I'd spent a small fortune and traveled 25,000 miles for this crazy scheme.

I landed at Newark, New Jersey,

VHF ODYSSEY

and Steve, WB2WIK, picked me up. He was planning a big vhf contest effort himself (at home), and his friend K2OWR was organizing a big multi-operator group effort on Sheep Hill, so he was busy. Since I had no assurance I would be able to operate on Mt. Equinox if I went there and had no alternate site, I felt like going off to Delaware on a lark.

Steve talked me out of it: "Give Equinox one more chance," he advised.

My morale was low when I drove up from New Jersey to Vermont that Friday night, but it seemed worth a try. With some trepidation, I drove on up Mt. Equinox the next morning — and discovered not a single other ham there! There was no sports car rally, and the managers of the inn said they had heard of no other hams planning to be there this time. So I put up my towers and antennas, working as quickly as one person alone probably can. I was ready to go when the contest started.

I got on the air and everything went too smoothly to believe. The equipment worked almost flawlessly and the action was heavy on all bands. By

Sunday afternoon, I felt sure I had a winning score.

Then the incredible happened. Suddenly 2 meters, 220 MHz, and 432 MHz came alive with signals from all over the Middle West. On bands where stations three hundred miles away are usually weak, stations in places like St. Louis, Missouri — half a continent away — were over S9.

I learned later that there had been a spectacular tropospheric band opening all over the Midwest all weekend long, and it had now spread far enough east that I could get in on the fun. But, while I worked Midwesterners as if they were locals, I began to realize something bizarre: Except for the W2SZ/1 multi-operator station atop nearby Mt. Greylock, no one along the "golden corridor" seemed to be working much of the DX to the west. The opening gradually spread all the way to Boston, but that was at the very end of the contest. During most of that Sunday evening, my single-operator competitors couldn't hear much of the DX I was working. After three frustrating trips from coast to coast, my luck had changed!

I left the van and trailer with W1SL and flew home the next day, almost in a state of euphoria. It took nearly the entire flight to Los Angeles to double-check my bulging log and compute the contest score. As the



On Mt. Equinox, but not for long. After this photo was taken, expedition No. 2 was abandoned over to a misunderstanding about who had permission to use the mountain.

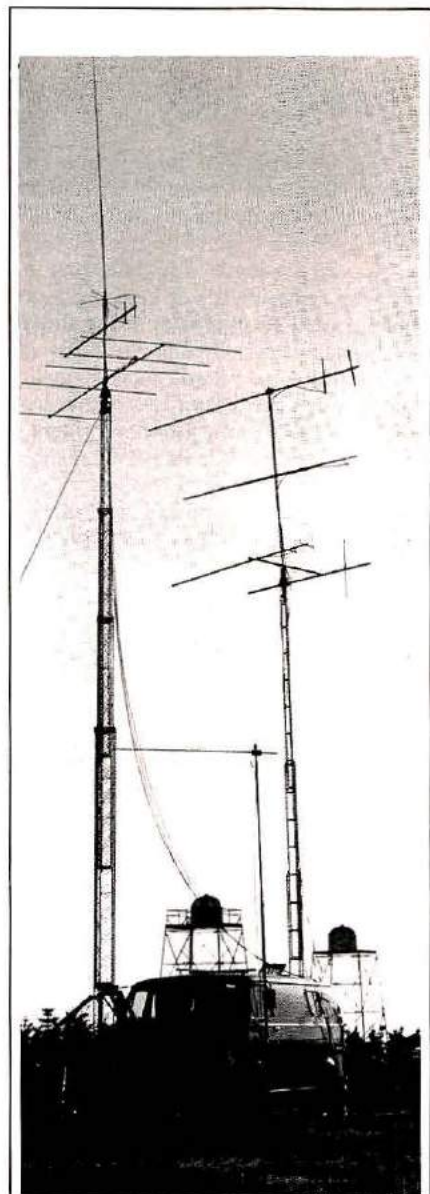

Success at last. This is the installation during the fourth vhf trip east. It resulted in an all-time record vhf contest score.

lights of the Las Vegas strip passed below, I finished tallying up the score — and couldn't believe what I saw. I had 102,795 points, more than double the all-time record for the September vhf contest, and the first six-figure score for a single-operator station in any ARRL vhf contest. I had won by a large margin.

Was it worth it? It wasn't cheap or easy, but this is definitely what we call a happy ending!

Lessee now, what would it take to set up a portable vhf station in the Swiss Alps and work all over Europe???

HRH

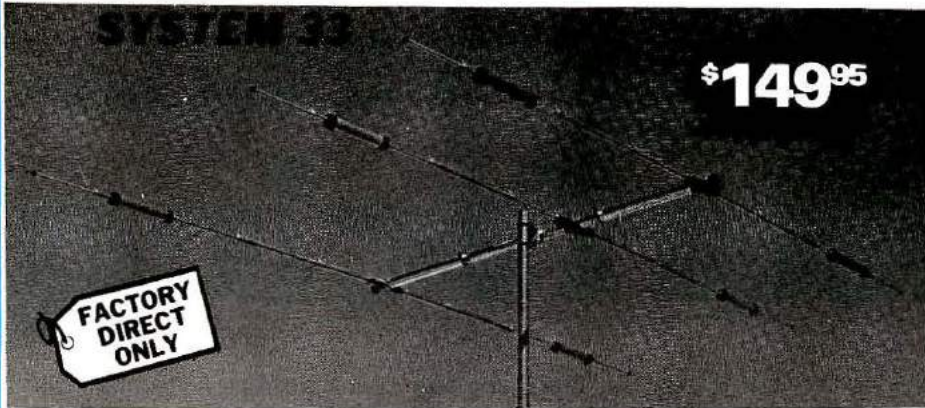

Capable of handling the Legal Limit, the **SYSTEM 33** is the finest compact tri-bander available to the amateur.

Designed and produced by one of the world's largest antenna manufacturers, the traditional quality of workmanship and materials excels with the **SYSTEM 33**.

New boom-to-element mount consists of two 1/8" thick formed aluminum plates that will provide more clamping and holding strength to prevent element misalignment.

Superior clamping power is obtained with the use of a rugged 1/4" thick aluminum plate for boom to mast mounting.

The use of large diameter High-Q Traps in the **SYSTEM 33** makes it a high performing tri-bander and at a very economical price.

A complete step-by-step illustrated instruction manual guides you to easy assembly and the lightweight antenna makes installation of the **SYSTEM 33** quick and simple.

SPECIFICATIONS

Band MHz. 14-21-28
 Max. power input . . . Legal limit
 Gain (dbd) Up to 8 dB
 VSWR at resonance 1.3:1
 Impedance 50 ohms
 F/B ratio 20 dB or better

Boom (O.D. x length) 2" x 14'4"
 No. elements 3
 Longest element 27'4"
 Turning radius 15'9"
 Max. mast diameter 2" O.D.
 Surface area 5.7 sq. ft.

Wind load @ 80 mph . . 114 lbs
 Assembled Wt. 37 lbs
 Shipping Wt. 42 lbs
 Direct 52 ohm feed
 no balun required
 Max wind survival . . . 100 mph

ACTUAL SWR CURVES

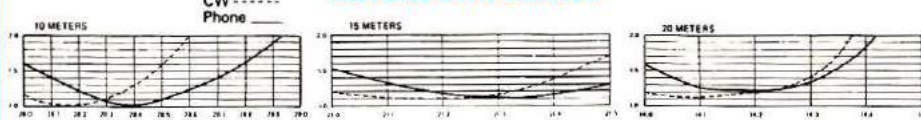

COMPARE THE SY33 WITH OTHERS...

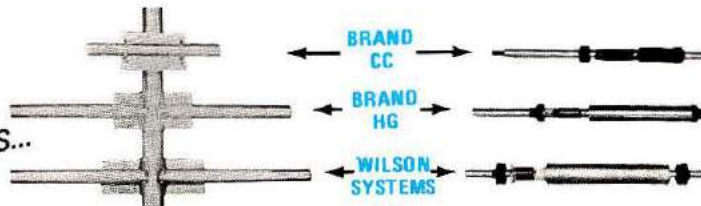

Compare the size and strength of the boom to element clamps. See who offers the largest and heaviest duty. Which would you prefer?

Wilson Systems traps offer a larger diameter trap coil and a larger outside housing, giving excellent Q and power capabilities.

NEW! **ADD 40 METERS TO YOUR TRI-BAND WITH THE NEW 33-6 MK** **\$49.95**
 — IN STOCK —

Now you can have the capabilities of 40-meter operation on the **SYSTEM 36** and **SYSTEM 33**. Using the same type high quality traps, the 40-meter addition will offer 200 KHZ of bandwidth at less than 2:1 SWR. The new 33-6 MK will fit your present SY36, SY33, or SY3 and use the same single feed line.

The 33-6 MK adds approximately 20' to the driven element of your tri-bander, increasing the tuning radius by 5 to 6 feet. This addition will offer an effective rotatable dipole at the same height of your beam. The 33-6 MK will not interfere with the operation of 10, 15 or 20 mtrs.



4286 S. Polaris Ave., Las Vegas, Nevada 89103

Prices and specifications subject to change without notice

ORDER FACTORY DIRECT 1-800-634-6898

\$49.95

WV-1A

4 BAND TRAP VERTICAL (10 - 40 METERS)

No bandswitching necessary with this vertical. An excellent low cost DX antenna with an electrical quarter wavelength on each band and low angle radiation. Advanced design provides low SWR and exceptionally flat response across the full width of each band.

Featured is the Wilson large diameter High-Q traps which will maintain resonant points with varying temperatures and humidity.

Easily assembled, the WV-1A is supplied with a base mount bracket to attach to vent pipe or to a mast driven in the ground.

Note: Radials are required for peak operation. (See GR-1 below)

SPECIFICATIONS

- 19' total height
- Self supporting — no guys required
- Weight — 14 lbs.
- Input impedance: 50 Ω
- Powerhandling capability: Legal Limit
- Two High-Q traps with large diameter coils
- Low angle radiation
- Omnidirectional performance
- Taper swaged aluminum tubing
- Automatic bandswitching
- Mast bracket furnished
- SWR: 1.1:1 or less on all bands

GR-1

\$12.95

The GR-1 is the complete ground radial kit for the WV-1A. It consists of: 150' of 7/14 stranded copper wire and heavy duty egg insulators, instructions. The GR-1 will increase the efficiency of the GR-1 by providing the correct counterpoise.

Station Interfacing

BY DOUG
BLAKESLEE, N1RM

Putting an Amateur Radio station together is a matter of individual preference. You can haywire equipment together so that it works after a fashion, or you can plan an arrangement that will look good when you invite visitors over and will reward you with operating convenience. In **Part 1*** of this article I showed how to use relays for station and antenna control, how to use ICs and transistors for linear-amplifier control, and how to connect an automatic-level-control (ALC) circuit. Also covered were transistor keying circuits for negative and positive voltages.

We'll now take a look at microphones — how to choose low- or high-impedance units; how to choose a loudspeaker for communications use, an audio filter, and a monitor oscilloscope — all to provide a tight and efficient station for radio communications.

Microphones

Two basic types of microphones are in use, low impedance (50-600 ohms) and high (typically 50,000 ohms and up). They are referred to as low Z and high Z, respectively. For years, a high-impedance crystal microphone was the standard for tube-type transmitters, which had high-impedance audio inputs. Some well-heeled Amateurs used dynamic microphones, which have low-impedance output but included a built-in miniature transformer for high-impedance output.

High-impedance coupling from microphone to transmitter involves the problems of rf pickup and attenuation by the connecting cables. Such difficulties were minimized by using an rf decoupling network at the input to the microphone amplifier in the transmit-

ter, and by keeping the connecting microphone cable short — 1.5 meters (5 feet) or less.

Microphone impedance — high or low Z: Today many manufacturers, especially in Japan, are using low-impedance dynamic microphones. Thus the first task is to determine the microphone input impedance of your transmitter. The specifications in the transmitter instruction book should

“You can haywire equipment together . . . or you can plan an arrangement that looks good . . .”

tell you. If not, look at the audio input circuit diagram, following it from the microphone connector. The first resistor you find from the audio lead to ground determines the impedance presented to the microphone. If an op amp is used as an audio amplifier, the resistor in series with the input to the integrated circuit sets the input impedance. If you find a resistor value of hundreds of ohms, up to 2000, the circuit is low impedance. Resistances of 25,000 ohms and above indicate high impedance.

A low-impedance microphone can be used with a high-impedance transmitter input if the transmitter audio stages have enough gain to work with a low-level signal. If not, either a transformer or preamplifier circuit can be used. Miniature, shielded microphone transformers are quite expensive, so a simple preamp such as shown in **Fig. 1A** is appropriate. This circuit uses the popular 741 op amp,

which costs less than \$1.00. C1 and RFC1 prevent rf energy from upsetting preamp operation.

To use a high impedance microphone with low-Z input, the circuit of **Fig. 1B** is appropriate. Again, the 741 is used. With either circuit, special precautions must be taken at the input to ensure that no rf gets in to foul up the works.

If you invest in a high-quality microphone, you'll want to use it for both your high-frequency rig and your vhf transceiver. You may want extra inputs in your rig for audio from a tape recorder and a phone patch. Some time ago I built a homemade patch¹ and included switches to select from several inputs and several outputs.

An audio mixer: A more elegant solution is to use a simple audio mixer with multiple outputs, such as shown in **Fig. 2**. The circuit has two inputs and two outputs. More of both types can be added if needed. An LM3900 IC is used, which contains four op amps that operate from a single-polarity power supply. The 3900 sells for less than \$1.00. The input amplifiers are high impedance so that they can be driven by either high- or low-Z microphones or other sources. The output stages are of the follower type. Always include one more input circuit and one more output than you think you'll need: sooner or later you'll want to add a Touch-Tone™† pad or whatever!

When building a box for your microphone circuits, include an extra jack or two for the push-to-talk (PTT) line. Then, if you want to add a foot switch or a remote control of some sort, just plug it in.

I added a push-button PTT function to my keyboard keyer so that I

†Trademark of American Telephone and Telegraph Company.

*In the April, 1980, issue of *Ham Radio Horizons*. Back issue available for \$2.

Part 2 of a two-part article on how to arrange your station for maximum efficiency and operating convenience.

Made Easy

wouldn't have to reach over to the transceiver at the beginning and end of each transmission. The circuit is given in Fig. 3. Cross-connected NAND gates U1A and U1B form a flip-flop to store the desired PTT status. An RC network ensures that the flip-flop always comes up in the RECEIVE mode when the power is turned on. I used a relay for PTT control; direct transistor switching will work as well.

After I hooked up my new PTT circuit and footswitch, I found that the IC-701 developed a strange malady. On 10 meters, as the drive was turned up, a point was reached where the speaker let out a growl and the power output went down as drive was increased. Obviously, rf was getting back into the rig through pickup on the long PTT leads. Adding two jumbo ferrite beads and a 0.01- μ F bypass capacitor to the PTT jacks in the microphone box cured the problem. It seems that every time you forget about the effects of rf interference on transistor equipment, something happens to remind you.

Speaker and audio filter

In the Hi-Fi trade there's a rule of thumb that you should spend at least as much on your speakers as on the rest of your equipment combined. A super speaker is not needed in the ham shack, but a good *communications* speaker is.

Communications through voice or CW uses the audio range from approximately 300 to 3000 Hz. High fidelity in this case is definitely *not* a speaker requirement — in fact, wide audio range is a detriment. Most receivers and transceivers have high levels of hum output. Thus, the less response below 300 Hz the better, which means a small speaker — 10 or 15 cm (4 to 6 inch) diameter — is more than adequate. High-frequency

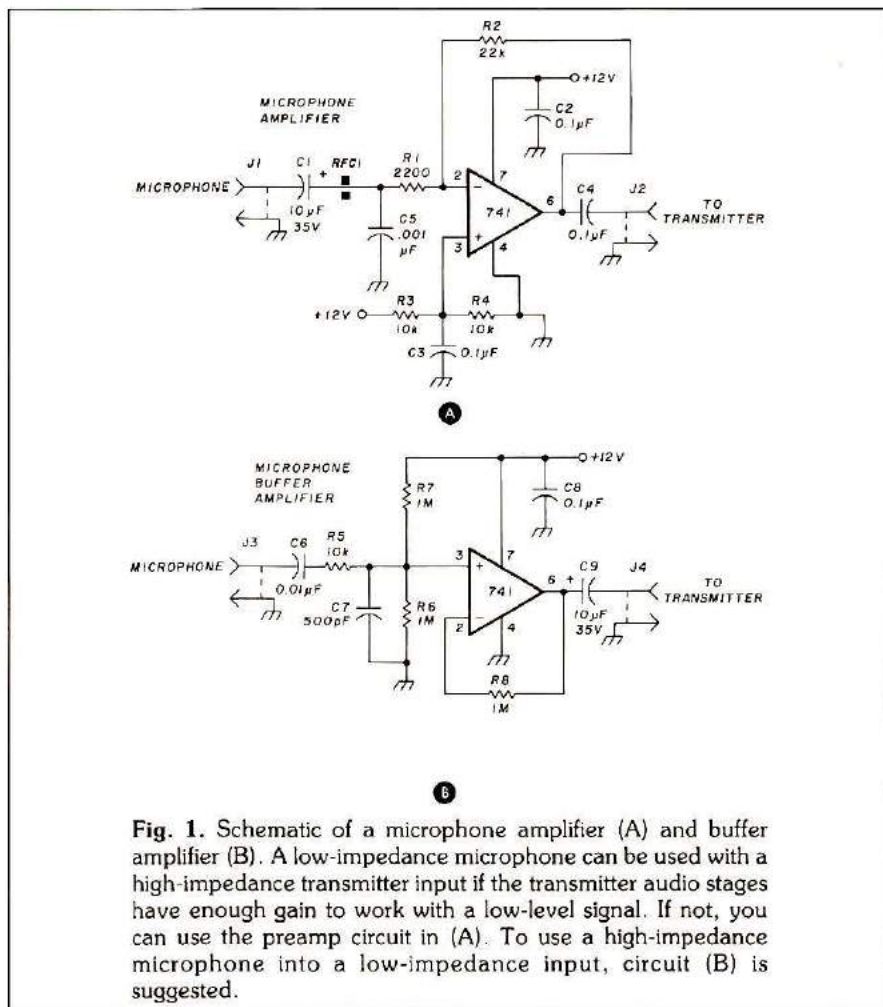

Fig. 1. Schematic of a microphone amplifier (A) and buffer amplifier (B). A low-impedance microphone can be used with a high-impedance transmitter input if the transmitter audio stages have enough gain to work with a low-level signal. If not, you can use the preamp circuit in (A). To use a high-impedance microphone into a low-impedance input, circuit (B) is suggested.

response, which tends to emphasize noise and heterodynes above 3000 Hz, is also undesirable.

For years I used a small Johnson speaker and enclosure built to go with their two-way mobile radios. Similar units from General Electric and Motorola are also excellent choices, because they were designed for communications service. Run a check on any new speaker to ensure it sounds "clean."

Testing speakers: It's easy to test a speaker and its enclosure for unwanted resonance points. Find a steady,

unmodulated carrier — a crystal-calibrator signal is ideal. With the receiver or transceiver set to receive SSB and with the audio (volume) control adjusted so that the resulting heterodyne is moderately loud, very slowly tune from zero beat up through the highest audio frequency you can hear. One or more resonance point will be noted; at each point the sound will be distorted or tinny. Generally there will be a low-frequency resonance, which is caused by the speaker cone, and a second, which is a resonance of the speaker plus enclosure. The latter is most troublesome because it's often in

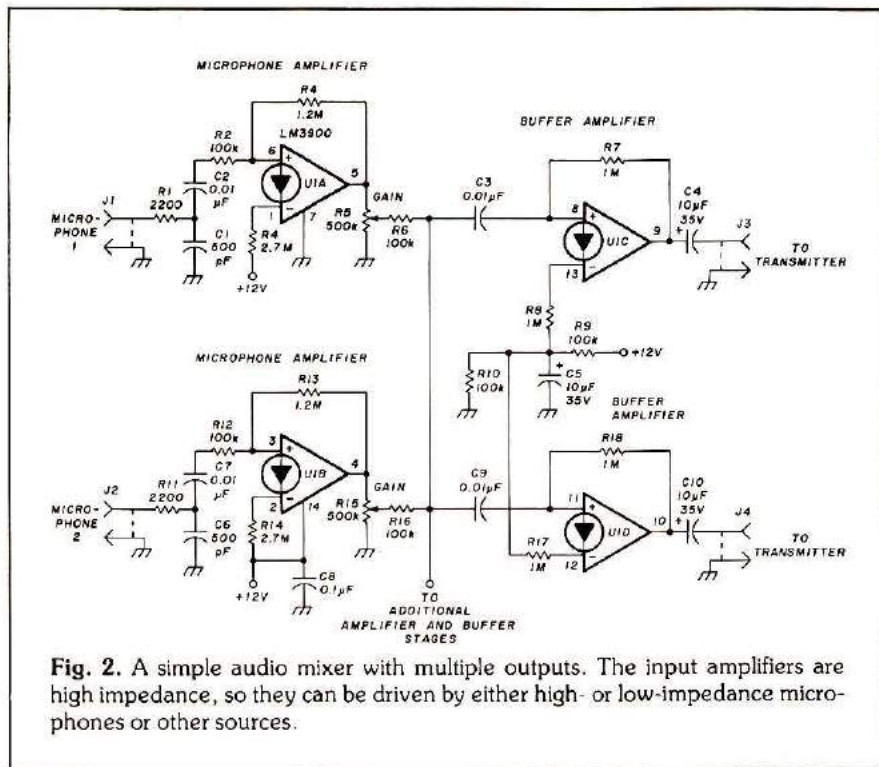

the middle of the desired audio range.

If you have a speaker loaded with resonant points, it's best to try another unit. Cone resonance can be damped and lowered in frequency by choice of the enclosure size and by packing the inside with a sound-absorbing material such as fiberglass. My Johnson speaker originally had a resonance at 750 Hz, which was cured after drilling four 1/4-inch (6.5-mm) holes in the rear of the enclosure and packing the interior with fiberglass.

The audio quality from speakers built into today's transceivers is usually poor to awful. The speaker is often a cheap afterthought bolted to a metal cover or mount, with no enclosure or baffling. Thus, I didn't expect much when I ran the resonance test on the speaker built into the ICOM power supply. But it sounded great, not only in the tone test. Voice reproduction was clean and crisp. I wired a switch so that I could conveniently change from the ICOM to the Johnson speakers. After many years of service, the Johnson unit has been retired to a basement shelf!

Some older ham receivers and most military surplus types have 600-ohm audio-output impedance. Thus, to match a 4- or 8-ohm speaker requires a transformer. When I acquired my R390-A receiver, a quick check of a commercial transformer catalog

brought instant cardiac arrest of the wallet: a suitable transformer was \$35!

Two low-cost alternatives were found. A transistor-radio audio-output transformer with 1000-ohm, center-tapped primary and an 8-ohm secondary was tried, using one-half of the primary winding. It worked well. Even less expensive are the 70.7-volt constant-voltage transformers made for public address systems. They have a multitap primary and 8-ohm secondary. Connected as shown in Fig. 4, this transformer also provided an adequate impedance match.

Audio filter: Anyone who hasn't tried an audio filter is missing a great reception aid. I've yet to see the receiver that wasn't improved by a quality filter. One drawback to audio filters is that they often aren't easy to install. Cutting into a receiver or transceiver to hook up a filter is an unpleasant, often impossible, task. One look at the innards of my ICOM convinced me that the IC-701 was definitely in the impossible category.

Audio filters are available with the filter alone, filter plus audio amplifier, or filter-amplifier with integral power supply. I have an AUTEK QF-1, which is in the latter category. Even though it's a self-contained unit, it lacks conveniences such as a cutout switch, provision for a second receiver input and a jack for a speaker.

My simple modifications to the QF-1 are shown in Fig. 5. I added an input for a second receiver so that both my IC-701 and R390-A could be used with the filter and the excellent ICOM speaker. The inputs from both receivers are loaded with 10-ohm resistors and isolated from each other with 10-ohm units.

There are times when you want the filter out of the speaker circuit, but few commercial filters have a bypass provision. I added switch S1 to accomplish this task. W1FB had a more elegant solution for his AUTEK. He added a relay powered by the QF-1 dc supply to provide the S1 function. Thus, his filter is out of the circuit when the power control switch on the unit is in the off position. The final modification was to add a provision for a speaker output in addition to the

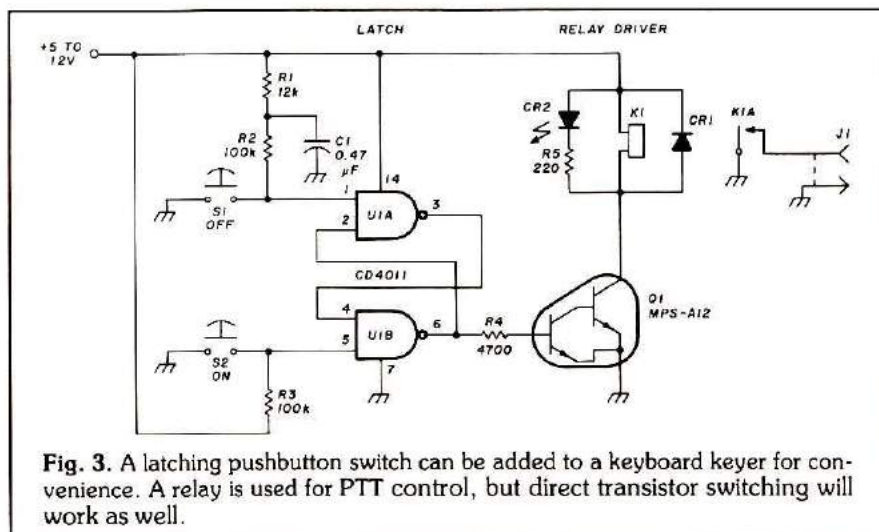

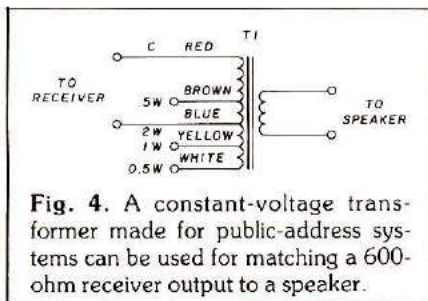

Fig. 4. A constant-voltage transformer made for public-address systems can be used for matching a 600-ohm receiver output to a speaker.

headphone jack built into the QF-1.

What to do if you only have a filter but no power source? Dc power can be obtained from an auxiliary power supply as described in **Part 1** of this article. An audio amplifier can be constructed in a matter of minutes using an LM380 integrated circuit and the diagram of **Fig. 6**. This IC will provide 1-2 watts of audio output. Before acquiring the AUTEK, I used a homemade audio filter, which I built into a telephone amplifier. The telephone accessory contained an amplifier, speaker and power supply. I borrowed dc power for my filter from the unit.

Including a second receiver

My R390-A general-coverage receiver was mentioned earlier. The interface problem for a second receiver consists of providing an antenna connection and provision for muting when transmitting.

The antenna connection may take some experimentation. If your transceiver has an antenna output for a second receiver, try connecting the receiver while listening to a weak signal on the transceiver. If the weak-signal level remains unchanged, all is okay. When I tried this experiment with a Yaesu transceiver and the R390-A, the weak signal went away. Inspection of the Yaesu schematic indicated that the R390-A antenna-input coil in this case was connected in parallel with the transceiver input coil, with unhappy results. I found that a small coupling capacitor, shown in **Fig. 7**, isolated the two receivers without attenuating the signals to the R390-A. Thus, both units could be used with the same antenna simultaneously.

The IC-701 has no provision for an external receiver. It does, however, have the receiver input looped through external panel jacks for use

with a vhf transverter. I connected to the receiver input at this point. Again, the weak signal went away. I tried the coupling-capacitor trick, but in this case the R390-A was dead. Obviously, the attenuation across the capacitor was excessive. I couldn't find any way to make the two rigs like each other. So, I had to settle for a small coaxial relay, which routed the antenna to either the IC-701 or the R390-A.

Monitor scope

Usually interconnecting a monitor oscilloscope with your station is a sim-

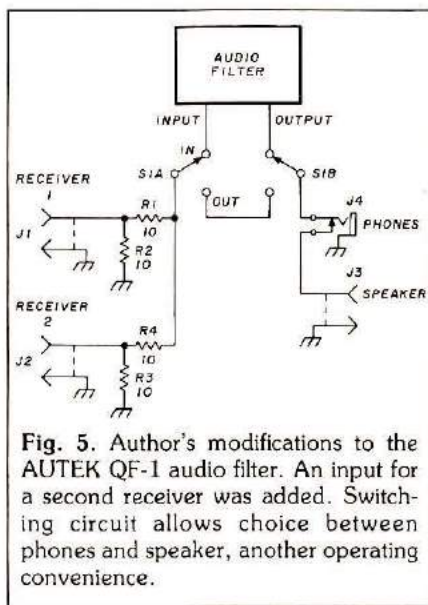

Fig. 5. Author's modifications to the AUTEK QF-1 audio filter. An input for a second receiver was added. Switching circuit allows choice between phones and speaker, another operating convenience.

ple matter — just follow the manufacturer's instructions. However, immediately after hooking up my newly completed Heath SB-614 I noticed that my SWR reading on 15 meters had gone way up. I switched to another antenna. Same high SWR. It didn't seem reasonable that the Heath scope was the cause of the problem, so I assumed that the difficulty was in the connections I'd just made.

A block diagram of my antenna cabling is shown in **Fig. 8**. (Eight coax interconnecting cables!) My first step was to connect a dummy load to one of the antenna-switch outputs. The dummy load showed a high SWR. Then I removed one cable at a time, moving the dummy load ever closer to the exciter. Soon I found the culprit — a 6-foot (1.8-meter) piece of 72-ohm cable had been inadvertently used between the scope and the SWR

bridge. All the other cables were 50 ohms.

Do you need a monitor scope? Well, it's in the luxury class of station accessories. However, the popular ham transmission modes — CW, SSB, RTTY — involve rapidly changing signals. The oscilloscope is the best tool ever invented for examining dynamic signals.

When I first installed my IC-701 I noticed the CW waveform was well shaped on the leading edge but had a sharply falling characteristic on the trailing side, an indication of a click generator. (Key clicks are byproducts of the keying process, which produce interference on both sides of a CW signal if the carrier is allowed to rise or fall too rapidly.) To check I listened on the R390-A with its antenna input shorted. Sure enough, when I depressed the key the signal sounded clean. But when I let it up, there was a click of objectionable proportions. (More work!) I also noted that I had to be very careful with the microphone gain control when operating SSB. Turning the microphone gain up only 10 per cent was sufficient to overdrive the final amplifier, as indicated by flattening of the speech waveform. Thus, a monitor scope can be very useful when getting to know a new rig.

Construction hints

In this article a number of simple projects have been presented. For complex circuits an etched circuit board is ideal. For simple interface units, either perforated board or universal PC boards are appropriate. The universal boards have simple etched patterns intended for IC projects but are usable for most circuits.

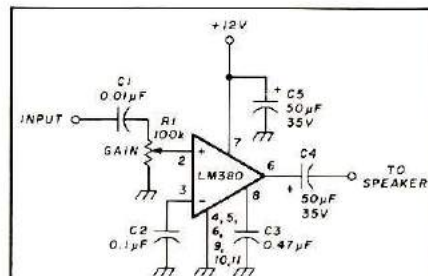

Fig. 6. Simple audio amplifier using the LM380 IC. Circuit provides 1-2 watts of audio power, uses available parts, and can be assembled in a matter of minutes.

Reliability Service Experience



**KENWOOD
TR-9000**



Check our price last!

Up Your Hand-Held Power with VoCom Power Amplifiers

Model 2C025 - 200 mW	\$74.95
Model 2C025-2W	\$62.95
Model 2C050-2W	\$99.95
Model 2C100-2W	\$152.95

**ALLIANCE
HD-73
\$109.95
prepaid**

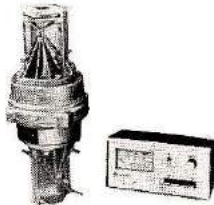

**KENWOOD
TR-2400**



Check our price last!

**PREPAID SHIPPING
CONTINENTAL 48 ONLY**

Quantities limited. Michigan residents add 4% sales tax. Please include your area code and telephone number with any correspondence.



RSE HAM SHACK

1207 W. 14 MILE, CLAWSON, MI 48017
(313) 435-5660

31155 PLYMOUTH, LIVONIA, MI 48150
(313) 522-4232

**MAIL ORDER TELEPHONE
(313) 435-5660**

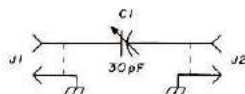

Fig. 7. A simple circuit for coupling two receivers with minimum input attenuation.

The cost of a universal board may seem high until you consider that you can cut it up and get four or five small projects out of one board.

The first step with either type of board is to run it through a copy machine at your local post office or library. The copy of the etched or hole pattern is used to lay out circuit connections. Use a red pencil for clarity. When your wiring plan is done, follow it when mounting parts and soldering

icates a short or a defective semiconductor device. A high reading — over 50000 ohms — also indicates that all isn't correct in a semiconductor circuit. Once the power is applied you can troubleshoot a switching circuit with a voltmeter. Check each stage for appropriate voltage levels and changes. A pair of high-impedance headphones, isolated by a 0.1- μ F capacitor, can be used to trace audio signals.

In closing

Most interfacing problems can be resolved if you think the problem through. Tinkering is often necessary, so don't be reticent about experimenting. It's often the little projects you build yourself that produce a topnotch communications station.

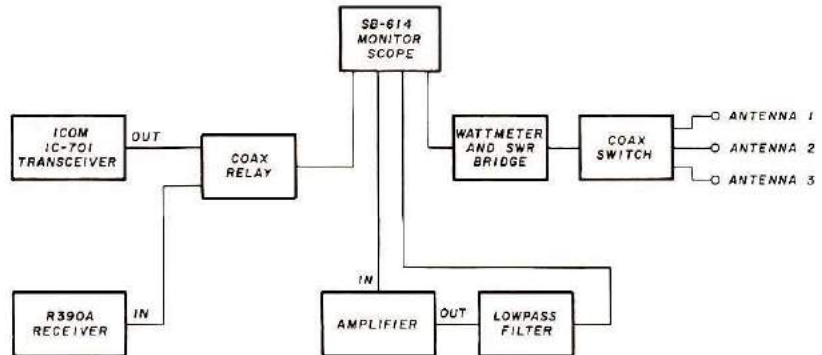

Fig. 8. Block diagram of antenna-cabling scheme used in author's station. Make sure all interconnecting cables are of the same impedance (see text).

interconnections. It should take less than an hour to have most of the projects described in this article assembled and ready to mount in an appropriate housing.

Once your project is assembled, carefully check the orientation of components with regard to polarity, such as transistors, diodes and polarized capacitors. Check solder joints. Poorly soldered connections are the most common cause of trouble. If the solder is not bright and shiny, reheat the joint until the solder flows again. Be careful about heat transfer to adjacent components.

To eliminate the traditional smoke test, check the resistance of the power leads with an ohmmeter. A very low resistance — tens of ohms — indi-

Further Reading

1. Doug Blakeslee, N1RM, "A Phone Patch for the Collins S-Line," *QST*, December, 1969.
2. Karl T. Thurber, Jr., W8FX, "Station Design, Part 1, How to Plan the Site for your Ham Station and Set Up Your Equipment," *Ham Radio Horizons*, August, 1978, page 44.
3. Karl T. Thurber, Jr., W8FX, "Station Design, Part 2, Equipment Placement and Wiring Tips for Improved Efficiency and Operating Comfort," *Ham Radio Horizons*, October, 1978, page 12.
4. Karl T. Thurber, Jr., W8FX, "Station Design, Part 3, Tips on Making Your Station Safe for You and Others and Some Advice on How to Cope with Emergencies," *Ham Radio Horizons*, November, 1978, page 44.

HRH

Yesterday you could admire all-band digital tuning in a short wave receiver.* Today you can afford it.



RF-4900

Tune in the Panasonic Command Series™ top-of-the-line RF-4900. Everything you want in short wave at a surprisingly affordable price. Like fluorescent all-band readout with a five-digit

frequency display. It's so accurate (within 1 kHz, to be exact), you can tune in a station even before it's broadcasting. And with the RF-4900's eight short wave bands, you can choose any broadcast between 1.6 and 31 MHz. That's all short wave bands. That's Panasonic.

And what you see on the outside is just a small part of what Panasonic gives you inside. There's a double superheterodyne system for sharp reception stability and selectivity as well as image rejection. An input-tuned RF amplifier with a 3-ganged variable tuning capacitor for excellent sensitivity and frequency linearity. Ladder-type ceramic filters to reduce frequency interference. And even an antenna trimmer that changes the front-end capacitance for reception of weak broadcast signals.

To help you control all that sophisticated circuitry, Panasonic's RF-4900 gives you all these sophisticated controls. Like an all-gear-drive

tuning control to prevent "backlash." Separate wide/narrow bandwidth selectors for crisp reception even in crowded conditions. Adjustable calibration for easy tuning to exact frequencies. A BFO pitch

control. RF-gain control for improved reception in strong signal areas. An ANL switch. Even separate bass and treble controls.

And if all that short wave isn't enough. There's more. Like SSB (single sideband) amateur radio. All 40 CB channels. Ship to shore. Even Morse communications. AC/DC operation. And with

Panasonic's 4" full-range speaker, the big sound of AM and FM will really sound big. There's also the Panasonic RF-2900. It has most of the features of the RF-4900, but it costs a lot less.

The Command Series from Panasonic. If you had short wave receivers as good. You wouldn't still be reading. You'd be listening.

*Short wave reception will vary with antenna, weather conditions, operator's geographic location and other factors. An outside antenna may be required for maximum short wave reception.



RF-2900

Panasonic
just slightly ahead of our time.

A persistent CW signal,
crying for help.

Giuseppe Biagi, center, and the crew
of the *Italia*

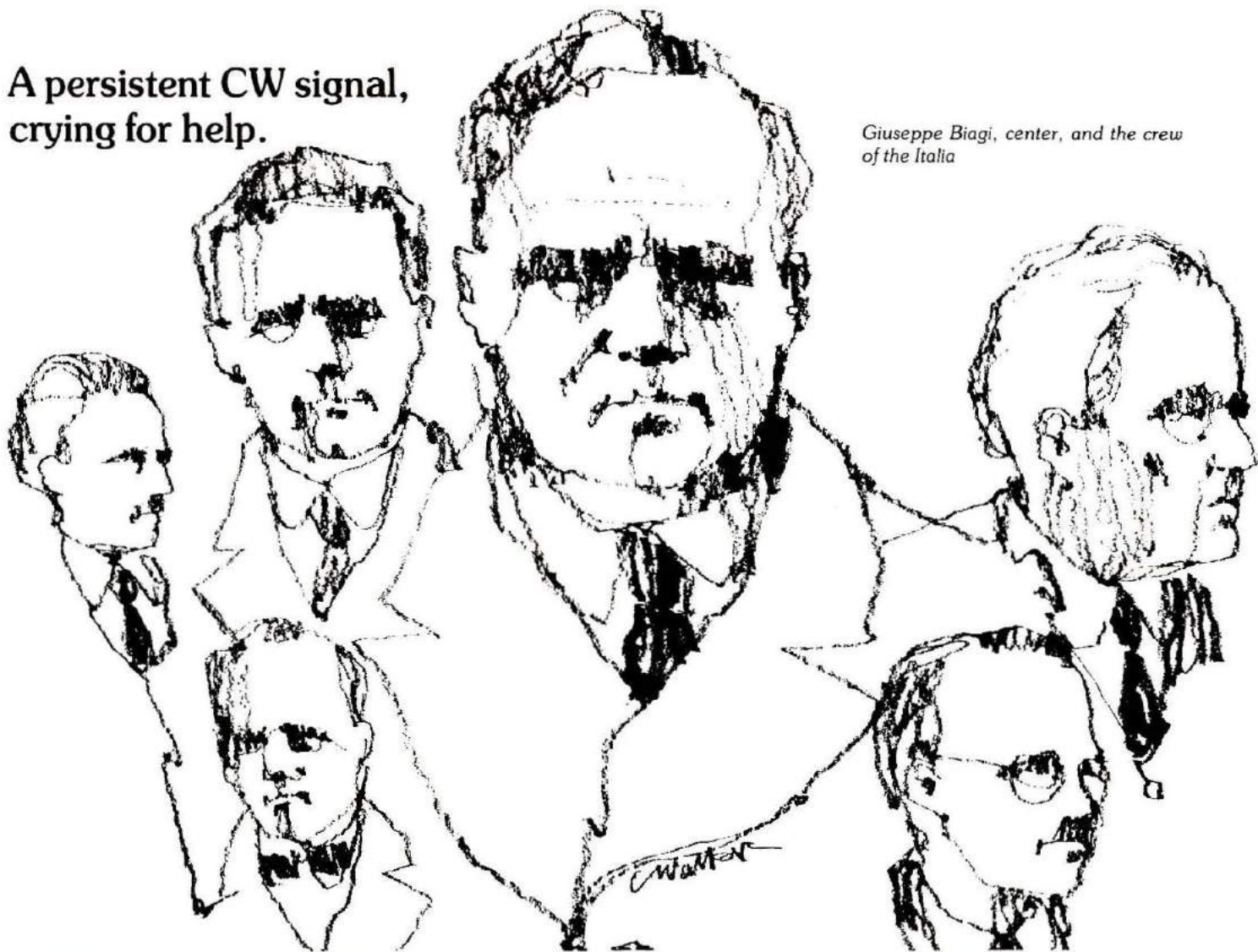

The Forgotten Hero

BY HENRY MORRISON, W5RIY

Every day, there are dozens of routine flights over the North Pole. Fifty years ago similar approaches over the Pole called for expeditions. The man at the radio was an all-important link. Many have been forgotten, but the men of the *Italia* will remember Giuseppe Biagi, Radio Operator, as their link with the world and rescuer from certain death.

It seems like a long time ago that an Italian dirigible built by Colonel Umberto Nobile made the first successful flight over the North Pole with a crew composed of Italians, Norwegians, and Americans. On board were such famous arctic explorers as Amundsen, Ellsworth, Riiser-Larsen, and Nobile as the pilot. That was the flight of the *Norge*. Radio was there

and electrified the world, even though, at times, the ship's aerial was so encased in thick ice that the radio was useless. All this, just a little over fifty years ago.

In May, 1927, the dramatic solo flight of Lindbergh made the world conscious of aviation and radio. Mussolini promised the Italian Royal Geographic Society a crew and airship if the city of Milan paid the expenses for another polar flight. Nobile designed the *Italia*. It was the finest of the day, with a small radio room in the rear of the main cabin. The radio antenna had been designed to be pulled into the control car when it became covered with ice. Steady electrical power for the radios came from outboard wind-driven generators.

The radio equipment was the best; from a large volunteer group of radio operators, Ettore Pedretti and Giuseppe Biagi were chosen. They checked and completed the radio installation. Emergency transmitters and heavy-duty batteries were added, as well as extra wire. They tried to plan for every communications problem. Survival items were given special attention and included two sledges, snowshoes, skis, Vickers rifles, seal-hunters' rifles, Colt revolvers, and mosquito netting. A special pemmican mixture was prepared for emergency use, and attention to clothing found no one wanting.

Captain Romagna, in command of the steamship *City of Milan*, left on March 19, 1928, with extra engines

and supplies. On April 15, with twenty aboard, the *Italia* started its flight north out of Italy. The radio operators maintained a watch, but sometimes lost contact, such as when the *Italia* was caught in violent electrical storms or dropped into mountain passes.

It was not until May 3rd that the airship left Stolp, Germany, after needed repairs, brought on by a hailstorm so fierce that it had even pitted the propellers. Radio watch continued, and, over the Barents Sea, the warning came of a depression that was creating a storm of gale force. They sped toward Vadso, (now Vardo, in northern Norway).

The storm in Vadso became so dangerous that Nobile felt the ship would be safer in flight above the storm. The Bear Island meteorological station furnished weather reports, and they went off course to pass over the island. Messages were exchanged with the two isolated weathermen whose reports were so important.

By May 23rd, all was ready. The *Italia* had taken on supplies from the *City of Milan*, and radio contact and schedules had been set up with ship's operator Baccarani. Radio batteries were fully charged and equipment checked. Ettore Pedretti was to stay with the *City of Milan*, and Giuseppe Biagi would be the radio operator to fly over the pole aboard the *Italia*.

On May 23rd, at 4:28 A.M., the ground crew freed the *Italia*. Biagi transmitted the course and speed information, and then copied weather reports as the *Italia* headed north. Progress reports continued, and by 11:00 P.M. they were within fifty-five miles of the North Pole. At midnight, first officer Mariano made a sextant reading, and about twenty minutes later ordered the engines slowed and announced they were over the pole. They steered in a circle and dropped markers. Biagi keyed the transmitter with messages to the King of Italy, the Pope, and Mussolini.

Aboard the *City of Milan*, newspaper men waited outside the radio room. Captain Romagna suddenly appeared and angrily told them to leave. He did not tell them the *Italia* had crossed the pole; he felt the announcement should come from Italy. After some time, Rome proudly informed the world they had again sent an airship over the North Pole.

For twenty-four hours the *Italia* worked toward King's Bay and the safety of the *City of Milan*. Biagi received a steady flow of weather reports which indicated high winds and storm conditions. They were now flying in fog at about five hundred feet, and it was not long before ice began to form over the *Italia*. The ice was cause for worry; Biagi brought in the antenna with icicles two inches thick. Communications were difficult and the radio signals gave only approximate position figures. Hurricane winds continued, and blew the *Italia* off course. By 7 A.M. the wind was so strong no headway was made, and a course toward North-East Land was taken. Radio communications con-



Nobile in Arctic flying gear

tinued poor. At about 9:30, Nobile ran from the radio room when a cry came that the elevator wheel was jammed. The ship settled toward the ice. Only ninety yards above the ice pack, they dropped the ballast chain, which let them rise slowly out of the fog into the sunlight.

By 10:30 A.M. the airship's nose was up 8 degrees but the *Italia* was falling a half-yard per second. Engines were speeded up, but the drop was faster. A crash was coming!

The engines were stopped. Biagi was trying to reach the *City of Milan*, transmitting a position report, when the *Italia* slammed into the ice. The control car broke free and the gas en-

velope drifted away, nose up. Biagi was knocked unconscious.

There was disbelief that this could have happened; they were suddenly on the ice pack with no tent, food, radio, or sledges, and several were injured. Everyone was in a state of shock.

When Biagi came to, he found the field station for emergency use was intact. All of the hand tools had fallen into the snow. He found a box of rations and hope returned. Two waterproof bags strapped to the ceiling of the radio room contained provisions and a tent, plus a sleeping bag. They found pemmican, chocolate, a Colt revolver, a Very signal pistol, and a carton of matches.

Biagi searched for more salvage and came upon one of the wrecked gondola cars that held the stern engine. He found a pair of shoes. Biagi helped put the tent up, and then started work on setting the radio in working order. They moved to a flat surface of ice and made their camp in the growing cold. While others tried to improve the camp, Biagi had an antenna up and was operating a battery transmitter, sending an SOS to the *City of Milan*. The receiver was in the tent. He would transmit, hurry to the tent and listen, and then return to transmit SOS. No answer.

Biagi sent SOS every fifty-five minutes, and prayed that *City of Milan* radio operator, Baccarani, would answer. By nightfall, the quiet of the arctic, and their failure to be heard on the radio, brought fear. Biagi kept at his vigil all night. Nothing was heard.

The second day soon became the third. Biagi was now sending his SOS every two hours. The cold was taking a slow hold on the batteries. Although the equipment was the very best of its kind, some survivors were beginning to have doubts about the radio, about Biagi, and about the *City of Milan* — whether anyone was bothering to listen. Morale was shaky, but with something to do, like finding fresh snow for drinking water and searching for wreckage, the thought that somehow they would be rescued kept each man going. The receiver worked but the signals went unanswered.

The failure to hear the *Italia* set rescue preparations into motion in many countries. The U.S. Navy considered sending the *Los Angeles*. Swedes,

Finns, and Russians volunteered, and Amundsen was ready to start. "We imagine you are near the north coast of Svalbard, between the 15 and 16 meridian," wired the *City of Milan*. "We are organizing help. Trust us." Biagi received this message, but the search was not going to be in the right area. Biagi believed his signals were "skipping," but the others felt the *City of Milan* operators were not listening. The San Paolo relay-station bulletins told nothing of rescue attempts, and Biagi heard wild theories of what had happened.

The ice continued to drift eastward. By the fifth day the radio was regarded by several as useless. Every two hours Biagi continued the SOS, then listened, but with no results. The *City of Milan* continued to transmit personal telegrams and newspaper reports. Captain Romagna was certain Biagi was dead and said, "Biagi leaned out the porthole. The radio propellers came loose and cut off his head." The last contact was just before the crash, 10:30 A.M., May 25th. They had heard nothing since.

The reserve operator, Pedretti, continued to monitor intently during the times when the *City of Milan* wasn't transmitting to San Paolo. He heard the word "ITALIA" on May 29th, and copied, "Reply via IDO 32K."

Pedretti pleaded with chief operator Baccarani to believe that the *Italia* had called. "Ido" was the code word for San Paolo; "32" the airship's wavelength; "K" meant hurry up, answer us. Baccarani said it wasn't possible; he had heard Magadiscio. Baccarani was so certain the captain was right that he did not check with Magadiscio to see if they had transmitted.

Some of the survivors on the ice wanted to build a sled and start marching toward what they hoped would be safety. There were only four who could possibly do so, and one was Biagi. For Biagi to leave would mean the loss of any radio contact. After careful discussion, Biagi decided to stay with the radio, although at first he thought the march would be fastest.

The most important events in the survivors' lives were the 9 o'clock news bulletin from San Paolo, and the evening meal. The ice continued to drift eastward and Biagi continued

his routine of SOS every two hours, listening, and praying the batteries would not fail in the cold.

Three survivors prepared to march. They requested the radio not be used for twenty or twenty-five days so the batteries would be saved and give them time to get help and a boat as near as possible. The marchers would make less than six miles on any given day.

Not using the radio was out of the question. Nobile wrote a message in Italian and French and gave it to Biagi with instructions to transmit the message for one full hour every day. June



3rd, the tenth day on the ice pack, found the cold getting worse, the pack drifting faster. Despondency began to set in. Biagi began to lose faith in his radio. He listened hourly.

Suddenly Biagi came alive with a shout, "They've heard us!" He wrote as fast as his cold, stiff fingers would permit, and read aloud, "The Soviet Embassy has informed the Italian government . . ."

A Russian farmer named Schmidt, in Archangel, had heard bits and pieces of the June 3 SOS. While there was joy on the ice floe, there were few outside the Soviet Union who believed the Russian operator had heard the *Italia*, and those at King's Bay said it was a hoax.

It was the 14th day on the ice, and Biagi transmitted and copied a bulletin. An American Radio Amateur in-

tercepted a radiogram. "No shelter except remains *Italia* which crashed against mountain," read the false report. A position near the 85th parallel in the Arctic Ocean was given. This hoax made Schmidt's true report less acceptable.

Moments later, Biagi copied a newspaper dispatch from the *City of Milan*. That morning, a supply ship had heard fragments of "SOS FRANCESCO," and believed it to be from the *Italia*. Biagi let out a scream of delight, "They ran 'Foyn' and 'circa' together and mistook it for Francesco! They heard us!" The dispatch continued, "The Italian officials feel the message is a fabrication." Morale on the ice floe dropped to a new low.

Biagi continued to listen. The next day a new message was transmitted, "SOS ITALIA Nobile longitude twenty-eight degrees east, about twenty miles northeast coast Spitsbergen." The day passed.

Pages of news were transmitted in the evening, and then "ITALIA ITALIA" brought Biagi to life. "The *City of Milan* heard you clearly this morning. Coordinates received. Give Biagi's registration number." Everyone waited for the acknowledgment of Biagi's reply.

The 16th day brought further hope with a message from the *City of Milan*. "Be ready to make smoke signal. Airplanes will . . ." and the message was lost in the fading and noise of arctic communications "white water."

Biagi transmitted that they would send up smoke and Very lights, gave the local weather conditions, a request for provisions, as well as what they believed would be the position of the three men who were marching on the pack. His steady CW added, "The batteries will run out shortly but we can still receive." Nobile radioed for medical equipment, a collapsible boat, and advised that a hydroplane be sent. The *City of Milan* cut them off. "You better save batteries. Our business to speed up rescue work. Three Swedish planes on way. Ship *Hobby* near Baffin Island blocked in ice. Russians preparing icebreaker. Dog teams to meet three marching for Cape North."

The 18th day brought a report of seven different groups moving toward their rescue. It was announced that

Amundsen would head a group. Two Russian icebreakers, *Malygin* and *Krassin*, were moving toward them, and the men of the *Italia* felt the ships would push through until they were rescued. Everyone had new faith in the radio.

But then came a wind shift and a storm; the wind blowing them toward the open sea, and the storm blocking radio contact. It was necessary to move to another floe.

For the next few days, communication was poor, but Biagi was told the *City of Milan* would listen for them only at 8:55 P.M. Only fragments of Biagi's transmissions were received. The *City of Milan* each night would report there was nothing new and no change. Instead of listening for Biagi's reply, regular traffic with San Paolo would be resumed.

Nobile was angry. He sent a request the *City of Milan* listen for at least ten minutes after calling. It was three days before the ship's radio operators changed procedures, and

then Nobile wired, "Could not give you our coordinates because you persist in listening only at 8:55 P.M. when reception is very bad. Romagna should send at once minimum supplies. Situation still dangerous." The new location was sent.

A faint sound was heard and smoke from the signal fires went up. Two planes came within miles and turned away from the camp. Biagi radioed that the planes were seen but turned away. The *City of Milan* told them, "Next day at the same hour."

Everyone waited, but there was nothing the next day. On June 19th they heard a plane but it also turned and disappeared. Yet another plane came close, but it also turned without contact.

The 27th day on the ice pack Biagi copied, "A plane carrying a radio" had taken off. On the pack, smoke signals and Very lights were ready, Biagi was at the radio, metal had been shined to reflect light, and all waited. At 7:30 radio contact was made. A

hydroplane appeared and by radio Biagi gave directions. The plane came within 100 yards and Biagi sent "VVV," the signal meaning they were on top of the camp. The plane turned, and suddenly it appeared to be lost and again searching for the men. It was half an hour before Biagi made contact with the plane and guided it back. "KKK" was sent. This was the code to drop the provisions. Packages rained down and the plane wheeled and headed south. Leather shoes, collapsible boats, sleeping bags, rifles, shattered batteries, and provisions. Instead of pemmican and chocolate they had oranges, lemons, marmalade, cocoa, fifty bananas, and thirty freshly broken eggs.

That night the CW painfully asked for better packaged batteries, pemmican, a Primus stove, medicine, snow glasses, and the largest size shoes for one of the men. The next day fourteen drops contained enough provisions for twenty days. There was medicine, a rifle, a carton of ciga-

Making ready for the *Italia*'s last, disastrous flight

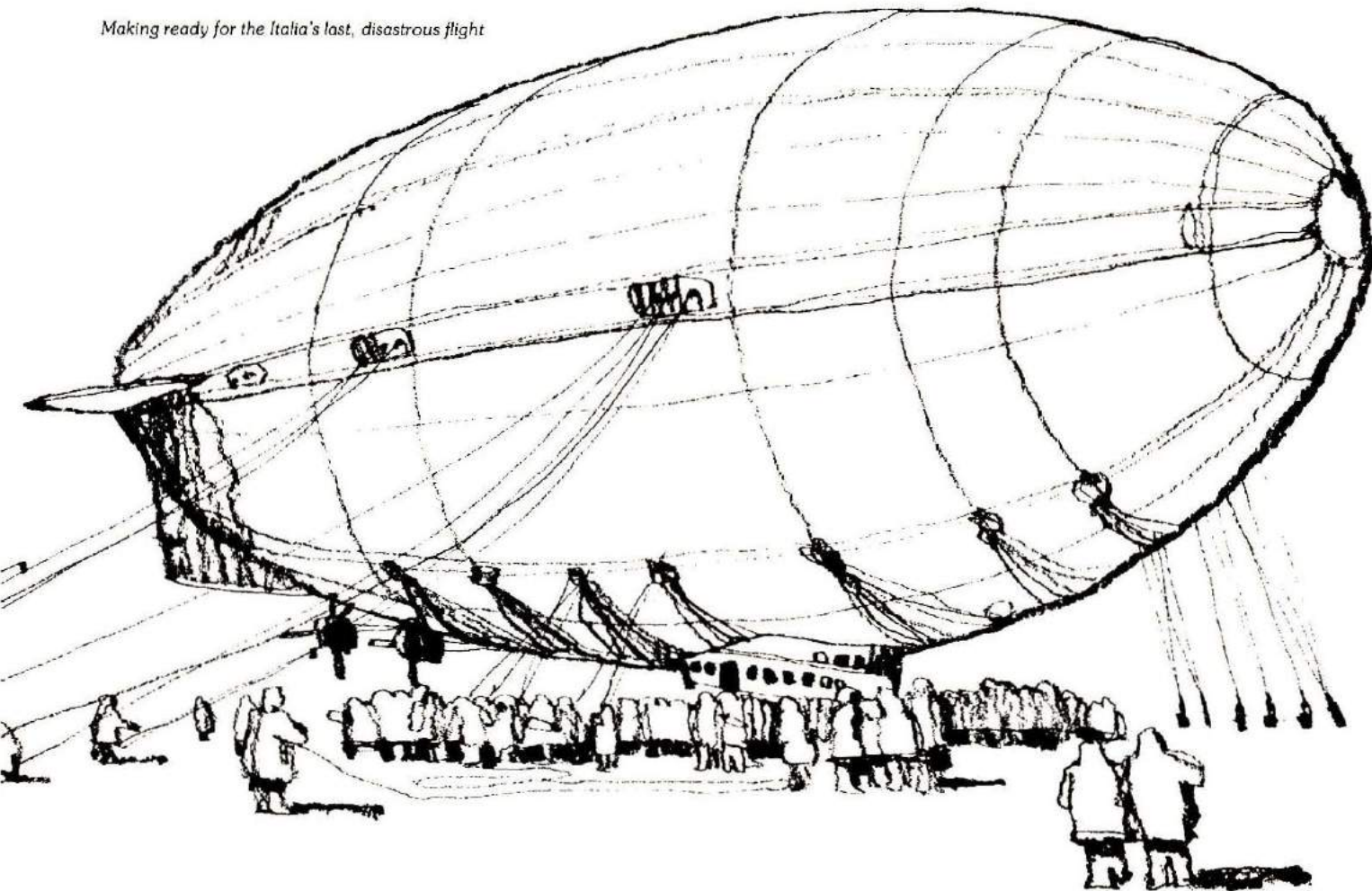

1980 US Radio Amateur Callbook

Don't be one of those who waits until the year is half over to buy a new callbook. Invest in a callbook today and get a full year's use out of your purchase. Crammed full of the latest addresses and QSL information.

You'll find:

Boldface calls, names and addresses for every licensed Amateur in the U.S.

□ CB-US Softbound \$16.95

**BOTH BOOKS
AVAILABLE NOW**

The Foreign Callbook

DXing is a real joy, but it's even better when you get back **QSL** cards from the countries you've worked. The most important tool in getting those cards is to have a copy of the **1980 Foreign Callbook** on your operating table. Stations are listed by country, call, name and address in bold, easy-to-read type. □ CB-F Softbound \$15.95
Please include \$1.75 additional shipping for each Callbook ordered.

HAM RADIO'S BOOKSTORE

GREENVILLE, N. H. 03048

(800) 258-5353

1980
1980
HANDBOOK
See page 50 for super value
on 1980 ARRL Handbook.
1980

rettes, and two huge pairs of shoes.

The *City of Milan* now cut off communications as if there was nothing to worry about. The next evening, two Swedish seaplanes located them by smoke signals. Two bottles of whiskey were dropped in red parachutes. Everyone agreed the Swedes were a practical people.

A message to tell the Swedes of a landing field on the ice did not get through. The *City of Milan* did not answer the continual calls of Biagi. Those at King's Bay did not realize the ice was breaking up from warming weather, presenting a dangerous situation.

On June 23rd the radio went dead just as contact with the *City of Milan* requested they transmit a message to the Swedes about the landing field.

The 31st day on the pack found no word from the *City of Milan*. Two planes suddenly were heard and the smoke signals guided them toward a marked off field. One plane swooped low several times, and then its skis touched the snow and skidded to a stop. There was a wild race to the plane by those who could run. The pilot was Einar Lundborg, and he requested to meet Nobile, and insisted Nobile leave with him as first off the pack. Nobile insisted the injured be first, but Lundborg demanded Nobile be first, "We need your instructions to start looking for the others." Lundborg had definite orders from the leader of the expedition to bring back Nobile. Biagi spoke up and said Nobile should go first because he could get things moving at King's Bay and then they would all be safe. Nobile left, leaving his heavy clothing but taking a picture of his daughter and two radio notebooks.

Once in the air, Nobile was able to see how hard it was to locate the camp. It blended with, and disappeared into, the arctic. Within thirty minutes they were at the advance Swedish camp. The plane returned to the pack. On the second landing it overturned. The Swedes had no other plane equipped with skis.

Nobile was flown to the *City of Milan*. When he looked in a mirror after thirty-two days of caked dirt and filth, he saw a stranger. Talking to Captain Romagna was more important than cleaning up. Why hadn't the SOS been picked up? Nobile was

shocked to learn Romagna assumed they could not transmit so it was a waste of time to listen, and he explained his theory of how Biagi's head had been chopped off. Nobile insisted the *City of Milan* operators listen regularly, and sent signed radiograms to his men to keep them properly informed. Romagna had placed Nobile under virtual arrest, contending he had orders from Rome to prevent Nobile from taking part in any rescue expedition. Romagna refused permission for the Italian hydroplane to use the Swedish base, which was two hundred miles closer to the pack. He sent word to the men on the floe that the Russian ice-cutter *Krassin* would reach them in about two days. Nobile was furious, and sent word of the fact that the cutter was in Virgo Bay and would not arrive for more than a week. The Swedes flew in and took Lundborg, their downed pilot, from the ice.

Tragedy was begetting tragedy. Amundsen was lost; the Russian aviator, Babushkin, failed to return; alpinists Sora and Van Dongen, with dog teams, had not been heard from. All were lost and never located.

The *Krassin* became the only hope, with sudden bad weather. The ship had a damaged helm and broken propeller, but continued east. They found the three men who had set out on foot, and knew they must be near the floe.

After all this time, Biagi became sick and the radio could not be used to its full extent. The *Krassin* broke through the ice pack, and later that evening spotted the overturned plane. The ship's whistle blew and the five remaining men on the floe sent up smoke signals. Their forty-nine days of cold and hunger were at an end. Giuseppe Biagi, radio operator, sent his final message from the ice pack ending with, "Greetings to our beloved General Nobile." And would Biagi go back to the arctic? "With the general, yes," said Biagi.

So Giuseppe Biagi returned to Italy. He had held to the fine thread of hope that his steady CW would be heard from the arctic wilderness. He would not quit, and he was there when many needed him. He is not remembered as a hero, but then, too, not all heroes wear medals.

HRH

KITTY SAYS: "MAY Is Antenna Month here at Barry Electronics. Call today and ask about our specials on rotors, towers, beams, verticals, coax, and accessories . . . Barry has 'em all. By the way, have you tried the new MURCH five-band dipole antenna with the companion transmatch? This is a way to cover the world at minimum cost! Remember, too, that we're just now coming into mobile season, and that means we will have *specials* on mobile transceivers — both VHF and HF — that you can't beat! I'd like to show you the New YAESU *Wayfarer* for HF, or the FT-207R for VHF, and many of our other rigs. How about it? . . ." Kitty, WA2BAP.

We have:

- ANTENNAS FOR HF & UHF
- ROTORS
- TOWERS
- REPEATERS
- MICROPHONES
- KEYS & KEYERS
- TUBES and much, more

We Also Stock . . .

- AEA
- ANTENNA SPECIALISTS
- B & W
- BIRD
- COMMUNICATIONS SPECIALISTS

- COLLINS
- CUSHCRAFT
- DSI
- DENTRON
- DRAKE
- EIMAC
- E-Z WAY
- HY-GAIN
- ICOM

- KDK
- KLM
- MFJ
- MIRAGE
- MOSLEY
- MURCH
- NEWTRONICS
- ROBOT
- ROHN

- SHURE
- STANDARD
- SWAN
- TEMPO
- TEN-TEC
- TRI-EX
- VHF
- ENGINEERING

JUST CALL OR WRITE FOR THE BARRY PRICE: BETTER STILL . . . STOP IN!!

¡ AQUÍ SE HABLA ESPAÑOL !

ASK ABOUT OUR  LICENSE CLASSES: Wed. & Thurs. 7 - 9 PM Saturday 10 - noon

The Export Experts Invite Overseas orders — We Ship Worldwide

BARRY ELECTRONICS 512 BROADWAY, NEW YORK, N.Y. 10012 TELEPHONE (212) 925-7000

The antenna with a big difference... the five band trap vertical Hustler 5-BTV™

The 5-BTV is made heavier for better performance and quality. Heavier traps assure accurate and permanent trap resonance. Solid one-inch fiberglass trap forms give optimum electrical and mechanical stability.

One setting provides total band coverage from 40 through 10 meters. SWR is 1.6 or better at the band edges.

The 5-BTV is top loaded at 80 meters (tuneable to 75 meters). This means greater bandwidth and lower angle of radiation.

Easy to assemble and install, the 5-BTV features 1 1/4" high strength aluminum construction. And an extra-heavy bracket with low loss-high strength insulators. Feed with any length 50 ohm coax.

For the big difference in performance, it's the Hustler 5-BTV antenna.

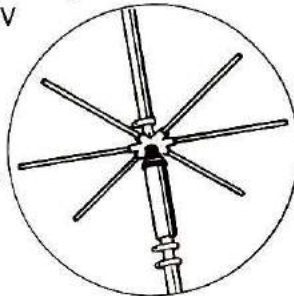

3275 North B. Ave. • Kissimmee, Florida 32741

Clearly the choice of those who know quality.



DEALERS

Electronics, Inc.
227 North Santa Fe
Salina, KS 67401
913-827-7377

Thomas Communications
95 Kitts Lane
Newington, CT 06111
203-666-6225

Broadcast Systems Co.
5840 Osuna Road, N.E.
Albuquerque, NM 87109
505-884-8235

Ham Radio Outlet
2620 West La Palma
Anaheim, CA 92801
714-761-3033
WATS 1-800-854-6046

N&G Distributing
7285 Northwest 12th St.
Miami, FL 33126
305-592-9685

Delaware Amateur Supply
71 Meadow Road
New Castle, DE 19720
302-328-7728

Easy etching process you can use to save time and learn a new skill.

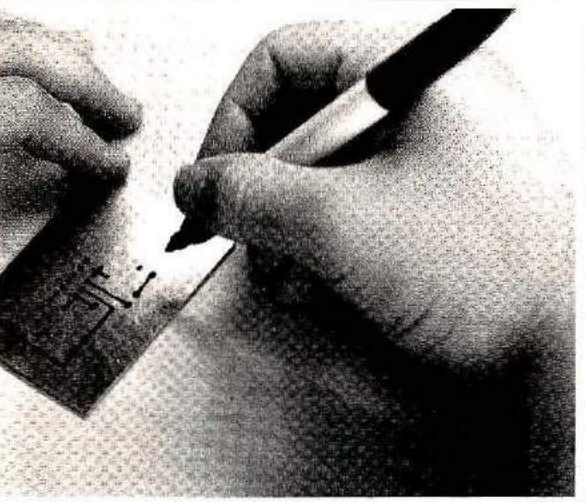

A: "Tools of the trade" used in PC-board etching: copper boards, etch-resistant lacquer, resist pen and decals, fine steel wool for cleaning the boards, and etchant.

B: A copper board surrounded by three resist methods: brush-applied lacquer, the resist pen, and resist decals.

C: The decal method of resist.

D: The pen method of resist.

E: The brush-on lacquer resist.

F: The etching process. Etching solution should completely cover the boards.

G: Agitating the plastic container speeds the etching process.

H: The finished board, ready for drilling and assembly.

Styrofoam of the same size as the board to be etched, the builder should lay out the components in an arrangement which will result in the smallest number of connections between them, hence the least cluttered circuit layout. The beginner will probably want to work with a large circuit board, allowing plenty of room for the parts. Densely etched circuit boards, like those found in transistor radios, are difficult to etch and solder.

To simplify the job of designing the actual circuit pattern, the builder can work at first on a large-scale drawing, transferring the pattern to a life-size drawing when the plan is finished. After a final check to make sure that

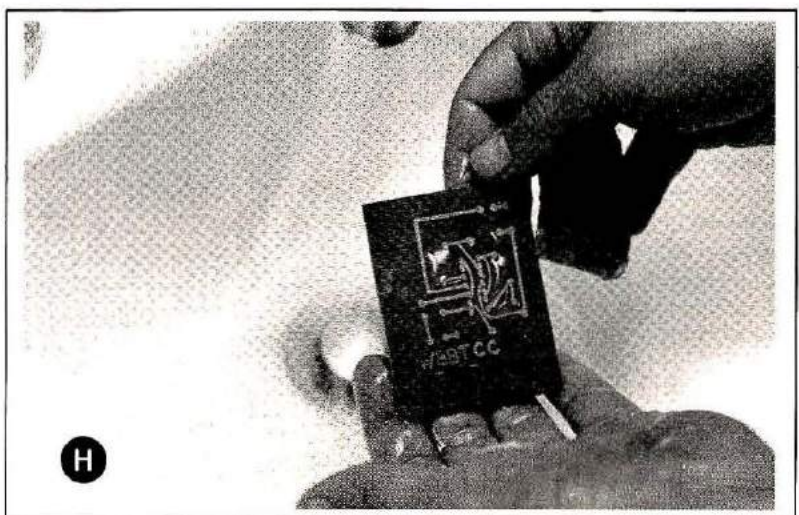
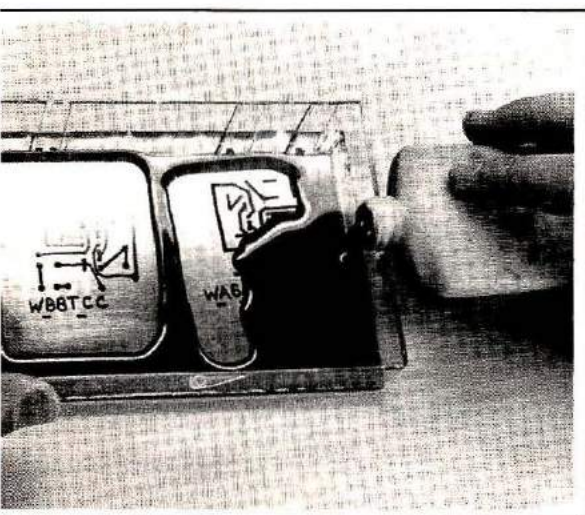
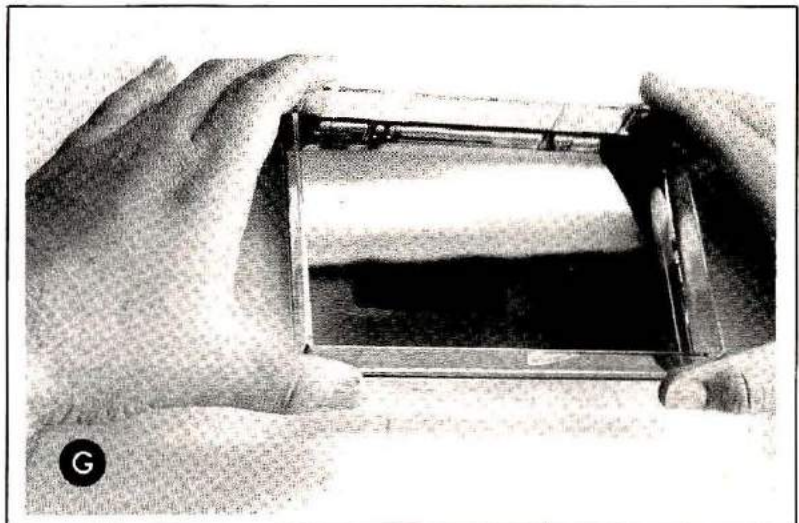
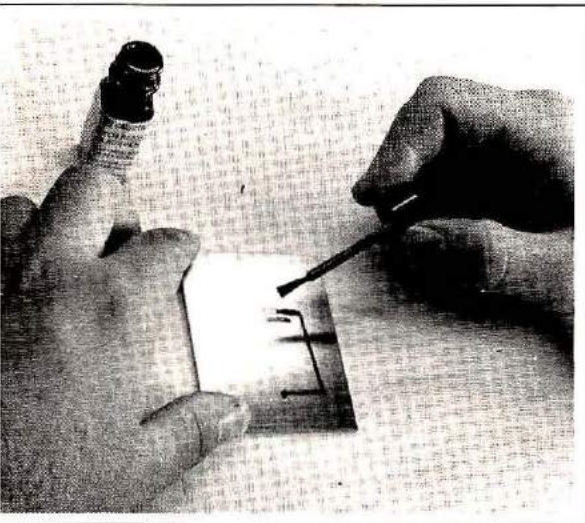

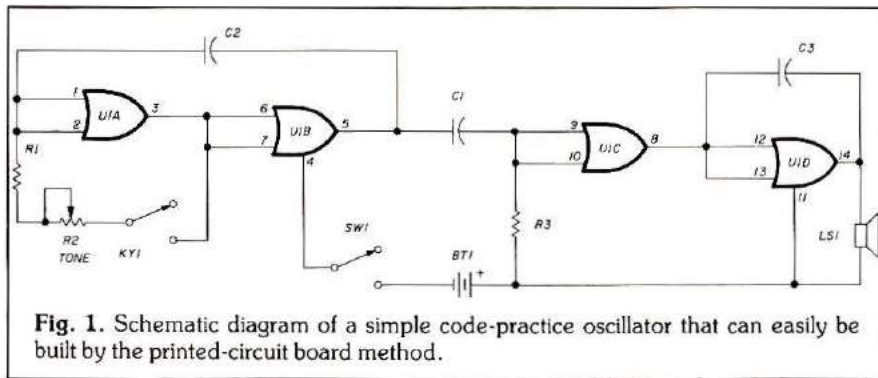

the circuit pattern corresponds to the schematic drawing of the project, the board can be prepared for etching.

Applying the resist

Before the board is placed in the etching solution, it must be specially treated to protect the desired circuit pattern. This "resist," as it is usually called, most often takes one of three forms when used by the beginner: a brushed-on lacquer, a special resistant ink which is applied with a felt pen, or pressure-sensitive strips and dots which are stuck to the board.* The resist is simply applied to the metal side of the board in the form of the desired circuit layout. When the board is etched, the chemical used will dissolve all of the metal except that which is protected by the resist material.

Before the resist is applied, the board should be washed thoroughly with soap and water, using fine steel wool to slightly scratch the board's surface. After the board has been thoroughly dried, the builder applies the resist, taking care that the layout is neat, and that none of the metal conductors will be touching where they shouldn't be. Care should be taken to ensure that the circuit has been correctly transferred to the board, and that there are no "hairline" gaps in the resist material that might allow the etchant to seep through and dissolve part of a conductor. After the board is dry (if the lacquer or pen-resist is used) it is ready to be etched.

*The pressure-sensitive strips and dots may not be practical for large projects, where very close spacing of components and connections are often required. In these cases, a litho negative should be used, along with photo-sensitive boards. This is an advanced method requiring a different approach, which we'll cover in a later issue of *Horizons*. **Editor**

Etching the board

Most beginners will use a solution of ferric chloride (available in many radio stores) to etch copper boards. The solution should be placed in a flat, shallow plastic container; the prepared circuit board is then placed in the solution, copper side up. The container should be gently agitated to keep the solution circulating over the top of the board. The etching process can be speeded up by holding the container over a low-level heat source, such as an electric light bulb, but even at room temperature the whole process shouldn't take more than twenty minutes. The board should be checked frequently, and removed from the solution as soon as it is apparent that all unprotected copper has been stripped away. If the board is allowed to over-etch, the solution may penetrate the resist, spoiling the appearance of the board, and possibly cutting entirely through a conductor.

When the board has been thoroughly etched, it should be removed from the etchant and washed for several minutes under cold running water. At this point, too, the resist can be removed. Decals usually peel off easily, and pen- or brush-applied resist will yield to a piece of fine steel wool and a little elbow grease. When the resist has been completely removed, the board should be washed one last time and then dried thoroughly with a piece of cloth or paper toweling.

A few points to remember: Etching should be done only in a well-ventilated area, and the builder should avoid prolonged contact with either the etchant or its fumes. A good pair of rubber gloves and a smock should be worn for safety. When the etching

process is completed, rinse the remaining etchant into a suitable plastic container (the solution may be used again and again until it loses its potency), and rinse all equipment with liberal amounts of running water.

Assembly techniques

The etched circuit board must be drilled before the parts are installed. Place the board, foil side up, on a block of soft wood and use a carpenter's "pin punch" to mark the location of each hole. Using a twist or electric drill with a bit just a little larger than the component leads (1/32-inch, 0.8-mm, or No. 68 drills will probably do nicely) drill the holes where the leads will enter the board.

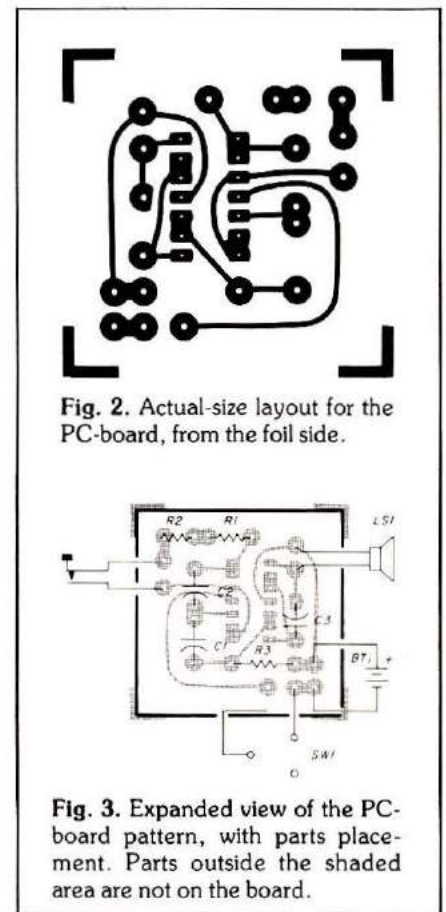

Assemble the circuit by mounting the components on the unclad side of the board with their leads projecting through the foil side. Component leads should be left uncut at first, then trimmed neatly after they have been soldered to the foil base. Soldering should be done with a low-wattage (30-40 watt) pencil-type iron, or a small soldering gun with a slim tip in-

tended for close-quarters work. Diodes and other heat-sensitive components should be protected with a heat sink if possible, and the use of a socket will avoid the risky job of trying to solder a transistor or an integrated circuit directly to the board. In all PC board soldering, avoid heating the connections any more than necessary, for too much heat may cause the foil strips to separate from the board. Also, use a minimum amount of solder, to protect against "solder bridges" that can form across adjacent conductors.

When the circuit is finished, a coat of clear lacquer will preserve its appearance and protect against corrosion.

A simple PC project

Even the most inexperienced builder can put the PC-board technique to the test by constructing a simple code-practice oscillator, and a schematic for one is shown in Fig. 1. The parts needed are as follows:

BT1	1.5-Vdc battery and holder
C1,C2	0.05 μ F
C3	0.001 μ F
KY1	Key
LS1	45-ohm intercom speaker
R1	3,900 ohm, 1/4-watt resistor
R2	10,000-ohm potentiometer
R3	10,000 ohm, 1/4-watt resistor
SW1	spt switch
U1	HEP 570 (HEP C2003P) with socket

The code practice oscillator will supply a variable-pitch tone with ample volume for small groups. By using a potentiometer with a built-in switch, SW1 and R2 can be combined into one unit. With a roomy speaker box, the entire oscillator can fit inside one enclosure.

In conclusion

PC boards, like everything else the Amateur might want to build, take a bit of practice, a bit of trial and error, and more than a bit of patience. But the payoff, as any experienced builder will testify, is more than worth the investment of time and energy. A wise Amateur will start with simple, easy-to-etch projects before moving on to the tougher ones, gaining pride in his work as he gains experience. And whether he builds a receiver, a digital voltmeter, or just a simple code-practice oscillator, he'll have the satisfaction of being able to say, "I did it myself." **HRH**

Aye!

Larsen's clan of Kūlrod® Antennas deliver top performance and value!



Performance and value are built into every Larsen Antenna because of craftsmanship that accepts no compromise.

Making mobile antennas, mounts and accessories is Larsen's *only* business. All of the company's research, engineering and production efforts are directed to making the best antennas money can buy. The end result is the exclusive Kūlrod by Larsen. A Kūlrod antenna delivers maximum radiation efficiency instead of losing power to heat.

Larsen's antenna clan includes low band, high band, quarter wave, VHF, UHF, mobile, fixed base and Kūlduckies for hand-helds. And Larsen offers every type of permanent and temporary vehicle mount — including a magnetic model that's a real grabber.

So whatever band you operate on, if your antenna is a Larsen you'll HEAR the difference!



Larsen Antennas

P.O. Box 1686
Vancouver, WA 98668
Phone: (206) 573-2722

In Canada, write to:
Canadian Larsen Electronics, Ltd.
283 E. 11th Ave., Unit 101
Vancouver, B.C. V5T 2C4
Phone: (604) 872-8517

®Kūlrod is a Registered Trademark of Larsen Electronics, Inc.
™Kūlduckie is a Trademark of Larsen Electronics, Inc.

Call
Toll Free

1-800-633-3410

IN ALABAMA CALL 1-800-292-8668 9 AM TIL 5:30 PM CST, MONDAY THRU FRIDAY



COPAL RP-205 24-hour clock with 24-hour alarm

Highly accurate with a 24-hr. alarm that can be set for either AM or PM and in 10-minute intervals. Features illuminated leaf-type numerals and precision synchronous motor.

19.95



DYNAMIC INSTRUMENTS
nickel cadmium rechargeable batteries
Never run out of batteries again.
Guaranteed for 5 years

Size AA List 7.35..... 2 for 4.33

Size C List 7.95..... 2 for 5.15

Size D List 8.25..... 2 for 5.30

9 volt List 12.95 9.50 each

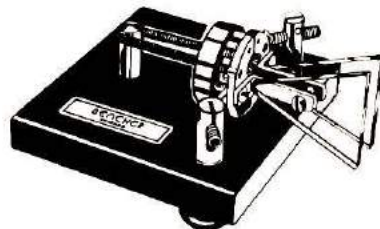

BENCHER BY-1 Iambic paddle

With solid silver contact points, full range adjustment, non-skid feet and heavy steel black-textured base.

39.95 Call today.

HY-GAIN 287 magnetic mount foldover antenna

The 287 with unique foldover design has 5/8 wave for low angle radiation. Adjustable thru a 180 degree arc and withstands speeds up to 120 mph. Less than 1.4:1 VSWR, 144-148 MHz, power rated to 150 W, 3 dB gain, DC grounded.

19.95 Call today.

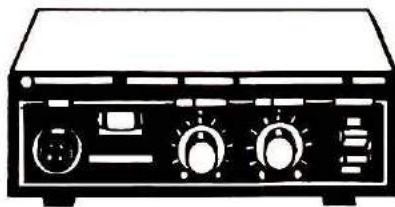

KENWOOD PC-1 phone patch

The PC-1 features NULL control, RX and TX gain controls and VU meter. Connects between a transceiver and a phonenumber.

59.95 Call today.

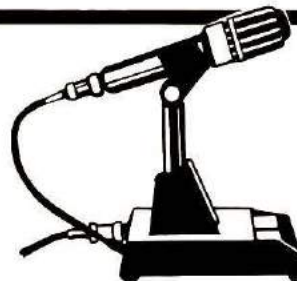

KENWOOD MC-50 dynamic desk mic

The MC-50 features dual impedance, 500 ohms or 50K ohms. Compatible with Kenwood equipment.

45.00 Call today.

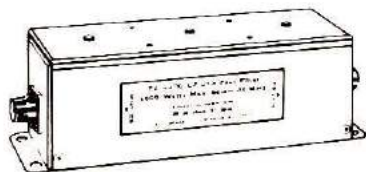

DRAKE TV-3300-LP low pass filter

Low pass filters, properly attached to transmitters attenuate all harmonics falling in any TV channel or the FM band. 1000W max. below 30 MHz. Attenuation better than 80dB above 41 MHz.

26.60 Call today.



SHARP CB-2460 40-channel CB transceiver

A full featured 40-channel CB with RF/signal meter, channel 9 priority monitor with LED readout, detachable mic with PTT switch, PA operation optional. Also delta tuning, squelch control and automatic noise limiter.

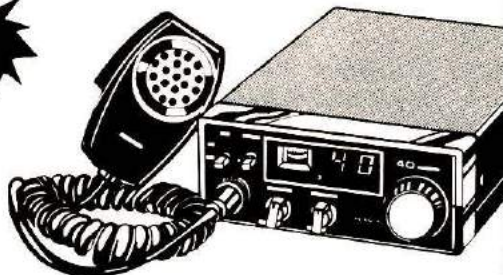

49.95 List Price 139.95



B & W 595 coax switch

Features 6 outputs, a power rating of 2 KW PEP and VSWR of less than 1.2:1 up to 150 MHz. Grounds all unused antennas.

21.50 Call today.



TELEX Audio Fax 610 headphones

Shock and moisture resistant with easy adjustment for fit and comfort. Snap-fit plug-in cord. Impedance - 600 ohms.

6.32



MFJ-941B Versa tuner II

Has SWR and dual range wattmeter, antenna switch, built-in balun and 300W RF output. Has SO-239 connectors and mobile mounting bracket.

79.95 Call today.

Testing Semiconductors with a VOM

BY SAM GUCCIONE, K3BY

Would you believe that, using a standard VOM (volt-ohm-ammeter), a 100-ohm resistor, and a 1.5-volt flashlight battery, a quick GO/NO-GO test can be performed on many semiconductor devices? It's true, and **Tables 1 through 5** show the test set-up and dc resistance response for more than a dozen semi-conductor devices.

Almost any standard type of VOM, except the digital models, may be used. However, one caution should be observed: The VOM is used as an ohmmeter in these tests, and a battery is needed in the ohmmeter circuit, to polarize the test leads. Thus, one lead is defined as positive and the other, of course, negative. In the popular Simpson 260 meter, the "COM" jack is the negative lead and the "V/A" jack is the positive lead. On the other hand, in the Micronta 22-203 VOM, the "COM" jack is the positive lead and the "VΩA" jack is the negative lead.

It's easy to determine the polarity of your VOM. Obtain a good semi-conductor diode, and identify the banded, or cathode, end. Set the ohmmeter to the R times 1 ($R \times 1$) or the R times 10 ($R \times 10$) range. Then, connect the lead from the "COM" jack to the cathode end of the diode, and connect the other lead to the anode end of the diode. If the meter goes to a low resistance reading, then the "COM" jack of your meter is truly negative and the other jack is positive. If the meter does not move or indicates a very high resistance, reverse the leads. The meter should show a low resistance. Now the "COM" jack of your meter is connected to the anode, and the other to the cathode. The lead connected to the anode is the positive lead, and the lead connected to the cathode is the negative lead.

Now that you have your VOM leads properly identified, you are ready to begin testing. Whenever a 1.5-volt cell is required, any size from A to D will do.

Let's look at some of the tests in the **Tables**. Your VOM should be set on the $R \times 1$ or $R \times 10$ range. **Table 1** shows the tests for seven diodes.

Since many of the other devices are essentially diodes in one form or another, the semi-conductor diode is listed first because it is the easiest to test. The meter-indication column contains the expected meter indication for a good device. For example, when the VOM is connected as shown in (a) under the Test Set-Up column,

a good diode will show a low resistance (on the $R \times 1$ or $R \times 10$ range) but not zero. If the indication is zero ohms, the diode is shorted.

Then, reversing the VOM as in (b) will produce a high resistance (on the $R \times 1$ or $R \times 10$ range), but not infinite ohms. If the indication is infinite, then the diode is open.

TABLE 1 DIODE TESTS









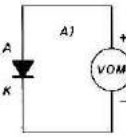
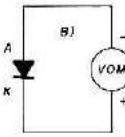

DEVICE	TEST SET UP	METER INDICATION
DIODE (A) ANODE  (K) CATHODE	 	A) LOW B) HIGH
DIAC 	 	A) HIGH B) HIGH
LED (A) ANODE  LIGHT (K) CATHODE	 	A) LIGHT FROM LED B) NO LIGHT FROM LED
SCHOTTKY BARRIER AND MICROWAVE	CAN NOT TEST BY THIS METHOD	NONE
TUNNEL DIODE (A) ANODE  (K) CATHODE	 	A) LOW B) HIGH
VARICAP OR VARACTOR (A) ANODE  (K) CATHODE	 	A) LOW B) HIGH
ZENER (A) ANODE  (K) CATHODE	 	A) HIGH B) LOW

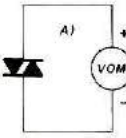
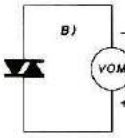
Table 1. Diode tests.

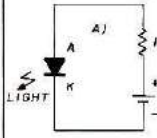
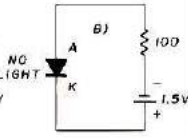
TABLE 2 BIPOLAR JUNCTION TRANSISTOR TESTS

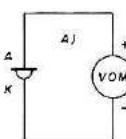
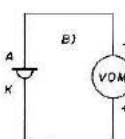
DEVICE	TEST SET UP	METER INDICATION
BJT - NPN 		A) LOW
		B) LOW
		C) HIGH
		D) HIGH
BJT - PNP 		A) LOW
		B) LOW
		C) HIGH
		D) HIGH

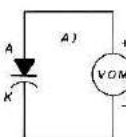
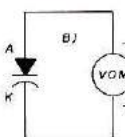
Table 2. Bipolar junction transistor tests.

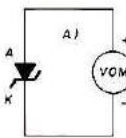
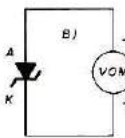
The DIAC, or bidirectional trigger diode, requires a fairly high voltage to make it work. An ohmmeter cannot supply a large enough voltage to test the DIAC. The LED, light emitting diode, is tested by simply applying 1.5 volts to the diode. The 100-ohm resistor is absolutely necessary, or the diode will be burned out because of high current. If the LED does not show visible light with the battery connected either way, it is bad and should be thrown away.

Special high frequency diodes such as the PIN, Schottky, and microwave types should not be tested using a VOM. These diodes will be damaged by the voltages present in this hookup.

The last three diodes in Table 1 can be tested as regular diodes. However, this dc test will not measure the special characteristics of each of these diodes. A curve tracer or other such device must be used. This simple dc test will merely show whether the device is burned out.

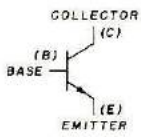
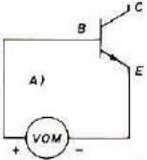
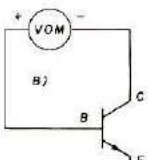
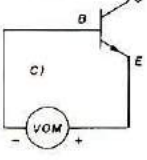
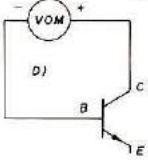
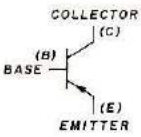
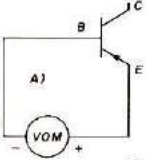
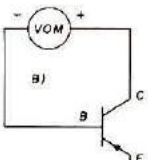
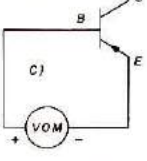
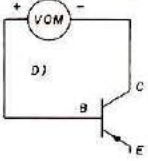
Table 2 shows the NPN and PNP bipolar transistor. The NPN and PNP transistors are essentially diodes connected end-to-end so that the test consists of testing two diodes. Connections at (a) and (c) are for the

base-emitter diode, and (b) and (d) are the tests for the base-collector diode.

The junction field-effect transistor (jfet) requires 1.5 to 4.5 volts to see if it is working. Notice the polarity of the battery: A negative voltage is required on the gate of an N-Channel jfet to cause it to have a high resistance between drain and source. The gate must be connected to the source to get a low-resistance indication. A word of caution about some fets: the metal oxide semi-conductor fet (mosfet) should not be tested using this method. The mosfet is extremely susceptible to voltage transients, such as static discharges. Thus, more than likely, a mosfet will be burned out by testing using a VOM and battery. Table 3 shows the two types of mosfets: the DE (depletion-enhancement) and E (enhancement). Mosfets are sometimes called igfets, which stands for insulated gate field-effect transistors.

Table 4 shows three devices which I call three-lead switching devices. The first one is the SCR, or silicon controlled rectifier. The SCR latches when voltage is applied to the gate; the meter indication is high until the

TOROID CORES



- ✓ All the popular sizes and mixes.
- ✓ Fast Service. Same day shipment via first class mail or air.
- ✓ No minimum order.

IRON POWDER TOROIDS:

CORE SIZE	MIX 2 5-30 MHz u = 10	MIX 6 10-90 MHz u = 8.5	MIX 12 60-200 MHz u = 4	SIZE OD (in.)	PRICE USA \$
T-200	120			2.00	3.25
T-106	135			1.06	1.50
T-80	55	45		.80	.80
T-68	57	47	21	.68	.65
T-50	51	40	18	.50	.55
T-25	34	27	12	.25	.40

RF FERRITE TOROIDS:

CORE SIZE	MIX Q1 u = 125 1-70 MHz	MIX Q2 u = 40 10-150 MHz	SIZE OD (in.)	PRICE USA \$
F-240	1300	400	2.40	6.00
F-125	900	300	1.25	3.00
F-87	600	190	.87	2.05
F-50	500	190	.50	1.25
F-37	400	140	.37	1.25
F-23	190	60	.23	1.10

Chart shows uH per 100 turns.

FERRITE BEADS:

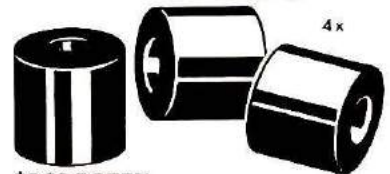

\$2.00 DOZEN

WIDE BAND CHOKES

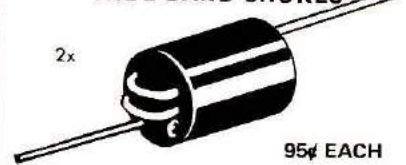

95¢ EACH

TO ORDER: Specify both core size and mix for toroids. Packing and shipping 50 cents per order USA and Canada. Californians add 6% sales tax.

Fast service. Free brochure and winding chart on request.

PALOMAR ENGINEERS

BOX 455, ESCONDIDO, CA 92025
Phone: (714) 747-3343

NEWCOMER OR OLD PRO ...
ALPHA POWER
 IS YOUR KEY TO A
BIG SIGNAL

ALPHA/VOMAX can boost the "talk power" of any rig up to ten times or more. The new SBP-4 split band speech processor uses the only system more effective than rt clipping — AND distortion is extremely low so your voice sounds natural. Under tough conditions VOMAX can help as much as most linears. Combine VOMAX with a good linear and WOW! It's simple to install and operate with any rig.



ALPHA 374A is a heavy-duty "rock crusher" ... a full kilowatt (2+KW PEP), No Time Limit, all band, NO TUNE UP desk top linear amplifier. It's a no-compromise ALPHA with a TWO YEAR FACTORY WARRANTY.

Other superb ALPHA s include the "Ultimate LINEAR" ALPHA 77Dx and the new ALPHA 78, which combines NO-TUNE-UP maximum legal power, No Time Limit, and high speed (vacuum relay) CW break-in. Call or write your dealer or ETO direct for illustrated literature on all ALPHA products.



EHRHORN TECHNOLOGICAL
 OPERATIONS, INC.
 P.O. BOX 708, CANON CITY, CO 81212
 (303) 275-1613



July 26 thru August 8, 1980

Our 21st year of successful teaching

**Boost your Ham Skills
 on the Blue Ridge**

"A Vacation with a Purpose"

Two weeks saturation learning program in Amateur Radio:

- Novice to General
- General or Technician to Advanced
- Advanced to Amateur Extra

Expert Instruction starting at your level. Code and Theory in depth along with Friendly Amateurs, Who Care About You.

C. L. PETERS, K4DNJ, Director
 Oak Hill Academy Amateur Radio Session
 Mouth of Wilson, Virginia 24363

Name _____ Call _____
 Address _____
 City/State/Zip _____

TABLE 3 FIELD EFFECT TRANSISTOR TESTS

DEVICE	TEST SET UP	METER INDICATION
JFET - N CHANNEL	A) 	A) LOW
	B) 	B) HIGH
JFET - P CHANNEL	A) 	A) LOW
	B) 	B) HIGH
MOSFET	 SHOULD NOT BE TESTED BY THIS METHOD	NONE

Table 3. Field effect transistor tests.

battery is momentarily connected to the gate, then the meter goes low and stays low even with the battery disconnected. The battery should not be connected to the gate without the resistor.

The TRIAC, or triode ac switch, is identical to the SCR except that the VOM can be connected to MT2 or MT1 either way.

The UJT (unijunction transistor) is included here, instead of in Table 2, since it is used almost exclusively as a switching device. The UJT is tested in the same way as the SCR, but it does not latch like an SCR; that is, the meter will read low only when the battery is connected.

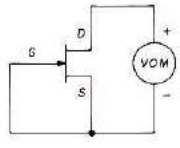
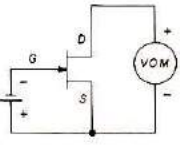
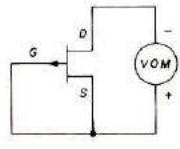
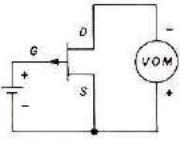
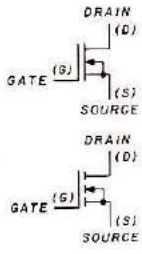
By adding appropriate impurities, manufacturers can cause semi-conductor material to have a resistance

that varies in a special way. Table 5 contains three popular devices. The first is a light dependent resistor (LDR), or photocell. It can be thought of as a light-sensitive resistor. The more light that shines on the photocell, the lower its resistance.

A thermistor is a thermally sensitive resistor. The resistance will vary depending upon the type of thermistor. Some are negative-temperature-coefficient thermistors, which means the resistance increases with increasing temperature. The VOM should show some measurable value. When the thermistor is heated, the resistance should change.

The last item in Table 5 is the voltage-dependent resistor (VDR), or varistor. The resistance of a varistor changes with the voltage applied to it.

TABLE 4 THREE-LEAD SWITCHING DEVICES

DEVICE	TEST SET UP	METER INDICATION
<p>SCR</p> 	<p>CONNECT 1.5V BATTERY TO GATE (POSITION B) MOMENTARILY UNTIL METER GOES LOW</p> 	<p>A) HIGH</p> <p>B) METER WILL GO LOW AND STAY LOW EVEN WITH BATTERY DISCONNECTED</p>
<p>TRIAC</p> 		<p>A) HIGH</p> <p>B) METER WILL GO LOW AND STAY LOW EVEN WITH BATTERY DISCONNECTED</p>
<p>UJT</p> 		<p>A) HIGH</p> <p>B) METER WILL GO LOW ONLY WHEN BATTERY IS HELD CONNECTED TO EMITTER</p>

Table 4. Tests for three-lead switching devices.

TABLE 5 TESTING SEMICONDUCTOR RESISTANCES



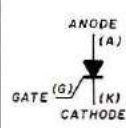
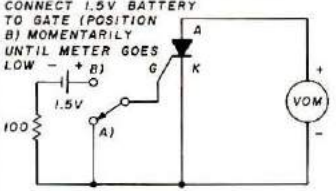
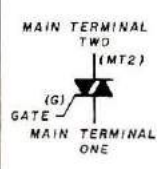
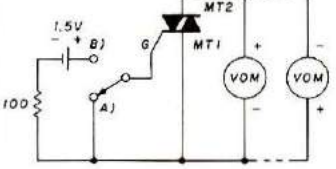
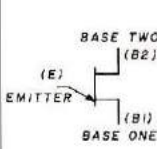
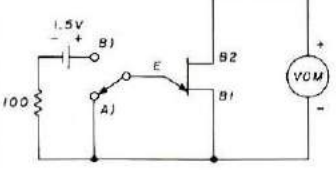

DEVICE	TEST SET UP	METER INDICATION
<p>PHOTO CELL OR LDR</p> 		<p>A) HIGH WITH NO LIGHT SHINING ON PHOTOCELL</p> <p>B) LOW WITH LIGHT SHINING ON PHOTOCELL</p>
<p>THERMISTOR</p> 		<p>A) METER WILL HAVE MEASURABLE VALUE IF THERMISTOR IS GOOD</p>
<p>VARISTOR OR VDR</p> 	<p>CAN NOT BE TESTED BY THIS METHOD</p>	<p>NONE</p>

Table 5. Testing semi-conductor resistances.

A varistor cannot be checked with an ohmmeter.

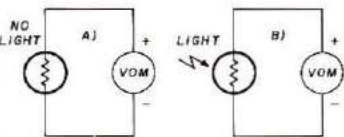
The preceding tables contain simple dc tests for eighteen popular semiconductor devices, which should include the most common types you are likely to find in use today. In addition to making it possible to troubleshoot defective gear, these tests will

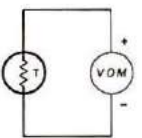
enable you to sort through that bargain-priced bagful of goodies that you bought at the flea market or through a mail-order firm. It might be a good idea to make copies of the Tables, and hang them near your test setup or workbench for ready reference when you need the information in a hurry.

HRH

When it comes to
**AMATEUR
RADIO QSL's...**

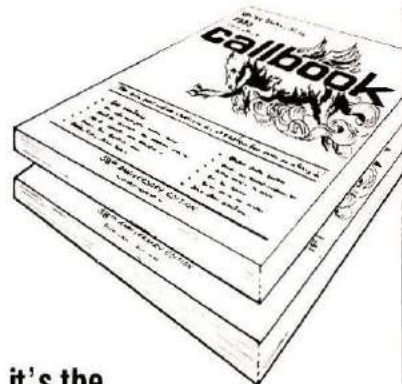

it's the
ONLY BOOK!
US or DX Listings

**1980
callbooks**
NOW READY!

Here they are! The latest editions. World-famous Radio Amateur Callbooks, the most respected and complete listing of radio amateurs. Lists calls, license classes, address information. Loaded with special features such as call changes, prefixes of the world, standard time charts, world-wide QSL bureaus and more. The new 1980 Radio Amateur Callbooks are available now. The U.S. Edition features over 400,000 listings, over 120,000 changes from last year. The Foreign Edition, over 315,000 listings, over 90,000 call changes. Place your order now.

	Each	Shipping	Total
<input type="checkbox"/> US Callbook	\$16.95	\$1.75	\$18.70
<input type="checkbox"/> Foreign Callbook	\$15.95	\$1.75	\$17.70

Order both books at the same time for \$34.65, includes shipping.

Order from your favorite electronics dealer or direct from the publisher. All direct orders add \$1.75 for shipping. Illinois residents add 5% Sales Tax.



SPECIAL LIMITED OFFER!
**Amateur Radio
Emblem Patch**
only \$2.50 postpaid

Pegasus on blue field, red lettering. 3" wide x 3" high. Great on jackets and caps. Sorry, no call letters.

ORDER TODAY!

RADIO AMATEUR
callbook INC.
Dept. EB 2
925 Sherwood Drive
Lake Bluff, IL 60044



IC Keyer

The World's Greatest Sending Device



Adjustable to Any Desired Speed

Now available from Palomar Engineers — the new Electronic IC KEYER. Highly prized by professional operators because it is **EASIER, QUICKER, and MORE ACCURATE.**

It transmits with amazing ease **CLEAR, CLEAN-CUT** signals at any desired speed. Saves the arm. Prevents cramp, and enables anyone to send with the skill of an expert.

SPECIAL RADIO MODEL

Equipped with large specially constructed contact points. Keys any amateur transmitter with ease. Sends Manual, Semi-Automatic, Full Automatic, Dot Memory, Dash Memory, Squeeze, and iambic — **MORE FEATURES** than any other keyer. Has built-in sidetone, speaker, speed and volume controls, **BATTERY OPERATED**, heavy shielded die-cast metal case. Fully **ADJUSTABLE CONTACT SPACING AND PADDLE TENSION.** The perfect paddle touch will **AMAZE** you.

Every amateur and licensed operator should know how to send with the IC KEYER. **EASY TO LEARN.** Sent anywhere on receipt of price. Free brochure sent on request.



Send check or money order. **IC KEYER \$117.50** in U.S. and Canada. Add \$4.00 shipping/handling. Add sales tax in California.

Fully guaranteed by the world's oldest manufacturer of electronic keys. **ORDER YOURS NOW!**

Palomar Engineers

Box 455, Escondido, CA. 92025 • Phone: [714] 747-3343



Bind 'em and Find 'em

Keep those valuable issues of both Ham Radio and HORIZONS like new. Prevent smears, tears and dog ears. Bind 'em together and enjoy for years to come. You'll be happy you did!

★ ★ ★

HAM RADIO BINDERS

Beautiful buckram binders complete with date labels. Available in our new large size to accommodate HAM RADIO'S hefty issues.

HR-BDL Each Just \$6.95
3 for \$17.95

HAM RADIO MAGAZINE FILES

Your collection of HAM RADIO Magazines is a valuable resource. Here's a brand new, inexpensive way to store them. These sturdy cardboard magazine files keep them clean, neat and up front where you can use them for quick and easy reference.

HR-HRMF \$1.95 each
3 for \$4.95

HAM RADIO HORIZONS BINDERS

Handsome washable binders complete with date labels.

HR-HRDL Each Just \$6.95
3 for \$17.95

HORIZONS MAGAZINE FILES

Your collection of Ham Radio HORIZONS is a valuable resource. Here's a brand new, inexpensive way to store them. These sturdy cardboard magazine files keep them clean, neat and up front where you can use them for quick and easy reference.

HR-HRHF \$1.95 each
3 for \$4.95

ORDER TODAY

Ham Radio's Bookstore
GREENVILLE, NEW HAMPSHIRE 03048

OR CALL TOLL FREE
1 (800) 258-5353

BINDERS

HR-BDL \$6.95 ea. HR-HRMF \$1.95 ea.
 HR-HRDL 3/\$17.95 HR-HRHF 3/\$4.95

CASH CHARGE MC VISA
Exp. _____

Card Number _____

Name _____

Address _____

City _____

State _____ Zip _____

Ham Radio Techniques

BY BILL ORR, W6SAI

I'll tell you something: the authors who write for *Ham Radio Horizons* and *ham radio* certainly get quick feedback from their readers. I wrote an article on linear amplifier design and construction that appeared in the June, 1979, issue of *ham radio*. There was a mention in that article of the hazards of buying surplus or second-hand transmitting tubes from unknown sources, and I made the suggestion that you would be better off buying new tubes having a factory warranty.

One of the readers, William Brain (K5BEY, Houston, Texas), was quick to write me, pointing out that he'd had a lot of luck with a simple high-frequency kilowatt linear amplifier using surplus 813 transmitting tubes that he'd picked up at a flea market, at prices ranging from two bits to two dollars. Furthermore, the amplifier was built using information given in one of my older handbooks.¹

Following the publication of his letter in *ham radio*, I soon got a batch of follow-up letters from other readers who were eager to build an 813 linear amplifier using surplus tubes that are gathering dust in their junk collections.

The handbook in which the article appeared is now out of print, and so I am presenting the following revised and updated version of the circuit that has proven so popular over the years.

Inexpensive 813 Linear Amplifier

"Inexpensive" is a relative word. If you buy new 813s today, you'll pay over \$56 apiece. But you can pick up surplus 813s at a flea market or ham-swap for a few dollars. I'll give you some tips on picking out good tubes later. Right now, let's assume you

have the tubes at hand and want to build an amplifier around them.

A pair of triode-connected, cathode driven (grounded grid) 813s will comfortably run 1000 watts PEP input for sideband service, and about 800 watts for CW operation. Key-down plate voltage should be between 2000 and 2700 volts, with peak plate current of 400 to 500 mA. If power input is excessive, the tube anodes will run red and signal you to back off a bit. Peak drive power is about 60 watts in either mode. Efficiency is about 60 per cent, and third-order distortion products are better than 30 dB below one tone of a two-tone test signal at maximum input power.*

The basic amplifier circuit (Fig. 1) uses an untuned cathode input circuit for simplicity. This cost-cutting scheme works well with exciters using vacuum tubes in the output stage, but may present loading problems for the solid-state, untuned-output transceivers which are rapidly gaining popularity. A tuned input circuit which can be an add-on feature to the amplifier solves this problem (Fig. 2).

For simplicity, the amplifier is designed for single-band operation, and plate-circuit design for the various high-frequency bands is shown in Fig. 3. Those Amateurs wishing to make a bandswitching amplifier are referred to the new *Radio Handbook*² for additional details.

The circuit is a true grounded-grid

*For some reason the ARRL rates the two-tone test as the ratio of the two-tone signal to the peak input power. This is not the industry standard. This unorthodox rating makes the amplifier under test look 6 dB "better" than it actually is. Very confusing.

configuration with both grid and screen, as well as the beam-forming element of the 813 (pin 5), at ground potential. Operating bias is derived from a Zener diode in the cathode circuit. Standby bias is achieved by a 10,000-ohm resistor in the circuit return, which is shorted out for transmission by the VOX control circuitry of the exciter. Metering of grid and plate currents is also done in the filament-return circuit.

The plate is a basic pi-network with a Q of 12. This is high enough to provide adequate harmonic suppression on all Amateur bands. If the amplifier is properly shielded and built in a workmanlike manner, the second harmonic will be down over 35 dB from the fundamental signal. Additional harmonic suppression that might be required (especially on 10 meters) can be gained by the use of a low-pass filter in the antenna feed circuit.

Plate voltage is fed to the 813s via a series-connected pair of rf chokes. RFC3 is a harmonic suppressor and also provides protection against arc-overs in the plate circuit. A home-made filament choke (RFC1) is used to further reduce component cost.

The Metering and Bias Circuit

To remove high voltage from the plate-current meter, it is placed in the B-minus return to the power supply. The grid-current meter is between the filament circuit and the grids (ground). A simplified metering circuit is shown in Fig. 4.

Operating bias is determined by the Zener diode, CR1. Bias value depends to some extent upon the plate voltage, and should be determined by experiment. The "Zener" diode is made up of a number of reverse-connected power diodes, and uses the forward-voltage drop, which is about 0.7 to 1.2 volts, depending upon the current through the diode and the size of the chip. It is convenient to mount the diodes on a small pegboard, and easy to tap the diode string to achieve the correct bias. More on this later.

Amplifier Construction

The single-band design does away with the headache of bandswitching. If you wish, the coils can be mounted in position with bolts and wing nuts for band-hopping. Some Amateurs

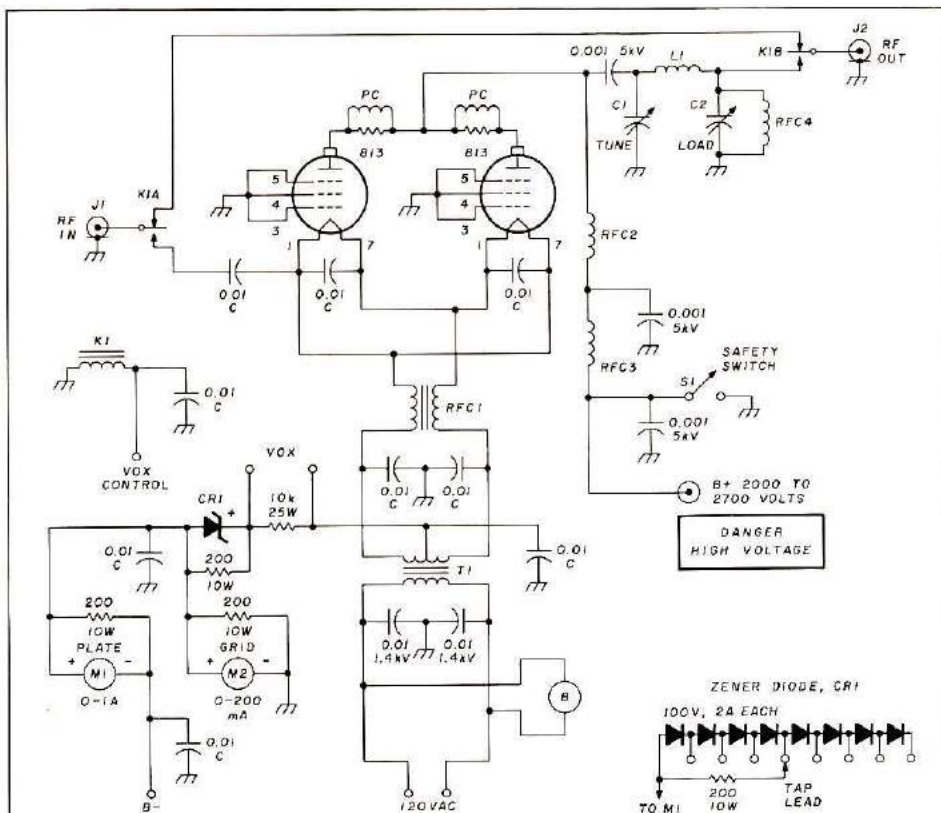

Fig. 1. Schematic diagram for 813 "grounded-grid" linear amplifier.

B Equipment cooling fan. Ripley SK-4125 or equivalent.

Values for C1, C2, and L1 are shown in Fig. 3.

M1 0-1 A dc meter

M2 0-200 mA dc meter

RFC1 Bifilar winding. Each coil is 14 turns No. 10 enamel wire on ferrite rod, 5 inches long, 1/2 inch diameter. Nick the rod at the correct length with a file and snap the excess off by hand.

RFC2 (Approx. 60 μ H) 90 turns No. 26 enamel wire, spacewound wire diameter, 3-3/8 inches long, 3/4 inch diameter on ceramic or Teflon form. Series resonant at 26 MHz. Use J.W. Miller 4535 (1.5 mH) for 160 meters.

RFC3 10 ohm, 10-watt wirewound resistor.

RFC4 2.5 mH. J.W. Miller 4528.

RY1 DPDT relay with coil to match VOX circuit voltage. Potter & Brumfield type KT antenna switching relay with glass base insulation suggested.

T1 10 volts at 10 amperes.

Disc capacitors are 0.01 μ F, 600 volts except for those on the primary of T1, which are rated at 1.4 kV. High-voltage capacitors are Centralab type 850 rated at 5 kV. Voltage rating of capacitor C1 is 3 kV, and of C2 is 600 volts. Coaxial receptacles are type SO-239. See Fig. 5 for drawing of safety switch, S1. Each parasitic choke (PC) is made up of 4 turns No. 16 wire spaced full length around 47-ohm, 2-watt composition resistor. The Zener diode is made up of series-connected power diodes, each 100 volts PIV, 2 ampere capacity, or better. High voltage connector is Millen 37001.

build up inexpensive amplifiers such as this for each band they use — this is not as expensive as it seems. If you eventually want to go the bandswitching route, plenty of data on switching circuits is available in the handbooks.

Amplifier construction is really quite simple if ready-made chassis hardware is used. Again, reference to

the handbooks and design data shown for other amplifiers in back issues of ham magazines is a big help. A 10 x 14 x 3 inch (25 x 35 x 7 cm) aluminum chassis with bottom plate makes a good starting point. My article on amplifier construction in the August, 1979, issue of *ham radio* should be a help along the way.

Generally speaking, the amplifier is enclosed in a cabinet made of perforated metal stock. A small cooling fan is used to pass air across the envelopes of the tubes. All power leads into the amplifier are suitably bypassed to reduce harmonic radiation. And, most important of all, all high voltage circuitry is contained within the enclosure to prevent accidental shock. Many modern-generation Amateurs have never worked with equipment voltages higher than 12 volts and too easily forget that plate voltages of the order of 2000 to 2700 volts are *lethal!* Never work inside the amplifier when high voltage is on.

Amplifier construction should be such that no high voltage points are exposed to touch, and, if the design is such that the enclosure is opened for coil changing, a safety circuit should be incorporated that grounds the high-voltage line whenever the cover is opened (Fig. 5).

Tuning the Amplifier

Before voltages are applied, the plate circuit should be resonated with the aid of a dip meter. Capacitor C2 (load) is set to near-full value, and the resonance setting of C1 (tune) logged for future use.

Plate voltage is applied, and the number of diodes in the Zener string adjusted for a resting plate current of 40 to 60 mA (not critical!). The drive signal is applied at reduced level and the tuning and loading controls adjusted for maximum power output as indicated by the forward reading of an SWR meter. Initial tuneup into a dummy load is recommended. Drive is gradually increased until 400 mA of plate current is achieved at a maximum grid current reading of 100 mA. The plate circuit is re-peaked for maximum power out. The drive signal (carrier) is now removed and voice modulation applied.

Because of the high peak-to-average power ratio of the human voice and the inertia of the meters, peak voice readings run about one-half, or less, of the fully loaded readings. In this example, peak plate current reading on voice will be about 200 mA and peak grid current reading will run about 50 mA. Under no circumstances should the peak meter readings approach the tuneup values or severe signal distortion and splatter will occur.

Using a Solid-State Exciter

Many of the newer exciters incorporate protective circuitry that reduces power input to the amplifier stages as the load SWR increases. Most circuits start their cutoff at an SWR of about 2-to-1. By the time the SWR is up to 3-to-1, power output is halved.

This particular amplifier is operated in class B mode; that is, the tubes draw plate current during half of the operating cycle. The load on the exciter, thus, varies from the loaded condition of the amplifier (which is about 135 ohms) to a very high value during the unloaded portion of the operating cycle. This is a varying load and can be incompatible with certain exciters. Don't think that this amplifier is the only one that is difficult to drive from a solid-state exciter; many of the amplifiers on the market have the same problem. And, in all cases, the cathode tuned circuit (Fig. 2) can solve the problem. With the aid of an SWR meter in the line between the exciter and the tuned circuit, the controls are adjusted for minimum SWR when the amplifier is running at full input power.

Amateurs that place an SWR meter between an exciter and a "grounded grid" amplifier will be amazed at the antics the meter goes through at various power levels. The SWR reading is a function of drive, amplifier tuning, loading, and signal level, and, unless a steady carrier is used for adjustment, it will be found nearly impossible to reduce the SWR on the drive cable, especially when voice modulation is used.

Buy A Surplus Tube?

The buyer must remember that no warranty or guarantee (other than that extended by the seller) exists on a second-hand or surplus tube. Some hams are under the impression that tubes "pulled" from a broadcast station are a good bargain. Rumor has it that the tubes are replaced after a few hundred hours regardless of the condition of the tube. Not so. Of all the broadcast stations known to the author (and he's in the tube business) none replace their tubes until they are run flat. When a tube delivers low power in a critical circuit, it is moved to a less critical one until finally it is inoperable, or nearly so. At that point it

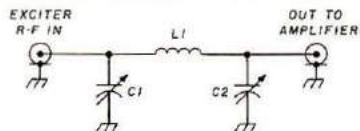

Fig. 2. Tuned cathode input circuit may be built in amplifier or auxiliary box.

Band	C1(pF)	C2(pF)	L1(μ H)	L1 — J.W. Miller coil
160	3300	2100	4.81	43A473CBI
80	1700	1130	2.59	43A333CBI
40	900	570	1.30	13 turns No. 12 enamel, 3/4 inch diameter, 1-5/8 inch long
20	440	280	0.66	7 turns No. 14 enamel, 3/4 inch diameter, 7/8 inch long
15	300	180	0.43	8 turns No. 14 enamel, 1/2 inch diameter, 1 inch long
10	220	138	0.32	7 turns No. 14 enamel, 1/2 inch diameter, 7/8 inch long

C1, C2 = Compression Mica (ARCO or J.W. Miller).
Capacitors may be paralleled to achieve larger values.

Fig. 3. Plate-circuit values for the 813 amplifier. These are computed values for a circuit Q of 12. Note that the combined output capacitance of two 813 tubes is about 28 pF. This value should be subtracted from the listed value of capacitor C1 (tune) to obtain the actual capacitor value in the circuit. In the case of the 10 and 15 meter bands, circuit Q must be increased to allow proper tuning, so two turns should be removed from the listed value of the 15 meter coil (L1) and one turn from the 10 meter coil. Once the amplifier is assembled and the tubes placed in the sockets, the plate circuit may be brought into resonance with the aid of a dip meter before the amplifier is turned on.

Band	C1(pF)	C2(pF)	L1(μ H)	L1 (Adjust with dip oscillator)
160*	354	2105	24.13	2-1/2 inch diameter, 25 turns No. 12 enamel spaced 8 turns per inch, 3 inches long
80	182	1082	12.41	2 inch diameter, 20 turns No. 10 spaced 10 turns per inch, 2 inches long
40	91	541	6.20	2 inch diameter, 11 turns No. 10 spaced 10 turns per inch, 1-1/2 inches long
20	45	271	3.10	1-1/4 inch diameter, 11 turns No. 12 spaced 1 inch long
15	30	180	2.07	10 turns 3/16 inch tubing, 1-7/8 inch diameter, 4-1/4 inches long
10	23	135	1.55	6 turns 3/16 inch tubing, 2 inch diameter, 4 inches long

*Values for center frequency of 1.8 MHz.

is discarded. "Pulls," therefore, should be avoided.

Unused surplus tubes are often available at flea markets. Here is how you can get a good idea of the quality of the tube:

1. Examine the tube. Turn it upside down and tap it. Do you see strands of wire rolling around inside the glass? If so, it probably indicates a broken filament. Hold

the tube to your ear and tap it. Do you hear any metallic, jangly noises? If you do, it may be a broken filament or grid wire.

2. Using an ohmmeter, check the filament for continuity. Check for an open circuit between the other elements, using the high-resistance scale on the ohmmeter.

3. Examine the glass for minute hairline cracks around the anode

1980 HANDBOOK

STEP INTO THE 80'S WITH THE LATEST HANDBOOK FROM THE EDITORS AT ARRL

NEW LOW PRICE!! WAS \$10, NOW JUST \$7⁹⁵

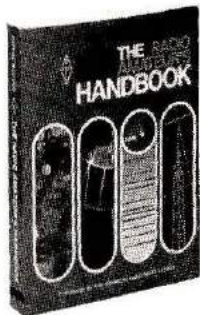

Full of exciting new features for the 80's, NOW is the time to order your copy of the 1980 ARRL "RADIO AMATEUR'S HANDBOOK." Internationally recognized and universally consulted, every Amateur should have the latest edition. The new HANDBOOK covers virtually all of the state-of-the-art developments in electronics theory and design. Novices will find it to be an indispensable study guide, while the more advanced Amateur will enjoy building the many new projects.

- Order AR-HB80 Softbound \$7.95
- Order AR-BB80 Hardbound \$15.75

HAM RADIO'S BOOKSTORE
GREENVILLE, N. H. 03048
(800) 258-5353

Ham Radio Techniques

cap and filament seals. A magnifying glass helps. Don't buy a tube that shows such a crack. Examine the glass envelope for cracks, bubbles, or blemishes.

At this stage, the tube having passed these simple examinations, you might take a chance and buy it. There are two more informative tests to be run, but these require extra equipment which you don't normally carry into a flea market.

1. Test the vacuum of the tube. You'll need a "high-pot" tester. This is a simple device which generates 20 to 30 kV at a few microamperes. The high voltage supply for a TV picture tube will do the job, or an old Ford "spark coil" will suffice. One terminal of the high-pot tester is attached to a tube filament pin and the other to the plate, or held next to the glass envelope of the tube. If the tube is "gassy" (having a minute air leak) the space between the elements of the tube will glow bright blue. The tube should be rejected.

2. This is a destructive test for a bad tube. Simply apply normal filament voltage. A good tube will glow properly. A tube with a poor vacuum will quickly fill up with a white smoke created by oxidation of the thorium layer on the filament. The tube, of course, is inoperable.

The Final Test

There's no substitute for an operational check with any power tube. Place it in the equipment and see if it works. If current measurements correspond roughly to those of a tube you know is good, your tube under test likely is good, too.

Tube testers for transmitting tubes don't exist outside the industry, and it takes considerable expertise to fully test a transmitting tube. Beware of surplus or second-hand tubes for which you hear the claim that they've been tested. After all, it is your money you are spending!

As far as surplus 813s go, the author (and also KB5EY) have had considerable success with military surplus tubes obtained either through a surplus store or in a flea market. These tubes are marked "JAN-813," indicating a joint-Army-Navy purchase and, if in the original carton, are a good risk if bought cheaply enough. You can afford to throw a junker away if the price is right. Operational data for the 813 is shown in Table 1.

Other Alternatives

Another good, inexpensive tube for grounded-grid service in a home-built amplifier is the 811A. This tube can occasionally be found surplus, but the price of a new one is not exorbitant. Four 811As in parallel can run 1000 watts PEP input for sideband service at about 1600 volts, and will run nearly 800 watts CW at the same plate

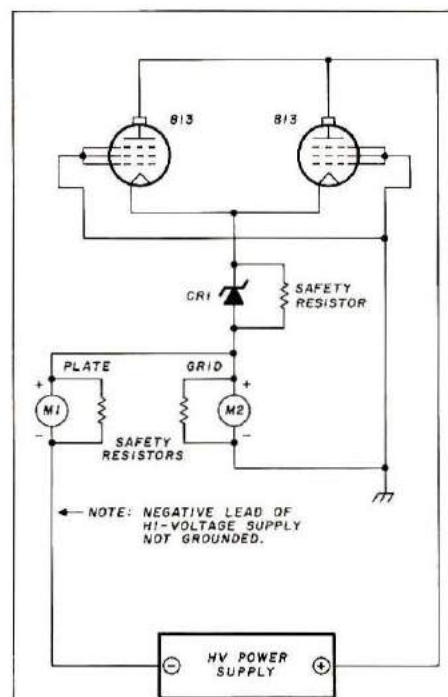

Fig. 4. Dc metering circuit for the 813 amplifier. The rf and dc ground are at the screen and grid elements of the tubes. Metering is inserted in the supply return leads to remove dangerous potential from the meter movement. Note that the negative lead of the power supply is not grounded, since ground return is through the meters. Meters and Zener diode are bypassed with safety resistors to maintain continuity of circuit in case of component failure. If no safety resistors were used, and the grid meter opened up, for example, the cathode circuit voltage would soar to nearly the plate circuit potential!

1980
1980
CALLBOOKS
See page 34 for super value
on 1980 Callbooks.
1980

potential. Occasionally 4-400A or 4PR400A tetrodes can be found, and these will run 1 kW PEP or CW per tube. Likewise, the 4-1000A or 4PR1000A is suitable for grounded-grid service at 2 kW PEP or continuous duty power level.

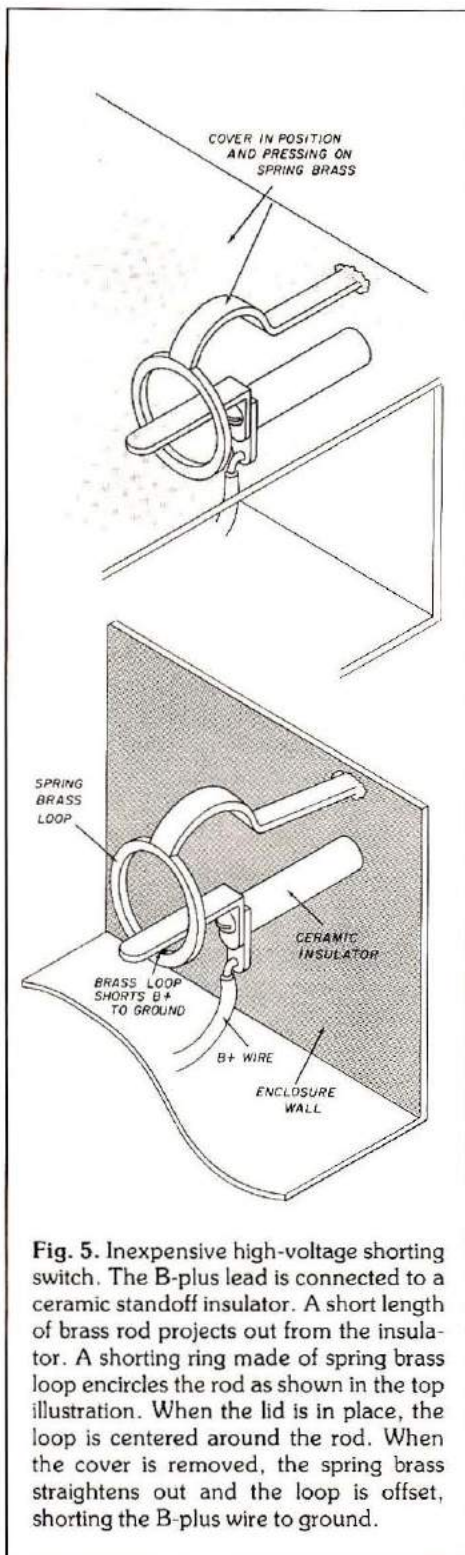

Fig. 5. Inexpensive high-voltage shorting switch. The B-plus lead is connected to a ceramic standoff insulator. A short length of brass rod projects out from the insulator. A shorting ring made of spring brass loop encircles the rod as shown in the top illustration. When the lid is in place, the loop is centered around the rod. When the cover is removed, the spring brass straightens out and the loop is offset, shorting the B-plus wire to ground.

Table 1. 813 tube in rf linear amplifier service for SSB and CW, cathode driven, grounded-grid service.

General Characteristics

Filament voltage	10.0 volts
Filament current	5.0 amperes
Output capacitance	14 pF

Typical Operation (one tube)

DC Plate voltage	2500 volts
Approx. zero signal plate current	30 mA
Max. signal plate current	225 mA
Max. signal total grid current	50 mA
Plate load impedance	6000 ohms
Driving impedance	270 ohms
PEP Plate input power	560 watts
Useful output power	340 watts
Max. signal driving power	14 watts

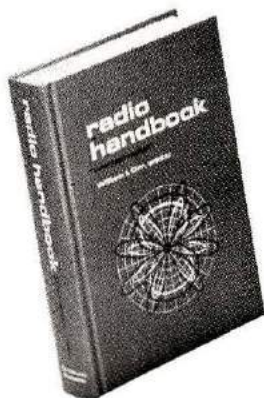

Useful Information You Should Have

An aid in obtaining inductors for this amplifier, and useful for future products, is the General Catalog of the J.W. Miller Division, Bell Industries, 19070 Reyes Ave., Box 5825, Compton, California 90224. Address your request to Mr. Bill Courtney.

References

- William I. Orr, W6SAI, *Radio Handbook*, 16th edition, section 29-8, "An 813 Grounded Grid Linear Amplifier." Editors and Engineers, Ltd. (Out of print.)
- William I. Orr, W6SAI, *Radio Handbook*, 21st edition, chapter 22. Howard W. Sams Co., 4300 West 62nd St., Indianapolis, Indiana 46206. (\$21.50 from Ham Radio's Bookstore, Greenville, New Hampshire 03048).

HRH

MAGAZINE SAMPLES

For a free list of over 100 magazines offering a sample copy send stamped envelope to

PUBLISHERS EXCHANGE

PO Box 1368, Dept. 26A
Plainfield, NJ 07061

HI-Q BALUN

- For dipoles, yagis, inverted yees & doublets
- Replaces center insulator
- Puts power in antenna
- Broadbanded 3-40 MHz
- Small, lightweight and weatherproof
- 1:1 Impedance ratio
- For full legal power and more
- Helps eliminate TVI
- With SO 239 connector

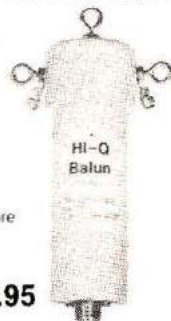

\$10.95

HI-Q ANTENNA CENTER INSULATOR



Small, rugged, lightweight, weatherproof. Replaces center insulator. Handles full legal power and more.

\$5.95 With SO 239 connector

HI-Q ANTENNA END INSULATORS



Rugged, lightweight, electrically insulating. High quality materials, with high tensile strength and excellent weatherability. End insulators are constructed in a split, unfolding fashion to permit winding of loading coils or partial windings for hand traps.

- May be used for Guy wire strain insulators
- End or center insulators for antennas

\$4.95 Construction of antenna loading coils or multiband traps

DIPOLES

MODEL	BANDS	LENGTH	PRICE WITH HI-Q BALUN	WITH HI-Q CENTER INSULATOR
Dipoles				
EI-80	80-75	1-00	\$28.95	\$32.95
EI-40	40-15	0-60	25.95	29.95
EI-20	20	0-30	24.95	29.95
D-15	15	0-20	23.95	29.95
D-10	10	0-16	22.95	28.95
Shortened dipoles				
SD-80	80-75	0-90	21.95	27.95
SD-45	45	0-45	20.95	24.95
Parallel dipoles				
PD-80/40	80-40/20-10	1-00	35.95	41.95
PD-40/20	40/20/10	0-60	32.95	39.95
PD-20/10	20/10/5	0-30	30.95	37.95
PD-10/5	10/5/2.5	0-15	29.95	36.95

Dipole shorteners - only, same as included in SD models
S-80 \$11.95
S-40 \$10.95

All antennas are designed to work with HI-Q Balun or HI-Q Antenna Center Insulator. All HI-Q antennas are ceramic insulators. 100 million antenna support tower (AT) models only. See listing for full legal power. Antennas may be used as an inverted V, and they are also covered by MARSH'S PATENTS.

Antenna accessories - quantities with antenna listed
No. of Guy Wires 40-100 ft. Guy Wire \$1.99
Ceramic Standoff Insulator \$1.99
SO 239 Connector \$1.99

Available for purchase in the USA only

Van Gorden Engineering
BOX 21203, S. EUCLID, OHIO 44121 Dealer Inquiries Invited

DX Horizons

By Bill Kennamer, K5FUV

Welcome to the world of DX, a black-magic world of many fascinations. Who is interested in DX? In some way, all of us are. The casual rag-chewer gets a thrill when a faraway station calls. Even those who operate 2-meter repeaters become excited when faraway mobiles begin calling into their system. In each of us lives the spark of the DXer, waiting to be released. Come join us, then, as we go monthly through this magic world, and learn more about the people and places that make a world wide.

Each month in this space I will present information about DX happenings, operating tips, and other news that DXers may find useful. Much of the information will concern the operators and the locale of DX operations. I'll try to let you know something about the people, so that you might meet an old friend when you work him on the band.

Kiribati

The Gilbert Islands became an independent republic on July 12, 1979. Since then, much confusion has existed as to what has happened to the country status of the Gilberts, Phoenix, and Line Islands. We will attempt here to explain the current status, and describe some of the happenings in the area within the past year.

These are the countries affected by the change: VR1, British Phoenix Islands; VR1, Gilbert and Ocean Islands; and VR3, VR7, Line Islands. Also affected is the KH1 group of Baker, Howland, and American Phoenix Islands.

T3K, Kiribati (formerly VR1, Gilberts, includes Ocean Island, now

known as Banaba, and Tarawa).

T3P, Phoenix Islands (VR1, British Phoenix, including Canton Island, and KH1, American Phoenix, also including Canton Island).

T3L, Line Islands (formerly VR3 and VR7, Line Islands). The American and British Phoenix Islands were jointly administered by the U.S. and United Kingdom. Both have agreed to give control to American Phoenix. When the U.S. signs the treaty, (soon, if not by now) American Phoenix will be removed from the countries list. However, since American Phoenix shares the list with Baker and Howland, no loss of DXCC country results. The only loss is that American Phoenix will no longer count in the KH1 group.

T3K, T3P, and T3L will still count as separate countries because of the distance criteria. Thus, there is really no loss, no gain — just confusion.

During the changover, an unusual situation was created in that one station counted for two countries. Larry Gandy, KS6DV, came over from American Samoa to Canton Island to help out with communications for the government during the changeover. While there, he was issued the call VR1PJ for the British Phoenix Islands, and operated as KS6DV/KH1 for American Phoenix. Thus by exchanging two signal reports, he could count for two countries. Larry was subsequently issued the call T3PA, and has since returned to American Samoa.

This two-country approach was also attempted by VR1BE, but was not acceptable. The reason for non-acceptance was quite simple. VR1BE was an American citizen who obtained a license for British Phoenix

but did not have an American Amateur license. He did some operation as VR1BE/KH1. However, as an American citizen, he would have needed an American license to operate for American Phoenix credit. American citizens do not qualify to operate in U.S. territory using a license issued by another country, even if a reciprocal agreement exists. Such agreements were made only for non-citizens, thus the /KH1 operation could not count.

Willy, T3KC, is another operator in Kiribati. He has recently used three calls: VR1AY, from January 1 to January 22, 1979, only; VR1PK on Canton Island; and his home call, VR1BD, on Tarawa. His new call is T3KC. He spent several months at the end of the year on Canton, originally as temporary duty, but was delayed there when the aviation fuel-supply storage tanks became contaminated and delayed all out-going flights. By the time of this writing, he was expected to have returned to Tarawa by boat.

Svalbard

Svalbard, also known as Bear Island, has been recently activated by four operators, out for a winter tour of duty. Rey, JW1SO, has been very active, including several stints on the Africaner net on 21.355 MHz. He has been worked on all bands, including 80 meters. Rags, JW7FD, also has been very active, appearing on 14.32

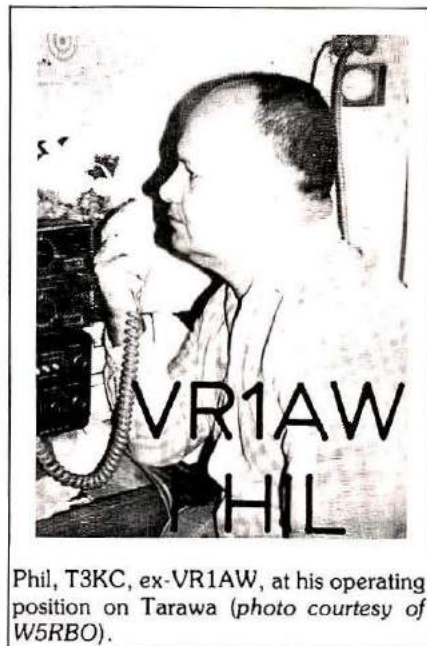

Phil, T3KC, ex-VR1AW, at his operating position on Tarawa (photo courtesy of W5RBO).

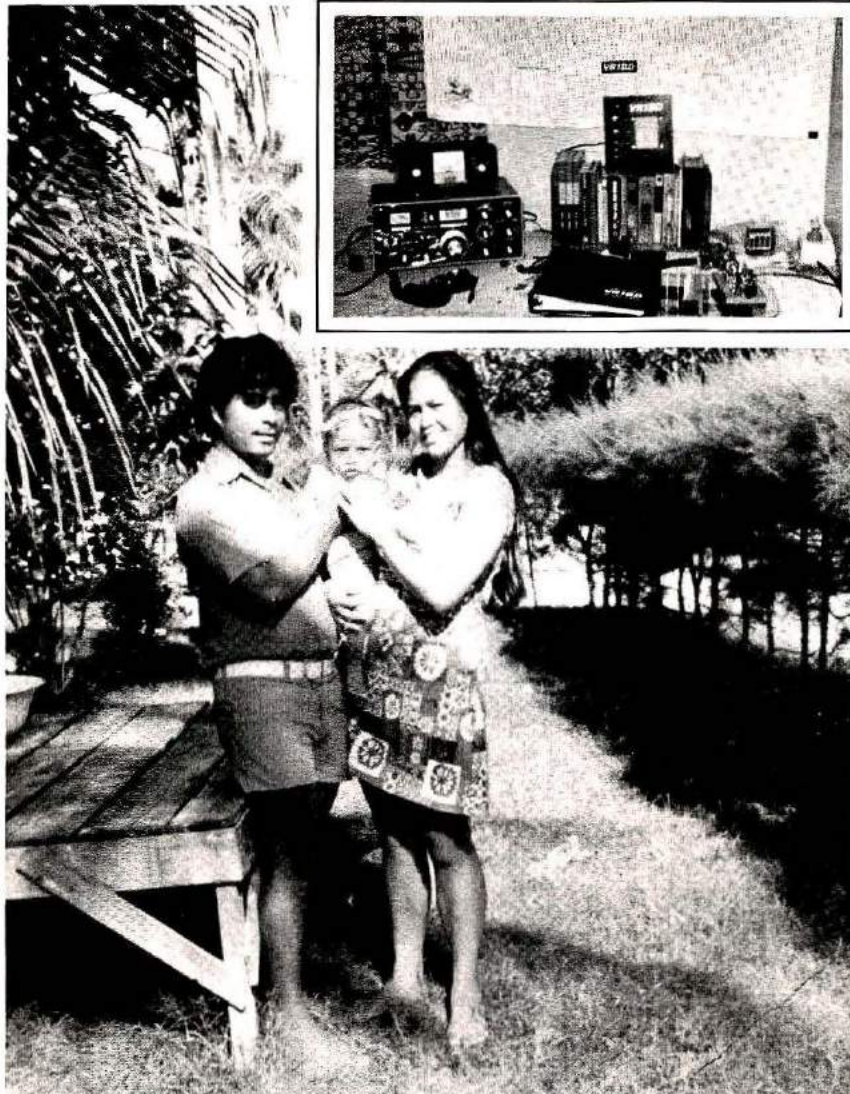

Willy, T3KC, ex-VR1BD, AY, PK, on Tarawa, is seen here with his XYL and young nephew. In the box is a photo of Willy's station. He's QRV on all bands, 160 through 10 meters (photo courtesy of W5RBO).

MHz, 0400Z, first and third Mondays. Also, he's been on 14.05 MHz, 0400Z, second and fourth Mondays. Also on the island, but not quite as active, are JW5IJ and JW8FG.

Antennas are a three-element tri-bander; a two-element, 40 meter beam; and a delta loop for 80 meters. They will be there until June, 1980, so the deserving will have their chance.

Jan Mayen

Jon Fadnes, JX9WT, is one of the operators at a commercial radio station. He will be on Jan Mayen until March, 1980, but has a three-element

beam and linear amplifier to keep him company. He has shown a preference on this and other trips for operation on or around 14.22 MHz, SSB. Also, he has been appearing with Stieg, LA7JO, at 2300Z at 3.795 MHz each Saturday, going to 7.085 MHz split at 2330Z. If you missed him this season, don't despair, he will most likely be back there in mid-November.

United Arab Emirates

Ed Perkins, W5TKZ, is now operating /A6 from the Presidential Palace in Abu Dhabi. He is operating at this time under unusual circumstances.

About a year ago, all A6 licenses were cancelled and equipment was confiscated, resulting in complete termination of Amateur activity in the United Arab Emirates. Since that time, Ed is the only operator to have been on from there. He is operating with verbal permission of the President, using the President's own global communications system, including a kW transmitter and log periodic antennas. He cannot operate while the President's plane is away, but can be heard regularly otherwise.

In order to operate, he must be under some restraints. He is limited to 14.240 to 14.270 MHz, phone only, between 0400-0600Z. Also, note this: all communications with this station are monitored. He must have someone in attendance at all times. The communications minister is keeping an eye on this operation, as he is now reviewing actual licensing, including reciprocal licensing, for some action in the immediate future. So remember, as you work or call this station, your actions in a pileup or QSO could affect future licensing in this rare country. If you want A6 back on the air on a permanent basis, be nice!

Mali

How would you like to go to a very rare African country with your first-ever high-frequency license? That's exactly the position that Jan, TZ4AQS, found himself in recently. Mali has been extremely rare over the last several years, but recently restrictions eased somewhat, and Jan, who had only vhf privileges at home in the Netherlands, was able to obtain a license to operate.

Jan is from a part of the Netherlands where they speak the language of Northern Belgium. Thus, when he was heard checking into the Dutch net on 14.104 MHz, ON5NT and ON6BC were able to meet him and schedule operations up in the American phone band. The ON operators were able to provide tutelage, and brought Jan up to 15 meters for some list type operations. As he began to gain experience and enthusiasm, he began to operate by himself, both split and transceive. He will continue to change frequency without announcing it, however, if a pile-up becomes unruly.

Horizons



Larry Gandy, KS6DV, at the operating position of VR1PJ/KS6DV/KH1. During this operation, Larry was in the unusual position of being able to count for two countries at the same time (photo courtesy of KS6DV).

QSL Information

Station	QSL Via
A22DR	Anush, Box 269, Garborone, Botswana
CO2JA	Box 2004, Havana, Cuba
D68AP	WB2OHD
FB8ZO	F6EYB
FP8AX	VE3AX
HH2A	AJ9D
HS1ABD	K3EST
KX6PP	WD4NVH
K9EF/8R1	K1RH
OD5BC	Box 1746, Beirut
OD5JU	9G1JU
PY0ZAE	W1DA
SV1DC/5	Box 161, Athens
TF3YH	WA8AEE
TF0TJ	Tom Jenkins, Box 22, G14 FPO New York 09571
TR8DCD	Dennis, Box 836, Libreville, Gabon
VQ9PC	K9KLR
VQ9TC	W3HNC
VU2RX	W2LOG
WA7JRL/SU	W8LZV
WB5LBJ/DU6	W7HPI
W6BD/CE1	W6STQ
ZD7HH	W4FRU
ZF1MA	VE3GCO
ZF2CV	N5JC
ZF2DD	KA5Q
5N4ROF	W4FRU
5U7BE	DF3NZ
5Z4YV	JA2AJA
6W8DY	VE4SK
6W8EN	Box 2985, Dakar, Senegal
7P8BJ	Box 39, Maseru, Republic of Lesotho
7P8BQ	K9KXA
9G1DY	Norman, Box 2949, Accra, Ghana
9Q5GB	W7KTI

At present, Jan's signal is not particularly strong, as he is using low power and a long-wire antenna. He is returning to Europe for a short time, and plans a stronger signal on return. He is working on a construction project, and will return to Mali for a two-year stay.

DX Club News

Officers for the Southeastern DX Club for 1980 are as follows: Dwight Dover, KA4C, President; Dave Johnson, WA4SSU, Vice President; Allen Bond, WB4GNT, Treasurer; Wayne Mueller, W4LVM, Activities Chairman; Bill Dunbar, WA4VDE, Secretary.

Virginia Century Club officers for 1980: President, Glen Bashford, K4TIA; Vice President, Charlie Keil, AA4CK; Secretary/Treasurer, Jim Bishop, WA4MAV.

Southern New England DX Association's 1980 officers are as follows: President, Bill Poellnitz, K1MM; Vice President/Secretary, Jim Dionne, K1MEM; Treasurer, Peter George, WA1HXH; Activities Manager, Jeff Bouvier, K1TU.

Until next month

We will return in this space next month to bring more news about DX and DX-related activities. Your news is important to us, so if you have any information and photos you would like to share, please let us know. You can send it to DX Editor, c/o *Ham Radio Horizons*, Greenville, New Hampshire 03048.

Thanks to all of you who supplied information to *QRZ DX*, a weekly newsletter from which much of the information was drawn.

Last minute news

Gun, YN1Z, H7Z, (ex YN1CW) advises that he was active from Managua through the end of June, 1979. All outstanding QSLs will be answered by K4CLA, 562 Oak Drive, Lexington, South Carolina 29072.

NN3SI frequency schedule

Special-Event Station NN3SI, operating from the Nation of Nation's exhibition of the Smithsonian Institution, will adhere to the following schedule in the 75, 40, 20, 15, and

10 meter bands, consistent with band conditions and available clear channels close to the desired frequency points:

General Monitoring (Monday-Friday):

1300-1345 UTC — 7090 kHz

1700-1800 UTC — 7265 kHz

General Monitoring (Sunday):

1800-2130 UTC —

28.1-28.2 MHz

or — 21.1-21.2 MHz

Daily Scheduled Operation:

Monday:

1900-2000 UTC — 28.640 MHz

2030-2130 UTC — 14.220 MHz

Tuesday:

1900-2000 UTC — 28.640 MHz

Wednesday:

1900-2000 UTC — 28.640 MHz

Thursday:

1500-1700 UTC —

28.030-28.040 MHz

1800-1900 UTC —

21.030-21.040 MHz

1900-2100 UTC —

14.030-14.040 MHz

Friday:

1900-1945 UTC —

21.255-21.265 MHz

2015-2100 UTC —

21.155-21.165 MHz

2130-2200 UTC — 3925 kHz

Saturday:

1900-2000 UTC — 14.300 MHz

Sunday:

1500-1700 UTC — 7125 kHz

1900-2000 UTC — 28.640 MHz

The station has a dual console and, during peak activity, will also operate other frequencies in the high frequency spectrum and 2-meter fm. Special-mode operation, including RTTY and SSTV, will be announced in a subsequent bulletin.

NN3SI is operated in conjunction with the Smithsonian Amateur Radio Club and the Independent Volunteer Placement Service of the Smithsonian Associates. Management is by the staff of the Division of Electricity and Modern Physics. QSL address: NN3SI — Smithsonian Institution, Washington, D.C. 20560. **HRH**

Our smart machine reads sloppy copy.

New! Includes 24-hour UTC clock, 110 and 300 baud ASCII, & tuning eye!



Kantronics

Field Day[®]

\$449.95

If someone tells you they offer the same features we do, check them out with the list below. Kantronics offers the finest in state-of-the-art technology through over 35 dealerships in the United States, Canada and West Germany.

- Morse copying ability
- 3 to 80 WPM Morse range
- Computer programs for improving sloppy Morse
- Radioteletype copying ability - 60, 67, 75 and 100 WPM Baudot
- ASCII radioteletype ability - 110 and 300 WPM baud
- Copies any shift of RTTY
- 24-hour UTC clock available in any mode
- Entire unit contained in one package
- Automatic code-speed tracking
- Full 10-character, large-size display
- Displays code speed
- Tuning eye for faster tuning
- Full year limited warranty
- Internal speaker
- Requires no TV set for use
- Advanced demodulator circuits
- Internal 200 Hz bandwidth filter
- All letters, numbers and punctuation plus 8 special Morse characters and 5 special RTTY characters
- 15-day trial period.

Send for our free brochure that explains the Field Day system of Morse and RTTY decoding. Or you can order from one of our dealers or our factory today. Our number is below, give us a call.

Special SWL model - \$464.95

Free

Code Reading Made Simple

Okay, tell me more.

Name
Address
City

State
Zip

Kantronics
1202 E. 23rd Street (913) 842-7745
Lawrence, Kansas 66044

FCC Answers Some Questions

BY GORDON WEST, WB6NOA

All of us have had to answer questions set forth by the FCC at one time or another in our quest for an Amateur Radio ticket, but now it is time to turn the tables. In a search for the person largely responsible for the new exam questions, and the syllabus which they have just compiled to tell you what subjects you should study, I found Jay Jackson, of the FCC's Amateur Radio Rules Division. Jay deftly fielded my questions, and was willing to talk quite frankly about the new exams and the possibility of a new type of code examination.

Q. When will the new 1980 syllabi be available at Field Offices for Amateur Radio operators to review in preparing for their exams?

A. "We had originally intended for our new syllabi to be available in February of this year. Unfortunately, due to printing problems, it was delayed by about 60 days."

Q. Does this mean that the new exams will be delayed?

A. "Yes. We want to be sure that people have a chance to review the new syllabi prior to taking the new Amateur exams."

Q. When do you think the new exams will go into effect?

A. "We were trying for March, but it could be in April or at the latest, the first of May. We will issue a news release indicating the exact date when the new exams will be put into use."

Q. Have the exams already been sent out to your Field Offices?

A. "Yes, by registered mail. All 30 Field Examination Offices have been sent the exams in quantity, and we're now waiting for registered mail confirmations that they have arrived."

Q. Will the new exams be added to the older exams, or will the new exams completely replace older exams?

A. "Absolutely so!"

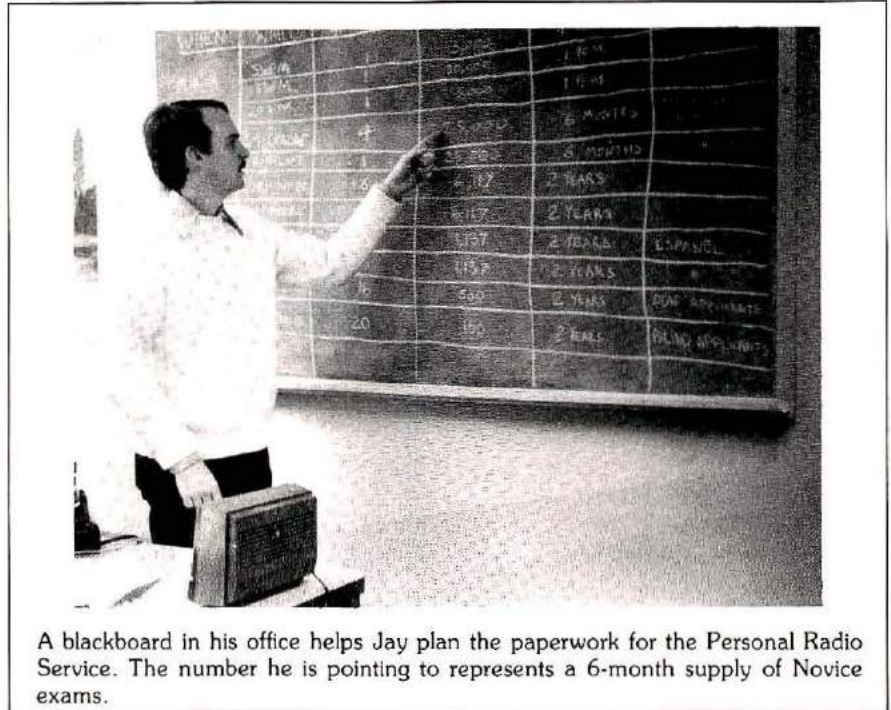

A blackboard in his office helps Jay plan the paperwork for the Personal Radio Service. The number he is pointing to represents a 6-month supply of Novice exams.

Q. Absolutely so, what?

A. "They will absolutely replace all of the older exams. The older exams will be destroyed and only the new exams given."

Q. Is there just one version of the new exam for each element?

A. "I am sure that people are aware that we have more than one version at every level. While they are the same questions, they have different permutations — so you really don't know which grading mask will be used. That way we can keep people from just coming in and remembering a b a b c d e."

Q. Are these the exact same questions in each of the versions, or are they slightly different?

A. "We have a question set for each level. Each question set contains more questions than an examination for that level does. These questions are derived directly from our January 1980 syllabi. That's why it's important

to get a copy of the syllabi before taking any of our new exams."

Q. Hows many versions will there be for each element?

A. "That's not information that I can give out. There are more than one . . . there are more than two . . ."

Changes in the questions

Q. Many hams feel that the present tests have more than one correct answer. They also feel that some of the questions have been made tricky to throw you off of the right answer. Are these new questions simply a reworking of the older questions?

A. "The old question sets are kind of a legacy — they've been handed down and used over and over. We have made some changes in these questions, and, we have drafted some new ones also."

Q. What will the new questions be like?

A. "There will be only four possible

choices. Only one will be correct. We call the incorrect answers 'distractors.' I have also made a personal effort to purge those questions which use any sort of logical operation such as 'none of the above,' or 'all of the below.' That stuff is all gone. I've tried to make sure that the questions, as well as the answers, are as clear as possible. No tricks. Furthermore, every correct answer is verified by a reference, and the incorrect answers are completely incorrect."

Q. Is this a departure from what you have seen in the past with questions and answers?

A. "Yes, in the past, we have had questions that call upon the examinee to rank the answers — in other words, to determine which of the ones below are best, but several of them are right. Now this doesn't mean that we're not going to include in the new exams questions that begin, 'Which one of the following best describes . . .'"

Q. But wrong answers will be completely wrong?

A. "Yes, the distractors will be completely wrong. I think that the complaints that we've had about questions being tricky will be reduced. That's my hope!"

Q. Can we then assume that you are pretty much responsible entirely for the amateur radio testing program?

A. "Let's say 70 percent, Gordon. About 40 people have assisted me with the new syllabi. We received a tremendous response from Amateur operators wishing to help us develop the new syllabi."

Q. So it sounds like you are responsible for the creation of the new tests, but had some outside advice.

A. "That's correct — from other Amateurs, professional educators, consulting engineers; and I studied . . . I read several books about the principles of good test-item construction. As an electronics engineer, as well as a radio Amateur, I feel that the exams will be accepted by the Amateur Radio community."

Q. What are the new questions like — will there still be the same emphasis on technical as well as operation of Amateur Radio equipment like the old questions?

A. "When you review the Study

Guide, you will see there are changes. Our responsibility at the Commission is to try to prevent interference and to ensure that each radio service gets good quality communications without interference. Along these lines, the Communications Act requires us to issue operator licenses only to people who are qualified, considering what they are allowed to do. In Amateur Radio, hams are allowed to do lots of things with radio — so we test the operator. We want to make sure that the operator can reasonably be expected to operate a transmitter without causing interference."

Q. What about the Novice level?

A. "You'll find it's very basic. We don't even cover Ohm's Law in the Novice test anymore. It's just 'What do you need to know to operate a Novice station without getting into trouble.'"

Q. What about the test for technician and General Class, Element 3?

A. "You'll see that the emphasis in Element 3 is on operating — what you need to know to be a good radio operator. We don't really get too deep into electronics with our Element 3 questions. Generals have access to things like DXing, contests, and enjoyable operating type things. This is why our emphasis is on operating topics."

Q. What about the Advanced test?

A. "With an Advanced operator, we are making a statement that this person has shown himself to be distinguished in Amateur Radio. On the Advanced level, you're going to run into some of the technical questions that were formerly on the General exam. In other words, you'll have to be able, for the Advanced test, to figure resonance, circuit Q, and things like that."

Q. And what about the Extra Class exam?

A. "The Amateur Extra Class exam does have some topics that, if you know them, you can really say you're at the top of the Amateur Radio technical pyramid! We don't expect that everybody out there will get to the Amateur Extra level. If everyone could pass the test, it really wouldn't have that much meaning. The past tests for Extra covered some pretty esoteric levels of electrical knowledge — such as why would you use a lighthouse tube, or, how is propagation at 10 GHz. Although this may be nice to know, and I'm sure that there are a few people who know these facts, it's not really what you would call mainstream Amateur Radio. The new Extra Class test relates to Amateur Radio technology as it is today."

Q. Just a couple of last questions,

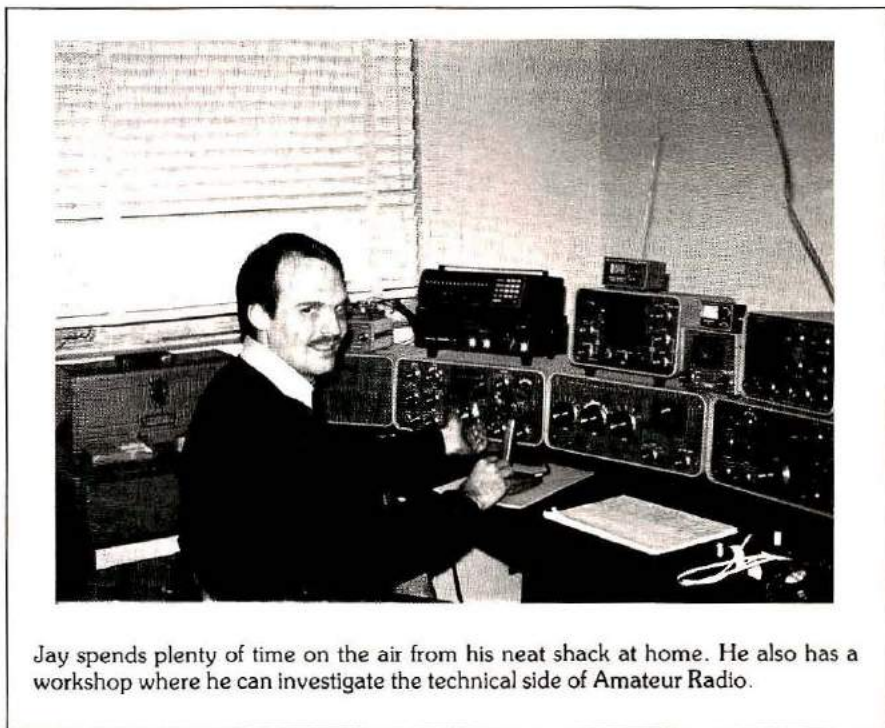

Jay spends plenty of time on the air from his neat shack at home. He also has a workshop where he can investigate the technical side of Amateur Radio.

Operate Legally Without An FCC License in the 160-190 kHz Band



LOW & MEDIUM FREQUENCY RADIO SCRAPBOOK (3rd Edition)

by Ken Cornell, W2IMB

Here's your chance to get on the air and have some legal license-free excitement in the 160-190 kHz range. Explore the enticing world of the low frequencies and uncover some new fun! Complete details on assembling homebrew to work these frequencies plus full info on FCC rules and regulations. A book you just can't afford to miss. 110 pages. ©1977.

HR-LF

Softbound \$6.95



ADDENDUM '77/'78 for the Low & Medium Frequency Radio Scrapbook

by Ken Cornell, W2IMB

Even more goodies from the 160-190 kHz region. Addendum '77/'78 is designed to complement *The Low & Medium Frequency Radio Scrapbook*. The technical data is excellent and will provide you "low-fers" even more information, applications, and techniques for these enticing frequencies. Latest revised FCC rules governing the non-licensed communication bands. 68 pages. ©1977.

HR-LFA

Softbound \$3.95

Be a LOWFER

Join the fun and get on
160-190 kHz

Send your order today or call

TOLL FREE
1 (800) 258-5353

Clip & Mail Today!

HR-LF

\$6.95

HR-LFA

\$3.95

Plus shipping

\$1.00

Total enclosed _____

Charge

MC

VISA

Expiration _____

Card Number _____

Name _____

Address _____

City _____

State _____

Zip _____

Ham Radio's Bookstore
GREENVILLE, NEW HAMPSHIRE 03048

Jay, and one is, what about the code test. A lot of hams still feel that missing a single letter can cause them to miss a question where answers are only a letter or two apart.

A. "It is true that on current telegraphy tests you still need to copy accurately most of the message sent, and some answers are similar in spelling. However, we've come a long way from the earlier telegraphy tests where you had to copy one minute letter-perfect. Those tests were actually a concentration type of test, rather than a content type of test that we now have. I think that the concentration type of test was finally let go because, among other things, it really didn't reflect the ability you need in telegraphy for Amateur Radio today."

Q. Isn't today's test for code almost like the other "concentration" type of test?

Will the exam for code be changed in the near future?

A. "In some ways, yes. But today, we're using QSO type messages just like one might expect to copy on the Amateur Radio bands. It's much easier now because the examinee will probably know what is going to be coming."

Q. But what about the answers on the code test being all so very close in spelling?

A. "If they were radically different, it would be easy to just copy a few letters, and make an educated guess as to what the answer is."

Q. Will the exam for code be changed in the near future?

A. "Yes. Our Field Bureau has uncovered quite a bit of reliable evidence that our CW tests have become compromised."

Q. So you're going to change your code test format?

A. "We have devised another type of

telegraphy test. We are going to try out this new test for code in the near future to see whether or not it's feasible to administer."

Q. Feasible?

A. "From our standpoint, feasible means that it doesn't take a lot of our time to score or to grade it. Our Field Bureau is pressed for resources that they need for other services. Multiple choice tests are easy to score — but also easy to compromise, too."

Q. Will this new type of code test be harder or easier to pass?

A. "If you can copy code at the prescribed speed, you will pass either the present test, or the new one. However, if given a choice, I suspect most people would prefer a multiple choice type of question because they always have a chance of getting the right answer by guessing."

Q. So who are going to be the guinea pigs on this new type of exam?

A. "When we initially try out this new type of code test, we'll allow anyone who fails it to take the multiple choice one; they'll have two chances to pass. Later, if it's feasible, we'll switch over exclusively to the new type test."

Q. Will this new code test still be like a regular Amateur QSO, or might it be code groups?

A. "It will still be like regular Amateur QSOs."

Q. In structuring new tests for the Amateur Radio Service, I'm sure you must have ideas as to where we are, and where we are going with our service.

A. "I feel that there are three types of hams who make up the Amateur Radio Service — they're either operators exclusively, experimenters exclusively, or a combination of both. I personally prefer to do a lot of building, and some operating. There's room in the service for all three categories. All of these categories make a contribution to the Amateur Radio Service."

My thanks go to Jay Jackson of the FCC's Private Radio Bureau, Rules Division. Jay is active on the air when he's not building equipment, call signs AF40 and KSW1512. It sounds like we have a lot to look forward to in improved, "humanized" FCC Amateur Radio exams. **HRH**

1 GHz For Only \$139.95

8 Digits • 1 PPM TCXO • Factory Wired 500 MHz or 1 GHz

\$139⁹⁵
5510 WIRED
50 Hz to 1 GHz

\$109⁹⁵
5500 WIRED
50 Hz to 512 MHz

• 1 Hz Resolution to 50 MHz.

- 1 Meg Ohm, 50 Ohm, BNC Inputs
- 15 MV Sensitivity at 250 MHz Typ.



With the introduction of the 5510 DSI has filled a long standing void in the frequency counter market place. You now have the choice of selecting a 512 MHz model 5500 for \$110 or for only \$30.00 more you can buy an 8 digit 1 GHz counter model 5510. With this 1 GHz capability, the new world of 960 MHz is immediately available to you. Both the 5500 and 5510 are available with a rechargeable battery pack which includes the AC adapter and battery charger for one low price. Whether you select the 5500 or the 5510, you will receive the best price to quality features ratio in the industry. No wonder DSI has become one of the world's largest manufacturers of freq. counters

1.2 GHz Only \$199⁹⁵

5612 KIT

512 MHz Only \$169⁹⁵

5600 KIT

10 MHz Proportional Oven

- .2 PPM 10° to 40° C Time Base
- .1 Hz Resolution to 50 MHz.
- External 10 MHz Inputs outputs.
- 9 Bright .5 inch LED Readouts.
- 100% Factory Tested
- Kits 95% Factory Assembled.
- 50 Ohm, 1 Meg, BNC Inputs
- 10 MV Sensitivity at 250 MHz Typ.



Whether you select a 5600, 5612 Kit with 95% of the assembly completed by DSI or select a factory wired and calibrated frequency counter, you can count on DSI to solve all those difficult bench or field problems from measuring audio signals to checking a 960 MHz mobil radio (model 5612), servicing a VTR, trouble shooting a PLL signal in a TV or FM radio, etc. The 5600 or 5612 has the sensitivity and accuracy to meet any FCC landmobile, broadcast, RF, or telecommunications requirements. DSI offers a 10 HR rechargeable battery pack (BA56) option, and an audio multiplier (AM56) which will allow you to resolve a 1/1000 Hz signal in only ten seconds or 1/100 Hz signal in one second. DSI 5600 series offers just the right instrument for all your communication RF, TV servicing and industrial testing needs.

FOR INFORMATION — DEALER LOCATION — ORDERS — OEM
CALL 800-854-2049 CALIFORNIA RESIDENTS CALL 800-542-6253

Model	Price	Frequency Range Typ	Accuracy Over Temperature	Sensitivity Typ			Number of Readouts	Power Requirements	Size H x W x D
				@ 100Hz-25MHz	@ 50-250MHz	@ 50-950MHz			
5600A-Kit	\$199.95	50Hz-350MHz	Proportional Oven 2 PPM 10° - 40°C	10-25mv	10-15mv	15-50mv	9	*115 VAC or 8.2-14.5 VDC	3 1/4" x 9 1/2" x 9"
5600A-Wired	\$199.95			10-25mv	10-15mv	15-50mv			
5612Kit	\$199.95	50Hz-1.2 GHz	Proportional Oven 2 PPM 10° - 40°C	10-25mv	10-15mv	15-50mv	9	*115 VAC or 8.2-14.5 VDC	3 1/4" x 9 1/2" x 9"
5612 Wired	\$239.95			10-25mv	10-15mv	15-50mv			
5500 Wired	\$109.95	50Hz-512MHz	TCXO 1 PPM 17° - 40°C	10-25mv	15-25mv	25-75mv	8	115 VAC or 8.2-14.5 VDC or NICAD PAK	1 1/2" x 5" x 5 1/2"
5510 Wired	\$139.95	50Hz-1GHz		10-25mv	15-25mv	25-75mv			

Factory wired units carry 1 year limited warranty kits carry a 90 day limited warranty.
Prices and/or specifications subject to change without notice or obligation.

*With AC-9 Adapter

Prices effective
March 1, 1980

- 5510 Wired 139.95
- 5500 Wired 109.95
- 5510/BAC Wired 164.95
- 5500/BAC Wired 134.95
- T600 BNC ANT (all models) 7.95
- AC-9 AC Adapter(all models) 7.95
- LC 5000 169.95

INTERNAL BAT. ONLY AC-9 NOT REQUIRED

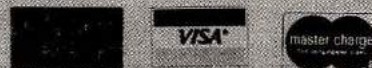

DSI INSTRUMENTS, INC.
9550 Chesapeake Drive
San Diego, California 92123
(714) 565-8402

TERMS: MC — VISA — AE — CHECK — M.O. — GOD
in U.S. Funds. Please add 10% to a maximum of \$10.00
for shipping, handling and insurance. Orders outside
of USA & Canada, please add \$20.00 additional to
cover air shipment. California residents add 6% Sales Tax

- 5612 Kit 199.95
- 5612 Wired 239.95
- 5600A Kit 169.95
- 5600A Wired 199.95
- BA56 Rechargeable
- 10 Hr. Bat. Pack 29.95
- AM-56 Audio Multiplier
- .001 Hz Resolution 34.95

Questions & Answers

Questions and Answers

Entries for this column must be by letter or post card, only. No telephone requests will be accepted. All entries will be acknowledged when received and those judged to be most informative to the most Amateurs will be answered in this column. No questions will be answered by return mail. Questions must relate to Amateur Radio.

Readers are invited to send a card naming the question they feel is most useful in each issue. Each month's winner will receive a prize, and there will be a prize for the most popular question of the year. In case of two or more questions on the same subject, the one arriving here the earliest will be used.

Dudgeon in the dungeon

When an emissary from our office dropped by the oracle's cave to pick up this month's responses to the latest batch of cards and letters, things seemed eerily quiet and dark. He was just about to leave empty-handed when a slight rustling from within caused him to take a second look. Treading cautiously through the broken quill pens, overturned ink bottles, and half-eaten bologna sandwiches, he found the grand vizier curled up in a deep corner, muttering to himself.

It took the aroma of a cup of herb tea and a promise of a mess of fiddlehead greens in the spring to coax oracle out of the dim recesses into the light reflected into his dungeon from a nearby ski slope. In trying to ascertain what was the matter, our messenger

triggered a response that caused the bard's flowing, off-white beard to gyrate wildly, and his hair stood on end, fairly crackling with electric reaction.

Through all the tirade, our man at the front finally pieced together what was the matter. It seems a lot of the questions did not pertain to Amateur Radio! Tsk, and for shame!

You see, our answer man is really sold on Amateur Radio, and violently resents any intrusion of the non-ham world into his chosen hobby (some day, perhaps we'll get into his good graces enough that he'll let us see his

Do not depend upon your ac wiring ground for rf ground

rig). So, we've vowed to protect him from such intrusions in the future by being more careful about the mail he gets.

Tiptoeing softly away from the scratching of a freshly sharpened quill pen, our messenger picked up a few of the crumpled, stomped-on letters from the floor to see what was so objectionable. Scanners, unidentified signals in the commercial radio spectrum, CB sets, color monitors for computer graphics — our recluse is right, these are not Amateur Radio.

Anyway, here are the answers to

the chosen questions for this month. While you are reading them, we'll be out looking for those fiddleheads we promised to deliver. (What are fiddleheads? Look it up in your Funk and Wagnalls).

Grounds

Some people say a transmitter should be grounded to avoid electrical shock, yet, if a ground cable is over one-quarter wavelength long on the band you are using, there is danger of rf burns. What is a ham to do if a ground is not readily available? — James Alderman, WD5GXY.

First, let's be clear about the type of grounds required. To avoid electrical shock, you need a good ground from the equipment back to the *power line ground* or common. This means using the "third wire" in all modern house wiring. If you don't have three-prong receptacles for ac outlets in your shack, put 'em in (or have it done by an electrician). There is no harm in tying an earth ground (pipe or rod driven into the earth outside the shack, or a *metal* water-supply system) to the equipment as well. This will help protect against lightning, static buildup from wind, etc.

Now, the rf ground is a different animal. *Do not* depend upon your ac wiring ground for rf ground — the rf may have to go through the whole house (or apartment complex) looking for true ground, causing trouble as it goes. A good, *metal* plumbing system may do for the lower bands (160, 80, or 40 meters), but be sure it remains metal all the way to the pipe from the water mains (more and more plastic is being used today, which is an open circuit in any ground line).

A good pipe or rod, however, driven in the ground 3 to 6 feet and tied to your rig with a heavy braid or wire, will make a good ground for rf. Its effectiveness can be improved by adding more rods nearby and tying them together with braid, or by running a "mini-radial" system out across the lawn or under the flower bed. You can use aluminum "ground wire" sold at TV stores for these radial wires.

What if the ground point is a quarter-wavelength away from your rig?

Easy — just make the wire a half-wave long. Remember, the impedance at one end of a half-wave conductor is repeated at the other end, so if one end is at ground potential, the other will be too. You're more than a half-wave away from ground? Okay, make it multiples of a half-wave. Use as heavy a wire as you can — old RG-8, RG-11, or other coaxial cable, that is too far gone to be good cable for antenna work will serve very well. Don't coil or loop any excess cable; that will make it an rf choke. Just support it out of the way in as near a direct line as possible between your rig and ground.

Learning

I am gathering information on becoming a ham, and have come across a number of advertisements on learning code and theory. They all sound like they are good, but I just don't know which is best. Can you help me? — E. L. Sanderfur.

They are all good, but you have to find the one that tells the story in a manner that fits you. They all cover the same basic material — theory, rules, procedures, learning code, etc., but, since they are written by different people who have different styles of writing, some will make sense to you while others might be just words on a page. Pick the one that sounds like the best deal for your money, and give it a shot. If you don't seem to be making any progress, pick up another book that covers the same license class, and find the same subject in it. Sometimes just comparing the way the two books tell it will make a lasting impression. In one unusual case, a ham told us he had been through no less than five different brands of code-practice cassettes before things started to click. However, most people can pick up the code from just one or two.

In the meantime, we're sending you Ham Radio's "I want to become a ham" package and a copy of our latest Bookstore catalog, filled with aids for the newcomer.

Current flow

In transistor schematics, why is the current flow opposite from the direc-

tion of the arrow? — C. Bourgeois, Jr., N5ADK.

Ah, Ahem! It's the other way around — current flow is in the direction of the arrow; *electron* flow is opposite. Next, you're going to say, "Okay, then, why is electron flow opposite?" Well, the popular fall guy for this significant error is Benjamin Franklin and, since he's not here to defend himself, why not. The story has it that he knew electrons were flowing, but didn't have the instruments or theory to prove which direction. Therefore, he picked an answer with a 50/50 chance of being right. He wasn't.

Incidentally, a way of remembering which transistor is which goes like this: the collector supply voltage identifies the *middle* letter of the type — Positive collector = **NPN**; Negative collector = **PNP**. As to which way the arrow should point, **NPN = Not**

**Positive collector =
NPN; Negative
collector = PNP**

Pointing iN; PNP = Pointing iN Positively.

Recommended reading

Doug DeMaw, W1FB, and Jay Rusgrove, W1VD, *Solid State Basics*, ARRL, Newington, Connecticut, 1978. \$5 plus \$1 shipping and handling from Ham Radio's Bookstore, Greenville, New Hampshire 03048; order AR-BA.

Ground loops

What are "ground loops," when do they become bothersome, and how are they identified and eliminated? — Gary E. Blanken, WB3DAW.

A ground loop occurs when two circuits share a considerable path through a wire, chassis, or an earth (ground) return. They can appear in almost any electrical circuit, from

power wiring to telephone lines to radio and hi-fi equipment.

An early example and problem which was common (before improved circuits eliminated it) was when electric lines were single wires, using the earth as the return from the customer's house to the generating station. Telephone lines did the same, and, since both circuits shared the same conductor — the earth — the result was hum induced in the telephones.

Engineers today are more aware of the problems of circuit sharing, and can design equipment so that ground loops rarely happen. Amateurs, on the other hand, usually have to learn the hard way, unless they carefully follow a proven design. This can result in part of an rf circuit, for example, sharing the same path across the chassis with an audio (microphone) circuit causing rf feedback and audio howl. It can happen when a high-powered rf stage shares a few inches of chassis or wire with a low-powered, but high-gain, circuit. This results in rf oscillations that cannot be cured. Another example, that might be the cause of some annoying hum on signals, is seen where an ac path (part of a power supply circuit) is shared by an oscillator circuit or an audio circuit.

To eliminate ground loops, make sure that all circuits have their own complete path from the source of the energy, through the device (tube, semiconductor, transformer, etc.) and back to the source. The old-timer's cure for ground-loops in audio and low-frequency rf circuits was to use a single point (tie lug) on the chassis as a common return for everything associated with one stage, and use a separate one as the return for the next stage, and so on.

In rf stages, make sure that the connections for the output of an amplifier use the shortest possible route for both the center conductor and the outer shell back to the amplifier, and that this path does not cross or share a path that goes to the input of that amplifier. The higher you go in frequency, the less "distance" is required to form a ground loop — an inch or two of "shared" circuit can cause big trouble at 2 meters. **HRH**

JUST GETTING STARTED?

do it right with

MADISON ELECTRONICS AND KENWOOD

The folks at Madison Electronics have long been happy to serve the newest members of the amateur community, and are proud to present these two "Getting started" packages. Pick the one that's right for you, and get started right.

STARTER PACKAGE 1



Here's your chance to start with one of the hottest new rigs around and receive a free accessory in the deal. The TS120S solid state transceiver, featuring 80-10 meters, SSB and CW with VOX and IF shift. Small enough to go mobile! Top it with a free Palomar Keyer, and you're on your way.

TS-120S	\$599.00
PALOMAR KEYER	our gift
TOTAL	\$599.00

STARTER PACKAGE 2



You simply can't buy better reliability, performance and reputation than the 520 series from Kenwood, and the TS520 SE is no exception. This is a just plain good radio at a tremendous savings, when you consider the free CW filter (YK-88) and microphone (MC-50) too.

TS 520 SE	\$629.00
MC-50 MIC	our gift
YK-88 CW FILTER	" "
TOTAL	\$629.00

MADISON

Electronics Supply, Inc.

1508 McKinney • Houston, Texas 77002 • (713) 658-0268

ANTENNA BOOKS by Bill Orr, W6SAI ALL ABOUT CUBICAL QUAD ANTENNAS

The cubical quad antenna is considered by many to be the best DX antenna because of its simple, lightweight design and high performance. In Bill Orr's latest edition of this well known book, you'll find quad designs for everything from the single element to the multi-element monster quad, plus a new, higher gain expanded quad (X-Q) design. There's a wealth of supplementary data on construction, feeding, tuning, and mounting quad antennas. It's the most comprehensive single edition on the cubical quad available. 112 pages. ©1977.

RP-CQ Softbound \$4.75

THE RADIO AMATEUR ANTENNA HANDBOOK

by William I. Orr, W6SAI and Stuart Cowan, W2LX

If you are pondering what new antennas to put up, we recommend you read this very popular book. It contains lots of well illustrated construction projects for vertical, long wire, and HF/VHF beam antennas. But, you'll also get information not usually found in antenna books. There is an honest judgment of antenna gain figures, information on the best and worst antenna locations and heights, a long look at the quad vs. the yagi antenna, information on baluns and how to use them, and some new information on the increasingly popular Sloper and Delta Loop antennas. The text is based on proven data plus practical, on-the-air experience. We don't expect you'll agree with everything Orr and Cowan have to say, but we are convinced that **The Radio Amateur Antenna Handbook** will make a valuable and often consulted addition to any Ham's library. 190 pages. ©1978.

RP-AH Softbound \$6.95

BEAM ANTENNA HANDBOOK

Here's recommended reading for anyone thinking about putting up a yagi beam this year. It answers a lot of commonly asked questions like: What is the best element spacing? Can different yagi antennas be stacked without losing performance? Do monoband beams outperform tribanders? Lots of construction projects, diagrams, and photos make reading a pleasurable and informative experience. 198 pages. ©1977.

RP-BA Softbound \$4.95

Please add \$1.00 to cover shipping and handling.

HAM RADIO'S BOOKSTORE

GREENVILLE, N. H. 03048



*Feel like you're
missing something?*

You are if you don't have a subscription to the "NEW" Ham Radio HORIZONS.

Here are some exciting features from the upcoming June issue:

- W6NIF on Trap Beam Antennas
- Ten-Tec Triton Owners' Report
- DX from K5FUV
- Ham Radio Techniques
- And much, much more!

More than ever HORIZONS is your kind of magazine, written with your interests in mind. Try a subscription today. Just use the handy bind-in card found between pages 68 and 69 or send \$12 for a year's subscription to:



Greenville, NH 03048



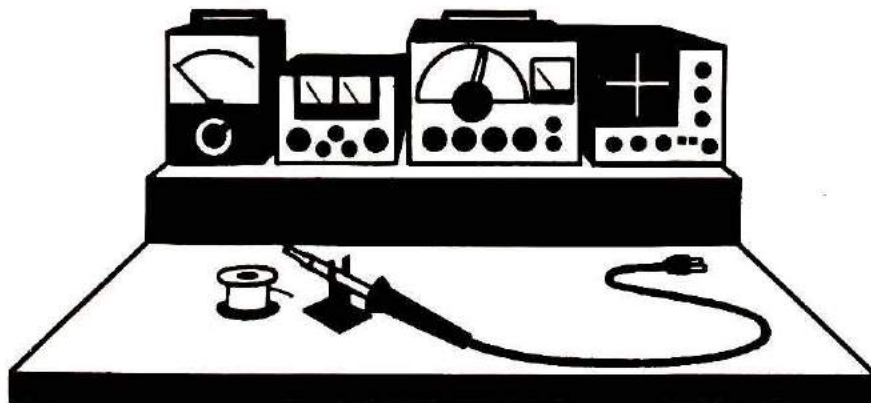

BENCHMARKS

Permanent Gin Pole

Have you ever been frustrated with the need for lowering or raising your antenna tower? My tower is free-standing, 40-feet high, with a total weight of 85 pounds; but, more than one person is required to raise or lower it. With a beam antenna attached, the weight is increased and multiplied considerably due to the law of fulcrums and levers, or something to that effect.

Being retired, I'm able to work in the yard and in the shack when my younger ham friends are of necessity involved in gainful occupations, and so I hate to ask of their spare time when they have their own projects and family activities to tend to. Recently, I found a 4 x 6 timber which looked to be a likely prospect for a gin pole that could make it possible for me to raise and lower the tower by myself.

Over the next several weeks, materials were gathered as I pictured what would be needed to make this gin pole a reality. I am not an engineer, so I gleaned ideas from antenna handbooks, tower articles, and advertisements, see Fig. 1. The steel plates used for the pulley bracket at the top of the pole were welded for me by my friend Bob, WA1VAH. The winch is a boat-trailer winch, 12:1 ratio, rated at one ton, and also has a hand brake. The greatest expense was for the cables, clamps, thimbles, and ground anchors. I just did not know where, or in what junk box, to find these. My son helped me set the pole in the ground, in line with the arc the tower would swing through as it was lowered.

The time and effort was worth it for

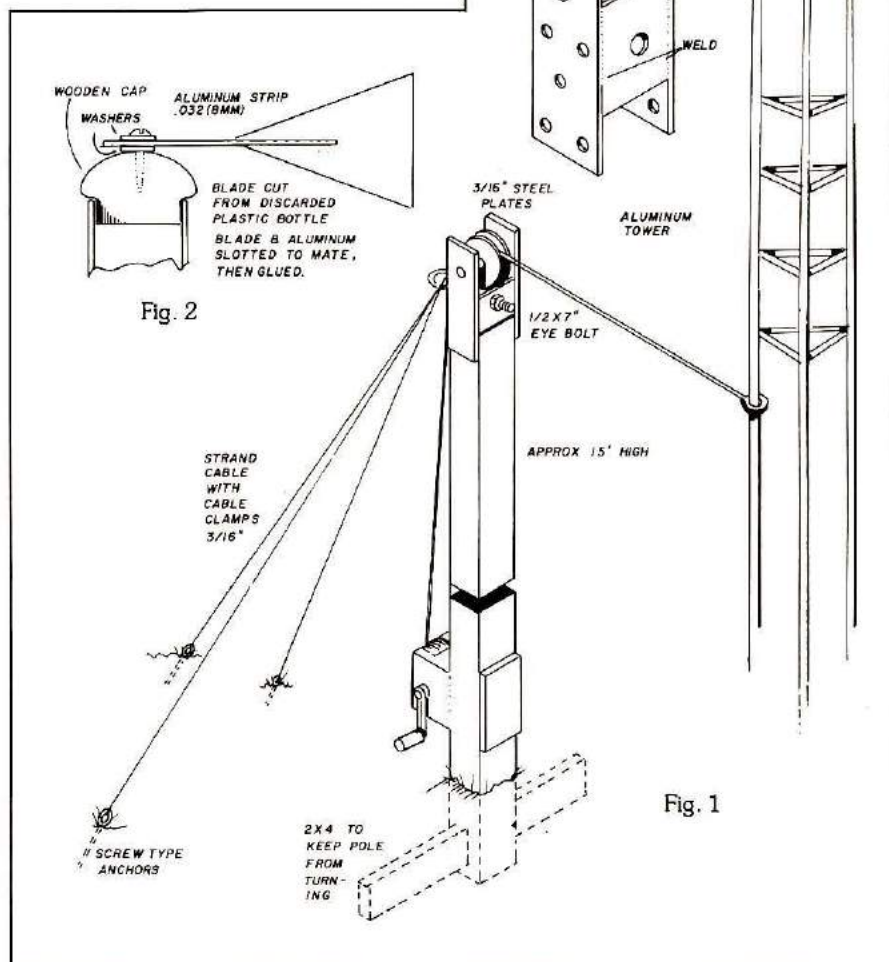

Fig. 1. A permanent gin pole is an asset when you want to work on antennas, try new designs, or lower it for safety during storms. It should be installed within a couple of feet of the base of the tower. The portion of the wooden pole that is in the ground should be treated with a preservative for long life and freedom from insect damage.

Fig. 2. A windvane installed atop the tower will help you determine where best to point the antenna for minimum pressure during high winds.

me. The tower comes down and is raised with just the effort required to turn the crank on the winch. To start it down, the necessary bolts are removed at the base, then a crowbar is used to tip the tower enough so that its weight is on the cable from the winch. The tower is then lowered to be supported on a six-foot ladder. The antenna is now easy to reach and work on. I am able to do the whole

operation alone at anytime the need arises.

While the tower was down this last time, I installed a windvane at the top of the antenna mast so the beam can be oriented broadside to the wind, i.e., the elements parallel with the wind flow (Fig. 2). This seems to put the least stress on the antenna on windy days.

Jack Lo Monaco, WA1YYK

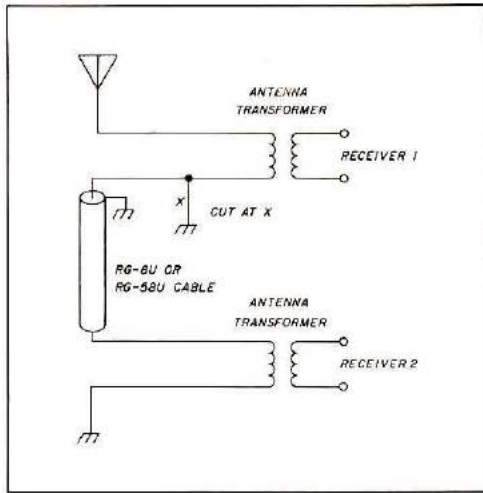

Fig. 1. Two receivers can be made to work from one antenna by connecting their input circuits in series. This will work with receivers that have a transformer at their rf input. If your receivers have simple capacitive coupling at the input, you'll need to make a pair of toroidal transformers and connect them as shown.

Two For One

If the title sounds like poor odds on a tip sheet at Pimlico and not applicable to ham radio, have patience and read on. There have been a number of times in more than thirty-three years as an Amateur when I wished to use more than one receiver on a single antenna system at the same time. Whether corrected directly or through decoupling amplifiers, sensitivity was lost or undesired interaction in the form of rf oscillations resulted.

For use on 2-meter fm I built a quarter-wave ground plane antenna for base-station use. Some months later I obtained a tube-type aeronautical monitor receiver (I'm involved with flying and wanted to listen to the aeronautical service). In the aeronautical communications with which I work, a maximum of three vhf receivers are connected so that the primary side of all the antenna transformers are series connected; the bottom end of the antenna coil in the last receiver is grounded. These are double-conversion, fixed-frequency receivers with a minimum of 1-MHz frequency separation between the three series-connected receivers.

Without a relative signal-strength meter in either the ham or the aeronautical receivers, I not only maintain

my Amateur operation but also copy aeronautical ground station transmitters that I know are putting 10 watts into over 46 meters (150 feet) of RG-8/17, combined. Thus, with about 3 dB power loss in the coaxial cables, I operate both receivers simultaneously. I have more than 20 MHz frequency separation between the receivers. I'm about 32 km (20 miles) airline from the airport.

The only modification to any receiver with a grounded end on the antenna transformer is the addition of a chassis-mounted rf connector such as an SO-239 or a BNC, or N type connector (Fig. 1). The ground connection is lifted and wired to the connector. Then, for single-receiver operation, this point is again restored to ground by a jumper plug of the appropriate type. For dual- or triple-receiver operation, these former ground points are series connected with suitable lengths of 50-ohm coaxial cable. The ungrounded end of the last receiver is grounded once again to re-establish the antenna-circuit continuity. The length of the coax jumpers is somewhat critical for the uhf and vhf ranges for optimum operation but will be less so in the hf range.

Jack Struthers, W2OZY

Code Practice Printout

Since my article, "Code Practice from Your Computer," came out in the November, 1979, *Ham Radio Horizons*, I have received about 120 inquiries from hams who do not have home computers but who wanted to have printouts such as the one illustrated in the article.

Although it was not mentioned in the article, I can supply an extensive printout consisting of 4500 character groups (22,500 characters total) to anyone who is interested. The cost is \$2.50, postpaid, or \$3.00 via air mail to overseas addresses. I've enclosed a sample of an actual printout, below. In this way, people without home computers can try the computer-generated character sets for their code practice. My address is 1808 Pomona Drive, Las Cruces, New Mexico 88001.

William D. Johnston, N5KR

	1	2	3	4	5	6	7	8	9	10	11	12	13
1													
2													
3													
4													
5													
6													
7													
8													
9													
10													
11													
12													
13													

PRODUCT SHOWCASE

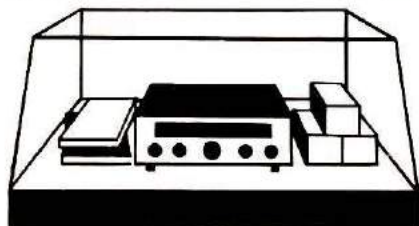

For literature on any of the Product Showcase items use our ad-check service on page 78.

New MFJ 24-Hour Digital Clock



The MFJ-101 is a new 24-hour, solid-state, digital clock. It features pleasant blue, 0.6-inch digits that are easy on the eyes, yet bright enough to see all the way across the room.

The MFJ-101 has an ID timer that alerts you every 9 minutes after you tap the ID/doze button. This 9-minute timer gives you a full minute to identify after the timer sounds and still be legal.

The alarm feature will remind you of that important sked, or wake you in the morning with a pleasant but persistent chirping sound. The fast/slow set buttons make setting time and alarm simple, while the lock function prevents accidental missetting.

The alarm has an indicator which lights up when the alarm is on. If power has been interrupted, the digits flash on and off until the time is reset.

The MFJ-101 is UL approved, and operates on 110 Vac, and can be switched for 50/60 Hz for operation in European and Asian countries.

MFJ provides a 30-day, money-back trial period. If you are not satisfied, you may return it within 30 days for a full refund (less shipping). MFJ also provides a one-year limited warranty.

The MFJ-101 is available from MFJ Enterprises, Inc., for \$29.95 plus \$3.00 shipping and handling.

To order, call toll-free 800-647-1800, or mail order with check or money order to MFJ Enterprises, Inc., P.O. Box 494, Mississippi State, Mississippi 39762.

RF Speech Processors for Drake

The new Sherwood RF speech processors provide no-compromise rf/i-f envelope clipping for high intelligibility and unexcelled talkpower. A specially designed 8-pole i-f crystal filter drives a highly-effective active hard limiter (clipper). Great care has been exercised in developing reliable, ultra-fast, high-isolation pin-diode switching of filters and the clipper stage. Full 8-pole, low-leakage receive and transmit capability is realized. The processors are rig powered, and are easy to interconnect with your equipment. No hole drilling is required.

The 4-SP for the 4-Line transmitters (T-4X, T-4XB, and T-4XC) has separate LSB and USB 8-pole filters of carefully chosen bandwidth for proper filtering ahead of its clipper. The highly versatile 7-SP for the TR-7 not only improves your transmitted signal, but offers automatic transmit/receive switching as well as the option of selecting the processor's special crystal filter for 16-pole, 1.9-kHz receive bandwidth. In addition, circuitry is provided for installing one of the normal accessory filters, such as the SL-500, on the processor board, allowing room for other filters in the TR-7 itself.

All units have filter selection and clipping in/out switches, plus an output control after the clipper (for proper final/PA drive adjustment from band to band, or for precisely setting linear-amplifier excitation level). Clipping is adjusted by the rig microphone-gain control. Each processor is housed in an attractive charcoal-colored cabinet, accented with white lettering, that blends well with all Drake equipment. High-quality machine-screw construction is used (no sheet-metal screws to strip out), with top and bottom removable for easy access to both sides of the PC board.

Model 7-SP for the TR-7 sells for \$265.00, while the 4-SP for the 4-Line transmitters is \$285.00. Others will be available later. Money back if not satisfied. Master Charge and VISA welcome. Please add \$3.00 shipping-handling per order. Overseas airmail \$6.00. Write to Sherwood Engineering, 1268 South Ogden Street, Denver, Colorado 80210.

New "Pro" Antenna Line



Users of two-way radio communications are welcoming the announcement of a new "Professional" line of Antler Antennas. The new Antler "Pro" Antennas include four basic base-loaded models spanning from 30-174 MHz frequencies, plus a "short" quarter-wave, roof-mounted unit tuned to resonate on frequencies between 108 and 174 MHz.

The Professional Antler antennas feature individual testing, and precision electronic tuning of each base coil to ensure efficient, dependable transmissions. The four base-loaded models are for frequencies from 30-36, 36-42, 45-50, and 130-174 MHz. Each antenna is provided with an accurate cutting chart to pinpoint desired frequencies. All coil fittings are precision-machined of chrome-plated, solid brass.

A popular feature of the new Antler line is the buyer's flexibility to order the exact equipment he needs. There are three mounts, including a "no-

hole" trunk-lip mount complete with an attractive, chrome-plated dress cup which hides the attaching clamp. A roof or cowl mount with an easy-to-install snap-in expansion collet is also available, along with Antler's proved "Posi-grip" magnetic mount. Stainless steel shock springs are also available. All mountings include factory-made, low-loss coax cable assemblies.

A handy, short, quarter-wave roof-mount model is also available.

The Antler "Pro" line is distributed nationally through electronic distributors and Amateur Radio dealers. For more information, address Antler Antennas, 6200 South Freeway, Fort Worth, Texas 76134.

One-Step Stripping Tool



Now all wire stripping from sizes 12 to 30 AWG can be done in one step, with one tool! No need for two or more tools to handle different size wires. **The Stripper's** built-in sensor automatically adjusts to cut and strip solid or stranded wire and multiple cable. And, the built-in cutter eliminates the need for still another inconvenient, space-consuming tool. The Stripper feeds from the front, so it can reach anywhere — even into the tightest places. Stainless steel, self-adjusting stripping blades are industrially tough, will stand 100,000 strips or more. This convenient, pocket-sized tool is strong enough to cut and strip as many as six conductors simultaneously in bonded or molded cables! The fiberglass-reinforced nylon body is virtually indestructible and electrically insulated from any shock hazards. Higher productivity, smooth versatility, dependable quality, and the convenience of one-step stripping are yours with the Stripper. For more information on this, and other wire-handling tools by Paladin, write to

Design Marketing, Dept. HH, 5892 Falsey Street, Simi, California 93063. Look for us at the Dayton Hamvention.

Low-cost computerized Morse Keyer from AEA

A new, microprocessor-based Morse keyer — the MK-1 — has been introduced by Advanced Electronic Applications of Lynnwood, Washington.

The MK-1, which incorporates more than twenty special features, will be offered to the CW operator and Amateur market at a special introductory price of \$79.95.

"We're delighted with this new keyer," AEA President Lamb explained. "It represents a major breakthrough in Morse keyers because it offers the advantages of microprocessor digital control at an affordable price."

The MK-1 can easily be programmed to send code at any rate between 2 and 99 wpm with precise full weighting control. The operator can adjust the dot to element space ratio from 0.5:1 to 1.5:1 and the dash to element space ratio from 2.0:1 to 4.0:1.

"The most exciting feature that users comment on is how easy it is to adjust the MK-1 for precise 3:1:1 (dash:dot:space) ratio," Lamb added. "This full weighting feature is not available on other keyers."

Other features incorporated in the MK-1 include: Selectable semi-automatic "bug" mode (also useful for transmitter tuning), automatic stepped sidetone frequency selection, iambic keying with squeeze paddle (paddle not supplied), operates on 9 to 16 volts dc at 200 mA (power supply available for \$9.95 retail), and output for grid-block or transistor circuits.

All control of the computer is performed with a modern keypad mounted on a sloping top surface for no-skid response. All mating connectors are supplied. The MK-1 can be used as a code-practice oscillator with a straight key in the semi-automatic mode. The keyer has outstanding rf immunity.

For more information on the MK-1 and other AEA products including the MorseMatic[®] Memory Keyer, Iso-Pole[®] vertical gain antennas, or Magicom speech processors, contact AEA,

P.O. Box 2160, Lynnwood, Washington 98036; phone (206) 775-7373.

*Trademarks of AEA

Fault Finder Locates Shorts and Opens



The Fault Finder is a solid-state electronic device which, when used in conjunction with a standard clamp-on ammeter, aids in locating shorts or opens in automotive, marine, and aircraft electrical systems, or any other type of electrical system which operates in the range of 5 to 30 volts dc.

Operation is extremely simple. In an automotive electrical system for example, the Fault Finder is clipped into the circuit at the fuse block or at the battery and the clamp-on ammeter gives a direct indication of a short. Any ammeter deflection means a short exists in the circuit. No deflection, no short. Exact location of the short is accomplished by taking readings with the ammeter at various points in the circuit away from the battery or fuseholder. When no current is indicated, the short is known to be between that point and the last point at which current was indicated.

Location of open circuits is accomplished without the use of the ammeter. A puncture clip is provided for this purpose, and a red LED indicator lamp on the Fault Finder gives direct indication of voltage.

The Fault Finder requires no internal battery and comes with a one-year

HAM-KEY™ RADIO TELEGRAPH SENDING DEVICES



Model **HK-3M**
\$19⁹⁵

- * Deluxe straight key
- * Anti-tip bracket. Can't tip
- * Heavy base. No need to attach to desk

CC-3P shielded cable & plug for HK-3M \$2.49.

Add \$.50 Shipping & Handling.

Model AT-B anti-tip bracket only, to convert any HK-3 to HK-3M.
\$2.99 Postpaid

Add \$2.00 Shipping & Handling.

- * Navy type knob
- * Smooth action



Model **HK-1** **\$29⁹⁵**

Add \$2.00 Shipping & Handling.

- * Dual lever squeeze paddle
- * For use with all electronic keyers
- * Heavy base with non-slip rubber feet
- * Paddles reversible for wide or close finger spacing

CC-1P shielded cable & plug for HK-1 \$3.75

Add \$.75 Shipping & Handling.

Model HK-2, same as HK-1 but less base for incorporation in your own keyer. **\$19.95**

Add \$1.00 Shipping & Handling.

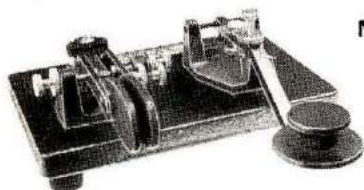

Model **HK-4**
\$44⁹⁵

Add \$2.00 Shipping & Handling.

- * Combination HK-1 & HK-3 on same base
- * Straight key may be used conventionally or as a switch to trigger a memory.

CC-1/3P Shielded cable with plugs for HK-4 \$5.99.

Add \$1.00 Shipping & Handling



Model **HK-5A** Electronic Keyer

\$69⁹⁵

Add \$2.00 Shipping & Handling.

- * Iambic circuit for squeeze keying
- * Self completing dots & dashes
- * Dot & dash memory
- * Built-in sidetone
- * Battery operated with provisions for external power
- * Uses Curtis 8044 keyer chip
- * Grid block or direct keying
- * Speed, volume, tone & weight controls on front panel
- * Use with HK-1 or HK-4

Order direct or from your favorite dealer.

The **HAM-KEY** Co.

P.O. Box 28271 St. Louis, MO 63132

Phone TOLL-FREE 1-800-325-3651



limited warranty at a suggested retail price of \$79.95. A variety of clamp-on ac ammeter models are available at the manufacturer's suggested retail price less 15 per cent. Dealer inquiries welcome.

Contact Paul Brinegar, Trinity Electronics, Inc., 6001 North Michigan Drive, Kansas City, Missouri 64118; phone (816) 452-1045.

New Nine-Band Amateur Transceiver Has New WARC Bands

The new Ten-Tec Delta transceiver is the answer to your wishes and desires — a transceiver capable of covering the new WARC bands at 10, 18, and 25 MHz, packaged in a handsome, small enclosure, and available at an affordable price. Delta is equally at home in the car or at home on SSB or CW, RTTY, or SSTV. Delta has all of the feature you have come to expect from a Ten-Tec transceiver, and more.

It covers 160 through 10 meters in

nine bands; 10.0 to 10.5 MHz band is fully operational on transmit and receive as received. The 18.0 to 18.5 MHz and 24.5 to 25.0 MHz bands are fully incorporated except for accessory plug-in crystals, available when these bands open to Amateurs. Delta has QSK — instant break-in. It is all solid state, and uses basic 13 Vdc circuits. Another Delta feature is wide-band, no-tune final amplifier and receiver front end. Delta has new styling and small size; 4-3/4 x 11-3/8 x 15 inches. The new Model 280 Power Supply comes with over-voltage and over-current protection.

Other features are built-in VOX and PTT, built-in notch filter, hang agc for smooth operation, three selectivity responses to choose from, with optional 500 Hz, six-pole ladder i-f filter for CW. Delta also has a built-in, 20-dB receiver attenuator, excellent receiver dynamic range, and a full line of accessories is available.

For more information and complete specifications, see your nearest Ten-Tec dealer, or write Ten-Tec, Inc., Sevierville, Tennessee 37862.

New Heath 2-kW Antenna Tuner Kit

A new 2-kW antenna tuner in kit form has been introduced by Heath Company, world's largest manufacturer of electronic kits. Featuring a built-in balun, the Heathkit SA-2040 antenna tuner can be used with any type of balanced or unbalanced feed-line. It covers 3.5 to 30 MHz.

Incorporated in the SA-2040's design is a continuously variable inductor said to give an infinite number of impedance settings for precise antenna matching. Inductor settings are indicated by a counter on the front panel. By noting settings on the erasable front panel, the operator can return quickly to a specific frequency. This is especially helpful for net operations or contesting, according to a Heath spokesman.

This antenna tuner features silver-plated straps and roller contact assembly for minimal rf loss at high frequencies. Its large ceramic feed-through insulators are designed to withstand high rf voltage. The tuner is

Upgrade Your CW Easily

DATONG



Model D70 MORSE TUTOR

- Produces random five character groups: all letters, all figures, or mixed.
- Calibrated variable speed (6% to 37 words per minute) and variable delay (up to 3 seconds) between letters for optimum learning efficiency.
- Internal loudspeaker, plus personal ear-piece for private listening. And pocket size.
- Battery operated therefore always ready for use. Current drain is very low for long battery life.
- Eleven IC, CMOS circuit for long internal battery life.
- Built-in tone oscillator for sending practice key required.

\$159.95 Including Pre-Paid Shipping & Full Insurance

Dealer Inquiries Invited
Made in England • 90 Day Warranty
Visa-Mastercharge Accepted

(Exclusive Importers of DATONG FL-1's)

AR Technical Products Corp. Dedicated to Excellence

Box 62
Birmingham, Michigan 48012
Telephone 313/644-5698

capable of handling up to 2000 watts PEP on SSB, and 1000 watts on CW.

The SA-2040 kit includes a detailed Heathkit instruction manual, and can be built in two evenings. Upon completion the antenna tuner can be personalized with the operator's own call sign, using stick-on numerals and letters included with the kit. Housed in a black and gray metal cabinet measuring 5-5/8 x 14-13/16 x 13-15/16, the Heathkit SA-2040 antenna tuner kit sells for \$139.95, F.O.B. Benton Harbor, Michigan 49022.

The SA-2040 antenna tuner, and nearly 400 other electronic kits you build yourself, can be seen at Heathkit Electronic Centers or in the latest Heathkit catalog. A free copy may be obtained by writing Heath Company, Department 350-110, Benton Harbor, Michigan 49022.

Heathkit Electronics Centers are units of Veritechnology Electronics Corporation. Heath Company is a subsidiary of Zenith Radio Corporation.

clipping, and a built-in SSB filter keeps both audio and signal narrow and clean.

The HDP-1220 speech clipper comes fully assembled, and can be installed in just 15 to 30 minutes using only three cables (included). No irreversible modifications need be made to the transceiver or transmitter.

Mail order priced at \$149.95 F.O.B. Benton Harbor, Michigan, the HDP-1220 speech clipper is featured in the latest free Heathkit catalog, along with a complete line of Amateur gear and nearly 400 other electronic kits. For a free copy write: Heath Company, Dept. 350-170, Benton Harbor, Michigan 49022, or visit any of the 54 Heathkit Electronic Centers (Units of Veritechnology Electronics Corporation) nationwide, listed in the telephone directory white pages.

Heath Company is a subsidiary of Zenith Radio Corporation.

Heath Continuing Education Advanced Electronics Programs

Heath Continuing Education, a division of Heath Company, Benton Harbor, Michigan, has introduced a series of three new learn-at-home electronics programs. Each program covers an advanced electronic subject.

All three programs use programmed self-instruction textbooks that present the subject matter in easy, "bite size" segments. They come complete with electronic parts for optional hands-on experiments.

Operational Amplifiers, EE-101, covers the fundamentals of this commonly used integrated circuit family, including the popular Norton and bifet designs. EE-101 is mail order priced at \$39.95.

The Active Filters program, EE-102, covers the design, operation, and uses of active filters. It describes lowpass, highpass, bandpass, and state-variable filters, as well as others. EE-102 sells for \$29.95, mail order.

Heath's Phase-Locked Loops program, EE-104, discusses the uses, designs, and operation of PLLs. Phase-locked loops are widely used in television receivers, FM receivers, CB and 2-meter transceivers, industrial telemetry circuits, and motor controls. EE-

Heath Amateur Radio Speech Clipper



Heath Company, the world's largest manufacturer of electronic kits, has introduced a new, fully-assembled SSB speech clipper for use with a number of its Amateur Radio transceivers and transmitters. The HDP-1220 BW clipper is designed for use with the SB-100/101/102 and HW-100/101 transceivers, and the SB-400/401 transmitters.

The HDP-1220 is said to increase average SSB output by 66 per cent, to a little below key-down CW output. Unlike some speech clippers on the market that connect between microphone and rig, the HDP-1220 installs in the i-f strip of the rig to produce true rf processing. A specially designed IC gives hard, symmetrical

TOWERS by ALUMA

HIGHEST QUALITY ALUMINUM & STEEL

60 Ft. Aluminum.
Crank-Up
Model T-60-H

40' Steel
Crank-Up
Model SHD-40

- ★ TELESCOPING (CRANK UP)
- ★ GUYED (STACK-UP)
- ★ TILT-OVER MODELS

Easy to install. Low Prices.
Crank-ups to 100 ft.

EXCELLENT FOR
HAM COMMUNICATIONS

SPECIAL
Four Section 50 Ft.
Van Mounted Crank-Up
Aluma Tower

Over 36 types aluminum
and steel towers made—
specials designed and
made—write for details

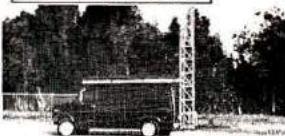

ALUMA TOWER CO.
Box 2806 HH
VERO BEACH, FLA. 32960
PHONE (305) 567-3423
TELEX 80-3405



104 is mail order priced at \$49.95.

All prices are F.O.B., Benton Harbor, Michigan.

For further information on these advanced electronics programs, write for a free catalog to Heath Continuing Education, Dept. 350-160, Benton Harbor, Michigan 49022, or pick up a copy at the nearest Heathkit Electronic Center (Units of Veritechnology Electronics Corporation).

Model 299 Talking Counter

Ten-Tec's Model 299 Talking Counter is a self-contained frequency counter, speech synthesizer, and audio amplifier/speaker system which enhances operating convenience and pleasure for the blind ham operating on the high-frequency bands. It can be used with any high-frequency transceiver, analog or digital, or with any vhf transceiver with an appropriate prescaler. Also, it can be used with any signal generator below 22 MHz as a test instrument. When used with Ten-Tec transceivers employing 9 MHz i-f, special built-in presets allow proper readout of the operating frequency, even though the counter is reading VFO output.

Some operating features are:

Synthesized speech readout of any rf voltage applied to the input between 1 MHz and 22 MHz. This includes the 10-meter band on Ten-Tec transceivers since the VFO operates below 22 MHz.

Choice of MHz and kHz format, or only kHz portion for a quick-repeat cycle.

Choice of one-time or repeat cycling.

Counts to four places after decimal

(100 Hz). When used with analog transceivers, Model 299 increases readout accuracy.

Self-contained audio amplifier and speaker. No need to tap into transceiver audio system.

Only connection required to the transceiver is for the VFO output signal.

Runs on 12 Vdc.

Model 299 Talking Counter user price is \$290.00. For more information, write Ten-Tec, Inc., Sevierville, Tennessee 37862.

Mobile Charger/Amplifier

Trilectric, Inc., Van Nuys, California, announces the introduction of the mobile charger amplifiers for the Wilson Mark series and Yaesu's FT202R 2-meter hand-held transceivers.

The MAC440H and MAC480H respectively have 40- or 90-watt rf power output capability with 4 watts drive. An MC101 charger only is also available. Additional features are a built-in 5-watt audio amplifier for an external speaker, automatic regular or trickle charger, an optional front-panel mounted Touch-Tone® pad which allows generation of DTMF tones while the hand-held is in the case, over or under mounting bracket, for under dash, floor mounting, or base station use, and a key locking feature for portable security.

In addition to mobile operation, the Trilectric MAC440H and MAC480H can be used to allow a hand-held to function as a high-power base station by using a 110 Vac to 13.8 Vdc power supply.

For more information, write to Trilectric, Inc., 6725 DeCellis Place, Van Nuys, California 91406.



New Edition Of Kester Solder Brochure

A new edition of Kester Solder's 12-page brochure covering its broad line of solders and fluxes has been published by the Litton Industries division.



The publication covers acid- and resin-cored solders, flux-cored silver-bearing solders, and radiator solder. Also included are Kester's half-pound spools of acid-core, solid wire, and "44" resin-core solders. Kester's handy package-goods solders, and other carded merchandise are featured too — metal mender, TV-radio solder, aluminum-repair solder, solder-paste flux, and related chemical products.

"Soldering Simplified" and "Questions and Answers about Soldering" are included in the brochure.

Copies are available on request to Mack Haraburd, Vice President, Marketing, Kester Solder, 4201 Wrightwood Ave., Chicago, Illinois 60639.

Heath's New HM-2141 Dual Meter VHF Wattmeter

Heath Company, the world's leading manufacturer of electronic kits, has announced the introduction of a new Dual-Meter VHF Wattmeter for the Radio Amateur. The new HM-2141 monitors both forward and reflected power simultaneously, between 50 and 175 MHz.

the Ultimate 1:1 BALUN

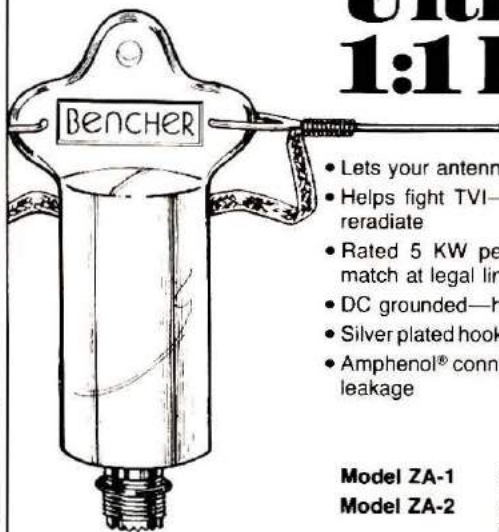

- Lets your antenna radiate—not your coax
- Helps fight TVI—no ferrite core to saturate or reradiate
- Rated 5 KW peak—accepts substantial mismatch at legal limit
- DC grounded—helps protect against lightning
- Silver plated hook-up braid; Custom molded case
- Amphenol® connector; Rubber ring to stop water leakage

Model ZA-1	3.5-30 mHz	\$15.95
Model ZA-2	optimized 14-30 mHz includes hardware for 2" boom	\$17.95

Available at selected dealers, add \$2.00 postage and handling in U.S.A.
WRITE FOR LITERATURE

BENCHER, INC.
333 West Lake Street, Dept A
Chicago, Illinois 60606 (312) 263-1808



According to Heath, the HM-2141 measures forward and reflected average power, forward and reflected peak envelope power (PEP), and standing wave ratio (SWR). The dual-range meter gives simultaneous readings of transmitted output up to 30/300 watts forward, and 10/100 watts reflected power for complete ease of antenna tuning.

Heath specifications give this Dual Meter kit an average forward accuracy of ± 7.5 per cent of full scale. It reads SWR directly from 1:1 to 3:1. The factory-assembled and calibrated sensor can be mounted inside the 4-1/8 x 7-1/2 x 6-3/8 inch cabinet or separately. The HM-2141 can be powered by a 9-volt battery or on 120 Vac using the optional PS-2350 converter. The 9-volt battery is required for PEP operation only.

Mail order priced at \$74.95, F.O.B. Benton Harbor, Michigan, the HM-2141 is featured, along with other Amateur gear and nearly 400 kits you can build yourself, in the latest Heathkit catalog. For a free copy write Heath Company, Department 350-130, Benton Harbor, Michigan 49022. Free catalogs are also available at Heathkit Electronic Centers (Units of Veritechnology Electronics Corporation), listed in your telephone white pages.

Heath is a subsidiary of Zenith Radio Corporation.



"Do you, WJ8IZE take WB7QXY to be your lawfully wed wife..."



Radio World



CENTRAL NEW YORK'S FASTEST GROWING HAM DEALER



Featuring Yaesu, Icom, Drake, Ten-Tec, Swan, DenTron, Midland, KDK, MFJ, Microwave Module, Tempo, Astron, KLM, Hy-Gain, Mosley, Larsen, Cushcraft, Hustler, Mini Products, Bird, DSI, Mirage, Vibroplex, Bencher, Info-Tech, Universal Towers, Callbook, ARRL, Astatic, Shure. We service everything we sell! Write or call for quote. You Won't be Disappointed.

We are just a few minutes off the NYS Thruway (I-90) Exit 32

Warren K2IXN Call Toll Free: 1-800-448-7914
ONEIDA COUNTY AIRPORT TERMINAL BUILDING ORISKANY, NEW YORK 13424
Bob WA2MSH New York State Residents Call: 315-337-2622 or 315-337-0203

CQ Boogie

A brand new novelty record for Amateurs guaranteed to bring you a smile or your money back.

Send \$2.00 to —

RECORD
PO BOX 92
Honeydew,
CA 95545



Digitrex Electronics

PA-19 Wideband Preamp

- 2 to 200 MHz Bandwidth, 3dB Points
- 19 dB Gain!
- 50 Ohms Input & Output Impedance
- Tiny PC Board Size (7/8" x 1-5/8")
- Absolutely No Tuning Required
- Extremely Stable
- Draws only 20mA @ 12VDC
- Great Way to Increase Sensitivity of Receivers, Counters, etc
- Fully Assembled and Tested
- Instructions Provided, Full Warranty

only \$8.95

+ 50 Shipping/Handling

Portable 600 MHz Frequency Counter

- 1-600 MHz Range
- 1 KHz or 100 Hz Resolution
- Assembled and Tested
- Full Lifetime Warranty
- Size 5" L x 2 1/2" W x 1 1/2" H
- BNC Whip Antenna Opt. \$8.95

\$59.95 p.p.d. (less ant.)

C.O.D. Orders Welcome
Digitrex Electronics
4412 Fernlee, Royal Oak
Michigan 48073 313 661 9247

• 75 mV Sensitivity



RATES Regular classified is available at 50¢ per word. Display classified (1 inch deep x 2 1/4 inches wide) is \$65, or at the 12x rate is \$50. All Ad Scan payable in advance. No cash discounts or agency commissions allowed.

HAMFESTS Sponsored by non-profit organizations receive one free regular classified ad (subject to our editing). Repeat insertions of hamfest ads pay the standard rate.

COPY No special layout or arrangements available. Material should be typewritten or clearly printed (not all capitals) and must include full name and address. We reserve the right to reject unsuitable copy. *HORIZONS* cannot check each advertiser and thus cannot be held responsible for claims made. Liability for correctness of material limited to corrected ad in next available issue.

DEADLINE 15th of third preceding month.

SEND MATERIAL TO: Ad Scan, Ham Radio Horizons, Greenville, N. H. 03048.

HAMS FOR CHRIST — Reach other Hams with a Gospel Tract sure to please. Clyde Stanfield, WA6HEG, 1245 Sandra Ct., Upland, Calif. 91766.

WANTED — Military radios and equipment beginning with letters "SS" (example — SSTR-1); also RS-6 radio. Melton, Box 2037, Ogden, Utah 84404; (801) 394-3290.

LEARN CODE THE EASY W6PHA WAY! Former USAF Code Champ gives unique, simple system allowing all ages to learn quickly. Booklet, \$3.00 ppd. Free information with each order offering discounts on Globalman hand keys, code practice oscillators, electronic keyers. Will correspond with booklet purchasers. Global America, 1741-H South Claudina Way, Anaheim, Calif. 92805.

MAKE CODE EASY! Supplement your code program with a self-improvement hypnosis cassette. Tape #3, Learning the Code; Tape #4, Breaking the Speed Barrier. Send \$10.95 each to The John Wolf Self Hypnosis Center, P.O. Box 497, Hayden Lake, Idaho 83835.

SPECIAL SALE: Alliance HD-73 Heavy Duty Rotor \$99.99 plus \$3.00 shipping Continental USA. MC and Visa accepted. Scanner World, USA., 10 New Scotland Ave., Albany, N.Y. 12208. 518-436-9606.

HAM RADIO REPAIR, alignment. Hassle-free from anywhere via UPS. Expert, prompt, reasonable. Modern lab. "Grid" Gridley, W4GJO, Route 2, Box 138B, Rising Fawn, GA 30738.

ICOM INTERNATIONAL USER'S CLUB. Details s.a.s.e. Pohorence, 9600 Kickapoo Pass, Streetsboro, Ohio 44240.

SWL'ERS: DON'T MISS OUT on those rare DX stations. Upgrade your present Antenna System with this new antenna product. \$1 brings complete details, refundable with order. H & S Products, 1706 Magnolia Street, Gardendale, Alabama 35071.

DISTINCTIVE QSL's — Largest selection, lowest prices, top quality photo and completely customized cards. Make your QSL's truly unique at the same cost as a standard card, and get a better return rate! Free samples, catalogue. Stamps appreciated. Stu, K2RPZ, Box 412, Rocky Point, NY 11778, (516) 744-6260.

NOVICES: Improve your skill with eight important operating aids on one 11" x 17" sheet; CW abbreviations, Q-signals, punctuation, U.T.C. conversion and more. \$2. postpaid. WD5KFN, Box 1296, Albany, TX 76430.

QSL's — No stock designs! Your art or ours; photos; originals. 50¢ for samples, details (refundable). Certified Communications, 4138 S. Ferris, Fremont, MI 49412.

CUSTOM EMBROIDERED EMBLEMS — Your design, low minimum. Informational booklet. Emblems, Dept 65, Littleton, New Hampshire 03561.

CB TO 10 METER PROFESSIONALS — Your rig or buy ours — SSB/AM/CW. Certified Communications, 4138 S. Ferris, Fremont, MI 49412. 616-924-4561.

THE MOR-GAIN HD DIPOLES are the most advanced, highest performance multi-band HF dipole antennas available. Patented design provides length one-half of conventional dipoles. 50 ohm feed on all bands, no tuner or balun required. Can be installed as inverted VEE. Thousands in use worldwide. 22 models available including two models engineered for optimum performance for the novice bands. The Mor-Gain HD dipoles N/T series are the only commercial antennas specifically designed to meet the operational requirements of the novice license. Our 1-year warranty is backed by nearly 20 years of HD dipole production experience. Write or call today for our 5-page brochure. (913) 682-3142. Mor-Gain, P.O. Box 329N, Leavenworth, KS 66048.

REWIND JUNK TRANSFORMERS — for any voltage! Manual shows how. \$3.00. Guaranteed. Harrit, Box 495HR, Great Neck, N.Y. 11022.

CODE got you stumped?

RELAX and worry not! Learn international Morse Code the EASY, Rus Farnsworth way. No books, no gimmicks, just listen & learn. Using the word method, based on modern psychological techniques, you can zoom past 13 w.p.m. in **less than half the time!** Available in cassettes @ \$10.95 and LP records at \$9.95 — you get over **two hours** of instruction!

EPSILON RECORDS

P.O. Box 626
San Jacinto, CA 92383

MOBILE HF ANTENNA 3.2 — 30 MHz inclusive, 750 watts PEP, center loaded, tuned from the base, eliminating coil changing or removing from mount. Less than 1.5 to 1 VSWR thru entire coverage. 129.95 ea. plus shipping. Contact your local dealer, if none in your area order direct. Anteck, Inc., Route One, Hansen, Idaho 83334. (208) 423-4100. Master Chg. and VISA accepted. Dealer and factory rep. inquiries invited.

TEN-TEC 262M, 25-Amp, 12-volt, power supply w/meter, exc. \$75; Mirage B-108, 80-watt linear amp w/built-in receiver preamp, \$85; Standard C-118 hand-held w/rubber flex antenna, extra crystals for 144 MHz, w/handmade leather case and t.t. pad, \$100; SEI SPS-30M, 35-amp variable power supply, like new, \$150. Mitchell Rakoff, 64-33 98th Street, Rego Park, N.Y. 11374. (212) 830-0097.

QSLs SECOND TO NONE. Same day service. Samples 50 cents. Include your call for free decal. Ray, K7HLR, Box 331, Clearfield, UT 84015.

MAGAZINE SAMPLES! For a free list of over 135 magazines offering a sample copy, send a stamped, addressed envelope to: Publishers Exchange, P.O. Box 1368, Dept. 26A, Plainfield, NJ 07061.

MOBILE IGNITION SHIELDING provides more range with no noise. Bonding strap sale less than 50¢ each. Literature. Estes Engineering, 930 Marine Drive, Port Angeles, Wash. 98362.

QSL INSURANCE. No more QRL DX operators, managers, or bureaus. New product called "Confirmation Mailer" is your best guarantee in Amateur Radio of receiving a fast direct reply. \$5.50 brings you 30 Policies! Bob Zittnan, K9UJA, P.O. Box 94973, Schaumburg, IL 60193.

QSLs with class! Unbeatable quality, reasonable price. Samples: 50¢ refundable. QSLs Unlimited, 1472 SW 13th Street, Boca Raton, FL 33432.

DX — YOU BET! The DX Bulletin — Best weekly DX info in the world — send for FREE sample copy. The DX Bulletin, 306 Vernon Avenue, Vernon, Connecticut 06066.

QSLs & RUBBER STAMPS — Top Quality! QSLs: Glossy Inks and Cardstock. Rubber Stamps: Report forms, Call Letter, Address, State outlines — More! Stamp Catalog and Card Samples 50¢. Ebbert Graphics 5H, Box 70, Westerville, Ohio 43081.

STOP LOOKING for a good deal on amateur radio equipment — you've found it here — at your amateur radio headquarters in the heart of the Midwest. Now more than ever where you buy is as important as what you buy! We are factory-authorized dealers for Kenwood, Drake, Yaesu, Collins, Wilson, Ten-Tec, Atlas, ICOM, DenTron, MFJ, Tempo, Regency, Hy-Gain, Mosley, Alpha, Cushcraft, Swan and many more. Write or call us today for our low quote and try our personal and friendly Hoosier service. HOOSIER ELECTRONICS, P.O. Box 2001, Terre Haute, Indiana 47802. (812) 238-1456.

HRH LOCATOR

TO HELP YOU FIND YOUR LOCAL AMATEUR RADIO DEALER

Arizona

POWER COMMUNICATIONS

6012 N. 27 AVENUE
PHOENIX, AZ 85017
602-242-6030
Arizona's #1 "Ham" Store,
Kenwood, Yaesu, Drake, ICOM,
& more.

California

JUN'S ELECTRONICS

11656 W. PICO BLVD.
LOS ANGELES, CA 90064
213-477-1824 Trades
714-463-1886 San Diego
The Home of the One Year Warranty
— Parts at Cost — Full Service.

SHAVER RADIO, INC.

1378 S. BASCOM AVE.
SAN JOSE, CA 95128
408-998-1103
Atlas, Kenwood, Yaesu, KDK, Icom,
Tempo, Wilson, Ten-Tec, VHF
Engineering.

TELE-COM

15460 UNION AVENUE
SAN JOSE, CA 95124
408-377-4479

Connecticut

HATRY ELECTRONICS

500 LEDYARD ST. (SOUTH)
HARTFORD, CT 06114
203-527-1881
Connecticut's Oldest Ham
Radio Dealer.

THOMAS COMMUNICATIONS

95 KITTS LANE
NEWINGTON, CT 06111
203-667-0811
Authorized dealer for Kenwood,
Yaesu, Drake, Icom, etc. - CALL US.

Delaware

DELAWARE AMATEUR SUPPLY

71 MEADOW ROAD
NEW CASTLE, DE 19720
302-328-7728
Icom, Ten-Tec, Swan, DenTron,
Wilson, Tempo, KDK, and more.
One mile off I-95, no sales tax.

Florida

AGL ELECTRONICS, INC.

1898 DREW STREET
CLEARWATER, FL 33515
813-461-HAMS
West Coast's Only Full Service
Amateur Radio Store

AMATEUR RADIO CENTER, INC.

2805 N.E. 2ND AVENUE
MIAMI, FL 33137
305-573-8383
The Place For Great Dependable
Names in Ham Radio

RAY'S AMATEUR RADIO

1590 US HWY. 19 SOUTH
CLEARWATER, FL 33516
813-535-1416
Atlas, B&W, Bird, Cushcraft,
DenTron, Drake, Hustler, Hy-Gain,
Icom, K.D.K., Kenwood, MFJ,
Rohn, Swan, Ten-Tec, Wilson.

SUNRISE AMATEUR RADIO

1351 STATE RD. 84
FT. LAUDERDALE, FL 33315
(305) 761-7676
"Best Prices in Country."
Try Us — We'll prove it."

Illinois

AUREUS ELECTRONICS INC.

1415 N. EAGLE STREET
NAPERVILLE, IL 60540
312-420-8629
"Amateur Excellence"

ERICKSON COMMUNICATIONS, INC.

5456 NORTH MILWAUKEE AVE.
CHICAGO, IL 60630
312-631-5181
Outside Illinois 800-621-5802
Hours 9:30-5:30 Mon., Tues., Wed.,
Fri.; 9:30-9:00 Thurs.; 9:00-3:00 Sat.

KLAUS RADIO, INC.

8400 NO. PIONEER PARKWAY
PEORIA, IL 61614
309-691-4840
Let Us Quote Your Amateur Needs.

Iowa

BOB SMITH ELECTRONICS

RFD #3, HIGHWAY 169 & 7
FORT DODGE, IA 50501
515-576-3886
For an EZ deal
800-247-2476/1793
Iowa: 800-362-2371

Kansas

ASSOCIATED RADIO COMM

8012 CONSER
OVERLAND PARK, KS 66204
913-381-5900
America's No. 1 Real Amateur Radio
Store. Trade - Sell - Buy.

Maryland

THE COMM CENTER, INC.

LAUREL PLAZA RT. 198
LAUREL, MD 20810
800-638-4486
Kenwood, Drake, Icom, Ten-Tec,
Tempo, DenTron, Swan
& Apple Computers.

Massachusetts

TEL-COM, INC.

675 GREAT RD., RT. 119
LITTLETON, MA 01460
617-486-3040
The Ham Store of New England
You Can Rely On.

Minnesota

PAL ELECTRONICS INC.

3452 FREMONT AVE. NO.
MINNEAPOLIS, MN 55412
612-521-4662
Midwest's Fastest Growing Ham
Store. Where Service Counts.

New Hampshire

EVANS RADIO, INC.

BOX 893, RT. 3A BOW JUNCTION
CONCORD, NH 03301
603-224-9961
Icom, DenTron, Yaesu, Drake.
We service what we sell.

New Jersey

BARGAIN BROTHERS ELECTRONICS

216 SCOTCH ROAD
GLEN ROC SHOPPING CTR.
WEST TRENTON, NJ 06828
609-883-2050

A million parts — Lowest prices
anywhere. Call us!

BARGAIN BROTHERS II ELECTRONICS

181 HADDON AVENUE
WEST BERLIN, NJ 08091
609-767-5252

Surplus Parts and Equipment
Bought — Sold — Traded.

METUCHEN RADIO

216 MAIN STREET
METUCHEN, NJ 08840
201-494-8350

New and Used Ham Equipment.
WA2AET "T" Bruno

RADIOS UNLIMITED

P. O. BOX 347
1760 EASTON AVENUE
SOMERSET, NJ 08873
201-469-4599

New Jersey's Fastest
Growing Ham Store.

ROUTE ELECTRONICS 46

225 ROUTE 46 WEST
TOTOWA, NJ 07512
201-256-8555

Drake, Swan, DenTron, Cushcraft,
Hy-Gain, Hustler, Larsen and more.

WITTIE ELECTRONICS

384 LAKEVIEW AVE.
CLIFTON, NJ 07011
201-772-2222

Same location for 62 years.
Full-line authorized Drake dealer.

New York

GRAND CENTRAL RADIO

124 EAST 44 STREET
NEW YORK, NY 10017
212-599-2630

Drake, Kenwood, Yaesu, Atlas,
Ten-Tec, Midland, Hy-Gain,
Mosley in stock.

HAM-BONE RADIO

(Div. Stereo Repair Shop)
3206 ERIE BOULEVARD EAST,
SYRACUSE, NY 13214
315-446-2266

We Deal, We Trade,
We Discount, We Please!
2-Way Service Shop on Premises!

HARRISON RADIO CORP.

20 SMITH STREET
FARMINGDALE, NY 11735
516-293-7990

"Ham Headquarters USA®"
since 1925.

Call toll free 800-645-9187.

RADIO WORLD

ONEIDA COUNTY AIRPORT
TERMINAL BLDG.
ORISKANY, NY 13424
800-448-7914

315-337-2622 } NY
315-337-0203 } Res.

New & Used Ham Equipment. See
Warren K2IXN or Bob WA2MSH

Ohio

UNIVERSAL AMATEUR RADIO, INC.

1280 AIDA DRIVE
COLUMBUS (REYNOLDSBURG)
OH 43068

614-866-4267

Complete Amateur Radio Sales and
Service. All major brands - spacious
store - near I-270.

Pennsylvania

HAMTRONICS, DIV. OF

TREVOSE ELECT.
4033 BROWNSVILLE RD.
TREVOSE, PA 19047
215-357-1400

Same Location for
More Than 30 Years.

LaRUE ELECTRONICS

1112 GRANDVIEW STREET
SCRANTON, PENNSYLVANIA 18509
717-343-2124

ICOM, Bird, Cushcraft, CDE,
Ham-Keys, VHF Engineering,
Antenna Specialists.

SPECIALTY COMMUNICATIONS

2523 PEACH STREET
ERIE, PA 16502
814-455-7674

Service, Parts, & Experience
For Your Atlas Radio.

**ELECTRONIC BARGAINS, CLOSEOUTS, SUR-
PLUS!** Parts, equipment, stereo, industrial,
educational. Amazing values! Fascinating items
unavailable in stores or catalogs anywhere.
Unusual FREE catalog. ETCO-059, Box 762,
Plattsburgh, N.Y. 12901.

CALLSIGN PLAQUES. Handsome, professionally
routed and finished with your own station call-
sign. \$14.95. Hamplaques, 10015A Spearfish,
Ellsworth, South Dakota 57706.

DRAKE TWINS: R4B/T4XB recently reworked by
Drake to meet new specs. Sell with matching AC
power supply, speaker, manuals. \$775. WA1YTP,
Sgalia, Box 54 Mad Tom Road, Dorset, VT 05253.
Telephone (802) 362-1912.

ATTENTION: WIRE ANTENNA USERS . . . Now
available . . . a new and unique type Center Con-
nector & Insulators. Use with all types of wire
antennas. \$1 brings full details, refundable with
order. H & S Products, 1706 Magnolia Street,
Gardendale, Alabama 35071.

COMING EVENTS

CALIFORNIA: 1980 Santa Maria Swapfest and
BBQ, Sunday, June 15th. Best steak and biggest
hamfest in the west. Prizes include the Yaesu
FT-707. Swap tables available. QLF and QBK
contests. Tickets \$7 adults, \$3.50 children 6-12.
Write Santa Maria Swapfest, P.O. Box 1615,
Vandenberg AFB, CA 93437 or call KA6AKC (805)
734-1380.

TENNESSEE: HUMBOLDT A.R.C. HAMFEST,
Sunday, May 18th at Shady Acres City Park in
Trenton. Talk-in on 146.37/.97. Flea Market,
Prizes, Ladies' Activities, Light Lunches. More
information from Ed Holmes, WA4IGW, 501 North
18th Avenue, Humboldt, Tennessee 38343.

RADIO EXPO "80" — Lake County Fair
Grounds, Rt. 45 & 120. September 6 and 7. Ad-
vance tickets \$2.00, \$3.00 at gate. Write Radio
Expo Tickets, P.O. Box 1532, Evanston, IL 60204.
Exhibitor information call (312) BST-EXPO.

ONTARIO: Lake Simcoe Hamfest, June 13th,
14th and 15th, at Molson's Park, Barrie, Ontario,
Canada. Registration: \$4 by mail, \$5 at gate.
Children under 18 admitted free. Doors open at
12:00 noon on Friday the 13th, with talk-in on
VE3LSR 146.25/.85 and 146.52 simplex, or 3780
kHz SSB. For information, reservations, or
tickets, write to Lake Simcoe Hamfest, P.O. Box
2283, Orillia, Ontario L3V 6S1, Canada.

FLORIDA: Daytona Beach ARA Family Funfest,
May 31st and June 1st, at the Desert Inn, 900
North Atlantic Avenue, Daytona Beach, Florida.
Commercial exhibits, swap tables, forums, door
prizes, ladies' activities, auction. Admission \$3
advance, \$4 at door. Tables \$8 each for both
days. Rooms \$25.44 single, \$29.68 double, tax
included. Write or call Dave Rusler, WA4ZTT,
1725 Hope Drive, Ormond Beach, Florida 32074;
telephone (904) 672-9536.



A FLEA GROWS IN HAMERICA!
YES, A NATIONAL MARKET PLACE
FOR DEALINGS IN USED GEAR.

1879 POST RD., P.O. BOX 66, SOUTHPORT, CT 06490

HGM matches Buyers with Owners of used equipment. Perfectly! Register gear you want to sell or buy, nationally, for only \$3.73. At least once a week, HGM compares Buyer specifications to all available equipment registered by Owners. For each perfect match, HGM writes Buyers the particulars about the gear. Buyers contact Owners directly, and all negotiations are strictly between Owners and Buyers.

HGM GUARANTEE. Just \$3.73 per registration (a "sell" or a "buy"), and your Registration remains active for 17 unique matchings or 17 months. No HGM commissions! We cannot warrant nor guarantee any equipment found through HGM since everything is between Owners and Buyers. But we do guarantee unique matchings and 17 matchings or months. A fabulous service for the amateur service!

REGISTER NOW. Use this form or facsimile and enclose the \$3.73 fee for each Registration. OWNERS: Describe unit by Type, Brand, and Model. Indicate exact Sell Price and purchase data. BUYERS have two choices: Choice #1: Type of Gear, Indicate Type and one Price Range. Example: Transceiver, \$700-899. Choice #2: Specific Unit, regardless of price. Indicate specific Brand and Model you want. Example: Transceiver, Ten-Tec, Century 21.

YES, hamgearmart, I need your help! I understand your Guarantee, and I'm enclosing \$3.73 with this Registration. Enter my Registration immediately.

Please register me as a . . .

OWNER **BUYER**

SELL PRICE	TYPE OF GEAR	PRICE RANGES
GEAR YEAR	XCVR. SCOPE, ETC.	A. 40 - 99
PURCHASED	BRAND NAME	B. 100 - 199
NEW/USED	MODEL NUMBER	C. 200 - 299
		D. 300 - 399
		E. 400 - 524
		F. 525 - 699
		G. 700 - 899
		H. 900 - 1099
		I. 1100 - 1399
		J. 1400 AND UP

NAME	CALL	CLASS
ADDRESS	TELEPHONE	
CITY	STATE	ZIP
hamgearmart 1879 Post Road, P.O. Box 66 Southport, Connecticut 06490		

21 MHz SSB-CW PLL DIGITAL TRANSCEIVER

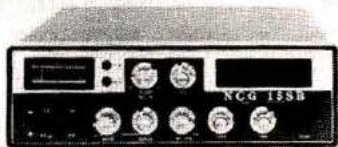

NCG-15-SB

SPECIFICATIONS:

- **Frequency Range:** 21.000-21.495 MHz \pm VXO adj. • **VXO Range:** Approx \pm 5 kHz from display • **Sweep Scan Range:** Same as VXO • **Power Output:** 15W (PEP) nominal max. • **Spurious Radiation:** Down 60 dB or more • **Carrier Suppression:** 40 dB or more, CW or SSB • **RX Sensitivity:** 0.5 μ V or better for 10 dB S/N • **RX Selectivity:** 2.2 kHz at 6 dB; 4.6 kHz, 50 dB • **Image Rejection:** 60 dB or more • **RX Spurious Response:** Down 50 dB or more • **Power Required:** 13.8 VDC, 2.5 A (peak) XMIT, & positive or negative ground • **Modulation:** USB (Suppressed Carrier) or CW

FEATURES:

- Active noise blanker • Squelch • RX RF gain control • 5 digit frequency display • CW sidetone • Transmit ALC & HI/LO power switch

A fine Novice/Tech Base & General/Adv/Extra Mobile

Call or write for price
Dealer Inquiries Invited

NCG COMPANIES

1275 NORTH GROVE ST., ANAHEIM, CA 92806
(714) 630-4541

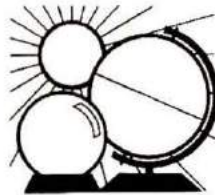

DX FORECASTER

Last-minute predictions

May appears to be another relatively quiet month with regard to potentially major ionosphere or geomagnetic field upsets. You may expect a possible minor upset between the 5th and 8th, a somewhat more vigorous perturbation around the 14th, another mild one about the 22nd, and finally an upset on or about the 30th. Most of these will be in the nature of geomagnetic-field disturbances ranging from quiet to unsettled, except possibly around the 14th when the field could be unsettled to active. DX propagation conditions appear to be favorable at other times, but the springtime activity is slowly giving way to the summertime doldrums in the HF spectrum. VHF meteor-burst propagation between the 3rd and 5th ought to be quite good. For the first time in four or five years, the sunspot cycle is declining — even if slowly — so HF activity will decline as well, leading to lowered MUFs. Hence, fall DX activity may not be as good as it was a year ago, or even this month.

Band-by-band summary

Six meters is not generally considered to be a summertime DX band, but occasional openings will occur. Short skip openings from sporadic E propagation, together with DX propagation due to F2 layer activity will keep life interesting. The best times to look for DX will be when ten meters is peaking strongly, and in the same direction.

Ten meters offers excellent DX into South and Central America, parts of Africa, and the Pacific. Band conditions will peak during the afternoon when strongest signals will prevail, but look at other times as well, as DX follows the sun westward. May is a transition month between the somewhat poorer summertime conditions and the excellent DX propagation that accompanies the spring equinox.

Fifteen meters will be open during daylight hours, and good worldwide

propagation can be expected on most days of the month. Band conditions will peak during the late afternoon hours, and you will often find loud short-skip signals interspersed with DX signals. The band ought to remain open until dark on most days, as short skip signals blend with those from the Pacific.

Twenty meters will offer good DX conditions around the clock, with the peak occurring shortly after sunrise, and again during the late afternoon and evening hours. During the morning the band usually opens up to the east, following the sun westward during the day, and terminating in the far Pacific in the late evening. Short-skip signals will be prevalent during the day from about 350 miles (600 km) to 2300 miles (4000 km) and, during the evening, from about 1000 to 2300 miles.

Forty meters is expected to provide good DX from about sunset through the hours of darkness until about sunrise. The chart will help you determine directions and times, but with the onset of atmospheric static from thunderstorm activity, weak signals may be masked by the QRN. Daytime short skip distances to 750 miles (1250 km) should be common, but after dark the band really opens out to distances up to 2500 miles (4000 km). During this early-summer season, forty will not be quite as lively for DX as it was in winter, but it will still be good.

Eighty meters will provide some opportunities for DX during the darkness hours, and again at sunrise, but conditions will be substantially poorer than during the winter. High atmospheric noise levels, and generally weaker signals will combine to frustrate all but the most diligent and persevering hams.

One-sixty meters is considered to be hopeless during the daytime because of the high absorption levels and the static, which combine to prevent communication on this interesting band. Occasionally, the band will open up during the evening when QRN levels are low, permitting two-way communication out to distances of about 1000 miles (1600 km). Most serious DXers leave 160 to the ragchewers during the summer months.

HRH

WESTERN USA

MID USA

EASTERN USA

GMT	WESTERN USA										MID USA										EASTERN USA																
	ASIA	FAREAST	EUROPE	S. AFRICA	S. AMERICA	ANTARCTICA	NEW ZEALAND	OCEANIA	AUSTRALIA	JAPAN	ASIA	FAREAST	EUROPE	S. AFRICA	S. AMERICA	ANTARCTICA	NEW ZEALAND	OCEANIA	AUSTRALIA	JAPAN	ASIA	FAREAST	EUROPE	S. AFRICA	S. AMERICA	ANTARCTICA	NEW ZEALAND	OCEANIA	AUSTRALIA	JAPAN							
PDT	N	NE	E	SE	S	SW	W	NW		N	NE	E	SE	S	SW	W	NW		N	NE	E	SE	S	SW	W	NW		N	NE	E	SE	S	SW	W	NW		
0000	5:00	—	15	—	10	15	10	15	15	15	—	20	—	10	15	15	15	15	—	—	20	—	10	15	20*	15	15	—	15	20	—	10	15	15	15	—	
0100	6:00	—	20	—	15	15	10	15	15	15	—	20	—	15	20*	15	15	15	15	—	—	20	—	15	20*	15	15	—	15	20	—	15	20	15	15	—	
0200	7:00	—	20	20	15	15	10	15	15	15	—	20	—	15	20*	15	15	15	15	—	—	20	—	15	20*	15	15	—	15	20*	15	20	15	20*	15	—	
0300	8:00	—	20	20	20	15	10	15	15	15	—	20	—	15	20*	15	15	15	15	20	—	—	20	—	15	20*	15	15	—	15	20*	15	20	15	20*	15	—
0400	9:00	—	20	20	20	15	15	15	15	15	—	20	—	20	20	15	15	15	15	20	—	—	20	—	20	20*	15	15	—	20	20*	15	20	15	20*	15	—
0500	10:00	—	20	20	20	20	15	15	15	15	—	20	—	20	20	15	15	15	15	20	—	—	20	—	20	20*	15	15	—	20	20*	15	20	15	20*	15	—
0600	11:00	—	20	20	20	20	20	20	20	20	—	20	—	20	20	20	20	20	20	20	—	—	20	—	20	20	20	20	—	20	20	20	20	20	20	20	—
0700	12:00	—	20	—	20	20	20	20	20	20	—	20	—	20	20	20	20	20	20	20	—	—	20	—	20	20	20	20	—	20	20	20	20	20	20	20	—
0800	1:00	20	—	—	20	20	20	20	20	20	—	20	—	—	20	20	20	20	20	20	—	—	20	—	20	20	20	—	20	20	20	20	20	20	20	—	
0900	2:00	20	—	—	20	20	20	20	20	20	—	20	—	—	20	20	20	20	20	20	—	—	20	—	20	20	20	—	20	20	20	20	20	20	20	—	
1000	3:00	20	—	—	20	20	20	20	20	20	—	20	—	—	20	20	20	20	20	20	—	—	20	—	20	20	20	—	20	20	20	20	20	20	20	—	
1100	4:00	20	—	—	20	20	20	20	20	20	—	20	—	—	20	20	20	20	20	20	—	—	20	—	20	20	20	—	20	20	20	20	20	20	20	—	
1200	5:00	20	—	—	20	20	20	20	20	20	—	20	—	—	20	20	20	20	20	20	—	—	20	—	20	20	20	—	20	20	20	20	20	20	20	—	
1300	6:00	20	20	—	20	20	20	20	20	20	—	20	—	—	20	20	20	20	20	20	—	—	20	—	20	20	20	—	20	20	20	20	20	20	20	—	
1400	7:00	20	20	20	20	20	20	20	20	20	—	20	—	—	20	20	20	20	20	20	—	—	20	—	20	20	20	—	20	20	20	20	20	20	20	—	
1500	8:00	20	20	20	20	20	20	20	20	20	—	20	—	—	20	20	20	20	20	20	—	—	20	—	20	20	20	—	20	20	20	20	20	20	20	—	
1600	9:00	15	15	20	20	20	—	—	—	—	20	—	—	—	—	—	—	—	—	—	—	—	—	—	—	—	—	—	—	—	—	—	—	—	—	—	
1700	10:00	15	15	15	20	—	—	—	—	—	15	—	—	—	—	—	—	—	—	—	—	—	—	—	—	—	—	—	—	—	—	—	—	—	—	—	
1800	11:00	15	15	15	10	—	—	—	—	—	15	—	—	—	—	—	—	—	—	—	—	—	—	—	—	—	—	—	—	—	—	—	—	—	—	—	
1900	12:00	15	—	15	10	—	—	—	—	—	15	—	—	—	—	—	—	—	—	—	—	—	—	—	—	—	—	—	—	—	—	—	—	—	—	—	
2000	1:00	15	—	—	10	—	—	—	—	—	15	—	—	—	—	—	—	—	—	—	—	—	—	—	—	—	—	—	—	—	—	—	—	—	—	—	
2100	2:00	—	—	—	15	—	15	15	15	15	—	—	—	—	—	—	—	—	—	—	—	—	—	—	—	—	—	—	—	—	—	—	—	—	—	—	
2200	3:00	—	15	—	10	—	—	—	—	—	—	—	—	—	—	—	—	—	—	—	—	—	—	—	—	—	—	—	—	—	—	—	—	—	—	—	
2300	4:00	—	15	—	10	—	—	—	—	—	—	—	—	—	—	—	—	—	—	—	—	—	—	—	—	—	—	—	—	—	—	—	—	—	—	—	

Sunday	Monday	Tuesday	Wednesday	Thursday	Friday	Saturday
<p>Fourth Annual Bristol County Amateur Radio Association Flea Market and Radio Auction - Knights of Columbus Hall, Fall River, Massachusetts - 9AM to 5PM, EST - AA1Q - 4</p> <p>Tri-County Radio Association's Annual Hamfest/Flea Market - Passaic Township Youth Center, Stirling, New Jersey - 9AM to 4PM, EST - W2CHA - 4</p> <p>The Vermont Amateur Radio Club's Sixth Annual Ham-Mart - Vermont Technical College, High School, Ferrisburgh, Starks Co., Ferrisburgh, Vermont, Vt. - 9AM to 4PM, EST - W2GBO - 4</p> <p>Eighth Annual Sacramento Valley Amateur Radio Ham Swap - Mechanics Hall 3081, Sunrise Blvd., Rancho Cordova - 9AM to 3PM, PST - K6IS - 4</p>	<p>The Newport Radio Club's Auction - Club Headquarters at the Steamers Institute, Newport, Rhode Island - 7PM, EST - 5</p> <p>Glenhurst Radio Society Transmits Amateur Radio News - 222.65/224.26 MHz via WR2APG and 21.400 MHz USB</p>	<p>AMSAT Eastcoast Net 3850 kHz 9:00 PM, EDST (01100Z Wednesday Morning)</p> <p>AMSAT Mid-Continent Net 3850 kHz 9:00 PM, CDST (0200Z Wednesday Morning)</p> <p>AMSAT Westcoast Net 3850 kHz 8:00 PM, PDST (0310Z Wednesday Morning)</p>			<p>Hampden County Radio Association's Annual Flea Market - Feeding Hills Congregational Church, Feeding Hills, Massachusetts - 7PM, EST - WB1BZW - 2</p>	<p>Twenty-first Annual Southern Tier A.R.C. Hamfest - Oswego Treadway Inn, Oswego, New York - 3</p>
<p>Rocky Mountain Division QSO Party - Asaphole Radio Club, Linton, Colorado - 1800Z Saturday to 2400Z Sunday - KAWCLS - 10-11</p> <p>Georgia QSO Party - Sponsored by the Atlanta Radio Club, Inc. - 1600 GMT May 10 to 0200 GMT May 12 - W4DQPT - 10-12</p>	<p>Florida Ham News - Swap Net By the Broadcast ARC 146.31-91 at 7:30 PM</p> <p>Glenhurst Radio Society Transmits Amateur Radio News - 222.65/224.26 MHz via WR2APG and 21.400 MHz USB</p> <p>West Coast Bulletin Edited & Transmitted by W6ZF 8:00 PM PST 3540 kHz, A-1, 22 WPM</p>	<p>AMSAT Eastcoast Net 3850 kHz 9:00 PM, EDST (01100Z Wednesday Morning)</p> <p>AMSAT Mid-Continent Net 3850 kHz 9:00 PM, CDST (0200Z Wednesday Morning)</p> <p>AMSAT Westcoast Net 3850 kHz 8:00 PM, PDST (0300Z Wednesday Morning)</p>			<p>Ford Tin Lizzy Club, North Metro Chapter's Second Annual "Tip-of-the-Thumb" Expedition - Point Aux Barques Resid., Michigan - 7:275 and 21.380 MHz - A18K - 16</p>	<p>1980 Florida QSO Party, Sponsored by Florida Skip - 1500 UTC May 17 to 2359 UTC May 18 - W4MNZ - 17-18</p> <p>1980 Michigan QSO Party, Sponsored by the Oak Park Amateur Radio Club - 1800 May 17 to 0300 May 18 and 1100 May 18 to 0200 May 19 - K8ED - 17-19</p> <p>Dogwood Festival QSO Party, Sponsored by the Greater Fairfield Amateur Radio Association - Club Call WB1CQQ - 1300-2200 UTC May 17 - W1HEO - 17</p> <p>The 1980 Massachusetts QSO Party, Sponsored by The Greater New Bedford Contesters - 1600 GMT May 17 to 0200 GMT May 19 - K1KJT - 17-19</p>
<p>Sixth Annual Eastern Amateur Radio Society Hamfest - Easton Senior High School, Easton, Maryland - 10AM to 4PM, EST - K43BRW - 18</p> <p>Annual Humboldt ARC Hamfest - Shady Acres City Park, Trenton, Tennessee - W6JGW - 18</p> <p>Webbush County ARC Hamfest - 4H Fairgrounds, Wabash, Indiana - 6AM - N9ADQ - 18</p> <p>Yakima Amateur Radio Club's (W7AQ) Hamfest - Yakima, Washington - K4YDWH - 18</p> <p>Long Island Mobile Amateur Radio Club Inc.'s ARRL Hamfest '80 - Long Beach, Long Beach, Long Island - 9AM to 4PM, EST - WB2ZALW - 18</p>	<p>The Law West of the Pecos Fun DX-Pedition (W5TEX) - 1800 GMT Saturday to 1800 GMT Sunday - W5JQM - 19-20</p> <p>Glenhurst Radio Society Transmits Amateur Radio News - 222.65/224.26 MHz via WR2APG and 21.400 MHz USB</p>	<p>AMSAT Eastcoast Net 3850 kHz 9:00 PM, EDST (01100Z Wednesday Morning)</p> <p>AMSAT Mid-Continent Net 3850 kHz 9:00 PM, CDST (0200Z Wednesday Morning)</p> <p>AMSAT Westcoast Net 3850 kHz 8:00 PM, PDST (0300Z Wednesday Morning)</p>				<p>Maryland F.M. Association's Hamfest - Greenbelt Armory, Greenbelt, Maryland - 8AM to 4PM, EST - K3PNI - 24</p> <p>Holliston Amateur Radio Club Tenth Anniversary QSO Party - 1100 UTC May 24 to 1900 UTC May 24, 2300 UTC May 24 to 0700 UTC May 25, 1500 UTC May 25 to 2359 UTC May 25 - N4BP - 24-25</p> <p>Amateur Radio and Computer Hobbyists Second Annual Convention - Cervantes Convention Center, St. Louis, Missouri - 24-25</p>
<p>Third Annual Sandusky Valley Amateur Radio Club Hamfest - Sandusky County Fairgrounds, Fremont, Ohio - 9AM, EST - WB9NMA - 25</p> <p>Second Annual Reading Radio Club Hamfest - Hamburg, Pennsylvania Fieldhouse - W3BN - 25</p> <p>Daytona Beach Amateur Radio Association's Second Annual Daytona Beach Family Hamfest - Deert Inn, Daytona Beach, Florida - W4KZTT - 31-June 1</p>	<p>Florida Ham News - Swap Net By the Broadcast ARC 146.31-91 at 7:30 PM</p> <p>Glenhurst Radio Society Transmits Amateur Radio News - 222.65/224.26 MHz via WR2APG and 21.400 MHz USB</p> <p>West Coast Bulletin Edited & Transmitted by W6ZF 8:00 PM PST 3540 kHz, A-1, 22 WPM</p>	<p>AMSAT Eastcoast Net 3850 kHz 9:00 PM, EDST (01100Z Wednesday Morning)</p> <p>AMSAT Mid-Continent Net 3850 kHz 9:00 PM, CDST (0200Z Wednesday Morning)</p> <p>AMSAT Westcoast Net 3850 kHz 8:00 PM, PDST (0300Z Wednesday Morning)</p>				<p>1980 Florida QSO Party, Sponsored by Florida Skip - 1500 UTC May 17 to 2359 UTC May 18 - W4MNZ - 17-18</p> <p>1980 Michigan QSO Party, Sponsored by the Oak Park Amateur Radio Club - 1800 May 17 to 0300 May 18 and 1100 May 18 to 0200 May 19 - K8ED - 17-19</p> <p>Dogwood Festival QSO Party, Sponsored by the Greater Fairfield Amateur Radio Association - Club Call WB1CQQ - 1300-2200 UTC May 17 - W1HEO - 17</p> <p>The 1980 Massachusetts QSO Party, Sponsored by The Greater New Bedford Contesters - 1600 GMT May 17 to 0200 GMT May 19 - K1KJT - 17-19</p>
<p>Sixth Annual Eastern Amateur Radio Society Hamfest - Easton Senior High School, Easton, Maryland - 10AM to 4PM, EST - K43BRW - 18</p> <p>Annual Humboldt ARC Hamfest - Shady Acres City Park, Trenton, Tennessee - W6JGW - 18</p> <p>Webbush County ARC Hamfest - 4H Fairgrounds, Wabash, Indiana - 6AM - N9ADQ - 18</p> <p>Yakima Amateur Radio Club's (W7AQ) Hamfest - Yakima, Washington - K4YDWH - 18</p> <p>Long Island Mobile Amateur Radio Club Inc.'s ARRL Hamfest '80 - Long Beach, Long Beach, Long Island - 9AM to 4PM, EST - WB2ZALW - 18</p>	<p>The Law West of the Pecos Fun DX-Pedition (W5TEX) - 1800 GMT Saturday to 1800 GMT Sunday - W5JQM - 19-20</p> <p>Glenhurst Radio Society Transmits Amateur Radio News - 222.65/224.26 MHz via WR2APG and 21.400 MHz USB</p>	<p>AMSAT Eastcoast Net 3850 kHz 9:00 PM, EDST (01100Z Wednesday Morning)</p> <p>AMSAT Mid-Continent Net 3850 kHz 9:00 PM, CDST (0200Z Wednesday Morning)</p> <p>AMSAT Westcoast Net 3850 kHz 8:00 PM, PDST (0300Z Wednesday Morning)</p>				<p>Maryland F.M. Association's Hamfest - Greenbelt Armory, Greenbelt, Maryland - 8AM to 4PM, EST - K3PNI - 24</p> <p>Holliston Amateur Radio Club Tenth Anniversary QSO Party - 1100 UTC May 24 to 1900 UTC May 24, 2300 UTC May 24 to 0700 UTC May 25, 1500 UTC May 25 to 2359 UTC May 25 - N4BP - 24-25</p> <p>Amateur Radio and Computer Hobbyists Second Annual Convention - Cervantes Convention Center, St. Louis, Missouri - 24-25</p>
<p>Third Annual Sandusky Valley Amateur Radio Club Hamfest - Sandusky County Fairgrounds, Fremont, Ohio - 9AM, EST - WB9NMA - 25</p> <p>Second Annual Reading Radio Club Hamfest - Hamburg, Pennsylvania Fieldhouse - W3BN - 25</p> <p>Daytona Beach Amateur Radio Association's Second Annual Daytona Beach Family Hamfest - Deert Inn, Daytona Beach, Florida - W4KZTT - 31-June 1</p>	<p>Florida Ham News - Swap Net By the Broadcast ARC 146.31-91 at 7:30 PM</p> <p>Glenhurst Radio Society Transmits Amateur Radio News - 222.65/224.26 MHz via WR2APG and 21.400 MHz USB</p> <p>West Coast Bulletin Edited & Transmitted by W6ZF 8:00 PM PST 3540 kHz, A-1, 22 WPM</p>	<p>AMSAT Eastcoast Net 3850 kHz 9:00 PM, EDST (01100Z Wednesday Morning)</p> <p>AMSAT Mid-Continent Net 3850 kHz 9:00 PM, CDST (0200Z Wednesday Morning)</p> <p>AMSAT Westcoast Net 3850 kHz 8:00 PM, PDST (0300Z Wednesday Morning)</p>				<p>1980 Florida QSO Party, Sponsored by Florida Skip - 1500 UTC May 17 to 2359 UTC May 18 - W4MNZ - 17-18</p> <p>1980 Michigan QSO Party, Sponsored by the Oak Park Amateur Radio Club - 1800 May 17 to 0300 May 18 and 1100 May 18 to 0200 May 19 - K8ED - 17-19</p> <p>Dogwood Festival QSO Party, Sponsored by the Greater Fairfield Amateur Radio Association - Club Call WB1CQQ - 1300-2200 UTC May 17 - W1HEO - 17</p> <p>The 1980 Massachusetts QSO Party, Sponsored by The Greater New Bedford Contesters - 1600 GMT May 17 to 0200 GMT May 19 - K1KJT - 17-19</p>

**not just another
PRETTY FACE..**



KLM **POWER AMPLIFIERS**

**RUGGED & RELIABLE INSIDE,
WHERE IT REALLY COUNTS!**

- OVER TEMP PROTECTION
- VSWR PROTECTION
- REVERSE POLARITY PROTECTION
- ALL MODELS EXCEED FCC SPEC'S LIMITING HARMONIC AND SPURIOUS EMISSIONS
- ONE YEAR WARRANTY

A FULL SPECTRUM of MODELS

FOR 2 Meters, 220 & 432 MHz

■ SEE YOUR LOCAL DEALER
OR CONTACT:

KLM electronics, inc. 17025 LAUREL ROAD, MORGAN HILL, CALIFORNIA 95037 (408) 779-7353

AD CHECK

... for literature, in a hurry — we'll rush your name to the companies whose names you check.

Place your check mark in the space between name and number. Example: HRH 150.

INDEX

AR Tech. ___ 687	Long's ___ 468
A. E. A. ___ 677	MFJ ___ 082
Aluma ___ 589	Madison ___ 431
Antenna Supermarket *	Microcraft ___ 774
Antler	Microwave Filter ___ 637
Antennas ___ 547	NCG ___ 829
Barry *	Oak Hill Academy A. R. S. *
Bencher ___ 629	Palomar Eng. *
DSI ___ 656	Panasonic ___ 683
Design Marketing *	RSE Ham Shack ___ 607
Digitrex ___ 823	Callbook ___ 100
E. T. O. *	Constructor *
Hal *	Radio World *
Ham Gear Mart *	Record *
HRB ___ 150	S-F A. R. S. ___ 640
HORIZONS *	Sherwood Eng. ___ 435
Heath ___ 060	Slep ___ 232
Hustler ___ 171	Ten-Tec *
Icom *	Ham Key Co. *
KLM ___ 073	Trilectric ___ 833
Kantronics *	Trinity Elec. *
Kenwood *	Van Gorden ___ 737
Kester Solder ___ 492	Wilson Sys. ___ 787
Larsen ___ 078	

*Please contact this advertiser directly.

Limit 15 inquiries per request.

MAY 1980

Please use before June 30, 1980

Tear off and mail to
HAM RADIO HORIZONS — "Ad Check"
Greenville, N. H. 03048

NAME _____

CALL _____

STREET _____

CITY _____

STATE _____ ZIP _____

MAY MADNESS

ALPHA 76, 374, 78 In Stock.....	Call
Cushcraft "boomer".....	69.95
OMNI-J 2 Meter Antenna.....	39.95
Bird 43 and slugs, UPS paid in USA....	stock
Microwave Modules, Less 10% off list, stock	
Telrex TB5EM, in stock.....	415.00
TB6EM.....	520.00
Monobanders in stock	
New Telrex TB5ES, 2KW Pep version.....	315.00
New Palomar Transceiver Preamp....	89.50
Bencher Paddles.....	39.95
	chrome... 49.95
Vibroplex Paddles in stock, & bugs... call	
Lunar 6M-2M-220 In-line Preamps.....	stock
Janel QSA-5.....	41.95
HAM-X Tailtwister Rotor.....	189.00
HAM-4 Rotor.....	139.00
Cetron or GE 572B.....	32.00/ea
GE. AMPGREX, Raytheon G146B....	9.95
Motorola HEP170.....	0.29
Mallory 2.5A/1000 PIV Epoxy diode....	0.19
Sprague 100MFD/450VDC Cap.....	2.00
Aerovox 1000PF/500V Feedthru Cap....	1.95
Adel Nibbling Tool.....	8.45
Technical books: Ameco, ARRL, Sams, TAB, Rider, Radio Pub., Callbook, Cowan, WRTVH, etc. Call	
New Belden 9405 (2#16)(6#18) 8 wire	
Rotor cable, heavy duty for long runs.	0.32/ft
8448 8 wire Rotor Cable.....	0.20/ft
9888 Double Shield RG8 Foam.....	0.46/ft
8214 RG8 Foam.....	0.26/ft
8237 RG8 Regular.....	0.23/ft
8267 RG213.....	0.30/ft
9251 RG8 A/U.....	0.35/ft
Belden #8000 14GA	
Stranded Antenna wire.....	0.06/ft
Amphenol Silverplate PL259 (8315P)....	0.69
Berktex RG8X 52ohm, KW.....	0.16/ft
Robot "Slow Scan" 400.....	499.00

Telrex antennas?
In Stock!

Monobanders?
You bet!

Looking for antique parts?
Write specific need to W5GJ.

THIS MONTH'S SPECIALS:

New IC701, AC, MIC \$1195.00;
New ICOM, IC251A — 2M \$599.00;
IC551D 6M-100W \$599.00.
IC551 \$399.00.

Dentron GLA1000B.....	295.00
Dentron Clipperton L.....	499.00
Bearcat 250, 220.....	299.00
300.....	399.00

MASTERCHARGE • VISA

All prices fob Houston except where indicated. Prices subject to change without notice, all items guaranteed. Some items subject prior sale. Send letterhead for Dealer price list. Texas residents add 6% tax. Please add postage estimate \$1.00 minimum.



MADISON
Electronics Supply, Inc.

1508 McKinney • Houston, Texas 77002 • (713) 858-0268

AD INDEX

AR Technical Products, Inc.	68
Aluma Tower Co.	68
Antenna Supermarket	79
Barry Electronics	35
Bencher, Inc.	70, 80
DSI Instruments	59
Digitrex Electronics	70
Ehrhorn Technological Operations	44
Hal Communications Corp.	9
Ham Gear Mart	74
Ham Radio's Bookstore	34, 46, 50, 51, 58, 62
Ham Radio Horizons	62, 80
Heath Company	Cover IV
Hustler, Inc.	35
Icom	7
KLM Electronics, Inc.	77
Kantronics	55
Trio-Kenwood Communications, Inc.	Cover III
Larsen Antennas	39
Long's Electronics	40, 41,
MFJ Enterprises	3
Madison Electronics Supply	62, 78
Microcraft Corporation	79
Microwave Filter, Inc.	80
NCG Companies	74
Oak Hill Academy Amateur Radio Session	44
Palomar Engineers	43, 46
Panasonic	29
RSE Ham Shack	28
Radio Amateur Callbook	45
Radio & Electronics Constructor	79
Radio World	70
Record	70
S-F Amateur Radio Services	79
Slep Electronics Company	79
Ten-Tec	Cover II
The Ham Key Company	67
Van Gorden Engineering	51
Wilson Systems, Inc.	1, 4, 10, 23

Foreign Subscription Agents for Ham Radio HORIZONS

Ham Radio Austria
F. Batti
Hauptplatz 5
A-2700 Wiener Neustadt
Austria

Ham Radio Holland
MRL Electronics
Postbus 68
NL-2204 Delft
Holland

Ham Radio Belgium
Stereohouse
Brusselsesteenweg 416
B-9218 Gent
Belgium

Ham Radio Italy
G. Vulpatti
P.O. Box 37
I-22063 Cantù
Italy

Ham Radio Canada
Box 400, Goderich
Ontario, Canada N7A 4C7

Ham Radio Switzerland
Karin Ueber
Postfach 2454
D-7850 Loerrach
West Germany

Ham Radio Europe
Box 444
S-194 04 Upplands Vastby
Sweden

Ham Radio UK
P.O. Box 63, Harrow
Middlesex HA3 6HS
England

Ham Radio France
SM Electronic
20 bis, Ave des Clairons
F-95000 Auxerre
France

Ham Radio Germany
Karin Ueber
Postfach 2454
D-7850 Loerrach
West Germany

Holland Radio
143 Greenway
Greenalide, Johannesburg
Republic of South Africa



... at last ...
your shack organized!
 A beautiful piece of furniture — your XYL will love it!
\$16450 S-F RADIO DESK
 Deluxe - Ready to Assemble

Designed with angled rear shelf for your viewing comfort and ease of operation.

FINISHES: Walnut or Teak Stain.
 Floor Space: 39" Wide by 30" Deep

Additional Information on Request.
 Checks, Money Orders, BankAmericard
 and Master Charge Accepted.

F.O.B. Culver City. (In Calif. Add 6% Sales Tax.)

DEALER INQUIRIES INVITED

S-f Amateur Radio Services

4384 KEystone AVENUE • CULVER CITY, CALIF. 90230 — PHONE (213) 837-4870

\$9

Radio equipment
not included

Also Available
 Floor Space: 51" Wide by 30" Deep
 \$192.50

Microcraft's New Morse-A-Word

Eight character moving display.
 Built-in code practice oscillator.
 Excellent for learning Morse Code.
 Complete — no CRT or expensive
 extras needed.

Decodes audio CW signals from your
 receiver's speaker and displays letters,
 numbers, punctuation and special Morse
 characters as the code is received.

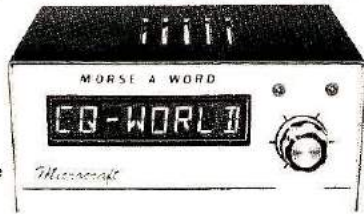

MORSE-A-WORD Kit with 4 character readout MAWK-4 \$149.95
 MORSE-A-WORD Kit with 8 character readout MAWK-8 \$169.95
 MORSE-A-WORD wired & tested with 8 character readout ... MAWF \$249.95

Send check or money order. Use your VISA or Master Charge. Add \$3.50 shipping
 and handling for continental U.S. Wisconsin residents add 4% State Sales Tax.

Microcraft

Corporation Telephone: (414) 241-8144
 P. O. Box 513HRH, Thiensville, Wisconsin 53092

**SLEP
 MAIL-ORDER
 SPECIALS**

TEN-TEC

545 OMNI-A ANALOG SERIES B TRANSCEIVER	\$845.00
546 OMNI-D DIGITAL SERIES B TRANSCEIVER	965.00
252 MD MATCHING OMNI P/S	125.00
248 NOISE BLANKER OMNI	44.00
645 ULTRAMATIC KEYSER OMNI	76.00
243 REMOTE VFO OMNI	130.00
217 FILTER 500 HZ OMNI	49.00
218 FILTER 1.8 KHZ OMNI	49.00
580 DELTA DIGITAL TRANSCEIVER	739.00
280 MATCHING DELTA P/S	125.00
282 FILTER 200 HZ DELTA	45.00
285 FILTER 500 HZ DELTA	45.00
215P MICROPHONE WITH PLUG ALL MODELS	26.00
234 SPEECH PROCESSOR ALL MODELS	119.00
214 MICROPHONE FOR 234	38.00
247 ANTENNA TUNER ALL MODELS	62.00
515 ARGONAUT SW NEW MODEL	379.00
210 ARGONAUT P/S	32.00
570 CENTURY 21 70W. CW. XCEIVER	310.00
275 CRYSTAL CALIBRATOR 570	26.00
1140 DC CIRCUIT BREAKER	8.75
1150 OVERVOLTAGE PROTECTOR 252/262	15.00

ICOM

551 TRANSCEIVER 6M 10W AC	445.00
551D TRANSCEIVER 6M 80W DC	625.00
PS-20 P/S 20 AMP 551D	185.00
EX106 FM OPTION 551, 551D	115.00
EX107 VOX OPTION 551	49.00
EX108 PB TUNE 551	98.00
701 TRANSCEIVER HF WITH 701 P/S	1,245.00
255A FM 2M 25W SYN 12V	365.00
251 FM/SSB 2M MULTIMODE 115V/12 VDC	649.00
260A FM/SSB 2M 12V	445.00
SP2 MATCHING SPEAKER 701, 551	49.50
CF-1 COOLING FAN 701PS, PS-20	39.00
EX-1 RELAY Y INTERFACE 701	35.00
HP-1 HEADPHONE ALL MODELS	29.50
HM-8 TOUCH TONE MIKE, 251A	39.50
SM-5 DESK MIKE 251A, 255A	32.50
SM-2 DESK MIKE 701, 211	32.50
RM-2 CONTROLLER 701, 211, 245	145.00

SWAN

100MX TRANSCEIVER 12V	585.00
ASTRO 150 TRANSCEIVER 12V	795.00
ASTRO 102 BX TRANSCEIVER 12V	995.00
PSU-5 P/S 100MX, ASTRO 150	158.00
PSU-6 P/S ASTRO 102BX	188.00
WM6200 VHF WATTMETER 50-150 MHZ	65.00
4010V VERTICAL ANTENNA 10-40M NO RADIALS	
REQUIRED	74.00
75AK ADD-ON 75/80M	35.00

TEMPO

S1 2M, SYN HAND-HELD W/BATTERY PACK, CHARGER AND TEL ANT	275.00
S1T SAME AS ABOVE WITH TOUCH-TONE INSTALLED	299.00
TS-CC CARRYING CASE	16.00
TS-HA HELICAL ANTENNA	8.00
TS-MC CIGARETTE LIGHTER CHARGER	6.50
S-30 SOLID STATE 30W AMPLIFIER FOR S1 SERIES	139.00
S-5 2M SYN HH TRANS 1/5W BATT PACK, CHARGER & TEL ANT	309.00
S-5T SAME AS ABOVE WITH TOUCH-TONE INSTALLED	359.00

DRAKE

TR7/DR-7 TRANSCEIVER DIGITAL	1,325.00
PS-7 POWER SUPPLY TR-7/DR-7	239.00
NB-7 NOISE BLANKER	80.00
SL-300, SL-500, SL-1800, SL-6000 FILTERS EACH	49.00
FA-7 FAN	29.00
RV-7 REMOTE VFO TR-7	173.00
MS-7 SPEAKER	37.00
7077 DESK MIKE W/PLUG TR-7	44.00
NMK-7 MOBILE MOUNT KIT TR-7	45.00
L-7 AMPLIFIER W/PS AND TUBES	1,080.00
MN-7 TUNER 250W 160-10M	159.00
MN-2700 TUNER 1KW 160-10M	269.00
CS-7 REMOTE CONTROLLED ANT SWITCH	158.00
DL-300 DRY DUMMY LOAD 300W	26.95
DL-1000 DRY DUMMY LOAD 1KW	53.00
WH-7 WATTMETER 1.8-54 MHZ	80.00
TV-3300LP LOW PASS FILTER 1KW	24.00
R-7/DR-7 DIGITAL RECEIVER 0-30 MHZ	1,165.00

ORDER BY MAIL OR PHONE BILL SLEP 704-524-7519. WE PAY SHIPPING TO 50 STATES, APO, FPO, — MASTER CHARGE, VISA, OR CHECKS ACCEPTED, SAVE MONEY BY ORDERING TODAY.

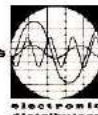

SLEP ELECTRONICS COMPANY

P.O. BOX 100, HIGHWAY 441, DEPT. HH
 OTTO, NORTH CAROLINA 28763

Hobbyists:
RADIO ELECTRONICS CONSTRUCTOR

Here is an interesting general electronics hobby magazine. It's loaded with lots of interesting ideas, not only about radio, but in all phases of electronics including test gear, audio, remote control and security systems. We are sure that you will find a number of worthwhile projects in this British magazine. For a sample copy, please send \$1 to cover postage and handling costs. Your dollar is applied to the cost of the subscription when ordered.

1 Year (12 issues) \$20.00
Radio & Electronics Constructor
 Greenville, NH 03048

EAVESDROPPER SWL ANTENNA!
 Your ear to the world of Short Wave Listening...

RADIO ANGOLA
 RADIO MOSCOW
 VOA
 RADIO FREE EUROPE
 Deutsche Welle
 Tokyo Calling
 BBC

60, 49, 41, 31, 25, 19, 16 and 13 meters. All the world's shortwave broadcast bands are yours with Antenna Supermarket's trap-tuned "Eavesdropper" all band antenna. Individually tuned traps make the Eavesdropper perform just as if it were eight separate antennas, each tuned to a different international broadcast band.

Its 100-foot long 72-ohm balanced feedline provides an exact match to the antenna on every band, assuring that the maximum signal possible gets to your receiver's antenna terminals while cancelling out noise picked up by the feedline.

The Eavesdropper comes completely assembled and ready to install with 50 feet of 450 pound test nylon rope. The Eavesdropper itself is 42" 2" long, made of tough #14 copper antenna wire to insure it'll survive those severe winter storms that bring down lesser antennas.

**BRING THE WORLD TO YOUR EARS...
 ORDER YOUR EAVESDROPPER TODAY!**

Only \$64.50, plus \$2.50 UPS (U.S.A.), from your favorite dealer or direct

Ill. residents add 6% sales tax.

ANTENNA SUPERMARKET Box 563, Palatine, IL 60067 (312) 359-7092

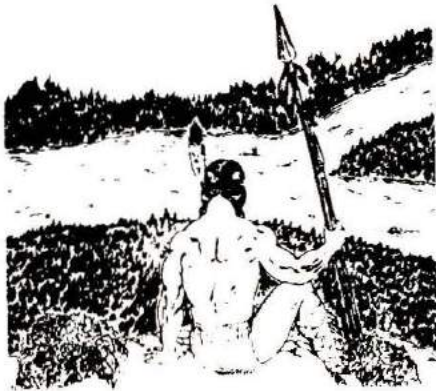

UNADILLA

FULL POWER - QUALITY

HAM ANTENNA ACCESSORIES
at your dealer

the Big Signal
W2AU
Balun



the Old reliable
W2VS Traps



HAMS - call for our
free catalog PC-80

DEALERS - join over 400
dealers world-wide. Call
us today for no-risk deal.

HAMFEST MANAGERS -
UNADILLA cooperates!
Call us.

US - TOLL-FREE 1-800-448-1666
NY & Canada - COLLECT -
1-315-437-3953

Ask for Hugh Gunnison, WA2ZOT,
or Bonnie, or Emily.

For over 20 years, the choice
of Hams, Armed Forces and
Commercial Communications - world-wide.

W2AU/W2VS - HAM ANTENNA ACCESSORIES



5-Band
Antenna
Kit

- Lo-Pass Filter 2000W
- Quad Parts
- Baluns / Traps
- Insulators
- Wire & Cable
- Connectors

UNADILLA / REYCO Division Microwave Filter Co., Inc., E. Syracuse, NY 13057

**the
Ultimate
IAMBIC
PADDLE**

WRITE FOR LITERATURE
BENCHNER, inc.
333 W. Lake Street, Dept. A
Chicago, Illinois 60606 • (312) 263-1808

- Full range of adjustment in tension and contact spacing.
- Self-adjusting nylon and steel needle bearings.
- Solid silver contact points.
- Polished lucite paddles.
- Precision-machined, chrome plated brass frames.
- Standard model has black, textured finish base; deluxe model is chrome plated.
- Heavy steel base; non-skid feet.

Available at selected dealers or send \$42.95 (\$52.95 for chrome model) plus \$2.00 shipping and handling. Overseas amateurs invited to request quotation for air parcel post shipment.

HELP!

Anytime you have a question about your Ham Radio HORIZONS subscription, please include a mailing label to insure prompt service on your inquiry.

CHANGE OF ADDRESS

Moving? Please let us know 4-6 weeks beforehand. Or, if anything is wrong with your current mailing label, please carefully print the updated information below and affix your present label above.

PLEASE HELP US TO SERVE YOU BETTER

HAM RADIO HORIZONS Greenville, NH 03048

Call _____

Name _____

Address _____

City _____

State _____ Zip _____

AFFIX
LABEL
HERE

"Cents-ability" in an HF rig.



A quality 160-10 meter SSB/CW transceiver

TS-520SE

The TS-520SE is the economical, full-featured, most popular 160-10 meter Amateur transceiver in the world. Now anyone can easily afford to put a high-quality HF transceiver in his ham-shack... a rig which provides 200 watts PEP input on SSB and 160 watts DC on CW!

TS-520SE FEATURES:

- **Covers 160-10 meters... and WWV**
Provides full coverage of all Amateur bands from 1.8 to 29.7 MHz, plus WWV on 15 MHz
- **Digital display (optional)**
The optional DG-5 provides easy, accurate readout of the actual operating frequency while transmitting and receiving
- **CW WIDE/NARROW bandwidth switch**
For use with optional CW-520 500-Hz filter
- **Speech processor**
Provides extra audio punch on transmit, while suppressing sideband splatter

- **Highly effective noise blanker**
Virtually eliminates pulse-type noise
- **Solid-state, with tube driver and final**
Vernier control allows easy and accurate adjustment of final plate tuning
- **High sensitivity and dynamic range**
Dual-gate MOSFET provides outstanding cross-modulation and spurious response characteristics, with low noise figure and high gain for excellent sensitivity
- **Amplified-type AGC circuit**
Three-position AGC switch (OFF/FAST/SLOW) provides optimum receiver operation on CW and SSB, under all signal-strength conditions
- **RF attenuator**
Built-in 20-dB attenuator activated by front-panel push-button switch
- **RIT control**
Receiver incremental tuning, or "clarifier"
- **Eight-pole crystal filter**
For excellent selectivity
- **Built-in 25-kHz calibrator**
To maintain frequency accuracy. Adjustable to WWV

- **Amplified-type ALC**
Improves quality of transmitted signal
- **Front-panel carrier level control**
To adjust CW output power
- **Semi-break-in CW with sidetone**
Keying delay adjustable with VOX delay control
- **VOX/PTT/MANUAL operation**
Suits all operating requirements
- **TUNE position for low-power tune-up**
Provides longer final tube life
- **Built-in speaker**
Excellent audio quality
- **Built-in cooling fan**
Extends life of components
- **Provisions for four fixed channels**
Ideal for net or MARS operation
- **Rugged die-cast front panel**
Very attractive design

Ask your Authorized Kenwood Dealer about the TS-520SE...and its surprisingly affordable price!

NOTE: Price, specifications subject to change without notice and obligation.

MATCHING ACCESSORIES FOR FIXED-STATION OPERATION:

- SP-520 external speaker
- DG-5 digital frequency display/counter
- VFO-520S remote VFO
- **Other accessories not shown:**
- CW-520 500-Hz CW filter
- AT-200 antenna tuner/SWR and RF power meter/antenna switch
- TL-922A linear amplifier
- SM-220 Station Monitor with BS-5 pan display module option
- MC-50 dynamic desk microphone
- MC-35S noise-cancelling, high-impedance microphone
- HS-5 and HS-4 headphones
- PC-1 phone patch
- HC-10 world digital clock



Two smart, new, money-saving ideas for Hams from...who else but the Hams at Heath

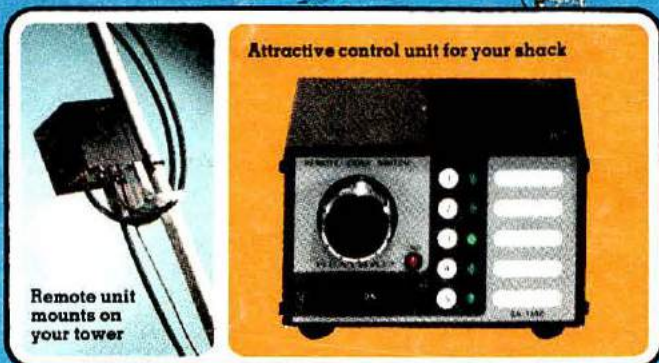
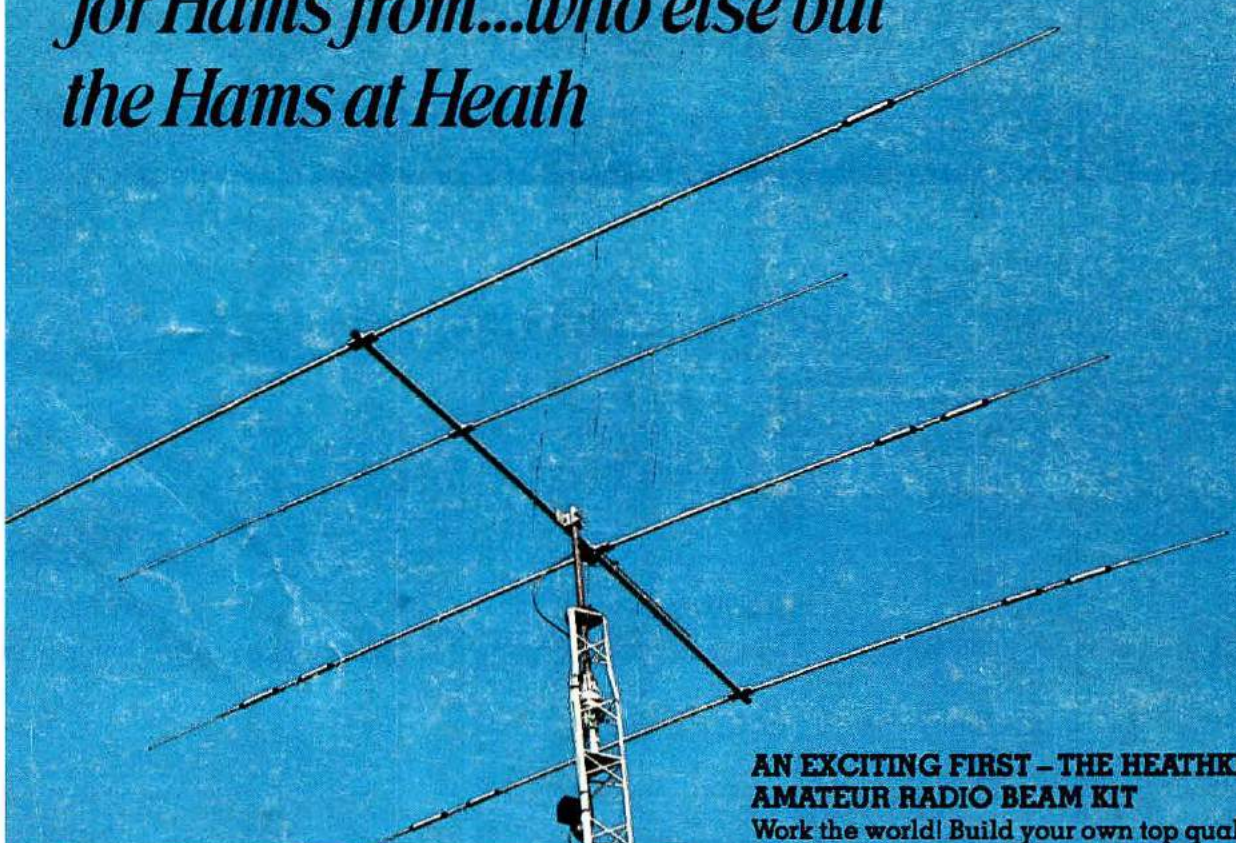

Remote unit
mounts on
your tower

Attractive control unit for your shack

Complete details on the new SA-7010 Tri-Band Beam and the SA-1480 Remote Coax Switch... and nearly 400 other kits you build yourself are in the colorful new Heathkit Catalog.

FREE HEATHKIT CATALOG

Send today for your free, 104-page Heathkit Catalog. Or pick one up at your nearby Heathkit Electronics Center* where Heathkit Products are displayed, sold and serviced. See your white pages for the location nearest you.

*Units of Veritechnology Electronics Corporation.

Send to Heath Company, Dept. 348-654
Benton Harbor, MI 49022



AN EXCITING FIRST - THE HEATHKIT AMATEUR RADIO BEAM KIT

Work the world! Build your own top quality Tri-Band Beam with famous Heathkit instructions to guide you. And what a beam! Three active elements give 1.5:1 or less SWR on each band for efficient energy transfer. This full power beam is great for your home QTH. Easy assembly makes it perfect for your club's Field Day activities, too. Read all about it, including gain figures, in the latest Heathkit Catalog.

THE NEW HEATHKIT REMOTE COAX SWITCH KEEPS YOU DRY

Hate rain and snow? Change antennas by turning the knob on your SA-1480 Remote Coax Switch. It replaces five expensive coax feed-lines with just one. Lightning-protect position, too. Rated full legal power to 150 mHz.

HEATHKIT[®] AMATEUR RADIO

*There's more for the Ham
at Heath*