

# **ham** **radio** *magazine*

- fixed-tuned LF converter
- an interview with Dr. Kenneth Davies of NOAA
- a simplex autopatch
- the logic mate

## **FIRST REPORT: PROPAGATION ON THE NEW BANDS**

**hr**   
focus  
on  
communications  
technology



**10.100**  
**18.068**  
**24.89**

# IC-740

## Extensive Versatility for the Serious Operator



**The IC-740 from ICOM** contains all of the most asked for features, in the most advanced solidstate HF base station on the amateur market...performing to the delight of the most discerning operator.

Study the front panel controls of the ICOM IC-740. You will see that it has all of the functions to give maximum versatility to tailor the receiver and transmitter performance to each individual operator's requirements.

Features of the IC-740 receiver include variable width and continuously adjustable noise blanker, continuous, adjustable speed AGC, adjustable IF shift and variable passband tuning built in. In addition, an adjustable notch filter for maximum receiver performance, along with switchable

receiver preamp, and a selection of SSB and CW filters. Squelch on SSB Receive and all mode capability, including optional FM mode. Split frequency operation with two built-in VFOs for the serious DX'er.

The IC-740 allows maximum transmit flexibility with front panel adjustment of VOX gain and VOX delay along with ICOM's unique synthesized three speed tuning system and rock solid stability with electronic frequency lock. Maximum versatility with 2 VFO's built in as standard, plus 9 memories of frequency selection, one per band, including the new WARC bands.

With 10 independent receiver and 6 transmitter front panel adjustments, the IC-740 operator has full control of his station's operating requirements.

See and operate the versatile and full featured IC-740 at your authorized ICOM dealer.

### Options include:

- FM Module
- Marker Module
- Electronic Keyer
- 2 - 9MHz IF Filters for CW
- 3 - 455KHz Filters for CW
- Internal AC Power Supply

### Accessories.

- SM5 Desk Microphone
- UP/DWN Microphone
- Linear Amplifier
- Autbandswitching Mobile Antenna
- Headphones
- External Speaker
- Memory Backup Supply
- Automatic Antenna Tuner

 **ICOM**  
The World System

# Now! A 60 MHz Tektronix scope built for your bench.

**Wide-range vertical sensitivity:**  
Scale factors from 100 V/div (10X probe) to 2 mV/div (1X probe). Accurate to  $\pm 3\%$ . Ac or dc coupling.

**Two high-sensitivity channels:** dc to 60 MHz bandwidth from 10 V/div to 20 mV/div; extended sensitivity of 2 mV/div at  $> 50$  MHz.

**Sweep speeds:**  
from 0.5 s to 50 ns. To 5 ns/div with X10 magnification.

**Delayed sweep measurements:**  
Accurate to  $\pm 3\%$  with single time-base 2213; to  $\pm 1.5\%$  with dual time-base 2215.

**Complete trigger system.** Includes TV field, normal, vertical mode, and automatic; internal, external and line sources; variable holdoff.

**Probes included.** High-performance, positive attachment 10-14 pF and 60 MHz at the probe tip.



**In 30 years of Tektronix oscilloscope leadership, no other scopes have recorded the immediate popular appeal of the Tek 2200 Series.** The Tek 2213 and 2215 are unapproachable for the performance and reliability they offer at a surprisingly affordable price.

There's no compromise with Tektronix quality: The low cost is the result of a new design concept that cut mechanical parts by 65%. Cut cabling by 90%. Virtually eliminated board electrical connectors. And eliminated the need for a cooling fan.

Yet performance is written all over the front panels. There's the bandwidth for digital and analog circuits. The sensitivity for low signal measurements. The sweep speeds for fast logic families. And delayed sweep for fast, accurate timing measurements.

**The cost: \$1200\* for the 2213. \$1450\* for the dual time base 2215.** You can order, or obtain more information, through the Tektronix National Marketing Center, where technical personnel can answer your questions and expedite delivery. Your direct order includes

probes, operating manuals, 15-day return policy and full Tektronix warranty.

For quantity purchases, please contact your local Tektronix sales representative.

**Order toll free:  
1-800-426-2200  
Extension 55**

In Oregon call collect:  
(503) 627-9000 Ext. 55

\*Price F.O.B. Beaverton, OR. Price subject to change.



## TS-830S

**"Top-notch"...VBT, notch, IF shift, wide dynamic range**

The TS-830S has every conceivable operating feature built-in for 160-10 meters (including the three new bands). It combines a high dynamic range with variable bandwidth tuning (VBT), IF shift, and an IF notch filter, as well as very sharp filters in the 455-kHz second IF.

### TS-830S FEATURES:

- LSB, USB, and CW on 160-10 meters, including the new 10, 18, and 24-MHz bands. Receives WWV on 10 MHz.

- Wide receiver dynamic range. Junction FETs in the balanced mixer, MOSFET RF amplifier at low level, and dual resonator for each band.
- Variable bandwidth tuning (VBT). Varies IF filter passband width.
- Notch filter high-Q active circuit in 455-kHz second IF.
- IF shift (passband tuning).
- Noise-blanker threshold level control.
- Built-in digital display. (fluorescent tube), with analog dial.
- 6I46B final with RF negative feedback. Runs 220 W PEP (SSB)/180 W DC (CW) input on all bands.
- Built-in RF speech processor.
- Narrow/wide filter selection on CW.
- SSB monitor circuit.
- RIT and XIT (transmitter incremental tuning).

### Optional accessories:

- SP-230 external speaker.
- VFO-230 external digital VFO with five memories, digital display.
- VFO-240 external analog VFO.
- AT-230 antenna tuner.
- YG-455C (500 Hz) or YG-455CN (250 Hz) CW filter for 455 kHz IF.
- YK-88C (500 Hz) or YK-88CN (270 Hz) CW filter for 8.83 MHz IF.
- KB-1 deluxe heavyweight knob.



## TS-530S

**"Cents-ational"...IF shift, digital display, narrow-wide filter switch**

The TS-530S SSB/CW transceiver covers 160-10 meters using the latest, most advanced circuit technology, yet at an affordable price.

### TS-530S FEATURES:

- 160-10 meters, LSB, USB, CW, all amateur frequencies, including new 10, 18, and 24 MHz bands. Receives WWV on 10 MHz.
- IF shift tunes out interfering signals.

- Built-in digital display (six digits, fluorescent tubes), with analog dial.
- Narrow/wide filter selector switch for CW and/or SSB.
- Built-in speech processor, for increased talk power.
- Wide receiver dynamic range, with greater immunity to overload.
- Two 6I46B's in final, allows 220W PEP/180 W DC input on all bands.
- Advanced single-conversion PLL, for better stability, improved spurious characteristics.
- Adjustable noise-blanker, with front panel threshold control.
- RIT/XIT front panel control allows independent fine-tuning of receive or transmit frequencies.

### Optional accessories:

- SP-230 external speaker with selectable audio filters.
- VFO-240 remote analog VFO.
- VFO-230 remote digital VFO.
- AT-230 antenna tuner/SWR/power meter.
- MC-50 desk microphone
- KB-1 deluxe VFO knob.
- YK-88C (500 Hz) or YK-88CN (270 Hz) CW filter.
- YK-88SN (1.8 kHz) narrow SSB filter.



## TS-660

**The TS-660 "QUAD BANDER" covers 6, 10, 12, 15 meters.**

- FM, SSB (USB), CW, and AM
- Dual digital VFO's
- Digital display
- IF shift built-in
- 5 memories with memory scan
- UP/DOWN microphone
- All-mode squelch
- Noise blanker
- CW semi break-in/sidetone
- 10 W on SSB, CW, FM; 4 W on AM.

### Optional accessories:

- PS-20 power supply
- VOX-4 speech processor/VOX
- SP-120 External speaker
- MB-100 Mobile mount
- YK-88C, YK-88CN CW filters
- YK-88A AM filter.

# KENWOOD

**TRIO-KENWOOD COMMUNICATIONS**

1111 West Walnut, Compton, California 90220

# SAVE \$10.50\* with home delivery

Payment enclosed

Bill me later

U. S. prices only

\*One year newsstand cost \$30.00)

Here's my address label, enter my subscription.

1 Year . . . . . 12 issues . . . . . \$19.50

2 Years . . . . . 24 issues . . . . . \$32.50

3 Years . . . . . 36 issues . . . . . \$42.50

Name

Zip

State

Address

City

Check here if this is your renewal (attach label)

# Subscribe to **ham** **radio** magazine

Please allow 4-6 weeks for delivery issues.

**Foreign rates:** Europe, Japan and Africa for one year by air forwarding service countries \$21.50 for one year by surfe

Please  
enter my  
subscription



**BUSINESS REPLY CARD**  
First Class    Permit No. 1    Greenville NH

Postage Will Be Paid By Addressee

**ham  
radio**

Greenville, NH 03048

NO POSTAGE  
NECESSARY  
IF MAILED  
IN THE  
UNITED STATES

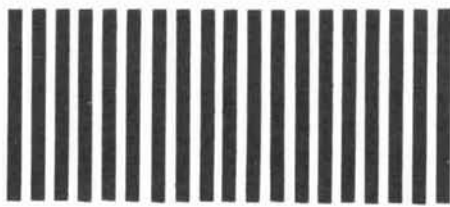

# ham radio

magazine

JANUARY 1983

volume 16, number 1

**T. H. Tenney, Jr., W1NLB**  
publisher and  
editor-in-chief

**Martin Hanft, KA1ZM**  
editor

**Rich Rosen, K2RR**  
senior technical editor  
and associate publisher

**editorial staff**

Debra Marshall  
managing editor

Alfred Wilson, W6NIF  
Joseph J. Schroeder, W9JUV  
Leonard H. Anderson  
associate editors

Susan Shorrock  
production

**publishing staff**

J. Craig Clark, Jr., N1ACH  
assistant publisher

Rally Dennis  
director of advertising sales

Susan Shorrock  
circulation manager

Therese Bourgault  
circulation

ham radio magazine  
is published monthly by  
Communications Technology, Inc  
Greenville, New Hampshire 03048-0498  
Telephone: 603-878-1441

**subscription rates**

United States: one year, \$19.50  
two years, \$32.50; three years, \$42.50  
Canada and other countries (via Surface Mail)  
one year, \$21.50; two years, \$40.00  
three years, \$57.00

Europe, Japan, Africa (via Air  
Forwarding Service) one year, \$28.00

All subscription orders payable in  
United States funds, please

**foreign subscription agents**

Foreign subscription agents are  
listed on page 79

Microfilm copies  
are available from  
University Microfilms, International  
Ann Arbor, Michigan 48106  
Order publication number 3076

Cassette tapes of selected articles  
from ham radio are available to the  
blind and physically handicapped  
from Recorded Periodicals  
919 Walnut Street, 8th Floor  
Philadelphia, Pennsylvania 19107

Copyright 1982 by  
Communications Technology, Inc  
Title registered at U.S. Patent Office

Second class postage  
paid at Greenville, N.H. 03048-0498  
and at additional mailing offices  
ISSN 0148-5989

Postmaster send Form 3579 to ham radio  
Greenville, New Hampshire 03048-0498



## contents

**12 new band propagation**

R.P. Haviland, KK2XJM (W4MB)

**19 a fixed-tuned LF converter**

S.J. DeFrancesco, K1RGO

**25 graphic azimuth and  
elevation calculator**

Noel J. Petit, WBØVGI

**28 an interview with  
Dr. Kenneth Davies**

Rich Rosen, K2RR

**36 remote-site receivers  
and repeater operation**

Bob Heil, K9EID

**42 the simplex autopatch**

Robert K. Morrow, Jr., WB6GTM

**57 logic mate**

Paul Selwa, N9CZK

**62 forget memory**

Joe Moell, KØOV

**66 ham radio techniques**

Bill Orr, W6SAI

**92 advertisers index**

**8 comments**

**74 DX forecaster**

**79 flea market**

**88 ham mart**

**70 ham notes**

**82 new products**

**10 presstop**

**92 reader service**

**6 reflections**

**22 technical forum**

**An Amateur must have the permission** of a TV broadcaster before he can buy equipment to get on a certain Amateur band? That's the decision of a California Superior Court judge in Sacramento County! Of course the issues involved are not nearly so simple as stated above. But whatever the background and however compelling the arguments favoring such a decision, the fact that any commercial enterprise has been given control of the activities of an FCC-licensed Amateur has to be of grave concern to all Amateurs. Here's what happened:

A Multipoint Distribution Service (MDS) in Sacramento, California — California Satellite Systems — went to court for a preliminary injunction against a Sacramento Amateur-equipment distributor and several others for "unfair competition," alleging they were selling equipment for receiving the MDS company's 2150-MHz subscription TV signals, and thus unjustly depriving it of revenue. The judge concurred, despite testimony about the nearby 2300-MHz Amateur band and an in-court demonstration of 2300-MHz Amateur equipment. In granting the injunction, which strictly forbids any of the defendants from selling *any* equipment *capable* of being used to receive 2150-MHz MDS TV, the judge included a proviso that such equipment could be sold to a licensed Amateur or "experimenter in microwave frequency transmissions." The section of the injunction order of serious concern to Amateurs is the requirement that prior approval (at no charge) must be obtained from the MDS company before such a sale can be made.

The case, of course, brings up many questions about individual and business rights. The problems of scrambled UHF TV "pirating," and the private reception of both MDS and satellite TV, are currently receiving plenty of attention from both the trade press and — as in this case — the courts. "Rights" mean different things to different people. There's one school of thought that holds that "anyone who doesn't want me to enjoy his radio/TV transmission should keep them off my property." This viewpoint has considerable popular support. A drive-in theater operator who sued to prevent neighboring home-owners from enjoying his movies from their back yards would be laughed out of court. Yet in St. Paul, Minnesota, a federal district judge ordered a home-owner to take down his MDS receiver or start paying the company a subscription fee!

One remedy for "pirate" subscription-TV reception that has been widely employed is legal sanctions against the manufacture and sale of equipment. In California this led the state legislature to pass a law prohibiting not only the sale of decoders but also of any components that could be used in their manufacture! Court injunctions against decoder sale and manufacture, and even the distribution of decoder kits, have been granted in a number of actions across the country; but in this case the judge has taken the process one onerous step further.

In this case, the application of such legal principles as "prior restraint" and "presumption of guilt" must be questioned. The possessor of a Technician or higher class Amateur license has been granted the right to operate on all VHF and higher frequencies by the FCC. However, in Sacramento this right, at least with respect to the 2300 MHz band, can be subject to the whim of a commercial enterprise — a commercial enterprise that has no interest whatsoever in the furtherance of Amateur Radio but has a very real interest in keeping any and all "amateurs" (note the small "a") and other experimentally inclined individuals away from "their" portion of the spectrum. To their credit, California Satellite Systems' lawyer has contacted Westlink asking the Amateur community for suggestions as to how both their interests and ours can best be protected. Any suggestions can be sent to us here in Greenville, and we'll see they get to the law firm.

However good the intentions of the MDS firm in this case, this decision is one that cannot be allowed to go unchallenged. If it stands, then why not give a channel 2 TV station the right to determine what kind of 6-meter gear is sold in its viewing area, and to whom? After all, 6-meter Amateur interference could drive viewers to other channels, thus depriving the station of revenue. Or why not let a cable system operator establish quiet hours for his area's 2-meter operators, since cable channel E (145 MHz) is used for extra-charge special events on many systems?

The Personal Communications Foundation, the ARRL, and many concerned individual Amateurs are closely following the developments in Sacramento. We must not let such a fundamental intrusion on the rights of licensed Amateurs remain unchallenged.

**Joe Schroeder, W9JUV**  
associate editor



# Picture where you can go with a \$99.<sup>95</sup> computer.

Remember when they said all computers would be affordable someday?

Well, here they are. All one of them.

## The only \$99.95 computer.

Now you don't have to spend hundreds or even thousands of dollars to enjoy some really useful and interesting software programs.

You can own a full powered TS1000 personal computer for only \$99.95. And you can buy it directly from Sinclair Research, the company that pioneered the affordable computer. Only Sinclair has made this revolutionary new technology possible, with a unique Master Chip which replaces as many as 18 chips used in other personal computers.

The TS1000 is the lowest priced personal computer on the market. In addition to being very affordable, it's very expandable.

You can select from a number of 1K software programs for the basic computer. You can also learn how to write your own programs.

## The 16K Memory Module. More power to you.

For only \$49.95 more, you can purchase our 16K Memory Module and use even more sophisticated software. Choose from a wider selection of games, educational programs and business/household applications.

The 16K Memory Module plugs right onto the back of the Timex/Sinclair 1000 and provides 8 times more memory capacity. The perfect way to expand your system without emptying your wallet.

## A computer even the merely curious can afford.

The TS1000 is designed precisely for you. Anyone can afford it. Anyone can learn how to use it.

So now even the curious can take advantage of our many software cassettes, which work with a standard cassette recorder.

The TS1000 comes with a complete software catalog and a comprehensive instruction book written in clear, simple English. And the computer hooks up to your TV for video display.

No wonder the TS1000 is the fastest selling personal computer ever. And Sinclair will let you try it in your home for 10 days at no risk.

## Buy three cassettes, get one free. A good reason to order now.

The fact that computers are here to stay is probably reason enough to order now.

However, we also feature a special software offering. When you buy three cassettes, you get a free cassette. It's as simple as that. And now you can buy the computer and both 1K programs and 16K programs right from your home. No crowds, no waiting lines, no parking worries. Selecting from such a large variety of software has never been easier or more convenient.

But you have to order right away, this is a limited time offer.

## How to order today.

Call our toll free number and use your MasterCard or VISA. Or send the coupon with a check or money order.

Then try out the Timex/Sinclair 1000 for

The Flight Simulator

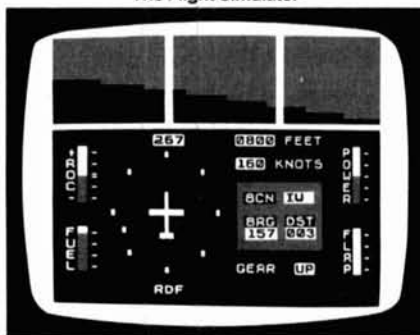

Space Raiders

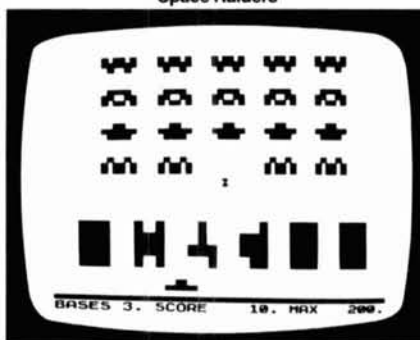

Backgammon

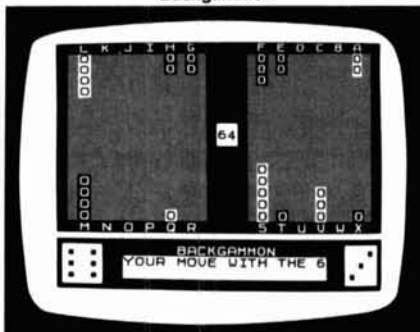

VU-CALC



**sinclair**

10 days. If you're not entirely satisfied, just return it to us and we will refund your money. (Sorry, no refunds on software.)

Call toll free: 800-543-3000. Ask for operator 509. In Ohio call: 800-582-1364. Ask for operator 509. In Canada call 513-729-4300, operator 509. Have your MasterCard or VISA ready when calling. Phones open 24 hours a day, 7 days a week. These numbers are for orders only.

If you want information, please write: Sinclair Research Ltd., 2 Sinclair Plaza, Nashua, NH 03061.

Call toll free

# 800-543-3000

Ad code: BIHR01 Mail to: Sinclair Research, Ltd.  
One Sinclair Plaza, Nashua, NH 03061

Check or Money Order enclosed

	Price	Qty.	Amount*
TS1000 Computer	\$99.95		
16K RAM	\$49.95		

Check the boxes of all software cassettes you want. If you select any three cassettes, get one free. You must circle the one cassette you wish to receive free.

1K Cassettes for basic computer: \$9.00

- |   |   |
|---|---|
| <input type="checkbox"/> 1) Statistics      | <input type="checkbox"/> 3) Super Program 7 |
| <input type="checkbox"/> 2) Super Program 1 | <input type="checkbox"/> 4) Super Program 2 |
- Includes Statistics, Regression and Trend, CHI Squared Text and Graphics Plot
- Invasion from Jupiter, Skittles, Magic Square, Doodle, Kim, Liquid Capacity
- Racetrack, Chase, Nim, Tower of Hanoi, Docking the Spaceship, Golf Rings Around Saturn, Secret Code, Mind Boggling, Silhouette, Memory Test, Metric Conversion

1K Cassettes	\$9.00 each		
--------------	-------------	--	--

Cassettes for 16K Module: \$15.00

- |  |  |
|--|--|
| <input type="checkbox"/> 5) Space Raiders, Bomber                | to catalog, maintain records, keep track of accounts                         |
| <input type="checkbox"/> 6) The Flight Simulator                 | <input type="checkbox"/> 11) VU-CALC   |
| <input type="checkbox"/> 7) Chess                                | Financial analysis, budget and projection tables; a powerful analytical tool |
| <input type="checkbox"/> 8) Backgammon and Dice                  | <input type="checkbox"/> 12) The Coupon Manager                              |
| <input type="checkbox"/> 9) The Cube Game                        | List coupons by store or type  |
| <input type="checkbox"/> 10) The Organizer                       | <input type="checkbox"/> 13) The Stock Option Analyzer                       |
| General purpose information storage and retrieve program. Use it | Calculate last trading day; evaluate ROI, annual ROI and NET worth           |
|  | <input type="checkbox"/> 14) Super Math                                      |
|  | Five levels of difficulty  |

16K Cassettes	\$15.00 each		
Shipping/Handling	\$ 4.95		\$4.95

\*U.S. Dollars Total:

Name \_\_\_\_\_

Street \_\_\_\_\_

City \_\_\_\_\_

State \_\_\_\_\_ Zip \_\_\_\_\_



## comments

### no-code license

*In the September, 1982, issue of ham radio, the publisher and editor-in-chief of ham radio, Skip Tenney, W1NLB, and associate editor Joe Schroeder, W9JUV, presented an editorial in which they advocated that Amateurs look into the merits of the FCC's proposed no-code Amateur license. As expected, the response was swift and emotional. By far the majority of those who responded to the editorial were opposed to any kind of code-free license.*

*Presented below are excerpts from some of the letters received.*

The decision and dilemma of a no-code license is a two part question: fact and emotion. Let's examine some thought-provoking aspects of this question.

What is the value or purpose of Morse code? There is only one! In a marginal reception situation, the ear/thought process can interpret an on/off tone more effectively than the complex communication of the human voice. For this very reason, all military communication specialists are required to learn code. Said simply, anyone using code can get a message through where voice is unintelligible. It is also fact that on/off rf generation equipment (both sending and receiving) is simpler to develop,

understand, and build than voice generation techniques.

The second part of the no-code license proposal appears to be the emotional half. I am a ham! Not everyone can be one, because they don't have the determination, intelligence, skill, and guts to work to be a member of our fraternity. I'm pleased to be a member of a group of people who are elite and have done something to make them stand out in a crowd. Our country was founded and has grown on the principle that the best succeed and thank God we can all work to achieve what we want.

Are these questions important? What is the purpose of Amateur Radio? If you are part of a group whose lives depend on "getting the message through" (military or public service), or if you believe in the principle of our ability to "be what we want to be" (freedom), then the answer is yes.

As a final note please observe that I have underlined work many times. True appreciation of anything in life — be it mental, spiritual, or physical — is rewarded directly to the amount of effort expended by the recipient. Anything given to us quickly loses its real value without exception. Time and again we are reminded that each of us only truly enjoys what we have earned. — William E. Martin, WB4KSP.

The code requirement is the only thing keeping more lids from Bashing their way into Amateur Radio. The code represents discipline. Even if a person never uses the code once he gets his license, he has demonstrated the fact that he has the discipline necessary to be a qualified ham. Once a person learns the code he does not easily forget it. It is a skill to be proud of having.

I doubt if any ham really believes the code is outmoded, as some computer-oriented proponents would have us believe. I doubt if any ham really believes the code is an impossible stumbling block for youngsters.

There are only two reasons why a person cannot learn the code: 1) lack of interest (he really doesn't want to be a ham); or 2) laziness (he would rather be given something than earn it).

Sorry, gentlemen, you're wrong on this one. If we wind up with a no-code license, it will be due to publishers, manufacturers, and dealers . . . not because of their interest in Amateur Radio, but rather due to their pursuit of the almighty dollar. — Ken Piletic, W9ZMR.

It is perfectly ridiculous to require that computer-oriented young people, and busy young engineers with endless demands on their time, learn the code which they may never use. We urgently need these bright energetic young people in the Amateur service, and we are not attracting enough of them.

Most Amateurs oppose the no-code license because they do not want Amateur Radio to sink into a CB-type chaos. But well-conceived examinations, honestly administered, should safeguard against that. Others oppose a no-code license on the grounds that anyone can learn the code; these well-meaning people simply do not understand the problem.

It is unfortunate that the ARRL, because of the shortsighted view of most of its members, can be counted

continued on page 54

# Hear Police / Fire Weather

on 2 Meter Handhelds with  
this MFJ VHF Converter.



Scanning  
Handhelds  
become  
Police/Fire  
Scanners

MFJ-313

**\$39<sup>95</sup>**

New MFJ VHF converter turns your synthesized scanning 2 meter handheld into a hot Police/Fire/Weather band scanner.

144-148 MHz handhelds receive Police/Fire on 154-158 MHz with direct frequency readout. Hear NOAA weather, maritime coastal plus more on 160-164 MHz.

Mounts between handheld and rubber ducky. Feedthru allows simultaneous scanning of both 2 meters and Police/Fire bands. No missed calls.

Highpass input filter and 2.5 GHz transistor gives excellent uniform sensitivity over both bands. Crystal controlled.

Bypass/OFF switch allows transmitting. Won't burn out if you transmit (up to 5 watts) with converter on. Low insertion SWR. Uses AAA battery. 2 1/4 x 1 1/2 x 1 1/2 in. BNC connectors.

Enjoy scanning, memory, digital readout, etc. as provided by your handheld on Police/Fire band.

## 220 MHz Converter for 2 M Handheld

MFJ-314 MFJ-314, like MFJ-313 but lets you receive 221-225 MHz on your 2 meter handheld.

**\$59<sup>95</sup>**

## Police/Fire/Weather Band Converter for 2 Meter Mobile Rigs.



MFJ-312

**\$59<sup>95</sup>**

MFJ-312, like MFJ-313 but for mobile 2 meter rigs. Transmit up to 40 watts thru converter without damage. SO-239 connectors. Mobile mounting brackets. Rugged. "ON" LED. Use 12 VDC or AAA battery. 3x4x1 in.

Order from MFJ and try it-no obligation. If not delighted, return it within 30 days for refund (less shipping). One year unconditional guarantee.

Order today. Call toll free 800-647-1800. Charge VISA, MC or mail check, money order for amount indicated plus \$4.00 each shipping.

Hear police/fire/weather. Order now.

**CALL TOLL FREE ... 800-647-1800**

Call 601-323-5869 in Miss., outside continental USA, tech/order/repair info. Telex 53-4590.

**MFJ ENTERPRISES, INCORPORATED**

Box 494, Mississippi State, MS 39762

# MFJ DUMMY LOADS

Tune up fast into 50 ohm resistive load. Extend life of finals.



Includes  
high quality  
transformer  
oil.

**\$34<sup>95</sup>**

New MFJ-250 VERSALOAD Kilowatt Dummy Load lets you tune up fast. Extends life of transmitter finals. Reduces on-the-air QRM.

Run 1 KW CW or 2 KW PEP for 10 minutes, 1/2 KW CW or 1 KW PEP for 20 minutes. Continuous duty with 200 watts CW or 400 watts PEP. Complete with derating curve.

Quality 50 ohm non-inductive resistor. Oil cooled. Includes high quality, industrial grade transformer oil (contains no PCB).

Low VSWR to 400 MHz: Under 1.2:1, 0-30 MHz. 1.5:1, 30-300 MHz. 2:1, 300-400 MHz. Ideal for testing HF and VHF transmitters.

SO-239 coax connector. Vented for safety. Removable vent cap. Has carrying handle. 7-1/2 in. high, 6-5/8 in. diameter.

## MFJ "Dry" 300 W and 1 KW Dummy Loads.

**\$64<sup>95</sup>**



**\$26<sup>95</sup>**

MFJ-262

MFJ-260

Air cooled, non-inductive 50 ohm resistor in perforated metal housing with SO-239 connectors. Full load for 30 seconds, derating curves to 5 minutes. MFJ-260 (300 W). SWR: 1.1:1 to 30 MHz, 1.5:1 for 30-160 MHz. 2 1/2 x 2 1/2 x 7 in. MFJ-262 (1 KW). SWR: 1.5:1 for 30 MHz. 3x3x13 inches.

## MFJ HF SWR/Wattmeter

**\$29<sup>95</sup>**



MFJ-816

New MFJ-816 low cost HF SWR/Wattmeter for 1.8 to 30 MHz range. Toroidal current pickup gives uniform sensitivity over entire HF frequency. Read SWR, forward and reflected power in 2 ranges (30 and 300 watts) on two color scale. SO-239 coax connectors. 4-1/2 x 2-3/8 x 2-7/8 in.

Order from MFJ and try it. If not delighted, return it within 30 days for refund (less shipping).

One year unconditional guarantee.

Order today. Call TOLL FREE 800-647-1800.

Charge VISA, MC. Or mail check, money order. Write for free catalog.

**CALL TOLL FREE ... 800-647-1800**

601-323-5869 in MS, outside continental USA.

**MFJ ENTERPRISES, INCORPORATED**

Box 494, Mississippi State, MS 39762

# MFJ 24 HOUR CLOCKS

Your choice: dual 24 hour LCD display, or 24/12 hour with ID timer, or 12 inch quartz analog.



**\$39<sup>95</sup>** DUAL 24 HOUR LCD  
MFJ-104

Two independent 24 hour LCD displays! Read both GMT and local times at a glance.

Six digit main display has seconds readout. Four digit auxiliary. Switch reverses main/aux.

Alarm plays 4 selectable melodies. Alarm "ON" indicator. Snooze button.

Quartz timing. Synchronizable to WWV. Flip-top cover serves as stand.

Night light. Forward/reverse, fast/slow set buttons. Lock function prevents mis-setting. Display main time only, main/auxiliary or main/alarm time. Includes battery. 4x2x1/2 inches.



24/12 HOUR, ID TIMER **\$32<sup>95</sup>**  
MFJ-102

Switchable 24 hour GMT or 12 hour format. ID timer sounds every 9 minutes after reset.

Switchable seconds readout. Observed timer. Just start clock from zero and note time of event up to 24 hours.

Bright blue 0.6" vacuum fluorescent digits. Alarm with snooze function. Synchronizable with WWV. Fast/slow set buttons. Lock function prevents mis-setting. Power out, alarm "ON" indicators. 110 VAC, 60 Hz (50 Hz with simple modification). UL approved.

Black, brushed aluminum top/front. 6x2x3".

24 HOUR QUARTZ  
MFJ-105  
**\$49<sup>95</sup>**

True 24 hour quartz wall clock has huge 12 inch diameter face. Gives excellent visibility across computer /radio room.

Fifteen seconds per month accuracy. Single "AA" battery provides over one year operation, immunity from power line failure and eliminates power cord.

Sweep second hand. Brown hi-impact case. Glass front. 24 hour military time format.

Order from MFJ and try it. If not delighted, return within 30 days for refund (less shipping).

One year unconditional guarantee.

Order yours today. Call toll free 800-647-1800. Charge VISA, MC. Or mail check, money order. Add \$4.00 each for shipping and handling.

**CALL TOLL FREE 800-647-1800**

Call 601-323-5869 in Miss., outside continental USA, tech/repair info. Telex 53-4590 MFJ STKV

**MFJ ENTERPRISES, INCORPORATED**

Box 494, Mississippi State, MS 39762

AMATEUR INTRUSIONS INTO THE OFF-LIMITS 10.109-10.115 MHz portion of the new 30-meter band have resulted in complaints from the governmental agencies affected and concern in the FCC. With Amateurs from other nations using the slots forbidden to U.S. Amateurs, it's easy to slip into violation. When such an intrusion is heard, please warn the violator with a quick long-distance call to help preserve our good relations with the agencies that have legitimate access to those frequencies.

Activity On The New Band Has Been Steady but not heavy, with most users reporting it is more like 40 than 20. DX has been reasonably available, with several U.S. stations reporting more than 40 countries worked and several more near WAS by the end of November.

BURBANK (ILLINOIS) OFFICIALS HAVE FINALLY RESPONDED to their residents' suit challenging the community's anti-tower and RFI ordinance. The city, in a motion to dismiss the complaint, challenged the federal court's jurisdiction and claimed the city has a right to control "nuisances" such as RFI and antennas. A status hearing is set for December 13.

BEACON FREQUENCIES AUTHORIZED BY THE FCC FOR "AUTOMATIC" (unattended) control in its early November report and order are 28.2-28.3, 50.06-50.08, 144.05-144.06, 220.05-220.06, 222.05-222.06, 432.07 - 432.08, and all Amateur frequencies above 450 MHz. Manual control (attended) beacons are permitted on all Amateur frequencies. Beacon transmitters are limited to 100 watts input under the new rules, which become effective January 3, 1983.

ARRL ASSUMPTION OF THE EXAMINATION PROGRAM as proposed in its late October petition is believed to be seeing some modification by the League itself during the comment period, which closed November 29. The League's Executive Committee has also agreed to ask the Commissioners to delay consideration of a no-code license for 18 months, in order to avoid injecting such a controversial issue into the already complex problems that Amateur administration of the exam program is certain to create.

Whether Or Not The League's Exam Proposal becomes the basis of the new exam process, the Commission's own timetable, as well as financial considerations, seem to insure that the transfer will have to be accomplished by next fall.

Amateur Participation In Monitoring And Enforcement activities could well precede our taking over the examination program. ARRL's Interference Task Force has been working on the details of a cooperative effort between FCC's Field Office Bureau and Amateur volunteers for some time, and with minor revisions in the well-established 00 program it could be up and running in a few months. Much of such a program would be "advisory" to individual Amateurs, as with present 00 notices. However, with respect to deliberate violators, the volunteer monitors' job would be to make it as easy, quick, and inexpensive as possible for the Commission enforcement staff to build an effective case against a flagrant violator.

FCC'S NOVICE EXAM PROPOSAL to permit the examiner to create and grade the written as well as code portions, PR Docket 82-727, has comments due February 15, reply comments March 15. Comments On The FCC's Logbook Elimination Proposal, PR Docket 82-726, are due by January 14. Reply comments on that item are due February 14.

In A Related Move, The FCC Has Dropped The Requirement that stations in the Aviation Services maintain logbooks.

A NEW RUSSIAN SATELLITE, ISKRA 3, WAS LAUNCHED November 18 from the Salyut 7 spacecraft. At presstime only CW telemetry on its 29.583-MHz beacon had been heard from Iskra 3, which is believed to carry a 21.23-21.27 MHz in, 29.58-29.62 MHz out transponder like its predecessor, Iskra 2. Iskra 3's altitude is about 360 km, and period 91.6 minutes.

Phase IIIB's Launch Is Now Definitely Set For Next April on Ariane's L6 launch. In addition, the Air Force has responded favorably to a proposal that Phase IIIC be given a ride on an Air Force launch some time in 1984. As a result, AMSAT's budget is being stressed severely. Members are strongly urged to renew their memberships promptly. Some worthwhile AMSAT goodies are still available; Box 27, Washington D.C. 20044 has details.

1983 OSCAR Orbital Prediction Calendars that include RS-5 through 8 as well as OSCAR 8 are now available from Project OSCAR, Box 1136, Los Altos, California 94022. U.S. postpaid price is \$10; they're \$12 overseas.

FINAL WARC IMPLEMENTATION COMMENTS ARE BEING SOUGHT by the Commission in an NPRM adopted at its November 18 agenda meeting. The actual 300-page document and comment due dates should be released by mid December, but those areas of most interest to Amateurs are final rules for 10 MHz, availability of 18, 24, and 902 MHz, and moving the frequency below which CW ability is required down to 30 MHz. No surprises are expected in the Amateur Radio portions of General Docket 80-739; a 60-day comment period is expected.

ELIMINATION OF CB LICENSING IS EXPECTED TO BE DECIDED ON by the commissioners in an early December meeting. Expectations are, that despite strong opposition from CB user groups such as REACT, requirements for both CB and radio control licensing will be dropped.

NEW THIRD PARTY TRAFFIC AGREEMENTS WITH ST. VINCENT (J8) AND GRANADA (J3) have been announced by the FCC, just in time for Caribbean winter holiday travel.

# Nampa Satellite SYSTEMS

## DEXEL Receiving Package \$2350.00

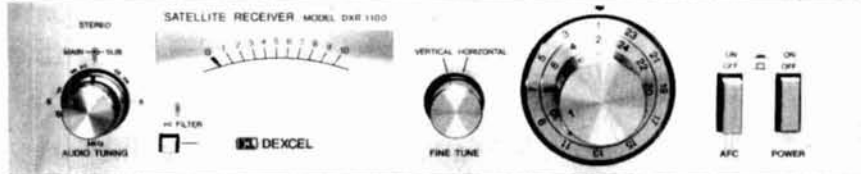

DXR 1100 Stereo Receiver, LNC and remote control 10' Prodelin fiberglass dish with Polarmount • Polatron II Electronic Polarizer and Cables

## Universal Communications Package

**\$1999.00**

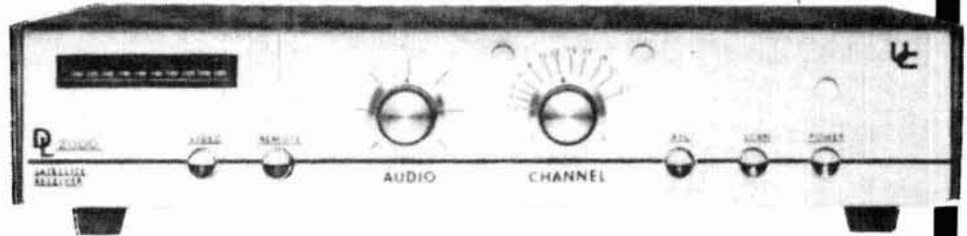

Universal Communications DL-2000 • 10' Prodelin fiberglass dish with Polarmount • Polatron II Electronic Polarizer, Dexel 120° LNA and 100' Cables

VISA and Master Card

Electronics shipped UPS prepaid - Dish and Polarmount freight collect 24 hour phone line for orders 7 days a week

**(208) 466-6727**

WB6TOC 312 12th Ave. South, Nampa, Idaho 83651

K17D

# first report on new band propagation

## Experiments and observations on the 10, 18, and 24 MHz bands

The Federal Communications Commission licensed the experimental station KK2XJM on August 25, 1981, for the purpose of conducting experiments on the 10.100-10.150, 18.068-18.168, and 24.890-24.990 MHz WARC bands. These bands are intended for Amateur use in the future. A license on these bands authorizes operation at a maximum of 30 watts ERP and 2.8 A3J emissions. [U.S. Radio Amateurs were permitted to use 10.100-10.109 MHz and 10.115-10.150 MHz, at a maximum power level of 250 watts with A1 or F1 transmissions, as of October 28, 1982, at 3 p.m. Eastern Daylight-Saving Time.]

One main reason for the experiment on these bands was to gather and analyze reports received from (mostly Amateur) listening stations. The analysis techniques we used, and the results obtained from the reports, are presented in this article.

Because the results of the experiment depended greatly on listener response, we generated and distributed publicity announcing the experiment and its authorization by the FCC, and we described the information needed from listeners and how it should be reported. This publicity was followed at intervals by detailed schedules of our broadcasts. *QST* and *World Radio* published the complete announcement, *ham radio* covered the information in an editorial, and extracts and schedules were also published in *73*, *CQ*, *Florida Skip* (a regional magazine), and several local club newsletters.

The response we received from listening stations was encouraging. Many people phoned or sent letters, requested schedules, asked for information on the equipment to be used, and wanted to know how to provide reception reports.

### preliminaries

Before starting the experiment, we conducted a number of sweeps on the 10, 18, and 24.5 MHz bands to determine signal levels and types and to select operating frequencies. Fig. 1 shows a result typical of these scans. Signals are shown as blocks for teleprinter, multi-channel signals, and voice or music, and as lines for unmodulated carriers. Some of the carriers represent no-information transmission periods of stations that were active at other times. We found gaps at times, but all frequencies on 10 MHz were in use at some period of the day.

Conditions were similar on 18 and 24.5 MHz, but the average number of stations on the air was lower, and periods of heavy use were shorter. It was not uncommon to find only six signals on these bands, half with no modulation.

A better picture of band use developed as the experiment progressed. Spectrum scans were made by W1RN at the ARRL Lab in Newington, Connecticut, as an aid. A pattern of full occupancy during others was evident; we also noted that a few signals were very strong, but there were long periods when most signals were not much above the noise level.

We couldn't identify all the signals present; stations appeared without identification, transmitted coded signals by voice or CW, and then disappeared. We didn't try to copy teleprinter signals, which alternated as keyed or non-keyed carriers without Morse transmissions.

After studying the scan results, we scheduled initial operations on 10.140, 18.108, and 24.930 MHz. These are each 40 kHz above the low edge of the WARC bands. This uniformity was actually a low priority; the prime consideration was to avoid frequencies occupied either by very strong signals or by any signals most of the time. And we wanted to select frequencies most likely to be detected by typical Amateur installations, as well as those on which interference would be a likely problem. Determining the interference potential to existing band users by an Amateur signal was one of the main reasons for conducting this experiment.

By R.P. Haviland, KK2XJM (W4MB), 2100 S. Nova Road, Box 45, Daytona Beach, Florida 32019

Although it soon became clear that there was no real reason to use frequencies other than those first selected, it did appear that some attempt should be made to simulate the Amateur condition of no assigned frequency. We did this by introducing a small offset from the selected frequency. Normally the offset was kept to a fraction of a kHz, but we did use a few offsets of up to 5 kHz.

### experimental equipment configuration

The equipment we used is summarized in fig. 2. The transmitter is an SBE 33, using new band crystals, and rf coils paralleled by additional inductors to provide the necessary tuning range. The tune circuit was modified to provide an adjustable carrier level and to permit switching or keying.

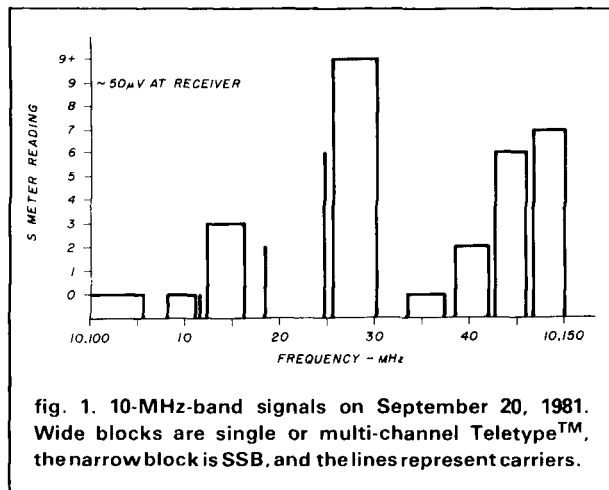

fig. 1. 10-MHz-band signals on September 20, 1981. Wide blocks are single or multi-channel Teletype™, the narrow block is SSB, and the lines represent carriers.

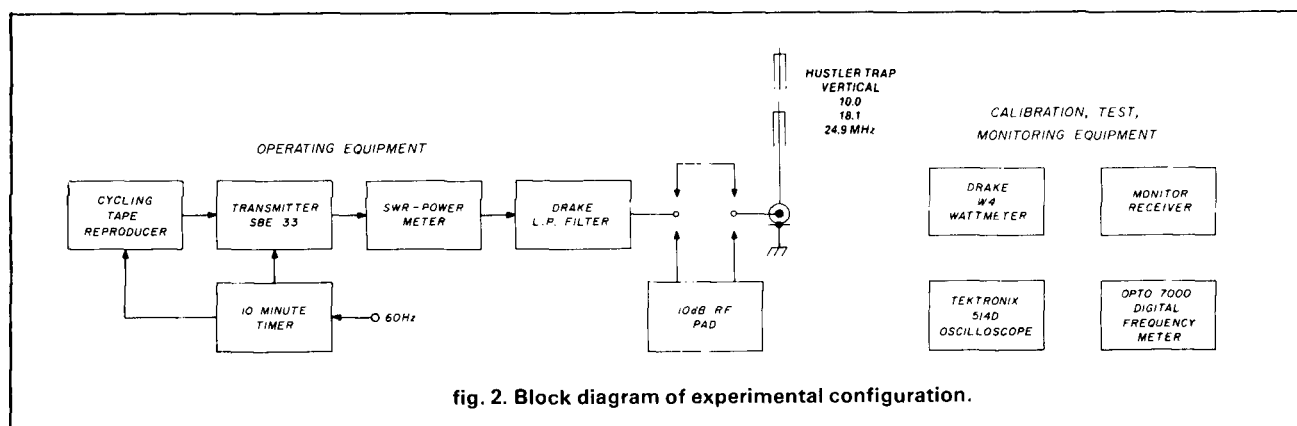

fig. 2. Block diagram of experimental configuration.

We retuned the antenna, a commercial (Hustler) trap vertical, to the center of the WARC bands by adjusting the capacity sleeve of each trap. Section lengths were adjusted for minimum SWR at the selected frequencies. The antenna was mounted at the center of a 36 × 56 foot metal roof. The ground connection to the roof was primarily capacitive: a screen approximately three feet square with six end-terminated radials eight to thirty feet long. An rf check of the roof showed essentially uniform current distribution at the perimeter.

The transmitter operation was controlled by a ten-minute timer, the minutes indicator of an experimental digital clock. We used a nine-minute carrier followed by one minute of identification by USB voice. The identification was made by a recorded voice announcement of fifteen or thirty seconds' duration on an endless tape. For ease of copy, the XYL (W4LDY) made the tapes. The identification tape was not locked to time.

We monitored power and frequency continuously. A 10-dB pad (2-watt carbon resistors in oil), was inserted in the transmitter output for low power. This also served as a dummy antenna.

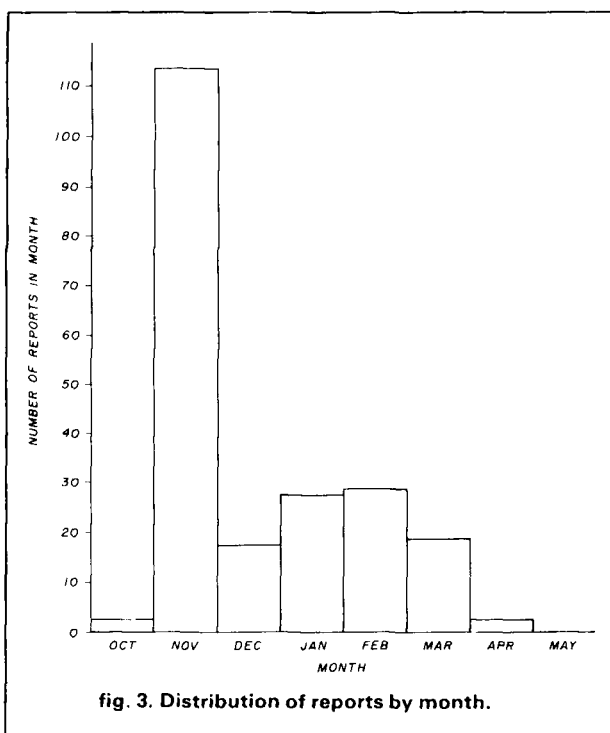

fig. 3. Distribution of reports by month.

Band use and emitted signal quality were monitored by a transceiver, originally a Kenwood TS-820, later a TS-830. We began operating on October 3, 1981, at a power level of 3 watts ERP on 10.140 MHz. The signal was a single steady carrier interrupted every ten minutes, beginning at two minutes past the hour, by a voice announcement. We operated continuously from October 4 through October 12, and then for seventy-two hour stretches (Friday through Sunday, UCT) beginning October 19 and continuing till September, 1982.

We increased power to 30 watts on November 3, and instituted a regular rotating schedule for operations on all bands on December 2. During our first four weeks on the new bands, operation was also on 3 watts ERP, rising to 30 watts ERP thereafter.

### quantitative results — general

A total of 168 individual reports were received. Of these 131 were for a single time and frequency. The remaining thirty-seven were for multiple times, up to approximately thirty. The total data base consists of 274 entry items: this number is smaller than we'd hoped for, but good enough to give reasonably accurate results.

The distribution of reports over time is shown in fig. 3. The small number received in October is a result of low power and a lack of publicity. Changing these factors resulted in a great increase in the number of reports for November. Thereafter, we believe the novelty of reporting was gone, and only the truly dedicated have continued to report. All reports are acknowledged with a special QSL card.

### quantitative results — effect of times

The distribution of reports correlated with time of

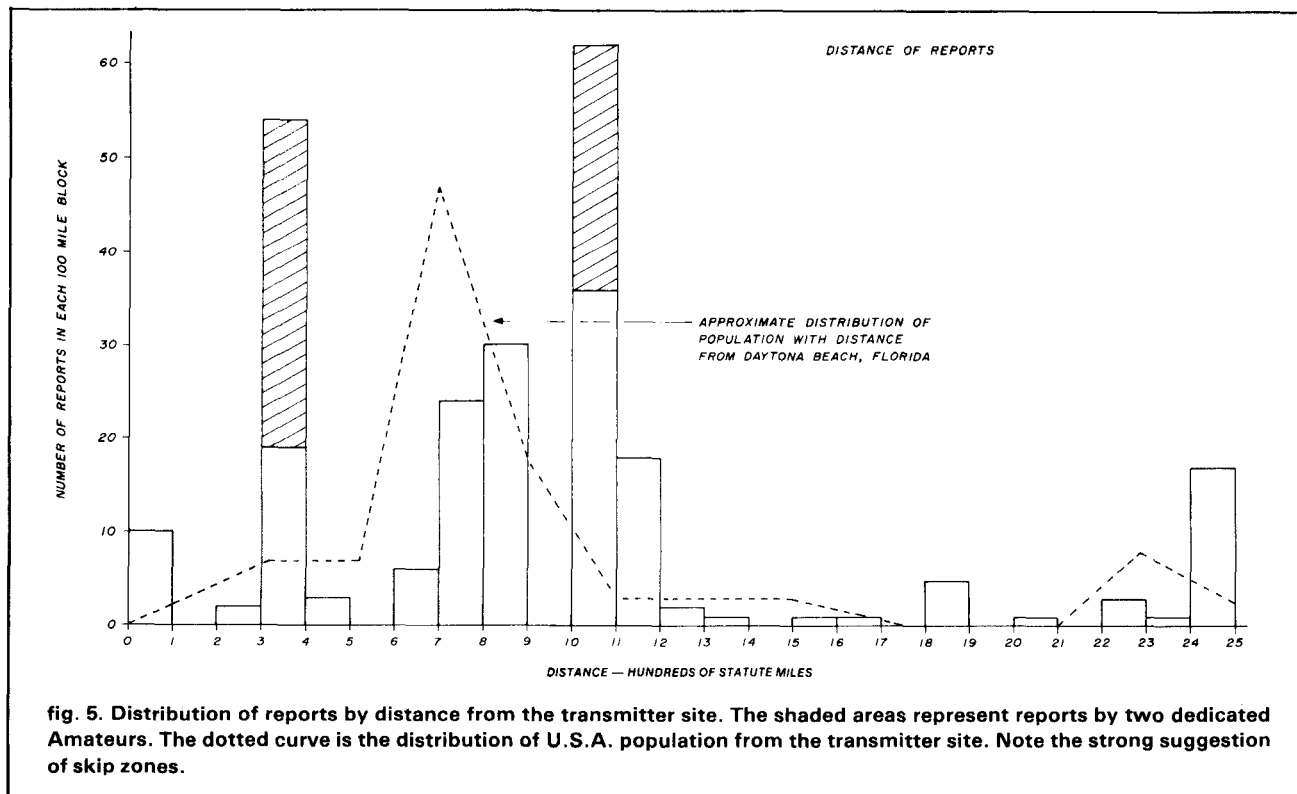
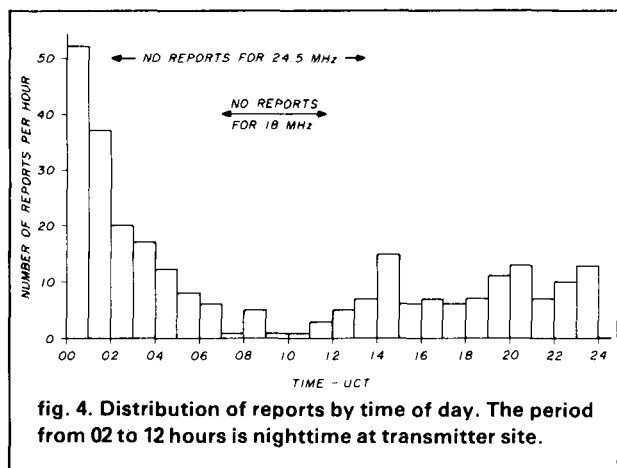



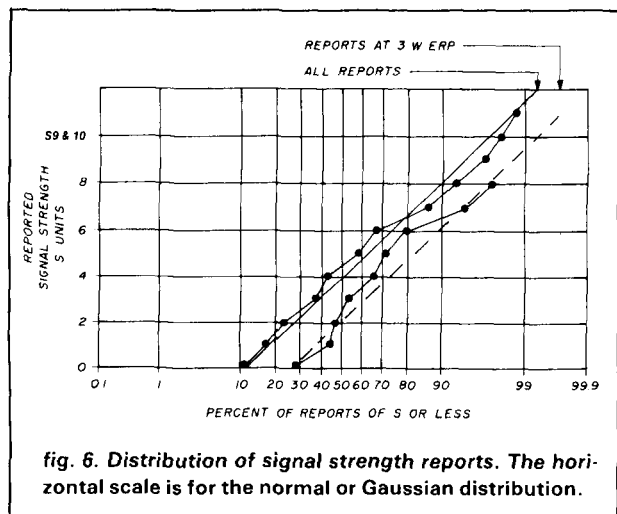

day is shown in **fig. 4**, by block for each hour. The reason for the large number of reports at 00-01 hours UCT appears to be that those hours are good for listening (early evening for the U.S.A.) — and also improved propagation at 10 MHz. The low between 07 and 11 hours UCT is understandable, since most listeners are sleeping, and propagation during those hours on 18 and 24 MHz is not as good, as indicated by the no-report bars. The number of reports on these bands, however, is not a major factor in the overall distribution.

The curve indicates that the 10-MHz band will be usable almost twenty-four hours a day during part of the solar cycle. The band at 24.5 MHz resembles 10 meters in performance, being dependent on daylight and high solar activity.

### quantitative results — distance effects

The number of reports as a function of distance is shown in **fig. 5**; the reports are separated into zones one-hundred miles wide. (Note that in two of these zones, from one-third to two-thirds of the report entries are from a single Amateur station. The influence of this repeated reporting can be estimated by disregarding the cross-hatched areas of the bars at 300-400 and 100-1100 miles.)

The data strongly suggests the presence of skip zones, with maximum signal strength at 350, 950, 1850, and 2450 miles. This finding, however, could be the result of uneven population distributions. To check this, we calculated the distance from the transmitter to each state capital (we assumed that the largest population concentration of the population of the state is at this distance). The population distribution that results is shown as the dashed curve

in **fig. 5**. (While a distribution of Amateurs with distance would be more representative, the percent of Amateurs and shortwave listeners does not appear to vary widely from state to state.)

Comparing the population and report distributions confirms that skip processes are at work here. The block at 350 miles appears to correspond to one-hop (sporadic) E, those at 950 and 1850 to one and two-hop E, and the block at 2450 miles possibly to three-hop E, but more likely to one-hop F-layer propagation. These reports are for all the bands, but they are dominated by 10-MHz reports. The number of reports at 18 and 24.5 MHz were too few to permit the evaluation of the effects of distance.

### signal strengths

The distribution of signal strength reports is summarized in **fig. 6**. For all reports on all bands, the median signal report is approximately S4, and nearly fifty percent of the reports fall between S2 and S6. This distribution approximates the normal, or Gaussian curve, very closely, although in principle the curve is bound at the low signal end and essentially unlimited at the upper.

Reports at the three-watt input level are also plotted, and lie almost exactly two S-units, or a nominal 10 dB, below the curve for each. The number of reports at this power level is not, however, sufficient for a really good estimate to be made.

The signal strength distribution over the three bands is shown in **fig. 7**. The median signal on the two higher bands lies approximately one S-unit below signals at 10 MHz, and shows somewhat greater propagation variability. Under strong signal condi-

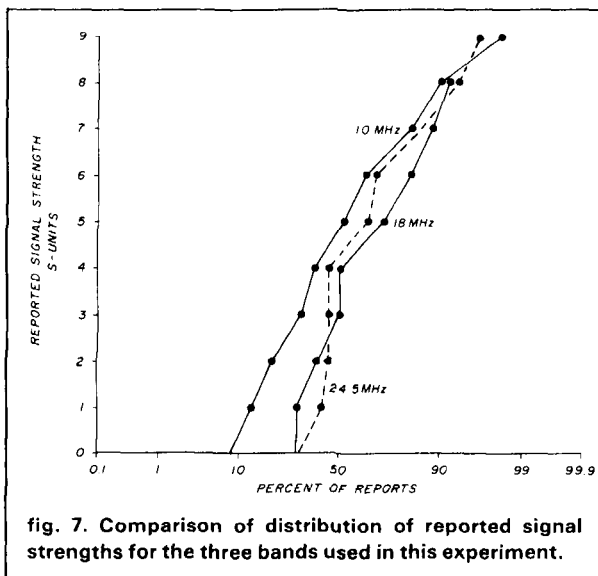

fig. 7. Comparison of distribution of reported signal strengths for the three bands used in this experiment.

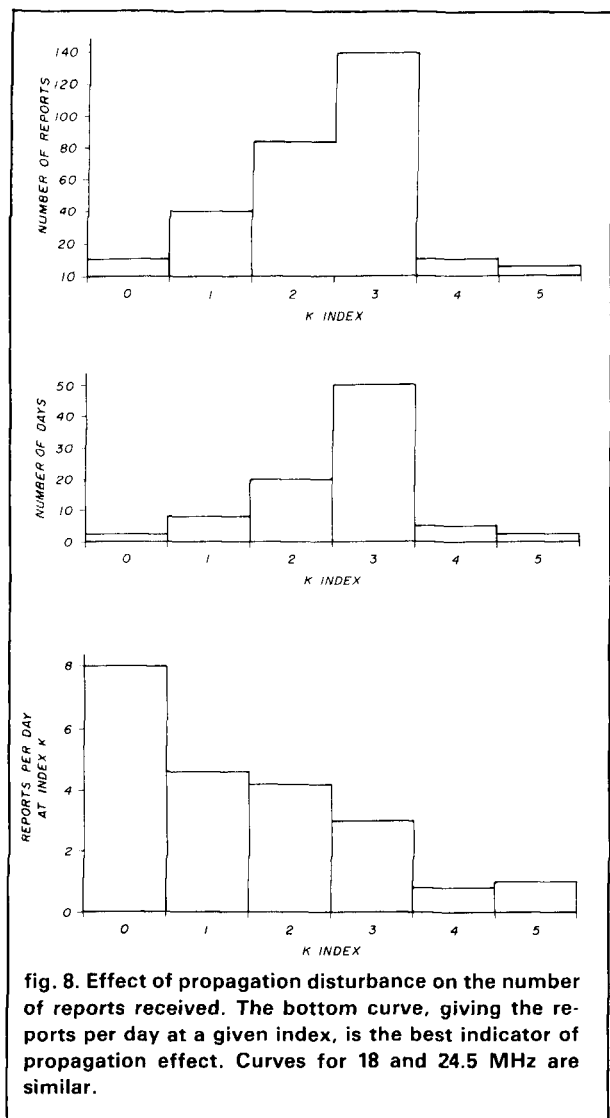

fig. 8. Effect of propagation disturbance on the number of reports received. The bottom curve, giving the reports per day at a given index, is the best indicator of propagation effect. Curves for 18 and 24.5 MHz are similar.

tions, however, levels on all the bands are essentially the same.

These observations suggest that signals on 10 MHz are less affected by most propagation disturbances than will those on the higher bands. (This is also noticeable on 14 MHz, when compared with 21 and 28 MHz.) Considerably more data is needed, however, to confirm this factor. Listening stations' use of less efficient antennas (than a resonant half-wave) might account for the lower signal levels reported.

### solar and geomagnetic activity

The National Bureau of Standards' K index was used to measure propagation conditions. Although there were a few periods of very good or very poor propagation, the general conditions ranged from average to below average.

The effect of propagation conditions at 10 MHz is shown in fig. 8. The largest number of reports received were for  $K = 3$ , with a very few reporting  $K$  exceeding 3. The ratio, or number of reports per day of a given index, appears to be a better measure of the effects of propagation. The bottom chart shows this, and indicates a marked decrease in the number of reports received as the  $K$  index increases. In comparison with the excellent conditions ( $K = 0$ ), average conditions ( $K = 2$ ) reduce the number of reports to one-half, and poor conditions ( $K = 4-5$ ) reduce the number to around one-eighth.

The pattern for the 18 and 24 MHz bands is similar, with a greater reduction in reports as propagation becomes poorer. This reduction corresponds to subjective observations on the effects of poor conditions.

The effects of conditions on signal strength are shown in fig. 9. Three conditions are adduced: excellent, average, and poor, which correspond to  $K$  index values of zero, 1-3, and 4 or more, respectively. Signal level differences of 1 to 1.5 S-units between groups are indicated. (Separate observations suggest that F-layer propagation is very poor at  $K = 4$  and E-layer at  $K = 5$  or greater. Many more observations are required to separate out the various propagation effects.)

### receiving equipment

In general, the receiving equipment used by reporting stations was not as sophisticated as the average Amateur band receiver. Most receivers were either all-band receivers, often of the WW II class, or recent-model receivers with WARC band provisions. However, that is not considered to have been a major factor in signal reception.

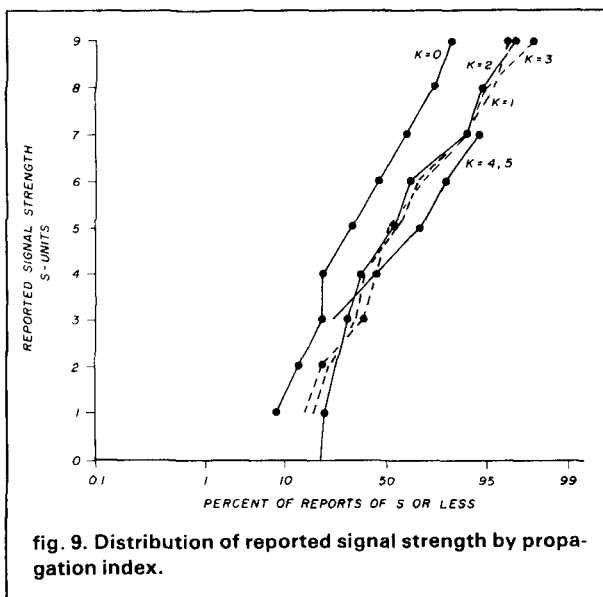

fig. 9. Distribution of reported signal strength by propagation index.

Antennas used by reporting stations (not always optimized for the new bands) included:

inverted-V	76
multiband dipoles	49
long wire	31
verticals	19
wire, (not long)	12
Yagi beams	11
quad-delta beam loops	4
indoor antennas	4

Of these, the long wire and multiband dipoles, and possibly the inverted vees, can show gain, but the rest will give near isotropic performance or worse. For example, the long wire antenna reports were about one S-unit stronger, on the average, with half the reports between S3 and S7. The other half of all reports were between S 1.9 and 6.1, indicating a 5 dB gain for the wire antennas. This suggests the average antenna used in reception was not far from zero dB gain. Indoor antennas could easily be twenty or more dB below isotropic.

Studies reported in *Ham Radio HORIZONS*, July, 1980, page 18, indicate that few Amateur stations on the high-frequency bands use antennas of essentially dipole gain. The average station uses a beam of about 7-8 dB gain, a three-element Yagi or equivalent. Combined beam plus height may run to 15 dB or so for exceptionally equipped stations.

These factors indicate that signal reports in a well-established Amateur Service on these bands will be higher than reported here, resulting from improved equipment alone. The antennas likely to be used would be loaded two or three-element Yagis, showing an effective gain of about 5 dB. Accordingly, it appears that our results should be adjusted upward by about 5-7 dB when applying them to typical (future) operational conditions.

## interference

Evaluating interference is an important part of this experimental program. First, interference caused by the experimental station to existing users: No reports of interference to an existing band user were received. This is not surprising; it was the predicted result. In fact, the power limit of 30 watts ERP was set to give a 10-dB margin over the "negligible risk of interference" point of typical existing services, based on CCIR values of required S/N, error rates, fade margin, and typical installation. That no interference has been reported is a good indication that calculated interference values are at least reasonably close to experienced values.

It should be noted that operating frequencies were chosen to be in a low occupancy, but not clear, part of the band, just because of the need for interference data. That this was an effective choice is shown by

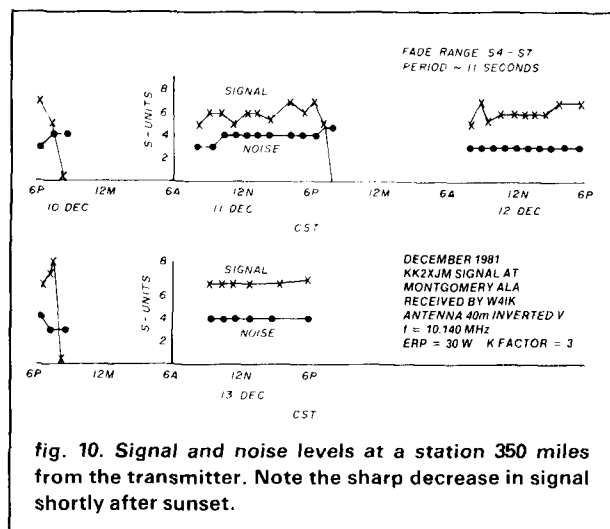

fig. 10. Signal and noise levels at a station 350 miles from the transmitter. Note the sharp decrease in signal shortly after sunset.

the fact that over twenty percent of the reports indicate interference to the experimental signals by existing users.

The relationship between signal, noise, and interference is summarized in fig. 10. It shows typical signal and noise levels for a 10-MHz signal received via one-hop E transmission. A decrease in signal strength at sunset is notable. Even at this short distance, 380 miles, the maximum S/N ratio was no more than 30 dB, the usual value being 10-15 dB. Signal levels at this distance should be regarded as marginal for SSB, good for CW.

The interference potential is illustrated in fig. 11, which shows a reported band scan for a period of no beacon operation, start-up, and sunset fade. At no time did the maximum beacon signal exceed the level of adjacent signals, being 2-3 dB lower under best beacon-signal conditions. The sunset fade did change the levels of adjacent stations somewhat, when compared with earlier conditions, but the effect was very small compared with that on the beacon signal. (The other signals present were not identified. Since the strength did not usually change appreciably at sunset, they might have arrived via the F layer.)

## other experiments

The experimental program described here is one of several in progress. Other stations involved are these:

KK2XGH	Silver Springs, Maryland
KM2XDU	Rye, New York
KM2XDW	Menlo Park, California
KM2XDX	New York, New York

Experimental transmissions are continuing. Major changes that have been made at KK2XJM are power increase to 100 and 300 watts ERP, and scheduling

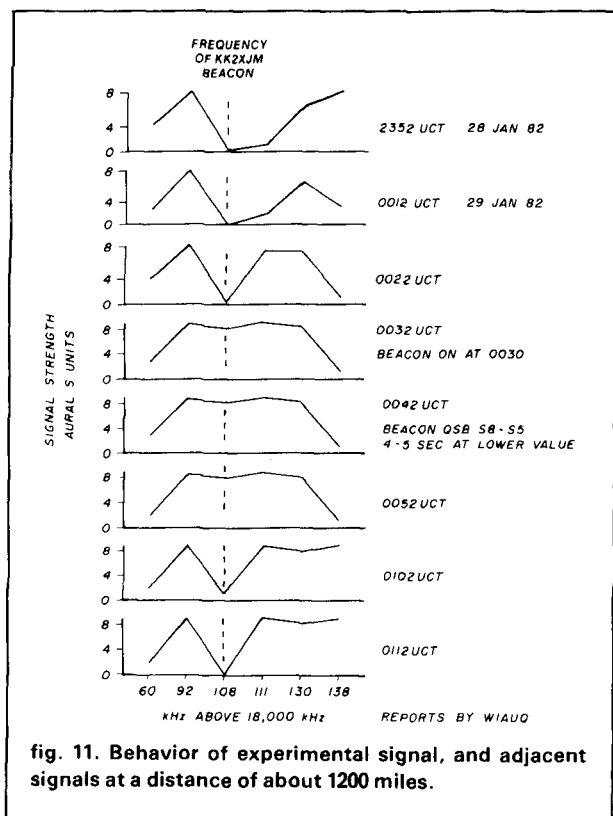

fig. 11. Behavior of experimental signal, and adjacent signals at a distance of about 1200 miles.

band use to approximate the OWF to selected areas. Test results have not yet been compiled for these changes.

## conclusions

Our findings are summarized by noting that no unexpected conditions occurred. Propagation effects and signal levels are mostly very close to the predicted average values. One possible conclusion is that a viable and reliable international (greater than 2500 miles) Disaster-Emergency Communication Service\* on 10 MHz cannot be established using SSB at 30 watts ERP. This is clearly shown by the paucity of international reports, by the low S/N ratio at 1100 miles and low signal level at 2500 miles under average conditions, and by the lack of service reliability.

This finding confirms the propagation calculations we filed with the experimental license application. These show, for just usable service, operator to operator, average conditions, with a dipole receiving antenna, the following transmitter ERP requirement:

path	time	mode	power, CW	power, SSB
London-Azores	Sunset	E-layer	0.4 W	26.3 W
Washington-Paris	Noon	F-layer	8.2 W	213.8 W

\*The benefits of such a service was a major factor in securing these new bands as an Amateur allocation.

For a reliable service, power should be increased by about 10 dB for quality, by a further 10 dB for fade margin, and by another 6 dB for worldwide paths.

It appears that power levels of 1500 watts ERP are needed for reliable worldwide CW disaster/emergency service with dipole antennas (typical of emergency conditions). The level could be reduced to about 300 watts if inter-station relay or a beam antenna for reception were used. A highly reliable worldwide SSB emergency service appears to require unreasonably high powers, although a useful regional service could be established with powers of 200-600 watts ERP.

A second conclusion is that a power level of 30 watts ERP, either A0 or A3J, is below the level which would cause harmful interference on the 10 MHz band. This finding confirms interference calculations. For example, consider a path with 1000 km E-layer winter night propagation, a total of ten interfering signals per 0.3 kHz (CW) or 2.8 kHz (SSB), and CCIR recommended performance. For a signal service reliability of 99.99 percent (FSK) or ninety percent (commercial voice), the allowable ERP of each interfering station is:

situation	CW/CW	CW/SSB	SSB/CW	SSB/SSB
wanted/unwanted allowable ERP	154 W	912 W	309 W	1830 W

The allowable radiated interference level varies roughly as the square root of the number of stations of equal power (or as the RMS equivalent if different power), due to statistical variations, in modulation, timing, arrival phase and path attenuation. Interfering signal power could be increased about 20 dB at noon. A 10-dB increase in the allowed interference level would reduce service reliability of the desired signal to about fifty percent.

The fact that SSB emissions may be allowed higher power has surprised some. This is due in part to the difference in duty cycle: -17 dB assumed for the normal voice versus -3 dB for average CW. Another difference is in the effect of the number of signals present in the passband, and the percentage of the total radiated power accepted by the receiver. In a service with distributed interference sources and random frequency use, the measure of interference potential is power per unit of bandwidth. Emitted bandwidth alone is not important.

Several weeks of operation at 100 watts and 300 watts ERP have passed since the period this report was based on, again with no reports of harmful interference. This offers further confirmation of the above evaluation. Additional results will be reported on later.

ham radio

# a fixed-tuned LF converter

An add-on project to  
let your 80-meter receiver  
explore new worlds

Many commercial and military signals can be received by using this simple converter. It is compatible with most commercial transceivers where a direct frequency readout of the 80-meter band is displayed on the tuning dial. A block diagram of the system is shown in **fig. 1**. For digital-readout transceivers, read the frequency by subtracting 3.5 MHz. The converter covers as low as 3 kHz and up to 240 kHz, the low-end cut-off frequency being determined by the receiver used as a tunable i-f (see **fig. 2**).<sup>1</sup>

## the circuit

Parts for the converter were available in my junk box and through local distributors such as Radio Shack. The converter is designed to be operated with a long wire antenna, 100 feet or greater, although results have been fairly good with shorter wires (with some sacrifice in weak-signal reception). An active antenna can be used to increase sensitivity.

As shown in the circuit diagram, **fig. 3**, the input circuit is a six-element Chebyshev lowpass filter which is directly coupled to the FET mixer,  $Q_1$ . The CR1 and CR2 diode arrangement protects  $Q_1$  from strong transients such as those created by lightning. The local oscillator is a simple 3.5-MHz Pierce crystal oscillator. An output match to the receiver is provided by an emitter follower,  $Q_2$ . Total current drain is less than 3 mA. A 9-volt transistor battery can provide over one year of service under normal use. No degradation of operation was observed even when the battery output dropped to 4.5 volts.

## construction

The complete converter, including a 9-volt transistor battery, is mounted in a standard  $5 \times 2\frac{1}{2} \times 1\frac{1}{2}$ -inch ( $130 \times 65 \times 39$  mm) utility box. A BNC connector can be used for the i-f output (I used a readily available SMA connector), and a standard banana jack serves for the antenna input. Circuit layout is not critical — a  $2 \times 3$ -inch ( $51 \times 76$  mm) perf-board can be used for component mounting.

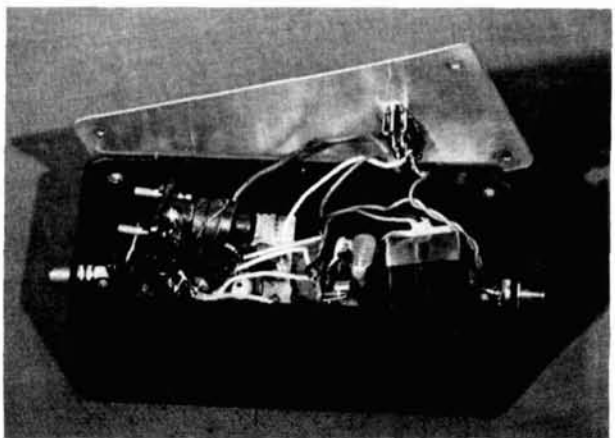
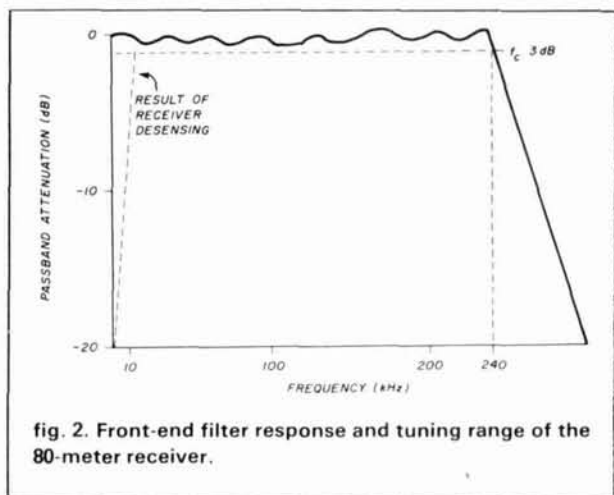
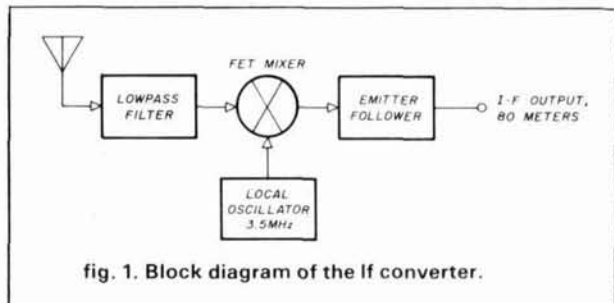

The perf-board and components easily fit into a small utility box with plenty of room for a 9-volt battery.

By S.J. DeFrancesco, K1RGO, 17 Jeffrey Rd.,  
East Haven, CT 06512

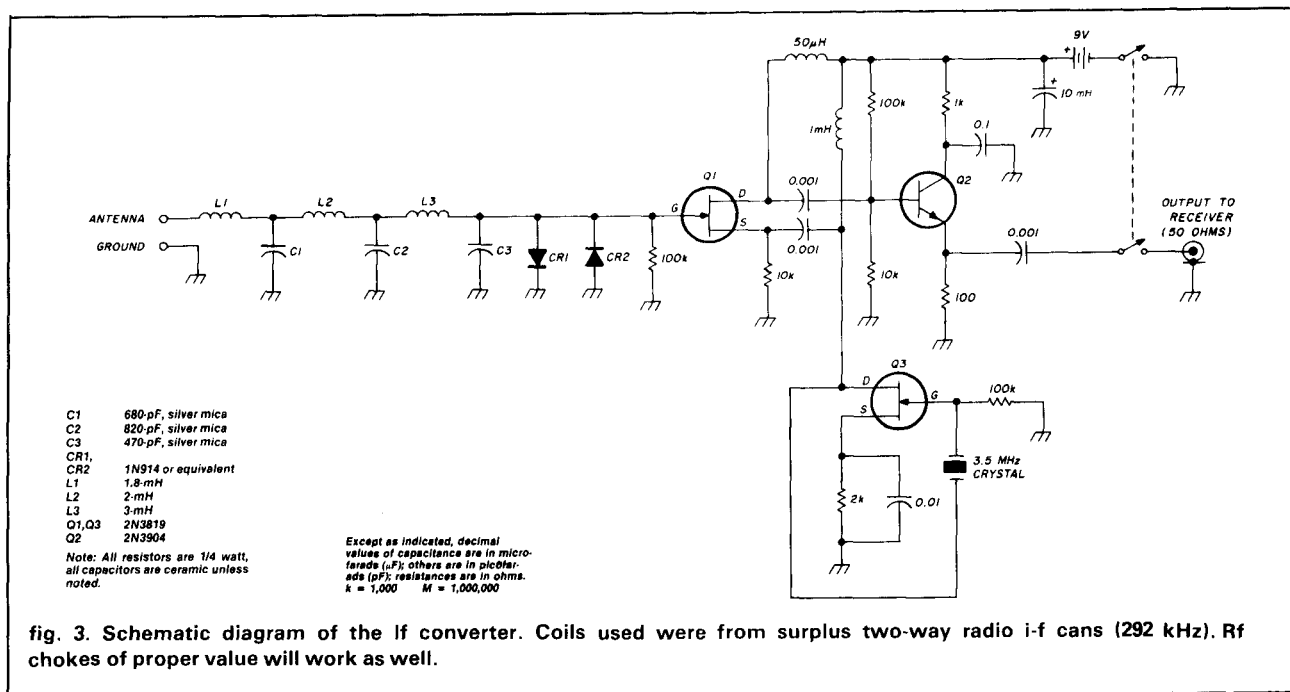

fig. 3. Schematic diagram of the If converter. Coils used were from surplus two-way radio i-f cans (292 kHz). Rf chokes of proper value will work as well.

table 1. Some signals that have been heard from the East Coast in the LF Spectrum.\*

Frequency	Station	Location
12 kHz	OMEGA	—
16-17 kHz	JXZ, GBY	Norway
60 kHz	WWV time signal	Colorado, USA
100 kHz	Loran C	—
120-150 kHz	TTY, CW, Military	East Coast, USA
150-180 kHz	Foreign broadcasts	Mostly European
160-190 kHz	1 watt experimental beacons	East Coast, USA (beacons received over 200 miles)
192 kHz	SFI	San Francisco, CA
194 kHz	TUK	Block Island, RI
215 kHz	CLD	—
233 kHz	GN	—
240 kHz	MMK	—

\*Editor's note: For those interested in studying low-frequency propagation, a good source of frequency and station-location information is the Sectional Aeronautical Chart used by aircraft pilots. Some of the non-directional beacon stations are on frequencies as low as 200 kHz, and they operate continuously. All have an identifier (usually on CW), and some provide local wind, weather, or air-traffic information by voice announcements. Go to your nearest airport and ask the FBO (Fixed-Base Operator — he sells/rents/services small planes) for the VFR chart that covers your area. Get one with a scale of 1:500,000. Each chart has a guide to adjoining areas, so you can pick up enough to cover a large part of the country for a small fee. If you are not familiar with the terms used on the chart, ask the FBO to point out a couple NDBs for you. They are usually indicated by a dot, surrounded by a circular dotted area, and have the location/frequency/identification legend enclosed in a nearby rectangular magenta-colored box.

## evaluation

I have obtained very good results using the Yaesu FT101EE receiver and my 160-meter antenna (260-foot long wire). The antenna is connected directly to the input of the converter, and the auxiliary antenna input on the Yaesu is connected to the converter's i-f output. Light-dimmer noise is greatly reduced by the noise blanker in the Yaesu, making perceptible most of the weak signals that were otherwise masked by the noise.

In the 0 to 12-kHz portion of the spectrum, which was at one time used for missile detection, you can hear 60-Hz power-line harmonics, as well as whistlers, chirps, and pops caused by atmospheric phenomena. Some of the activity, starting from 12 kHz (3.512 MHz on your receiver) to 240 kHz, is shown in table 1. Low power (1-watt CW) experimental beacons and QSOs can also be heard in the 160-190 kHz band. I have heard HS, Fairfield, CT, 165 kHz; FY, Long Island, NY, 186 kHz; KEN, central NJ, 185.6 kHz; BIL, central NJ, 185.9 kHz; and WI in Owings, MD, 186.2 kHz. All signals were very readable (depending on local noise conditions, of course).

## reference

1. *Handbook of Electronics Calculations*, Kaufman and Seidman, Filter Design Chapter.

ham radio

# Introducing Corsair



## A New No-Compromise HF Transceiver

The CORSAIR is an extraordinary new HF transceiver. Every function operates without compromise. New unique features make it a delight to operate.

A new front end provides extreme sensitivity, low internal noise and high dynamic range to bring weak signals to life. For even greater overload prevention, the integral rf preamplifier can be switched out. More effective than the usual rf attenuator.

The filtering system, a TEN-TEC exclusive, virtually switches to privacy. It starts with a superb 2.4 kHz 12-pole ladder sideband filter system, standard. It provides variable bandwidth for ssb, great for today's crowded phone bands. A novel pass band tuning circuit allows a received signal to be moved within the pass band to its optimum position with respect to QRM. Optional narrow band filters are available for ssb, cw and RTTY, all switched from the front panel. The ultimate in QRM reduction.

Full cw break-in opens a window on the band while transmitting, turning monologues into conversation. Or, if conditions dictate, just switch to semi-break-in. And no VOX adjustment when changing modes.

A versatile offset tuning system allows the receiver and transmitter to be tuned separately with a  $\pm 1$  kHz range for fine tuning or  $\pm 4$  kHz for working off frequency. For net operation, both can be moved simultaneously.

Reliability is designed in. The CORSAIR system is so rugged it will operate into infinite SWR. And we guarantee it unconditionally (except for lightning) for one year. The CORSAIR is designed for 100% duty cycle, ideal for RTTY, SSTV and of course, contests.

Beauty is more than skin deep. The contemporary styling with the blackout LED frequency display (last digit in green), the baked-on textured bronze/black finish with aluminum trim will retain its handsome appearance permanently. Beneath its sleek exterior is a carefully crafted chassis packed with performance.

There are many other features, each with superb performance. An effective speech processor, notch filter, adjustable noise blanker, signal spotter, three position AGC, threshold ALC, simplified VOX, all controlled from the front panel. In addition, the CORSAIR has a compression loaded speaker, less than 2% audio distortion, and full accessory connections including remote bandswitch output. It even has a volume equalizing headphone output.

The CORSAIR is a total system of pure operating pleasure—it really must be put through its paces to be fully appreciated. Its smooth controls, comfortable and logically spaced, give it the feel of a superlative transceiver. One that will be a faithful companion for the years ahead.

All TEN-TEC products are completely manufactured in the U.S.A., in the foothills of the Great Smoky Mountains.

Model 560, CORSAIR transceiver . . . . . \$1169.  
See your TEN-TEC dealer or write for full information.

**TEN-TEC, INC.**  
SEVIERVILLE, TENNESSEE 37862

# hy-gain

## ANTENNA ROTATORS

for your peace of mind.

Determine the total wind-load area of your antenna(s), plus any antenna additions or upgrading you expect to do. Now, select the matching rotator model from the capacity chart below. If in doubt, choose the model with the next higher capacity. You'll not only buy a rotator, you'll buy peace of mind.

ANTENNA WIND-LOAD CAPACITY		
ROTATOR MODEL	MOUNTED INSIDE TOWER	WITH STANDARD LOWER MAST ADAPTER
AR22XL or AR40	3.0 sq. ft. (.28 sq. m)	1.5 sq. ft. (.14 sq. m)
CD45 II	8.5 sq. ft. (.79 sq. m)	5.0 sq. ft. (.46 sq. m)
HAM IV	15.0 sq. ft. (1.4 sq. m)	N/A
T <sup>2</sup> X	20.0 sq. ft. (1.9 sq. m)	N/A
HDR300	25.0 sq. ft. (2.3 sq. m)	N/A

For HF antennas with booms over 26' (8 m) use HDR300 or our industrial R3501.



Full details at better Amateur dealers or write:

**TELEX hy-gain**

TELEX COMMUNICATIONS, INC.

9632 Jericho Ave. So. Minneapolis, MN 55420 U.S.A.  
Europe: Le Boncoin - Office 711, Centre Affaires Paris Nord, 93103 La Plaine-Montfermeil, France

## technical forum

Welcome to the *ham radio* Technical Forum. The purpose of this new feature is to help you, the reader, find answers to your questions, and to give you a chance to answer the questions of your fellow Radio Amateurs. As a new feature, the Technical Forum will be shaped by the type and number of letters we receive from you. Do you have a question? Send it in!

*I am interested in developing an acoustical filter for CW. In the 1920s or early '30s, in QST, there was an article about an acoustical filter, but I have been unable to find that article again.*

*What I would like to make is an acoustical filter that I could add to ear plugs. The early QST article was just such a device. Since my ears are not the same with regard to loss, I could make a pair of filters and match the gain to each ear.*

*I realize that my problem is of a specialized nature but the subject of acoustical filters is still an interesting answer to CW filtering. — Howard O. Lorenzen, W7BI.*

Your memory is excellent. The article you are referring to appeared in the August, 1928, issue of *QST* on pages 23-29. It featured a detailed explanation of the theory behind and the operation and application of these filters. It is entitled "Acoustic Wave Filters and Audio Frequency Selectivity," by R.B. Bourne, 1ANA.

The article clearly illustrates the wealth of technical information developed fifty-four or more years ago that's still applicable to Radio Amateurs today. That is the point *ham radio* magazine was making in our December "Reflections" editorial: reflections of past achievements that should be remembered, used, and built upon.

*A few years ago I purchased a frequency meter LM14-Type 74028, built by Loral Electronics. Unlike the normal BC221 frequency meter, this unit uses one each of valve types 77, 6A7, and 76. For some time now I have been wishing to convert the unit to solid state using fets and have commenced doing so, attempting to adapt modifications to the BC221 type which uses two 6SJ7 and one K8-type valve. However, I have run into trouble in getting the variable oscillator to oscillate on the high band and am still attempting to get the crystal to oscillate.*

*No doubt over the years several ham radio operators have converted*

*the LM series with this old type of valve and I write to you to see whether any such circuit has been published in your magazine. — Harry Hendriks, VK2ZHX.*

One Amateur has reworked the same unit you have. Floyd K. Peck, K6SNO, in his article "More on Solid-State Conversion of BC-221/LM Frequency Meters," provides a solution replete with circuit and mechanical modifications. It appeared in the December, 1979, issue of *QST* on page 59. Floyd modernized his BC-221 using a 2N3819 for the solid-state VFO and MPF102 for the modulation mixer. In addition, he mounted the conversion parts in the bases of old 5-, 6-, and 7-pin tubes.

*I am using an X-band mixer in a configuration that includes a 1N23WE diode followed by a 2N5179 i-f amplifier. The best noise figure I am able to achieve is 12 dB. Do you know of a lower noise diode in the same package as the venerable 1N23? Would a new Schottky barrier diode be a direct replacement? — Hilary McDonald, Jr., N5AX.*

Several possibilities exist, but first it's necessary to mention that low-noise operation requires that the diode work into a well-matched circuit and that it be followed by a low-noise i-f amplifier. Lack of either might be contributing toward your 12 dB noise figure.

Specifically Microwave Associates specs their 1N23WE diode at 7.5 dB and their 1N23WG at 6.5 dB when operated into a well-matched circuit followed by 1.5 dB NF i-f amplifier. Finally, Hewlett Packard's Microwave Semiconductor Division specifies their Schottky barrier diode #5082-2713 at 6.0 dB under the same operating conditions and circuit. It is sold as a double-prong, type-49 package for \$32.00 in quantities of 1 to 9.

Thanks go to Jack Lepoff at HP's Microwave Semiconductor Division and John Minck at the Stanford Park Division for the information.

ham radio



# hy-gain®

## THUNDERBIRDS

**NEW BROADBAND TRIBANDERS  
LOAD NEW AUTO-TUNE SOLID STATE RIGS**

**TH5Mk2** Now you can enjoy outstanding broadband antenna performance in a size to fit most city lots. With 5 elements on a 19 ft. (5.8 m) boom, the TH5Mk2 has 4 active elements on each band. Hy-Q traps and monoband parasitic elements achieve an 8.5 dB gain and an average front-to-back ratio of 19 dB on 20 and 10 meters, and 22 dB on 15 meters. VSWR is less than 2:1 over the 20 and 15 meter bands, and from 28.0 to 29.4 MHz on 10 meters. The TH5Mk2 weighs only 57 lbs. (25.8 kg). And with just 7.5 sq. ft. (.68 sq. m) surface area, wind-loading is 190 lbs. at 80 mph (86 kg-129 km/h). In addition, the TH5Mk2 offers the same solid construction and outstanding features as the TH7DX. See common features below.

**TH7DX** The new standard of comparison for high performance broadband tribanders. Using a dual driven 7 element system, the TH7DX maintains a VSWR of less than 2:1 on all bands including ALL of 10 meters and WITH 8.8 dB gain. The unique combination of Hy-Q trapped and monoband parasitic elements produces an average front-to-back ratio of 22 dB on 20 and 15 meters, and 17 dB on 10 meters. Even with this amazing performance, the TH7DX boom is only 24 ft. (7.3 m) and the entire array is no bigger than the famous TH6DXX. Weight of the TH7DX is 75 lbs. (34 kg) with surface area of 9.4 sq. ft. (.87 sq. m) and wind-loading of 240 lbs. at 80 mph (108.9 kg-129 km/h).

### FEATURES COMMON TO TH5Mk2 AND TH7DX

- Broadband dual driven element system.
- Separate, highly efficient Hy-Q traps for each band handle maximum legal power with a 2:1 safety margin.
- Unique Beta Match assures efficient energy transfer.
- dc ground for lightning protection.
- BN-86, 50 ohm balun included.
- Preformed feed straps.
- Stainless steel hardware and compression clamps for all electrical and most mechanical connections.
- Taper swaged 6063-T832 thick-wall aluminum tubing.
- Rugged die-cast aluminum boom-to-mast bracket.
- Twist and slip proof, die-formed heavy-gauge aluminum element-to-boom brackets.
- Packaged in two boxes suitable for UPS shipment.

### CONVERT YOUR TH6DXX

For thousands of proud TH6DXX owners, we make a conversion kit that offers all the broadband advantages of the TH7DX and includes a complete stainless steel hardware package. It's easy to assemble and when completed, you have the finest triband antenna you can buy, the TH7DX.

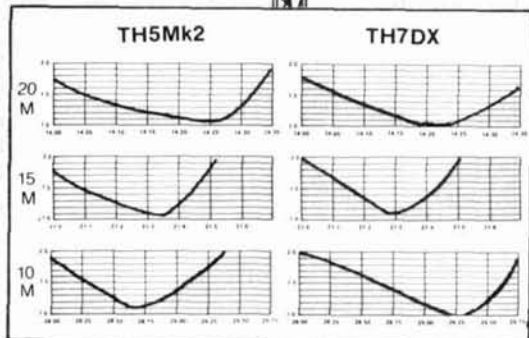
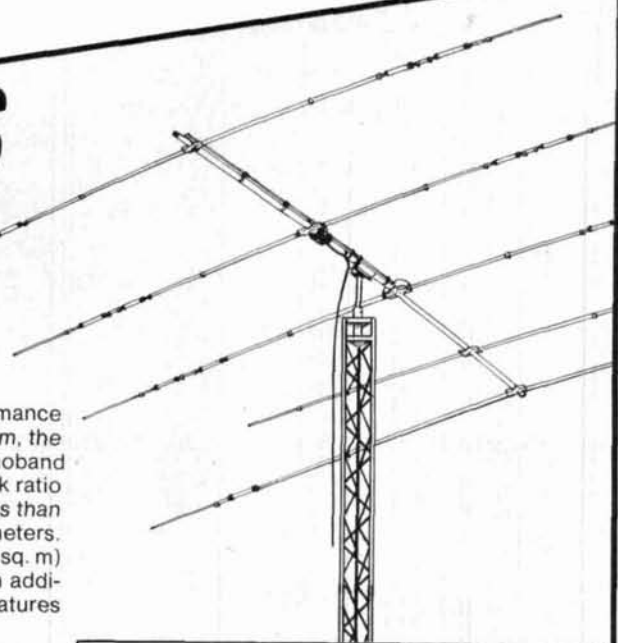

Hy-Gain's BN-86 balun and exclusive Beta Match for dc ground are included. The stainless steel hardware, rugged phasing lines and preformed feed straps permit easy assembly and consistent results.

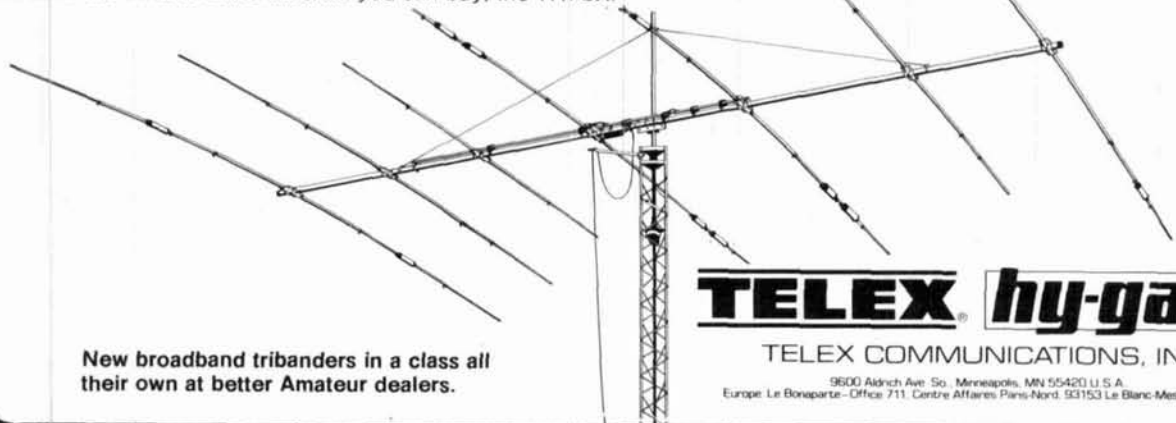

New broadband tribanders in a class all their own at better Amateur dealers.

**TELEX hy-gain**

TELEX COMMUNICATIONS, INC.

9600 Aldrich Ave. So. Minneapolis, MN 55420 U.S.A.  
Europe: Le Bonaparte - Office 711, Centre Affaires Paris-Nord, 93153 Le Blanc-Mesnil, France

## Iron Powder and Ferrite **TOROIDAL CORES**

Shielding Beads, Shielded Coil Forms  
Ferrite Rods, Pot Cores, Baluns, Etc.

Small Orders Welcome  
Free 'Tech-Data' Flyer

**AMIDON**  
*Associates* Since 1963

12033 Otsego Street, North Hollywood, Calif. 91607



In Germany: Elektronikladen, Wilhelm — Meilies Str. 88, 4930 Detmold 18, West Germany  
In Japan: Toyomura Electronics Company, Ltd., 7-9, 2-Chome Sota-Kanda, Chiyoda-Ku, Tokyo, Japan

## **PRINT THE WORLD**

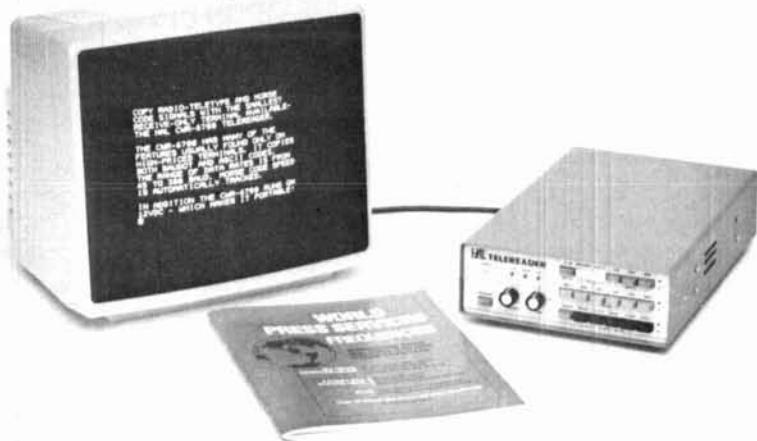

### **See What You've Been Missing!**

Stay in touch with world events, monitor weather, ship traffic, and radio amateurs. Connect to your receiver and display shortwave radio teleprinter and Morse code transmissions with the new receive-only **HAL CWR-6700 Telereader**.

- Receive ASCII or Baudot RTTY
- Six standard RTTY speeds
- 3 RTTY shifts for low or high tones
- Adjustable space for fine tuning
- Receive Morse code — 4 to 50 wpm
- 16 lines by 36 or 72 character display
- Two page video display
- Parallel ASCII printer output
- Requires +12 VDC and external TV monitor
- One year limited warranty
- Small size (8" x 3" x 12.75")

Write or call for more details. See the CWR-6700 at your favorite HAL dealer.



**HAL COMMUNICATIONS CORP.**

BOX 365  
URBANA, ILLINOIS 61801 217-367-7373

## **Radio Handbook**



by *Bill Orr*

**NEW 22nd EDITION**

The Radio Handbook has been a best seller for over 45 years. This brand-new edition covers in complete detail all of the latest state-of-the-art advances in electronics. Hams and engineers alike will find this handy, single-source reference an invaluable aid. Chock-full of projects from simple test equipment to complex receivers and amplifiers. Chapters include an explanation of Amateur Radio communications, electronic and electrical theory, tubes and semiconductor devices; a special chapter on RFI and more . . . This invaluable book is a must for every ham-shack. Orders yours today and save. 1136 pages. ©1982 □21874

\$34.95

Please add \$2.00 for shipping and handling.

*ham radio's*  
**BOOKSTORE**  
Greenville, NH 03048

# graphic azimuth and elevation calculator

A quick and accurate way to locate the geostationary satellites without a calculator

After I spent several weeks calculating the azimuth and elevation for the GOES series of weather satellites in many different locations, I decided there had to be a better way to do it than punching out the program over and over on my calculator. With a few moments of thought and an idea from a *Meteostat* (the European weather satellite) newsletter, I sat down to draw a simple graph which could be used to estimate the azimuth and elevation of ground stations for any of the geostationary satellites quickly. Since all the geostationary satellites are in the same orbits (except for their longitude), the only variable on the graph from satellite to satellite is the longitude difference between the ground station and satellite.

Many articles have been written describing the cal-

culations needed to track the low orbit satellites (such as the OSCAR series).<sup>1,2,3</sup> The most popular of these is the Oscarlocator<sup>4</sup> graphical technique. This method is popular because the clear plastic overlay lets the operator quickly estimate the satellite location without lengthy computations. Even though minicomputers are rapidly invading the ham shack, few of us have been able to implement the real-time programs which show satellite azimuth and elevation as the satellite passes overhead.

## simple geostationary calculations

All these complicated calculations are avoided with the geostationary satellite. These satellites orbit the earth 23,000 miles from the equator and make one orbit in exactly 24 hours. This keeps the satellite over a fixed spot on the earth. To the earth-bound observer the satellite appears fixed in the sky. Thus, once the antenna is fixed on the satellite no further antenna pointing is required. This is especially useful for unattended earth stations for TV and communications.

By Noel J. Petit, WBØVGI, 725 E. 51st Street, Minneapolis, Minnesota 55417

The major disadvantage of the geostationary satellite is that the tremendous distance between the earth and the satellite requires high-power transmitters and sensitive receiver systems to communicate reliably. Most satellite ground stations use parabolic dish antennas to receive the UHF and microwave signals from the satellites. Parabolic dish and other high-gain antennas have narrow beam widths, on the order of a few degrees. To estimate the width of the antenna beam use the following expression:

$$\text{width (in degrees from half power point to half power point)} = \frac{70^\circ \times \text{wavelength}}{\text{antenna diameter}}$$

Both the wavelength and antenna diameter must be in the same units. For example, both must be in centimeters. The beam width for a 2-meter diameter dish at 1691 MHz (17.74 cm wavelength) would be:

$$W = \frac{70^\circ \times 17.74 \text{ cm}}{200 \text{ cm}} = 6.2^\circ$$

This is a fairly large beam width; with such a large width, the calculation of the antenna azimuth and elevation need not be very accurate to initially find the satellite in the sky. Even a 3-meter diameter dish at 4.0 GHz (7.5 cm wavelength), where the present TV satellites transmit, has a 1.75° beam width. Knowing the azimuth and elevation within one degree is sufficient to find the satellite and then the signal-strength meter can be used to accurately align the antenna.

A graphical means of estimating the azimuth and elevation to a stationary satellite should therefore be accurate enough for most Amateur applications. Fig. 1 is such a graph. The straight vertical and horizontal lines on the chart are lines of longitude difference and latitude, respectively. The curved lines radiating from the center of the chart are lines of azimuth to the satellite in 10° increments. The curved lines concentric to the center of the chart are lines of elevation to the satellite.

### elevation, azimuth

Elevation is the angle from the horizon to the satellite. If the satellite is directly overhead, the elevation would be 90°. Elevation runs from 0° at the horizon to 90° directly overhead (the zenith in astronomical terms).

Azimuth is a bit more complex. Azimuth is the angle measured in degrees clockwise from true north. Looking north you are looking along the 0° line of azimuth. Looking east you are looking along the 90° line of azimuth and so on. From the 0° azimuth at north the measurement goes the full 360° around to north again; therefore, west is 270° azimuth, for example. All azimuth measurements to sta-

tionary satellites from the northern hemisphere will be between 90° and 270° since all the satellites lie to the south.

With the meaning of azimuth and elevation in mind, look at fig. 1. The first number you need is the ground station's latitude. Locate this latitude on the chart. For purpose of example, let us use Minneapolis at 45°N latitude. This would fall somewhere on the horizontal line half way between 40° and 50°N in the upper half of the chart.

Next, determine the longitude of the satellite and the ground station. I'll choose GOES-Central for my satellite example, at 107°W longitude. Minneapolis is located at 91°W longitude. Thus, the satellite is 16° west of the ground station. On fig. 1 find the vertical position of the -16° longitude line. If the satellite is west of the ground station use the negative side of the chart and if the satellite is east of the ground station, use the positive side of the chart.

The correct location of Minneapolis is noted on the chart with a cross (+). The elevation of the antenna can be interpolated by noting that the + is between the 40° and 30° elevation rings — a little closer to the 40° ring than the 30° ring. Thus, the elevation of the antenna should be about 36°. The + is close to the 200° azimuth line — about one-fifth of the way to the 210° line, so the azimuth of the antenna would be about 202°.

The actual calculation for the GOES-Central satellite is *elevation = 35.77°* and *azimuth = 202.06°*, from a ground station in Minneapolis. The graph

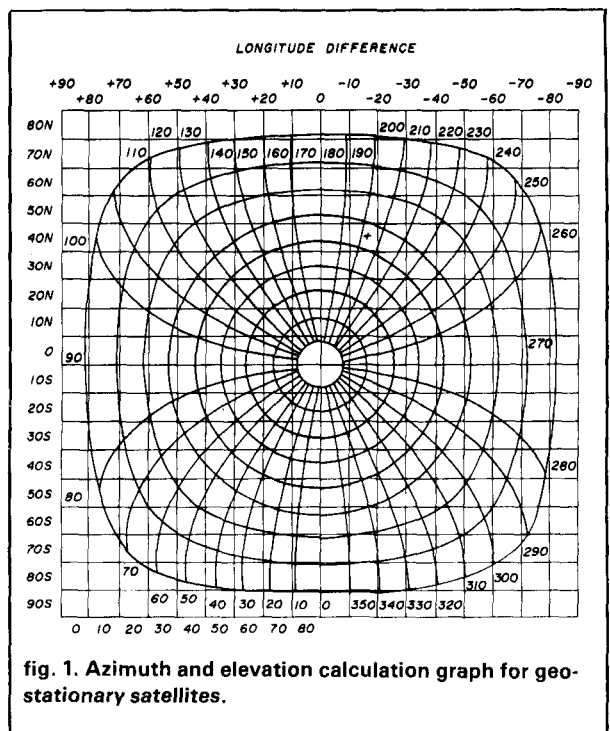

**table 1. Geostationary weather satellite status as of January 1, 1982.**

spacecraft designation	longitude	status
Meteosat	0°	operational — controlled by the European Space Agency
GOES-5	75°W	operational — GOES-East
GOES-2	107°W	operational — GOES-Central
GOES-1	127°W	standby
GOES-3	130°W	standby
SMS-1	131°W	standby
GOES-4	135°W	operational — GOES-West
GMS	140°E	operational — controlled by the Japan Space Agency

technique is accurate enough to use for most small antennas, but its big advantage is that there is little chance of making an error in calculation with this method.

A fairly complete list of the geostationary satellites can be found in a recent issue of *ham radio*.<sup>5</sup> However, the GOES-series of satellites is not accurately presented. Three GOES satellites are operational at any time. There may be any number of standby satellites in orbit in case the operational satellites experience a failure. Each satellite has two names (much like the naming system chosen for the OSCAR satellites). One name (like GOES-2 or SMS-2) designates the piece of hardware from the development stage to the time it was put in orbit. The other name designates the satellite when it is in use in space. **Table 1** lists the present status of the geostationary weather satellites in orbit as of January 1, 1982. This list includes the Japanese and European satellites which function much like the GOES satellites.

With this simple chart you can easily find the stationary satellites in the sky and tune in on the world of space communications.

### references

1. C.F. Milazzo, KP4MD, "Satellite Tracking Equations for Texas Instruments Calculators," *ham radio*, June, 1978, page 68.
2. R.A. Cleis, WB6POU, "Low-Cost Satellite Tracking Computer," *ham radio*, March, 1980, page 12.
3. P.C. Bunnell, WA6VJR, "Tracking Satellites in Elliptical Orbits," *ham radio*, March, 1981, page 46.
4. C.L. Harris, WB2CHO and J.P. Kleinman, "The Oscarlocator," *QST*, November, 1976, page 51.
5. W.E. Pfister, Jr., W2TQK, "Locating Geostationary Satellites," *ham radio*, October, 1981, page 66.

ham radio



## KIT #1

DOWNCONVERTER ..... \$19.95  
 VARIABLE POWER SUPPLY ..... \$19.95  
 CIGAR ANTENNA ..... \$19.95  
 ★ Kit Special — buy all three..... \$49.95  
**SAVE \$10.00**

## KIT #2

DOWNCONVERTER ..... \$19.95  
 VARIABLE POWER SUPPLY ..... \$19.95  
 KD 44 DISH ANTENNA..... \$47.95  
 ★ Kit Special — buy all three..... \$79.95  
**SAVE \$7.90**

## ASSEMBLED SPECIAL

ASSEMBLED DOWNCONVERTER .... \$39.95  
 ASSEMBLED VARIABLE  
 POWER SUPPLY..... \$29.95  
 CIGAR ANTENNA ..... \$19.95  
 ★ Assembled Special —  
 buy all three..... \$79.95  
**SAVE \$10.00**

## Great Gift Ideas for the Holiday Season

SUPERVERTER I assembled only .... \$109.95  
 crystal not included  
 SELECTIVE PREAMPLIFIER..... \$26.95  
 HIGH GAIN TRANSISTOR..... \$6.95  
 DRIFT MODIFICATION ..... \$1.25  
 KD44 DISH ANTENNA ..... \$47.95

1691 Downconverter, built  
 & tested only . . . call for price

For information or ordering  
 (817) 860-1641

Hours, 8:30-5:00 CST; Mon.-Fri.

# UNIVERSAL COMMUNICATIONS

P.O. Box 339  
 Arlington, TX 76004-0339



# an interview with Dr. Kenneth Davies

Dr. Davies of NOAA discusses magneto-ionic effects and their relevance to radio propagation



Dr. Kenneth Davies, one of the leading experts in the field of magneto-ionic studies, has provided guidance in that field since 1949. At present, in his capacity as chief of the Research Division of the Space Environment Laboratory of NOAA, he supervises a technical staff involved in solar-terrestrial (interplanetary, magnetospheric, ionospheric, and atmospheric) studies.

During the past thirty-three years Dr. Davies has worked on projects investigating high-latitude ionospheric absorption and the use of oblique-incidence, pulsed ionosondes. At the famous CRPL (Central Radio Propagation Laboratory), he pioneered the high-frequency Doppler technique used for studying transient ionospheric phenomena. In addition, he was the principal investigator of the NASA/NOAA ATS-6 radio beacon project, which involved placing a frequency-, amplitude-, and polarization-stable transmitter on a geostationary satellite. The ATS-6 space platform provided continuous measurements of the electron content of the ionosphere.

Dr. Davies, author or co-author of over one hundred publications, is perhaps best known for his book *Ionospheric Radio Propagation*, which has become a standard reference in the field. While his professional credentials are very impressive, they are surpassed by his congeniality, his concern, and his ability to explain complex phenomena in terms a layman can understand. He is truly a scientist of highest magnitude.

*ham radio* magazine is pleased to introduce the first in a series of technical interviews with experts in various fields of communications. In this issue we are presenting excerpts from a two-hour interview with Dr. Kenneth Davies of the National Oceanic and Atmospheric Administration in Boulder, Colorado. Dr. Davies answers questions regarding radio phenomena that affect all Radio Amateurs.

This series will continue, in later issues, with discussions with experts in other related fields of direct interest to hams. The comments of our readers are welcomed.

**ham radio:** I understand that your chief interest lies in magneto-ionic studies. What is that?

**Dr. Davies:** Magneto-ionic studies deal with the propagation of electro-magnetic waves, more specifically, radio waves in a plasma (ionized medium) under the influence of an external magnetic field, the magnetic field of the earth. When a radio wave enters the ionosphere it splits into two waves, an ordinary wave (O) and an extraordinary wave (X). The waves are reflected at different heights, travel with different speeds, and, most importantly, are absorbed differently. Generally, the extraordinary wave is absorbed more than the ordinary wave, especially near what is known as the gyrofrequency. (See glossary.)

**hr:** How does a radio wave leaving an antenna know whether it's going to end up as an O or X wave?

**Davies:** Basically, it doesn't know until it gets to the ionosphere. When a radio wave enters the ionosphere it moves the electrons there. The electrons bob up and down in reaction to the electric vector of the wave — very much like a cork in water when a wave passes by. They start oscillating. In the presence of a magnetic field they *can't* oscillate back and forth linearly. The electron motion is twisted by the

By Rich Rosen, K2RR, technical editor, *ham radio* magazine

action of the earth's magnetic field. On average, half the electrons rotate one way and half the other. The energy is divided roughly 50/50, but not always. There are certain circumstances in which the wave can become all X or O or you can intentionally polarize the wave to achieve this.

Suppose you were at the geomagnetic equator. If you pointed your antenna in a north-south direction all the energy would go into exciting the O wave because the electric vector is parallel to the magnetic field vector. If you try to move an electron along a magnetic field at that location it behaves as if there were no field. (*Ed Note:  $\vec{F} = q\vec{v} \times \vec{B}$  where  $\vec{F}$  = force on electron, zero in this case,  $q$  = charge,  $\vec{v}$  = velocity vector and  $\vec{B}$  = magnetic field vector -- the cross product of two in-line vectors = 0).*)

Now, at or near the gyrofrequency (approximately 1.5 MHz), the extraordinary wave is very heavily damped. If you use a vertical radiator at installations near the equator with East-West and West-East propagation you will excite the X wave. (*Ed Note: This is of particular importance to South American, African, and other 0° latitude hams operating on 160 meters.*)

**hr:** It's important in Amateur Radio for example because a number of hams who are very interested in DXing use both horizontally and vertically polarized antenna systems.

**Davies:** That is what magneto-ionic theory is all about. Understanding fading is important if one is to understand radio wave behavior. The fact that signals fluctuate can be related to O and X ionospheric theory. The O and X waves travel by slightly different paths which change as the sun rises and sets. When the two waves beat, deep fading occurs (as at sunrise).

Fading can also result from wave reflection from different ionospheric layers, and sometimes even different reflections from the same layer. This can be explained in terms of layer movement producing phase differences (including 180 degrees) between components of the same wave.

### **satellite communications is affected by propagation phenomena**

**Davies:** Trans-ionospheric propagation (propagation through the ionosphere as occurs in satellite to ground communications) provides another example of O and X wave phenomena. A linearly polarized wave emitted from a satellite is decomposed into O and X waves that travel at slightly different velocities and increasing phase separation. The combined wave of constructively interfered components is equivalent to a rotating electric vector (changing polarization). The ionosphere changes both daily and seasonally, and the signal polarization with it. During

the morning, for example, the electric vector may rotate in one direction and during the afternoon in the other. Over a long period of time conservation must occur; the net rotation must be zero.

**hr:** It sounds like the length of the rotation period might be related to some very basic phenomena.

**Davies:** Yes. If conditions on the sun and in the earth's atmosphere were stable then the polarization change — say from 00 hours one night to 00 hours the next — would not exist. In practice, that doesn't happen. The reason for this is partly that the sun varies from day to day, and therefore conditions are different, and also that the atmosphere is different: The upper atmosphere is very much like the lower atmosphere; there are winds up there. There are irregularities. These winds vary and affect the electron density.

**hr:** Are we talking about a completely random process?

**Davies:** You know that's our tendency. People have a tendency to say that if you can't explain something it's random. The answer is that this looks random until you understand what is causing it. These conditions are not random in the sense that they fluctuate for a reason. The reason is that the sun varies. As ionized particles from the sun approach the earth they set up electric fields from dawn to dusk across what's called the magnetosphere, the outer region of the earth's atmosphere. This active field in turn affects the plasma in the ionosphere. So a varying sun causes, through several intermediate steps, ionospheric variations. If we knew more about the detailed physics of the sun, this process might no longer be considered "random."

**hr:** I differentiate between a process that is completely random and one that appears to be random but is really not — or is everything causal? That is, we just don't know the cause?

**Davies:** This is my point. I would say that everything that happens in the ionosphere, as far as we know, happens for a definable reason.

**hr:** I'm thinking of the fact that you can build what's called a random-number generator. That is truly random. Or is that causal as well?

**Davies:** One source of random signals produced electrically is just a hot wire: the random motion of electrons in a resistor. But again it's random in the sense that there are a very large number of them, all of them moving in different directions. We cannot specify what any one electron is doing. You can specify the aggregate changes but you can't specify one.

### **solar activity indicators**

**hr:** What are the best indicators of solar activity? I

understand that ultraviolet, as a measurement technique, is preferred over the 10.7-cm flux readings (see glossary).

**Davies:** An indicator of solar activity is the sunspot number. Sunspots, darker and cooler areas on the sun, were discovered by Galileo about 1610, and measurements of them have been made more or less continuously since the early 18th century, about 1715. These numbers show distinct cycles, the most prominent of which is the eleven-year cycle. There are longer cycles and there are shorter variations. For example a shorter variation of twenty-seven days is related to the rotation of the sun, as seen from the earth.

What we call the sunspot number is determined by a simple formula that gives a lot of weight to groups of sunspots:

$$R = K(10g + s)$$

where  $R$  = sunspot number

$K$  = correction factor

$g$  = number of groups of sunspots

$s$  = number of individual sunspots

The question is, How good an index is this? Obviously, two different observers might see different groups on the sun. One observer might say that two groups exist — another observer that it's only one big group. Consequently any individual value of sunspot number is subjective. But if you have a sufficient number of observers over a long enough period of time, then you obtain an index which is at least roughly independent of individual preference; that is, the various biases cancel out.

**hr:** Why 10X (weighting) for a group (of sunspots)?

**Davies:** I don't know the exact historical reason for this, but it has to depend on a belief by solar astronomers (not ionospheric) that groups are more important than individual spots. It has been found that the critical frequencies of the ionospheric layers vary roughly linearly with sunspot number. This is important since sunspot numbers enabled people, in the early days, to project into the future. They could see a long series of cycles and predict what the next one was going to be.

Systems have been developed for predicting future sunspot cycles. One of these developed at CRPL is the McNish-Lincoln method. Data from an ascending cycle enables you to predict, fairly reasonably, sunspots for the next year or so.

**hr:** Could they have predicted cycle 21's demise based on its rise?

**Davies:** I'm not sure how long they took to predict the peak, but the prediction was very good for this

cycle once it started. Now there are departures. You know this was a steep cycle. And there are differences, perhaps ten or twenty units. However, in general there is close correspondence between the predicted and measured curves.

**hr:** Cycle 21 (present cycle) had a twelve-month maximum moving average of a little over 160. A very nice cycle. And this one, what a beauty (looking at cycle 19) with 201 smoothed sunspot numbers.

**Davies:** That's the grand-daddy of them all.

**hr:** It was an interesting time to be an active Radio Amateur.

**Davies:** That's right, 1958. (Cycle 19 was the largest modern recorded sunspot cycle, peaking late '57, early '58.)

**hr:** What about ultraviolet as a measurement tool?

**Davies:** Let's go back to sunspots for a moment. Why should sunspots be related to anything in the ionosphere? They are just black patches on the sun. To answer the question, let's look at how the ionosphere is formed. The F-region of the ionosphere is caused mostly by solar radiation in the region of 300 to 1200 Å (Angstrom unit =  $10^{-10}$  meters). The EUV (Extreme Ultra-Violet) of the sun's radiation ionizes the oxygen in the upper atmosphere. But you can't measure that from the ground, since it's all absorbed in the ionosphere. If you look at these radiations from satellites above the ionosphere, you find that there's a high correlation between them.

**hr:** Which satellites? You mean satellites in geostationary orbit?

**Davies:** Orbiting satellites appreciably above the maximum of the F-layer.

X-rays, on the other hand, having wavelengths of roughly 1-10 Å, come through the F-region. They have much more penetrating power and ionize the D and E-regions. An important point (hams take note!) is that over a sunspot cycle the EUV can increase by a factor of perhaps ten from low to high sunspot number, whereas the X-ray flux may increase by a hundred or a thousandfold during that same period.

**hr:** No wonder my 3.8-MHz signals get so absorbed during the sunspot cycle peak.

**Davies:** There's a much bigger solar factor variation of X-rays than there is of EUV. As you go further into the longwave part of the spectrum this becomes even more noticeable. For example, in the visible part of the spectrum there's hardly any change. The solar constant, the amount of energy falling on one square meter, doesn't change very much, less than approximately ½ to 1 percent.



Solar flares are another important category of emissions from the sun that affect terrestrial conditions. They are shorter-term fluctuations lasting from several minutes to days. A sudden ionospheric disturbance, a direct effect of X-rays from flares, can cause a radio blackout. The D-region experiences a tenfold increase in ionization. The D-region is important because, even though there are fewer electrons there than in the F-region, there are many collisions with neutral molecules. Remember that when a radio wave enters the ionosphere, the electric vector sets electrons in motion and, normally, if there were no collisions that energy would be restored, since a moving electron radiates. However, if the electron hits a molecule the energy that's re-radiated is basically converted into heat (from the motion) and radio noise; that is, random, electro-magnetic noise is generated. Once a collision takes place, the electron loses energy, and in the D-region these collisions occur often. This is the region where the energy is absorbed from the radio wave.

**hr:** What about the 10.7-cm flux?

**Davies:** The 10.7-cm flux technique is a good measurement. It has several advantages. First, unlike the sunspot number, it is a measurable quantity. Secondly, it penetrates the earth's atmosphere and can be measured on the ground. You don't have to see the sun. On a cloudy day it can still be measured.

**hr:** How accurately can you measure this?

**Davies:** It can be measured to roughly 0.1 percent.

**hr:** One thing still confuses me. It's possible in approaching cycle 21 minimum to have an SSN (twelve-month moving average) of 20 or 30 or less and yet on any particular day to have a high solar flux indication. Which should a communicator follow more closely, the SSN or flux measurements?

**Davies:** I would think that the 10.7-cm flux is probably the best index because of the reasons I've already given.

**hr:** Is it possible to have a fairly heavily ionized ionosphere even during a time of solar minimum?

**Davies:** Yes it is. Even at a sunspot minimum, severe magnetic and ionospheric storms can occur. In speaking of storms, by the way, these are disturbances produced by particles impinging on the earth that affect electrons stored around the earth. When a disturbance occurs in the solar wind, these particles accumulate near the earth, accelerate, and plunge into the earth's atmosphere. They are stored in the magnetosphere, the Van Allen radiation belt. These storms are very important from a radio communications point of view because they are the most destructive of all the ionospheric effects. They can last

for two or three days and cause the critical frequencies (maximum frequencies) to drop by a factor of two or three, which means the spectrum available to communicators is reduced. This is particularly noticeable in high latitudes, near the auroral zone, because that's where the particles are.

**hr:** Does it enhance PCA (polar cap absorption)?

**Davies:** Yes, generally, but not always. Polar cap absorption events are due to energetic protons over the polar caps — but *inside* the auroral ring. Whereas storms *start* in the auroral zones. Storms are much more important than PCAs.

PCAs are relatively rare. You get a few per solar cycle and they're confined to high latitudes where the density of population is low. Some people mistakenly label an ionospheric storm as a PCA when they really mean ionospheric storms. Ionospheric storms are due to the arrival of particles of lower energy; not millions of electron volts, but a few thousand EV.

In a severe ionospheric storm energy is dumped into the auroral zone but the effects are carried by atmospheric circulation to low and middle latitudes where they can play havoc with radio communications by depressing the upper frequencies.

**hr:** I saw a report of a storm's effects lasting up to fourteen days.

**Davies:** That's right, especially in the lower ionosphere. It's called the storm after-effect and disturbs very-low-frequency navigation systems like Omega. Although the storm has died away as far as magnetic disturbances are concerned, the storms after-effects persist in the ionosphere.

## cycle 21 characteristics

**hr:** We have talked briefly about cycle 21. Is it more or less typical, or has it surprised people?

**Davies:** It's taken many people by surprise. And the reason is this: Although it's a relatively big cycle with respect to ionization, so far as disturbances and storms are concerned it's relatively modest. It's not what we would have expected. Until this year, when we have had some disturbances, the number of storm effects have been small given the size of the cycle. The reason we're surprised, of course, is really that we don't know much about the solar cycle; that is, our sample of previous solar cycles is relatively limited. That is why we need to continue observations of the sun and related geophysical effects.

**hr:** Where are we in the cycle right now?

**Davies:** We're about halfway down the declining part of the cycle.

**hr:** What would our smoothed sunspot twelve-

month moving average be?

**Davies:** The latest sunspot number for June, 1982, was 110.

**hr:** That's still very high.

**Davies:** But then the month before it was down to 81. Whereas the month before that it was up to 122. Yes it is high.

**hr:** For January, 1983, for example, which is when this information will be published, what do you estimate?

**Davies:** In January we can probably expect numbers of the order of 90.

**hr:** Do most cycles go down to 5 or 10 (SSN) regardless of their maxima? Cycle 19, for example?

**Davies:** Yes roughly. They go down to about 10, some go to 5. Big cycles can be followed by small minima. Cycle 18, which began in 1944, was a big cycle with a very low minimum.

**hr:** How do people predict future cycles based on past cycles?

**Davies:** There are a number of ways. One way is to take a time series analysis of previous cycles, reducing it into simpler terms or waves with different periods. Then predict the future by getting equations for each of these waves. This is a purely mathematical approach.

**hr:** An orthogonal series like a Taylor or Fourier?

**Davies:** Fourier usually, or a new method, developed in the NOAA laboratory by Dr. Paul, called anharmonic frequency analysis. It provided a very good estimate for cycle 21. But, depending on what prediction method you use, you can come up with very different cycles.

**hr:** If, to predict cycle 21, you were to take all the previous cycles up to 21 and then do your Fourier or anharmonic frequency analysis, what would be the results?

**Davies:** It turned out that the maximum sunspot numbers predicted by that technique did, in fact, prove to be around 160 (cycle 21).

We're still a long way from an understanding of the sun, which is what we need to be able to predict. You must remember that all these methods tend to be recipes, not true understanding.

**hr:** Will we ever be able to accurately predict cycles? Let's look into the future. Is there any reason to believe that we will understand all the processes both quantitatively and qualitatively well enough to be able to say, "Cycle 475 is going to have a peak of . . . "?

**Davies:** Yes, I think that is possible in principle. After all, think of astronomy and how we can predict satellite and planetary orbits with extremely good accuracy. There's reason to hope that, given enough effort, the secret will be unlocked. At the moment we don't know if we're doing the right thing. We have to wait for a Newton . . .

### extraplanetary effects on earth

**hr:** We talked about sudden ionospheric disturbances. Are there other causatives, such as planetary conjunctions?

**Davies:** Yes, I think it was Mr. Nelson of RCA who hit upon a method by which he predicted disturbances on the basis of planetary alignment. He said that when the planets were lined up on one side of the sun storms would occur. The interesting thing is this: it seems that he predicted a few of these storms within a number of days. But statistically, these methods do not stand up to scrutiny. The question I have asked people who criticize this is the following: If you could predict the big ones, isn't that important — much more important than missing out on the small ones?

### less well known ionospheric layers

**hr:** Are there layers other than D, E, and F?

**Davies:** There have been some claims for a C-layer which is formed about 60 km up, caused by cosmic rays and is therefore always present. There is another phenomenon seen on ionograms during a storm when the critical frequency of a regular F<sub>2</sub> is greatly diminished: a little kink appears very high up and is called a G-layer. It's probably not a distinct layer but is a phenomenon that occurs, let's say, at special times only.

**hr:** Would it correspond to the normal height of the F-layer? Or is it even higher?

**Davies:** It's difficult to say how high it is because on an ionogram some of the apparent height is caused by retardation underneath. It's not a true height of reflection. The height is actually lower than the height you see on the ionogram.

**hr:** We're talking virtual heights on an ionogram?

**Davies:** Yes, virtual heights. During solar eclipses, in certain parts of the world, the F<sub>1</sub>-layer tends to break up into F<sub>1</sub> and F<sub>1½</sub>. Then the E-layer at times has little kinks in it called the E<sub>1</sub>-layer and the E<sub>2</sub>-layer. But you must remember that these are not necessarily physical phenomena. They are the appearances of traces on the ionogram.

**hr:** Are new techniques and instruments now available that will help us differentiate between an apparent and an actual height?

**Davies:** The new digital ionosondes (conventional sounders are analog) will help us interpret the results. What they will tell us is where the signals actually come from: whether they arrive from vertically above the sounder or off to one side. What the new sounders will therefore do is help us interpret the structure of the ionosphere. That will help.

We've found that some of these "extra" layers are not extra layers. They are layers off to one side at the same height — perhaps parts of another layer. (As an example, if you're 45 degrees off vertical and get a reflection from a hundred kilometers away, you might see another trace at 140 km. Without any other information it's possible to interpret that as a layer at 140 km.)

A great deal of effort in the 1940s and 50s was put into interpreting echo traces on ionograms. Without full knowledge, it's a very frustrating exercise and in many cases fruitless.

A technique that gives the true height of the ionospheric layer directly is the incoherent scatter technique, in which radio power is scattered by individual electrons. This requires very large and expensive systems, and there are only about six of them in operation.

### **modes of propagation**

**hr:** Most Radio Amateurs are familiar with the terms one-hop, two-hop via the E or F-layer, but what about M-type:  $F_2 - E_S - F_2$  and some of the lesser known modes?

**Davies:** Well, for example, in trans-equatorial propagation, there's evidence that you can get, because of distortion of the ionosphere, an equatorial anomaly. You can get two reflections off the ionosphere without an intermediate ground reflection. It happens in the evening hours around the equator. There are relatively few of these mechanisms of propagation that are really well documented and well founded.

There have been suggestions that transequatorial propagation is really due to ducting — ducts which go way out, well above the ionosphere, and trap energy.

**hr:** Well above the ionosphere?

**Davies:** Yes, or into the upper parts of the ionosphere.

**hr:** When you say well above, what are you referring to? 500 km?

**Davies:** Maybe 500, 1000, or 2000 km. But it's not as

great as Whistler waves, which are VLF waves, audio-frequency-type waves, which can go out to very large distances, like 30,000 km.

### **long delayed echoes**

**hr:** It is said that there's a phenomenon called LDE (long-delayed-echo), approaching a second. Do you know of any reason for an LDE that long?

**Davies:** It's not a field I've closely followed. Plasma physicists say that there is some instability — a storage in the plasma — that takes a long time to release. The people who have studied it insist that these echoes are real. They have coded the signals and claim that they have received real long-delayed returns.

### **Maunder minimum**

**hr:** Is there evidence today to indicate that the Maunder minimum actually did occur, or is it felt that it was merely a result of lack of recording capability?

**Davies:** I think that there is evidence that there was a Maunder minimum. It's not likely to have been simply a lack of data.

**hr:** Is it probable that future generations will see a Maunder minimum?

**Davies:** I would say yes. It's certainly quite possible. It could happen many times in fact. It could happen the next cycle. Who knows what the next cycle is going to be?

### **sidescatter**

**hr:** Can you explain the reason for signals sometimes deviating from great circle paths? One example that I recall is the U.S./Europe path via North Africa. Is this a well-known, often-occurring condition?

**Davies:** Yes, I think it is. It's been known for many years that signals from Europe often appear to come from directions roughly in the mid Atlantic or North Africa, the Sahara region. One suggestion has been made that this occurs when the direct path say from Europe to North America passes through a disturbed auroral zone. If that zone is disturbed, the direct path through the auroral zone is cut out. But you still receive a signal across the Atlantic. It is reflected off the coast of Africa; that is, it hops down to Africa, scatters there, and then across the Atlantic. That bent path is too far south for the storm to affect it. That has been documented and is a possible explanation.

**hr:** Are there other explanations for sidescatter?

**Davies:** I think that's the primary one. The other possibility for a signal coming off the great circle path

is ionospheric irregularities, particularly field-aligned ones. Irregularities in the ionosphere tend to be field-aligned because electrons can move easily along the field but not across it, creating sheets or columns of ionization. If the geometry is right you get perpendicular reflection.

### twilight-zone propagation

**hr:** What is twilight zone (gray-line) propagation? It's a term Radio Amateurs use to explain a non-great-circle path that provides an unexpected opening.

**Davies:** I know that people claim RTW echoes are signals received long distances along the twilight zone, or earth's day/night dividing line. It seems to be some form of ducting.

### forecasting and predicting

**hr:** Can you explain the difference between the terms forecasting and predicting?

**Davies:** Yes. When people talk about predicting, they mean long-term: predicting what the critical frequencies will be next year or the year after or during the next sunspot cycle. This is done for long-range planning purposes: what frequencies you should request, what antenna should you design, angles of takeoff, arrival, and so on. Propagation conditions for the long term are usually referred to as predictions.

Forecasting on the other hand is usually thought as short term, in terms of solar flares.

### forecasting solar flares

**Davies:** To forecast solar flares, we must keep a watch on the sun all around the world and report what happens when a solar flare has occurred by optically viewing the shape and features of the sun. These are solar features such as plages, magnetic configurations, etc. We measure the way the solar magnetic fields become distorted. It's an energy build-up at these active regions of the sun. When this occurs we also receive other information from the sun, solar radio emissions for example. One way of forecasting a PCA is by observing the shape of the spectrum, the so-called U-spectrum wherein the flux has a U (or dip) in the microwave region. There's a minimum in the spectral distribution.

**HR:** Just prior to the disturbance?

**Davies:** Yes. We look at the sun in visible light and X-rays. X-rays are very important. X-rays are classified C(s), M(s), and X(s), in which an X flare is a large flare which causes short-wave fadeout (the system was developed in the Space Environmental Services Center). This is one of the best ways we now have of measuring the size of a flare and its ionospheric effects. It's possible to have a big flare optically that may have almost no effect on the earth.

**hr:** Is this because it misses the earth?

**Davies:** No. It may be because the spectral content is different. Remember you can have two large flares: one has strong X-ray burst components that ionize the D-region and cause blackout; the other flare, which looks the same in visible light, may not have the X-ray components.

Also, the other point you've raised is valid. The earth must be in the proper position to be hit by the particle burst. We don't know at the moment what the relationship is between the visible appearance of a flare and its particle output. That is something that we must determine.

### future of forecasting

**hr:** Let's look ahead twenty years. Do you see a considerable improvement, based on the work that is occurring right now in the lab, in terms of forecasting?

**Davies:** Well, unfortunately no. The outlook is very bleak I must admit. Under the President's budget all research, for example, in this lab, Space Environmental Research, will be abolished.

### tools of the trade

**hr:** Can you briefly describe the function of the following instruments: auroral radar, Faraday polarimeter, digital ionosonde?

**Davies:** An auroral radar is a fixed-frequency radar which bounces signals off ionization in the auroral zone.

A Faraday polarimeter is a device that measures the rotation of the electric vector of a wave and, hence, the electron content of the ionosphere.

A digital ionosonde is a recording instrument that provides standard amplitude and height information (as in conventional ionosondes) and parameters that can be used to determine polarization, phase, and direction of arrival of the signals.

**hr:** Can't these ionosonde tasks be accomplished using conventional instrumentation?

**Davies:** Yes, separately. The new digital sounders enable all of these to be done together. That's the big advantage of the new system.

The major thing that we are able to do with new information is determine where the signals come from — and therefore what the horizontal gradients in the ionosphere are. The ionosphere is neither a flat nor a concentric medium.

For example, there's a mid-latitude trough (depression in electron density) in the F-region just below the auroral zone. It's very important, since it distorts the ray path of over-the-horizon radars.

### interest in hf

**hr:** This naturally brings us to my next question. Why is there renewed interest in hf?

**Davies:** It's related to the obvious advantages of hf. The installations cost less and the system is useful for long distances. There was a feeling in the 60s, when geostationary satellites were beginning to be used, that our radio communications problems had been solved. We thought we could get rid of ionospheric effects by going to satellite communications — the ionosphere would have no effect. But the ionosphere does have an effect, even at these frequencies, in the form of scintillation; even up to 6 GHz. Also, of course, from a vulnerability point of view, satellites are perhaps more vulnerable than the ionosphere to an enemy action. You can wipe out a satellite, but it's more difficult to wipe out the ionosphere.

**hr:** You mentioned that the ionosphere is extremely forgiving.

**Davies:** Yes, I think this is true of the entire earth. It recovers from abuse. We pollute the ionosphere intentionally and unintentionally. Huge electron depletions have been noted during the launches of Saturn rockets for example. Thousands of kilometers are affected.

**hr:** Temporarily?

**Davies:** Yes, perhaps for an hour or two at night. The sun replenishes it. Even though huge quantities of O<sub>2</sub>, H<sub>2</sub>, and water are put into the atmosphere, these are natural constituents. They don't do long-term damage.

### future of hf

**hr:** What's the future for the high frequencies?

**Davies:** I think they will always be with us. I can remember when I started my professional career, people said to me the high frequencies are dead. That was thirty years ago.

### glossary

**10.7-centimeter flux** — Solar radio noise flux at 2800 MHz that is indicative of the degree of E-layer ionization.

**Maunder minimum** — A name applied to a period of approximately 70 years in the late seventeenth and early eighteenth centuries, during which solar activity is believed to have been unusually low.

**Gyrofrequency** — Gyrofrequency, also called the gyromagnetic frequency, is a frequency derived by the formula below that describes the motion of an electron in a magnetic field. In the ionosphere, where the magnetic field intensity is roughly 0.5 gauss, the gyrofrequency is approximately 1.5 MHz.

$$f_H = \frac{1}{2\pi} e/m B$$

where  $f_H$  = gyrofrequency  
 $e$  = the charge on an electron  
 $m$  = the mass of an electron  
 $B$  = magnetic field intensity

ham radio

State  
of the art



by

K.V.G.

### 9 MHz CRYSTAL FILTERS

MODEL	Application	Bandwidth	Poles	Price
XF-9A	SSB	2.4 kHz	5	\$50.60
XF-9B	SSB	2.4 kHz	8	68.60
XF-9B-01	LSB	2.4 kHz	8	91.35
XF-9B-02	USB	2.4 kHz	8	91.35
XF-9B-10	SSB	2.4 kHz	10	119.65
XF-9C	AM	3.75 kHz	8	73.70
XF-9D	AM	5.0 kHz	8	73.70
XF-9E	FM	12.0 kHz	8	73.70
XF-9M	CW	500 Hz	4	51.55
XF-9NB	CW	500 Hz	8	91.35
XF-9P	CW	250 Hz	8	124.95
XF910	IF noise	15 kHz	2	16.35

### 10.7 MHz CRYSTAL FILTERS

XF107-A	NBFM	12 kHz	8	\$64.10
XF107-B	NBFM	15 kHz	8	64.10
XF107-C	WBFM	30 kHz	8	64.10
XF107-D	WBFM	36 kHz	8	64.10
XF107-E	Pix/Data	40 kHz	8	64.10
XM107-SO4	FM	14 kHz	4	28.70

Export Inquiries Invited.

Shipping \$3.50

### MICROWAVE MODULES VHF & UHF EQUIPMENTS

Use your existing HF or 2M rig on other VHF or UHF bands.

### LOW NOISE RECEIVE CONVERTERS

1691 MHz	MMk1691-137	\$224.95
1296 MHz	MMk1296-144	119.95
432/435	MMc435-28(S)	69.95
439-ATV	MMc439-Ch x	74.95
220 MHz	MMc220-28	69.95
144 MHz	MMc144-28	54.95

Options: Low NF (2.0 dB max., 1.25 dB max.), other bands & IF's available

### LINEAR TRANSVERTERS

1296 MHz	1.3 W output, 2M in	MM1296-144	\$374.95
432/435	10 W output, 10M in	MM1435-28(S)	299.95
144 MHz	10 W output, 10M in	MM1144-28	199.95

Other bands & IFs available.

### LINEAR POWER AMPLIFIERS

1296 MHz	10 W output	MML1296-10-L	\$ ask
432/435	100 W output	MML432-100	444.95
	50 W output	MML432-50-S	239.95
	30 W output	MML432-30-LS	ask
144 MHz	100 W output	MML144-100-S	264.95
	50 W output	MML144-50-S	239.95
	30 W output	MML144-30-LS	124.95
	25 W output	MML144-25	114.95

All models include VOX T/R switching.  
 "L" models 1 or 3W drive, others 10W drive.

Shipping: FOB Concord, Mass.

### ANTENNAS



#### 420-450 MHz MULTIBEAMS

48 Element	70/MBM48 15.7 dBd	\$75.75
88 Element	70/MBM88 18.5 dBd	105.50

#### 144-148 MHz J-SLOTS

8 over 8 Hor. pol	D8/2M 12.3 dBd	\$63.40
8 by 8 Vert. pol	D8/2M-vert 12.3 dBd	76.95
8 + 8 Twist	8XY/2M 9.5 dBd	62.40

#### UHF LOOP YAGIS

1250-1350 MHz 28 loops	1296-LY 20 dB	\$49.75
1650-1750 MHz 28 loops	1691-LY 20 dB	55.95

Order Loop-Yagi connector extra:

Type N \$14.95, SMA \$5.95

Send 40¢ (2 stamps) for full details of all your VHF & UHF equipment and KVG crystal product requirements



si

(617) 263-2145

SPECTRUM  
INTERNATIONAL, INC.

Post Office Box 1084  
Concord, MA 01742, U.S.A.

# remote-site receivers and repeater operation

## A system for selecting the strongest signal from remote-site receivers

**Repeaters are usually built** for mobile and hand-held use. Usually the repeater transmitter has a 20 dB power advantage over a hand-held. At the same time, the received signal at the repeater is reduced by this same figure. This means we can hear the repeater transmitter much better than the repeater receiver hears the hand-held.

One of the easiest ways to equalize coverage is to install remote receivers (commonly referred to as satellites). This concept has been used successfully for many years on commercial fm systems, providing full quieting signals over an entire metropolitan area.

### satellite operations

A remote receiver system places receivers in locations distant from the main repeater transmitter site. The remote receivers relay the weaker signals back to the transmitter via UHF links. The ideal system, shown in **fig. 1**, uses three remote receivers feeding one transmitter. Since the receivers are located away from the transmitter, you can run higher transmit output power without desense.

So far this seems fairly simple; however, the big problem is designing an effective voting system where the transmitter site will vote (select) the strongest, fullest quieting signal. In commercial systems voting becomes very elaborate, almost impos-

sible for Amateur repeater groups to maintain and afford. Motorola uses a system of encoding tones at various levels in which an elaborate gate system selects the receiver hearing the best signal.

Many Amateur repeater groups could use multiple receiver site systems, however, to date there has not been much in the way of a simple and inexpensive voting system described in Amateur literature. This article describes a very simple voting system that will allow three remote receivers to feed one transmitter with the best quieting signal. It has served our Marissa, Illinois, repeater system very well.

The transmitter site contains three link-receiver boards which operate on the 220 MHz band. These boards were removed from Midland Model 13-509 220 MHz transceivers while the corresponding transmitters were used at the three receiver sites. At WD9GOE each of the 220 MHz receiver boards were mounted on a separate chassis with proper connectors to plug in to a main frame. This allows for easy installation and quick service should malfunctions occur. All three receivers are exactly alike except for the operating frequency. Each 220 MHz transmitter operates on separate frequencies. WD9GOE/R uses 30 kHz separation between the three link frequencies.

### voting secret is time

The secret to this simple voting system relies on the time it takes the 2-meter receiver to turn on the link transmitter. A full quieting signal turns the link on immediately. A signal that is -10 dB quieting or

**By Bob Heil, K9EID, #2 Heil Industrial Blvd.,  
Marissa, Illinois 62257**

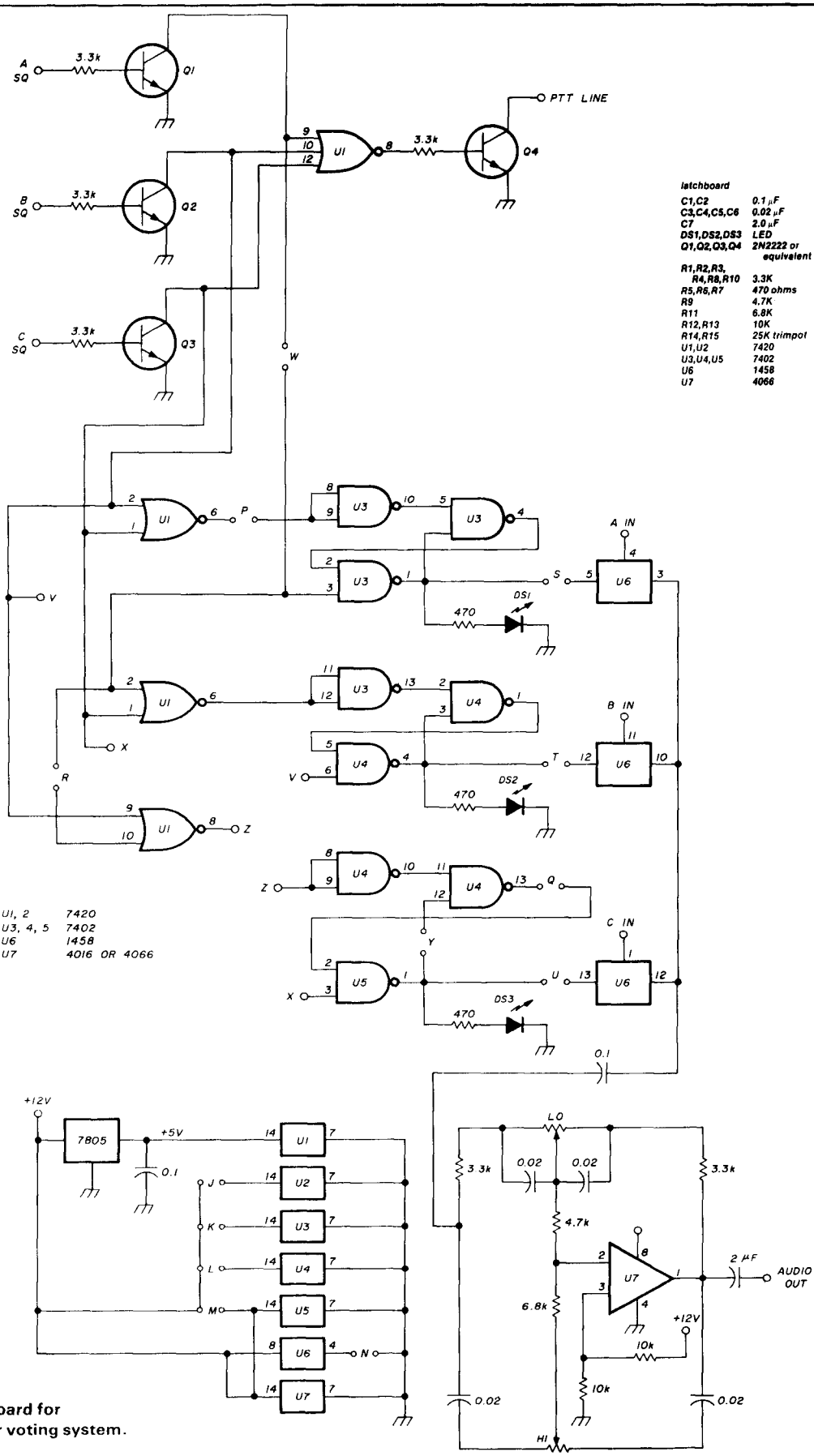

- latchboard**
- C1,C2 0.1  $\mu$ F
  - C3,C4,C5,C6 0.02  $\mu$ F
  - C7 2.0  $\mu$ F
  - DS1,DS2,DS3 LED
  - Q1,Q2,Q3,Q4 2N2222 or equivalent
  - R1,R2,R3, R4,R8,R10 3.3K
  - R5,R6,R7 470 ohms
  - R9 4.7K
  - R11 6.8K
  - R12,R13 10K
  - R14,R15 25K trimpot
  - U1,U2 7420
  - U3,U4,U5 7402
  - U6 1458
  - U7 4066

- U1, 2 7420
- U3, 4, 5 7402
- U6 1458
- U7 4016 OR 4066

fig. 1. Latchboard for three-receiver voting system.

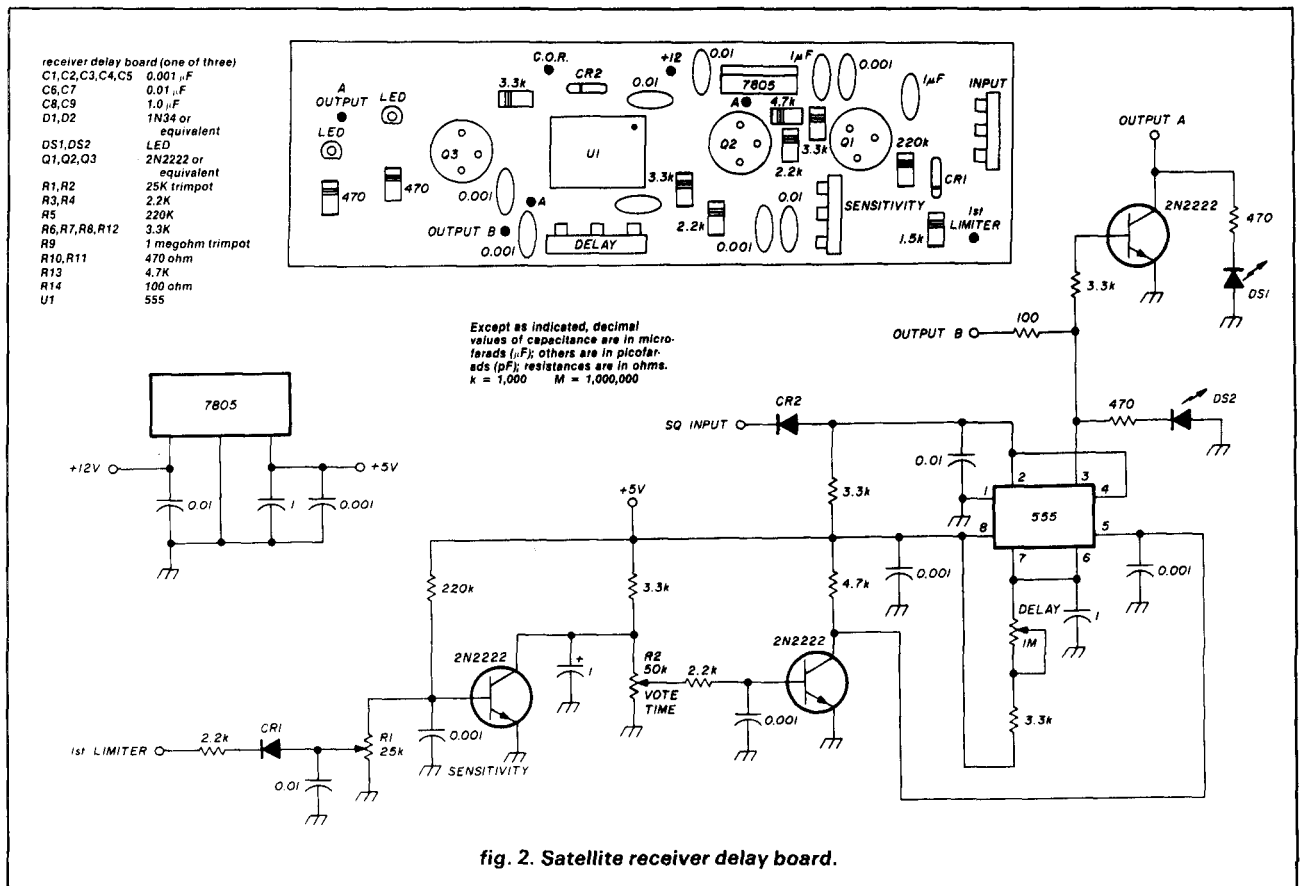

less delays the link transmitter from turning on for up to 0.5 second. Therefore, the first signal the transmitter receives will be the best quieting. When using multiple receiver sites, it is best to adjust the squelch controls of each remote receiver a little tighter than normal.

### latching logic

At the transmitter site, the three link receivers' squelch turns on a dc switch that feeds a series of gates. The gate series accepts the first signal and locks out the other two. This type of priority latching system allows a mobile system to key up more than one of the receiver sites and, as the signal jumps from one site to another, will automatically switch sites. The gates ultimately turn on the PTT transistor which keys the transmitter (fig. 1).

The audio from the three receivers is selected by a 4066 switch. It switches the audio very smoothly. An active audio equalizer which allows loss in frequency response or level during the link process to be made up provides the system with excellent audio quality. The audio mixer/equalizer is an active device that can provide plus or minus 12 dB of dynamic range between 300 and 2000 Hz.

### receiver delay board

The delay board used at each two-meter receiver site uses one LM555 timer IC and three NPN transistors (fig. 2). The limiter voltage from the receiver is fed to the VCO input (pin 5), and the squelch line is fed to the pin 2 control input. If the limiter current is high, meaning the receiver is hearing a very strong signal, the 555 turns on immediately. As the limiter voltage drops, which means a weaker signal is being heard, the 555 will delay turning on for 0.5 second or more. This delay can be adjusted with the 1M pot connected with pin 7 of the 555.

Alignment of the delay board is simple. Read the voltage at the pin 5 test point. Set R1 fully clockwise and R2 fully counterclockwise. Set R3 for a one-second key-up delay. With no signal input, pin 5 will be about 1 volt below VCC. Apply a full quieting signal to the receiver and adjust R2 until pin 5 reads 0.025 volt. Still applying signal, adjust R1 to decrease sensitivity. Decrease R1 enough to raise pin 5 by 0.2 volts, giving a reading at pin 5 at about 0.45 volt. With no signal, pin 5 should read about 3.5 volts. This level is dependent upon the value of VCC. Adjust R3 for the desired delay.



# UHF and VHF RECEIVE CONVERTERS FOR 2 - METER Synthesized Handie - Talkies



## THE ORIGINAL - HANDI-CON Series

Each one of these easy to use converters will turn an average 2-meter, fully synthesized H.T. into an extended coverage receiver. Choose either UHF or VHF PUBLIC SERVICE coverage, or 220MHz AMATEUR coverage.

A micro-processor controlled H.T. can be a hand-held, programmable scanner, thus avoid the expense and bulk of a second receiver for emergency "traffic" and general pleasure monitoring.

• SIMPLE CONNECTION TO RADIO & ANTENNA.

• LOW LOSS TO A NOMINAL 2METER ANT. IN "OFF" MODE.  
• LIGHT WEIGHT.  
• ACCIDENTAL TRANSMIT PROTECTED.

• LOW CONVERSION LOSS.

• SINGLE SWITCH CONTROL.  
• EFFICIENT DESIGN USES 1 AAA CELL.  
• CASE IS BLACK, BRUSH ANODIZE FINISH.  
• LOW COST.



S  
E  
R  
V  
I  
N  
G  
  
C  
R  
E  
A  
T  
I  
N  
G  
  
E  
N  
G  
I  
N  
E  
E  
R  
I  
N  
G

**M - SQUARED  
ENGINEERING, INC.**

1446 LANSING AVE.  
SAN JOSE, CALIFORNIA 95118  
408-266-9214

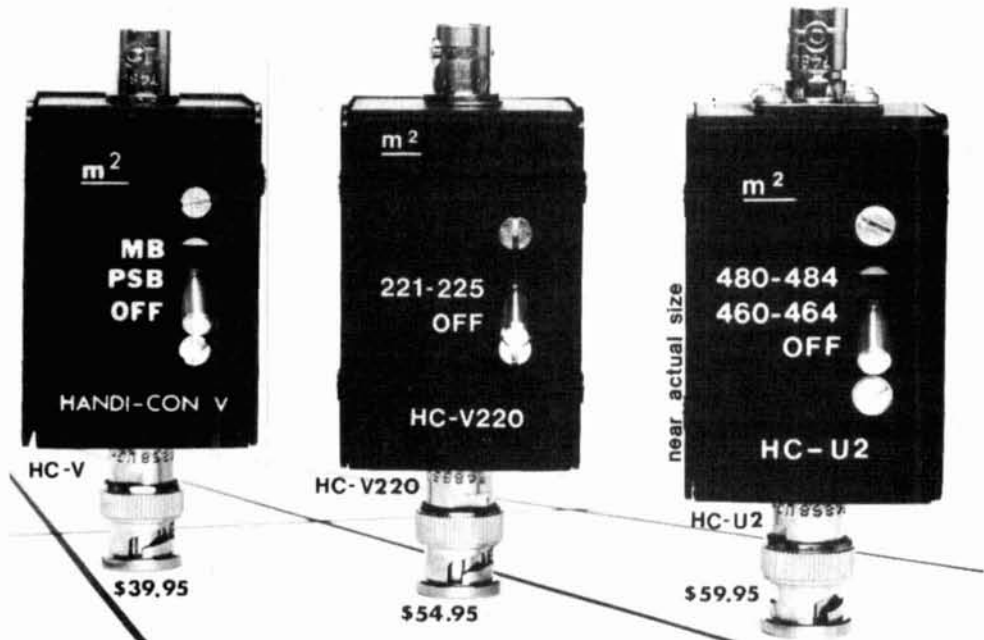

Model No.	HC-V	HC-V220	HC-U2	HC-U2L
Nominal Coverage (MHZ)	154 - 158 (PSB) 159 - 163 (MB)	221 - 225	460 - 464 480 - 484	470 - 474 506 - 510
Type [summary]	Police, fire, other public services. Marine telephone, N.O.A. weather	Amateur	Police, etc.	Police, etc.

NOTE: other frequency groups are available. Contact factory.

## See a dealer near you:

### DEALERS

ACK RADIO SUPPLY, 3101 4th Ave., Birmingham, AL 35233 (205)322-0588  
 AES COMMUNICATIONS, 404 Arrawana St., Colorado Springs, CO 80909 (303)475-7050  
 ARP SYSTEMS, 447 Pine Lake Ave., LaPorte, IN 46350 (219)326-6672  
 AMATEUR RADIO SUPPLY OF NASHVILLE, 615 S. Gallatin Rd., Madison, TN 37115 (615)868-4956  
 ARCO ELECTRONICS, 302 Wyoming Ave., Shavertown, Pa 18708  
 BARRY ELECTRONICS CORP., 512 Broadway, New York, NY 10012 (212)925-7000  
 B. G. CARL ELECTRONICS, 11128 Claire Ave., Northridge, CA 91326 (213)363-1216  
 BETTERTON ELECTRONICS, 5355 Avenida Encinas, Carlsbad, CA 92008  
 BRITTS TWO WAY RADIO, 2508 N. Atlanta Rd., Smyrna, GA 30080 (404)432-8006  
 BRODIE ELECTRONICS CO., 2537 Edgewood Dr., Moore, OK 73160 (405)794-0406  
 BOUGHARDT AMATEUR CENTER, 208 East Kemp Ave., Watertown, SD 57201 (605)886-4534  
 C-COMM, 6115 15th Ave. N.W., Seattle, WA 98107 (206)784-7337  
 COHOON AMATEUR SUPPLY INC., 307 McLeans Ave., Hopkinsville, KY 42240 (502)886-4534  
 EGE INC., 2410 Drexel St., Woodbridge, VA 22192 (703)643-1063  
 ELECTRONICS INTERNATIONAL SERVICE CORP., 11305 Elkin St., Wheaton, MD 20902 (301)946-1088  
 FLOYD ELECTRONICS, 2213 Vandalia St., Collinsville, IL 62234  
 G & K AMATEUR SUPPLY, 2920 E. 9th St., Des Moines, IA 50316  
 HAM RADIO OUTLET, 2620 W. La Palma, Anaheim, CA 92801 (714)761-3033  
 HAM RADIO WORLD, INC., Oneida City Airport, Terminal Bldg., Oriskany, NY 13424  
 THE HAM SHACK, 808 N. Main St., Evansville, IN 47711 (812)422-0231  
 H. I. INC., 1601 Avenue D, Council Bluffs, IA 51502 (712)323-0142  
 J. E. FILBERT, 18 Paradise Court, Palm Bay, FL 32905  
 J. R. S. DISTRIBUTORS, 646 W. Market St., York, PA 17404 (717)854-8624  
 JUNS ELECTRONICS, 3919 Sepulveda Blvd., Culver City, CA 90230 (213)390-8003  
 7352 University, La Mesa, CA 92041 (714)463-1886  
 460 E. Plumb Lane, Reno, NV 89502 (702)827-5732  
 KENS ELECTRONICS, 605 Montgomery St., Napa, CA 94558 (707)224-2493  
 LEW SHER, INC., 213 N. Main, Independence, MO 64050  
 LONG'S ELECTRONICS, 2808 7th Avenue South, Birmingham, AL 35233 (205)252-7589  
 MID-COM ELECTRONICS, 8516 Manchester Rd., Brentwood, MO 63144 (314)961-9990  
 MID-STATE COMMUNICATIONS, 3238 72nd St. E., So. St. Paul, MN 55075  
 MISSOURI COMMUNICATIONS SYS., 2900 N.W. Vivian Rd., Kansas City, MO 64150 (816)741-8118  
 MONROVIA BASIC RADIO, 620 S. Myrtle Ave., Monrovia, CA 91016 (213)359-2986  
 OMAR ELECTRONICS, 11989 East Lansing Rd., Durand, MI 48429 (517)288-2789  
 PORTLAND RADIO SUPPLY, 1234 S. W. Stark St., Portland, OR 97205 (503)228-8647  
 QUEMENT ELECTRONICS, 1000 S. Bascom Ave., San Jose, CA 95128  
 RADIO KING, 25326 S. Crenshaw Blvd., Torrance, CA 90505  
 RADIO MASTERS, 3 Tenafly Rd., Englewood, NJ 07631 (201)568-0738  
 THE RADIO PLACE, 2964 Freeport, Sacramento, CA 95818 (916)441-7388  
 RADIOS UNLIMITED, 1760 Easton Ave., Somerset, NJ 08873 (201)469-4599  
 RADIO WHOLESALE, 2012 Auburn Ave., Columbus, GA 31906 (404)561-7000  
 SATELOID COMMUNICATIONS, 3885 W. 16th Ave., Hillieah, FL 33012  
 UNIVERSAL AMATEUR RADIO, 1280 Aida Dr., Reynoldsburg, OH 43068 (614)866-4267

### DISTRIBUTORS

BCD RADIO PARTS, P.O. Box 119, Richardson, TX 75086  
 INTEGRATED SYSTEMS, 8701 MacAlpine, Garden Grove, CA 92641 (714)539-6555

above prices subject to local sales tax. CAL res. add 6.5 %

The output keying transistor of the delay board will key the 220 link transmitter so no other COR or logic is necessary at the receiver site. The delay board is small enough to mount inside a Motorola or GE receiver strip.

The accuracy of the 555 timing sequence is critical. A normal LM555 is useful from 0 degrees to 70 degrees C. Signetics makes a military spec LM555 which guarantees operation from -70 to +125 degrees C. Use of this device is highly recommended.

### link benefit

This system gives one side benefit. Users of 220 equipment will be able to work two meters with their 220 gear by operating on one of the link frequencies, providing they can hear the link from the main receiver and the transmitter site receiver can hear them. Caution should be observed because there may be times a hand-held or mobile station may key a remote receiver no one is listening to. It is best to be able to monitor all three links to be safe.

### link antenna system

The Marissa system operates their three receivers on a battery back-up system. Only 1 or 2 watts of link power is used and this feeds a seven-element Yagi. After much experimentation, we found that by using horizontal polarization for the link antenna system, we were able to improve the signal-to-noise ratio because most manmade noise is vertical in polarization.

### battery warning beeper

Each receiver site has a warning beeper that activates when the site goes on battery power. One location high atop a grain silo loses commercial power at 5 p.m. each day and all day Sunday. A large tractor battery powers the site when the line voltage is off. To warn the control operators and tech crew that the site is on battery power, a beep sounds every 15 seconds when that receiver site is activated. The tone level is adjusted so it does not interfere with the received signal. Two 555 timers are used to do this (see fig. 3).

### temperature problems

The first winter the system was used turned out to be a real challenge for the tech crew. The 220 rigs were built by Uniden in 1973 and 1974 and marketed under several names. At that time the marketing people thought the 220 band was going to be given to the CB service. The units were not designed to be used in extreme temperature changes. The biggest problems encountered when using them as link components is frequency shifts.

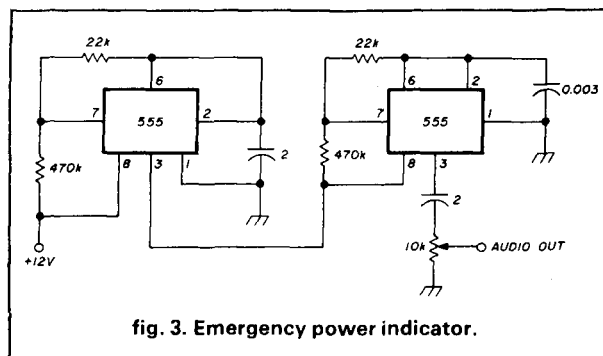

fig. 3. Emergency power indicator.

The problem is the TR-29 oscillator transistor circuit. It was found to be very unstable when operated below 30 degrees Fahrenheit. A simple cure was to mount two small grain of wheat pilot lamps (removed from the front panel of the rig) as close as possible around TR-29. Hold them in place with silicone rubber compound. A 200-ohm resistor is used in series with the lamps to lengthen filament life. This was done around the crystal also. You could install a crystal oven but the pilot lamp trick works well and is much more economical.

### WD9GOE/R

The system at Marissa has three receiver sites. One is thirty-five miles north of the repeater near Scott Air Force Base. The main site is five miles from the repeater transmitter, and the third, thirty-five miles south at Pickneyville. All receivers are Motorola Motran M series. The repeater transmitter runs 200 watts on 147.210 MHz using a General Electric CP-5 final with a 4CX250B. The system has been in operation for about three years and works very well. A similar system is in operation at Gillespie, Illinois, in WR9ACD/R, built by Jim Heyen. We have spent countless hours and shared many ideas on the design of this system.

It is normal to hear two-way hand-held communication across a 50 to 60 mile path. Mobiles enjoy solid 70 to 80 mile coverage. The system also has an elaborate link system with ten-meter fm, and six- and two-meter SSB. It also has voice identification and information tapes, time machine, autopatch, and several other features.

The remote voting receivers have helped to more than triple the coverage of our repeater system. They are inexpensive and require little, if any, maintenance, and will be a worthwhile addition to any system.

### ham radio

The complete kit of drilled PC boards, all parts and instructions are available for \$82.00 (plus \$3 shipping) from Heil, Ltd., P.O. Box 68, Marissa, Illinois 62257. Editor

# HIGH PERFORMANCE 2-METER BEAMS

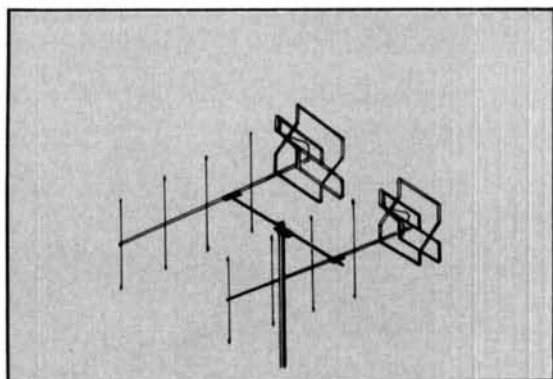

## SQY06W Swiss Quagi

Combines the gain and bandwidth of a phased dual-drive Swiss Quad with the gain of Yagi directors. A 12 element beam.

**\$139.95** + shipping

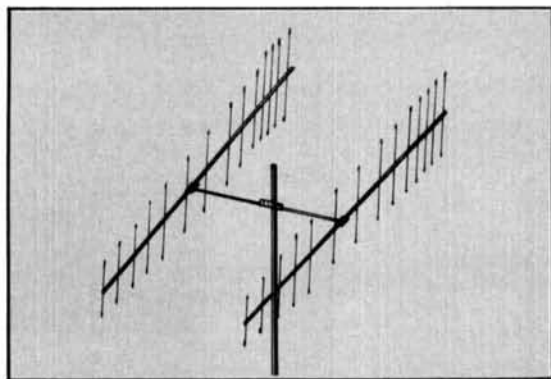

## TE214W Dual Log Yagi

Gives extremely high gain with moderate boom length. A 28 element beam complete with phasing harness and cross support.

**\$204.95** + shipping

Send for free catalog describing our 2-meter high performance beams, Swiss Quads, dual drive tribanders, roof mount towers, elevation rotators and more.

Don't wait any longer to start working real DX. Order your TET beam today.

# TET ANTENNA SYSTEMS

BY MAIL:  
TET Antenna Systems  
1924-E W. Mission Road  
Escondido, CA 92025



BY PHONE: 714-743-7025

## PROGRAMMABLE CTCSS ENCODER



**\$26<sup>95</sup>**

- All 37 EIA Tones
- Quartz Accurate
- Less than 1 inch square

AVAILABLE FOR IMMEDIATE DELIVERY  
For more information call TOLL-FREE

(800) 828-6884

NY: (800) 462-7242

CANADA: (416) 884-3180



**FERRITRONICS**  
MOBILE DATA SYSTEMS

1319 PINE AVE.  
NIAGARA FALLS NY 14301  
(716) 282-7470 TLX 64-6303



## FAST SCAN

**\*\$249**

A modular approach... for your own custom-designed ATV system... Here's how

**TXA5-4 ATV EXCITER/MODULATOR \$89 ppd**



This wired and tested module is designed to drive the Motorola MHW-710 module in the PA5 10 watt linear amp. The crystal in the 100 mHz region keeps harmonics out of two meters for talk back. The video modulator is full 8 mHz for computer graphics and color. Requires 13.8 vdc reg @ 70 ma. Tuned with xtal on 439.25, 434.0, or 426.25 mHz. Provision for sync expanding. Two frequencies available.

**PA5 10 WATT ATV POWER MODULE \$89 ppd**

The PA5 will put out 10 watts RMS power on the sync tips when driven with 60 mw by the TXA5 exciter. 50 ohms in and out, plus bandwidth for the whole band with good linearity for color and sound. Requires 13.8 vdc regulated @ 3 amps.



**FMA5 AUDIO SUBCARRIER GENERATOR \$29 ppd**



Puts audio on with your camera video just as broadcast TV does at 4.5 mHz. Puts out up to 1 v p p to drive the TXA5 or VM-2, 3, or 4 modulators. Requires low Z mic (150 to 600 ohms), and +12 to 18 vdc @ 25 ma. Works with any xmt with 5 mHz video bandwidth.

**TVC-2 ATV DOWNCONVERTER... \$55 ppd**

Stripline MRF901 (1.7 db NF) preamp and double balanced mixer module digs out the weak ones but resists intermods and overload. Connects between uhf antenna and TV set tuned to channel 2 or 3. Varicap tunes 420 to 450 mHz. Requires +12 to 18 vdc @ 20 ma. Super sensitive TVC-2L with NE64535 preamp (9db NF) stage. \$69 ppd



**\*TXA5, PA5, FMA5 and TVC Basic Module Pkg.**

Call or write for our complete list of specifications, station set-up diagrams, and optional accessories which include antennas, modulators, detectors, test generators, cameras, etc. **WE ARE A FULL-LINE SUPPLIER OF ALL YOUR ATV NEEDS.**

TERMS: VISA or MASTER CARD by telephone or mail, or check or money order by mail. All prices are delivered in USA. Allow three weeks after order for delivery.

(213) 447-4565 Charge card orders only

## P.C. ELECTRONICS

Tom W6ORG Maryann WB6YSS

2522 Paxson Lane,  
Arcadia, California 91006

# the simple simplex autopatch

Mix a transceiver,  
some parts and ingenuity  
to build this simple device

Many repeaters in the Amateur service employ a method of accessing the telephone system. Usefulness of this autopatch feature is reduced if the repeater is often used for normal communications. It is my experience that commercial autopatch systems are very costly and home-brew units can get quite complicated. A simpler and cheaper autopatch may be built around an available VHF/UHF transceiver by using a different method.

## the simplex concept

The most expensive part of a repeater autopatch is the repeater itself. A significant cost reduction is realized by using simplex communication; transmitter and receiver do not have to operate simultaneously. This concept eliminates many problems since no antenna duplexer is needed, only one antenna is required, and a standard transceiver may be used.

The simplex concept has a problem: if the telephone side of the conversation is being transmitted by the patch, how does it determine when the primary user wants to talk? When should the system switch to receive?

One common design in commercial systems switches to receive whenever the person using the telephone stops talking. The person using the radio is now free to begin transmitting into the patch. This method is unsuitable in Amateur radio service since the ham must have complete control over all rf transmission, including the autopatch.

Another method of transmit/receive control is to switch the patch transceiver periodically into a brief

receive window. The window checks the frequency for presence of a carrier, presumably signifying that the ham user wants to talk. If the carrier is present, the patch will remain in the receive mode until the carrier disappears. If no carrier is present during the receive window, the patch system immediately resumes transmitting until the next window test. No part of the telephone conversation is lost if these windows are brief.

A complete simplex autopatch system consists of four major components: the controller and telephone interface, the transceiver, a power supply, and an antenna. This article describes the controller in detail and shows how a complete system can be built around an ICOM IC-230 transceiver.

The controller is a dedicated unit and *not* microprocessor-based. I found that standard TTL provides a simpler control unit that is easy to trouble-shoot. Those of you without access to a PROM programmer will be relieved to know that this project does not require memory programming!

The patch circuitry is relatively simple but boasts such useful features as an automatic identifier, time-out circuitry, and full monitor capability. It can still be used as a normal transceiver even though the rig requires some squelch modification.

## the controller

The control unit is the heart of the simple simplex autopatch. It performs the connect and disconnect functions between telephone and transceiver. It also generates the receive window for transmit/receive control and provides the CW identifier. Time-out circuitry and an audio monitor are included.

The controller is the small chassis on top of the IC-230 in fig. 1 and operates from the same 12 Vdc supply as the transceiver. My system is powered by a battery to avoid problems when power is not available.

A block diagram of the controller is shown in fig. 2

By Robert K. Morrow, Jr., WB6GTM, 9792  
Oma Place, Garden Grove, California 92641

with the main schematic in **fig. 3**. Identifier, reset, and power supply sections are detailed in **fig. 4**. **Fig. 5** shows the inside view of the controller chassis. Three tone decoders control telephone line connect and disconnect. The timeout section will switch the system to standby if the patch remains on for about two minutes with no incoming signal interruptions. The receive window generator section is described later.



**fig. 1.** The Simplex Autopatch System. The autopatch controller is the small chassis on top of the ICOM IC-2302-meter transceiver. The battery is optional and allows continued operation after power failure.

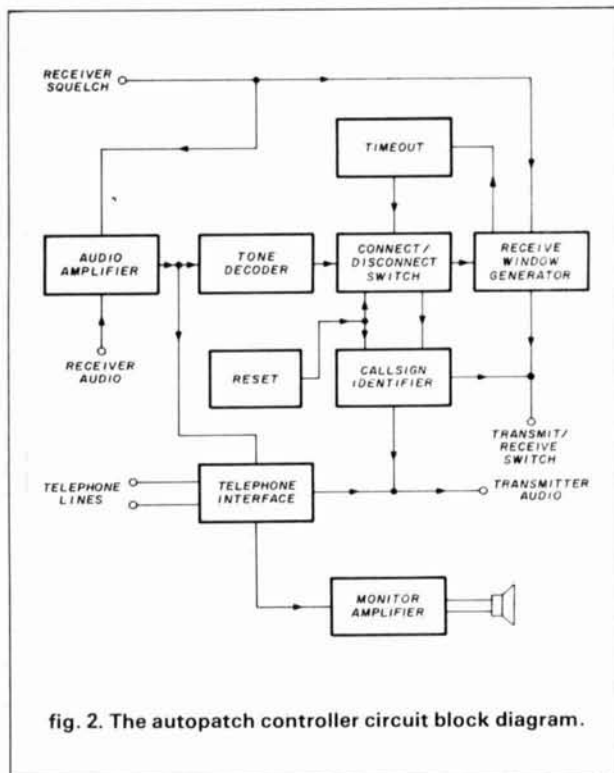

**fig. 2.** The autopatch controller circuit block diagram.

## audio

Transceiver audio is taken from the receiver's discriminator so that audio into the controller is independent of the transceiver volume control setting. This low-level audio signal is amplified by U1 and sent to the telephone line through transmit/receive relay K2 and isolation transformers T1 and T2. Receiver audio also goes to monitor amplifier U2 and three tone decoders, U5 to U7.

Telephone line connection is from the red and green wires through line-connect relay K1. One line isolation transformer with 600 ohm impedance on each winding is normal. I used two Radio Shack units wired back-to-back, since they were inexpensive and easy to find.

The 567 tone decoder has a reputation for false triggering. I made an attempt to improve reliability in two ways: first, transistor Q1 turns off U1 whenever the receiver is squelched so that noise cannot activate the decoders. Second, the 567 switching speed is slowed by the 10  $\mu$ F capacitor to pin 1 of each chip. The tone must be present for about one-third second to activate the decoders.

## beginning the control sequence

U9A in **fig. 3** is a D-type flip-flop that holds the most recent tone command, either connect or disconnect. A connect command is applied directly to the preset input while the disconnect command resets U9A through its clock input, pin 3. The clear input at pin 1 is activated by the RESET (from **fig. 4**) or the time-out from U12. This configuration saves a gate since the RESET and disconnect signals, while performing the same function, are applied to different pins on the flip-flop. Gate conservation is important: every gate in any package is in use!

It should be noted that HI and LO markings in **fig. 3** are the TTL logic levels for the particular function. Audio amplitude levels are given later under control circuit alignment.

Flip-flop U9B is set each time a connect or disconnect command is decoded.\* When either command disappears and the receiver squelch is on via inverter Q2, gate U4D starts the identification (ID) sequence by clearing U19B (**fig. 4**). U9B is cleared through D5 when the ID begins. This interconnection causes an automatic ID transmission at the beginning and end of each time period the patch is used. If each phone call is limited to ten minutes, identification requirements are fulfilled.

Telephone line connect relay K1 will pick up when both bases of Q6 and Q7 are pulled low. This occurs when the patch has been activated (U9A set) and the

\*U8B and U8A will OR high inputs without inverting the output; when either output returns low, U4A output goes high to clock U9B on the positive-going edge. Editor

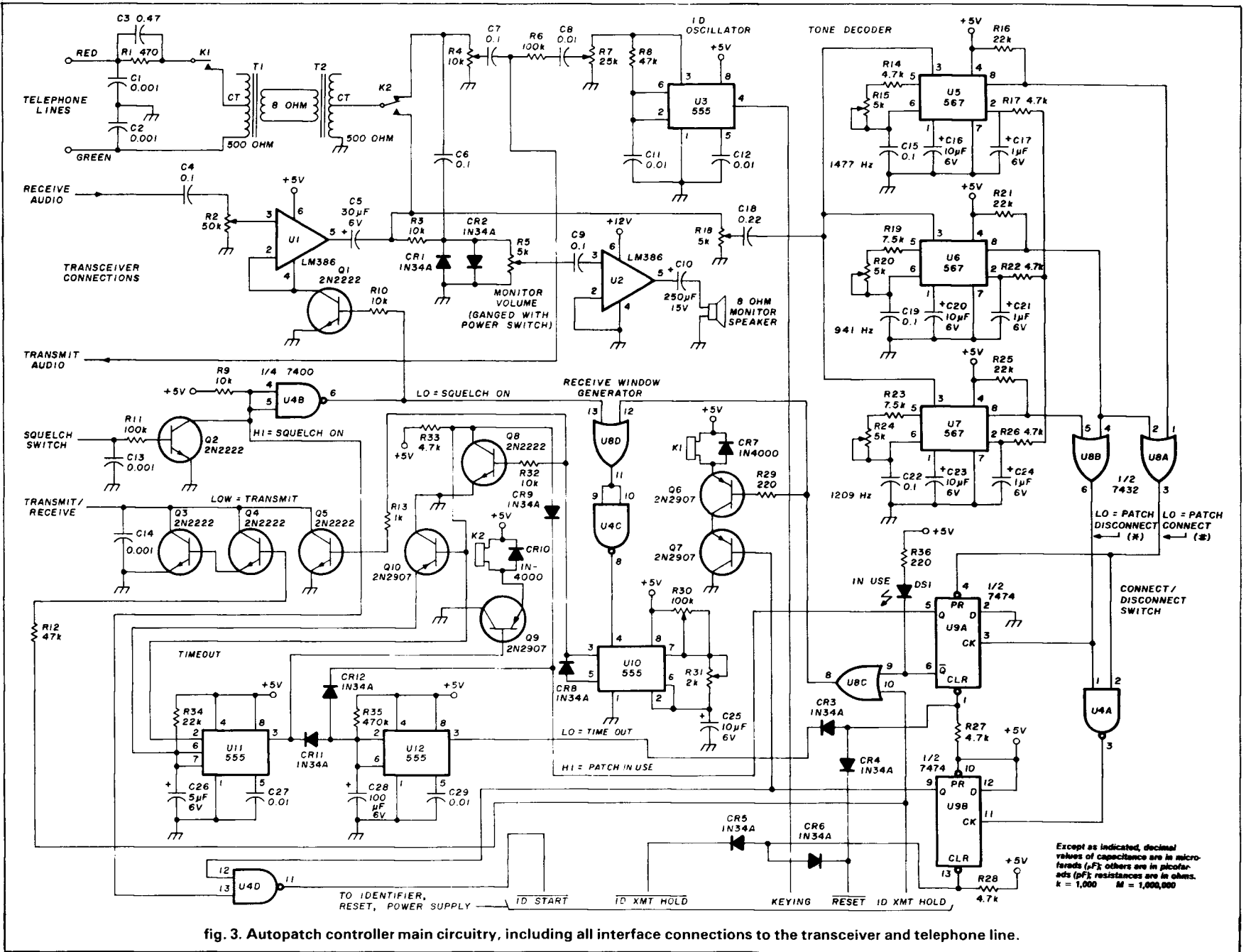

fig. 3. Autopatch controller main circuitry, including all interface connections to the transceiver and telephone line.

**table 1. Parts List.**

**Resistors, 1/4 Watt, 10 percent unless noted**

R1	470, 1/2 Watt
R2	50K trimmer potentiometer
R3,R9,R10,R32	10K
R4	10K trimmer potentiometer
R5	5K panel-mount potentiometer
R7	25K trimmer potentiometer
R8,R12,R38	47K
R6,R11	100K
R13	1K
R14,R17,R22,R26, R27,R28,R33,R40,R41	4.7K
R15,R18,R20,R24	5K trimmer potentiometer
R16,R21,R25,R34	22K
R19,R23	7.5K
R29,R36	220
R30	100K trimmer potentiometer
R31	2K trimmer potentiometer
R37	680
R39	470K

**Capacitors,  $\mu$ F, 15 V Disc unless noted**

C1,C2	.001, 250 V minimum, disc
C3	.47
C4,C6,C7,C9	0.1
C5	30, 6 V electrolytic
C8,C11,C12,C27, C29,C33,C35	.01
C13,C14	.001
C15,C19,C22	0.1 polystyrene or metal film, temperature stable, Radio Shack 272-1053
C16,C20,C23,C25	10, 6 V electrolytic
C17,C21,C24,C31, C32,C34	1, 6 V electrolytic

C18	0.22
C26	5, 6 V electrolytic
C28	100, 6 V electrolytic
C30	1, 15 V electrolytic

**Transistors**

Q1,Q2,Q3,Q4, Q5,Q8	2N2222 or equivalent NPN
Q6,Q7,Q9,Q10	2N2907 or equivalent PNP

**Integrated Circuits**

U1,U2	LM386N-1
U3,U10,U11,U12, U14,U17	LM555J
U4,U16	7400
U5,U6,U7	LM567N
U8	7432
U9	7474
U13	LM309K
U15	7473
U18	7493
U19	7476
U20,U21	74154

**Diodes**

CR1 to CR6,CR8, CR9,CR11,CR12	1N34A or equivalent germanium
CR7,CR10	1N4000 or equivalent
DS1,DS2	16 mA LED, panel-mount
K1,K2	SPDT contacts, 5 Vdc coil, 56 ohms, Radio Shack 275-216
S1	SPST push button
S2	SPST 1 Ampere (ganged with R5
T1,T2	1000 ohm C.T.: 8 ohm, Radio Shack 273-1380

ID sequence has finished transmitting (U9B clear and U8C-10 low). K1 drops out on a disconnect command when U9A is cleared.

**the receive window**

Timer U10 is wired as an astable multivibrator, operating when the patch is activated and the receiver squelch is on (U10-4 high through U4C and U8D). When the timer output at pin 3 is high, it turns on the patch transmitter through Q5. The transmit/receive line is also held low for transmit during the ID sequence via Q4 and Q3.

If the squelch is tripped during the window provided by the low period of U10-3, reset pin 4 is brought low and turns off timer U10. The receiver will remain on. R30 adjusts the length of the receive window and R31 sets the time between windows. The diode on pins 3 and 5 of U10 ensures that the first pulse of the timer is the same length as all subsequent pulses.

Note that this circuit requires the transceiver to provide a low voltage level for receiver squelch and that the transmit control line should also be at a low voltage level. If your transceiver requires opposite levels, transistor inverter circuits such as Q2 (low current) or Q5 (high current) may be used for the correct level.

The squelch line should stay at the squelch-on level during transmit. This is the case for most transceivers, but if your rig is different, additional squelch gating is required.

**time-out circuit**

The time-out circuit will shut off the autopatch if it is allowed to transmit continuously for about two minutes. Timer U11 is configured as a missing pulse detector; output is high during transmit. While U11-3 remains high, the input voltage to the Schmitt trigger (U12) will gradually increase to three and a third volts through R35 and C28. U12-3 will go low when this

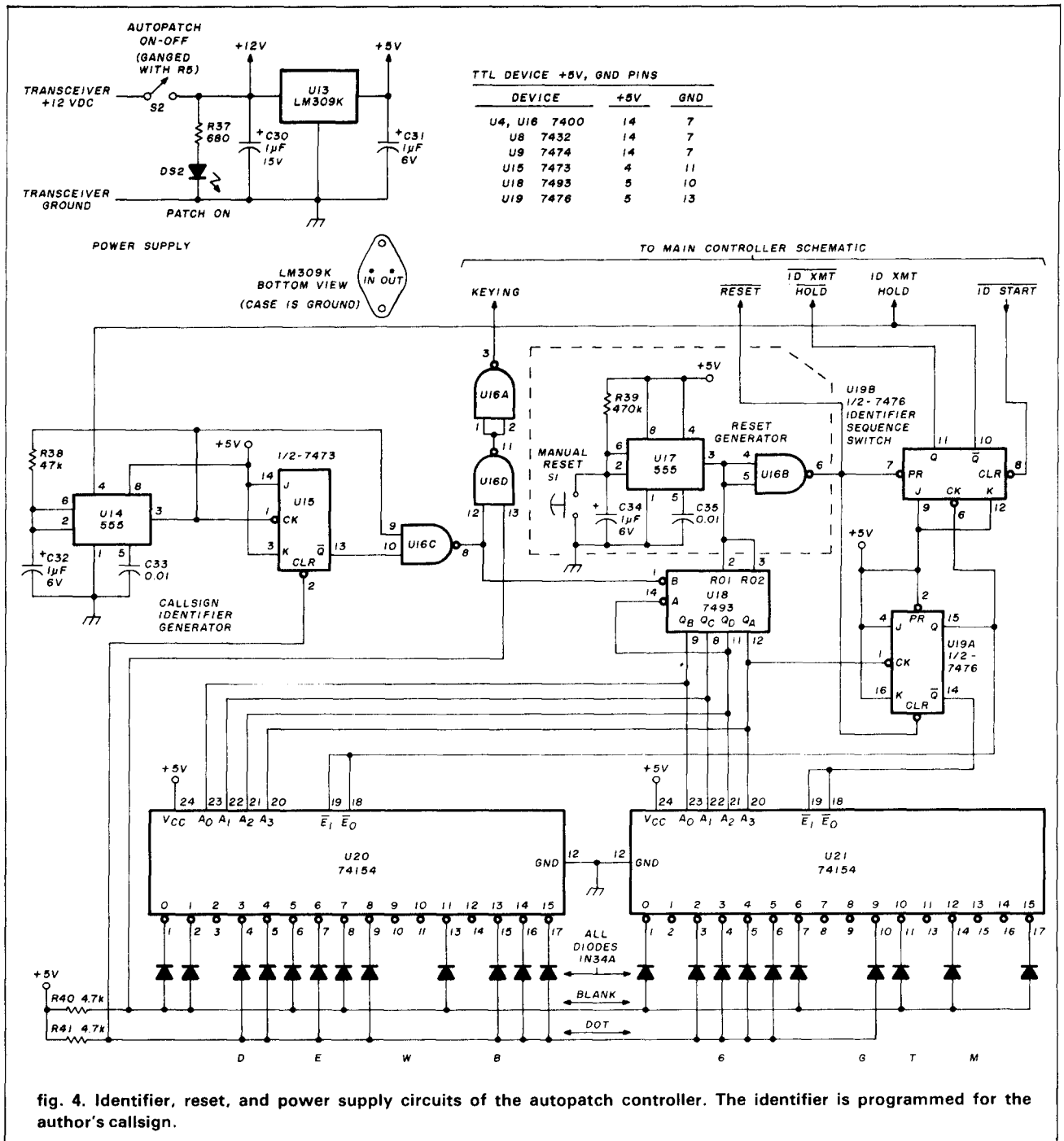

fig. 4. Identifier, reset, and power supply circuits of the autopatch controller. The identifier is programmed for the author's callsign.

voltage is reached, turning the patch off by clearing U9A.

Interrupting the pulses into U11 before two minutes have elapsed will allow C28 to discharge rapidly through CR11 and U11. The time-out cycle is reset. This occurs each time the receiver remains un-squelched longer than the pulse width set by R34 and C26. That width must be longer than the receiver window set by R31. I chose the values of R34 and

C26 for any reasonable window width; they should not require adjustment.

You may be wondering why the time-out circuit appears so complex. Why not connect the inverted squelch directly to R35 and C28? The IC-230 and some other transceivers will momentarily un-squelch the receiver when the transmitter turns off during the receive window. This has the effect of periodically discharging C28 and makes the time-out feature use-



# Alaska Microwave Labs

P.O. BOX 2049 PALMER, ALASKA 99645  
(907) 376-3098 DEPT HR

## GaAs FETS

MGF1400 NF 2.0DB @ 4GHZ MAG 15DB	\$14.00
MGF1412 NF 0.8DB @ 4GHZ MAG 18DB	\$50.00
MCF1200 NF 1.0DB @ 1GHZ, NF 2.2DB @ MAG 14DB @ 4GHZ	\$11.00

## VTO

V72T-1 2.7GHZ TO 3.2GHZ MIN POWER OUT 10 MW TUNING VOLTAGE 0 TO 20V Vcc +15 vdc at 60 MA	\$98.00
V72T-2 2.8GHZ TO 3.3GHZ REST SAME AS V72T-1	\$98.00
V82T-1 SAME AS V72T-1 BUT FREQ 3.0GHZ TO 3.5GHZ	\$98.00
V82T-2 SAME AS V72T-1 BUT FREQ 3.6GHZ TO 4.2GHZ	\$98.00
V82T-3 SAME AS V72T-1 BUT FREQ 4.0GHZ TO 4.5GHZ	\$98.00
V92T-1 SAME AS V72T-1 BUT FREQ 4.5GHZ TO 5.0GHZ	\$98.00
V56T-1 9GHZ TO 1.6GHZ POWER OUT 13 MW TUNING VOLTAGE 2 TO 50V Vcc +15 VDC AT 60 MA	\$98.00
V66T-1 SAME AS V56T-1 BUT FREQ 1.5GHZ TO 2.5GHZ	\$98.00

## CHIP CAPACITORS

1.2, 2.2, 2.7, 3.3, 4.7, 6.8, 10, 18, 22, 27, 47, 100, 120, 180, 220, 270, 330, 390, 470, 560, 680, 820, 1K, 1.2K, 1.8K, 3.9K, 8.2K, 10K, 100K	\$6.00
--	--------

## PISTON TRIMMERS

TRIKO 201-01M	
3-1.8PF	\$2.50
5-3 PF	\$2.50
1-8 PF	\$2.50

## TEFLON CIRCUIT BOARD DBL SIDED 1 OZ

APPROX. 3.25" x 5.0" x .010	\$5.50
APPROX. 3.25" x 5.0" x .0312	\$6.50
APPROX. 3.25" x 5.0" x .0625	\$10.50

## MIXERS

3.7GHZ TO 4.2GHZ MIXER, LO 2.8GHZ TO 5.1GHZ, IF DC-9GHZ SSB CONVERSION LOSS TYP 5.5DB MAX 6.5DB, TO-8 PACKAGE	\$55.00
9GHZ TO 1.3GHZ MIXER, LO 7GHZ TO 1.5GHZ, IF DC-2GHZ SSB CONVERSION LOSS TYPE 7.0DB, TO-8 PACKAGE	\$15.00

## CHIP RESISTORS

50 OHM 1/2 WATT	\$1.50
3 1% CHIP RESISTORS FOR:	
50 OHM T NETWORK 3 DB PAD	\$6.00

NO WARRANTY ON SEMICONDUCTORS

OPEN AT 8 PM EST CLOSED 8PM PST  
ORDERS ARE POSTAGE PAID  
COD - VISA - MASTERCARD



# HAL COMMUNICATIONS SUPER SALE!



**CT2100 and KB2100**

**List Price: \$1020**

**Save \$141!**

**Both Units Only \$879**

Standard 12" Green Screen Monitor \$111  
High-Resolution Green Screen Monitor \$169

**CWR6850 List Price: \$995**  
**Complete Unit with Keyboard**  
**on Sale at \$869!**

**CWR6700**  
**Receive Only Telereader**  
**List Price: \$495 Sale Price: \$439!**



**DS3100ASR**  
**List Price: \$2195 Sale Price: \$1799!**

MSO3100 Option Only \$333  
When Purchased With DS3100! (List Price: \$595)

**ST6000 Deluxe Demod Keyer**  
**List Price: \$749 Sale Price: \$649!**

Save Over \$750 On Complete System!

**DS2050KSR**  
Compact RTTY System Complete With  
Keyboard, Demod, Loop Supply  
**List Price: \$649**  
**Sale Price: \$569! Save: \$80**

Optional 12" Green Screen Monitor \$111  
12" High-Resolution Green Screen Monitor \$169



## Auxiliary Equipment

	List	Sale
ST5000 Demodulator/Keyer	\$249.	\$219
ST6000 Deluxe Demodulator/Keyer (Recommended for DS3100)	\$749.	\$649
RS 2100 2" Scope w/Loop	\$329.	\$289
BMC 12AU 12" Monitor	\$189.	\$111
BMC 12EU 12" High-Resolution Monitor	\$249.	\$169
C-1 DS3100/ST6000 Cable Kit	\$ 50	
C-2 CT2100/DS2050/CWR6850 Cable Kit	\$ 25	
OKI-DATA 82A Printer	\$650.	\$589
256 Character Buffer	\$130	
2K Character Buffer	\$150	

**FREE! FREE! FREE! FREE! FREE!**

**SEND FOR OUR NEW  
1982/1983 PARTS CATALOG**

THOUSANDS OF SURPLUS  
ELECTRONIC PARTS, SUPPLIES  
AND DEVICES.

**ALL ELECTRONICS CORP**  
905 S. Vermont Ave  
P.O. Box 20406  
Los Angeles, Cal. 90006

**FREE! FREE! FREE! FREE! FREE!**

THE BEST PLACE TO BUY, SELL or  
TRADE NEW and USED EQUIPMENT

**NUTS & VOLTS MAGAZINE**  
BOX 11111-H • PLACENTIA, CA 92670  
(714) 632-7721

Join Thousands of Readers Nationwide  
Every Month

**ONE YEAR U.S. SUBSCRIPTIONS**  
\$7.00 - 3rd Class • \$12.50 - 1st Class

**\$25.00 - Lifetime - 3rd Class**

**NUTS & VOLTS**

HAM GEAR  
COMPUTERS  
SOFTWARE  
SCANNERS • OPTICS  
TEST EQUIPMENT  
MICROWAVE  
SATELLITE  
AUDIO VISUAL  
NEW PRODUCTS  
COMPONENTS • KITS  
ANTIQUE ELECT.  
PUBLICATIONS  
PLANS • SERVICES

**DIPLOLE ANTENNA CONNECTOR**

HYE-QUE (HQ-1) dipole connector has coax  
SO-238 socket molded into glass filled plastic  
body to accept coax PL-259 plug on feedline.  
Drip-cap keeps coax fittings dry. Instructions in-  
cluded. Guaranteed. At your dealers or \$5.95  
postpaid. Companion insulators \$1.25/pr.

**BUDWIG MFG. Co.** PO Box 829, Ramona, CA 92065  
Ca. Res. add 6% Sales Tax

# TEXAS TOWERS

DIV. OF TEXAS RF DISTRIBUTORS INC.

**1108 Summit Ave., Suite 4 / Plano, Texas 75074**

Mon.-Fri.: 8:30 a.m. - 5:30 p.m. Sat. 9 a.m. - 1 p.m.

**TELEPHONE: (214) 422-7306**



ALL PRICES AND SPECIFICATIONS SUBJECT TO CHANGE WITHOUT NOTICE

# Long's starts the New Year off right!

## COMMODORE VIC-20 personal computer with 5K memory

The VIC-20 offers more dollar-for-dollar performance than any other personal computer. It has built-in BASIC language, 5K of RAM (expandable to 32K) high resolution graphics, sound, color and a wide range of add-on accessories. Full size keyboard features 64 ASCII character set, numerics and business/calculation symbols. Screen display 22 characters wide by 23 lines deep. Program line length 88 characters. Will accept plug-in program cartridges, floppy disc and cassette storage systems.

List Price 299.00  
**178.00** Item No. COMVIC20  
 Add 3.50 shipping & handling



## KANTRONICS THE INTERFACE RTTY/CW/ASCII to computer adaptor

Transforms your personal computer into a complete CW/RTTY/ASCII send and receive terminal with The Interface linking it to your transceiver. Active filter at 2295 Hz for RTTY and 750 Hz for CW. LED bar graph for fast and easy tuning. Hamsoft package required for VIC-20.

List Price 189.95  
**170.95** Item No. KANINTERFACE  
 Add 1.75 shipping & handling



## AEA MBA-RO Morse, RTTY, ASCII reader

Attaches to the speaker terminals of a receiver and displays Morse, RTTY, or ASCII on its 32 character 0.29" high display screen. Compact size only 8 3/4" x 5 1/2" x 2". A great way to monitor one's sending proficiency. Power requirement 1.3V DC @ 500 ma.

List Price 299.95  
**269.95** Item No. AEAMBARO  
 Add 2.33 shipping & handling

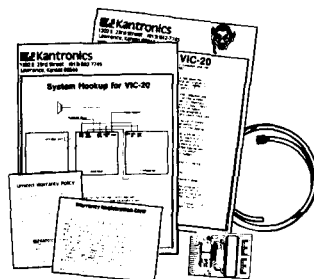

## KANTRONICS Hamsoft package

The necessary software for connecting The Interface to the VIC-20. Includes VIC-20 program board & the needed cables. Allows your computer to have a split screen display, scrolling receive display, 1024 character type ahead buffer and more!

List Price 59.95  
**49.95** Item No. KANVIC20  
 Add 1.38 shipping & handling

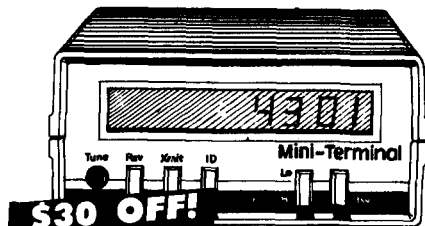

## KANTRONICS Mini Terminal

Sends and receives Morse code, RTTY, and ASCII. Converts any CW input from a CW keyer or keyboard into standard 2 tone RTTY or ASCII. Terminal transmits at 60, 75, 100 on RTTY and 110 on ASCII. Epson MX-80 or Paper Tiger may be attached for hard copy.

List Price 299.95  
**269.95** Item No. KANMINITERM  
 Add 1.75 shipping & handling

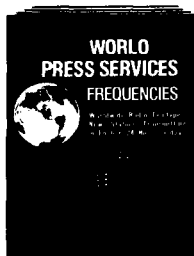

## "WORLD PRESS SERVICES FREQUENCIES" listings of RTTY transmissions

A true storehouse of information for the RTTY specialized amateur of SWL. Publication lists AP, UPI, Reuters, TASS, VOA, London Press, and other active press RTTY frequencies from around the world. Lists over 65 news and press services. Great for code reader users!

List Price 9.95  
**7.95** Item No. BOORTTY  
 Add 1.36 shipping & handling

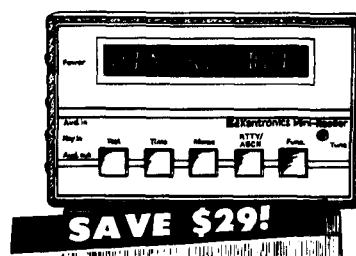

## KANTRONICS Mini Reader

A code reader the size of a calculator! Measures only 5 1/4" x 3 1/2" x 1". 10 digit 3/8" high character display. Copy Morse, RTTY, or ASCII from the palm of your hand. Features automatic Morse speed tracking, and 24 hour clock. Comes with display stand and AC adaptor.

List Price 289.95  
**260.95** Item No. KANMINIREADER  
 Add 1.75 shipping & handling

# Long's Electronics



MAIL ORDERS: P.O. BOX 11347 BIRMINGHAM, AL 35202 • STREET ADDRESS: 3131 4TH AVENUE SOUTH BIRMINGHAM, AL 35233

# Complete satellite TV system \$1795!

## 10 FT. PARABOLIC DISH

List Price 3985.00  
Item No. MISSY87  
Shipped Freight Collect

### What the system will do:

You can receive up to 60 channels of TV direct from satellites to your home receiver. Movies, sporting events, religious programs, other TV stations and much more.

### What the system includes:

1. 10 ft. fiberglass dish made of reflective metal bonded with fiberglass. Weather resistant and virtually maintenance-free. Comes in 4 sections for easy assembly.
2. Single-pole polar mount complete with azimuth and elevation adjustments for easy satellite-to-satellite tracking.
3. LNA mount complete with rotor for adjusting horizontal and vertical polarity of LNA. Extension poles not included.
4. KLM SS-22 receiver. Consists of two parts: receiver and downconverter. The receiver can be placed indoors and linked to the downconverter by remote cable. Features scan, video inversion, LED signal strength indicator, fine tuning and audio level control.
5. Avantek 4215 120° low noise amplifier. Takes weak signals reflected by the dish and amplifies them so that they can be converted to a TV picture. Uses GaAs FET transistors and has its own built-in power source. Urethane coated.
6. Chaparral feed horn. Provides 0.5 dB gain improvement over conventional rectangular horns for superior picture and sound quality. Virtually eliminates system noise.

**Note:** Customer provides all cables. Approximate cost \$80. Customer must feed audio and video through VCR or use RF modulator (\$59).



## Read all about Satellite TV!

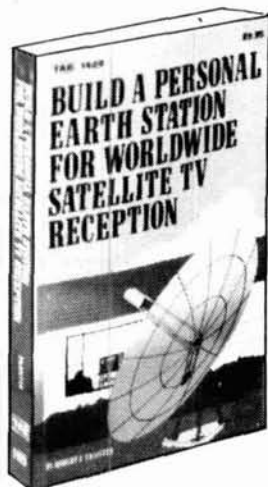

Learn to:

- Design
- Operate
- Build
- Maintain

9.95

Add 1.36 shipping & handling  
Item No. BOOTAB1409

At last! A complete guide to satellite TV!  
"Build a Personal Earth Station for Worldwide  
Satellite TV Reception"

A complete guide to gaining access to the large amount of TV programming available from satellite transmissions. You can choose to build your own system or purchase one ready-to-operate, and both ways are thoroughly covered in this book. It begins with a review of basic television fundamentals and satellite transmission and reception. Building your own system is covered and the complicated task of installing the antenna and aiming it to pick up the signals you want is simplified. There's even a complete list of available satellite programming.

Call Toll Free **1-800-633-3410**

IN ALABAMA CALL 1-800-292-8668 9 AM TIL 5:30 PM CST, MONDAY THRU FRIDAY

## SWR & Power Meter



- The most advanced automatic computing RF measuring instrument in amateur radio.
- Logarithmic SWR scale.
- Power ranges 20/200/2000 watts.
- Frequency range 1-30 MHz.

**Automatic.** No "set" or "sensitivity" control. Computer sets full scale so SWR reading is always right. Complete hands-off operation.

**Light bar display.** Gives instant response so you can see SSB power peaks. Much faster than old-fashioned panel meters. Baton switch selects three power ranges.

**Logarithmic SWR display.** Computer expands the display where you need it so it's easier to see, easy to use.

**Computer operated.** Now an analog computing circuit and digital comparator automatically compute SWR regardless of power level. Frees you from checking zero, setting a "sensitivity" knob and from squinting at old-fashioned cross pointer mechanical meters. With this new meter computing is done electronically and displayed with moving light bars. Individual bars for SWR and power.

**Model M-827 Automatic SWR & Power Meter** \$119.95 in the U.S. and Canada. Add \$3 shipping/handling. California residents add sales tax.



### ORDER YOURS NOW!

Send for FREE catalog describing the SWR & Power Meter and our complete line of Noise Bridges, Pre-amplifiers, Toroids, Baluns, Tuners, VLF Converters, Loop Antennas and Keys.

# Palomar Engineers

1924-F West Mission Rd.  
Escondido, CA 92025  
Phone: (619) 747-3343

When it comes to  
**QSL's...**



it's the  
**ONLY BOOK!**

US or Foreign Listings

1983  
**callbooks**  
NOW READY!

Here they are! The latest editions of the world-famous Radio Amateur Callbook are available now. The U.S. edition features over 400,000 listings, with over 75,000 changes from last year. The Foreign edition has over 370,000 listings, over 50,000 changes. Each book lists calls and the address information you need to send QSL's. Special features include call changes, census of amateur licenses, world-wide QSL bureaus, prefixes of the world, international postal rates, and much more. Place your order for the new 1983 Radio Amateur Callbooks, available now.

	Each	Shipping	Total
<input type="checkbox"/> US Callbook	\$19.95	\$3.05	\$23.00
<input type="checkbox"/> Foreign Callbook	\$18.95	\$3.05	\$22.00

Order both books at the same time for \$41.95 including shipping.

Order from your dealer or directly from the publisher. All direct orders add shipping charge. Foreign residents add \$4.55 for shipping. Illinois residents add 5% sales tax.



### SPECIAL OFFER!

Amateur Radio  
Emblem Patch  
only \$2.50 postpaid

Pegasus on blue field, red lettering. 3" wide x 3" high. Great on Jackets and caps.

ORDER TODAY!

RADIO AMATEUR  
**callbook** INC.



Dept. F  
925 Sherwood Drive  
Lake Bluff, IL 60044, USA



July 30 thru August 12, 1983

Our 24th year

Learn why the answers are what they are. Upgrade with electronics professionals.

**OAK HILL ACADEMY RADIO SESSION**  
in the  
**Blue Ridge Mountains of Virginia**

Theory and code together.

- Novice to General
- General or Technician to Advanced
- Advanced to Amateur Extra

Expert Instructors — Friendly Surroundings — Excellent Accommodations.

Ham Lab set up for all to use.

"A Vacation with a Purpose"

C. L. PETERS, K4DNJ, Director  
Oak Hill Academy Amateur Radio Session  
Box 43  
Mouth of Wilson, VA 24363

Name \_\_\_\_\_ Call \_\_\_\_\_

Address \_\_\_\_\_

City/State/Zip \_\_\_\_\_

## AMP-LETTER

All new publication, new owner K8KXK.

The AMP-LETTER is devoted to the design, building, and modification of amplifiers.

The AMP-LETTER will help you lower your building cost, provide sources for parts and information, keep you abreast of latest techniques and solid state design.

Subscription cost \$18.00/yr. 12 issues. Sample issue \$2.00 VISA/Master Charge.

THE AMP-LETTER  
73 Maple Drive, Hudson, OH 44236 216-653-8157



sample issue  
only \$2.50  
PPD

OUR 15TH YEAR!

## AMATEUR TELEVISION MAGAZINE

"FOR THE SPECIALIZED COMMUNICATION RADIO AMATEUR"

	Surface U.S./Canada	Surface All Mexico Foreign	Airmail Central S. America	Airmail All Other Foreign
1/2 year	\$ 10.00	\$ 13.00	\$ 20.00	\$ 23.00
1 year	\$ 20.00	\$ 26.00	\$ 40.00	\$ 46.00
2 year	\$ 38.00	\$ 50.00	\$ 78.00	\$ 90.00
3 year	\$ 56.00	\$ 74.00	\$116.00	\$134.00

ATV-SSTV-FAX-RTTY-Satellites-EME  
Microwave and Computers.

Published 12 times per year by Mike Stone WB9QCD  
P.O. Box H, Lowden, Iowa 52255 0408

less. I designed the time-out circuit to trigger from the window pulses generated by U10 so the circuit will work with all squelch configurations.

Transmit/receive relay K2 connects the telephone line to the transceiver microphone input when picked up. K2 is energized by U11 through Q9. CR9 prevents K2 from being energized when the patch is idle.

## identifier

The identifier in **fig. 4** is a diode-programmable circuit based on a design by K2OAW.<sup>1</sup> Operation has been described adequately in the reference, so I will only cover changes to the original.

The two TTL oscillators of the original were replaced by 555 timers at U14 and at U3 (**fig. 3**), each wired as a minimum-component astable multivibrator. This eliminates start-up problems sometimes experienced with TTL R-C oscillators. R38 controls the ID sending rate and a value of 47K sets the maximum permissible rate of twenty words per minute.

Diode programming of the ID sequence is straightforward. Begin at pin 1 of U20 and connect diodes to the blank or dot lines. No diode and no pin connection produces a dash. DE followed by my call sign is shown as an example.

The 1N34 diodes in both schematics must remain germanium types for a low forward-voltage drop. Silicon diodes have a higher forward voltage and the logic zero level may be too high for proper operation.

U3 in **fig. 3** generates a 1.5 kHz square wave when the KEYING line is high. Increasing R8 will reduce the frequency. The IC-230 microphone input circuitry filters out the square wave harmonics so the tone

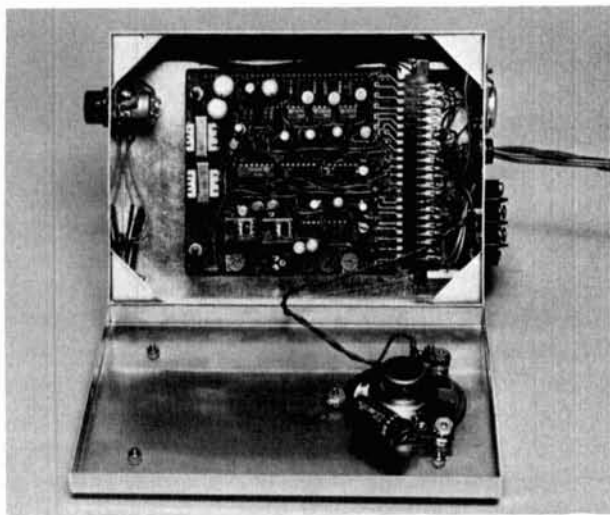

fig. 5. Inside view of the controller chassis. The top circuit board contains almost all of the circuitry of **fig. 3** and mounts by standoffs. Second board is hidden.

sounds like a sine wave. With a transceiver other than the IC-230, check if the ID is audible 15 kHz or more from the carrier center frequency. If audible, add a low-pass filter at the output of U3 or replace the circuit with a sine wave oscillator.

## reset circuitry and power supply

U17 in **fig. 4** generates a power-on reset for the entire control circuit. The manual reset is a push-button mounted on the controller back panel. The initial state of counter U18 and all flip-flops except the divide-by-two circuit of U15 is reset by U17 and U16B.

Power supply input is in parallel with the transceiver 12 Vdc supply and the autopatch controller adds one-half Ampere to this source. Fuse ratings should be set accordingly. U13 provides regulated +5 Vdc for the TTL and timer circuitry.

## construction

The control circuit was built on two separate plug-in boards secured with spacers. I used Radio Shack 276-154 and 276-157 boards with 44-pin edge connectors (276-1551). The monitor speaker is mounted on the detachable bottom plate.

The chassis front panel holds the on-off switch (S2), monitor volume control (R5), in-use indicator DS1, and power indicator DS2.

**Fig. 6** shows the chassis rear panel with regulator U13, manual reset push button switch S1, and the telephone interface terminal strip. Transmit and receive audio lines are brought through the grommet and should be shielded cable.

TTL devices may be 74LS types. Two 555 timers may be replaced by a single 556 dual timer with appropriate pin connection changes. All diodes except CR10 and CR7 must be germanium types to avoid exceeding the 0.8 volt logic zero level.

## the transceiver

Although my system uses a slightly modified IC-230, other transceivers should work as well if they can shift rapidly between transmit to receive and back to transmit. The rapid change is a requirement of the receive window. This requirement unfortunately excludes many synthesized-frequency units; the synthesizer voltage-controlled oscillator cannot shift transmit and receive frequencies rapidly. The IC-230 is frequency-synthesized but uses fixed-frequency oscillators for the 10.7 MHz first i-f offset.

The IC-230 allows an acceptably-short receive window with no modifications to the solid-state transmit/receive switch. Some autopatch controllers require modification of this switch so that the receiver

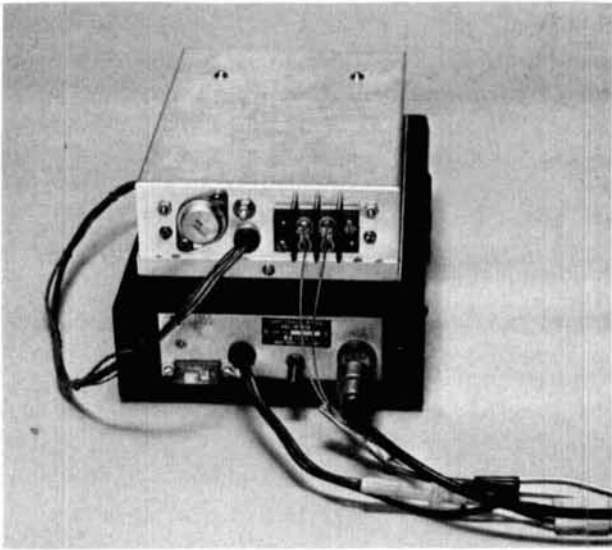

fig. 6. Rear view of the system. The back panel of the chassis contains regulator U13, the manual reset push button, and a terminal strip for the telephone line. The speaker of the IC-230 is disabled by a dummy plug in the external speaker jack to eliminate squelch action noise. The slide switch added to the IC-230 is a modification not needed for the autopatch.

is always on. This makes the rig unsuitable for normal transceiver use: audio feedback occurs during transmit.

One shortcoming of nearly every transceiver is a slow squelch. Fig. 7(A) shows the squelch switching circuit in the IC-230, similar to those in other transceivers. Rectified noise enters the base of Q7 to force the collector low, turning off subsequent audio stages and quieting the speaker. Squelch action is slow because C18, C20, and C23 must either charge or discharge each time the squelch changes state. Reducing their values to those in parentheses will speed squelch action considerably.

C21 is an additional low-pass filter element for power to the receiver audio section. Reducing its value will allow the receiver to turn on faster during the controller receive window.

The AF module on the IC-230 chassis bottom contains these capacitors and may be located with the aid of fig. 7(B). In exchange for greater controller complexity, the squelch modification may be avoided altogether by building a separate fast-acting squelch within the controller.

The remaining transceiver modification is that of bringing out the signals needed by the controller. The IC-230 accessory socket provides three of these in addition to ground and +12 Vdc. The squelch switch is the only signal not factory-wired to the socket shown in fig. 7(C). ICOM does provide a con-

ductor pin on the AF module, as pointed out in fig. 8. A wire from this point will replace the existing accessory socket pin 1 wire and complete the controller interface.

For transceivers without an accessory socket, the microphone input and push-to-talk connections can be made at the microphone connector. Occasionally test pins are provided for discriminator and squelch switch outputs.

## primary power and antenna

It may be prudent to use a high-capacity battery in place of the usual line-powered dc supply. It could be on a constant trickle charge and would allow operation during power outages. My system is powered by a 20 Ampere-hour Globe Gel/Cell® and is capable of eight hours continuous transmit after commercial power failure.

In most cases the antenna system should be omnidirectional with as much gain as possible. Remember

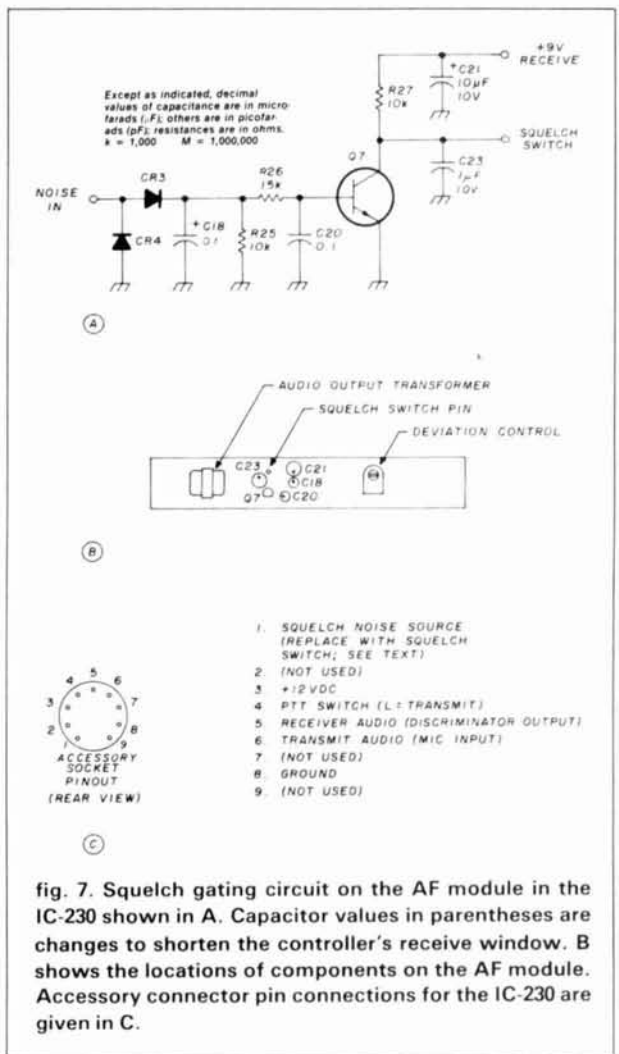

fig. 7. Squelch gating circuit on the AF module in the IC-230 shown in A. Capacitor values in parentheses are changes to shorten the controller's receive window. B shows the locations of components on the AF module. Accessory connector pin connections for the IC-230 are given in C.

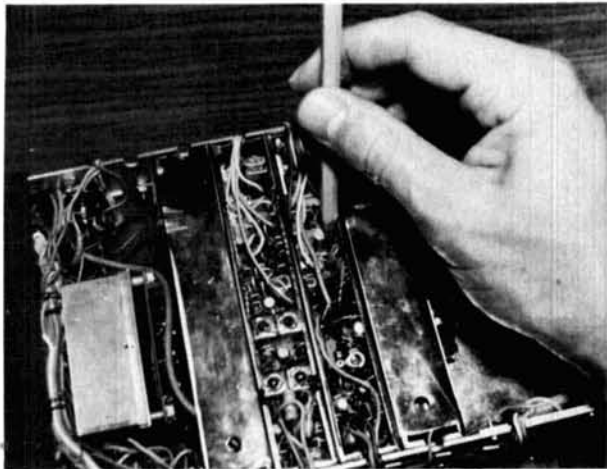

fig. 8. The pencil tip points to the squelch switch pin on the AF module underneath the transceiver.

that the type and location of the antenna is extremely influential toward ultimate coverage area of the autopatch.

### control circuit alignment

The only alignment required is the adjustment of nine trimmer potentiometers. R30 and R31 control the receive window, R2 adjusts receiver output into the telephone line, and R4 sets the telephone line level into the transmitter. R18 controls the tone decoder input level while R15, R20, and R24 adjust the individual decoder center frequencies. Decoder frequency stability is dependent on the type of capacitors used for C15, C19, and C22; polystyrene or metal-film types are recommended. R7 sets the ID tone volume.

R2 is set high enough to activate the telephone company's tone-dialing circuitry. R18 is then adjusted for about 100 millivolts audio on pin 3 of each decoder.

An accurate audio generator is handy for aligning the decoders. Lacking this, you can generate the proper tones by the two-button technique on your tone pad. Pressing both \* and # produces 941 Hz, \* and 7 gives 1209 Hz, while # and 9 will generate 1477 Hz.

### operation

Mobile operation is quite convenient. Transmit your call first, then send a # tone. The autopatch will ID as soon as your carrier disappears, then send a dial tone (from the telephone connection) interrupted by the periodic receive window. Wait about a second after initiating your carrier to ensure the system has switched to receive, then send the desired telephone number.

When the conversation is completed (remember the 10-minute limit), send a \* to disconnect the patch. Sending a # in place of the \* will initiate another call. In either case, the system will ID again when your carrier drops. Should the patch remain on for about two minutes with no received signals, it will time-out and return to standby mode.

Both sides of a conversation may be monitored through the speaker at the autopatch fixed location. Pushing the reset button will return the system to standby. The transceiver may be operated normally by turning off the controller.

Although the system is called a simplex autopatch, it will work as well on an unused repeater channel. This has an advantage of increased privacy since each side of the conversation is on a different frequency.

### conclusion

The purpose of this control circuit is to permit a simple, inexpensive, easy-to-construct method for taking advantage of the ability to make telephone calls from mobile or portable transceivers. The system lacks security since anyone who knows or guesses the simple access code can make telephone calls. Three general security methods have been used with autopatches: a complex access code, providing zero and one first-digit lockout, or adding sub-audible encoding.<sup>2</sup> Anyone with a tape recorder and some patience can decipher a long access code, so this method is not very secure.

Although requiring more gating and tone decoder circuitry, the zero-one lockout method may be best if the autopatch is to be an open system. Subaudible tone access will provide increased security by limiting patch access.

This autopatch has been in use for several months and I have not experienced problems with it. If you have any suggestions for improving the system, please let me know.

### references

1. Peter A. Stark, K2OAW, "A TTL Logic CW ID Generator," *73 Magazine*, February and March, 1973.
2. *The Practical Handbook of Amateur Radio FM and Repeaters*, Bill Pasternak, WA6ITF, with Mike Morris, WA6ILO, TAB Books Inc., 1981.

### bibliography

- IC Timer Cookbook*, Walter G. Jung, Howard W. Sams, Inc., 1977.  
 ICOM IC-230 VHF fm Transceiver schematic.  
*Semiconductor Reference Guide*, Radio Shack Inc., 1981.  
 Signetics Data Manual, 1976.  
 Signetics NE555 Timer Specification Sheet, 1972.

## INCREDIBLE CODE!!

Learn the International Morse Code  
by the patented  
"WORD METHOD"

**NO** BOOKS  
CARDS  
VISUAL AIDS  
GIMMICKS

Just listen and learn! The "WORD METHOD" is based on the latest scientific and psychological techniques. You can zoom past 13 WPM in less than HALF THE USUAL TIME!!

The kit contains two cassette tapes, over TWO HOURS of unique instruction by internationally famed educator Russ Farnsworth. Complete satisfaction guaranteed.

Available at local Electronic Dealers, or send check or money order for \$14.95 plus \$1.50 for postage and handling to:

### EPSILON RECORDS

5002 W. McFadden - #73  
Santa Ana, Ca. 92704

continued from page 8

on to oppose a no-code license. Several ARRL directors have told me privately that they favor such a license but must oppose it because the members they represent are against it. The same is no doubt true of some ARRL staff members.

Japan, Sweden, and England, among others, have had a no-code license for years and the sky has not fallen. Seventeen other countries require only code "recognition," not reception, for licenses. A number of these licensees go on to learn the code, upgrade their licenses, and use additional modes and frequencies.

The FCC deserves the respect and thanks of thoughtful Amateurs for pursuing this issue in an effort to strengthen the Amateur service and help to ensure its usefulness and its future. — Stuart D. Cowan, W2LX, KM2XDU.

I am astounded, amazed, and dismayed at your September, 1982, editorial position on the code-free license. Your remark that the time has come to discard the "what's good enough for grandpappy is good enough for you" mentality is indicative of your complete lack of understanding of Amateur Radio today and as of yesterday.

Gentlemen, Amateur Radio is not simply another hobby. The creation of a no-code license would be contrary to one of the fundamental traditions of Amateur Radio. Whether or not the prospective licensee plans to operate his station on CW, RTTY, computer, or telephone is unimportant. Learning the code, in the beginning of his interest in Amateur Radio, introduces him to an activity steeped in many traditions; and, to the requirement that such activity be in the public interest, convenience and necessity. The code requirement is the first thing that separates the licensed Radio Amateur from the unlicensed tinkerer and the CB operator, licensed or unlicensed.

Many of us, the writer included, began a professional career in communications via the Amateur Radio

route. Even as a teenager we appreciated the importance of our earned entry into the world of Amateur Radio. We became part of a highly special, unique group, with associations of tremendous importance in our chosen career, associations never to be forgotten. — Byron H. Kretzman, W2JTP.

I seriously question your reasons for endorsing a no-code license. We don't need a "larger and faster growing" Amateur population of the quality we have already seen after the recent CB craze. The existing exams are lenient enough, not to mention the multiple choice CW part! To me, anyone who cannot pass a multiple choice CW "test" of 5 WPM is not capable or deserving of being called a ham. When other modes of communication have failed, CW has been used. I would hate to hear about a situation where a ham would not be able to respond to or initiate an emergency message on CW.

The bottom line is your bottom line in your next to last paragraph: "Consider just how such a license could be incorporated into our Amateur structure without cheapening what we've got." — Alan J. Blank, W1BL.

I want to take this opportunity to congratulate you and Joe Schroeder for your joint editorial that appeared in the September, 1982, issue. It was high time that someone told it as it is. I also hold an Extra, have a 30 WPM CP, and still use my old Vibroplex — but, I have a computer and a fairly well equipped small lab, so I don't think I have "given up" trying to stay with the state-of-the-art.

Also, I constantly argue that the FCC test should be slanted more toward R&R, operating procedures, etc., and only the minimum technical questions relating to determining if a transmitter is operating properly. As a graduate E.E., I think some of the questions presently used are slanted toward the hiring exam for an electronics technician, not a ham operator! — John P. Weber, Jr., K4JW.

**A GREAT GIFT IDEA**

**PERSONALIZED AMATEUR RADIO WINDOW DECALS**

AMATEUR RADIO  
UR CALL

**Beautiful — Durable**

These personalized decals will adhere to the inside of windows —

cars	home
shack	boat
office	anywhere . . .

**\$5.00 - 1    \$9.00 - 2    \$12.00 - 3**

Send check or money order with Ham Call, name and address to:

**DELRAFT CO.**  
PO Box 148, Westland, MI 48185  
Clubs and organizations please write or call 313-425-0009 for special pricing

### QUALITY MICROWAVE TV SYSTEMS

#### 1.9 to 2.5 GHz Antennas

Complete System (Rod Style as pictured)	\$124.95
Complete System (Reflector Style as pictured)	\$149.95
Down Converter, Assembled & Tested	\$64.95
Power Supply (12 to 18V)	\$49.95

Also Dish Style Antennas In Stock.

**Galaxy Electronics**  
6007 N. 61st Ave.  
Glendale, Az.  
85301  
(602) 247-1151

COD's  
Quantity Pricing

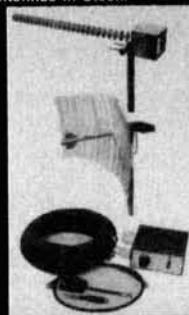

90 DAY WARRANTY  
PARTS & LABOR





**COAXIAL DIPOLE HJ-SERIES - FOR THE SHORTWAVE LISTENER AND HAM OPERATOR**  
(MADE FOR ANY FREQUENCY BETWEEN 1.7 MHZ AND 148.0 MHZ)

- \* CAN BE PHASED WITH PHASING KIT (HJ-PHASING KIT)
- \* WITHSTANDS EXTREME WEATHER CONDITIONS (-60°F to +150°F)
- \* ONLY ONE MAIN SUPPORT NEEDED

- \* ANTENNA IS MADE OF FLEXIBLE CABLE
- \* A GREAT FIXED OR PORTABLE ANTENNA
- \* EASY TO STORE
- \* RUGGED

- \* LOW S.W.R.
- \* HANDLES 2KW DC +
- \* WELL BUILT
- \* INEXPENSIVE PRICES START AT \$45.00

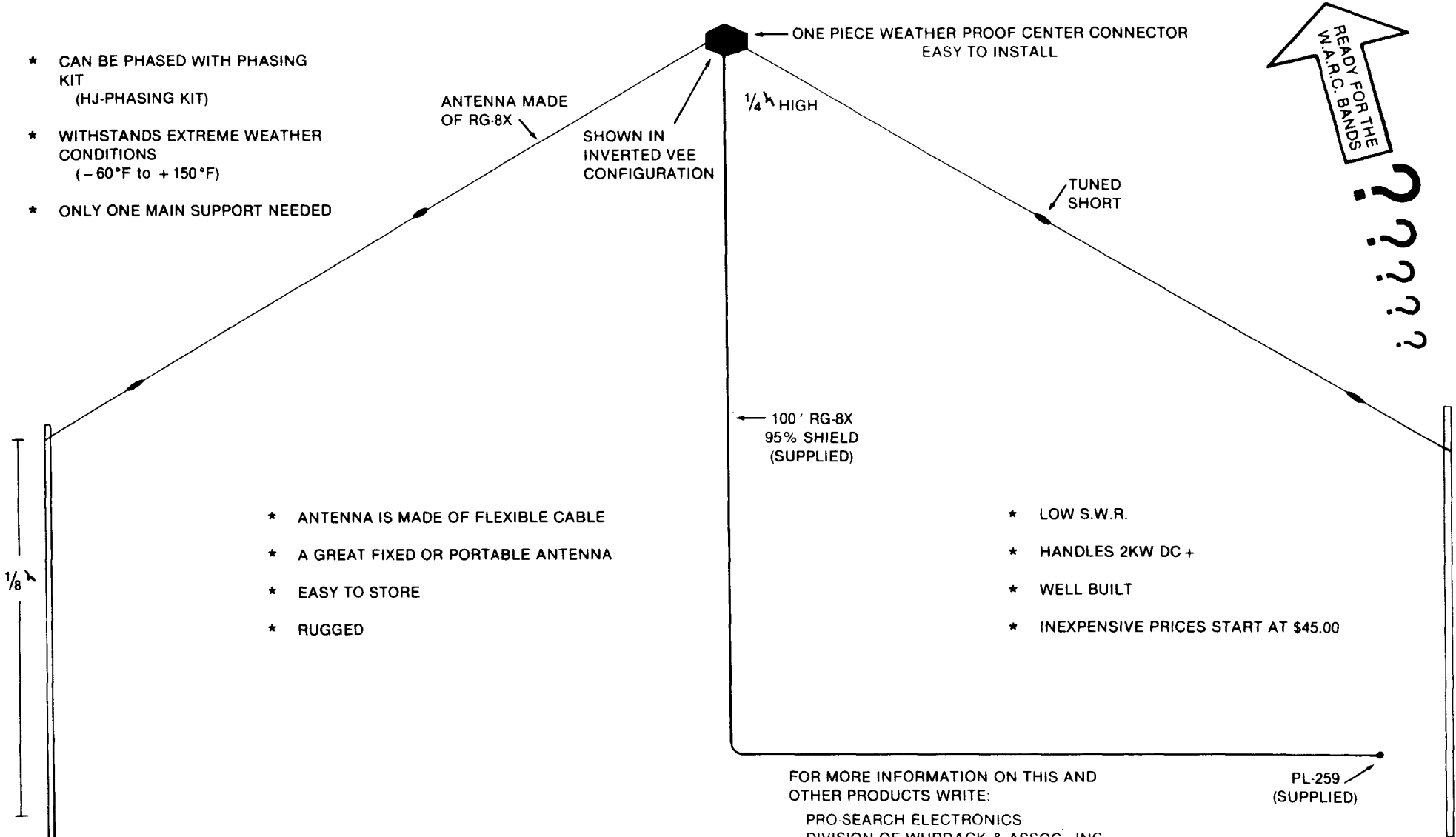

FOR MORE INFORMATION ON THIS AND OTHER PRODUCTS WRITE:

PRO-SEARCH ELECTRONICS  
DIVISION OF WURDACK & ASSOC., INC.  
10411 CLAYTON RD. SUITE 305  
ST. LOUIS, MO. 63131. USA  
314-994-7872

PL-259 (SUPPLIED)

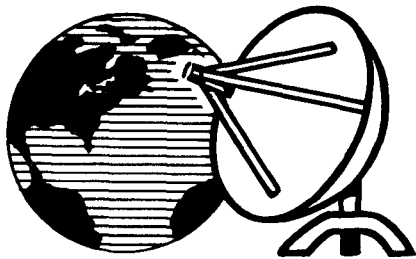

## SATELLITE TELEVISION SYSTEMS

**WE WILL NOT BE UNDERSOLD!!**

**Complete Systems, Antennas, Receivers, LNA's & Accessories**

**CALL US TODAY!**

**812-238-1456**

**hoosier electronics**

*"Nation's Largest Total Communications Distributor"*

P.O. BOX 3300 • TERRE HAUTE, INDIANA 47803

# Do You Know This Person?



This person is a leader in the community, at home, at work, and in Ham Radio. They could be a Brass Pounder, a dyed-in-the-wool phone man, an avid DXer, a staunch VHF'er or maybe he or she is lurking in your household, posing as a husband, wife, father, brother, sister, or even your next door neighbor or someone just down the block. This shadowy unknown person is sought to join an impressive group of formerly unrecognized hams including such notables as Ed Tilton, W1HDQ and Senator Barry Goldwater, K7UGA.

Have you guessed who we're searching for? Right... It's the "Ham of the Year" to be honored at the Dayton Hamvention on April 30, 1983. If you know this person, why not grab a pen and turn him or her in for a great reward. Get all the facts — fully detailed — and send in your nomination NOW. This award is not for one-time achievement, but for continued all-around outstanding performance and contribution to civic and Ham activities.

There is a separate award for one-time special achievements including DX-peditions, emergency work, or excellence in some technical area of Ham Radio. So if you feel you know some worthy Ham who should be recognized for his work, why not give him a chance and send in a nomination now to the Dayton Hamvention. There are many amateurs in our ranks deserving our recognition. All that's needed is someone to nominate them. Who knows, you may have a winner in your own backyard... Hurry... deadline for all nominations is April 1, 1983. ALL NOMINATIONS AND CORRESPONDENCE FOR FURTHER INFORMATION SHOULD BE SENT TO:

**Dayton Hamvention**

ATTN: AWARDS CHAIRMAN

P.O. BOX 44, DAYTON, OHIO 45401

## Computer Program Books for Beginners

Everything you need to know to get started programming your own computer. These handy books of programs, each jam-packed with easy-to-understand info for beginners, are crammed with hundreds of tips, tricks, secrets, hints, shortcuts, techniques, plus hundreds of tested ready-to-run programs. For the TRS-80 Color Computer. For the TRS-80 Pocket Computer and Sharp PC-1211, PC-1500 pocket computers.

### Color Computer

**101 Color Computer Programming Tips & Tricks**, learn-by-doing instructions, hints, secrets, shortcuts, techniques, insights, for TRS-80 Color Computer, 128 pages **\$7.95**

**55 Color Computer Programs for Home, School & Office**, practical ready-to-run software with colorful graphics for TRS-80 Color Computer, 128 pages. **\$9.95**

**55 MORE Color Computer Programs for Home, School & Office**, sourcebook of useful type-in-and-run software with exciting graphics, for TRS-80 Color Computer, 112 pages. **\$9.95**

### Pocket Computer

**Pocket Computer Programming Made Easy**, new fast 'n easy way to learn BASIC, make your computer work for you, for TRS-80, Sharp, Casio pocket computers, 128 pages. **\$8.95**

**101 Pocket Computer Programming Tips & Tricks**, secrets, hints, shortcuts, techniques from a master programmer, 128 pages. **\$7.95**

**50 Programs in BASIC for Home, School & Office**, sourcebook of tested ready-to-type-in-and-run software for TRS-80 and Sharp pocket computers, 96 pages. **\$9.95**

**50 MORE Programs in BASIC for Home, School & Office**, ideal source for lots more useful software for TRS-80 and Sharp pocket computers, 96 pages. **\$9.95**

QTY.	Title	Price	Total

Allow 2-4 weeks for delivery.

SHIPPING **\$2.00**

TOTAL

### FROM:

Name \_\_\_\_\_ Call \_\_\_\_\_

Address \_\_\_\_\_

City \_\_\_\_\_ State \_\_\_\_\_ Zip \_\_\_\_\_

Check or Money Order Enclosed

VISA

MasterCard

Acct. # \_\_\_\_\_

Expires \_\_\_\_\_ MC Bank # \_\_\_\_\_

**SEND TO: HAM RADIO'S BOOKSTORE  
GREENVILLE, NH 03048**

# logic mate

## A simple, convenient IC trouble-shooting aid

**The Logic Mate (LM) is an IC trouble-shooting aid** that combines the features of a logic monitor and IC tester in a single, compact unit. Inserted between an IC and its circuit socket, it allows pin connection switching, displays pin voltages, and provides output loading. Power is obtained from the main circuit socket and ranges from 5 to 15 volts.

The LM works with all saturating-logic families such as TTL, CMOS, DTL, ECL, plus many linear ICs. U1 pin voltage swings may not be enough with ECL or linear ICs, but all disconnect and forcing inputs operate properly.

### about the circuit

Fig. 1 shows the schematic for one of two identical boards in the LM. The plug/header pins connect to the circuit under test while the test socket holds the IC. Pin numbers are indicated for one side of a sixteen-pin dual in-line package (DIP); pin numbers in parentheses indicate the other side.

Two eight-pole, single-throw DIP switches are on the plug/header end. S1 is labelled DISC and allows an individual pin to be disconnected and isolated from the main circuit. S2 is labelled 1-0 and grounds the IC pin under test for a logic 0; resistors R9 through R16 provide a pull-up for logic 1 with any S2 open.

A light-emitting diode (LED) array provides displays of each IC pin under all supply voltage conditions. One DS8654 octal display driver is used for

eight LEDs. Individual current limiting for each LED is provided by R1 through R8 and overall current regulation is provided by Q1, CR1, and R17. Without overall regulation, the LED intensity would be too low at 5 volts if the series resistors were selected for 15 volt supplies. Alternately, a correct current at a 5 volt supply would cause too much current at 15 volts and LED life would be reduced.

Individual LEDs need 8 to 12 mA for decent intensity. An LED will drop a relatively constant voltage when conducting. A series resistor selected for 10 mA at a 5 volt supply would cause about a 25 mA LED current at 15 volts.

CR1 is cut off at a 5 volt supply but Q1 conducts via base current through R17 for the LED common cathode return. At higher supply voltages, CR1 conducts and the base of Q1 tracks the increase in voltage. Emitter potential follows base potential for a relatively constant return, or sink current for the LEDs. The emitter return connection provides a low-impedance sink to prevent interaction between different combinations of indicating LEDs.

The octal display driver was designed for a common-cathode display and can source up to 50 mA on each output. The DS8654 will operate in a 4.5 to 33 volt supply range, conservative for this design. Supply voltage is obtained from the main circuit on pin 16 and alternate means are explained later.

### construction

Two boards are required. You can etch your own or purchase a pair of etched boards with plated-through holes. If you etch your own, you must solder R9-R16 and U1 pins 1 through 9, and pin 14 on both sides of the board. Boards without plated-through holes also require through-board jumpers as indicated in fig. 2.

By Paul Selwa, N9CZK, 61 East Tilden Drive, Brownsburg, Indiana 46112

Figs. 2 and 3 indicate R1 to R8 and R9 to R16 as single-inline packages (SIP). SIP resistor packs can be replaced by individual quarter-watt resistors mounted on end. The common connection above the board is made to each SIP end pad; the ninth resistor in each SIP pack is unused and shorted as indicated by the dashed lines in fig. 1. Each SIP pack may be mounted in either direction.

The etch pattern and purchased boards allow for three types of LED arrays. The AMP array indicated in the parts list is in DIP form with 0.3-inch pin row spacing. The anode is marked with an A and a dot is at pin 1. The Litronix array has a 0.1-inch row spacing and cathodes are marked with a cross bar. Individual Dialight LEDs mount side-by-side on 0.2-inch spacing. All LEDs must have the anode pins adjacent to U1.

Each board must be jumpered to match the plug/header and test socket pin row. Jumper G must be installed for the board with pins 1 through 8. Ground is obtained from plug pin 8. The board for pins 9 to 16 should have jumper V installed.

Note that jumper V goes directly to S2-8. The reason is two-fold: you cannot accidentally ground the main circuit supply at pin 16, and that pin may be iso-

lated if the supply is not at that pin. The occasional need to ground pin 16 may be accomplished with a clip lead.

Probing points for the main circuit plug/header end are wires soldered on the foil side. I recommend

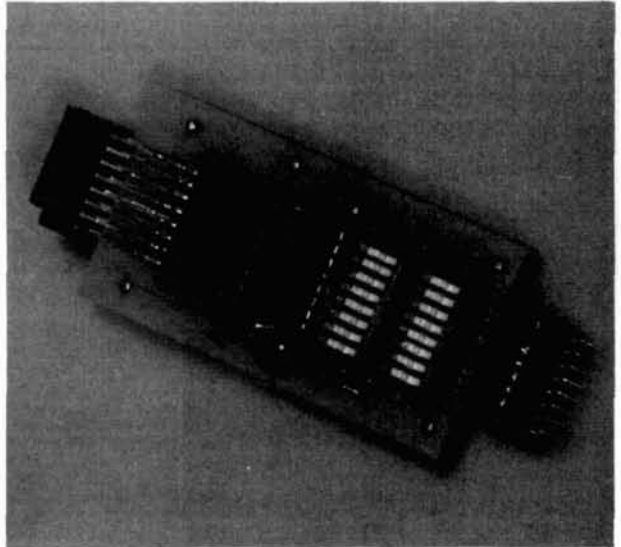

Top view of one of two completed boards.

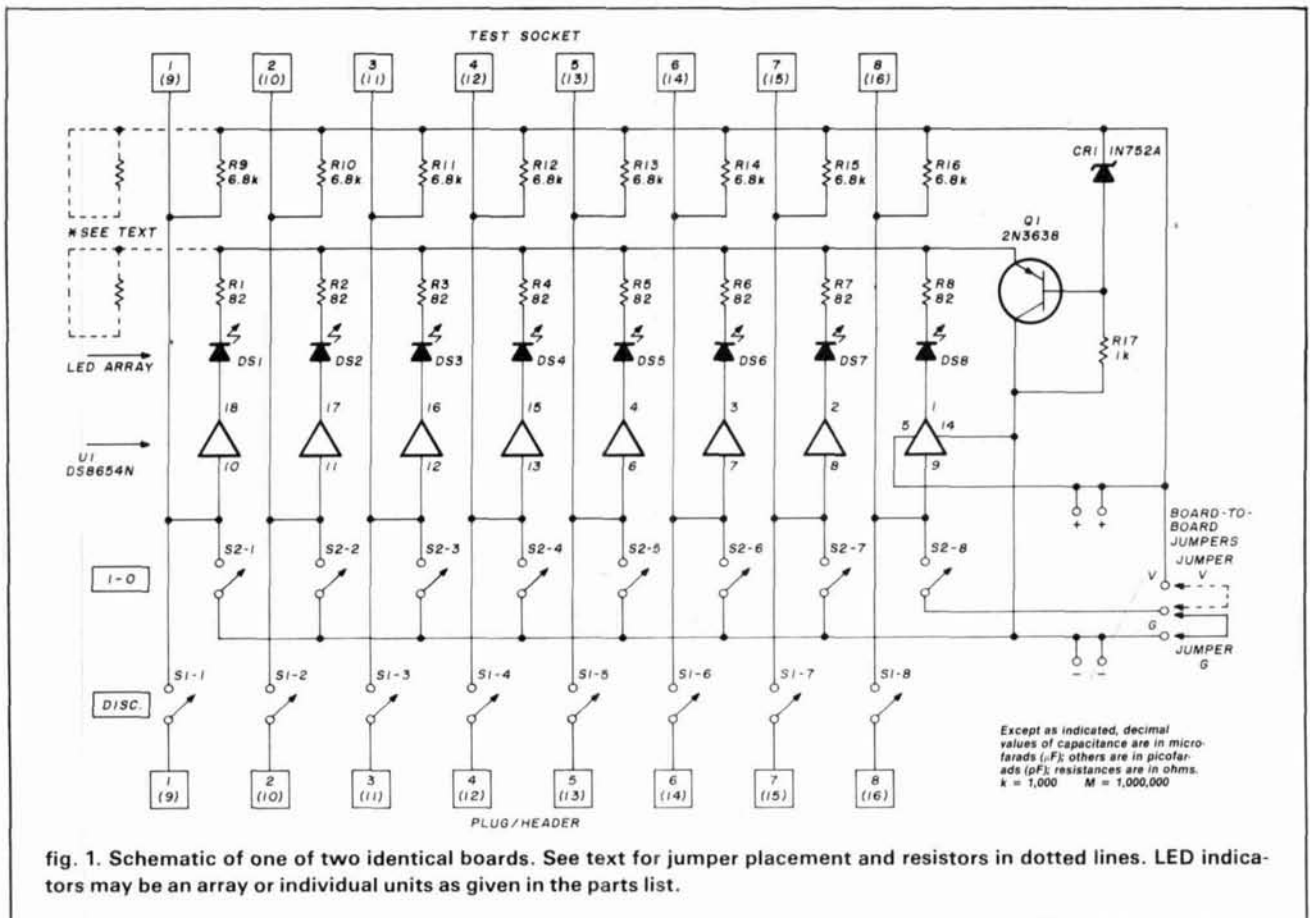

fig. 1. Schematic of one of two identical boards. See text for jumper placement and resistors in dotted lines. LED indicators may be an array or individual units as given in the parts list.

using wire-wrap pins for stiffness and this applies to inter-board jumpers in the final assembly.

### final assembly

Both boards are mounted foil-side with both boards inside the header pin rows. I would suggest final assembly in the order following: First, solder two header pins to one board with connecting wires passing through the split in each pin. Take care that header and board connections line up.

Second, insert four board-to-board jumper wires at the pads marked + and - in fig. 3 and solder them to the first board. Make them perpendicular to the board and long enough to pass through the pads of the second board.

Third, place the second board so the header end is inside the header pins and the board-to-board jumpers pass through the same + and - pads. Recheck alignment and avoid shorts between boards. Solder the board-to-board jumpers when satisfied.

The final step is to solder the test socket to the board. Leave enough socket tail outside the board for probe points. Stiff board-to-board jumpers provide enough support strength for both boards. Additional support is gained with two more jumpers at the unconnected X pads.

A socket on the plug/header will protect the pins between tests. Another option is a zero insertion-force socket for the test socket.

### operation

The LM plug/header pin 16 should mate with main circuit socket pin 16 for the positive supply voltage (pin 14 on most 14-pin DIPs). Ground connection is made by closing both S1 and S2 for the ground pin. Pin 8 is the usual ground for a 16-pin DIP, pin 7 for a 14-pin DIP. Remaining pins are controlled by S1 for disconnect or S2 for logic 1 or 0.

For non-standard power and ground connections, a pin ground is always obtained by closing both S1 and S2. The supply pin should have S1 closed and S2 open with the supply voltage clipped to the + board-to-board jumpers. Pin 16 must have its S2 open for a non-standard supply pin; pin 16 may have a main circuit driver and closing that S2 to the supply can destroy that part of the main circuit. Closing S2 of any pin connected to the main circuit supply would yield an unscheduled test of the power supply current limiter!

This description has assumed a positive voltage for the supply with a ground for the return. The LM will also work with negative voltages: consider the LM's + line as the most-positive potential of the main circuit and the - line of the LM as the most-negative. (A negative main circuit supply would require reversal of the V and G jumpers. — Editor's note.)

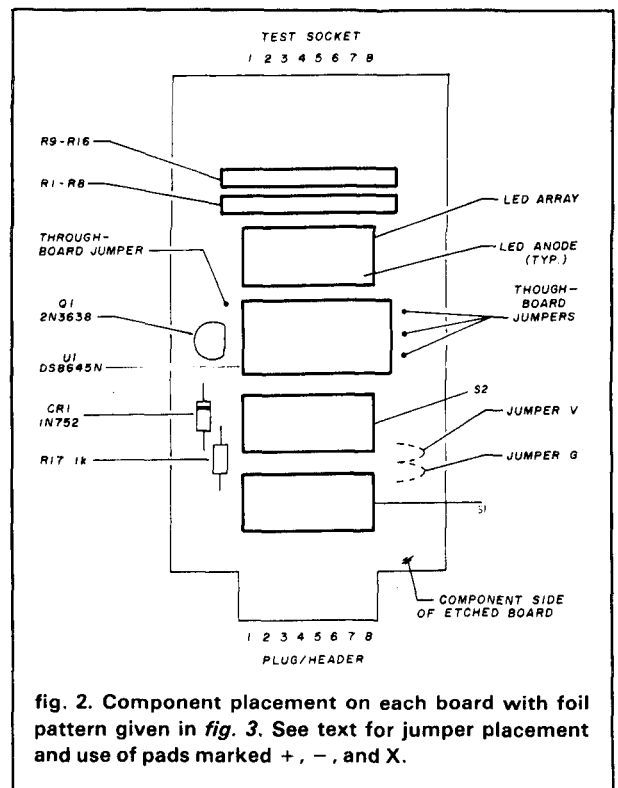

fig. 2. Component placement on each board with foil pattern given in fig. 3. See text for jumper placement and use of pads marked +, -, and X.

### Parts List for One Board of the Logic Mate

CR1	1N752A zener diode
DS1 to DS8	Choice of: (1) AMP Inc. 435733-7 (1) Litronix LD468 (8) Dialight 555-3003
Q1	2N3638 PNP transistor
R1 to R8	82 ohm, 10-pin SIP resistor pack, Bourns 4310R-101-820 or equivalent
R9 to R16	6800 ohm, 10-pin SIP resistor pack, Bourns 4310R-101-682 or equivalent
R17	1000 ohm, 1/4 Watt, 5 percent resistor
S1,S2	Eight-position DIP switch
U1	National Semiconductor DS8654N octal display driver
Test Socket	Aries A221 or equivalent (wire-wrap tails)
Plug/Header	Aries A103 or equivalent

### some examples of operation

One way to isolate a suspect IC pin is to bend it out of contact. This can damage the IC connection even if the IC was good before bending. A better way is to insert the LM and use the appropriate S1 disconnect switch to isolate the pin. The pin is not damaged and the built-in pull-up resistor allows checking of open-collector outputs.

The LM is a logic state monitor if all S1 disconnect switches are closed and all S2 switches opened. The

**Tri-Ex TOWER CORPORATION**  
**TRI-EX TOWER — THE TOWER OF YOUR FUTURE**

Tri-Ex is the tower of your future. If you want quality and experience, Tri-Ex is the name you want. People from all over the world recognize Tri-Ex and that is why Tri-Ex is located on every continent of the globe. Tri-Ex towers are manufactured in the United States and licensed for manufacture in Europe.

Tri-Ex puts the same quality in each and every tower. Ask those who own them. Features include high strength low wind resistant W bracing formed guides, galvanizing inside and out, high strength aircraft cabling, hand and motor driven winch systems, bearing, rollers, and electronic welding in precision cut.

Tri-Ex manufactures a complete line of towers, crank-up towers from 25 feet to 150 feet, and stacked towers from 10 feet up.

For additional information write to:  
**TRI-EX TOWER CORPORATION**  
 P. O. Box 5009  
 Visalia, CA 93278  
 209-651-2121

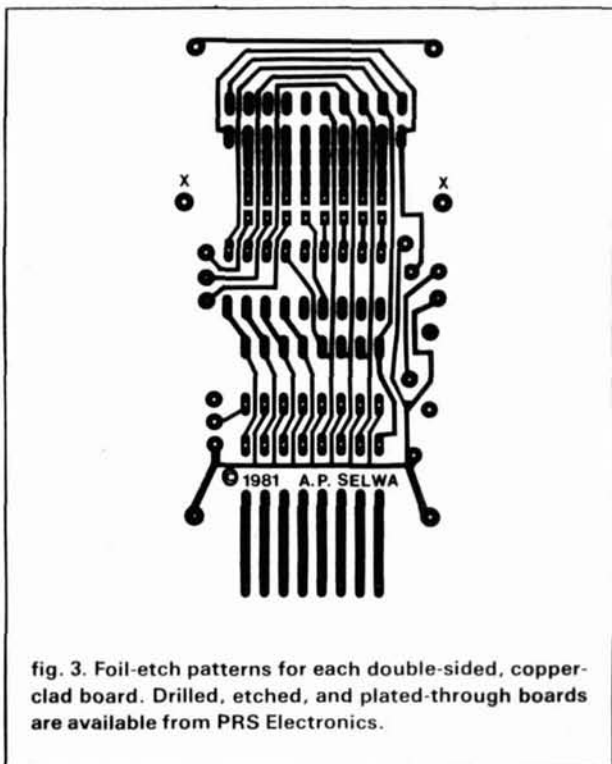

fig. 3. Foil-etch patterns for each double-sided, copper-clad board. Drilled, etched, and plated-through boards are available from PRS Electronics.

IC under test will operate the same as if plugged into the main circuit.

The LM can be an IC tester, isolated from the main circuit. Simply open all S1 switches except for power and ground and plug the LM into any convenient socket. The S2 1-0 switches allow control of all IC inputs.

Linear circuits can be checked by isolating pins with the disconnect switches. Pull-up resistors can provide loads and you can connect clip leads to the test socket probe points. Please note that a linear IC output may or may not indicate the same as a digital device: Voltage swing may be insufficient for the input of driver U1.

### where to get parts

Etched, drilled, and plated-through circuit boards are available for \$8.00 a pair from:

PRS Electronics  
 P. O. Box 274  
 Brownsburg, Indiana 46112.  
*(Indiana residents add 4% tax.)*

The AMP LED array, Litronix LED array and the DS8654 are available COD from:

Advent Electronics, Inc.  
 Dept. 7  
 8446 Moller Road  
 Indianapolis, Indiana 46268.

**WARNING!**  
 Electric Power Pollution.  
 Spikes & Lightning  
**HAZARDOUS to**  
**MICROCOMPUTERS!!**

Patented ISOLATORS provide protection from . . .

- Computer errors cause by power line interference
- Computer errors due to system equipment interaction
- Spike damage caused by copier/elevator/air conditioners
- Lightning caused damage

**MONEY BACK GUARANTEE!**

- ISOLATOR (ISO-1) 3 isolated 3-prong sockets; Spike Suppression; useful for small offices, laboratories, classrooms. . . . . \$69.95
- ISOLATOR (ISO-2) 2 isolated 3-prong socket banks; (6 sockets total); Spike Suppression; useful for multiple equipment installations. . . . . \$69.95
- SUPER ISOLATOR (ISO-3) similar to ISO-1 except double isolation & oversize Spike Suppression; widely used for severe electrical noise situations such as factories or large offices. . . . . \$104.95
- SUPER ISOLATOR (ISO-11) similar to ISO-2 except double isolated socket banks & Oversize Spike Suppression; for the larger system in severe situations. . . . . \$104.95
- MAGNUM ISOLATOR (ISO-17) 4 Quad Isolated Sockets; Multiple Spike Suppressors; For ULTRA-SENSITIVE Systems in extremely Harsh environments. . . . . \$181.95
- CIRCUIT BREAKER, any model (Add-CB) . . . . . Add \$9.00
- REMOTE SWITCH, any model (Add-RS) . . . . . Add \$16.00

AT YOUR DEALERS  
 MasterCard, Visa, American Express

ORDER TOLL FREE 1-800-225-4876 (except AK, HI, PR & Canada)

Pat. #4,259,705

**Electronic Specialists, Inc.**  
 171 South Main Street, Box 389, Natick, Mass. 01760  
 (617) 655-1532

# Barry Electronics Corp.

WE SHIP WORLDWIDE

WORLD WIDE AMATEUR RADIO SINCE 1950

Your one source for all Radio Equipment!

COMMERCIAL RADIOS  
stocked & serviced on  
premises.

We Will Not Be Undersold Call:  
212-925-7000



Wherever I go, I take my Radio!

KITTY SAYS: WE ARE NOW OPEN 7 DAYS A WEEK.

Now open on SUNDAYS  
Saturday & Sunday 10 to 4 PM  
Monday-Friday 9 to 6:30 PM

Come to Barry's for the best buys in town. For  
Orders Only Please Call: 1-800-221-2683.



FT-ONE, FT-980R FT-102, FT-101ZD, FT-707, FT-230R,  
FT-480R, FT-720RU, FT-290R, FRG-7700, FT-625RD

ICOM



IC-R70, IC-720A, IC-730, IC-740, IC-25A,  
IC-251A, IC-2KL, IC-451A, IC-290H, IC-45A

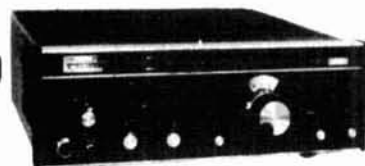

DRAKE TR-5, TR-7A, R-7A, L-7, L-15, Earth  
Satellite Receiver ESR-24, THETA 9000E & 500,  
Digital Multimeter Model #8550-\$95.00

**SUPER SALE ON ROBOT, CALL!**



ROBOT Slow Scan TV 400 & 800

Color Conversion Kit  
for Robot 400 ... \$450

POWER PACKET  
VoCom Power  
Amplifier &  
5/8λ HT Gain  
Antennas IN STOCK

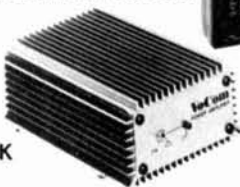

YAESU  
FT-208R  
FT-708R

ICOM  
IC2AT  
IC3AT  
IC4AT

Land-Mobile H/T  
Wilson Mini-Com II  
Yaesu FTC-2203, FT-4703  
Icom IC-M12 (Marine)  
IC-H12



SANTEC  
ST-144/UP  
ST-440/UP

SMART PATCH

CES-Simplex Autopatch 510-SA Will Patch FM  
Transceiver To Your Telephone. Great For  
Telephone Calls From Mobile To Base. Simple  
To Use - \$319.95.

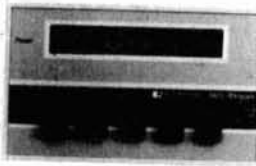

KANTRONICS  
Mini-Reader, Field Day  
Interface, Code Tapes In Stock

BIRD  
Wattmeters &  
Elements  
In Stock



MIRAGE B-23, B-1016, B-108,  
B-3016, C-22, C-106, D-24, D-1010

NEW IMPROVED  
MURCH Model UT2000B

Dentron Amplifiers, Tuners, Receivers Stocked:  
Clipperton T, Clipperton L, GLA-1000B,  
GLT-1000, Galion, MLA-2500 2 Meter 1800  
Watts Linear, MLX Mini Transceiver, The  
Scout C.A.P. Transceiver, Horizon One  
Transceiver, Station One CW Radio Station.  
Write for specs, or call.



EIMAC  
3-500Z  
572B, 6JS6C  
12BY7A &  
4-400A

AEA 144 MHz  
AEA 440 MHz  
ANTENNAS



KDK-2030

BENCHER PADDLES &  
Vibroplex Keys In Stock!!

DIGITAL  
FREQUENCY  
COUNTER

Trionyx-  
Model TR-1000  
0-600 MHz  
Digimax Model D-510 50 Hz-1GHz



Tri-Ex Towers  
Hy-Gain Towers & Antennas,  
and Rotors will be shipped  
direct to you FREE of shipping cost.

New York City's

LARGEST STOCKING HAM DEALER  
COMPLETE REPAIR LAB ON PREMISES

New TEN-TEC  
Corsair In Stock

MAIL ALL ORDERS TO BARRY ELECTRONICS CORP., 512 BROADWAY, NEW YORK CITY, NY 10012.

BARRY INTERNATIONAL TELEX 12-7670  
TOP TRADES GIVEN ON YOUR USED EQUIPMENT  
STORE HOURS: Monday-Friday 9 to 6:30 PM  
(\$1.50 parking across the street)  
Saturday & Sunday 10 to 4 PM (Free Parking)

AUTHORIZED DIST. MCKAY DYMEK FOR  
SHORTWAVE ANTENNAS & RECEIVERS.

IRT/LEX-"Spring St. Station"  
Subways: BMT-"Prince St. Station"  
IND-"F" Train-Bwy. Station"

Bus: Broadway #6 to Spring St.

"Aqui  
Se Habla  
Espanol"

Clearance on our WW II  
surplus inventory on  
Washington's Birthday.

We Stock: AEA, ARRL, Alpha, Ameco, Antenna Specialists, Astatic,  
Astron, B & K, B & W, Bash, Bencher, Bird, Butternut, CDE, CES, Collins,  
Communications Spec. Connectors, Covercraft, Cubic (Swan),  
Cushcraft, Dalwa, Dentron, Digimax, Drake, ETO (Alpha), Elmac, En-  
comm, Henry, Hustler (Newtronics), Hy-Gain, Icom, KLM, Kantronics,  
Larsen, MCM (Daiwa), MFJ, J.W. Miller, Mini-Products, Mirage,  
Newtronics, Nye Viking, Palomar, RF Products, Radio Amateur Callbook,  
Robot, Rockwell Collins, Saxton, Shure, Swan, Telex, Tempo, Ten-Tec,  
Tokyo Hi Power, Trionyx TUBES, W2AU, Waber, Wilson, Yaesu Ham and  
Commercial Radios, Vocom, Vibroplex, Curtis, Tri-Ex, Wacom Duplexers,  
Repeaters, Phelps Dodge, Fanon Intercoms, Scanners, Crystals.

WE NOW STOCK COMMERCIAL COMMUNICATIONS SYSTEMS  
DEALER INQUIRIES INVITED. PHONE IN YOUR ORDER & BE REIMBURSED.

Amateur Radio & Computer Courses Given On Our Premises. Call

Export Orders Shipped Immediately TELEX 12-7670

# forget memory

## Ni-Cd memory myths discharged and facts unveiled

**Ni-Cd memory myths** rank with SWR stories and VHF intermod misunderstandings as the most common misconceptions in Amateur Radio. I've had hams tell me they know all Ni-Cds eventually get a memory problem because "it says so in the GE battery book." Not true!

The half-inch thick General Electric Ni-Cd handbook<sup>1</sup> devotes only three paragraphs to the topic of memory effect. Two paragraphs state and restate that "the memory effect does not manifest itself when the battery is discharged to random depths of discharge or overcharged for random amounts of overcharge time as is typically the case in most applications." That statement should relieve hams, not alarm them.

If your Ni-Cd cell voltage falls to zero quickly when discharging, the problem isn't memory effect. A memorized cell experiences voltage drops early in its discharge cycle, but instead of dropping to zero, it goes to the usual discharge cutoff point of around 1.0 volt. For the remainder of the discharge cycle, the cell still provides power but at an unacceptably low voltage.

Two General Electric engineers presented a scholarly treatise on the memory effect in the IEEE *Spectrum* magazine about five years ago.<sup>2</sup> They told how the effect was discovered in satellite test programs, where the cells received a carefully controlled charge/discharge regimen at a constant temperature for hundreds of cycles. Even then, the effect did not always appear in all types of cells. They concluded that "though sintered plate nickel-cadmium batteries can remember, the conditions necessary are almost never encountered in practice" (emphasis added). Sintered plate batteries are the kind we hams use.

So, if that isn't the problem, why didn't your last Ni-Cd pack last for a thousand charges? There are a

couple of likely causes — cell reversal and sustained overcharge.

Do you stop talking the minute your HT's low battery indicator comes on? If you don't, you may be sending your pack to an early grave. Why? Not all cells in a Ni-Cd pack are identical, nor do they reach complete discharge simultaneously. If one cell goes to full discharge first and you draw a medium-to-heavy load, the good cells attempt to charge the discharged cell in the reverse direction, which can damage it quickly, usually causing it to short. A short can be zapped out of a Ni-Cd, but full cell capacity is seldom restored. The zapped cell is likely to get reverse-charged again the next time the pack charge gets low.

Don't continue to use your rig once the low battery warning is present, or you may kill one or more cells through reverse charge. Also, if you've been trying to prevent the memory effect by frequently discharging the entire pack to zero with a single load, you can see that you're actually doing more harm than good.\*

Now the other problem: can you really overcharge a battery with that little wall charger? Sure! Next time you take your battery off the charger, feel the pack (not the charger). Isn't it warm? Try it for two or three days! (On second thought, don't!) When the battery reaches full charge, and you keep putting current into it, the internal chemical reaction changes. The current from the charger begins to break down the water in the cell into hydrogen and oxygen. Much of it recombines, but even at typical slow-charge rates (about 0.1C), heat and pressure build up. When this happens, the cell's vent opens and it slowly dries out. If you're a typical HT user who uses only a fraction of the battery capacity each day, but charges it for 15 hours each night, you shouldn't be surprised if your batteries require replacing prematurely.

Extended slow-charging also can produce what the General Electric engineers call a sustained overcharge effect.<sup>3</sup> It's a depression of the discharge voltage at some point after a long overcharge, and is quite common. The longer the overcharge, the ear-

By Joe Moell, K0OV, Box 20-GJ, Fullerton, California 92633



## CB TO TEN METER CONVERSION KITS

KITS for AM—SSB—FM 40 Channel PLL chassis conversions

**DETAILED INSTRUCTIONS** for easy installation with minimum time and equipment

**BAND COVERAGE** flexibility provides up to 1 MHz coverage for most PLL chassis.

**PRICES** Low cost prices range from \$8.00 to \$50.00

All kits are in stock including several different FM kits.

**FREE CATALOG** Write or call today.

**INDEPENDENT  
CRYSTAL SUPPLY COMPANY**

P.O. Box 183  
Sandwich, Ma. 02563-0183  
(617) 888-4302

# Free!

## SWITCHING POWER SUPPLY HANDBOOK

From

**POWER  
GENERAL**

152 Will Drive, Canton, Massachusetts 02021  
Telephone (617) 828-6216, TWX 710-348-0200

## RELIABLE MICROWAVE TV ANTENNAS

**2.1 to 2.6 GHz Frequency Range**  
**34db System Gain (or Greater)**

Complete System (as pictured)	\$149.95
Down Converter Probe Style (Assembled and Tested)	\$ 64.95
Power Supply (12V to 16V DC+) (Assembled and Tested)	\$ 59.95



### PETERSON ELECTRONICS

4558 Auburn Blvd.  
Sacramento, CA 95841  
(916) 486-9071

C.O.D.'s  
**SPECIAL QUANTITY  
PRICING**  
Dealers Wanted

**1 YEAR WARRANTY  
PARTS & LABOR**



## Get lightning and static protection for receivers, transceivers, amplifiers...



R-T, HV Mark II Series

## with Transi-Trap™ Surge Protectors

Protect sensitive solid state and tube-type components from high-surge voltages produced by nearby lightning strikes, high wind and static build-up. Even distant storm fronts can cause damaging surges without warning or time for grounding.

Standard air-gap devices are ineffective due to their erratic performance. Transi-Trap's replaceable Arc-Plug™ cartridge utilizes a special ceramic gas-filled tube with precisely tailored firing speed and level, safely by-passing surges to ground. Fires thousands of times.

Transi-Trap Protectors are the first devices in the industry designed with "isolated ground" — keeps damaging arc-energy off the chassis and routes it directly to ground.

**Don't hook up your coax without one!**

The 200 W models are most sensitive, best for RCVRS and XCVRS. 2 kW models de-

signed for amplifiers. For maximum protection use both, with 200 W model between XCVR and AMP. All models include Arc-Plug cartridge.

### UHF "T-type" Connectors:

MODEL LT, UHF-type, 200 W output at 50 ohms ..... **\$19.95**

MODEL HT, UHF-type, 2 kW output at 50 ohms ..... **\$24.95**

### N "T-type" Connectors:

MODEL LT/N, N-type, 200 W output at 50 ohms ..... **\$39.95**

MODEL HT/N, N-type, 2 kW output at 50 ohms ..... **\$44.95**

### Super Ruggedized Super Low Loss

Models (0.1 dB at 500 MHz), for use through VHF/UHF, with UHF connectors:

MODEL R-T, 200 W output at 50 ohms ..... **\$29.95**

MODEL HV, 2 kW output at 50 ohms ..... **\$32.95**

At your Alpha Delta dealer. Or order direct in U.S.; add \$2 for postage and handling. MasterCard and VISA accepted. Ohio residents add Sales Tax.



# ALPHA DELTA COMMUNICATIONS

P.O. Box 571, Centerville, Ohio 45459 • (513) 435-4772



### RTTY - 50

Basic Terminal Unit

- 60 mA Loop Keying
- PLL Demod w/2 pole filter
- AFSK Generator

**\$79<sup>00</sup>**

Call or write for **FREE** catalog with over 65 P.C. Boards & Kits.

### RTTY - 100

Expanded Version of the Popular RTTY - 50

- AFSK
- 850/170
- TTL & RS232
- 60 mA Loop
- Loop Supply
- Auto Start
- 4 Pole Filters
- AGC (80db)

**\$189<sup>00</sup>**

## COMMUNICATIONS DESIGN INC.

1105 Lehr St. — West Memphis, Arkansas 72301  
(501) 735-4568

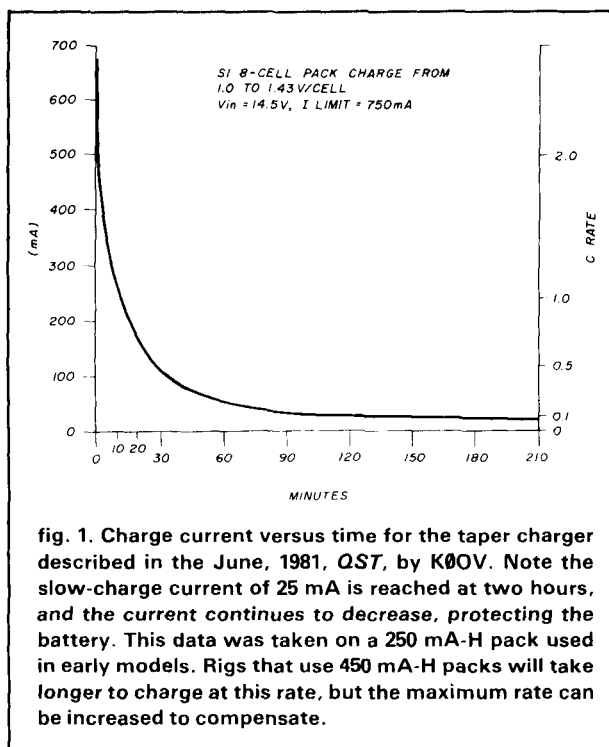

lier in the discharge cycle the step-down in voltage will occur. To the user it appears just like the memory effect described earlier, but is from a different cause. If your battery pack has shown symptoms of memory, chances are it's because it was overcharged. The traditional memory cure also works for the sustained overcharge effect.

What is needed is a way to stop charging the pack when a full charge is reached. W2GZD described such a slow charger in the October, 1981, *QST*.<sup>4</sup> When a specific voltage (1.43 volts per cell) is reached, the charger automatically cuts back to a trickle charge mode that doesn't cause heating.\* That's nice for a radio that sits on a charger 24 hours a day, but what about the ham-on-the-go who needs a quick charge? A good, safe, fast-charge method was described in the June, 1981, *QST*.<sup>5</sup> The unit charges a pack fully in only a couple of hours, and has a meter that shows the charging progress (fig. 1). Even though this is a fast charger, the battery doesn't warm up because the current tapers down to

\*Discharging the cells individually is recommended by some authors as a memory cure that won't cause cell reversal, but you should make sure the battery has the disease before applying the cure. Discharging cells deliberately in hopes of preventing memory is a complete waste of time and effort. This is the traditional memory cure.

\*Many hams erroneously call their little wall charger a trickle charger. Actually, the wall charger performs a slow charge (about 0.1C). A true trickle charge (0.02C or less) is used only to keep a battery charged. See Chapter 5 of the General Electric book for more details on rates of charge.

a slow charge value automatically as full charge is approached. The radio can remain in use during the fast charge. With a unit like this, you get the best of everything, fast charge, long battery life, and convenience.\*

One final caution about your charging system — beware of extreme temperature environments. At temperatures below about +5 degrees Celsius, overcharge quickly results in a buildup of hydrogen pressure which can result in cell damage. At very high temperatures, charging is not very efficient and cell temperature can rise to damaging levels during fast charging. In both extremes, the end point for charging is no longer 1.43 volts, meaning that a taper charger may not properly sense full charge. For best results, avoid trouble by doing your charging with the cells at or near room temperature. Don't leave your HT in a freezing car all night and charge it without allowing the cells to warm up first.

Here's how to make your Ni-Cds last:

1. Don't deliberately discharge packs to zero.
2. Don't continue to use your HT after the low battery indicator comes on.
3. Don't use a wall charger for more than 15 hours per charge.
4. Don't do a 15-hour slow charge on a battery that is only slightly discharged.
5. Do monitor pack voltage when slow-charging a partially discharged pack. Stop charging when voltage reaches 1.43 volts per cell, measured at room temperature with 0.1C charging current applied.
6. Don't charge your pack in freezing temperatures or in direct sunlight.
7. Don't continue to charge a battery if it gets warm during charging. Check for a shorted cell or misadjusted charger.
8. Do build or buy a taper charger for fast charging and operating with convenience and safety.

You won't need to worry about memory if you follow this advice.

## references

1. General Electric Company, *Nickel-Cadmium Battery Application Engineering Handbook*, Second Edition, 1975, pages 7-8.
2. S.F. Pensabene and J.W. Gould, "Unwanted Memory Spooks Nickel-Cadmium Cells," *IEEE Spectrum*, September, 1976, pages 32-36.
3. General Electric Company, pages 6-9 and 6-12.
4. D.W. Potter, "Those NiCad Batteries and How to Charge Them," *QST*, October, 1981, pages 34-35.
5. J.D. Moell, "A Fast Charger and Regulator for the Tempo S-1," *QST*, June, 1981, pages 34-35.

## ham radio

\*Don't confuse this circuit with regulators or battery beaters, which only operate the rig and don't charge the battery.

# ANTENNAS FOR HF, VHF, UHF

## Two Meter

**"The Big John"\*\*\*** 13 Element Quad 22' Boom 16.5dBd gain F/B 30 dB Mast Size Up to 2" Bandwidth 144-145 MHz \$129.95

**"The Little John"\*\*\*** 11 Element Quad 18' Boom 15.5 dBd gain F/B 30dB Mast Size 2" Bandwidth 144-145 MHz 109.95

**"PTG Special"\*\*\*** 9 Element Quad 13' Boom 14.8 DBd F/B 30 dB Bandwidth 144-146 MHz \$89.95

Featuring The Wondermatch Driven Element

## Six Meter

**"6-PTG-4"** 4 Element Yagi 13' Boom 12 dBi Mast Size 2" Longest Element 115" 50-51 MHz \$89.95

You've Heard About Us On The Air, So Call Collect Between 8AM-10PM Or Write For Details

\*Measured at JWL Laboratories

\*\*First Place Winner at Baton Rouge Gain Measuring Contest (7/31/82).

\*\*\*Second Place Winner at Baton Rouge Gain Measuring Contest (7/31/82).

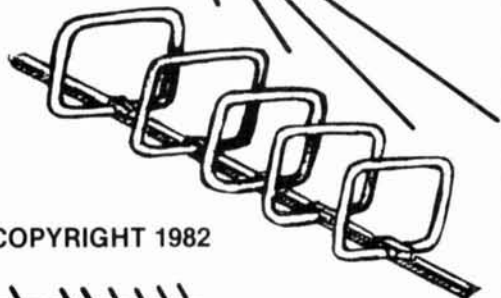

COPYRIGHT 1982

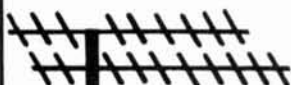

(713) 464-7720 Dick-WB5JWL  
Gordy-KD5NQ

**JWL ELECTRONICS**  
9138 Western Drive  
Houston, TX 77080

**STUDY  
TAPES**

CODE PRACTICE TAPES FROM HRPG — Practice copying Morse Code anytime, anywhere. Whether you're upgrading your present license or just trying to up your code speed, a large assortment allows you to choose exactly the kind of practice you need.

each tape \$4.95 2/\$8.95 3/\$12.95

### CODE PRACTICE TAPES

Here are three different straight code tapes consisting of randomly generated six character groups sent at different speeds. These tapes are excellent for building both the speed and copying accuracy needed for contesting, DXing and traffic handling.

HR-STC1 — \$4.95

7.5 wpm code for 25 minutes  
10 wpm code for 25 minutes  
15 wpm code for 25 minutes

HR-STC2 — \$4.95

15 wpm code for 50 minutes  
22.5 wpm code for 35 minutes

HR-STC3 — \$4.95

25 wpm code for 20 minutes  
30 wpm code for 20 minutes  
35 wpm code for 20 minutes  
40 wpm code for 20 minutes

### HI/LO SERIES — Code Study Tapes

In this unique series, characters are sent at high speeds with long pauses between each character. For example, HLC4 (15/2.5 wpm) consists of characters sent at a 15 wpm rate, but with 2.5 wpm spacing between each character. These tapes are excellent for the beginner who wants to practice copying higher speed code without the frustration of constantly getting behind.

HR-HLC1 — \$4.95

22.5/2.5 wpm code for 80 minutes  
22.5/7.5 wpm code for 20 minutes  
22.5/10 wpm code for 20 minutes  
22.5/13 wpm code for 20 minutes

HR-HLC3 — \$4.95

15/5 wpm code for 28 minutes  
15/7.5 wpm code for 28 minutes  
15/10 wpm code for 28 minutes

HR-HLC2 — \$4.95

HR-HLC4 — \$4.95

15/2.5 wpm code for 80 minutes

Please add \$1 for shipping.

**Ham Radio's Bookstore**  
Greenville, NH 03048

# A BETTER BALUN

from Barker & Williamson, Inc.

## BROAD BAND BALUNS

- Power Rating 2.5 KW-5 KW PEP
- Frequency Range 3.5-30 MHz
- SO 239 CONNECTOR

### Types Available

#### Model BC-1

50 ohms unbalanced to 50 ohms balanced

#### Model BC-2

50 ohms unbalanced to 200 ohms balanced

#### Model BC-3

50 ohms unbalanced to 300 ohms balanced

#### Model BC-4

50 ohms unbalanced to 600 ohms balanced

See your dealer or write:

Barker & Williamson, Inc.  
10 Canal Street  
Bristol, Pa. 19007

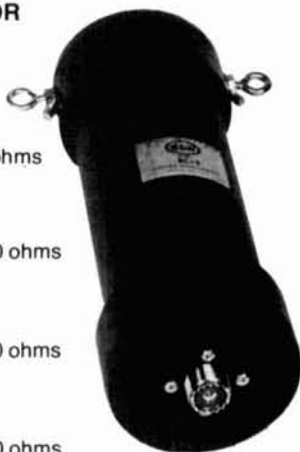

# ham radio TECHNIQUES

Bill W6SAI

Long, long ago, in a galaxy far, far away, or so it now seems, the World Administrative Radio Conference set aside certain new, narrow, high-frequency bands for use by the Amateur Service. Since January a year ago, over sixty countries have permitted Amateur operation in one of these bands, 10.1 MHz to 10.15 MHz. But the United States — whose Amateurs spearheaded the effort at WARC to get the new bands — has dragged its feet on granting permission to operate in these bands. The

reasons for the long delay make an interesting story, indeed.

Finally the combined efforts of the ARRL and a hot letter to the FCC from Barry Goldwater, K7UGA, opened the door and (as of this writing in September) it looks as if the 10-MHz band will be opened to U.S. Amateurs around the first of 1983, if not before. And that's good news for 1983!\*

The 10-MHz band is full of interesting DX when conditions are good, and one of the first questions raised by prospective 10-MHz operators concerns antennas for the new band, particularly all-band antennas that will cover existing bands plus the new ones. That means coverage of the 160, 80, 40, 30, 20, 17, 15, 12, and 10 meter bands, now available on the bandswitch of many of the new transceivers!

## simple all-band antennas

The first all-band antenna that comes to mind is the well-known center-fed long wire (fig. 1). Used with an open-wire transmission line and an antenna tuner at the station, this simple antenna will work well on any fre-

quency within the range covered by the tuner. (The tuner is sometimes called a Transmatch.) The tuner is coupled to the station equipment via a coaxial line and SWR indicator.

A second simple wire antenna that will cover all the Amateur high-frequency bands is the end-fed wire (fig. 2). A pi-network composed of a rotary inductor and two capacitors matches the wire antenna to a 50-ohm system.

Users of the end-fed antenna know that under certain conditions the antenna will tune up well, but the shack will be full of rf and feedback. This can cause erratic operation of the equipment, TVI, and other unpleasant problems. The cause of the diffi-

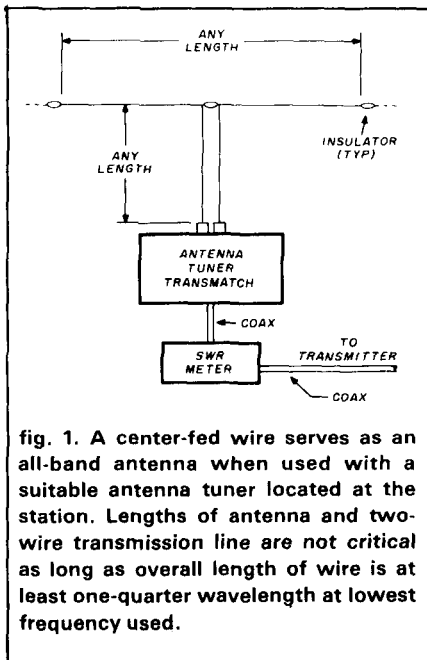

fig. 1. A center-fed wire serves as an all-band antenna when used with a suitable antenna tuner located at the station. Lengths of antenna and two-wire transmission line are not critical as long as overall length of wire is at least one-quarter wavelength at lowest frequency used.

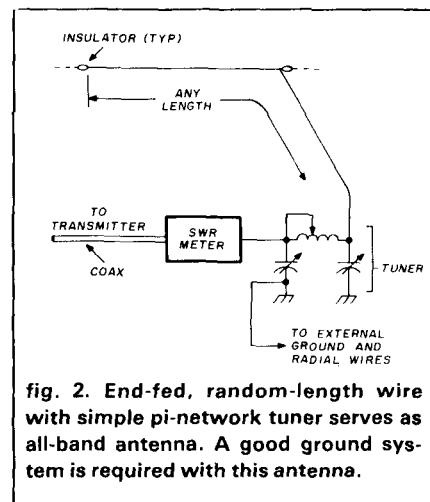

fig. 2. End-fed, random-length wire with simple pi-network tuner serves as all-band antenna. A good ground system is required with this antenna.

\*As of 3 pm EDST, October 28, U.S. Amateurs were permitted use of 10.100-10.109 and 10.115-10.150 MHz using A<sub>1</sub>, F<sub>1</sub> modes at a maximum power level of 250 watts.

culties is that the equipment is not at rf ground potential. Attaching a ground to the equipment usually doesn't help a bit, as the inductance of the ground wire upsets the situation even more. The use of quarter-wavelength radial ground wires cut to the operating frequency will solve this vexing problem. The radial ground wire is merely a length of insulated wire, free at the far end. It is cut to an electrical quarter wave at the operating frequency and affixed to the ground post of the equipment. The wire can be tossed on the floor behind the operating desk.

### the Australian broadband dipole

One of the best all-band antennas

in use is the so-called Australian dipole, which I briefly mentioned in an article in *CQ* magazine, October, 1974. After this article, the antenna sank into oblivion, at least in the United States.

In spite of this seeming lack of interest, the unusual antenna has continued to be used by Amateurs and commercial point-to-point services in other areas of the world. It eventually caught the attention of D.W. Harris (A22BX), the Deputy Director of Broadcasting (Engineering) at Radio Botswana in Southern Africa.

In common with many developing countries, Botswana has internal communications difficulties. Roads are often poor in rural areas and the telecommunications networks are

hardly developed. As a result, the news service of Radio Botswana is an important facet in passing information from remote districts to the capital.

Harris decided to use high-frequency SSB transceivers for this purpose — along with broadband antennas — with provisions for patching tape recorders into the transceivers. (Drake TR-7 transceivers were used with the SL-4000, 4-kHz passband filter.)

The problem of a broadband antenna which could be easily built and installed was formidable, as it had to provide less than a 2:1 SWR across the operating range. An article on the "Broadband Travelling Wave Dipole" appeared in the April, 1974, issue of *Amateur Radio* (Australia), which described an interesting antenna developed for use in the Australian Outback for the Flying Doctor radio service.

Harris and his staff built several Australian dipoles and tried them out with varying success. Finally, a modification of the original design produced a noncritical, wideband antenna which, with a special balun, showed less than a 2:1 SWR from below 3 MHz to over 20 MHz. The antenna was useful up to 30 MHz, as shown in the SWR plot of fig. 3.

### the modified Australian dipole

A simplified diagram of the A22BX version of the Australian dipole is

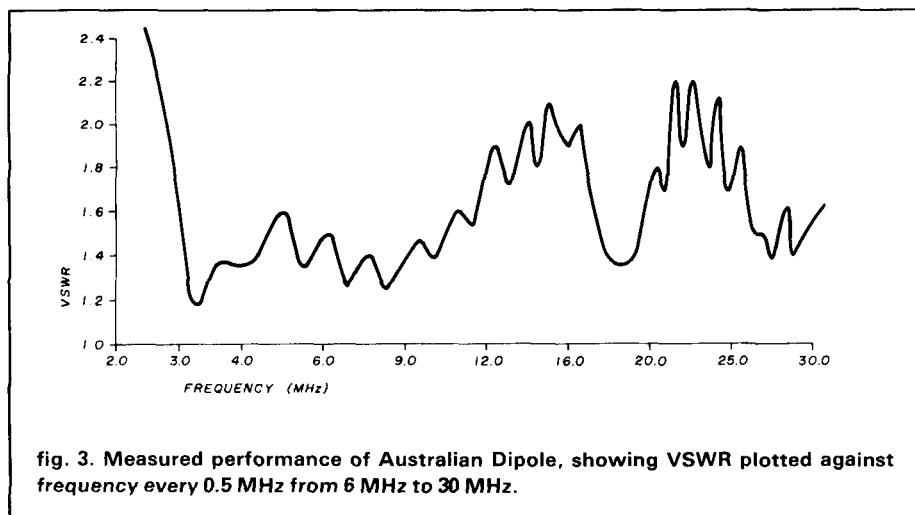

fig. 3. Measured performance of Australian Dipole, showing VSWR plotted against frequency every 0.5 MHz from 6 MHz to 30 MHz.

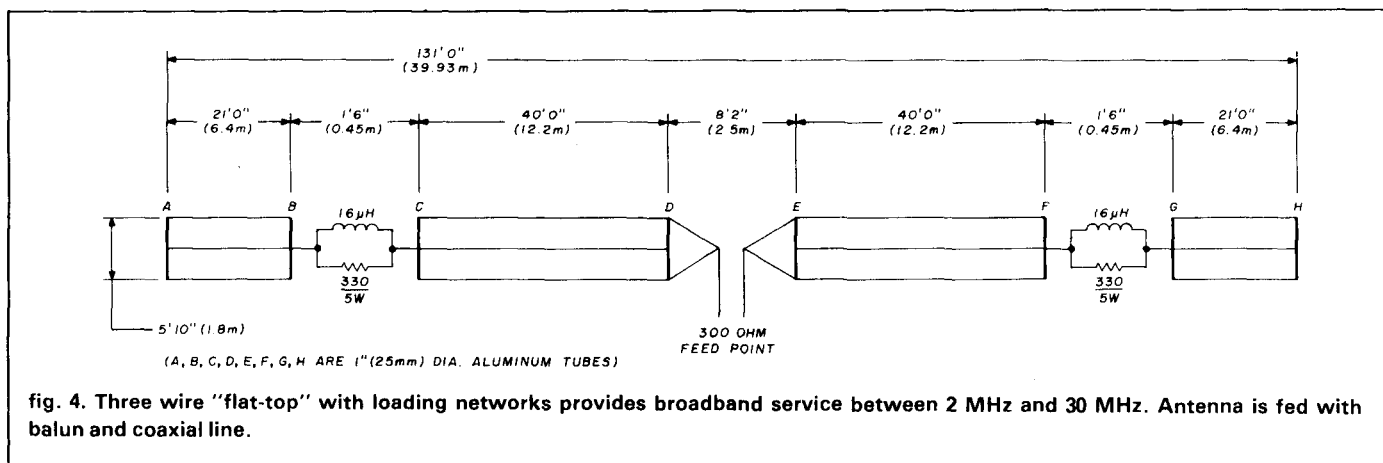

fig. 4. Three wire "flat-top" with loading networks provides broadband service between 2 MHz and 30 MHz. Antenna is fed with balun and coaxial line.

shown in **fig. 4**. Overall length is about 133 feet (40 meters). The antenna consists of a flat-top of three parallel wires, broken at intervals by simple loading networks placed in series with the wires. The feedpoint

impedance of the antenna is about 300 ohms. A toroid transformer wound on an Amidon two-inch diameter red core was used to make the impedance transformation to a 50-ohm line (**fig. 5**).

Details of antenna construction are shown in **fig. 6**. Hard-drawn copper wire is used for the flat-top to prevent stretching. The small networks are made of a 300-ohm, 5-watt composition resistor placed in parallel with a small inductor.

To hold the three wires of the antenna in position, yet allow easy handling on the ground, the networks are fastened to a framework that is big enough to attach the antenna wires to, as shown in the detail drawings. One-inch diameter PVC plastic conduit is used for the insulators. The aluminum spreaders were made from decorative aluminum L-shaped stock measuring about an inch wide and 1/2-inch thick, used for edging on Formica kitchen table tops. Small, 10-32 machine bolts, nuts, and hardware are used to hold the various strips and tubes together.

A22BX suggests using polypropy-

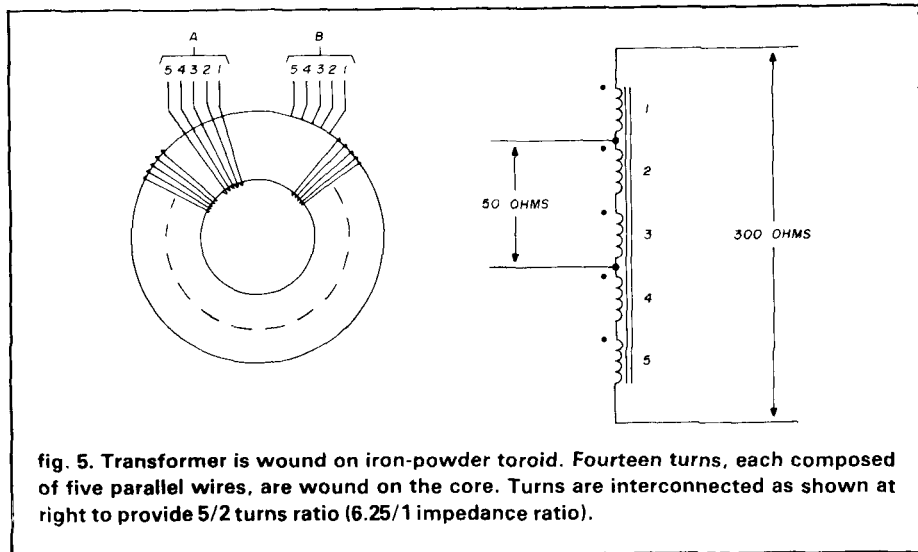

**fig. 5.** Transformer is wound on iron-powder toroid. Fourteen turns, each composed of five parallel wires, are wound on the core. Turns are interconnected as shown at right to provide 5/2 turns ratio (6.25/1 impedance ratio).

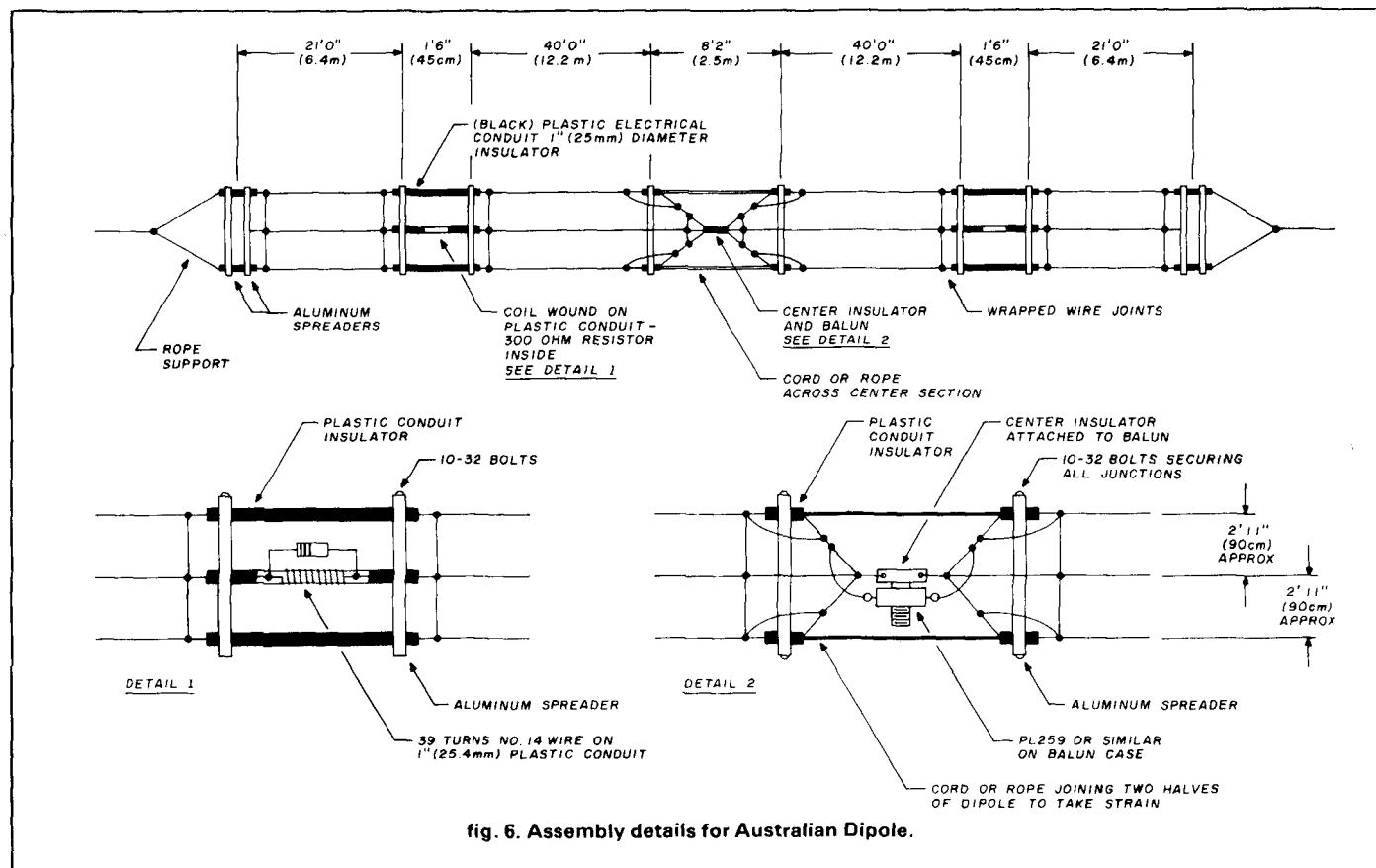

**fig. 6.** Assembly details for Australian Dipole.

lene plastic fiber rope in the antenna assembly to resist the effects of ultraviolet light. A suitable substitute rope is UV-resistant polyester material.

### antenna installation

The SWR curve shown for this antenna was measured through about 75 feet (23 meters) of coaxial line, and the antenna was suspended in the air at about 40 feet (12 meters). As can be seen, the SWR was excellent up to 15 MHz, rising between 15 and 16 MHz to 2.1:1, then dropping down to low values up to 21.5 MHz, where two SWR peaks at 2.2:1 appear. The SWR curve then gradually drops off to a low value at 30 MHz. Undoubtedly the antenna is also suitable for operation above 30 MHz, but higher frequency measurements were not made.

The SWR can be adjusted around 16 and 22 MHz by varying the height of the antenna above ground, and for a permanent installation, the ends of the Australian dipole can be varied in height to smooth out the SWR curve by taking advantage of ground reflection.

### the balun transformer

The matching transformer is wound on an iron-powder core having an outside diameter of two inches (5.08 cm). Inner diameter is 1 1/4 inches (3.18 cm). It is made by Micro-metals Corp. and has the Amidon part number T-200-2. It is coded red, and has a permeability of ten. It is recommended for operation over the range of 1 MHz to 30 MHz. The core is also sold by J.W. Miller Division of Bell Industries as part number T200-2.

To prepare the core, wrap it with a layer of 3M brand (or equivalent) glass epoxy tape to prevent arcing between winding and core. A single winding composed of five parallel wires is placed on the core. No. 14 AWG Formvar-insulated (about 1-mm diameter) wire is used. Fourteen turns of the five-wire combination are wound on the core. The approximate

length of wire used for each winding is about 5 feet (1.5 meters).

It is easier to wind the core than to explain how it's done. One set of wire ends is held in a vise and the five wires are smoothed out until they lie parallel. The parallel group of wires is stretched to remove kinks and then removed from the vise. The wires can be wound on the core all at once, or three wires can be wound on, followed by two, if that seems more convenient. In either case, the windings should all lie together.

When completed, continuity of each winding can be checked with an ohmmeter and the wire ends marked for convenience with a drop of epoxy paint. The last step is to interconnect the windings to get the proper transformation ratio. The windings are connected in series and the 300-ohm termination taken from the ends of the windings. The 50-ohm input points are tapped off between the ends of the second and third windings. This provides a turns ratio of 5:2 and an impedance transformation of 6.25:1.

When the transformer is completed it is given a coat of casting resin to protect it from the weather.

The transformer is attached to the center insulator of the antenna and a coaxial receptacle (SO-239), or a waterproof type-N connector, affixed to the balun terminals, and mounted to the center insulator.

When the antenna is completed, it should be raised in position and adjusted to provide the lowest value of SWR in the most important frequency regions of operation.

*Note:* This antenna is based upon a design by Dr. R.J.F. Guertier and G.E. Collyer of Antenna Engineering Australia (Pty.), Ltd. and was described in *Amateur Radio* (Australia), April, 1974. Information on the Australian Dipole is gathered from issues of *Amateur Radio*, the monthly publication of the Wireless Institute of Australia, Box 150, Toorak, Victoria 3142, Australia.

ham radio

Announcing

## NEW AUTOPATCH

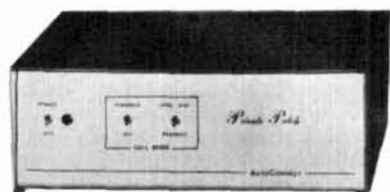

### PRIVATE PATCH

Introducing **Private Patch**. A giant step forward in non-sampling Autopatch/Interconnect technology, capability and standard features. Our revolutionary new techniques of audio and digital signal processing offer several advantages over conventional sampling/scanning type Autopatches: 1. The annoyance of continuous squelch tails is *totally* eliminated. Makes conversation much more natural and enjoyable. 2. In addition to superb simplex capability, operation through repeaters is made possible. 3. The only connections made to your base transceiver are to microphone and speaker jacks. **NO INTERNAL CONNECTIONS OR MODIFICATIONS NECESSARY!** Use **Private Patch** simplex for local operation, through a repeater for extended range. CW ID makes your Autopatch legal, and alerts you to incoming calls when ringback is turned on. Channel monitor logic precludes ringback transmission if channel is in prior use. Eliminates accidental interference. Five digit owner programmable access code and operator/long distance inhibit switch assure security and protect your phone bill. Positive control is assured by **Private Patch** logic functions. A fully digital timing approach eliminates all Timing adjustments. Three/six minute timer shuts down **Private Patch** if you drive out of range. Resettable with reset code for additional talk time as required. Self contained AC supply. Modular phone jack and modular phone cord provided. All electronics contained on one high quality glass circuit card. **Private Patch** contains 42 integrated circuits and 16 transistors. Send for additional information. Compare our features. (State call sign when ordering.)

Special Factory Direct  
Introductory Price

**1 YEAR WARRANTY**



\$489



Postage Paid

PHONE: (213) 540-1053

**AUTOCONNECT**

P.O. BOX 4155  
TORRANCE, CA 90510

DEALERSHIPS INVITED

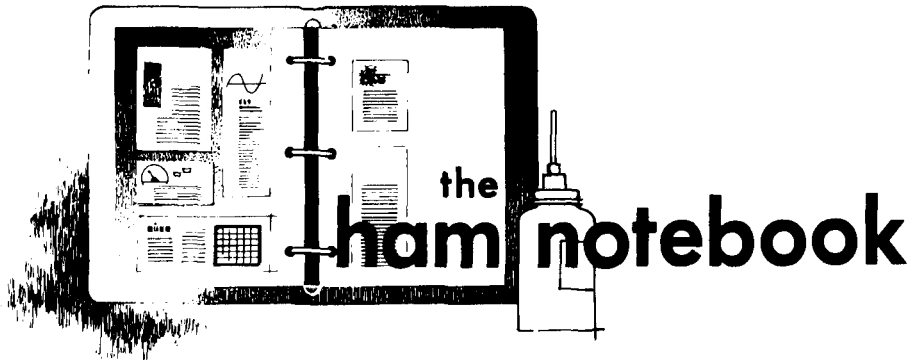

## switching circuit

I own a Chevy Vega in which I installed an ICOM IC-255A. I quickly discovered the tiny internal speaker, which was aimed at the floor of the car, could not compete with car and road noise. I couldn't afford to reinsulate the car and the Hatchback design wouldn't support an external speaker. However, there was already one well-placed speaker in the car — the one used for the built-in a-m radio.

I could have installed a switch easily, but that would have generated

automatically switch between receivers?

The IC-255A has an accessory socket that supplies 7 volts when the squelch is on. I tried using a transistor as a switch controlling a relay with my squelch voltage controlling the transistor. This was unsuccessful, it played havoc on my audio output from the ICOM. Dale Porray, AD7K, a local ham, came up with the perfect solution, using a voltage comparator circuit. The final circuit is shown in fig. 1.

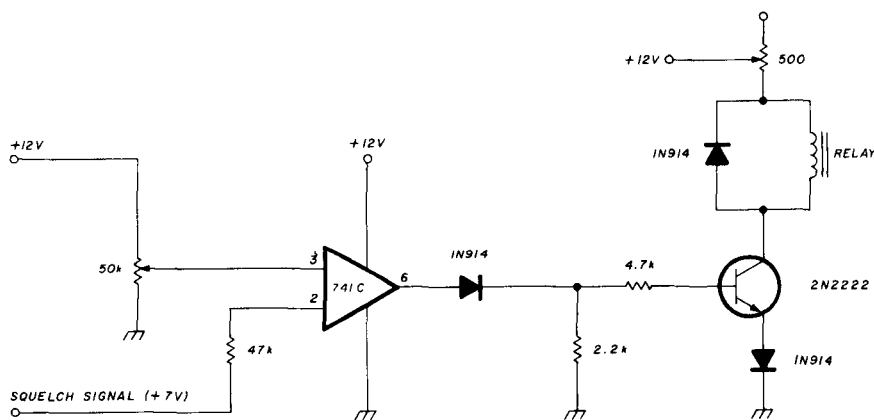

fig. 1. Voltage comparator circuit.

another problem: 2 meters in the Las Vegas area is not teeming with activity. I only needed to use my car's built-in speaker when 2 meters was active. I needed to be alerted when my ICOM was receiving so I could switch the car's speaker from the a-m radio to the ICOM. Going one step further, why not find some way to

The 741C monitors the difference between the squelch signal and the reference voltage obtained from the 50K pot. It also provides good isolation for the ICOM squelch circuit. Once a signal breaks the squelch, the 7 volts disappears and the 741C causes the 2N2222 to deactivate the control relay. The 500 ohm pot on the relay's

hot side is adjusted to prevent the relay from latching up. By obtaining 12 volts from the automobile and *not* the IC-255A accessory socket, the circuit activates only when the car's ignition is on. Since my IC-255A is wired directly to the battery to supply contin-

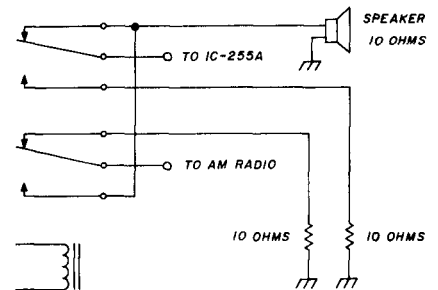

fig. 2. Continual voltage relays.

ual voltage to the memory circuits and to provide operation when I'm not driving, I used the relay configuration shown in fig. 2. The relay I used is Radio Shack part # 275-206. The 10 ohm resistors are 2 watts.

When the car's ignition is off, the IC-255A is wired directly to the car's speaker via the relay, and no unnecessary battery drain is made by operating the relay. When the car's ignition is on, I can enjoy listening to my car's a-m radio, knowing I will hear any signals coming through my IC-255A because my a-m radio will be muted.

This circuit can also be used to mute one radio in favor of another.

Construction and layout of the circuits are not critical. I used perf-board and direct wiring. I would recommend using an IC socket for the 741C. I got fancy when I wired the unit into the car: by using plugs and snap-on connectors, the entire unit can be removed and the speaker re-connected to the a-m radio in a matter of minutes.

This circuit is not unique to the IC-255A and can be applied to any receiver where a voltage is present when the squelch is on.

Fred Dahnke, WB6IQV



## SWD-1 VIDEO CONVERTER

FOR CABLE TV

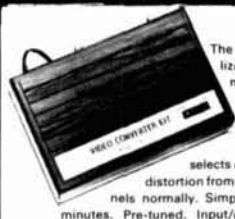

The SWD-1 Video Converter is utilized on cable TV systems to remove the KHz's signal from a distorted video (channel 3 in/out) and also pass thru the normal undistorted/detected audio signal. Rocker switch selects operating mode to remove KHz's distortion from the video or pass all other channels normally. Simple to assemble—less than 30 minutes. Pre-tuned. Input/output Channel 3. Impedance 75 ohms. 117VAC.

SWD-1 Video Converter Kit ..... \$69.95

## VTR ACCESSORIES

### SIMPLE SIMON VIDEO STABILIZER



Simple Simon Video Stabilizer, Model VS-125, eliminates the vertical roll and jitter from "copy guard" video tapes when playing through large screen projectors or on another VTR. Simple to use, just adjust the lock control for a stable picture. Once the control is set, the tape will play all the way through without further adjustments. Includes 12V power supply.

VS-125 Video Stabilizer, wired ..... Peg. 54.95 ..... **\$39.95**

## NEW VCR Quality

### MODULATOR



**Not a Game Type Modulator**  
The MPS-1 Kit converts Video/Audio signals to a crystal controlled RF output for TV Channels 3 and 4. The MPS-1 Modulator inputs are designed to match all TV Cameras and VCR's and features a voltage regulated power supply, power switch and LED indicator. No Tuning Required. Operates on 117VAC.

Assembly Time Approximately 5 Minutes  
MPS-1 Kit ..... **\$39.95**

## UHF ANTENNAS and ACCESSORIES

### MDS-AMATEUR-ETV 32 ELEMENT YAGI ANTENNA



- Not A Kit
- 1.9-2.5 GHz
- 38 1/2" Long
- 23dB Average Gain
- Commercial Grade
- Die Cast Waterproof Housing with 4 1/4" x 2 1/2" Area for Electronics

Includes P.C. Probe, F-61 Connector and Mounting Hardware  
MAE-2 32 Element YAGI Antenna ..... **\$23.95**

### Kato Sona's Down Converter Kit ★1.9 - 2.5GHz★

Designed for Simple Simon by former Japanese CD Amateur Magazine's UHF Editor/Engineer. Unit utilizes new ingenious Printed Circuit Probe for maximum gain. Circuit board fits inside MAE-2 antenna housing. Requires 1 hour assembly. IC and capacitors pre-soldered.

Model KSDC-KIT 1.9 - 2.5GHz Down Converter Kit ..... **\$34.95**

### Kato Sona's Regulated Variable DC Power Supply

For use with KSDC-KIT 1.9 - 2.5GHz Down Converter. Completely assembled with Attractive Cabinet, TV/Converter Mode Switch, Frequency Control and LED Indicator.

Model KSPS-1A Assembled Power Supply ..... **\$23.95**

**SPECIAL INTRODUCTORY SAVINGS**

ORDER ALL THREE ITEMS

MAE-2, KSDC-KIT and KSPS-1A for Only **\$74.95**

Regular price if ordered separately \$82.85

— CO-AX CABLES ARE NOT INCLUDED —

## ZYZZX VHF-UHF Wideband Antenna Amplifier

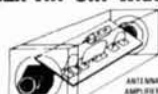

### Revolutionary New HYBRID IC Broadband Amplifiers

50 MHz - 900 MHz Model ALL-1 12dB Gain  
Model ALL-2 35dB Gain

These units are not available anywhere else in the world. Each unit will serve many purposes and is available in Kit or Assembled form. Ideal for outdoor or indoor use. I/O impedance is 75 ohms. Amplifiers include separate co-ax feed power supply. Easily assembled in 15 minutes. No coils, capacitors to tune or adjust.

ALL-1 Complete kit w/power supply ..... \$24.95  
ALL-1 W/rod/Tested w/power supply ..... \$34.95  
ALL-2 Complete kit w/power supply ..... 34.95  
ALL-2 W/rod/Tested w/power supply ..... 44.95

## Our New STVA 14.5dB GAIN, 14 ELEMENT CORNER REFLECTOR YAGI ANTENNA



STVA-3 Yagi Antenna, 14.5dB Gain, Selectable 75 or 300 ohm Channel 60-80 ..... \$19.95

STVA-4 Yagi Antenna, 14.5dB Gain, Selectable 75 or 300 ohm Channel 44-52 ..... \$19.95

RG-58/U 75 ohm Low Loss Coax Cable ..... 5.12/ft. F-59 Coax Connector ..... 5.39 ea.  
MT-1 Special UHF 75-300 ohm Matching Transformer ..... \$1.45 ea.

# Switch to Bambi!

## Electronically

**Bambi Electronic Video Switch ... makes switching of your VCR/VTR, Pay TV Decoders, Cable TV, Video Discs, Video Games, Closed Circuit TV, Antennae and Microcomputer as easy as pushing buttons.**

The Bambi Electronic Video Switch is an electronic switching network which can accept up to six different sources of video signals and provide the flexibility of directing the inputs to any or all of the three outputs.

Now you can eliminate ... the drudgery of disconnecting and reconnecting your video equipment each time you use it ... the tangled mess of cables which are impossible to trace out ... not being able to use more than one function at a time.

Bambi lets you enjoy using your video equipment the way it should be ... electronically and on line at the push of a button.

Model BEVS-1 Completely Wired and Assembled. Includes comprehensive Instruction/Operation Manual and Decal Set for customizing your Video Switch installation.

**\$129.95**



**FREE Bambi Poster with any purchase**



Bambi's front panel was designed with the user in mind. Computer styled construction, with soft-touch keyboard (rated for over 10 million operations), arranged in matrix form allows easy input/output selection without referring to charts. Functions selected through the keyboard are immediately displayed on the 18 LED status indicators.



Check the quality of Bambi against that of much higher priced competition. All solid state electronic switching provides low attenuation (3dB), wide frequency response (40-890 MHz), and excellent isolation between signal sources (each I/O section individually shielded for 65dB min. isolation).

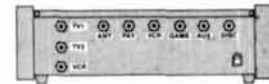

**Bambi's Specifications:**

- Input/Output Impedance ..... 75 ohm
- Signal Loss ..... 3dB ±1dB
- Noise ..... 4dB ±1dB
- Input Return Loss ..... 12dB min.
- Isolation ..... 65dB min.
- Power Req. .... 117VAC 60 Hz, 2W
- Dimensions ..... 10 1/4" W x 6 1/4" D x 3 1/4" H
- Weight ..... 4 1/2 lbs

## 7+11 SWD PARTS KITS

**MITSUBISHI VARACTOR UHF TUNER**  
Model UES-A56F  
**\$24.95**



ITEMS 1-14  
**SPECIAL \$119.95**

KIT No	PART No	DESCRIPTION	PRICE
1	1VT1-PWD	Varactor UHF Tuner, Model UES-A56F	\$24.95
2	2CB1-SWD	Printed Circuit Board, Pre-Drilled	18.95
3	3TP7-SWD	P.C.B. Potentiometers, 1-20K, 1-1K, and 5-10K ohms, 7-pieces	5.95
4	4FR35-SWD	Resistor Kit, 1/4 Watt, 5% Carbon Film, 32-pieces	4.95
5	5PT1-SWD	Power Transformer, PRI-117VAC, SEC-24VAC, 250ma	6.95
6	6PP2-SWD	Panel Mount Potentiometers and Knobs, 1-1KBT and 1-5KAT w/Switch	5.95
7	7SS14-SWD	IC's 7-pcs, Diodes 4-pcs, Regulators 2-pcs, Heat Sink 1-piece	29.95
8	8CE9-SWD	Electrolytic Capacitor Kit, 9-pieces	5.95
9	9CC33-SWD	Ceramic Disk Capacitor Kit, 50 W.V., 33-pieces	7.95
10	10CT-SWD	Variable Ceramic Trimmer Capacitor Kit, 5-65pfd, 8-pieces	5.95
11	11L4-SWD	Coil Kit, 18mhs 2-pieces, 22µhs 1-piece (prewound inductors) and 1 T37-12 Ferrite Torroid Core with 3 ft. of #25 wire	5.00
12	12ICS-SWD	I.C. Sockets, Tin Inlay, 8-pin 5-pieces	1.95
13	13SR-SWD	Speaker, 4dB Oval & Prepunched Wood Enclosure	14.95
14	14MISC-SWD	Misc. Parts Kit Includes Hardware, (6/32, 8/32 Nuts, & Bolts), Hookup Wire, Ant. Terms, DPDT Ant. Switch, Fuse, Fuseholder, etc.	9.95
When Ordering All Items, (1 thru 14), Total Price			139.95

## 7+11 PWD PARTS KITS

**INTRODUCING OUR 7+11 PWD PARTS KITS**

ITEMS 1-15  
**SPECIAL \$129.95**

KIT No	PART No	DESCRIPTION	PRICE
1	1VT1-PWD	Varactor UHF Tuner, Model UES-A56F	\$24.95
2	2CB1-PWD	Printed Circuit Board, Pre-drilled	18.95
3	3TP11-PWD	PCB Potentiometers 4-20K, 1-5K, 2-10K, 2-5K, 1-1K, and 1-50k (11 pieces)	8.95
4	4FR-31-PWD	Resistor Kit, 1/4W, 5% 29-pcs, 1/2 W 2-pcs	4.95
5	5PT1-PWD	Power Transformer, PRI-117VAC, SEC-24VAC at 500ma	8.95
6	6PP2-PWD	Panel Mount Potentiometers and Knobs, 1-1KBT and 1-5KAT with switch	5.95
7	7SS17-PWD	IC's 7-pcs, Diodes 4-pcs, Regulators 2-pcs Transistors 2-pcs, Heat Sinks 2-pcs	29.95
8	8CE14-PWD	Electrolytic Capacitor Kit, 14-pieces	6.95
9	9CC20-PWD	Ceramic Disk Capacitor Kit, 50 WV, 20-pcs	7.95
10	10CT5-PWD	Variable Ceramic Trimmer Capacitor, 5-65pfd, 5-pieces	4.95
11	11L5-PWD	Coil Kit, 18mhs 3-pcs, 22µhs 1-piece (prewound inductors) and 2 T37-12 Ferrite Toroid cores with 8 ft. #25 wire	6.00
12	12ICS-PWD	IC Sockets, Tin Inlay, 8 pin 4-pcs, 14 pin 1-pc and 16 pin 2-pcs	2.95
13	13SR-PWD	Enclosures with PM Speaker and Pre-drilled Backpanel for mounting PCB and Ant. Terms	14.95
14	14MISC-PWD	Misc. Parts Kit, Includes Hardware, (6/32, 8/32 Nuts & Bolts), Hookup Wire, Solder, Ant. Terms DPDT Ant. Switch, Fuse, Fuseholder, etc.	9.95
15	15MC16-PWD	Mylar Capacitors, 14-pcs and Silver Mica Capacitors 2-pcs	7.95
When Ordering All Items, (1-15), Total Price			159.95

**CUSTOMER NOTICE:** BUY WITH CONFIDENCE... BEWARE OF LOW QUALITY IMITATORS. All of our kits consist of New, 1st Class, RF Quality, Parts Engineered for Optimum Operation, not factory seconds or stock close-outs. We service your completed kits that you've purchased and built. You will never get stuck with a **BAG OF PARTS** when ordering from Simple Simon.

## SIMPLE SIMON ELECTRONIC KITS,™ Inc.

3871 S. Valley View, Suite 12, Dept. H, Las Vegas, NV 89103

In Nevada Call: **702-871-2892**

Outside Nevada Call: **1-800-782-3716**

NEED A OR MORE OF AN ITEM? WRITE FOR QUANTITY DISCOUNTS

Available by Mail Order Only  
Send Check\* or Money Order. Minimum Order: \$16.95. Add 10% Shipping and Handling on orders under \$40.00. For orders over \$40.00, add 5%. Minimum Shipping and Handling \$2.00. Cat. #1.00 — VISA and Mastercard Acceptable — \*Check orders will be held 30 days before shipping.

# RADIO WAREHOUSE

Breaking New Ground with  
A NEW Address  
A NEW Toll-Free Number

and **NEW LOW PRICES**

Call for your SPECIAL price on  
Kenwood, Yaesu, Icom, & TenTec



TS-830S

TS-930S

IC-740

IC-730

FT-102

Corsair

**1-800-433-3203**

IN TEXAS CALL 817-496-9000

P.O. BOX 50155

FT. WORTH, TEXAS 76105

## RF Porta-Tenna 5/8

TELESCOPIC VHF  
& UHF 5/8 WAVE FOR HTs

High Quality Maximum Performance

Gain (ref. 1/4 wave helical) ..... 6dB min.  
Bandwidth VHF (1.5:1 VSWR) ... 3.5MHz min.  
Bandwidth UHF (1.5:1 VSWR) ... 10MHz min.  
Maximum power ..... 5 watts  
Connector type ..... BNC

### LENGTH W/BNC CONNECTOR

Band	Extended	Collapsed
3.4M	44 1/4" (1124mm)	8 1/2" (207mm)
1 1/4M	32 1/2" (815mm)	7 1/4" (197mm)
3.4M	173 16" (435mm)	65 16" (160mm)

### Model No. Band Freq. MHz

191-214	2M	144-148
191-814	1 1/4M	220-225
191-914	3/4M	440-450

Models also available for  
148-174 and 450-512 MHz

PRICE - \$19.95 ppd. to 48 states via UPS  
For air delivery add \$1.50  
Florida residents add \$1.00 sales tax  
Payment by M.O. or cashiers ck. only

Dealer Inquiries Invited

### RF PRODUCTS

P.O. Box 33, Rockledge, FL 32955  
(305) 631-0775



## FREE! CABLE LOSS CHART IN WINTER CATALOG

### NEMAL ELECTRONICS COAXIAL CABLE SALE POLYETHYLENE DIELECTRIC

RG213 noncontaminating 96% shield mil spec	36"/ft.
RG214/U double silver shield 50 ohm	\$1.35/ft.
RG142/U double silver shield 50 ohm Teflon	95"/ft.
RG11U 96% shield 75 ohm mil spec	25"/ft.
* RG-8/U 96% shield Mil Spec (\$27.95/100) or 31"/ft.	
RG62A/U 96% shield mil spec 93 ohm	12"/ft.
RG-55B/U double shield (RG-58 size) 50 ohm	50"/ft.
* RG58U mil spec 96% shield (\$9.95/100) or 11"/ft.	

### LOW LOSS FOAM DIELECTRIC

RG-8X (Mini 8) 95% shield	(\$14.95/100) or 17"/ft.
* RG8U 80% shield	(\$15.95/100) or 19"/ft.
RG-8/U 97% shield 11 gauge (equiv. Belden 8214)	31"/ft.

RG58U 80% shield	07"/ft.
RG58U 95% shield	10"/ft.
RG59/U 100% foil shield TV type (\$7.00/100) or 10"/ft.	
HEAVY DUTY rotor 2-16 ga 6-18 ga	36"/ft.
Rotor cable 2-18 ga 6-22 ga	19"/ft.

### CONNECTORS MADE IN USA

Amphenol PL 259	79¢
PL-259 push-on adapter shell	10/\$3.89
PL-259 and/or SO-239	10/\$5.89
Double Male Connector	\$1.79
PL-258 Double Female Connector	98¢
1 ft. patch cord w/RCA type plugs each end	3/\$1.00
Reducer UG-175 or 176	10/\$1.99
UG-255 (PL-259 to BNC)	\$3.50
Elbow (M359) UHF Elbow	\$1.79
F59A (TV type)	10/\$1.99
UG 21 D/U Type N Male for RG8, Amphenol	\$3.00
UG-88C/U BNC Male for RG-58, Amphenol	\$1.25
UG 273 BNC-PL259 Amphenol	\$3.00
3/16 inch Mike Plug for Collins etc. (cutoff)	\$1.25

Call or write for Free Catalog  
shipping

Cable — \$3.00 1st 100 ft., \$2.00 each add'l 100 ft.  
Connectors — add 10%, \$3.00 minimum.  
COD add \$1.50. Florida Residents add 5%.

### NEMAL ELECTRONICS

1327N.E. 119St., Dept. H, N. Miami, FL 33161  
Telephone: (305) 893-3924



## Your Ham Tube Headquarters!

TOLL 800-221-0860 FREE  
TUBES

3-4002	\$85.00	6883B	\$6.75
3-5002	\$8500	7360	\$9.15
4-400A	\$80.00	7735A	\$29.50
4CX250B	\$50.00	8122	\$98.00
572B	\$39.50	8156	\$10.95
811A	\$12.00	8844	\$29.50
813	\$35.00	8873	\$175.00
8146B	\$6.50	8874	\$180.00
6360	\$4.25	8877	\$450.00
		8908	\$10.50

E.F. JOHNSON Sockets for 4CX250B & 4-400A — \$9.95

SEMICONDUCTORS		RF CONNECTORS	
MRF 245/SD1416	\$30.00	PL 259	10/\$4.95
MRF 454	\$18.95	PL 258	10/\$8.95
MRF 455	\$12.50	UG 175/176	10/\$1.60
		UG 255/U	\$2.50 ea.
MRF 644/SD1088	\$19.95	UG 273/U	\$2.25 ea.
2N3055	\$ 9.95	M 358	\$2.50 ea.
2N6084	\$12.50	M 359	\$1.75 ea.
		Type "N" twist on (RG8/U)	\$4.75

TOP BRAND Popular Receiving Tube Types  
FACTORY BOXED 75/80% OFF LIST

FREE LIST Available

Includes full line of RF Power Transistors.

Minimum Order \$25.

Allow \$3.00 Minimum for UPS Charges

Write or phone for free catalog.

TUBES—BOUGHT, SOLD AND TRADED



Premium Prices

Paid

For EIMAC Tubes

COMMUNICATIONS, Inc.

2115 Avenue X

Brooklyn, NY 11235

Phone (212) 646-6300

## COLLINS RECEIVER

R-388/COLLINS 51J3 RECEIVER - 0.5-30.5



Mhz AM-CW in 30 bands,  
1 Mhz per band. Band-  
width 0.2-6 KHz; 500  
KHz IF. 5-step crystal  
selectivity, "S" meter,  
and 100 KHz calibration

points. Requires 115/230 VAC 60 Hz; 10 1/2"x19"x13",  
56 lbs. sh. Used-repairable. ~~\$325~~ \$265.  
Checked ~~\$400~~ \$330. Manual, partial repro: \$10.

RF TUNER - from 400 watt transmitter; has Jennings  
UCSXF-1200 7.5 KV vacuum variable capacitor and 0.5-  
50 uH variable ribbon inductor. 24 VDC required for capacitor  
and inductor drives; schematic included. 13 1/2"x  
10 1/4"x5 1/4". 24 lbs. #RF1200/GRC14, used-exc. \$195.

Prices F.O.B. Lima, O. • VISA, MASTERCARD Accepted.  
Allow for Shipping • Write for Our FREE CATALOG  
Address Dept. HR • Phone: 419/227-6573

### FAIR RADIO SALES

1016 E. EUREKA, Box 1105, LIMA, OHIO 45004

## CADELL COIL CORP.

POULTNEY, VT. 05764 802-287-4055

WE LIKE TO WIND COILS—TRY US

### COILS FOR HOMEBILT

Sardine Sender 80 Meter GRP Rig	
QST Oct '79 p 15	\$8.50
QRP Transmatch 25 Watt Max	
ARRL Handbook p 350	7.00
Tuna Tin 2-WAS 40 Meter Transmitter	
QST May '76 p 21	5.25
Mini Miser's Dream Receiver	
QST Sep '76 p 21	13.25
20 Meter Direct Conversion Receiver	
QST Apr '78 p 12	7.00
Amplifier for HW-8 QRP Transceiver	
QST Apr '79 p 18	13.30
Harmonic Filter (for above) per band	4.50
Low Frequency Transmitter	
59 Sep '79 p 23	9.00

Prices include postage.

### BALUNS

Get POWER into your antenna. See ARRL Handbook p. 585 or 19-9 or 6-20.	
1KW—4:1 Impedance	\$12.00
2KW—4:1	14.50
1KW—6:1, 9:1, or 1:1 (pick one)	13.50
2KW—6:1, 9:1, or 1:1 (pick one)	16.00
100W—4:1, 6:1, 9:1, or 1:1 (pick one)	8.00

Many other interesting coil kits in our NEW LIST 5C. You must send a stamped envelope to receive our coil kit list.

## DIGITAL DISPLAY

30 DAY FREE TRIAL



YAESU  
HEATH  
DRAKE  
COLLINS  
KENWOOD

NEW YAESU DIGITAL DISPLAYS CONVERTED FOR YAESU-KENWOOD-HEATH-COLLINS AND DRAKE TRANSCEIVERS, RECEIVERS AND TRANSMITTERS. 5 ACTIVE RED LED DIGITS READ DOWN TO 10 HZ. REAR PANEL 10 HZ DIGIT DEFEAT SWITCH. FROM COLD MAX. 100 HZ DRIFT IN 20 HRS. 1 3/8" HIGH, 4 1/2" WIDE & 6 1/2" DEEP. STEEL CASE IS BLACK. LOWER FRONT PANEL IS BRUSHED ALUMINUM. UNITS FOR MODEL NUMBERS UNDERLINED WORK WITHOUT ANY INSTALLATION BY PLUGGING INTO EXISTING JACKS ON THE RADIOS. MODELS WITH AN \* APOSTROPH HAVE A POWER SUPPLY TRANSFORMER AND OFF SWITCH. ALL POSTAGE PAID. IF YOUR EXTERNAL VFO JACK IS USED FOR A VFO, REC-OR TRANSMITTER, FOR A MALE/FEMALE PLUG/JACK ADD----- \$5.00

FT101 SERIES FT101 TS2205(A) PLUG INTO REAR JACK FOR VFO SIGNAL AND POWER. NO INSTALLATION REQUIRED. ----- \$110.00

TS220 TS220 TS300 TS600 RS99 TS999 FR101 FL101 FR67

FT148B HW104 ----- ALL PARTS & INFO. --- \$115.00

\*725 SERIES \*YOM SERIALS \*325 SERIES \*R-4 SERIES FROX RECEIVERS

\*FT100 \*FT400 & 401 \*FT560 & 570 \*HW100-101 \*SR100-102

\*SR300-301 \*HR1680 ----- ALL PARTS & INFO. --- \$125.00

YC221 FOR FT221(A) w/ SERIAL- FT221 15700. 7 DIG. --- \$75.00

SEND U.S. CASHIERS CHECK OR M.O., 30 DAY MONEY BACK. YOU PAY RETURN POSTAGE. WRITE WITH MOD. & SERIAL NO. FOR INFORMATION. WRITE IF YOUR RADIO IS NOT LISTED--WILL MAKE ONE 30-WARRANTY.

### GRAND SYSTEMS

P.O. BOX 2171 20552 40A AVE.  
BLAINE WASH. LANGLEY B.C.  
U.S.A. 98250 (604) 530 4551 CANADA V5A2Y8

## New '83 Catalog



Over 3000 items listed:

IC's, Sockets, Connectors, Capacitors, Diodes, Transistors, Heat Sinks, Fans, Crystals, Memories, Kits, Computer Accessories, Keyboards, Power Supplies, Disk Drives, etc. Send \$1.00 postage for your FREE 1983 Jameco Catalog.

**Jameco**®  
ELECTRONICS  
1355 Shoreway Road  
Belmont, CA 94002  
(415) 592-8097

## TEN FM

JOIN THE FUN and EXCITEMENT

29.3-29.7



\$ 68.95  
FM.10 KIT

Kit includes a two color, silk screened aluminum chassis, the deluxe CYBERNET (Hy Gain) CB board, True FM discriminator kit, crystal, jacks, pots, hardware and a thorough instruction manual.

HAMFEST SPECIAL \$33.00

Same as above, less chassis, hardware

TEN METER FM HANDBOOK \$4.95

The One-Stop Parts House for 10 FM!

**MELCO**

include \$2.00 for postage and handling.

P.O. Box 26  
Marissa, Ill. 62257  
618-295-3000

## HAVE RTTY—WILL TRAVEL



Yes, now you can take it with you! The new **HAL CWR-6850 Telereader** is the smallest RTTY and CW terminal available, complete with CRT display screen. Stay active with your RTTY and CW friends even while traveling. Some of the outstanding features of the CWR-6850 are:

- Send and receive ASCII, Baudot, and Morse code
- RTTY and Morse demodulators are built-in
- RTTY speeds of 45, 50, 57, 74, 110, and 300 bau<sup>-1</sup>
- High or Low RTTY tones
- Send and receive CW at 3 to 40 wpm
- Built-in 5 inch green CRT display
- Four page video screen display
- Six programmable HERE IS messages
- Pretype up to 15 lines of text
- External keyboard included
- Runs on +12 VDC @ 1.7 Amperes
- Small size (12.75" x 5" x 11.5")

Write or call for more details. See the CWR-6850 at your favorite HAL dealer.



**HAL COMMUNICATIONS CORP.**

BOX 365

URBANA, ILLINOIS 61801

217-367-7373

## DIRECTION FINDING?

- ★ Doppler Direction Finding
- ★ No Receiver Mods
- ★ Mobile or Fixed
- ★ Kits or Assembled Units
- ★ 135-165 MHz Standard Range



- ★ Circular LED Display
- ★ Optional Digital Display
- ★ Optional Serial Interface
- ★ 12 VDC Operation
- ★ 90 Day Warranty

**New Technology** (patent pending) converts any VHF FM receiver into an advanced Doppler Direction Finder. Simply plug into receiver's antenna and external speaker jacks. Use any four omnidirectional antennas. Low noise, high sensitivity for weak signal detection. Kits from \$270. Assembled units and antennas also available. Call or write for full details and prices.

**DOPPLER SYSTEMS,**

5540 E. Charter Oak, (602) 998-1151  
Scottsdale, AZ 85254

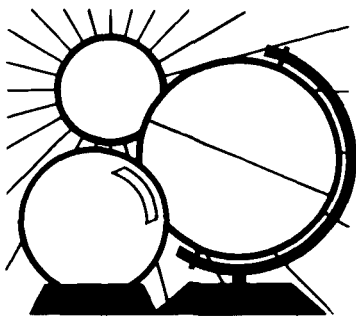

# DX FORECASTER

Garth Stonehocker, KØRYW

## last minute forecast

The higher frequencies (10-20 meter bands) are expected to provide excellent DX openings during the third week of this month. Openings will probably build up only the first two weeks and fall off the last week of the month. The lower frequency bands (nighttime, 40 to 160 meters) will probably have very good DX throughout the month and enhanced DX the first and last week. Disturbed conditions may be enhancing trans-equatorial paths and creating east/west path problems around the 5th, 14th, 24th, and 31st of the month.

Lunar perigee and full moon are on January 28 this month. There will be an intense but short meteor shower lasting a few hours some time between January 2nd and 4th. It is known as the Quadrantid shower.

Many of the DXers using the radio propagation quality formula (August, 1982, DX Forecaster) have expressed an interest in how the formula came to be. I thought I'd pass this along:

The North Atlantic Radio Warning Service (NARWS) of the National Bureau of Standards of the Department of Commerce provided this service via WWV broadcasts from World War II until 1978. The forecast was done for every six hours; that is, four times daily. The last two hours of monitoring of each six-hour period

was the basis for the next six-hour forecast. Radio circuits crossing the North Atlantic were monitored and evaluated by the FCC, RCA, ITT, the Navy, the Coast Guard, the Canadian Broadcasting Corp., and NARWS. The forecast was also based on solar-geophysical and ionospheric conditions which were called and monitored by the NARWS.

Statistical analysis was done to keep the evaluations within standard-deviation limits. Mr. Harris, one of the forecasters, noticed over the years that two of the useful predictors were the radio flux values and geomagnetic A or K variability indices. He made computerized comparisons of flux values and variability indices to the observed radio quality monitored evaluations from 1947 (the start of Ottawa, Canada, 2800-MHz radio flux measurements). The mathematical formulation was obtained from these correlations. The calculated quality values from the formula were then compared with the observed quality values over the span of years from 1947 into the latter 1970s; they matched well in summer but toward each winter the calculated quality was greater than the observed. Therefore utilizing a modeling technique, the seasonal term,  $\theta$ , was developed, using the day of the year and a cosine function to gradually lower the calculated number. An ear-

lier version of  $\theta$  was inadvertently given in August. The correct formula is:  $\theta = 1.0 - 0.2625 \cos^2 0.49315X$ .

An attempt was made to determine why  $\theta$  was needed, but several effects could have been involved: enhanced sporadic-E signal strength in summer; lowered F2 region heights (therefore more hops required across the Atlantic) in the high latitude trough in winter; or higher winter absorption (known as the winter absorption anomaly) than the closer-sun higher radio flux can account for. These are postulations that have been proposed but not fully researched since it is very difficult to sort out individual geophysical mechanisms operating in such cases.

## band-by-band summary

*Ten meters* will be open occasionally for F2 long skip by the trans-equatorial one-long-hop propagation mode (TEM). The openings will follow the sun during the day and into late evening. Geomagnetic disturbances will enhance this mode, as will high solar flux. Openings may favor southern Africa, South America, and Australia — particularly southern Africa.

*Fifteen Meters* can have the same TEM modes as 10 meters. The openings should be more frequent. Worldwide DX is prevalent from after sunrise until well after sunset during the periods of high solar flux (listen to WWV at 18 minutes after the hour for reports on solar and geomagnetic conditions). A good practice when bands are open is to work the highest band that is open first, then drop down in frequency to catch each band until it closes.

*Twenty meters* will be open most days and nearly through the night to some areas of the globe, with long skips of 1000-2500 miles and plenty of short-skip of 1200 miles near midday. Both propagation modes follow the sun across the sky: east, south, then west. This is the workhorse of the bands for DX as well as traffic handling.

**WESTERN USA**

GMT	PST	Direction																		
		N	NE	E	SE	S	SW	W	NW	ASIA FAR EAST	EUROPE									
0000	4:00	10	20	15	15	20	10	10	10	10	10	10	10	10	10	10	10	10	10	10
0100	5:00	15*	20	15	15	20	10	10	10	10	10	10	10	10	10	10	10	10	10	10
0200	6:00	15	20	15	15	15	15	15	10	10	10	10	10	10	10	10	10	10	10	10
0300	7:00	15	40	20	15	15	15	15	15	15	15	15	15	15	15	15	15	15	15	15
0400	8:00	20	40	20	20	20	15	15	15	15	15	15	15	15	15	15	15	15	15	15
0500	9:00	—	40	20	20	20	15	15	15	15	15	15	15	15	15	15	15	15	15	15
0600	10:00	—	40	—	20	20	15	15	15	15	15	15	15	15	15	15	15	15	15	15
0700	11:00	—	—	—	20	20	20	20	20	20	20	20	20	20	20	20	20	20	20	20
0800	12:00	—	—	20	20	20	20	20	20	20	20	20	20	20	20	20	20	20	20	20
0900	1:00	—	—	20	40	40	40	20	20	20	20	20	20	20	20	20	20	20	20	20
1000	2:00	—	—	—	40	40	40	40	40	40	40	40	40	40	40	40	40	40	40	40
1100	3:00	—	—	—	—	—	40	40	40	40	40	40	40	40	40	40	40	40	40	40
1200	4:00	—	—	—	—	—	40	40	40	40	40	40	40	40	40	40	40	40	40	40
1300	5:00	—	—	—	—	—	40	40	40	40	40	40	40	40	40	40	40	40	40	40
1400	6:00	—	—	20	—	—	—	—	—	—	—	—	—	—	—	—	—	—	—	—
1500	7:00	—	—	20*	20	20	—	—	—	—	—	—	—	—	—	—	—	—	—	—
1600	8:00	20	15	10	10	10	—	—	—	—	—	—	—	—	—	—	—	—	—	—
1700	9:00	20	15	10	10	10	—	—	—	—	—	—	—	—	—	—	—	—	—	—
1800	10:00	20	15	10	10	10	—	—	—	—	—	—	—	—	—	—	—	—	—	—
1900	11:00	15	20	10	10	10	20	10	10	10	15	15	15	15	15	15	15	15	15	15
2000	12:00	15	20	15	10	10	—	—	—	—	—	—	—	—	—	—	—	—	—	—
2100	1:00	15	20	15	10	10	—	—	—	—	—	—	—	—	—	—	—	—	—	—
2200	2:00	15	40*	15	15	15	—	—	—	—	—	—	—	—	—	—	—	—	—	—
2300	3:00	10	20	15	15	15	—	—	—	—	—	—	—	—	—	—	—	—	—	—

**MID USA**

GMT	MST	Direction																		
		N	NE	E	SE	S	SW	W	NW	ASIA FAR EAST	EUROPE									
0000	5:00	15	20	15	15	20*	10	10	10	10	10	10	10	10	10	10	10	10	10	10
0100	6:00	15	20	15	15	15	10	10	10	10	10	10	10	10	10	10	10	10	10	10
0200	7:00	15	40	20	15	15	10	10	10	10	10	10	10	10	10	10	10	10	10	10
0300	8:00	20	40	20	15	15	15	15	15	15	15	15	15	15	15	15	15	15	15	15
0400	9:00	20	40	20	20	15	15	15	15	15	15	15	15	15	15	15	15	15	15	15
0500	10:00	—	40	20	20	15	15	15	15	15	15	15	15	15	15	15	15	15	15	15
0600	11:00	—	40	20	20	20	20	20	20	20	20	20	20	20	20	20	20	20	20	20
0700	12:00	—	40	20	20	20	20	20	20	20	20	20	20	20	20	20	20	20	20	20
0800	1:00	—	20	20	20	20	40	40	40	40	40	40	40	40	40	40	40	40	40	40
0900	2:00	—	—	—	40*	20	40	40	40	40	40	40	40	40	40	40	40	40	40	40
1000	3:00	—	—	—	—	40	—	—	—	—	—	—	—	—	—	—	—	—	—	—
1100	4:00	—	—	—	—	—	—	—	—	—	—	—	—	—	—	—	—	—	—	—
1200	5:00	—	—	—	—	—	—	—	—	—	—	—	—	—	—	—	—	—	—	—
1300	6:00	—	—	20	15	15	10	10	10	10	10	10	10	10	10	10	10	10	10	10
1400	7:00	20	15	15	10	10	—	—	—	—	—	—	—	—	—	—	—	—	—	—
1500	8:00	20	15	10	10	10	—	—	—	—	—	—	—	—	—	—	—	—	—	—
1600	9:00	20	15	10	10	10	—	—	—	—	—	—	—	—	—	—	—	—	—	—
1700	10:00	20	15	10	15*	—	—	—	—	—	—	—	—	—	—	—	—	—	—	—
1800	11:00	20	15	10	10	10	—	—	—	—	—	—	—	—	—	—	—	—	—	—
1900	12:00	20	15	10	10	10	15	15	15	15	15	15	15	15	15	15	15	15	15	15
2000	1:00	20	20	10	10	10	—	—	—	—	—	—	—	—	—	—	—	—	—	—
2100	2:00	20	20	10	10	10	—	—	—	—	—	—	—	—	—	—	—	—	—	—
2200	3:00	—	40*	15	15*	20	10	10	10	10	10	10	10	10	10	10	10	10	10	10
2300	4:00	—	20	15	15*	15*	10	10	10	10	10	10	10	10	10	10	10	10	10	10

**EASTERN USA**

GMT	EST	Direction																			
		N	NE	E	SE	S	SW	W	NW	ASIA FAR EAST	EUROPE										
0000	7:00	15	20	15	15	15	15	15	15	15	15	15	15	15	15	15	15	15	15	15	
0100	8:00	15	20	15	15	15	15	15	15	15	15	15	15	15	15	15	15	15	15	15	15
0200	9:00	15	20	20	20	20	20	20	20	20	20	20	20	20	20	20	20	20	20	20	20
0300	10:00	20	40	20	20	20	20	20	20	20	20	20	20	20	20	20	20	20	20	20	20
0400	11:00	—	40	20	20	20	20	20	20	20	20	20	20	20	20	20	20	20	20	20	20
0500	12:00	—	40	20	20	20	20	20	20	20	20	20	20	20	20	20	20	20	20	20	20
0600	1:00	—	40	20	20	20	20	20	20	20	20	20	20	20	20	20	20	20	20	20	20
0700	2:00	—	40	—	20	20	20	20	20	20	20	20	20	20	20	20	20	20	20	20	20
0800	3:00	—	40	—	40	40	40	40	40	40	40	40	40	40	40	40	40	40	40	40	40
0900	4:00	—	20	—	—	40	40	40	40	40	40	40	40	40	40	40	40	40	40	40	40
1000	5:00	—	—	—	—	—	—	—	—	—	—	—	—	—	—	—	—	—	—	—	—
1100	6:00	—	—	20	20	20	20	20	20	20	20	20	20	20	20	20	20	20	20	20	20
1200	7:00	—	—	15	15	15	15	15	15	15	15	15	15	15	15	15	15	15	15	15	15
1300	8:00	20	—	10	10	10	10	10	10	10	10	10	10	10	10	10	10	10	10	10	10
1400	9:00	20	10	10	10	10	10	10	10	10	10	10	10	10	10	10	10	10	10	10	10
1500	10:00	20	10	10	10	10	10	10	10	10	10	10	10	10	10	10	10	10	10	10	10
1600	11:00	15	10	10	10	15*	—	—	—	—	—	—	—	—	—	—	—	—	—	—	—
1700	12:00	15	15*	10	10	15*	—	—	—	—	—	—	—	—	—	—	—	—	—	—	—
1800	1:00	—	15	10	10	15*	—	—	—	—	—	—	—	—	—	—	—	—	—	—	—
1900	2:00	—	15	10	10	15*	—	—	—	—	—	—	—	—	—	—	—	—	—	—	—
2000	3:00	—	20	10	10	10	20	10	10	10	15	15	15	15	15	15	15	15	15	15	15
2100	4:00	—	20	10	10	10	20	10	10	10	15*	15*	15*	15*	15*	15*	15*	15*	15*	15*	15*
2200	5:00	—	40*	15	10	10	20	10	10	10	10	10	10	10	10	10	10	10	10	10	10
2300	6:00	15	20	15	15	15	20	10	10	10	10	10	10	10	10	10	10	10	10	10	10

\*Look at next higher band for possible openings.



# Food for thought.

Our new Universal Tone Encoder lends its versatility to all tastes. The menu includes all CTCSS, as well as Burst Tones, Touch Tones, and Test Tones. No counter or test equipment required to set frequency—just dial it in. While traveling, use it on your Amateur transceiver to access tone operated systems, or in your service van to check out your customers' repeaters; also, as a piece of test equipment to modulate your Service Monitor or signal generator. It can even operate off an internal nine volt battery, and is available for one day delivery, backed by our one year warranty.

- All tones in Group A and Group B are included.
- Output level flat to within 1.5db over entire range selected.
- Separate level adjust pots and output connections for each tone Group.
- Immune to RF
- Powered by 6-30vdc, unregulated at 8 ma.
- Low impedance, low distortion, adjustable sinewave output, 5v peak-to-peak
- Instant start-up.
- Off position for no tone output.
- Reverse polarity protection built-in.

## Group A

67.0 XZ	91.5 ZZ	118.8 2B	156.7 5A
71.9 XA	94.8 ZA	123.0 3Z	162.2 5B
74.4 WA	97.4 ZB	127.3 3A	167.9 6Z
77.0 XB	100.0 1Z	131.8 3B	173.8 6A
79.7 SP	103.5 1A	136.5 4Z	179.9 6B
82.5 YZ	107.2 1B	141.3 4A	186.2 7Z
85.4 YA	110.9 2Z	146.2 4B	192.8 7A
88.5 YB	114.8 2A	151.4 5Z	203.5 M1

- Frequency accuracy,  $\pm .1$  Hz maximum -  $-40^{\circ}\text{C}$  to  $+85^{\circ}\text{C}$
- Frequencies to 250 Hz available on special order
- Continuous tone

## Group B

TEST-TONES:	TOUCH-TONES:	BURST TONES:			
600	697 1209	1600	1850	2150	2400
1000	770 1336	1650	1900	2200	2450
1500	852 1477	1700	1950	2250	2500
2175	941 1633	1750	2000	2300	2550
2805		1800	2100	2350	

- Frequency accuracy,  $\pm 1$  Hz maximum -  $-40^{\circ}\text{C}$  to  $+85^{\circ}\text{C}$
- Tone length approximately 300 ms. May be lengthened, shortened or eliminated by changing value of resistor

Model TE-64 \$79.95

**COMMUNICATIONS SPECIALISTS**

426 West Taft Avenue, Orange, California 92667  
(800) 854-0547/ California: (714) 998-3021



Forty meters is the transition band in to all-night propagation as well as some short skip during the day. Most areas of the world can be worked from darkness till just before sunrise. Hops shorten on this band to about 2000 miles, but the number of hops can increase since signal absorption is low during the night.

Eighty meters is traditionally a rag-chewer's band but much DX work is also possible. The band operates much like 40 meters except that the hop distances shorten to about 1500 miles. Noise from distant thunderstorms is so low as to make these bands a joy to work this time of year. The path direction follows the darkness across the earth (east, south, then west). Just wiggle in between the QRM.

One-sixty meters will be about like 80 meters, with reduced range to 1000 miles. It provides good DX for enthusiastic DXers. The new band power and frequencies should increase activity here, so we'll be listening.

ham radio

BUCKMASTER PUBLISHING'S  
1982-1983

# AMATEUR RADIO CALL DIRECTORY

THE BARGAIN  
AT \$12.95  
Plus Shipping



U.S.  
Listings

Active Radio Amateurs need an affordable directory of call listings. No need to put off buying that important call directory because of price.

The Buckmaster Publishing Call Directory is a no frills directory of over 411,000 U.S. Radio Amateurs (as licensed by the U.S. Gov't.). 8 1/2 x 11, easy to handle and read format. Completely updated.

Also available for the first time ever—

(Alphabetically arranged—Sold separately)

- **Geographical Index**  
by State, City and Street No. and Call
- **Name Index**  
by Name and Call

Ordering Information:

- **Directory—\$12.95**
- **Geographical Index—\$25.00**
- **Name Index—\$25.00**

Add \$3.00 Shipping to all orders.  
Full satisfaction  
or your money back.

Send your order—enclosing check or money order in U.S. dollars to:

**Buckmaster Publishing**  
70-D Florida Hill Road  
Ridgefield, CT 06877 U.S.A.



## APPLIED INVENTION

THE SOURCE FOR SOLID STATE / STATE-OF-THE-ART

### GaAs FETS by MITSUBISHI

2M — Ku Band. Very low noise and medium power.  
MGF1200 0.3dBNF @ 144, 0.6 dBNF @ 432 \$10.20  
MGF1400 0.4 dBNF @ 432, 1.1 dBNF @ 4GHz \$15.00  
MGF1412 GUARANTEED 0.8, 0.9 or 1.0 dBNF @ 4GHz  
Also: MGF1400, MGF1403, MGF1801 & the NEW MGF1100 & MGF1202

### Microwave Modules

**MITSUBISHI X BAND** Hybrid Integrated Circuits with Dielectric Resonator (0.12MHz/°C) GaAs FET Oscillators  
FD-1010X 10.4 GHz, 15mw out, UER100 Flange \$37.50  
FD-1210Y 11.5 or 12.0 GHz, UER120 Flange \$37.50  
FD-UP11KF Complete Heterodyne Rx, 10.468 GHz LD \$34.50  
Use with 2 GHz IF for 12 GHz Satellite TVRO  
FD-OP13KF Doppler Module 10.525 GHz UER100 Flange \$41.00  
X-Band 15 dBm die cast horn antenna (UER100) \$17.00  
GaAs FET Preamp 1.7-2.1 GHz, 2.0-2.35 GHz, 20dBm \$48.00

### Components

OPTOELECTRONICS from MITSUBISHI and SIEMENS

LASER DIODES 3 mw single mode CW, MITSUBISHI LASER DIODES, single mode 3mW, 830nm, 780nm Call  
IR LED - High efficiency 16 mW @ 100 mA LD271 \$ 0.75  
PIN PHOTODIODE - Large area, fast detector BPW34 \$ 3.00

RECTICON PROGRAMMABLE SWITCHED CAPACITOR AUDIO ACTIVE FILTER

No external R or C, 18 pin DIP, RS620 \$7.50 Ap. Notes \$ 2.00

MRF 901 Substitute 2SC2876, Ft=7GHz, 2.20dBNF @ 1GHz \$ 1.50

NEC 64535 direct replacement, Siemens BFD 74 \$ 9.20

LEADLESS DISK CAPS 100, 220, 470, 680, 1000 pF 10 for \$ 2.50

MICROWAVE CHIP CAPS - Very low loss VITRAMON P7800 series

GO2(0.7-1.4 GHz) GO4(1.3-2.6 GHz) GO1(2.6-4.2GHz) \$ 1.00

VITRAMON VHF/UHF NP0 chips: 10, 100, 1000 pF 5/ \$ 2.50

STRIPLINE SHUTTLE TRIMMERS (VOLTRONICS) 0.1, 2.5, 0.5, 9.0 pF \$ 3.19

H-O SEALED CERAMIC PISTON TRIMMERS (VOLTRONICS) 0.6-9.0 pF \$ 3.41

THERMOELECTRIC HEAT PUMPS: 19 Watt, 30x30mm, 8.6 volts \$ 21.00

1.6 Watt 4.6x4.6mm, 1.5 volts \$ 30.00

3M GX250 glass/epoxy board, Er=2.55 @ 100Hz 0.031 \$0.30/sq. in

0.062 \$0.50 sq. in

JOHNSON SMA's: Sq. flange female \$3.00, Male cable \$2.75

PROMPT SERVICE: SEND FOR CATALOG

MINIMUM ORDER \$5.00 ADD POSTAGE AND HANDLING

\* ITEMS (UPS) \$3.75 ALL OTHER ITEMS \$2.50 (FIRST CLASS)

NY STATE RESIDENTS ADD 6% SALES TAX

R.D.2 ROUTE 21 HILLSDALE, NY 12529

518-325-3911

Want a great Xmas gift?  
Leave this where your  
XYL will see it!



Give him a  
PERSONALIZED BINDER  
for his operations log!

Deluxe flexible vinyl with highly polished brass-plated corners, custom gold stamped with 1/8" high call letters, "Operations Log" and station owner's name in 1/8" type. Your choice of brown or milk vinyl base.

#H-144 3-ring binder for standard log sheets, 1" capacity

#H-548 Cover for spiral-bound ARRL log

Only \$36 plus \$3 handling/shipping.

MasterCard or VISA. Calif. residents add 6 1/2 %

H.N. LOCKWOOD, INC., 450 Maple St.  
Redwood City, CA 94063 • (415) 366-9557

## QUALITY VHF/UHF KITS AT AFFORDABLE PRICES

Call or Write for FREE CATALOG  
(Send \$1.00 or 4 IRC's for overseas mailing)  
See our two page ad in 73 Magazine



FM REPEATERS  
FM & AM RECEIVERS  
FM EXCITERS & XMTRS  
FM & SSB POWER AMPS  
RECEIVING & TRANSMITTING  
CONVERTERS FOR FM & SSB  
LOW-NOISE PREAMPS  
CWID's, COR's, RF TIGHT CASES  
HELICAL RESONATORS

For Repeaters, Links, OSCAR,  
ATV, Mobile, Base, Scientific

**hamtronics, inc.**

65-X MOUL RD. • HILTON NY 14468  
Phone: 716-392-9430

Hamtronics® is a registered trademark

- ★ Technical Forums
- ★ ARRL and FCC Forums
- ★ GIANT 2-day Flea Market  
Saturday and Sunday
- ★ New Products and Exhibits
- ★ Grand Banquet
- ★ Women's Activities
- ★ Home-Brew Equipment  
Forum
- ★ Special Group Meetings
- ★ YL Forum
- ★ Personal Computers Forum
- ★ CW Proficiency Awards
- ★ Amateur of Year Award
- ★ Special Achievement  
Awards

# DAYTON Hamvention®

**APRIL 29, 30, MAY 1, 1983**

Hara Arena and Exhibition Center — Dayton, Ohio

Meet your amateur radio friends from all over the world at the internationally famous Dayton HAMVENTION.

Seating will be limited for Grand Banquet and Entertainment on Saturday evening so please make reservations early. Banquet speaker is Bill Leonard, W2SKE, former president of CBS News.

If you have registered within the last 3 years you will receive a brochure in late February. If not write Box 44, Dayton, OH 45401.

Nominations are requested for Radio Amateur of the Year and Special Achievement Awards. Nomination forms are available from Awards Chairman, Box 44, Dayton, OH 45401.

For special motel rates and reservations write to Hamvention Housing, 1406 Third National Bldg., Dayton, OH 45402.  
**NO RESERVATIONS WILL BE ACCEPTED BY TELEPHONE.**

All other inquiries write Box 44, Dayton, OH 45401 or phone (513) 849-1720.

**Admission:** \$7.50 in advance, \$9.00 at door. (Valid for all 3 days)

**Banquet:** \$14 in advance, \$16 at door.

**Flea Market Space:** \$15 in advance. (Valid for both days)

Make checks payable to Dayton HAMVENTION, Box 2205, Dayton, OH 45401.

Bring your family and enjoy a great weekend in Dayton.

Sponsored by the Dayton Amateur Radio Association, Inc.

**DADE RADIO CLUB presents**  
1983  
**Southeastern Division Convention  
& 23rd Annual  
TROPICAL HAMBOREE**



**Flagler Dog Track  
Miami, Florida  
February 5-6, 1983**



**REGISTRATION:**  
\$3.00  
thru February 1st  
\$4.00  
after February 1st

**FREE PARKING**  
INCLUDING OVERNIGHT PARKING  
FOR SELF-CONTAINED RV UNITS  
(ADVANCE RV SPACE RESERVATION IS RECOMMENDED)

For further information write:  
DADE RADIO CLUB, INC.  
P.O. Box 350045, Riverside Station  
Miami, FL 33135

## ORLANDO'S HAMCATION '83

at the all new, air conditioned  
**EXPO-CENTRE**  
near I-4 & Hwy. 50, downtown

**March 18-19-20, 1983**

Fri. 5 - 10 p.m., Sat. 9 a.m. - 5 p.m.  
Sun. 9 a.m. - 2 p.m.

REGISTRATION \$5 advance, \$7 at door  
Under 14 free

For swap tables, commercial booths,  
advance registration or information,  
please send S.A.S.E. to:

Hamcation Chairman  
P.O. Box 191, DeBary, FL 32713

Hamfest headquarters at  
Howard Johnson's, Downtown  
I-4 & Hwy. 50

For special rates, mention 'HAMFEST'  
Call 305-843-8700 or mail  
reservation to  
304 W. Colonial Dr., Orlando 32802



# flea market



**RATES** Noncommercial ads 10¢ per word; commercial ads 60¢ per word **both payable in advance.** No cash discounts or agency commissions allowed.

**HAMFESTS** Sponsored by non-profit organizations receive one free Flea Market ad (subject to our editing) on a space available basis only. Repeat insertions of hamfest ads pay the non-commercial rate.

**COPY** No special layout or arrangements available. Material should be type-written or clearly printed (not all capitals) and must include full name and address. We reserve the right to reject unsuitable copy. **Ham Radio** cannot check each advertiser and thus cannot be held responsible for claims made. Liability for correctness of material limited to corrected ad in next available issue.

**DEADLINE** 15th of second preceding month.

**SEND MATERIAL TO:** Flea Market, Ham Radio, Greenville, N. H. 03048.

## QSL CARDS

**QSLs & RUBBER STAMPS** — Top Quality! Card Samples and Stamp Info — 50¢ — Ebbert Graphics 5R, Box 70, Westerville, Ohio 43081.

**TRAVEL-PAK QSL KIT** — Converts post cards, photos to QSLs. Stamp brings circular. Samco, Box 203-c, Wyanant-skill, New York 12198.

**QSL SAMPLES:** 25¢. Samcards, 48 Monte Carlo Drive, Pittsburgh, PA 15239.

**DISTINCTIVE QSL's** — Largest selection, lowest prices, top quality photo and completely customized cards. Make your QSL's truly unique at the same cost as a standard card, and get a better return rate! Free samples, catalogue. Stamps appreciated. Stu K2RZP Print, P.O. Box 412, Rocky Point, NY 11778 (516) 744-6260.

**QSL ECONOMY:** 1000 for \$13. SASE for samples. W4TG, Box F, Gray, GA 31032.

**QSL'S: NO STOCK DESIGNS!** Your art or ours; photos, originals, 50. for samples & details (refundable). Certified Communications, 4138 So. Ferris, Fremont, Michigan 49412.

## Foreign Subscription Agents for Ham Radio Magazine

Ham Radio Austria  
F. Bassl  
Hauptplatz 5  
A-2700 Wiener Neustadt  
Austria

Ham Radio Belgium  
Stereohouse  
Brusselssesteenweg 416  
B-9218 Gent  
Belgium

Ham Radio Canada  
Box 400, Goderich  
Ontario, Canada N7A 4C7

Ham Radio Europe  
Box 444  
S-194 04 Uplands Vasby  
Sweden

Ham Radio France  
SM Electronic  
20 bis, Ave des Clavions  
F-89000 Auxerre  
France

Ham Radio Germany  
Karin Ueber  
Postfach 2454  
D-7850 Loerrach  
West Germany

Ham Radio Holland  
Postbus 413  
NL-7800 Ar Emmen  
Holland

Ham Radio Italy  
G. Vulperti  
P.O. Box 37  
I-22063 Cantù  
Italy

Ham Radio Switzerland  
Karin Ueber  
Postfach 2454  
D-7850 Loerrach  
West Germany

Ham Radio UK  
P.O. Box 63, Harrow  
Middlesex HA3 6HS  
England

Holland Radio  
143 Greenway  
Greenside, Johannesburg  
Republic of South Africa

**WANTED:** Complete manual for RT662 by General Dynamics Electronics. Douglas Yumoto, (312) 677-3683 days or 677-8258 nights, Center Road, Skokie, IL 60077.

**HAM-AD-FEST** — Next 6 issues \$2.00. WA4OSR's Rigs & Stuff, Box 973-H, Mobile, AL 36601.

**AMATEUR RADIO COLLECTOR** newsletter. A must for historic ham collectors. 4 issues \$3.00. Radiographics, Box 18492, Cleveland Heights, OH 44118.

**WANTED:** Micor and Mstr II Base Stations 406-420 and 450-470 MHz. Also 2 and 6 GHz solid state microwave equipment. AK7B, 4 Ajax Place, Berkeley, CA 94708.

**AMAZING SECRET** to Amateur modification of CB radios. 80 through 6 meters. Inexpensive way to modify — free details — write: WA7QHY, PO Box 1361-H, Sandy, Utah 84091.

**CHASSIS** and cabinet kits. SASE K3IWK.

**VIDEOSCAN 1000** Slow Scan TV — High resolution (Amateur, phone line, surveillance, teleconferencing). Code\*Star — decode Morse, RTTY, ASCII. Large LEDs or connect computer/printer. Morse-A-Keyer — CW keyboard. Tri-voltage power supply. Kits/assembled. Free brochures. Microcraft Corporation, Box 513-HR, Thiensville, WI 53092. (414) 241-8144.

**ANTENNA TROUBLE ???** For \$5.00, Antenna Analyst, 40 Benefit Rd., Wakefield, R.I. 02879 will cure your headache, or refund your money.

**FOR SALE:** Ten-Tec Omni-D, \$475.00; Ten-Tec 315 Argonaut Receiver \$135.00; Ten-Tec 515 Argonaut \$300.00; Kenwood TR-7800 2m, \$290.00; Sony ICF-2001 digital sw/ftm, \$235.00; R-390A, exc. but blows fuses, w/ful set manuals, \$225.00; R392 w/manual, \$170.00; Panasonic R-to-R video recorder, \$100.00; Panasonic R-to-R portable video outfit, incl. recorder, camera, A.C.p.s./charger, \$180.00. WA7ZYQ (208) 245-2070.

**PRE-1946 TELEVISION SETS** wanted for substantial cash. Finder's fee paid for leads. Also interested in spinning disc, mirror-in-the-lid, early color sets, 9AP4 picture tubes. Arnold Chase, 9 Rushleigh Road, West Hartford, Conn. 06117 (203) 521-5280.

**PROFESSIONAL QUALITY** Ham Radio, QST circuit boards at ham prices. Catalog \$1.50 postpaid. Dynaclad Industries, Box 296, Meadowlands, PA 15347.

**RTTY AND ASCII** for Atari. Plans and a drilled PC board to build your own modem. ASCII and RTTY programs on disk all for \$25. Robert Holsti, K7ZJDKH2, Box 4426, AAFB Br. Yigo Guam 96912 (USA).

**ROHN TOWERS** — Wholesale direct to users. All Products Available. Write or call for price list. Also we are wholesale distributors for Antenna Specialists, Regency, Hy-Gain and Wilson. HILL RADIO, P.O. Box 1405, 2503 G.E. Road, Bloomington, IL 61701-0887. 309-663-2141.

**TUBES, TUBES** wanted for cash or trade. 304TL, 4CX1000A, 4PR60C, WE300, 7F7, 7N7, 53, 6L6M. Any high power or special purpose tubes of Eimac/Varian. DCO, 10 Schuyler Avenue, No. Arlington, NJ 07032. (800) 526-1270.

**MINIATURE PRECISION HAND TOOLS**, top of the line. Box joints, adjustable coil springs. Brown cushioned handgrips. Drop forged from the finest grain (1998) alloy steel. Hand polished with tempered cutting edges. Gripping edges are carefully machined to insure precision alignment. Example: Bent Flat-nose pliers, smooth jaws for precision assembly, looping and twisting in confined areas. Send for Free catalog. Skyline Products, 5205 Leesburg Pike, Dept. FM, Suite 202, Falls Church, VA 22041.

**EMBROIDERED EMBLEMS, ENAMELED PINS**, your design, low minimum. Informational booklet. Emblems, Dept. 65, Littleton, New Hampshire 03561. (603) 444-3423.

**SLEP SPECIALS:** Jennings UC5L-1000 variable vacuum capacitors, with gear drive train and mounting bracket, new boxed \$59.50, plug-ins for HP5245L counter, 5253B, 50-500 MHz \$95.00; 5261A \$69.00; 5262A \$69.00; 5245L service manual \$12.50. Tektronix 1L30 spectrum analyzer plug-in 925 MHz thru 10.5 GHz \$495.00; Tektronix 3S76 dual trace plug-in \$75.00; Marconi Instruments model TF1066B am/fm signal generator 10 MHz thru 470 MHz \$550.00. Jerrold 900A sweep generator \$275.00; Military TV-7/U tube tester \$45.00; Military TS-510/U signal generator 10 MHz thru 420 MHz, equivalent to HP608D \$375.00, all excellent lab test condition. Add shipping, we accept M/C, VISA or check. Phone 704-524-7519. Slep Electronics Company, Highway 441, Otto, NC 28763.

**DRAKE SATELLITE RECEIVER** with modulator installed only \$969. Satellite and Microwave TV catalog \$1.00. TEM Microwave, 22518 97th Ave. No., Corcoran, MN 55374 (612) 498-8014.

**SATELLITE TELEVISION INFORMATION.** Build or buy your own earth station. \$4.00 to Satellite Television, RD #3, Oxford, NY 13830. Parabolic antenna construction book also available. Send SASE for details.

## BUTTERNUT ELECTRONICS COMPANY



Model 2MCV "Trombone"  
Model HF6V  
Model 2MCV-5 "Super Trombone"

# THE WINNERS

Model HF6V — Completely automatic bandswitching 80 through 10 plus 30 meters. Outperforms all 4 and 5-band "trap" verticals of comparable size. Thousands in use worldwide since December 81! 160 meter option available now. retrofit kits for remaining WARC bands coming soon. Height: 26 ft/7.8 meters; guying not required in most installations.

Model 2MCV "Trombone" — omnidirectional collinear gain vertical for 2 meters having the same gain as "double-A" types, but the patented "trombone" phasing section allows the radiator to remain unbroken by insulators for maximum strength in high winds. No coils "plumber's delight" construction and adjustable gamma match for complete D.C. grounding and lowest possible SWR. Height: 9.8 ft/2.98 meters.

**NEW** Model 2MCV-5 "Super Trombone" — Same advanced features as the basic 2MCV but a full wavelength taller with additional "Trombone" phasing section for additional gain. Height: 15.75 ft/4.8 meters.

All BUTTERNUT ANTENNAS use stainless steel hardware and are guaranteed for a full year. For further information on these and other BUTTERNUT products write for our FREE CATALOG!

## BUTTERNUT ELECTRONICS

GARY AIRPORT BOX 356 E RTE 2  
SAN MARCOS, TEXAS 78666

**High Performance**

# vhf/uhf preamps

EME  
Scatter  
Tropo  
Satellite  
ATV  
Repeater  
FM Equipment  
Radio Telescope

**NEW GaAsFETs!**



	Freq. Range (MHz)	N.F. (dB)	Gain (dB)	1 dB Comp. (dBm)	Device Type	Price
P28VD	28-30	<1.1	15	0	DGFET	\$29.95
P50VD	50-54	<1.3	15	0	DGFET	\$29.95
P50VDG	50-54	<0.5	24	+12	GaAsFET	\$79.95
P144VD	144-148	<1.5	15	0	DGFET	\$29.95
P144VDA	144-148	<1.0	15	0	DGFET	\$37.95
P144VDG	144-148	<0.5	24	+12	GaAsFET	\$79.95
P220VD	220-225	<1.8	15	0	DGFET	\$29.95
P220VDA	220-225	<1.2	15	0	DGFET	\$37.95
P220VDG	220-225	<0.5	20	+12	GaAsFET	\$79.95
P432VD	420-450	<1.8	15	-20	Bipolar	\$32.95
P432VDA	420-450	<1.1	17	-20	Bipolar	\$49.95
P432VDG	420-450	<0.5	16	+12	GaAsFET	\$79.95

**Advanced Receiver Research**

Box 1242 • Burlington CT 06013 • 203 582-9409

Preamps are available without case and connectors: subtract \$10. Other preamps available in the 1-800 MHz range. Prices shown are postpaid for U.S. and Canada. CT residents add 7 1/4% sales tax. C.O.D. orders add \$2. Air mail to foreign countries add 10%.



**MOBILE IGNITION SHIELDING.** Estes Engineering, 930 Marine Dr., Port Angeles, WA 98362.

**RTTY-EXCLUSIVELY** for the Amateur Teleprinter. One year \$7.00. Beginners RTTY Handbook \$8.00 includes journal index. PO Box RY, Cardiff, CA 92007.

**WE WANT** your innovative, working antenna and ham product designs for development and marketing. Jon Titus (KA4QVK) Box 242, Blacksburg, VA 24060. (703) 951-9030.

**WANTED:** Buy or swap Model 28 paper winders (LPW 300). Top prices paid for complete units or parts. Call or write Van, W2DLT. In NJ 800-272-1331, outside NJ 800-526-3662. Box 217, Berkeley Hts., NJ 07922.

**MANUALS** for most ham gear made 1937/1970. Send \$1.00 for 18 page "Manual List", postpaid. HI-MANUALS, Box R802, Council Bluffs, Iowa 51502.

**SATELLITE TELEVISION** — Howard/Coleman boards to build your own receiver. For more information write: Robert Coleman, Rt. 3, Box 58-AHR, Travelers Rest, SC 29690.

**WANTED:** Schematics-Rider, Sams or other early publications. Scaramella, P.O. Box 1, Woonsocket, RI 02895-0001.

**WANTED:** Early Hallicrafter "Skyriders" and "Super Skyriders" with silver panels, also "Skyrider Commercial", early transmitters such as HT-1, HT-2, HT-8, and other Hallicrafter gear, parts, accessories, manuals. Chuck Dachis, WD5EOG, The Hallicrafter Collector, 4500 Russell Drive, Austin, Texas 78745.

**TELETYPE PARTS WANTED:** Any quantity, any models, highest prices paid. In NJ 800-272-1331, outside NJ 800-526-3662. Van, W2DLT, Box 217, Berkeley Hts., NJ 07922.

**SATELLITE TELEVISION:** Discount prices on all major TVRO items. Communications Consultants. (501) 452-3149.

**RUBBER STAMPS:** 3 lines \$3.25 PPD. Send check or MO to G.L. Pierce, 5521 Birkdale Way, San Diego, CA 92117. SASE brings information.

**WANTED:** New or used MS and coaxial connectors, synchros, tubes, components, military surplus equipment. Bill Williams, PO #7057, Norfolk, VA 23509.

**VERY in-ter-est-ing!** Next 5 issues \$2. Ham Trader "Yellow Sheets", POB356, Wheaton, IL 60187.

**CB TO 10 METER PROFESSIONALS:** Your rig or buy ours — AM/FM/SSB/CW. Certified Communications, 4138 So. Ferris, Fremont, Michigan 49412; (616) 924-4561.

**HAMS FOR CHRIST** — Reach other Hams with a Gospel Tract sure to please. Clyde Stanfield, WA6HEG, 1570 N. Albright, Upland, CA 91786.

**KTSB Multi-Band dipole 160-80M (WARC)** \$59.95, 2KW plus center connector w/SO239 \$8.50. Kilo-Tec, P.O. Box 1001, Oak View, CA 93022. (805) 646-9645.

**MOTOROLA ALL SOLID-STATE MOTRAN RADIOS.** Model X43LSN-2170, four frequency, transmit 150 MC (30W), receive 450 MC. Will operate in Ham Bands. No modification required. Large stock available. \$150.00 each. Omni Communications. Call (312) 852-0738.

**MOTOROLA VHF (2 meters) U43 Motran.** 4 channel all solid state. Omni Communications. Call (312) 852-0738.

## Coming Events ACTIVITIES "Places to go..."

**ILLINOIS:** Wheaton Community Radio Amateurs Hamfest will be held February 6, 1983 at Arlington Park Race Track EXPO Center, Arlington Heights, Illinois. Free Flea Market tables and plenty of floor space. Large commercial area including computer section. For general info call W9JTO at 311-231-9524. Clear paved parking. Awards. Tickets \$3.00 at entrance, \$2.50 in advance. Send SASE to WCRA, P.O. Box QSL, Wheaton, IL 60187. Talk-in on 146.01/61 and 146.94. Doors open 8 AM. Be There! — KA9KDC.

**INDIANA — SOUTH BEND:** Hamfest Swap & Shop, January 2, 1982, first Sunday after New Year's Day at Century Center downtown on U.S. 33 Oneway North between St. Joseph Bank Building and river. Industrial History Museum in same building. Carpeted half acre room. Tables \$3 each. Four lane highways to door from all directions. Talk-in freq: 52-52, 99-39, 93-33, 78-18, 69-09, 145.43, 145.29.

# WARNING

## SAVE YOUR LIFE OR AN INJURY

Base plates, flat roof mounts, hinged bases, hinged sections, etc., are not intended to support the weight of a single man. Accidents have occurred because individuals assume situations are safe when they are not.

Installation and dismantling of towers is dangerous and temporary guys of sufficient strength and size should be used at all times when individuals are climbing towers during all types of installations or dismantlings. Temporary guys should be used on the first 10' or tower during erection or dismantling. Dismantling can even be more dangerous since the condition of the tower, guys, anchors, and/or roof in many cases is unknown.

The dismantling of some towers should be done with the use of a crane in order to minimize the possibility of member, guy wire, anchor, or base failures. **Used towers in many cases are not as inexpensive as you may think if you are injured or killed.**

Get professional, experienced help and read your Rohn catalog or other tower manufacturers' catalogs before erecting or dismantling any tower. A consultation with your local, professional tower erector would be very inexpensive insurance.

**Paid by the following:**

**UNR-Rohn**  
Division of UNR, Inc.  
6718 West Plank Road  
Peoria, Illinois 61601  
USA

**LOUISIANA:** The Southeastern LA University and the Southeastern LA ARC are sponsoring a Hamfest on Saturday, January 15 on the SLU campus, Twelve Oaks Cafeteria from 9 AM to 3 PM. Free admission. Free swap tables.

**MICHIGAN:** The Southfield High School Amateur Radio Club's 18th annual Swap & Shop, January 30, Southfield High School, 24675 Lahser, Southfield, 8 AM to 3 PM. Admission \$2.50. Reserved tables \$18.00 in advance for two 8 ft. tables. All profits go toward electronic scholarships and to support the activities of Southfield HS Amateur Radio Club. For information/reservations: Robert Younker, Southfield High School, 24675 Lahser, Southfield, MI 48034. Telephone: (313) 354-7372, 8 AM to 10:30 AM; or (313) 354-8210 10:30 AM to 3 PM, Monday through Friday.

**VIRGINIA:** Richmond Frostfest '83. The annual winter Ham Radio and Computer Show will be held Sunday, January 16 at the State Fairgrounds, Richmond. General admission: \$4.00. All indoor flea market and commercial exhibits. Major prizes in HF and VHF equipment and a minicomputer. Sponsored by the Richmond Amateur Telecommunications Society, P.O. Box 1070, Richmond, VA 23208.

## OPERATING EVENTS "Things to do..."

**FEBRUARY 5:** New Hampshire QSO Party sponsored by the Concord Brassponders, Inc. Operating periods 1900Z February 5 to 0700Z February 6 and 1400Z February 6 to 0200Z February 7. 24 hours total. Awards mailing deadline March 12, 1983. Send your entry with large SASE for results and/or award to Concord Brassponders, Inc., c/o Norman W. Littlefield, RFD 1, Buck Street, Box 323, Suncook, NH 03275, W1JXB.

**JANUARY 15:** WD2ALL will operate the Camp Ballou Scout Freezeout from the Camp Ballou Boy Scout Camp; 1400 to 1700, 1800 to 2200, and 2300 to 0100 GMT. Frequencies 10 kHz above lower edge of General phone bands and 25 kHz above lower edge of Novice bands. Also 146.55 simplex operation is planned. QSL with SASE to WD2ALL via callbook.

**HAMFESTERS RADIO CLUB** is celebrating its 50th anniversary in 1983. Look for club station W9AA on all bands. We will send a special QSL card for contacts this anniversary year. QSL to: Hamfesters Radio Club, P.O. Box 42792, Evergreen Park, IL 60642.

**JANUARY 29:** The fifth annual *Freeze Your Arctic Off* sponsored by the Ford Tin Lizzy Club from 1700Z to 1700Z, January 29 and 30. Look for AD8R/8 on 7.275, 21.380 and 146.58. For a certificate QSL to Box 545, Sterling Heights, MI 48077.

**JANUARY 29:** The Eau Claire, WI, ARC will operate K9EC/9 during the National 70 meter Ski Jumping and Nordic Combined Championship from 1400Z to 2300Z, January 29 and 30. Frequencies: CW — 52 kHz up from bottom edge. Phone — 3980, 7277, 14282, 21382, and 28620. SASE for certificate to N9AIX, P.O. Box 201, Altoona, WI 54720.

**JANUARY 22:** The West Virginia QSO Party sponsored by the WV State Amateur Radio Council, 1700Z January 22 to 1700Z January 23. Single operator only. Suggested frequencies: Phone 10 kHz from lower edge of General sub-bands; CW 35 kHz from low ends; Novice 35 kHz from low ends. Repeater contacts permissible. Mail logs by February 11 to K8BS, 950 Gordon Road, Charleston, WV 25303.



### FREE CATALOG HARD-TO-FIND PRECISION TOOLS

Lists more than 2000 items: pliers, tweezers, wire strippers, vacuum systems, relay tools, optical equipment, tool kits and cases. Send for your free copy today!

**JENSEN TOOLS INC.**

7815 S 46TH STREET PHOENIX AZ 85040

### FACSIMILE

**COPY SATELLITE PHOTOS,  
WEATHER MAPS, PRESS!**

The Faxes Are Clear — on our full size (18-1/2" wide) recorders. Free Fax Guide

### TELETYPE

**RTTY MACHINES, PARTS, SUPPLIES**

ATLANTIC SURPLUS SALES (212) 372-0349  
3730 NAUTILUS AVE BROOKLYN, N.Y. 11224

## Your own satellite TV system for \$2388.<sup>00</sup> 10 FT. PARABOLIC

What the system will do:

You can receive up to 60 channels of T.V. direct from satellites to your home receiver. Movies, sporting events, religious programs, other T.V. stations, and much more.

What the system includes:

1. 10 ft. fiberglass dish made of reflective metal bond with fiberglass. Weather-resistant and virtually maintenance-free. Dish comes in 4 sections.
2. Single pedestal heavy duty polar mount for extra strength and installation simplicity; easy satellite to satellite adjustment.
3. Four pole rotator mount for more stability, square tube legs and rotator included.
4. All aluminum LNA mount and horn holder for accurate aiming of LNA. All aluminum, weather-proof LNA cover.
5. Drake ESR-24 Receiver or Auto-Tech Receiver. Your choice. Down converter located at the dish.
6. Amplica or Avanteck LNA 120°.
7. Chapparel Feed Horn for unsurpassed quality.
8. All accessories included.

Complete Systems, Receivers,  
Antennas, LNA's & Accessories  
CALL US TODAY! 901-795-4504

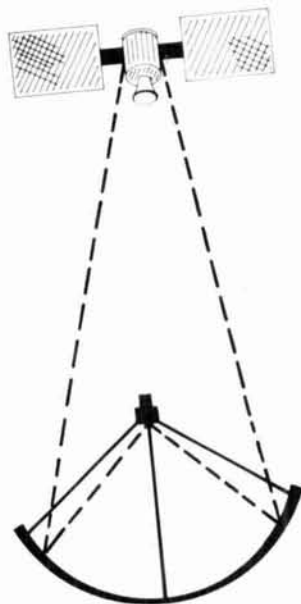

NEW WEST COAST SHIPPING WAREHOUSE

13 FT.

ALSO PARABOLIC  
DISHES

**TENNESSEE ELECTRONICS**  
— P.O. BOX 181108 —  
**MEMPHIS, TENNESSEE 38118**

Homebrew  
Headquarters



**KIT \$49.95**

Plus \$2.50 Shipping & Handling

**1982 CATALOG 50¢**

## "SMART" SQUELCH FOR SSB

73 MAGAZINE 8/82

Other Kits:

- R-X Noise Bridge (hr 2/77)
- General Coverage Reception Drake R-4C Receiver (QST 5/81)
- 2 Meter Converter (73 4/82)
- 40 Meter QRP Transceiver (hr 1/81)
- Fun-Mitter (73 2/81) Fun-Ceiver (73 7/81)
- Fun-Oscillator (73 2/82) Fun-Amp (73 5/82) and others

**RADIOKIT**

Box 411H, Greenville, NH 03048  
(603) 878-1033

## SYNTHESIZED SIGNAL GENERATOR

MADE IN  
USA



MODEL  
SG1000  
\$349.95  
plus shipping

- Covers 100 to 185 MHz in 1 kHz steps with thumb-wheel dial • Accuracy 1 part per 10 million at all frequencies • Internal FM adjustable from 0 to 100 kHz at a 1 kHz rate • Spurs and noise at least 60 dB below carrier • RF output adjustable from 5-500 mV at 50 ohms • Operates on 12 Vdc @ 1/2 Amp • Available for immediate delivery • \$349.95 plus shipping
- Add-on Accessories available to extend frequency range, add infinite resolution, voice and sub-audible tones. AM, precision 120 dB calibrated attenuator
- Call for details • Dealers wanted worldwide

**VANGUARD LABS**

196-23 Jamaica Ave., Hollis, NY 11423  
Phone: (212) 468-2720

## ALL BAND TRAP ANTENNAS!

PRETUNED - ASSEMBLED ONLY ONE NEAT SMALL ANTENNA FOR ALL BANDS! EXCELLENT FOR APARTMENTS! IMPROVED DESIGN!

FOR ALL MAKES AMATEUR TRANSCEIVERS! GUARANTEED FOR 2000 WATTS SSB INPUT FOR NOVICE AND ALL CLASS AMATEURS!

COMPLETE with 90 ft. RG58U-52 ohm feedline, and PL259 connector, insulators, 30 ft. 300 lb. test dacron end supports, center connector with built in lightning arrester and static discharge - Low SWR over all bands - Tuners usually NOT NEEDED! Can be used as inverted V's - slopers - in attics, on building tops or narrow lots. THE ONLY ANTENNA YOU WILL EVER NEED FOR ALL BANDS! NO BALUNS NEEDED!

80-40-20-15-10 -- 2 trap - 104 ft. - Model 998BUC \$89.95  
40-20-15-10 -- 2 trap -- 54 ft. - Model 100BUC - \$89.95  
20-15-10 meter - 2 trap - 26 ft. - Model 1007BUC - \$87.95

SEND FULL PRICE FOR POSTPAID INSURED DEL. IN USA (Canada is \$5.00 extra for postage - clerical - customs etc.) or order using VISA - MASTER CARD - AMER EXPRESS. Give number and ex. date: Ph 1-308-236-5333 9AM - 6PM week days. We ship in 2-3 days. ALL PRICES MAY INCREASE SAVE - ORDER NOW! All antennas guaranteed for 1 year; 10 day money back trial if returned in new condition! Made in USA. FREE INFO. AVAILABLE ONLY FROM

WESTERN ELECTRONICS  
Dept. AR-1 Kearney, Nebraska, 68847



## surge protection and master control

Alpha Delta Communications has introduced the new Master AC Control Console (MACC) which features power surge protection and centralized control of several components. The MACC unit plugs into a single outlet, providing eight plug-in grounded outlets of its own — one hot, for a continuously powered application such as a clock and seven for individually controllable components.

The front panel has rocker switches for the individually controllable components, plus a master control rocker which allows the entire system to be turned on or off. Rockers are lit when on.

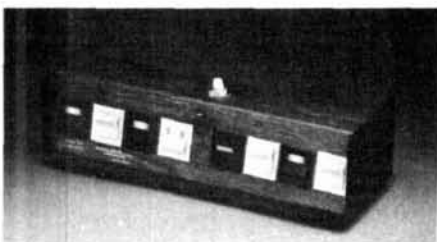

Alpha Delta's MACC uses three-stage automatically restorable circuitry to clip off power spikes and surges, and has a manually resettable circuit breaker for further protection. MACC is tested to IEEE pulse standards and rated at 15 amperes, 125 Vac, 60 Hz, 1875 watts continuous-duty total for the console.

MACC is priced at \$79.95. For more information, contact Alpha Delta Communications, P.O. Box 571, Centerville, Ohio 45459.

## X-Panda-Five

The X-Panda-Five makes your Hustler (or equivalent) into a five-band mobile antenna, with the appropriate coils added. When the X-Panda is installed with the proper resonators, you can change bands without stopping your vehicle. Each resonator, tuned to the desired frequency, eliminates the need for an antenna tuner.

Also, the X-Panda-Five adapter added to the Hustler or Hy-Gain antenna with the appropriate resonators and added ground planes will make an ideal antenna system for apartment houses and condominiums. It can also be used to make a multi-band antenna system for vans, campers, motor homes, and travel trailers.

The X-Panda-Five will accept either regular or super-size resonators. For further information, contact JL Industries, P.O. Box 030413, Ft. Lauderdale, Florida 33303.

## new TS830, TS930, R820 filter kit

Fox Tango Corporation announces a special high-quality matched-filter kit designed to significantly improve the selectivity of the Kenwood R820, TS830, and the new TS930 series. The Fox Tango filters (both 8-pole discrete crystal units instead of the original monolithic and ceramic types) each have a bandwidth of 2.1 kHz (net bandwidth of 1.99 kHz); a combined shape factor of 1.19; and an ultimate rejection greater than 110 dB. VBT may be used to narrow the operating i-f bandwidth to reduce QRM, (narrower bandwidths, usually given at -6 dB, help reduce adjacent channel interference) but the steepness of the filter skirts or shape factor (-60 dB BW divided by -6 dB BW) and their depth (ultimate rejection) are more important. If VBT is used to reduce the bandwidth to 1.99 kHz (to equal that of the FT filters without VBT), the shape factor of the original filters becomes 1.45 as compared

with 1.19 — and the ultimate rejection is less than 80 dB as compared with more than 110 dB — both significant differences.



Regardless of the type of filters, the use of VBT in these receivers always reduces the shape factor. With VBT off, the characteristic curves of the two filters essentially coincide with one another, referred to as filter cascading. The combined shape factor is usually better than that of either of the two filters involved. When VBT is used, one filter characteristic is made to slide with respect to the other, and only the portion where they overlap represents the bandpass area. The cascading effect is lost and the resulting characteristic has the skirt of the first filter on one side and that of the second on the other.

Also, because of the rounded shoulders of the original filter characteristics, the overlap at narrower bandwidths has the effect of increasing the filter insertion loss: 5 dB versus 0 dB with FT filters at 500 Hz bandwidth; 10 dB versus 1 dB with FT filters at 300 Hz. The greater such losses, the lower the receiver sensitivity in the CW mode. The superior characteristics of the FT filters results in excellent performance in both the SSB and CW modes practically eliminating the need for the purchase of optional CW filters by all but the most serious CW operators.

There are significant advantages in not buying any CW filters. In addition to saving the cost of the CW filters, installation is simplified since the FT matched pair can be inserted directly

into the holes provided for the CW filters. With this arrangement, the following operating options become possible: (1) FT filters for both RX and TX; (2) FT for RX, original Kenwood for TX; (3) FT for RX, switch-select FT or Kenwood for TX; (4) Switch-select FT or Kenwood for RX/TX. If CW filters have been (or are to be) used, the recommended arrangement is to replace the original SSB filters with the FT 2.1 matched pair. In this case only option 1 is possible. This installation is easy, no drilling or switching is required, and all parts are provided in the kit.

The matched pair filter kit, complete with detailed instructions, two 2.1 kHz Fox-Tango filters (guaranteed for one year), and all needed cables and parts is offered at an introductory price of \$150 plus \$3 for shipping (\$5 for air). Send your order, specifying the rig with which the filters are to be used, to Fox Tango Corporation, P.O. Box 15944, W. Palm Beach, Florida 33406, or order by telephone: 305-683-9587.

## 450-MHz handheld

A second cousin to the popular IC-2/3A series, the IC-4AT provides coverage of the 440-MHz band. It is identical in appearance, size and operational features to the popular IC-2A/3A series. All accessories, including battery packs, chargers, microphone, etc., are completely compatible with the IC-2AT and IC-3AT series. The IC-4AT also includes a sixteen-button Touchtone® pad.

The IC-4A covers the 440-MHz band from 440.0 MHz to 449.995 MHz and is set up for both duplex and simplex operation. The power output is nominally 1.5 watts with the standard IC-BP3. The IC-4A system will come complete with IC-BP3 Ni-Cd battery pack, wall charger, belt clip, rubber duckie, and wrist strap. The IC-4A costs \$269 and the IC-4AT is \$299.

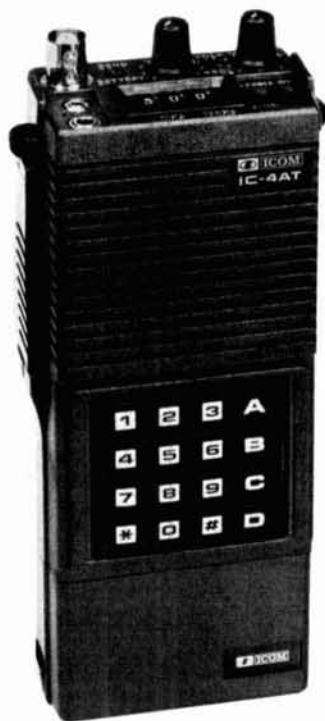

For more information, contact ICOM America, Inc., 2112 116th Ave. N.E., Bellevue, Washington 98004; telephone 206-454-8155.

## universal programmable filter

Applied Invention has introduced Reticon R5620, a universal programmable active filter. The R5620 is a complex NMOS switched capacitor active filter (SCF) analog IC. It uses switched capacitor technology to synthesize a two-pole pair active filter that requires no external components and operates over the range of 0.05 Hz to 25 kHz. The five basic filter types — lowpass, highpass, bandpass, band reject, and all pass — can be used as well as a programmable sine-wave oscillator. The Q is set to one of thirty-two approximately logarithmically spaced values from 0.57 to 150 by five control pins (hard-wired or TTL/MOS logic levels). Center frequency is set by an external clock oscillator. The clock division ratio can



**The HAM SHACK**

808 N. Main  
Evansville, IN 47711

<b>AEA</b>	
MBA-RO Reader	\$269.00
MBA-RC Rcv/Code Conv. Xmt	395.00
MM-2 MorseMatic Ultimate Keyer	150.00
CK-2 Contest Memory Keyer	125.00
KT-2 Keyer/Trainer	99.00
BT-1 Trainer	72.00
Isopole 144/220 MHz	40.00
<b>ARRL</b>	
83 Handbook	\$12.00
Antenna Book	8.00
License Manual	4.00
Large Assortment of Publications	call
<b>ASTRON</b>	
RS7A 5-7 Amp Power Supply	\$49.00
RS12A 9-12 Amp Power Supply	69.00
RS20A 16-20 Amp Power Supply	89.00
RS20M 16-20 Amp w/meter	109.00
RS35A 25-35 Amp	135.00
RS35M 25-35 Amp w/meter	149.00
RS50A 37-50 Amp	199.00
RS50M 37-50 Amp w/meter	225.00
<b>AZDEN</b>	
PCS 4000 2M Xcvr	call
PCS 300 Handheld	\$285.00
Most Accessories in Stock	
<b>BASH</b>	
Code Tapes/Study Guides	\$9.95
<b>BENCHER</b>	
BY-1 Paddle	\$36.00
BY-2 Chrome Paddle	45.00
<b>CALLBOOK</b>	
U.S.	\$19.95
DX	18.95
Map Library	4.50
<b>DAIWA</b>	
CNA-1001 0.5KW Antenna Tuner	\$299.00
CN 520 1.8-60 MHz SWR/Pwr Mtr	63.00
CN 620B 1.8-150 MHz SWR/Pwr Mtr	110.00
<b>DENTRON</b>	call for prices
<b>DRAKE</b>	
TR7A Xcvr	\$1,439.00
R7A Receiver	1,399.00
TR5 Xcvr	695.00
RV75 VFO	269.00
<b>ENCOMM (SANTEC)</b>	
ST-144/P	\$285.00
ST-440/P	309.00
Base Charger	29.95
All Accessories in Stock	

**HAL DAY**  
Saturday, January 22nd very special pricing  
Call for details.

<b>ICOM</b>	
R70 General Coverage Receiver	call
720A General Coverage Xcvr	\$1,140.00
730 Xcvr	669.00
740 Xcvr	call
251A 2 Meter All Mode	575.00
505 6 Meter Xcvr	395.00
25A 2 Meter	299.00
290H 2 Meter All Mode	475.00
35A 220 MHz Mobile	call
45A 440 MHz Mobile	call
2AT/3AT/4AT Handhelds	235.00
<b>KANTRONICS</b>	
Interface	\$165.00
Mini-Reader Pkg	225.00
Mini-Terminal	249.00
<b>MFJ</b>	
941C Tuner	\$81.00
496 Super Keyboard	279.00
313 VHF Conv. for 2 M HTs	36.00
104 New 24 hr. Dual Clock	36.00
Large Assortment	call
<b>MIRAGE</b>	
B1016	\$239.00
B3016	205.00
MP1/MP2 Watt Meters	100.00
<b>ROBOT</b>	
400 SSTV Converter	call
800 ASCII/Baudot/CW Terminal	call
<b>SHURE</b>	
444D Desk Mic	\$50.00
414A Hand Mic	36.00
<b>TEN-TEC</b>	
New Transceiver. Call about this one!	
<b>TOKYO HY-POWER</b>	
HL32V 25W Amp	\$75.00
HL82V 80W Amp	155.00
HL160V 160W Amp	285.00
HL20U 440 MHz Amp	105.00
HC150 Tuner	90.00
HC2000 Tuner	285.00
<b>VOCOM</b>	
Amplifiers/Ants	call

Prices and availability subject to change.



**812-422-0231**

MON-FRI 9AM-6PM • SAT 9AM-3PM

Send SASE for our new & used equipment list.

# PB RADIO

1950 E. Park Row Arlington, Texas 76010

★ SPECIALIZING IN: ★  
MDS Receivers & UHF Decoders

MDS COMPLETE COMMERCIAL UNIT.....\$169.95  
MDS SLOTTED ARRAY ANTENNA KIT.....\$25.00  
MDS DOWN CONVERTER KIT.....\$28.50  
MDS COMPLETE POWER SUPPLY.....\$35.00  
\*SPECIAL NE64535 TRANSISTORS.....\$6.50

UHF DECODERS: FV 3 INSTRUCTIONS.....\$5.00  
FV 3 BOARD \$30.00 FV 3 IC CHIP KIT \$50.00  
ZENITH 9-151-03 TUNER.....\$79.95  
BOX \$19.95 DELUXE BOX \$24.95  
POWER SUPPLY KIT.....\$24.95  
EDGE CONNECTORS.....\$2.95

SATELLITE T.V. SYSTEMS: PRODELIN DISHES, DEXCEL  
RECEIVERS, LNA'S & CHAPARRAL POLAROTORS. SEND \$1.00  
FOR MORE INFORMATION.

INFORMATION CALL 817-460-7071  
ORDERS ONLY CALL 800-433-5169



be varied from 50 to 200 (two octaves) in logarithmic steps.

Switched capacitor filters are simply standard analog filters with fixed resistors replaced by time division variable-switched capacitors. This results in a highly stable filter which can be accurately tuned with only a variable clock source. The programmability of the SCF makes it very attractive for microcomputer-controlled synthesizers and other analog/digital system applications. Small quantity price of the Reticon R5620 is \$8.00, with an application package available for an additional \$2.00. Contact Applied Invention, RD2, Route 21, Hillsdale, New York 12520; telephone 518-325-3911.

## new PC handbook

A new 40-page *Printed Circuit Handbook and Accessories Catalog* from GC Electronics, a division of Household International, features step-by-step instructions and diagrams and explains in careful detail how to produce professional-quality printed circuit designs.

This latest handbook is an enlarged and more complete version of the company's previous edition. It includes a variety of helpful information on how to produce both single and double sided printed circuit boards as well as PC specifications and trouble shooting tips. In addition, it pictures and describes more than 125 GC products.

Copies of the new *PC Handbook* (Cat. No. 22-100-HB) are now avail-

Finally...A 12-volt panel that will charge ALL your 12 and 9 volt batteries for under \$50.00

4.37 Watt  
Photovoltaic Battery  
Charger  
\$49.95

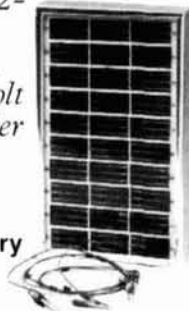

Maximum output 17.5 v.  
Amperage 250 mA  
Size 5 1/4" X 10"

- Space quality silicon cells
- Anodized aluminum frame
- Silicone encapsulation
- One plug, universal cord
- Blocking diode

Order direct from:

INTERNATIONAL SOLAR  
PRODUCTS CORPORATION

1105 W. Chapel Hill St.  
Durham, N.C. 27701  
(919) 489-6224

NEW! NEW! NEW!

## RADIO ELECTRONICS BUYERS GUIDE



A Guide To  
Radio and Electronic Parts  
Sold By  
Retail Mail Order

Have you ever wanted to build something but did not know where to find all of the parts? The Radio Electronics Buyers Guide lists where you can buy over 2500 kinds of parts from over 50 suppliers. Lists antenna parts, analog, digital, microwave components, mechanical hardware, etc., and the address and phone number of each supplier so you can contact them immediately. Make your construction projects more enjoyable by locating the parts you want. \$3.95 postage paid.

HALLWARD PRODUCTS  
39 Sunset Ct., St. Louis, MO 63121

## R-4C+SHERWOOD CRYSTAL FILTERS STILL THE FINEST COMBINATION

600 HZ LOW LOSS 1st IF CW FILTER. Improve early stage selectivity. Eliminate high-pitched leakage around 2nd IF filters. Improve ultimate rejection to 140 dB. Eliminate strong signals overloading 2nd mixer, causing intermod and desensitization. CF-600/6: \$80.00. New PC board relay switch kit: \$45.00.

1st IF SSB FILTERS. 140 dB ult. rej. CF 2K/8: \$150.00 pair. 5KHz 1st IF FILTER. Reduces hi-pitched QRM. CF-5K/8: \$80.00.

16-POLE R-4C SSB! Plug-in filter. Unexcelled skirt selectivity. 1800 Hz at 6 dB, 2400 Hz at 60 dB. CF 2K/16: \$135.00.

250, 500 and 1000 Hz 8-POLE 2nd IF PLUG-IN FILTERS. CF 250/8: \$80.00 and CF 1.0K/8: \$80.00.

PC Board mod. and switching kits. Special AM filters/detector. Filters also for R4 (B), R7, TR7, TR4, Signal/One, Atlas.

Add \$3 shipping per order; \$6 overseas air.

Europeans: Ingomper, Postfach 24 49, D-8070, Ingolstadt, W. Germany.

Sherwood Engineering Inc.

1268 South Ogden St.  
Denver, Colo. 80210  
(303) 722-2257



**GC Printed Circuit Handbook & Accessories**

**INTRODUCTION** 1  
 Linear Driver 2  
 Transmitter 3  
 Receiver 4  
 Antenna 5  
 Power Supply 6  
 Grounding 7  
 Shielding 8  
 Enclosure 9  
 PCB Specifications 10  
 Component Selection 11  
 Assembly 12  
 Testing 13  
 Troubleshooting 14  
 Safety 15  
 Index 16

**PRODUCT SECTION** 17  
 Product Section 17  
 Product Section 18  
 Product Section 19  
 Product Section 20  
 Product Section 21  
 Product Section 22  
 Product Section 23  
 Product Section 24  
 Product Section 25  
 Product Section 26  
 Product Section 27  
 Product Section 28  
 Product Section 29  
 Product Section 30  
 Product Section 31  
 Product Section 32  
 Product Section 33  
 Product Section 34  
 Product Section 35  
 Product Section 36  
 Product Section 37  
 Product Section 38  
 Product Section 39  
 Product Section 40  
 Product Section 41  
 Product Section 42  
 Product Section 43  
 Product Section 44  
 Product Section 45  
 Product Section 46  
 Product Section 47  
 Product Section 48  
 Product Section 49  
 Product Section 50  
 Product Section 51  
 Product Section 52  
 Product Section 53  
 Product Section 54  
 Product Section 55  
 Product Section 56  
 Product Section 57  
 Product Section 58  
 Product Section 59  
 Product Section 60  
 Product Section 61  
 Product Section 62  
 Product Section 63  
 Product Section 64  
 Product Section 65  
 Product Section 66  
 Product Section 67  
 Product Section 68  
 Product Section 69  
 Product Section 70  
 Product Section 71  
 Product Section 72  
 Product Section 73  
 Product Section 74  
 Product Section 75  
 Product Section 76  
 Product Section 77  
 Product Section 78  
 Product Section 79  
 Product Section 80  
 Product Section 81  
 Product Section 82  
 Product Section 83  
 Product Section 84  
 Product Section 85  
 Product Section 86  
 Product Section 87  
 Product Section 88  
 Product Section 89  
 Product Section 90  
 Product Section 91  
 Product Section 92  
 Product Section 93  
 Product Section 94  
 Product Section 95  
 Product Section 96  
 Product Section 97  
 Product Section 98  
 Product Section 99  
 Product Section 100

# LUNAR PUTS YOU THROUGH!

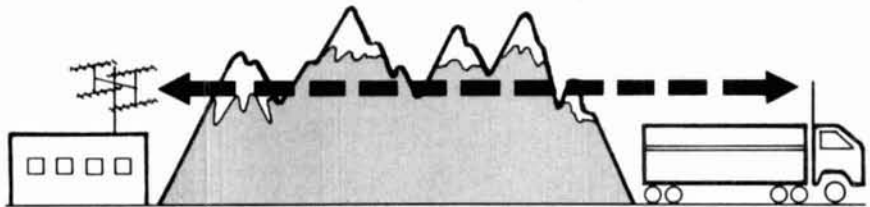

LUNAR'S LINEARIZED AMPS AND PREAMPS SUBSTANTIALLY IMPROVE THE OUTPUT POWER OF YOUR MOBILE AND FIXED STATIONS PLUS IMPROVE BASIC RECEIVER SENSITIVITY.



- Amplifiers have pre-amps built into a single package.
- Being Linearized, they accept all modes: SSB, AM, FM, etc.
- Will function with lower than rated drive. Eg.: Lunar 30 W amp can be used with 5 watt

handheld in emergencies.



Write for complete literature.

2775 Kurtz St., Suite 11, San Diego, CA 92110-3171 • (619) 299-9740 • Telex 181747

## simplex/duplex autopatch model

Current Development Corporation announces the Novax II Mobile Connection for interfacing radios to DTMF (TouchTone) and rotary dial telephones. In addition to the standard features of Novax I, the Novax II offers a four-digit access code; LED display; toll restrict; repeater use; and interfaces to rotary dial systems (for rotary dial telephones). Both units use a high speed switching technique that eliminates voice-activated switching problems.



For more information contact Current Development Corporation, Box 162, Tudman Road, Westmoreland, New York 13490; telephone 315-829-2785.

## ISOTRON ANTENNAS THE BEST THINGS come in little packages... FOR 80-40-20-15 METERS



ISOTRON 80 54 IN.HIGH	ISOTRON 40 31 IN. HIGH	ISOTRON 20 17 IN. HIGH
<b>BIG ON PERFORMANCE</b>		
<b>SMALL ON SPACE</b>		
<b>*BILAL COMPANY</b>		
(303) 687-3219		
STAR ROUTE 2	EUCHA, OK 74342	

### QUALITY SPECIALS

#### SOPHISTICATED I.C.'S

DATA SHEETS AND APPROPRIATE APPLICATION NOTES ARE PROVIDED FREE WITH ALL INTEGRATED CIRCUITS LISTED BELOW

PART # & MANUF.	DESCRIPTION	PRICE (ea.)
RD014 (LSI COMP. SVE)	CMOS DIVIDER I.C. HAS TRUTH-TABLE SELECTABLE INPUT TO YIELD DIVIDE BY 10, 100, 1000 OR 10000 OUTPUTS.	\$ 3.50
LS701	D.C. TO 5MHz SIX DECADE MOD UP COUNTER WITH 8 DECADE LATCH AND MULTIPLEXED BCD OUTPUTS AND DIGIT STROBE. ACCESS TO LATCHES ALLOWS ATTACHMENT OF PRESCALERS FOR COUNTING TO 500MHz.	\$13.75
LS720 (LSI COMP. SVE)	14 PIN DIP AUTOMOTIVE/MARINE ANTI-THEFT DIGITAL LOCK CIRCUIT HAS 5-DIGIT 4-DIGIT COMBINATIONS WITH 25 MICROAMP STANDBY 'SAVE' MODE FOR VALET PARKING.	\$ 3.50
ZN406 (FERRANTI)	3-DIGIT DIGITAL MULTIMETER I.C. WITH LCD DRIVE, ON CHIP CLOCK AND REFERENCE. A COMPLETE DMM CIRCUIT CAN BE MADE WITH 8 PASSIVE EXTERNAL COMPONENTS.	\$14.25
FED08D (AND CORP.)	3-DIGIT LCD DISPLAY	\$12.00
TSC726 (TELETYPE)	3-DIGIT A/D CONVERTER, LCD DRIVER DESIGNED FOR LOW POWER APPLICATIONS (DRIVE WITH A 9V BATTERY EQUIVALENT) TO INTERNAL 726.	\$16.95

#### CAPACITORS

DIPPED TANTALUMS	100 (ea.)	COMPUTER GRADE	100 (ea.)
1 mfd 35v	\$ 35	2.250	100
33mfd 35v	30	4.000	50
1 mfd 50v	30	12.000	50
1.5 mfd 20v	30	25.000	40
2.2 mfd 15v	30	27.000	30
6.8 mfd 25v	30	53.000	25
68 mfd 10v	80	180.000	20

AXIAL ELECTROLYTICS	1-100 (ea.)	100 (ea.)	RADIAL ELECTROLYTICS	1-100 (ea.)	100 (ea.)
1 mfd 50v	\$ 15	\$ 12	2.2mfd 25v	\$ 15	\$ 12
1.5mfd 25v	15	12	4.7mfd 35v	15	12
4.7mfd 15v	15	12	33 mfd 25v	15	12
10 mfd 50v	17	14	47 mfd 15v	15	12
47 mfd 25v	17	14	220 mfd 25v	15	12
150 mfd 10v	17	14	330 mfd 35v	20	15
220 mfd 10v	27	20	470 mfd 25v	25	27
470 mfd 25v	50	40	800 mfd 20v	35	27
1000 mfd 25v	70	50	1000 mfd 25v	70	50
2000 mfd 10v	80	60	2000 mfd 10v	75	50
2000 mfd 40v	85	60	3300 mfd 10v	75	50

#### MISCELLANEOUS

DESCRIPTION	PRICE (ea.)
28 PIN S.T. LOW PROFILE I.C. SOCKETS (TIN PLATED)	\$ 1.40
40 PIN S.T. LOW PROFILE I.C. SOCKETS (TIN PLATED)	\$ 1.55
1K or 25K SLIDE POTENTIOMETERS	\$ 1.75
250 OHM HORIZONTAL TRIM POT	\$ 1.80
1 MEG OHM HORIZONTAL TRIM POT	\$ 1.90
220 KILOHM HORIZONTAL TRIM POT	\$ 1.80
POWER LINE FILTER (SURPLUS) 1 AMP, 250VAC, 50/60HZ	\$5.00
POWER LINE FILTER (SURPLUS) 10 AMP, 115/250V, 50/60HZ	\$8.50

### GOLDSMITH SCIENTIFIC CORPORATION

P.O. BOX 318, COMMACK, NY 11725  
 PHONE ORDERS WELCOME—(516) 979-7944  
 MINIMUM ORDER \$10.00—U.S. FUNDS ONLY  
 NEW YORK STATE RESIDENTS ADD SALES TAX  
 POSTAGE—ADD 5% PLUS \$1.50 INSURANCE, C.O.D. \$2.00 EXTRA  
 AVAILABILITY OF CERTAIN ITEMS MAY BE LIMITED.

# SURPLUS VALUES

## NEW HT LEATHER CASES

Great For Amateur Handhelds Too!

These are new Motorola leather cases that were not quite finished at the factory. Most cases still need belt loops and snap fasteners for flap cover. We'll provide you with 2 flaps so you can sew or rivet on your own belt loop and cover.



**\$8.50** ea.  
plus UPS

ORDER BY STYLE

- AA HT-220 Slim, PL
- BB MT-500 Icom, Ken-wood, Yaesu
- CC HT-220 Slim, CS

5 Styles Available



**SPECIAL**  
**\$178.00** ea.



MOTOROLA MARK 12 UHF  
12 FREQ. PL, 20 WATTS  
ONE ELEMENT INCLUDED.  
WITH ACCESSORIES.

**50uA METERS!** \$7.00 ea.  
Various Scales plus UPS



SUPER DEAL ON PRODUCTION - REJECT 50uA METER MOVEMENTS. METERS ARE MARKED AS TO PROBLEM: "STICKY NEEDLES", "FOREIGN MATERIAL", "WRONG IMPEDANCE", ETC. MOST PROBLEMS CORRECTABLE WITH A LITTLE TIME. AT THE PRICE OF 50uA MOVEMENTS THESE DAYS. HOW CAN YOU GO WRONG?

**SPECIAL**  
**5 DIFFERENT SCALES (OUR CHOICE)**  
**\$30.00** plus shipping



**\$55.00**  
10 FOR \$450.00

### TSN6009A SIREN SPEAKER

TSN6009A SIREN SPEAKER 75W RATING WEATHER PROOF WIDE ARC FIBRE GLASS HORN CURRENT LIST \$152.48 SPECSPECIAL

**KRYLON**  
**CRYSTAL CLEAR**



**3 for \$5.00**  
13 OZ. SPRAY CAN  
STOCK NO. 1302 FOR  
ELECTRONIC USES.

**LAMDA**  
**POWER SUPPLY**



12 VDC. ADJUSTBL 2A  
LAB GRADE - NEW  
**\$30.00** ea.



**PT-200/300**  
**NICADS!**

NLN6267A NICAD BATTERY  
14 VOLT 1000 MAH  
USED IN PT 200/300  
**\$25.00** EA.  
4 FOR \$89.00

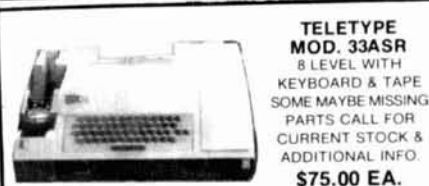

**TELETYPE**  
**MOD. 33ASR**  
8 LEVEL WITH  
KEYBOARD & TAPE  
SOME MAYBE MISSING  
PARTS CALL FOR  
CURRENT STOCK &  
ADDITIONAL INFO.  
**\$75.00** EA.



ALL PRICES DO NOT INCLUDE FREIGHT  
UPS BROWN RATES APPLICABLE FOR  
ITEMS 50LBS. OR LESS  
TRUCK RATES OVER 50 LBS. COLLECT

MINIMUM ORDER \$10.00

SEND S.A.S.E. (37¢ POSTAGE PLEASE) FOR OUR  
LATEST SURPLUS FLYER.



**SPECTRONICS** INC.  
1009 GARFIELD ST. OAK PARK, IL. 60304

PHONE  
**(312) 848-6777**





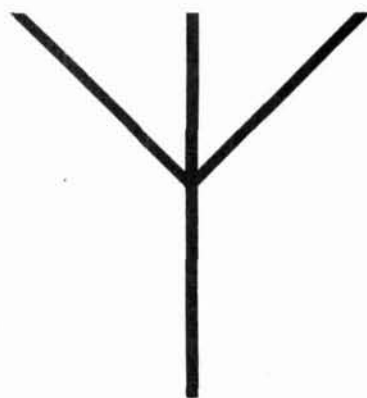

# BOOKS

**"A STATION IS ONLY AS EFFECTIVE AS ITS ANTENNA SYSTEM"**

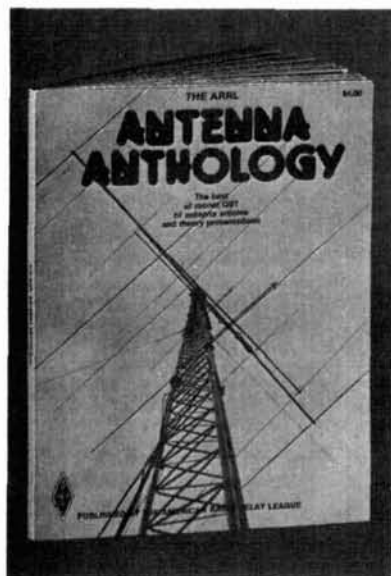
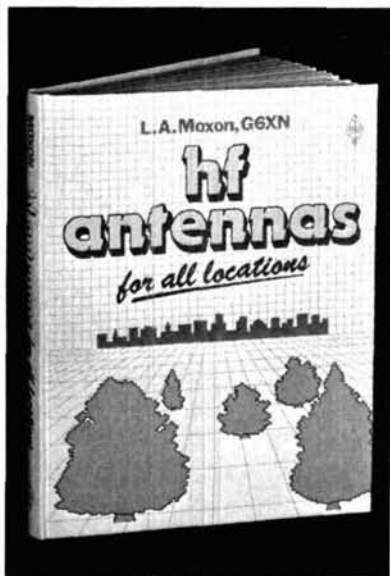
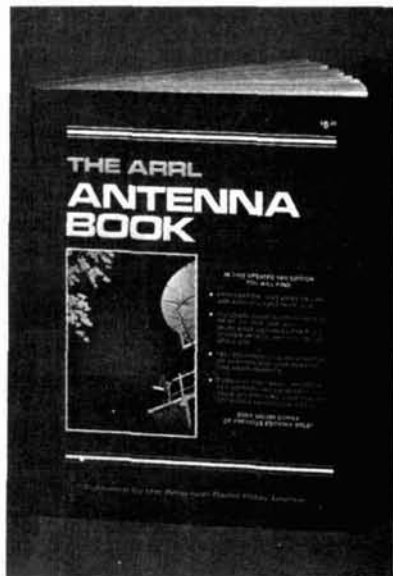

**THE ARRL ANTENNA BOOK** The best and most up-to-date antenna information around. The just revised 14th Edition contains in its 328 pages propagation, transmission line and antenna fundamentals. You can update your present antenna system with practical construction details of antennas for all amateur bands - 160 meters through microwaves. There are also antennas described for mobile and restricted space use. Tells how to use the Smith chart for making antenna calculations and covers test equipment for antenna and transmission line measurements. Over 600,000 copies of previous editions sold. Paperbound. Copyright 1982. \$8.00 in the U.S., \$8.50 elsewhere.

**HF ANTENNAS FOR ALL LOCATIONS** by L.A. Moxon, G6XN. An RSGB publication. Contains 264 pages of practical antenna information. This book is concerned primarily with small wire arrays, although construction information is also given on a small number of aluminum antennas. Chapters include: Taking a New Look at hf Antennas; Waves and Fields; Gains and Losses; Feeding the Antenna; Close-spaced beams; Arrays, Long Wires, and Ground Reflections; Multiband Antennas, Bandwidth; Antenna Design for Reception; The Antenna and Its Environment; Single-element Antennas; Horizontal Beams; Verticle Beams; Large Arrays; Invisible Antennas; Mobile and Portable Antennas; What Kind of Antenna; Making the Antenna Work; Antenna Construction and Erection. Copyright 1982, 1st Edition, Hardbound \$12.00.

**ANTENNA ANTHOLOGY** The best QST hf antenna articles and theory presentations. Verticals: 2 and 4 band verticals for the novice, Cheapie GP, High Performance system for 20, 40 and 80, other loaded systems. Yagis: Short antennas, and The Log-Yag Array. Quads: Wire quads for 80 and 40, 2-Element Quad for the Novice, Miscellaneous Antennas: Loops, Delta-loops, Antennas for travel trailers and campers, plus matching devices and antenna test accessories. Copyright 1978, 148 pages. \$4.00 U.S., \$4.50 elsewhere.

Enclosed in U.S. funds drawn on a U.S. bank or an international money order is \$ \_\_\_\_\_ for the books marked below:

- ( ) ARRL Antenna Book \$8 U.S. \$8.50 elsewhere
- ( ) HF Antennas \$12.00
- ( ) Antenna Anthology \$4 U.S. \$4.50 elsewhere

NAME \_\_\_\_\_

ADDRESS \_\_\_\_\_

CITY, STATE OR PROVINCE, ZIP OR POSTAL CODE \_\_\_\_\_

Charge to my  Master Charge  Visa \_\_\_\_\_

Account number \_\_\_\_\_ expires \_\_\_\_\_

**A.R.R.L.**  
225 Main Street  
Newington, CT 06111

Bank number (MC) \_\_\_\_\_



*Ham Radio's guide to help you find your local*

## California

**C & A ELECTRONIC ENTERPRISES**  
22010 S. WILMINGTON AVE.  
SUITE 105  
CARSON, CA 90745  
213-834-5868  
Not The Biggest, But The Best —  
Since 1962.

**FONTANA ELECTRONICS**  
8628 SIERRA AVENUE  
FONTANA, CA 92335  
714-822-7710  
714-822-7725  
The Largest Electronics Dealer in San  
Bernardino County.

**JUN'S ELECTRONICS**  
3919 SEPULVEDA BLVD.  
CULVER CITY, CA 90230  
213-390-8003 Trades  
714-463-1886 San Diego  
800-882-1343  
The Home of the One Year Warranty  
— Parts at Cost — Full Service.  
Habla Espanol

**SHAVER RADIO, INC.**  
1378 S. BASCOM AVENUE  
SAN JOSE, CA 95128  
408-998-1103  
Azden, Icom, Kenwood, Tempo,  
Ten-Tec, Yaesu and many more.

## Connecticut

**HATRY ELECTRONICS**  
500 LEDYARD ST. (SOUTH)  
HARTFORD, CT 06114  
203-527-1881  
Call today. Friendly one-stop shop-  
ping at prices you can afford.

## Delaware

**DELAWARE AMATEUR SUPPLY**  
71 MEADOW ROAD  
NEW CASTLE, DE 19720  
302-328-7728  
800-441-7008  
Icom, Ten-Tec, DenTron, Yaesu,  
Azden, Santec, KDK, and more.  
One mile off I-95, no sales tax.

## Florida

**AMATEUR ELECTRONIC SUPPLY**  
1898 DREW STREET  
CLEARWATER, FL 33515  
813-461-HAMS  
Clearwater Branch  
West Coast's only full service  
Amateur Radio Store.

**AMATEUR ELECTRONIC SUPPLY**  
621 COMMONWEALTH AVE.  
ORLANDO, FL 32803  
305-894-3238  
Fla. Wats: 1 (800) 432-9424  
Outside Fla: 1 (800) 327-1917

**AMATEUR RADIO CENTER, INC.**  
2805 N.E. 2ND AVENUE  
MIAMI, FL 33137  
305-573-8383  
The place for great dependable  
names in Ham Radio.

**RAY'S AMATEUR RADIO**  
1590 US HIGHWAY 19 SO.  
CLEARWATER, FL 33516  
813-535-1416  
Your complete Amateur Radio and  
Computer Store.

## Illinois

**ERICKSON COMMUNICATIONS, INC.**  
5456 N. MILWAUKEE AVE.  
CHICAGO, IL 60630  
Chicago — 312-631-5181  
Outside Illinois — 800-621-5802  
Hours: 9:30-5:30 Mon, Tu, Wed & Fri;  
9:30-8:00 Thurs; 9:00-3:00 Sat.

## Indiana

**THE HAM SHACK**  
808 NORTH MAIN STREET  
EVANSVILLE, IN 47710  
812-422-0231  
Discount prices on Ten-Tec, Cubic,  
Hy-Gain, MFJ, Azden, Kantronics,  
Santec and others.

## Kansas

**ASSOCIATED RADIO**  
8012 CONSER, P. O. BOX 4327  
OVERLAND PARK, KS 66204  
913-381-5900  
America's No. 1 Real Amateur Radio  
Store. Trade — Sell — Buy.

## Maryland

**THE COMM CENTER, INC.**  
LAUREL PLAZA, RT. 198  
LAUREL, MD 20810  
800-638-4486  
Kenwood, Drake, Icom, Ten-Tec,  
Tempo, DenTron, Swan & Apple  
Computers.

## Massachusetts

**TEL-COM, INC.**  
675 GREAT ROAD, RTE. 119  
LITTLETON, MA 01460  
617-486-3040  
617-486-3400 (this is new)  
The Ham Store of New England  
You Can Rely On.

## Minnesota

**MIDWEST AMATEUR RADIO SUPPLY**  
3452 FREMONT AVE. NO.  
MINNEAPOLIS, MN 55412  
612-521-4662  
It's service after the sale that counts.

## Nevada

**AMATEUR ELECTRONIC SUPPLY**  
1072 N. RANCHO DRIVE  
LAS VEGAS, NV 89106  
702-647-3114  
Dale Porray "Squeak," AD7K  
Outside Nev: 1 (800) 634-6227

**JUN'S ELECTRONICS**  
460 E. PLUMB LANE — 107  
RENO, NV 89502  
702-827-5732  
Outside Nev: 1 (800) 648-3962  
Icom — Yaesu Dealer

## New Hampshire

**TUFTS ELECTRONICS**  
61 LOWELL ROAD  
HUDSON, NH 03051  
603-883-5005  
New England's friendliest ham store.

## New Jersey

**RADIOS UNLIMITED**  
P. O. BOX 347  
1760 EASTON AVENUE  
SOMERSET, NJ 08873  
201-469-4599  
800-526-0903  
New Jersey's only factory authorized  
Yaesu and Icom distributor. New and  
used equipment. Full service shop.

**ROUTE ELECTRONICS 46**  
225 ROUTE 46 WEST  
TOTOWA, NJ 07512  
201-256-8555

**ROUTE ELECTRONICS 17**  
777 ROUTE 17 SOUTH  
PARAMUS, NJ 07625  
201-444-8717  
Drake, Cubic, DenTron, Hy-Gain,  
Cushcraft, Hustler, Larsen, MFJ,  
Butternut, Fluke & Beckman  
Instruments, etc.

**Dealers:** *YOU SHOULD BE HERE TOO!*  
*Contact Ham Radio now for complete details.*

## Amateur Radio Dealer

### New York

**BARRY ELECTRONICS**  
512 BROADWAY  
NEW YORK, NY 10012  
212-925-7000  
New York City's Largest Full Service  
Ham and Commercial Radio Store.

**GRAND CENTRAL RADIO**  
124 EAST 44 STREET  
NEW YORK, NY 10017  
212-599-2630  
Drake, Kenwood, Yaesu,  
Ten-Tec, DenTron, Hy-Gain,  
Mosley in stock.

**HARRISON RADIO CORP.**  
20 SMITH STREET  
FARMINGDALE, NY 11735  
516-293-7990  
"Ham Headquarters USA" since  
1925. Call toll free 800-645-9187.

**RADIO WORLD**  
ONEIDA COUNTY AIRPORT  
TERMINAL BLDG.  
ORISKANY, NY 13424  
TOLL FREE 1 (800) 448-9338  
NY Res. 1 (315) 337-0203  
Authorized Dealer — ALL major  
Amateur Brands.  
We service *everything* we sell!  
Warren K2IXN or Bob WA2MSH.

### Ohio

**AMATEUR ELECTRONIC SUPPLY**  
28940 EUCLID AVE.  
WICKLIFFE, OH (CLEVELAND AREA)  
44092  
216-585-7388  
Ohio Wats: 1 (800) 362-0290  
Outside Ohio: 1 (800) 321-3594

**UNIVERSAL AMATEUR RADIO, INC.**  
1280 AIDA DRIVE  
REYNOLDSBURG (COLUMBUS), OH  
43068  
614-866-4267  
Featuring Kenwood and all other  
Ham gear. Authorized sales and ser-  
vice. Shortwave headquarters. Near  
I-270 and airport.

### Oklahoma

**DERRICK ELECTRONICS, INC.**  
714 W. KENOSHA — P.O. BOX A  
BROKEN ARROW, OK 74012  
Your *Discount* Ham equipment dealer  
in Broken Arrow, Oklahoma  
1-800-331-3688 or  
1-918-251-9923

### Pennsylvania

**HAMTRONICS,**  
DIV. OF TREVOSE ELECTRONICS  
4033 BROWNSVILLE ROAD  
TREVOSE, PA 19047  
215-357-1400  
Same Location for 30 Years.

**LaRUE ELECTRONICS**  
1112 GRANDVIEW STREET  
SCRANTON, PENNSYLVANIA 18509  
717-343-2124  
Icom, Bird, Cushcraft, Beckman,  
Fluke, Larsen, Hustler, Astron,  
Antenna Specialists, W2AU/W2VS,  
AEA, B&W, CDE, Sony, Vibroplex.

### Texas

**MADISON ELECTRONICS SUPPLY**  
1508 MCKINNEY  
HOUSTON, TX 77010  
713-658-0268  
Christmas?? Now?? See ad index  
page.

### Virginia

**ELECTRONIC EQUIPMENT BANK**  
516 MILL STREET, N.E.  
VIENNA, VA 22180  
703-938-3350  
Metropolitan D.C.'s One Stop  
Amateur Store. Largest Warehousing  
of Surplus Electronics.

### Wisconsin

**AMATEUR ELECTRONIC SUPPLY**  
4828 W. FOND DU LAC AVE.  
MILWAUKEE, WI 53216  
414-442-4200  
Wisc. Wats: 1 (800) 242-5195  
Outside Wisc: 1 (800) 558-0411

**SAY  
YOU SAW  
IT IN  
ham radio!**

# !NEW!

FROM

## KENWOOD



**TS430S**  
New Gen. Cov.  
Solid State Transceiver



**R2000**  
New Gen. Cov.  
Rcvr. W/memories



**TS930S**

**THE  
COMM  
CENTER** 20810  
INC.  
Laurel Plaza  
Route 198  
Laurel, Md.

MD.: 301-792-0600  
OPEN MON. THROUGH SAT.

**CALL TOLL FREE  
1-800-638-4486**

# quality says it all...

## ROHN

### Foldover Towers

ROHN "fold-over" Towers offer unbeatable value. These towers let you work completely on the ground for antenna and rotator installation and servicing eliminating the need of climbing the tower. Send \$2.00 for complete catalog.

**UNR-Rohn**  
 Division of UNR, Inc.  
 P.O. Box 2000  
 6718 West Plank Road  
 Peoria, Illinois 61656  
 Ph. 309-697-4400  
 USA

Wheaton Community Radio Amateurs

## HAMFEST

Sunday, February 6, 1983

Boors open 8 a.m.

**Arlington Park  
 Expo Center**  
 Arlington Park Race Track  
 Arlington Heights, Illinois  
 Northwest of Chicago

- FREE FLEA MARKET TABLES
- 100 COMMERCIAL BOOTHS
- ALL IN ONE BUILDING
- ACRES OF CLEAR PAVED PARKING
- HOURLY DOOR PRIZES
- RESERVED FLEA MARKET TABLES
- SPECIAL COMPUTER SECTION
- TECH PROGRAMS

TICKETS: \$3.00 at door  
 \$2.50 in advance

Send S.A.S.E. to:  
 Wheaton Community Radio Amateurs  
 P.O. Box Q5L  
 Wheaton, IL 60187



Talk in on 146.94 MHz. and 146.01/61 MHz.  
 For general information:  
 Call (312) 231-9524  
 For Commercial Booth information:  
 Call (312) 766-1884

## ORR BOOKS

### BEAM ANTENNA HANDBOOK

by Bill Orr, W6SAI

Recommended reading. Commonly asked questions like: What is the best element spacing? Can different yagi antennas be stacked without losing performance? Do monoband beams outperform tribanders? Lots of construction projects, diagrams, and photos. 198 pages. ©1977, 1st edition.

RP-BA Softbound \$5.95

### SIMPLE LOW-COST WIRE ANTENNAS

by Bill Orr, W6SAI

Learn how to build simple, economical wire antennas. Apartment dwellers take note! Fool your landlord and your neighbors with some of the "invisible" antennas found here. Well diagramed. 192 pages. ©1972.

RP-WA Softbound \$6.95

### THE RADIO AMATEUR ANTENNA HANDBOOK

by William I. Orr, W6SAI and Stuart Cowan, W2LX

Contains lots of well illustrated construction projects for vertical, long wire, and HF/VHF beam antennas. There is an honest judgment of antenna gain figures, information on the best and worst antenna locations and heights, a long look at the quad vs. the yagi antenna, information on baluns and how to use them, and new information on the popular Sloper and Delta Loop antennas. The text is based on proven data plus practical, on-the-air experience. **The Radio Amateur Antenna Handbook** will make a valuable and often consulted reference. 190 pages. ©1978.

RP-AH Softbound \$6.95

### ALL ABOUT CUBICAL QUAD ANTENNAS

by Bill Orr, W6SAI

The cubical quad antenna is considered by many to be the best DX antenna because of its simple, lightweight design and high performance. You'll find quad designs for everything from the single element to the multi-element monster quad, plus a new, higher gain expanded quad (X-Q) design. There's a wealth of supplementary data on construction, feeding, tuning, and mounting quad antennas. 112 pages. ©1977.

RP-CQ Softbound \$5.95

Please add \$1.00 to cover shipping and handling

## HAM RADIO'S BOOKSTORE

GREENVILLE, NH 03048

## NEW TS830S for \$150?

Yes indeed! Just add a Matched Pair of top-quality 2.1 kHz BW (bandwidth) Fox Tango Filters. Here are a few quotes from users:

"... Makes a new rig out of my old TS830S! ..."  
 "... VBT now works the way I dreamed it should ..."  
 "... Spectacular improvement in SSB selectivity ..."  
 "... Completely eliminates my need for a CW filter ..."  
 "... Simple installation — excellent instructions ..."

The Fox Tango filters are notably superior to both original 2.7 kHz BW units but especially the modest ceramic 2nd IF; our substitutes are 8-pole discrete-crystal construction. The comparative FT vs Kenwood results? VBT OFF — RX BW: 2.0 vs 2.4; Shape Factor: 1.19 vs 1.34; 80 dB BW: 2.48 vs 3.41; Ultimate Rejection: 110 dB vs 80. VBT SET FOR CW at 300 Hz BW — SF 2.9 vs 3.33; Insertion Loss: 1 dB vs 10 dB.

**AND NOW A NEW TS930S!** Tests prove that the same filters improve the '930 even more than the '830. Don't buy CW filters — not even ours. You probably won't need them!

### INTRODUCTORY PRICE: (Complete Kit) ... \$150

Includes Matched Pair of Fox Tango Filters, all needed cables, parts, detailed instructions

Specify kit desired: FTK-830 or FTK-930  
 Shipping \$3 (Air \$5). FL Sales Tax 5%



### ONE YEAR WARRANTY GO FOX-TANGO — TO BE SURE!

Order by Mail or Telephone.  
 AUTHORIZED EUROPEAN AGENTS  
 Scandinavia: MICROTEC (Norway)  
 Other: INGOIMPEX (W. Germany)

### FOX TANGO CORPORATION

Box 15944H, W. Palm Beach, FL 33406  
 Phone: (305) 683-9587



## EM-3

**2300 MHz MICROWAVE DOWNCONVERTER KIT.** Includes high quality PC board, NE02137 & NE02136 transistors, thermal drift stabilizer, silver solder, .141 hardline, matched diodes, F-connectors, molded coils, instructions.

**EM-4** The EM-3 with NE64535 high performance RF transistor; Adds 3db gain to EM-3 and reduces noise figure. 25.95

## DO IT RIGHT THE FIRST TIME WITH SUPERIOR QUALITY — WITHOUT HIDDEN COSTS

THOSE OTHER  
 "DEALS" DON'T  
 HAVE IT ALL —  
**WE DO!**

- Detailed Instructions
- Post-Paid Delivery
- Thermal Drift Stabilizer
- F-Connectors
- Hardline Antenna Probe
- High Gain RF Stage
- Matched Diodes
- Molded Coils
- Silver Solder
- Toll-Free Number

Sale!

Sale!

Send SASE for Catalogue

Sale!



DA-3 46.95  
EM-3 & RFA-1



TU-8 Power  
Supply 32.95



ANT-4 Antenna 24.95  
with Adjustable Bracket



RFA-1 29.95  
Preamp

# SMP

Superior Microwave Products, Inc.  
 P.O. Box 1241  
 Vienna, VA 22180

Orders Only: 1-800-368-3028  
 Info., VA & D.C.: 1-703-255-2918

Discounts  
 All Orders Postpaid & Shipped in 48 Hours

We Don't Compromise On Quality



HOW CAN I INTERCEPT  
 SMUGGLERS? SECRET  
 SATELLITES? RESCUE  
 MISSIONS? SIGNALS  
 FROM SPACE?

WHAT IS THE TRUTH  
 ABOUT ANTENNAS?  
 TUNERS? PREAMPLIFIERS?

HOW CAN I CHOOSE THE BEST  
 RECEIVER? ANTENNA?

WHAT ARE THE LAWS REGARD-  
 ING LISTENING IN?

UNCOVER LISTENING  
 EXCITEMENT YOU  
 NEVER THOUGHT  
 POSSIBLE!

For your **FREE COPY** of  
 MONITORING TIMES--

**CALL NOW!** Toll-free  
 1-800/438-8155  
 (cont. US except NC).

Others dial 1-704/837-2216

or write to

Grove Enterprises, Dept. H, 140 Dog Branch Road  
 Brasstown, NC 28902

Introducing our Latest Model — NOVAX II

SIMPLEX / DUPLEX  
 AUTOPATCH

NOVAX I



NOVAX II

**NOW TWO MODELS TO  
 SERVE YOU BETTER**  
 YOUR OWN PRIVATE AUTOPATCH

**NOVAX**  
 MOBILE CONNECTION

NOVAX interfaces your standard 2 meter; 220; 450; etc. Base station and telephone, using a high speed scan switching technique so that you can direct dial from your automobile or with your HT from the backyard or poolside — Automatically ... Easy installation transceivers, featuring solid state switching, offer best results ... Available interfaced with an ICOM 22U.

FEATURES	NOVAX I	NOVAX II
• 3 min. Call duration timer	YES	YES
• Up to 45 sec. activity timer	YES	YES
• Single digit Access Control	YES	NO
• DTMF (Touch Tone)* phone connection	YES	YES
• 4 digit Access Control	NO	YES
• Toll Restrict	NO	YES
• LED Digital Display	NO	YES
• Vinyl covered alum. case size	5" x 6" x 2"	10" x 8" x 1 1/2"
• Directly Interfaces with Repeater	NO	YES
• Rotary Dial System (incl. Last digit dial)	NO	YES—"Option"—\$49.95
• Ring Back (reverse autopatch) "Option"	YES—\$39.95; Kit \$29.95	YES—Wired—\$39.95
• Price	Kit: \$169.95/wired \$219.95	Wired only \$279.95
N.Y.S. Res. add appro. Sales Tax		SHIPPING ADD \$3.50 in U.S.A.

To order, send  
 check, money  
 order to:  
 MASTER CHARGE  
 AND VISA ACCEPTED

LIBRENT  
 DEVELOPMENT  
 CORPORATION  
 (formerly R.W.D. Inc.)

Box 162 - Tudman Rd.  
 Westmoreland, N.Y. 13490  
 or Phone 315-829-2785

\* Trademark ITT

# Advertisers check-off

... for literature, in a hurry — we'll rush your name to the companies whose names you "check-off"

Place your check mark in the space between name and number. Ex: Ham Radio  234

Advanced Receiver Research <input type="checkbox"/> 919	Jameco <input type="checkbox"/> 333
Alaska Microwave <input type="checkbox"/> 826	Jensen <input type="checkbox"/> 293
All Elec. <input type="checkbox"/> 926	Kenwood <input type="checkbox"/>
Alpha Delta <input type="checkbox"/> 949	Lockwood <input type="checkbox"/> 059
ARRL <input type="checkbox"/> 780	Long's <input type="checkbox"/> 468
Amidon <input type="checkbox"/> 005	Lunar <input type="checkbox"/> 577
Amp Supply <input type="checkbox"/> 991	MFJ <input type="checkbox"/> 082
Applied Inv. <input type="checkbox"/> 862	Madison <input type="checkbox"/> 431
Atlantic Surplus <input type="checkbox"/>	Melco <input type="checkbox"/> 938
ATV Magazine <input type="checkbox"/> 001	M-Squared Eng. <input type="checkbox"/> 029
AutoConnect <input type="checkbox"/> 037	Nampa Satellite <input type="checkbox"/> 072
Barker & Williamson <input type="checkbox"/> 015	Nemal <input type="checkbox"/> 968
Barry <input type="checkbox"/>	Nuts & Volts <input type="checkbox"/> 073
Bilal <input type="checkbox"/> 817	Oak Hill Academy A. R. S. <input type="checkbox"/>
Buckmaster <input type="checkbox"/> 052	Orlando Hamcation <input type="checkbox"/>
Budwig <input type="checkbox"/> 233	P. B. Radio <input type="checkbox"/> 921
Butternut <input type="checkbox"/>	P. C. <input type="checkbox"/>
Caddell Coil <input type="checkbox"/> 244	Palomar Eng. <input type="checkbox"/>
Ceco <input type="checkbox"/> 054	Peterson Elec. <input type="checkbox"/> 047
Comm. Design <input type="checkbox"/> 071	Power General <input type="checkbox"/> 048
Comm. Spec. <input type="checkbox"/> 330	Pro-Search <input type="checkbox"/> 983
C. D. C. <input type="checkbox"/> 988	RF Products <input type="checkbox"/> 064
Dayton <input type="checkbox"/>	Callbook <input type="checkbox"/> 100
Delcraft <input type="checkbox"/> 061	Radiokit <input type="checkbox"/> 801
Dentron Radio <input type="checkbox"/> 259	Radio Warehouse <input type="checkbox"/>
Doppler <input type="checkbox"/> 003	Sherwood <input type="checkbox"/>
Elec. Specialists <input type="checkbox"/> 039	Simple Simon <input type="checkbox"/> 998
Epsilon <input type="checkbox"/> 040	Sinclair <input type="checkbox"/>
Fair Radio <input type="checkbox"/> 048	Spectronics <input type="checkbox"/>
Ferritronics <input type="checkbox"/> 041	Spectrum Int. <input type="checkbox"/> 108
Fox-Tango <input type="checkbox"/> 657	S. M. P. <input type="checkbox"/> 074
GC Elec. <input type="checkbox"/> 076	Tektronix <input type="checkbox"/>
Galaxy <input type="checkbox"/> 026	Telex <input type="checkbox"/>
Goldsmith Scientific <input type="checkbox"/> 042	Tennessee Elec. <input type="checkbox"/> 031
Grand Systems <input type="checkbox"/> 027	Ten-Tec <input type="checkbox"/>
Grove <input type="checkbox"/> 848	TET <input type="checkbox"/> 009
Hal Comm. <input type="checkbox"/> 057	Texas Towers <input type="checkbox"/> 681
Hallward <input type="checkbox"/> 043	The Comm Center <input type="checkbox"/> 634
H. R. B. <input type="checkbox"/> 150	Tri-Ex <input type="checkbox"/> 075
Ham Shack <input type="checkbox"/> 879	Tropical Hamboree <input type="checkbox"/>
Hamtronics, N.Y. <input type="checkbox"/> 246	Ungar <input type="checkbox"/> 062
Hoosier <input type="checkbox"/> 977	Universal Comm. <input type="checkbox"/> 885
Icom <input type="checkbox"/>	UNR-Rohn <input type="checkbox"/> 410
Ind. Crystal <input type="checkbox"/> 005	Vanguard Labs <input type="checkbox"/> 716
Int. Solar <input type="checkbox"/> 028	Western <input type="checkbox"/> 909
JL Industries <input type="checkbox"/> 077	Wheaton Hamfest <input type="checkbox"/>
JWL <input type="checkbox"/> 058	Yaesu <input type="checkbox"/> 127

\*Please contact this advertiser directly.  
Limit 15 inquiries per request.

January, 1983

Please use before March 31, 1983

Tea off and mail to  
HAM RADIO MAGAZINE — "check off"  
Greenville, N. H. 03048-0498

NAME.....  
CALL.....  
STREET.....  
CITY.....  
STATE..... ZIP.....

## HAPPY NEW EARS!

### KENWOOD TS-930S

CW/AM/SSB/FSK  
Transmit-all amateur bands 10-160,  
incl. WARC  
Receive 150kHz-30mHz general  
coverage  
Automatic antenna tuner-optional  
8 memory channels  
"Woodpecker" filter  
IF slope/CW VBT/IF NOTCH  
Speech processor  
**One yr. ltd. warranty parts & labor**  
List \$1799 w/tuner - Call!

### DRAKE TR-5

10-160 coverage incl. WARC/MARS\*  
Full break-in CW  
No tune-up — solid state  
150 watts pep input  
List \$799 Madison \$699  
\*w/optional crystal

### ICOM IC-740

Versatility plus! ICOM's newest addition to HF offers features most asked for by ham operators. 160-10 meters, variable noise blanker and AGC with off position. IF shift and passband tuning, automatic SSB mode selection, notch filter, switchable CW filter, 8 memories, SWR meter, XIT, speech compressor, 100 watts and 12 volt operation. Options are FM, automatic keyer, internal AC power supply and 5 IF filters. *ICOM system compatible.*

List \$1099 Madison \$969

### YAESU FT-102

Unique cascaded filter system, all new receiver front end, IF notch and audio peak filter, variable IF Bandwidth with IF Shift, wide/narrow filter selection, variable pulse width noise blanker, low distortion audio/IF stage design, heavy duty three-tube final amplifier, dual metering system, microphone amplifier tone control, RF speech processor, VOX with front panel controls, IF monitor circuit, WARC bands factory installed.

List \$1149 Madison \$999

### BUTTERNUT HF6V VERTICAL

\$125.00

w/30 meter coil

**MADISON**  
**Electronics Supply**  
1508 McKinney  
Houston, Texas 77010  
713-658-0268

## Advertisers Index

Advanced Receiver Research	80
Alaska Microwave Labs	47
All Electronics Corp.	47
Alpha Delta	63
American Radio Relay League	87
Amidon Associates	24
Amp Supply	50
Applied Invention	77
Atlantic Surplus Sales	81
ATV Magazine	50
AutoConnect	69
Barker & Williamson, Inc.	65
Barry Electronics	61
Bilal Company	85
Buckmaster Publishing	77
Budwig Mfg. Company	47
Butternut Electronics	79
Caddell Coil Corp.	72
Ceco	72
Communications Design, Inc.	63
Communications Specialists	76
Current Development Corp.	91
Dayton Hamvention	56, 78
Delcraft	54
Dentron Radio Co., Inc.	95
Doppler Systems	73
Electronic Specialists, Inc.	60
Epsilon Records	54
Fair Radio Sales	72
Ferritronics Limited	41
Fox-Tango Corp.	91
Galaxy Electronics	54
Goldsmith Scientific Corporation	85
Grand Systems	73
Grove Enterprises	91
Hal Communications Corp.	24, 73
Hallward Products	84
Ham Radio's Bookstore	24, 56, 65, 90
The Ham Shack	83
Hamtronics, N.Y.	77
Hoosier Electronics	56
Icom America, Inc.	Cover II
Independent Crystal Supply Company	63
International Solar	84
JWL Electronics	65
Jameco Electronics	73
Jensen Tools, Inc.	81
Trio-Kenwood Communications	2, Cover IV
H. N. Lockwood, Inc.	77
Long's Electronics	48, 49
Lunar Electronics	85
MFJ Enterprises	9
Madison Electronics Supply	92
Melco	73
M-Squared Engineering, Inc.	39
Nampa Satellite Receiver Systems	11
Nemal Electronics	72
Nuts & Volts Magazine	47
Oak Hill Academy Amateur Radio Session	50
Orlando Hamcation	78
P. B. Radio	84
P. C. Electronics	41
Palomar Engineers	50
Peterson Electronics	63
Power General	63
Pro-Search	55
RF Products	72
Radio Amateur Callbook	50
Radiokit	81
Radio Warehouse	72
Sherwood Engineering	84
Simple Simon Electronic Kits, Inc.	71
Sinclair Research Ltd.	7
Spectronics	86
Spectrum International, Inc.	35
Superior Microwave Products, Inc.	91
Tektronix	1
Telex Communications	22, 23
Tennessee Electronics	81
Ten-Tec	21
TET Antenna Systems	41
Texas Towers	47
The Comm Center	89
Tri-Ex Tower Corp.	60
Tropical Hamboree	78
Ungar, Division of Eldon Industries	96
Universal Communications	27
UNR-Rohn	80, 90
Vanguard Labs	81
Western Electronics	81
Wheaton Hamfest	90
Yaesu Electronics Corp.	Cover III

# Advertisers check-off

... for literature, in a hurry — we'll rush your name to the companies whose names you "check-off".

Place your check mark in the space between name and number. Ex: Ham Radio  234

Advanced Receiver		Ceco	054	Hallward	043	Nampa Satellite	072	Spectrum Int.	108
Research	919	Comm. Design	071	H. R. B.	150	Nerral	968	S. M. P.	074
Alaska Microwave		Comm. Spec.	330	Ham Shack	879	Nuts & Volts	073	Tektronix	*
All Elec.	926	C. O. C.	988	Hamtronics N. Y.	977	Oak Hill Academy A. R. S.		Telex	*
Alpha Delta	949	Dayton	*	Hobart	977	Oslando Hamclub	*	Tennessee Elec	
ARRL	780	Delcraft	061	Icom		P. B. Radio	921	Ten Tec	*
Arndon	035	Dentron Radio	259	Int. Crystal	065	P. C.		TEI	
Amp Supply	991	Doppler	003	Int. Solar	028	Patent Eng.	*	Texas Towers	681
Applied Inv.	862	Elec. Specialists	039	JL Industries	077	Peterson Elec.	047	The Comm. Center	634
Atlantic Surplus	*	Epsilon	040	JWL	058	Power General	048	To Ex	075
ATV Magazine	001	Fair Radio	048	Jameco	333	Pro Search	983	Tropical Hamboone	*
AutoConnect	037	Ferritronics	041	Jensen	293	RF Products	064	Unigat	062
Barker B.		Fox Tangle	657	Kenwood	*	Callbook	100	Univrsal Comm.	
Williamson	015	GC Elec.	076	Lockwood	059	RadioKit	801	UNR Rom	410
Barry	*	Galaxy	025	Long's	488	Radio Warehouse	*	Vanguard Labs.	716
Blal	817	Goltsmith-Scientific	042	Lunar	577	Shenwood	*	Western	909
Buckmaster	052	Grand Systems	027	M.F.J.	082	Simple Simon	988	Wheaton Hamfest	*
Burwig	233	Grove	048	Madison	431	Sincdar	*	Yates	127
Butterfield	*	Hal Comm	057	Metco	938	Spectronics	*		
Catball Coll	244			M-Squared Eng.	029				

\* Please contact this advertiser directly.

Limit 15 inquiries per request.

NAME \_\_\_\_\_ CALL \_\_\_\_\_  
 ADDRESS \_\_\_\_\_  
 CITY \_\_\_\_\_ STATE \_\_\_\_\_ ZIP \_\_\_\_\_  
 Please use before February 28, 1983 **January, 1983**

AFFIX POSTAGE  
OR  
POST OFFICE  
WILL NOT  
DELIVER

---

---

---

**ham**  
**radio**  
*magazine*

READER SERVICE CENTER  
P.O. BOX 358  
ARLINGTON, MA 02174

ATTN: Reader Service Dept.



# MERRY DX-MAS TO ALL

FROM YOUR FRIENDS AT DENTRON...  
ENJOY!

Even Santa couldn't wait to get on the air with the latest fun and excitement from Dentron Radio...our new MLX MINI and the STATION ONE. Try the MLX Mini yourself, it's a monoband, HF transceiver that has all the performance of a big rig, yet it's small enough to fit in your stocking. Even the price is small, suggested retail **\$289.50**. Get in on the fun with our new Station One, it's the perfect gift for Novices and QRPers alike. This 25W, 3 band, CW transceiver can be worked at home base or plugged into a 12V battery for mobile use. Suggested retail is **\$269.95**. Gear up with Dentron for a Merry Christmas and a fun New Year.



**DENTRON**  
1605 Commerce Drive  
Stow, Ohio 44224  
(216) 688-4973 Telex 241-633

Dealer Inquiries Invited.  
Visit your favorite dealer or write  
today for our new 1983 catalog.

# Modular Components... The Soldering Choice is Yours

## With Ungar's 3000 Series Heaters, Handles and Tips

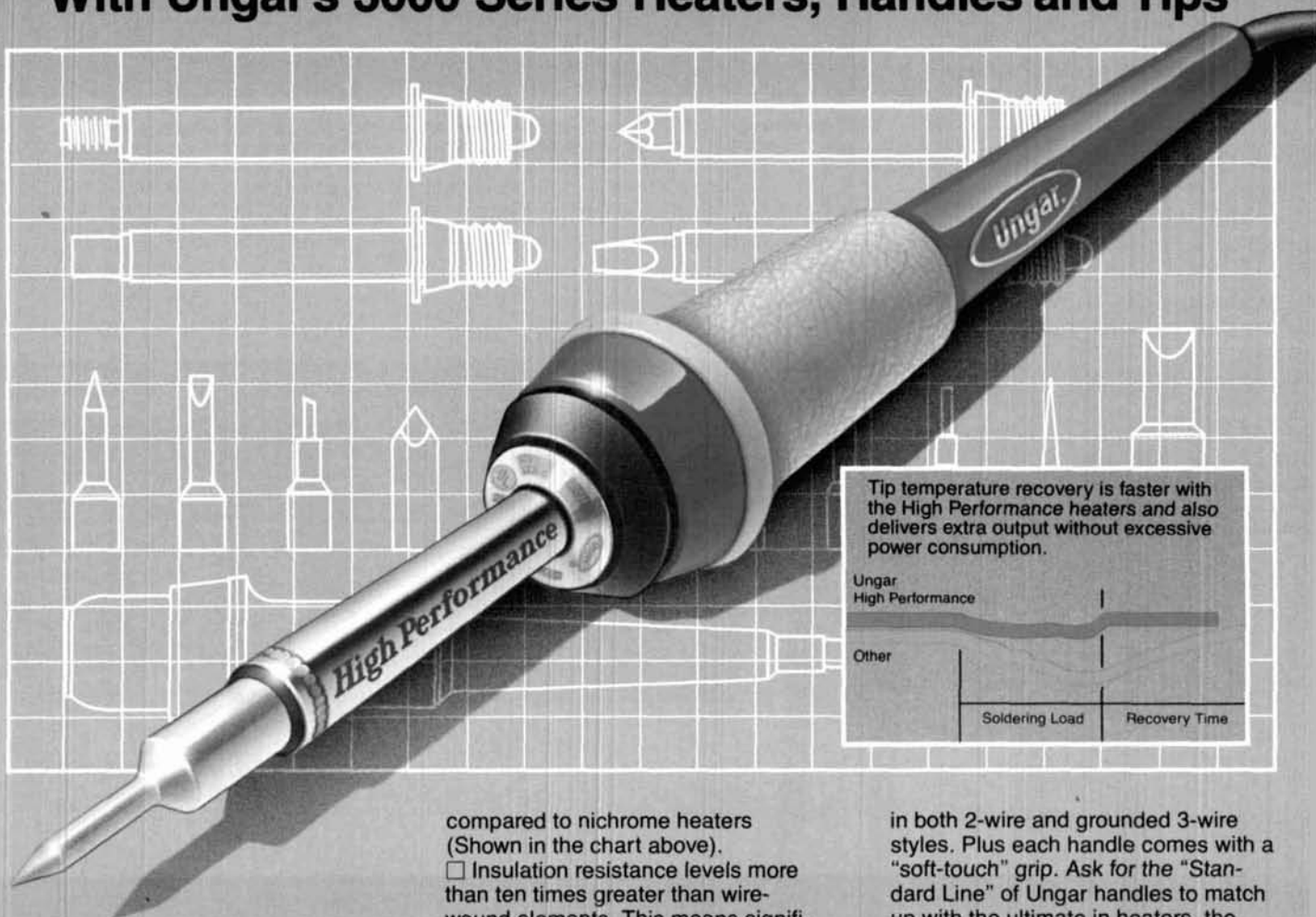

Tip temperature recovery is faster with the High Performance heaters and also delivers extra output without excessive power consumption.

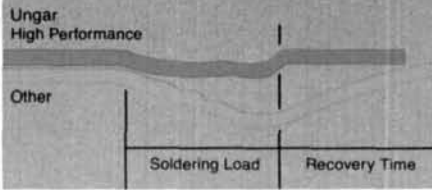

When it comes to making a choice, Ungar gives you lots to choose from. We have one of the broadest lines of soldering components available to precisely meet your needs.

Take our lineup of heaters, handles and tips, for example. We've got you covered with a variety of heat ranges and tips so you can custom-design the soldering iron to fulfill your requirements.

### 15 NEW THERMO-DURIC™ HIGH PERFORMANCE HEATERS

Our 3000 Series heaters are the state-of-the-art in soldering today. Their improved performance is thanks to modern "thick film" technology, which has allowed the design of our exclusive, revolutionary THERMO-DURIC™ heater element.

The benefits include:

- Faster heat-up—typically 1.5 minutes vs. 2.5 minutes.
- Quicker temperature recovery

compared to nichrome heaters (Shown in the chart above).

- Insulation resistance levels more than ten times greater than wire-wound elements. This means significant reduction in leakage currents that can damage sensitive micro-electronics.
  - Lower power consumption—our 50 watt heater outperforms a conventional 80 watt iron.
  - Less energy consumed at no-load idle temperatures—typically 15% less!
  - Better results with thread-in and thread-on tips.
- And that's not all!

You can choose from a wide selection of body styles. Ranging from integral tip models to the thread-in and thread-on styles. Plus each style is available in wattage ratings to cover soldering temperatures from approximately 700°F to 1,000°F.

### HANDLES—WE OFFER YOU THREE CHOICES

To complement our 3000 Series heaters, we have three handles. They are perfectly balanced for added comfort and reduced fatigue. They're available

in both 2-wire and grounded 3-wire styles. Plus each handle comes with a "soft-touch" grip. Ask for the "Standard Line" of Ungar handles to match up with the ultimate in heaters, the 3000 series!

### SELECT FROM 15 TIPS

No matter your requirements, we've got the tip for you! Available in both thread-in and thread-on styles to mate with our 3000 Series heaters.

### AND IT'S ALL MODULAR!

That's the beauty of the Ungar system. Every piece is modular, so if one unit wears, instead of buying a totally new soldering iron—simply replace that one component. Fast, Easy, and Economical. You have unparalleled flexibility to combine handle, heater and tips to create any one of 234 custom irons.

To find out more about this amazing lineup from Ungar, call the Ungar Hotline, toll-free 1-800-421-1538, in California, call collect, 1-213-774-5950.



Division of Eldon Industries,  
Compton, California 90220  
In Canada, Markham,  
Ontario, Canada L3R 1H5



# MEET THE NEW YAESU FT-102



The FT-102 is factory equipped for operation on all present and proposed Amateur HF bands. An extra AUX band position is available for special applications. Equipped for SSB, CW, and AM (RX), the FT-102 may be activated on FM and AM (TX) via the optional AM/FM-102 Module.

The all-new receiver front end utilizes a low-distortion RF preamplifier that may be bypassed via a front panel switch when not needed. Maximum receiver performance is yours with this impressive lineup of standard features: IF Notch Filter, Audio Peak Filter, Variable IF Bandwidth Control, IF Shift, Variable Pulse Width Noise Blanker, Independent SSB and CW Audio Channels with Optimized Audio Bandwidth, and Front Panel Audio Tone Control. Wide/Narrow filter selection is independent of the Mode switch.

The celebrated transmitter section is powered by three 6146B final tubes, for more consistent power output and very low distortion. An RF Speech Processor, Mic Amp Audio Tone Control, VOX, and an IF Monitor round out the transmitter lineup.

Futuristic panel design and careful human engineering are the hallmarks of the FT-102. Convenient pop-out controls below the meters may be retracted when not in use, thus avoiding inadvertent mistuning. Abundant relay contacts, rear panel phono jacks for PTT, microphone/patch input, and other essential interface connections make the FT-102 extremely simple to incorporate into your station.

## SPECIFICATIONS

### TRANSMITTER

Power Input: (1.8-25 MHz) (28-29.9 MHz)	
SSB, CW	240W DC 160W DC
AM	80W DC 80W DC
FM	160W DC

### RECEIVER

Image Rejection:  
Better than 70dB from 1.8-21.5 MHz  
Better than 50dB from 24.5-29.9 MHz

IF rejection:  
Better than 70 dB

Selectivity (-6 dB/ -60 dB):  
SSB, CW, AM; 2.7/4.8 kHz (with no optional filters)  
Width adjusts continuously from 2.7 kHz to 500 Hz (-6 dB)

Spurious Radiation: Better than -40 dB



### SP-102

The SP-102 External Speaker/Audio Filter features a large, high-fidelity speaker with selectable low- and high-cut audio filters. The front panel A-B switch allows selection of two receiver inputs for maximum versatility. Also available is the SP-102P Speaker/Patch.

See your Authorized Yaesu Dealer today for a hands-on demonstration of the rig that everybody's talking about. It's the FT-102, The Transceiver of Champions!

Price And Specifications Subject To Change Without Notice or Obligation

1082

### FV-102DM

The FV-102DM Synthesized External VFO tunes in 10 Hz steps. Keyboard entry of frequencies, UP/DOWN scanning, and 12 memories make the FV-102DM a "must" for serious DX or contest work.

### FC-102

The FC-102 Antenna Coupler is capable of handling 1.2KW of transmitter power, with an in-line wattmeter, separate SWR meter, and A-B input/output selection expanding your station's capability. The optional FAS-1-4R allows remote selection of up to four antennas via one coaxial cable connected to the FC-102.



**YAESU ELECTRONICS CORP.** 6851 Walthall Way, Paramount, CA 90723 • (213) 633-4007  
Eastern Service Ctr., 9812 Princeton-Glendale Rd., Cincinnati, OH 45246 • (513) 874-3100

# NEW

# "DX-traordinary."



**Superior dynamic range, auto. antenna tuner, QSK, dual NB, 2 VFO's, general coverage receiver.**

## TS-930S

The TS-930S is a superlative, high performance, all-solid state, HF transceiver keyed to the exacting requirements of the DX and contest operator. It covers all Amateur bands from 160 through 10 meters, and incorporates a 150 kHz to 30 MHz general coverage receiver having an excellent dynamic range.

Among its other important features are, SSB slope tuning, CW VBT, IF notch filter, CW pitch control, dual digital VFO's, CW full break-in, automatic antenna tuner, and a higher voltage operated solid state final amplifier. It is available with or without the AT-930 automatic antenna tuner built-in.

### TS-930S FEATURES:

- **160-10 Meters, with 150 kHz-30 MHz general coverage receiver.** Covers all Amateur frequencies from 160-10 meters, including new WARC bands, on SSB, CW, FSK, and AM. Features 150 kHz-30 MHz general coverage receiver. Separate Amateur band access keys allow speedy band selection. UP/DOWN bandwidth in 1-MHz steps. A new, innovative, quadruple "UP" conversion, digital PLL synthesized circuit provides superior frequency accuracy and stability, plus greatly enhanced selectivity.
- **Excellent receiver dynamic range.** Receiver two-tone dynamic range, 100 dB typical (20 meters, 50-kHz spacing, 500 Hz CW bandwidth, at sensitivity of 0.25  $\mu$ v, S/N 10 dB), provides the ultimate in rejection of IM distortion.
- **All solid state, 28 volt operated final amplifier.** The final amplifier operates on 28 VDC for lowest IM distortion. Power input rated at 250 W on SSB, CW, and FSK, and at 80 W on AM. Final amplifier protection circuits with cooling fan, SWR/Power meter built-in.
- **CW full break-in.** CW full break-in circuit uses CMOS logic IC plus reed relay for smooth, quiet operation. Switchable to semi-break-in.

- **Automatic antenna tuner, built-in.** Covers Amateur bands 80-10 meters, including the new WARC bands. Tuning range automatically pre-selected with band selection to minimize tuning time. "AUTO-THRU" switch on front panel.
- **Dual digital VFO's.** 10-Hz step dual digital VFO's include band information. Each VFO tunes continuously from band to band. A large, heavy, flywheel type knob is used for improved tuning ease. T.F. Set switch allows fast transmit frequency setting for split-frequency operations. A=B switch for equalizing one VFO frequency to the other. VFO "Lock" switch provided. RIT control for  $\pm 9.9$  kHz.
- **Eight memory channels.** Stores both frequency and band information. VFO-MEMO switch allows use of each memory as an independent VFO. (the original memory frequency can be recalled at will), or as a fixed frequency. Internal Battery memory back-up, estimated 1 year life. (Batteries not Kenwood supplied).
- **Dual mode noise blanker ("pulse" or "woodpecker").** NB-1, with threshold control, for pulse-type noise. NB-2 for longer duration "woodpecker" type noise.
- **SSB IF slope tuning.** Allows independent adjustment of the low and/or high frequency slope of the IF passband, for best interference rejection. HIGH/LOW cut control rotation not affected by selecting USB or LSB modes.
- **CW VBT and pitch controls.** CW Variable Bandwidth Tuning control tunes out interfering signals. CW pitch controls shifts IF passband and simultaneously changes the pitch of the beat frequency. A "Narrow/Wide" filter selector switch is provided.
- **IF notch filter.** 100 kHz IF notch circuit gives deep, sharp, notch, better than -40 dB.
- **Audio filter built-in.** Tuneable, peak-type audio filter for CW.
- **AC power supply built-in.** 120, 220, or 240 VAC, switch selected (operates on AC only).

- **Fluorescent tube digital display.** Six digit readout to 100 Hz (10 Hz modifiable), plus digitalized sub-scale with 20-kHz steps. Separate two digit indication of RIT frequency shift. In CW mode, display indicates the actual carrier frequency of received as well as transmitted signals.
- **RF speech processor.** RF clipper type processor provides higher average "talk-power," improved intelligibility.
- **One year limited warranty on parts and labor.**
- **Other features:**
  - SSB monitor circuit, 3 step RF attenuator, VOX, and 100-kHz marker.
- **Optional accessories:**
  - AT-930 automatic antenna tuner.
  - SP-930 external speaker with selectable audio filters.
  - YG-455C-1 (500 Hz) or YG-455CN-1 (250 Hz) plug-in CW filters for 455-kHz IF.
  - YK-88C-1 (500 Hz) CW plug-in filter for 8.83-MHz IF.
  - YK-88A-1 (6 kHz) AM plug-in filter for 8.83-MHz IF.
  - SO-1 commercial stability TCXO (temperature compensated crystal oscillator). Requires modifications.
  - MC-60A deluxe desk microphone with UP/DOWN switch, pre-amplifier, 8-pin plug.
  - TL-922A linear amplifier (not for CW QSK).
  - SM-220 station monitor (not for pan-adaptor).
  - HS-6, HS-5, HS-4, headphones.

More Information on the TS-930S is available from all authorized dealers of Trio-Kenwood Communications, 1111 West Walnut Street, Compton, California 90220.

# KENWOOD

...pacesetter in amateur radio



Specifications and prices are subject to change without notice or obligation.