

WIRELESS

JANUARY 2023

THE UK'S NUMBER ONE AMATEUR RADIO MAGAZINE SINCE 1967

NOW INCORPORATING
RadioUser



NEW GEAR

Icom launch the IC-M510BB plus loads more products



WELL ROUNDED

Xiegu's curvy G-106 QRP portable transceiver is a 'friendly' easy to use radio at a good price

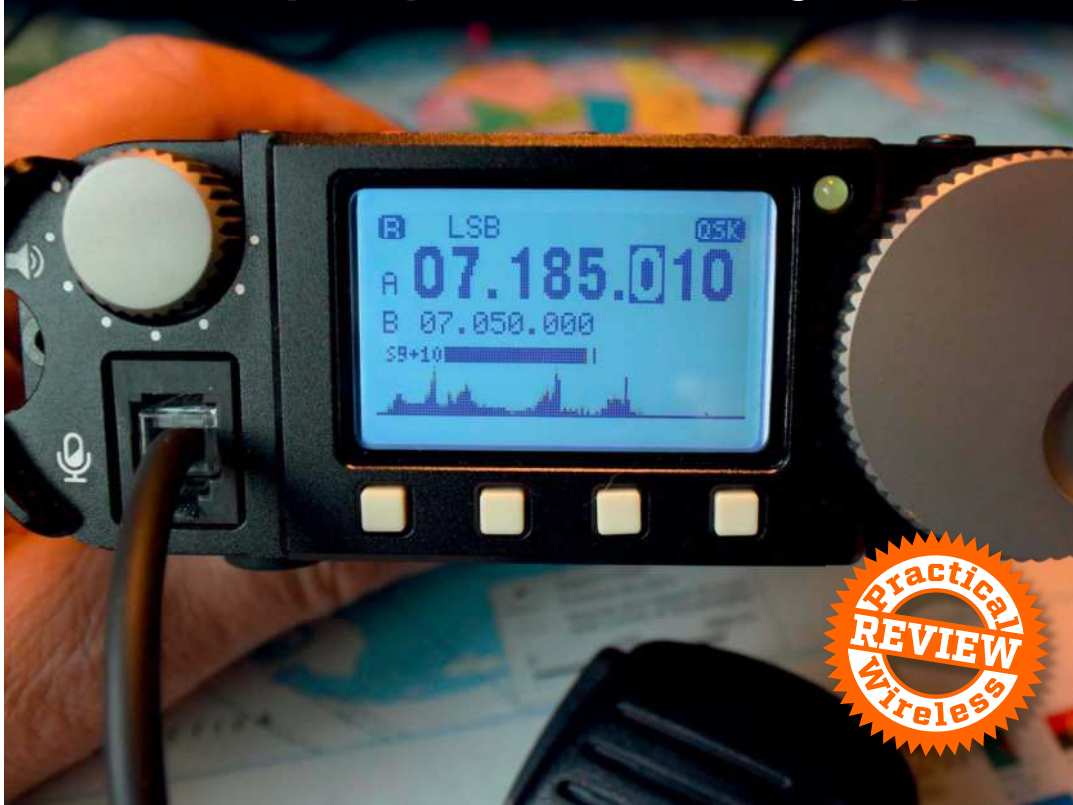

Rock'n'Roll Radio

Meet MOIEG - drummer with Britpop legends Blur



Turn Down the Noise

How attenuators reduce the amplitude of signals

ANTENNAS 14 pages packed with useful tips

Towbar mounts, VHF home-build, full-wave wire loop and loads more



HISTORY Morse speed contests over the years

A look at when transmitting fast was a major professional sport



ZOMHz RESULTS

All the winners from our 2022 competition

YOUR SAY

Letters from fellow readers



£5.99

Display until 12th January 2023

Enjoy "noise free" audio with a..
 ..bhi DSP noise cancelling product!

bhi

ParaPro EQ20 audio range with parametric equalisation



- Greatly improved audio for those with hearing loss
- 20W audio and parametric equalisation on all units
- Separate DSP noise cancelling and *Bluetooth versions
- Two separate mono inputs or one stereo input
- Use with passive speakers or headphones
- Basic EQ units EQ20, EQ20B* (use with your Dual In-Line, Compact In-Line or In-Line Module)
- DSP noise cancelling versions EQ20-DSP, EQ20B*-DSP

*Denotes Bluetooth on input
 EQ20B-DSP QST Dec 2019 review "easy-to-use device that improves the audio clarity of amateur signals"

Dual In-Line



- Fully featured flexible single or dual channel DSP noise cancelling unit
- 8 Filter levels 9 to 40dB
 - 3.5mm mono or stereo inputs
 - Speaker level and line level inputs - 7W mono speaker output and line level output
 - Headphone socket - Suitable for all types of radio incl' SDR
 - Easy to use controls for quick and easy operation
 - Enjoy clear "noise-free" speech

NES10-2MK4

- 5W amplified DSP noise cancelling speaker
- 8to 40dB noise cancelling
- Up to 65dB tone reduction
- Single switch switch for "Off" (audio bypass), "On" and "DSP" filter on
- LEDs for Power, filter on and audio overload
- Headphone socket
- Supplied with integral 2M audio lead, fused DC power lead & manual

New NEDSP1962-KBD 5W amplified DSP noise cancelling speaker retrofit module now available!



bhi HP1 wired headphones

New In-Line Module



- 8 noise filter levels 8 to 40dB - Tone reduction up to 65dB
- Bespoke 5W audio amplifier with latest bhi DSP noise cancellation - Audio bypass feature - 3.5mm mono inputs and outputs - Headphone socket - Audio input overload feature - DC power 10 to 16V DC - Compact unit, 135mm x 65mm x 46mm
- Replacement for ANEM MKII and NEIM1031MKII

Compact In-Line



- Powerful audio processor
- Lowlatency of 32mS
- Remove noise and interference
- Hear weak signals clearly
- Rotary encoders perform all functions
- Easy to use with "real time" adjustment
- Use with headphones or a loudspeaker
- 3.5mm line level and speaker level inputs

DESKTOP MKII

- Includes the latest bhi DSP noise cancelling technology for even better receive audio!
- 10W Amplified DSP noise cancelling base station speaker**
- Easy to use controls
 - 8 DSP filter levels
 - "Real time" adjustment
 - Suitable for all radios incl' SDR
 - Headphone socket
 - Speaker level and line level input sockets



bhi Ltd, Burgess Hill, RH15 9RR, UK

Tel: 01444 870333 - www.bhi-ltd.com



EA & O

Practical Wireless

Warners Group Publications plc
The Maltings, West Street
Bourne, Lincs PE10 9PH
www.warnersgroup.co.uk
Tel 01778 391000

Editor

Don Field G3XTT
practicalwireless@warnersgroup.co.uk

Designer

Mike Edwards
mike.edwards@warnersgroup.co.uk

Advertisement Manager

Kristina Green
01778 392096
kristina.green@warnersgroup.co.uk

Production Manager

Nicola Glossop
nicola.glossop@warnersgroup.co.uk

Production Assistant

Charlotte Bamford
charlotte.bamford@warnersgroup.co.uk

Marketing Manager

Katherine Brown
katherine.brown@warnersgroup.co.uk

Marketing Executive

Luke Hider
luke.hider@warnersgroup.co.uk

Publisher

Rob McDonnell
robm@warnersgroup.co.uk

Photocopies & Back Issues

We can supply back issues, but we only keep them for one year. If you are looking for an article or review that you missed first time around, we can still help. If we don't have the actual issue we can always supply a photocopy or PDF file of the article.

Technical Help

We regret that due to Editorial timescales, replies to technical queries cannot be given over the telephone. Any technical queries are unlikely to receive immediate attention so, if you require help with problems relating to topics covered in PW, please either contact the author of the article directly or write or send an email to the Editor and we'll do our best to reply as soon as we can.



SUBSCRIBE TO PRACTICAL WIRELESS



See page five for details of our latest special subscription offer
For further details call
01778 395161

Read on any device, anywhere, anytime at bit.ly/pw-sub22



Keep up to date on Facebook
www.facebook.com/radioenthusiasts



Follow us on Twitter
[@REnthusiasts](https://twitter.com/REnthusiasts)

Keylines

The December issue of *RadioUser* (RU) was, sadly, the last in its present format.

However, *RadioUser* lives on here in the pages of *Practical Wireless*. We have eight more pages each month, which will allow us to cover some of the topics that appeared over the years in *RU*. I have already been in contact with several of the regular contributors and here in this January issue of *PW* you will find articles on GMDSS and on broadcasting history, along with a broadening of our *News* coverage. There will be plenty more to come of general hobby radio interest to complement the hardcore amateur radio material! But, yes, rest assured, there will be no reduction of material on the amateur radio side of things.

Antennas

With the demise of *RadioUser* as a separate publication, we have been fortunate enough to 'inherit' **Keith Rawlings G4MIU** as a regular antenna columnist. His first column appears in this issue. But this month we also have a number of other antenna articles, from a discussion of the quad antenna to a split-coax dipole, a 10m horizontal loop and more. It never ceases to amaze me how there can be so many variations on antennas, given that they all, essentially, come down to the dipole, doublet or quarter-wave vertical. But do enjoy!

Reviews

We also this month feature some interesting reviews from books to products – maybe just in time for Christmas! And more reviews to come next month as we know they are always popular with readers. If there are specific products you would like to see reviewed, do feel free to drop me a line.

Take 20

I recently (December *Keylines*) mentioned the *Take 20* series from some years ago. I would love, as I said at the time, to resurrect this one but I have been unable to find a writer who has the time and the means to come up with a project on a regular basis. So here's a challenge! The task is to come up with a project that uses fewer than 20 components and, these days, costs less than £20. And to write it up as an article for the magazine. If a number of readers rise to the challenge, we have the makings of a regular(ish) series!

This Month's Historic Article

For this month's look back, I selected a project from the September 1940 issue of *PW*. This



was the first issue of *PW* to be published monthly – previously the magazine had appeared once a week. Quite amazing. The editorial in that issue said: "As announced in our last weekly issue, this magazine temporarily appears as a monthly magazine owing to the acute paper shortage. All newspapers are now rationed as to their paper supply, and the ration allowed for this periodical would not have made it an economic proposition as a weekly publication. We have, therefore, used our ration of paper to produce a monthly edition, and it will be observed that we have increased the number of pages. It is, however, essential for us to stress a point of great importance to every reader. It is this: Whether you have previously had a regular order with your newsagent for the delivery of PRACTICAL WIRELESS each week or not, you must now place an order with him for the delivery of this paper monthly".

So, a 'temporary' move to a monthly publication – some 82 years ago and still monthly! It is interesting to see, though, that *PW* managed to keep going during the war years, aided by an allocation of paper (albeit probably of poorer quality than had been available before the war).

There is just space for me to wish you all a very Happy New Year. It looks as though HF propagation is on the up, while more individuals and groups are heading out for contests, expeditions, community support activities, special event stations and more. Let's hope for a great year for the hobby.

Don Field G3XTT

Editor, *Practical Wireless Magazine*

Contents



11

3 Keylines

Don has news of changes relating to *RadioUser*, and talks of antennas and of the Take 20 series.

5 Subscriptions

Your guide to taking out a regular subscription to *PW*.

6 News

PW's monthly roundup of news from the UK and internationally, including new products, club news and recent events.

10 Review: Xiegu G106

Richard Constantine G3UGF looks at what he describes as "The 'friendly' little radio you simply want to use".

14 A Homebrew Quick-Release Towbar Antenna Mount

Daimon Tilley G4USI finds a solution to getting on the air quickly from his car.

16 The Face behind the Call

This month we meet a genuine pop star - Dave Rowntree M0IEG, drummer of top Britpop group Blur.

20 Coffee, the Andes & a Quad Antenna

Ray Howes G4OWY/G6AUW relates the story of the cubical quad antenna and describes how to construct your own.

24 Review: the Geochron

Don G3XTT takes a look at a smart and handy addition to the shack.

26 The World of VHF

Tim Kirby GW4VXE starts this month with a discussion related to the recurring VHF/UHF activity concerns.



34

30 Ahoy! BCS-GMDSS Decodes Eight Channels in a Row

Interested in receiving 3,500+ messages per day on HF on just six HF channels, plus smart features to control this ocean of logs? Then you must try Black Cat Systems' multi-channel GMDSS decoder! Nils Schiffhauer DK8OK is excited about performance and data handling.

34 Attenuators

Michael Jones GW7BBY asks "We spend a lot of time trying to make signals louder and receivers more sensitive, so why do we want a device to reduce the amplitude of a signal?"

42 An Instant Antenna for VHF FM

Rod Angel G4ZUP says "No antenna? No problem!"

45 The 14th Practical Wireless 70MHz Contest: Results 2022

Colin Redwood G6MXL presents the results of the 2022 contest.

48 The Short-Wave Three

Don G3XTT presents a project from the September 1940 issue of *Practical Wireless*, the first issue to reflect a move to monthly publication.

52 Data Modes

Mike Richards G4WNC follows on from last month's discussion of VarAC before moving on to MagicSDR and Simon's World Map.

55 Book Reviews

Don G3XTT looks at two new books from the RSGB.

56 10m Band Omnidirectional Antenna Design

David Allen G8LHD describes a neat omnidirectional antenna for the 10m band.

59 HF Highlights

Steve Telenius-Lowe PJ4DX has a packed column as DXpedition activity ramps up post-COVID and the CQ WW contest season gets into full swing.

62 Valve & Vintage

Tony Smith G4FAI narrates the history of Morse speed championships.

66 Loop the DX

Billy McFarland GM6DX advocates the use of a full-wave wire loop antenna.

68 Antennas

We welcome Keith Rawlings G4MIU as a new regular columnist on the important subject of antennas.

71 Vintage Television & Radio

This new column by Keith Hamer & Garry Smith will be featuring milestones in television and radio history, personalities, landmark programmes, and engineering achievements from a bygone era.

76 Rallies

Locate a rally or event near you; we have our usual comprehensive list.

77 Readers' Letters

This month's *Letters* cover conversational digital modes, licence revalidation and more.



66

Sign up to our FREE email newsletter at www.radioenthusiast.co.uk

SPECIAL OFFER!

ONE OFF PAYMENT SUBSCRIPTION



Detach along dotted fold, and return to the Freepost address. Thank you!
(Photocopies of this form are acceptable)

- No commitment
- Save Money
- Receive 12 monthly issues



MY DETAILS

Mr/Mrs/Miss/Ms

Initial(s)

Surname

Address

.....

.....

.....

Postcode

Please sign me up to a one-year subscription to Practical Wireless magazine, and send me 12 monthly issues for:

- £55 (UK) £78 (EU) £80 (RW)
- Cheque or money enclosed (made payable to *Warners Group Publications*)
- Please give me a call
- Please debit my VISA / Mastercard / Maestro

CARD DETAILS

Card number:

.....

Valid from: Issue No:

Expiry date: CVV No:

Signature

Date

We'd like to let you know about our latest offers. If you do not wish to receive direct mail from the publisher please tick here If you do not wish to receive direct mail from selected third parties please tick here

Email
I am happy to receive special offers via email from:
Warners Group Publications Selected third parties

Telephone
I am happy to receive special offers via telephone from:
Warners Group Publications Selected third parties

For information on how your personal data is processed, secured and your rights, our Privacy Policy can be viewed at warners.gr/privacy or available in hard copy on request. Your order will be processed in accordance with our Terms of Sale which can be viewed at warners.gr/termsale or available in hard copy on request.

HOW TO GET YOURS...

All you have to do is return the form opposite to the Freepost address below:

FREEPOST
WARNERS GROUP PUBLICATIONS
THE MALTINGS, WEST STREET,
BOURNE, LINCS, PE10 9PH

For a faster service,
subscribe by Debit or Credit card
at www.radioenthusiast.co.uk

Newsdesk

Have you got something to tell our readers about? If so, then email practicalwireless@warnersgroup.co.uk



Icom launch the IC-M510BB at METS

ICOM launched its new IC-M510BB at the METS (Marine Equipment Trade Show) in Amsterdam recently. An all-new top-end black box modular transceiver that can be installed out of sight for convenience or where space for electronic equipment is at a premium. Up to three remote control mics (the HM-195GB Commandmic) can fully operate all the features of the IC-M510BB and can be installed up to 18.3m or 60ft away from the main radio unit. The IC-M510BB is supplied as standard

with 1x HM-195GB but adding others will allow the user to control the 25W fixed radio from various areas on board such as the helm, chart table, cabin or flybridge. The IC-M510BB adopts many features from ICOM's market-leading NMEA award-winning IC-M510 VHF marine radio, including an AIS receiver which can be displayed on all three Commandmics or outputted to other devices or indeed a PC (EN 300 338-8 compatible). Also, hailer and horn functions are built-in and, of course,

integrated GPS. ICOM do not have a final fixed price or a release date for the IC-M510BB, but it is planned that it will be available from around April 2023. To pre-order, contact your local authorised Icom marine dealer. Alternatively, call the ICOM sales team on 01227 741741 or get in touch using the email address below. (SOURCE: Icom UK - sales@icomuk.co.uk)

<https://tinyurl.com/yufwjhw2>
<https://tinyurl.com/2p9h5dzv>

Tiny GS for Radio Amateurs

Jan Verduyn G5BBL PA3D, the Director of *SDR Kits Limited*, told us that simple satellite communications, using LoRa, is a very interesting area. It can be used by licensed radio amateurs, to receive short messages from other amateurs and for the reception of data from remote IoT devices and networks.

In this context, the *TinyGS* is an open network of Ground Stations distributed around the world

to receive and operate LoRa satellites, weather probes and other flying objects, using cheap and versatile modules. This project is based on ESP32 boards; currently, it is compatible with sx126x and sx127x LoRa modules but *SDR Kits* are planning to support more radio modules in the future. (SOURCE: SDR Kits)

<https://tinygs.com>



Sign up to our FREE email newsletter at www.radioenthusiast.co.uk



Moonraker Showroom Reopens

Moonraker report that their showroom is now back open after a temporary period offering just a 'click and collect' service. It has been re-configured, re-stocked and re-staffed so no

appointment is needed. Just come and browse or speak to one of the team members for expert help and advice.

Opening times Monday to Friday 9am - 5pm.

KW DAYS 2023: KW Days is a celebration of the UK's largest ever specialist amateur radio manufacturing company. It returns yet again at the start of the year and promises more special event stations than ever before.

All clubs are encouraged to take part in this annual Winter-Warmer, valve event. Although stations will be operating throughout the month, this year's main activity will take place on the weekend of 7/8 January 2023.

GB8KW will again be active from Cray Valley radio club's HQ in Eltham, showcasing a range of equipment and accessories made in Dartford from the 1950s to the 1970s. Visitors are most welcome and club members look forward to meeting friends old and new. In addition, GB5KW, GB4KW, GB2KW and GB0KWD callsigns will be active from other locations across the UK. Overseas owners will also be taking part.

The extensive range of KW made products has through the support of KW-Radios@groups.io become increasingly appreciated. This active group of collectors and ex-employees continues to provide help and support to those undertaking restorations and an extensive archive of manuals, circuits, and associated material continues to be curated.

Vintage KW AM and CW equipment will be found on VMARS or FISTS frequencies. Classic SSB equipment and in tribute to the famous KW77 receiver, will be using frequencies ending in 77kHz ± QRM. i.e. 1.877, 3.77, 7.177, 14.177 & 14.277, 21.277 and 28.377MHz.

AN-SOF Updates

The team at AN-SOF continue to be busy introducing updates and antenna models for their simulation package. The latest update is V7.8 as reported by AN-SOF. This is what is new:

- Quickly view input impedance, VSWR, directivity, gain and efficiency in the new Results tab.
- Click the Export Results button on the toolbar to export this data to a spreadsheet.
- The wavelength is now displayed in the Frequency panel while entering the operating frequency.
- Automatically close all charts when exiting AN-SOF or keep them open to analyse the plots.

Go to Tools > Preferences > Options and check 'Close charts when exiting AN-SOF'.

A great strength of AN-SOF is the documentation. Explore the new User Guide on the website. Coming soon: the online Knowledge Base. Recent additions to the model library have been a 4-element broadband directional antenna. More than 50MHz of bandwidth (SWR < 1.5) around 285MHz. Gain 7 to 8 dBi. Length 0.52m and maximum width 0.6m. The driven element is shaped like a double arrow and has a folded

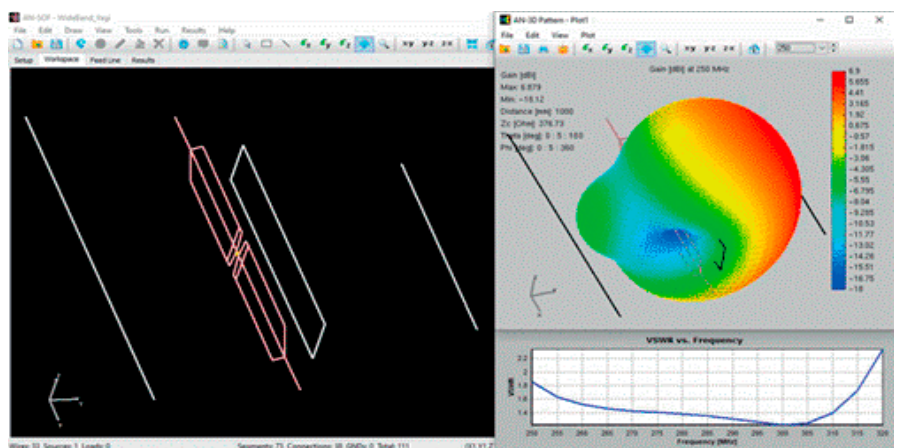

parasitic element right in front of it. Does anyone know the author of this design? Download:

<https://tinyurl.com/bdzzaahy>

Next, there is a relatively compact 4-element bi-quad array model that resonates at 434MHz. The wires that connect the driven element to the reflector work as a two-wire transmission line that allows the user to obtain an input impedance of $50 + j0$ Ohm. So, this design can be fed directly with a 50Ω coax.

- Bandwidth 4% (VSWR < 2) | Gain 12dBi
- Beam width 50° | F/B 21dB
- Slices H and V of the radiation pattern show that it is very symmetrical.

The polar plots are on a log scale. ARRL-style log scaling is coming in the December release of AN-SOF [...].

(SOURCE: AN-SOF | via Keith Rawlings)

<https://antennasimulator.com>

Read more radio news and reviews at www.radioenthusiast.co.uk/news

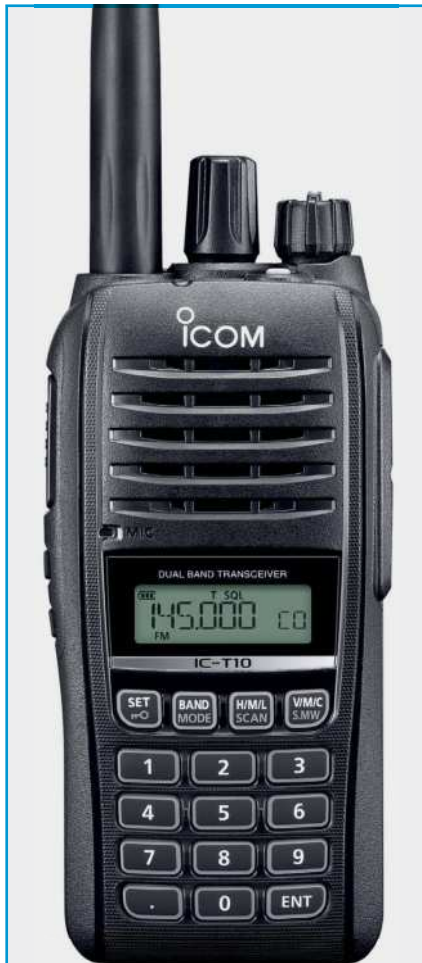

ICOM:IC-T10 VHF/UHF Dual-Band FM Transceiver

The new, rugged, Icom IC-T10 5W VHF/UHF dual-band Amateur handheld radio from Icom is now available from authorised Icom dealers with a suggested retail price of £199.99 including VAT. Designed with an IP67 dust-tight specification and waterproofing rating, the IC-T10 is a simple yet powerful dual-band handheld. The radio features a clear, easy-to-use layout, rugged commercial build, 1500mW loud audio and long-lasting Li-Ion battery life making it an ideal radio for beginners and seasoned Amateur radio enthusiasts. For further information on this new radio, and to view a video introduction, click on the links below:

(SOURCE: ICOM UK | Ian Lockyer)

<https://tinyurl.com/5y4a8xku>
<https://tinyurl.com/d5chjs5z>

Practical Antenna Models

Volume 3

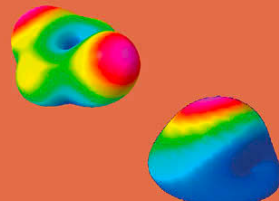

Marcel De Canck, ON5AU

Practical Antenna Models

Readers will probably recall that in the past we have reported on the series of books written by **Marcel ON5AU** which cover the fascinating subject of antenna modelling. The first in the series of these books was titled *Advanced Antenna Modelling*, and this hefty tome gets to grips with antenna modelling using EZNEC and AutoEZ. Despite its title it starts with the basics and works up to some very advanced techniques, walking its reader through the various methods used in a series of detailed chapters and this book is a must for the serious antenna modeller. Following on from this book Marcel produced *Practical Antenna Models Volume 1*. This book has chapters on Antenna Fundamentals and Dipoles.

Following on from this, *Practical Antenna Models Volume 2* was published dealing, in the main, modelling Verticals but also has details on modelling towers and Matching Circuits. Marcel is pleased to announce that *Volume 3* has now been published covering Loops and Matching methods. Like the previous volumes this book is full of information on how to correctly model – in this case loops – using EZNEC and also programming AutoEZ to get the utmost out of EZNEC. The previous volumes all have downloadable data to complement each chapter and Vol 3 is no exception, having 410 EZNEC and AutoEZ model files ready to use. With these models available 'pre-built', this saves the reader the job of entering them into the software. Naturally, these files may be edited and altered at will. This volume is another 'must' for the serious EZNEC user. (SOURCE: <https://tinyurl.com/5c9trffw> via Keith Rawlings)

RSGB CONVENTION ONLINE: The RSGB have added timecodes to the RSGB Convention livestream recordings to help you find the presentation you would like to hear. Head over to the RSGB YouTube channel:

www.youtube.com/theRSGB

RSGB President Stewart Bryant G3YSX and General Manager Steve Thomas M1ACB were interviewed at the National Hamfest by ICQ Podcast. Steve talked about this year's first hybrid RSGB Convention, which brought hundreds of people together again. The two days of livestream content attracted thousands of views from radio amateurs across the world over the weekend and people are continuing to enjoy the presentations.

The President also discussed the RSGB's international and standards work with the IARU, as well as the need to use and protect spectrum. These were issues that were covered by the IARU President Tim Ellam VE6SH/G4HUA in his RSGB Convention keynote presentation.

The RSGB has also launched this year's construction competition. To enable members across the country, and even the world, to enter, entries will be judged over the internet rather than in person. There are four categories – Beginners, Construction excellence, Innovation, and Software – and the deadline for entries is 1 March 2023. Special recognition will be given to entries submitted by radio amateurs under the age of 24, and to those who have just gained their Foundation licence. A cash prize will be awarded for the winner of each section, with a bonus for the overall winner who will also be declared the winner of the Pat Hawker G3VA Trophy. To find out more, including how to enter, see the full details on the RSGB website at:

<https://tinyurl.com/3x5t6prd>

SECRET GENIUS OF MODERN LIFE: A recent BBC Two series is called '*The Secret Genius of Modern Life*'. The RSGB was approached to find experts to contribute to two of these episodes. For the first episode in the series, Neil Smith G4DBN re-created the Great Seal Bug, a wooden seal, gifted to the US embassy in Moscow in 1945 and which contained a covert listening device. The technology developed for the bug was an early example of RFID, which is what allows contactless card payments to work. You can watch the series on BBC iPlayer.

MORSE TEST COORDINATOR: The RSGB has appointed Eric Arkinstall MOKZB as its Morse Test Coordinator. Eric has been interested in electronics since he was young and built his first crystal set when he was about 11 years old. Eric now teaches Morse code on the air each week. For further information about Morse and the Morse test, see the RSGB website at:

rsgb.org/morse

Sign up to our FREE email newsletter at www.radioenthusiast.co.uk

OT NEWS: The winter edition of *OT News*, the journal of the Radio Amateur Old Timers' Association includes an overview of their experience running the club stand at the Newark 2022 Hamfest, and a selection of photos taken at the show. There is another in the series of Morse keys made from Meccano by G4GQL, a quiz by GM4FZH, and a couple of cartoons. GOTUD discusses whether Linux is now a viable alternative to Windows for amateur radio; AJ8B describes his 'no excuses' topband vertical, and M0IRS gives details of his end-fed aerial for small gardens. G3WAG asks what amateur radio actually is, while G3ZPF relates his surprise at finding his call sign on an Ofcom list of 'prohibited' suffixes and discusses why this change may have happened:

www.raota.org

WIRELESS FOR THE WARRIOR: Godfrey Manning G4GLM reports that *Wireless for the Warrior* (Meulstee, mentioned recently in our *Valve & Vintage* column) is still in print. Wimborne Publishing changed hands and is now known as Electron Publishing, whose primary title is *Practical Electronics* (also changed recently from *Everyday Practical Electronics*). They advertise *Wireless for the Warrior* in four volumes, to order call 01202 880299 (or see website).

<https://tinyurl.com/2bajh2c4>

QSO TODAY VIRTUAL HAM EXPO: All of the 370+ presentations made since August 2020 at five QSO Today Virtual Ham Expos are migrating to a dedicated YouTube Channel:

www.youtube.com/@qsotodayvirtualhamexpo

A few videos are being uploaded on a daily basis, until the entire catalogue is on YouTube.

SPACE RAIN DROPS SPLASHING ON EARTH'S MAGNETIC UMBRELLA: Every few minutes, Earth-sized 'droplets' of plasma rain down from space toward Earth. Instead of crashing catastrophically to the ground, these droplets, called magnetosheath jets,

hit and are deflected by the outer reaches of Earth's magnetic field. Despite their frequent occurrence near Earth and likely ubiquity across the solar system, the study of magnetosheath jets is young, and there is much we do not know about their origins and behaviour.

Specifically, their potential effects on space weather—the phenomena we experience on Earth due to the ever-changing stream of plasma that flows through our solar system—are unclear and still being investigated. Therefore, these jets are not currently factored into space weather models or predictions. Read about this ground-breaking propagation research at the URL, below (Credit: Advanced Visualization Lab, National Center for Supercomputing Applications, University of Illinois, Urbana-Champaign (National Science Foundation Award 1445176).

(SOURCE: AGU EoS Buzz NL; 14th October 2022: agu@agu.org | aguservice@agu.org)

<https://tinyurl.com/yt8vebeb>

AMATEUR RADIO MENTIONED IN 'POWERBOAT AND RIB' MAGAZINE: Peter Talbot G5AIB is featured in the Nov/Dec issue of *Powerboat and RIB Magazine* in an article about small boat adventuring. Peter mentions how useful amateur radio is for his adventures and how he combines his interest in SOTA with boating in places like Windemere. You can read the full feature if you sign up for the free digital edition:

<https://tinyurl.com/36xz5z3b>

UNIVERSITY STUDENTS LEARN ABOUT AMATEUR RADIO SATELLITES: In India on the occasion of *National Engineering Day*, an excellent Workshop titled '*Fascinating World of Ham Radio and Amateur Radio Satellites*' was conducted by AMSAT-INDIA's Regional Coordinator Rajesh Vagadia VU2EXP at reputed Marwadi University Rajkot (Gujarat), India [...]. It was a half-day, interactive, workshop full of

presentations, Audio Visual documentaries, Practical demonstrations, Q&A sessions, and radio exhibitions, with some live operation. All participants gained knowledge on a broad spectrum of topics from CW to Cube Satellites! In the first session, radio fundamentals, operating protocols, radio jargon, licensing procedures, and so on, were covered. In the second session, participants were briefed about various Ham radio events like FD, Hilltop, Light House activation, POTA, IOTA, EME, Satellite tracking, SatCom, High Altitude Balloon tracking, ARISS SSTV & Student outreach program which gives exposure to gain knowledge & develop skills from outside radio. (SOURCE: ICQ / Amateur Radio Podcast)

<https://tinyurl.com/5xuwx3nh5>

RADIODAYS IN NORTH AMERICA: *Radiodays Europe* is expanding to North America with a brand new conference planned for Toronto in 2023. Radiodays North America will be held in association with the *Canadian Music Week* conference on June 8th and 9th 2023, at the *Harbour Castle Westin Hotel* on the shores of Lake Ontario as part of the week-long *Canadian Music Week Festival*. Peter Niegel, General Manager for Radiodays Europe says: "We are thrilled to be able to bring the *Radiodays Europe* brand and its expert international content to North America. Toronto is the ideal location to bring everyone together to ensure that we as an industry move forward with strategies for the future." [...] Keynote speakers and expert panellists from North America and around the world will be in Toronto to discuss and strategize all aspects of over-the-air and digital broadcasting. From broadcast to a podcast, everything is on the table: Executive leadership, workplace diversity, innovation, technology, talent, programming, marketing and how to grow your audio revenue will be on the agenda. (SOURCES: RadioToday WORLD | admin@radioday.co.uk)

www.radiodaysnorthamerica.com

Antenna Collection Archive CD



A PDF archive of Practical Wireless antenna reprints since 1981

From
£14.99
plus P&P

Buy it now from bit.ly/antenna-collection



Bowood Electronics

Unit 10 | Boythorpe Business Park | Dock Walk | Chesterfield | S40 2QR

01246 200 222

sales@bowood-electronics.co.uk

www.bowood-electronics.co.uk

PASSIVE COMPONENTS | SEMICONDUCTORS
OPTO | PCB MATERIALS | ENCLOSURES | ETC



Practical Wireless Rating



A great radio, with lots of future potential.

Richard Constantine G3UGF
practicalwireless@warnersgroup.co.uk

When I first handled this new curve sided radio, its futuristic appearance reminded me of vintage TV series of the 1960s and 70s. Know what I mean? People in white jumpsuits, headsets, low budget scenery and sci-fi noises from wobblers and sine/square wave generators.

The G-106 definitely isn't flimsy, it's reassuringly solid. It's a little heavier than it looks at 733 grams and measures just 120mm wide x 40mm in height x 135mm deep.

It's smaller than a Yaesu FT-818ND as it has no internal battery and, of course, it's half the price.

The 'groovy', stove finish casing is quality steel and extends at each front corner to protect the external controls, very handy when out and about.

Out of the Box

Unpacking and handling the new Xiegu G106 makes you really want to play with it and to find out just what it can do.

Firstly, it's a 16 bit-CODEC, SDR design with receive capability from 0.55-30MHz, plus 88-108MHz, wide bandwidth FM broadcast reception.

It's capable of transmitting SSB & CW as it stands. It's also prepared for both lower and upper sideband data operation (with the small, optional DE-19 interface not shown) on amateur

The Xiegu G106

Richard Constantine G3UGF looks at what he describes as "The 'friendly' little radio you simply want to use".

bands from 80-10 metres, including WARC bands. There's also a portion of 5MHz – more on that later.

The copied handbook initially appears somewhat basic in certain areas. Having studied it at some length, almost everything you need to know is actually there.

In version 1.0 firmware, the AM transmit mode was inhibited. I'm pleased to report that in the latest V1.1b01(EN) firmware it's now included with quite a few other features that I'll also mention. A downloadable 'how-to' firmware upgrade guide is available on the Xiegu website:

<https://tinyurl.com/mr2rxw8t>

Xiegu describe the radio as, "An entry level, portable SDR transceiver, G-106 will be a good helper for you to play CW and FT8."

From this you can take it that it's perhaps not intentionally aimed at the main station shack market. To my mind it's better described as a cost-effective alternative for portable activity and for PC linking/data use. It's around one quarter of the price of an Icom IC-705 and a fifth the price of an Elecraft KX3.

That said, it is by no means basic, in many

respects. Yes, I could list all the things it doesn't have but that would be unfair. I'm more interested in the wealth of features and options it does have.

RF Power & Modulation.

The only band I found the power output of 5 watts carrier to be accurate as per book was 5MHz. All other bands were typically between 8-9 watts, into 50Ω. For some reason 24MHz produced 11 watts. The radio doesn't have an on-board speech processor but with the latest firmware it does have microphone gain settings. Settings are displayed as 0-30, that is, from 0 to 15db in 0.5db steps. With the gain set at the handbook default of 20, peak reading SSB meter results were similar to key-down at around 8 watts, with 24 and 28MHz highest producing 10 watt outputs.

Now for the likes of serious UK, QRP operators, low power is 5 watts. At the time of writing, there's no power control option but, I have it on good authority that variable power is coming. For now, many users may consider the extra watts a bonus!

Modulation is clean and crisp from the electret

Sign up to our FREE email newsletter at www.radioenthusiast.co.uk

Photo 1: The front and top panel. Photo 2: Rear View. Photo 3: /P Fun on a foul day in my van. Photo 4: G106 and XPA-125B 100W amplifier (see PW March 2021).

hand microphone, but don't expect an on-board equaliser at this price. Not that I'm a fan anyway. The internal CW keyer can be set to manual, lmbic A and B etc. Speed control is accessed from the 4-button front panel menu system (see later). If you want to change keyer speed to match your contact, you have to be a bit nifty to set it up while the other guy is sending but it's not too much of a problem, once you get the hang of it.

The radio can be adjusted to step directly from one amateur band to the next, using the top mounted Up/Down buttons or as a general coverage receiver.

There's no rotary RF gain control, how often do you need one? There is a fixed gain pre-amp, accessed by holding down the top-centre Mode button. Ditching voltage and power ratio calculations that you can learn all about online if you're not familiar with them, the real-world effect is around 9-12dB across the range, that is just about two S points to me and you, give or take QSB.

High Gain Receiver

Previously, I indicated that this is a radio intended primarily for portable use. Therefore, it's reasonable to assume that in most cases antenna setups will be some form of compromise. This radio's front end, in common with most of the Xiegu range, has an exceptionally high-gain RF amplifier for this purpose. Rx sensitivity is on a par with others at $0.25\mu\text{V}$ for 10dB S/N CW. SSB is a little lower at 0.5dB but perfectly acceptable in operation.

I was initially surprised when I connected it to a random 30m, non-resonant long wire that at some times of day (especially LF bands at night) the radio was simply overwhelmed. Using a frequency band specific, coaxially fed antenna largely cured the problem. Out and about using a resonant single band vertical or inverted-V it wasn't an issue.

5MHz

I have an interest in 5MHz. I think it has an as yet, largely unexplored potential for amateur use. The military have long known its potential, hence they remain somewhat reluctant to give us more space.

Xiegu have rightly engineered their 5MHz capability to match the WRC-15 bandplan, ratified by IARU back in 2017. This doesn't correspond with the current UK allocation. Indeed, at the moment you can't use the QRP CW frequency of 5.262MHz. All operators need to be very careful elsewhere so as not to contact other countries



outside our allocation. See the RSGB bandplan for details. My source tells me that the factory in China is aware of the UK dilemma and a fix may be with us very soon.

Operation and Options

First of all, the 5cm (2in) LCD monochrome, backlit display is clear and clean in appearance. Even in fairly strong light, the frequency readout is easy to see. The light can be turned off by a quick push of the On/Off power button. In normal operation the display presents the user with readout of mode, A/B VFO frequencies and a bargraph S meter. The screen also indicates VFO or memory in use. There are 50 memories to fill, ideal for beacons and spot frequencies.

The very useful panadapter that I wouldn't want to be without these days, is displayed across the bottom of the screen and is a centre fixed type. It can be toggled between covering the amateur band or as they describe it, the "Full band." You can also opt for a larger "Big Scope" display.

The tuning rate is fully adjustable, by holding down either the Up or Down band button for two seconds. This moves the rate from one tuning step to another. The current rate can be seen by the highlighted digit on the display. It's the one with the border around it.

In TX mode the S-meter becomes a comparative modulation or keying indicator and it's also visible on the panadapter.

Four Magic Buttons

What do the four buttons below the screen do? Well from here on they control just about everything else that's not on the top edge of the radio, once you learn the acronyms. They put me in mind of how Yaesu's FT-817 works.

Pressing any key replaces the panadapter with four headline menu options, one for each button. Rotating the VFO dial reveals another set of four and so on. In all, there's a potential for 20 headline options. One or two remain vacant, waiting for future upgrades, if and when.

Read more radio news and reviews at www.radioenthusiast.co.uk/news

Pressing the option button of choice reveals a further sub-menu. A few are simply on or off choices, while most are further customisable.

There's no VOX facility but there is QSK break-in for CW. Once or twice I was just able to bounce (get ahead) the break-in at high speed settings. Ratios are adjustable but I would suggest that it's better to think in terms of near semi-break-in operation. It's not a problem and neither is the small click from the keying relay, unlike some radios I know. The sidetone frequency is adjustable. The radio has switchable and effective receive bandwidth CW filters.

At the outset I said that this radio is by no means basic. It certainly isn't in many respects. Once you study the handbook matrix of the options available through the four magic buttons, just about everything you need for every mode, including data, is available.

In the early stages of ownership, I would recommend carrying a laminated print-out of the Multi-function Menu system, if not the 25-page handbook.

The radio has an internal speaker that I would describe as perfectly adequate, if a little on the tippy side, due I think in part to the robust metal casing. However, something unexpected is that this radio doesn't have a conventional 3.5mm external speaker socket on the rear panel. At first this really threw me off course.

I discovered almost by accident that pressing the volume knob switched the audio to the microphone. Then and only then could I attach my headphones to the 3.5mm socket at the base of the hand microphone. The socket's dust cover doesn't swivel out of the way making it a bit of a fiddle to connect the plug. While the socket requires use of a stereo connector, you only get sound in one ear when using stereo headphones. You either need to use switched types or strap both leads together for full effect.

Tip: The 4-pin RJ type Speaker/Microphone socket pin-outs are shown in the handbook. This makes it relatively easy for a user to make up a simple PTT breakout box for a headset and electret boom microphone – first thing I would do.

Data and Accessories.

Thus far I've been considering the stand-alone use of the radio. In common with other Xiegu models and design philosophy there's potential to use the radio with their XPA-125B 100W amplifier, computer control and data communications.

The standard 8-pin accessory socket on the rear of the transceiver provides waveband data voltage signals. The values for band switching or controlling peripheral devices are listed in the handbook.

With the option to purchase the DE-19 interface adapter that's supplied with four



3



4

interconnecting leads, it becomes a simple plug-and-play operation to connect a computer and/or the XPA-125B linear amplifier. The handbook recommends the installation of a CH342 port driver and use of the same datacomms software as per their G90 radio.

Impressions

I had every intention of opening this radio up for readers to see its internal workings and was kindly given permission to void its warranty sticker. However, I can do better than that.

This radio has a clean bill of health from the FCC and carries its own approval number: 2ANLH-G106. The complete test report is available online. The report includes a full set of photographs of the high-quality internal workings. Look on-line and judge for yourself if the radio is for you:

<https://tinyurl.com/bdh2azmu>

I've had fun with this little box and enjoyed using it and discovering its potential, both at home and out in the field. In terms of value for

money, it has no real comparison other than with models from the manufacturer's own range.

I would describe it as a sort of, compact, 'friendly' little radio that you simply want to use, and especially good for a little casual portable. The deceptively simple looking front panel hides a wealth of useful features and functions. It has to be 5-stars for value as it certainly won't break the bank.

In addition to SSB and CW it can be used as a monitor or data radio, without tying up the main station. Having taken time to understand it and not rush to judgement, I can say that for now it's a good 4-star radio in its present form and with free, downloadable firmware upgrades on the cards, that value can only increase.

I would like to thank the team at Nevada and Waters & Stanton for not only the kind loan of the review radio but also for responding very promptly to all my many technical enquiries.

At time of press the Xiegu G106 Radio sells for £349.95, while the DE-19 Data Interface costs £49.95. **PW**

Sign up to our FREE email newsletter at www.radioenthusiast.co.uk

Visit our Book Store at www.radioenthusiast.co.uk

RADIO ENTHUSIAST BOOKSHOP



Practical Wireless Archive CDs Available to Order

All issues of Practical Wireless published over the nominated periods, are now available on a handy CD-ROM.

Practical Wireless
2022 Archive CD

12 issues of PW

From **£23.99** plus p&p



Practical Wireless
2021 Archive CD

12 issues of PW

From **£23.99** plus p&p



To order, visit www.radioenthusiast.co.uk or call **01778 395161**

Browse our best sellers at: bit.ly/bestsellers21

Daimon Tilley G4USI

practicalwireless@warnersgroup.co.uk

Being the father of two teenage boys means I still undertake a lot of 'Dad's Taxi' work. I recently purchased the Xiegu G90 I had for review, to allow me to quickly and easily undertake both CW and SSB work from the car while parked and waiting for the kids. So far I have been using the rig with a Ham-Stick type antenna for the 20m band using a mag-mount. Not wanting to buy a multiple of these antennas I have cheated and used the internal ATU of the G90 to tune the antenna to both 30m and 17m, but this is not very efficient, even though I have had plenty of European contacts this way.

I was aware that MFJ produce an antenna called the MFJ-1979. This is a 16ft telescopic stainless-steel whip that shrinks (telescopes) to just over 2ft long. They are not cheap at about £70, but much quicker and more convenient than putting up a fishing pole and wire, and more efficient than my Ham-Stick, being a full quarter wave at 20m. You can also telescope the antenna down to find perfect resonance at the higher bands too. But two issues presented themselves. First, no-one has had the antenna in stock for ages, and second, my little VHF mag-mount will certainly not be man enough for the job.

An Alternative

After lots of internet research, I found on one of my favourite Chinese marketplace sites an almost identical antenna at just over £20 posted. I ordered it and it arrived in less than a week, very well packaged, from Hong Kong.

So that was the first problem solved, now what about the mount? I didn't want to buy a three-magnet type mag-mount because I have a 4x4 with a ridged roof, so one of these will not have great 'purchase' and also, trying to extend and alter the length of a 16ft whip on top of a car that is over 5ft tall was just not going to be pretty!

I do have a fixed towbar and first considered bolting some aluminium angle to it with a 3/8in antenna stud as a permanent fixture. However, I would need longer tow-ball bolts and I was not convinced it would not be in the way when towing.

More internet research led me to discover a type of quick-release clamp used in the stage-lighting/disc-jockey world that would accommodate the 33mm diameter swan-neck. Mine was called, wait for it, "Duratruss Jr Eye Clamp Half Coupler 32-35mm Clamp Truss Rigging 75kg" and cost me £7.99 with free postage from eBay. See Fig. 1 for a picture. It can be seen that this has a lifting eye attached, but I removed this easily and cut and drilled a small length of scrap aluminium angle I had in the garage. I rounded off the pointed corners on my bench-grinder, drilled a hole for the CB type



A Homebrew Quick-Release Towbar Antenna Mount

Daimon Tilley G4USI finds a solution to getting on the air quickly from his car.

antenna mount and another, in the centre, to place a bolt through the quick release bracket. I torqued up this bolt tight and used thread-lock to keep it secure. Tests revealed it can be placed on the towbar in less than ten seconds, tightens up very securely and is more than rigid enough for the job. I now plan to add a small stainless-steel bolt with a wingnut to the other side of the angle so that I can quickly attach a few radials. Add a length of coax with PL-259s at both ends and you are ready to operate.

The pictures should speak for themselves, but

for £12 (£8 for the clamp and £4 for the CB stud) and a piece of scrap aluminium from the garage, I now have an excellent quick and easy antenna mount. I plan to make a second one, but this time with a long vertical section of aluminium angle, that I can use to mount my 10m fishing pole to when I wish. Happy building! **PW**

Fig. 1: The quick-release clamp.

Fig. 2: Top view with 3/8in antenna stud fixing.

Fig. 3: The antenna in position. Fig. 4: A final view showing the connector for the coax.

Sign up to our FREE email newsletter at www.radioenthusiast.co.uk

Rugged, Compact Dual-Bander!



- 5W RF output in 144 and 430MHz.
- Large speaker provides 1500mW loud and clear audio.
- Dust-tight and waterproof to IP67.
- Up to 11 hours* operation with supplied 2400 mAh (typ.) Li-Ion battery pack.
- Home button provides quick access to calling channel.
- FM broadcast receiver.
- Built-in CTCSS/DTCS
- 16 DTMF autodial memories. Priority, program, memory, skip and tone scan capabilities.
- Free downloadable CS-T10 programming software.

VHF 11 hours, UHF 10 hours (approx.) at 1:1:8 duty cycle operation at 5W output power. (With power-save function ON).





Roger Dowling G3NKH
practicalwireless@warnersgroup.co.uk

When we launched this series a year ago its aim was to demonstrate that radio amateurs are drawn from all walks of life and often have interests and talents that might not always be apparent from a quick QSO on the air. And so it has proved. We have already met a talented organist, a top radio astronomer, a regular BBC broadcaster and a world-renowned novelist.

This month we break yet more new ground. I am delighted to have the opportunity of talking to **Dave Rowntree M0IEG, Fig. 1**, drummer of the globally famous Britpop group Blur, **Fig. 2**. Dave has had a lifelong fascination for radio, which – as we shall learn – is the inspiration behind his debut solo album *Radio Songs*, **Fig. 3**, due to be launched this month.

So how did the interest in radio develop? “It really came from my father”, said Dave. “He took a degree in physics and then did his National Service as a radio engineer in the RAF, which gave him an abiding love of electronics.

The Face behind the Call

Roger Dowling G3NKH meets Dave Rowntree M0IEG, drummer of top Britpop group Blur.

He then went on to join the BBC as a studio engineer and manager at Broadcasting House. Then, in his later years, he became part of the computer revolution as the BBC installed massive mainframe computers to run its payroll operations”.

As a youngster growing up in Colchester, Dave would spend hours with his dad building radio kits at the kitchen table. “We’d tune into stations all over the world using an antenna strung around the back garden and I’d often wonder what life was like in these faraway places.”

Love of Music

Dave’s parents, both musical themselves, also instilled into him a love of music. His father was a semi-professional singer and his mother was played the viola in one of the London

orchestras, a rarity in the male-dominated 1950s, before herself moving to the BBC.

Meanwhile, Dave’s first ambition was to be a classical percussionist and join an orchestra – despite the advice of his parents who assured him no good would come of it. He attended normal school during the week and the Landermere Music School near Clacton at the weekends. From school, he studied for a Higher National Diploma in Computer Science, and started his life as computer programmer for Colchester Borough Council. He had continued to play drums at every opportunity and joined Colchester Silver Band, which gave him a lifelong love of brass instruments. Then, when he was 14, he discovered drum kits, pop music and girls, so his earlier interest in classical percussion took a back seat.

Sign up to our FREE email newsletter at www.radioenthusiast.co.uk



Fig. 1: Dave MOIEG with his Flex 6400 and display. Fig. 2: Blur: the early days. Fig. 3: Radio Songs album. Fig. 4: Space exploration: Elk yagi and Yaesu VX-8. Fig. 5: Alex James with Dave at Houston Space Centre.

Blur

Britpop legends Blur – singer **Damon Albarn**, guitarist **Graham Coxon**, bassist **Alex James** and drummer **Dave Rowntree** – was formed in 1989. “We’d all played in bands before and I had known Graham from my schooldays”, said Dave. The musical chemistry worked, and since their formal debut in 1991, Blur have released eight studio albums, six of which reached number one on the UK Albums chart. To the delight of fans, the band have now announced that they will be performing two headline reunion shows at the iconic Wembley Stadium on 8-9 July 2023. It will mark their first gig together for eight years and will see the band perform its greatest hits.

Amateur Radio

Meanwhile, Dave continued to be interested in all aspects of radio and electronics. A hiatus in Blur gigs around 2015 gave him the opportunity at last to investigate the possibility of acquiring an amateur radio licence. He began by enrolling on the excellent Foundation and Intermediate training courses run by Bromley & District Amateur Radio Society (BDARS), as a result of which he acquired the Foundation call sign **M6DRQ**.

“To get my full licence, I took the Bath Based Distant Learning Course run by Bath & District Amateur Radio Club”, said Dave. “It was really well run, with lots of feedback, encouragement and mock papers. By the end of the course I felt totally confident that I was going to pass.” Dave was indeed successful and soon acquired his full licence MOIEG.

Like most amateurs, Dave has acquired what he describes as a ‘mishmash’ of gear over the years but his main HF transceiver is the highly



regarded Flexradio SDR-based 6400 working into a simple dipole, together with a Yaesu VX-8 into an Elk Antennas portable log periodic 144/440MHz Yagi for satellite work and for use on the road using a loop antenna, Fig. 4.

Read more radio news and reviews at www.radioenthusiast.co.uk/news

Space

Satellites are one of Dave's particular interests these days and I asked him how this had come about. "I've always found space endlessly fascinating", he told me. "I always had an interest in astronomy alongside my interest in electronics and amateur radio." Back in 1998 this led to involvement in the Beagle 2 Mars mission, which aimed to look for evidence of past life on Mars. Dave had visited the NASA space centre in Houston, **Fig. 5**, with Blur bass player Alex James, and they were concerned that all the space research was being undertaken – often with British staff – over in America. They joined the Beagle team to help to promote the UK Beagle 2 project, which eventually secured the support of the UK government and the European Space Agency. The Mars Express mission, carrying Beagle 2, was finally launched in June 2003, carrying a signature tune written by Blur to be beamed back to earth to announce its arrival.

Sadly, Beagle 2 lost contact with earth, though it was located on the surface of Mars in 2015 when it was found that two of its solar panels had failed to deploy. "But we can still claim that we got the first music on Mars", said Dave philosophically.

Solo Album

In January 2023, Dave will be launching his first solo album. While over the years he has provided backing vocals on many of Blur's albums and on-stage during their live sets, this is the first time Dave has stepped up to the microphone as a singer in his own right. "The idea of Radio Songs is me spinning through the dial", he explained. "It sounds like you've got a radio tuned to some static and then, when you spin the dial, the songs pop out of it. And then, you spin the dial again and the songs dissolve back into the static." Each of the songs finds Dave exploring significant turning points in his life – like '1000 miles', which is a ballad expressing the difficulties of world-travelling musicians in sustaining relationships, and 'HK' which includes cut-up recordings of radio broadcasts Dave had captured in Hong Kong when Blur were there in 2015 making their *The Magic Whip* album.

Other Interests

Dave has many interests beyond radio and space. His background in computing led him into computer animation and for many years he had his own company whose clients included Channel 4's *The 11 O'Clock Show* and *Empire Square*. He also works in film and television soundtrack composition where his work includes the BBC crime thriller *The Capture* and the Netflix science fiction series *The One*.

He holds a full pilot's licence and is part-owner of a Cirrus SR22, which he uses regularly for touring commitments.

But the interest in radio remains as strong as ever. "It has been a constant for me", Dave told me. "It's been one of the steadying factors in my life." **PW**



Sign up to our FREE email newsletter at www.radioenthusiast.co.uk



SEASONS GREETINGS



 PHONE

 ONLINE

 INSTORE

www.moonrakeronline.com

T: 01908 281 705 E: sales@moonraker-group.com

SCAN TO SHOP



Ray Howes G4OWY/G6AUW
g4owoy6@gmail.com

Isn't it lovely when it's getting more summery? There I'll be waddling about in my garden wearing my old Levi jeans and my Save the Ionosphere tee-shirt on while admiring the Flora, maybe checking out the fruit trees and watching the insect fauna as they dart here and there. And perhaps updating my antennas. I'd swan about feeling like Jack-the-lad just muttering about nothing at all. Well, I might wonder why I'm so OCD? Why a friend of mine insists on calling SDR 'Silly Defined Radio'? And why my local amateur radio community appears to have packed their bags and left for pastures new? Anyway, as I usually do, I plonk myself down inside my summer house, crack open a can or two of Carlsberg Export and think how sweet being outdoors really is. This is the life, me thinks. It's not something I'd contemplate doing during winter-time. No. I peer out of a window instead, watching my antennas battling the winter winds. Keeping my fingers crossed!

Mentioning being outdoors, when Uncle Sol has got his hat on, now and again I pack up my radio gear and operate in the big wide outside. However, I always try to find a place where people don't congregate in large numbers. Particularly when hordes of school kids are likely to be running riot for six weeks. So, I need to find a quiet spot. Mind you, that tactic doesn't always work. Because occasionally, there I'd be yapping into a microphone or giving my Morse key a good workout when a bunch of curious onlookers descend like a flurry of hungry vultures (as happened a few months ago) asking, "what are you doing?". Or, "why are you doing it?". Questions, questions, questions. I guess I have to do my bit, step up to the plate and promote the hobby, so I shut down to dispense some amateur radio wisdom. How it all began, how important amateur radio used to be. And no, it needn't be an "expensive hobby", I reply. "Can anybody buy that sort of radio and start talking?" No. "Can I have a go?" No. "How far can you reach?" "On a good day, the South Pacific" to gasps of incredulity. "On a bad day, from Weymouth to Dorchester". "How far is that?" chimed a couple of adults, seven miles. "So why is that?" they opine. "Depends on ionospheric conditions and so on", says I. "What does that mean!?" At which point, a small boy chirped up: "dad, our teacher mentioned the ionosphere to me and my classmates a couple of weeks ago". That shut them all up for a while.

I gave this lad one of my posh QSL cards, which featured the first Pitcairner amateur, **Andrew Young**, **Fig. 1**. Big error! "Where are the Pitcairn Islands?" "The South Pacific". "Mr, have you spoken to someone there using that tiny radio!?" "No, but I've heard amateur radio operators from there lots of times", came my grudging reply. "So how come you couldn't speak to them?" shot back my precocious little inquisitor. Oh dear, I felt brain ache coming on. I know, I shouldn't have said it, but what should have



Coffee, The Andes, and a Quad Antenna

Ray Howes G4OWY/G6AUW relates the story of the cubical quad antenna and describes how to construct your own.

been an enjoyable amateur radio jolly, had turned into an eight person interrogation. So, in a jocular way, I told them that I had an appointment with life and didn't want to miss out. As they trundled off into the distance, I gave a huge sigh of relief. I needed to get back home and knock up a large mug of my favourite psychoactive substance, a fully caffeinated Nescafé coffee. Being a bit of a tightwad, I don't own one of those fancy domestic coffee makers but I know a bloke that does, my brother. He and his partner own all the latest kitchen gizmos. You name it, they have it. In fact, they couldn't wait to demonstrate their latest kitchen gadget when I popped over for a cappuccino the other day. A Ninja Air Fryer. With a few added molecules of oil it cooks french fries quicker than you can tap out CQ, courtesy of hot air and electricity. So next time I visit, it'll be coffee and crispy french fries. Which will be tomorrow!

Another Antenna

I put up another antenna yesterday. One of those Cubical Quad type thingies. Homebrew of course. When the cash gets short (or not) it's better to build than buy. This antenna was originally conceived in Quito ('roof-top of the world', the Andean Mountains), Ecuador, during the 1940s. Its design came about as a solution to ensure that a Christian Missionary Radio Station, HCJB, could carry on broadcasting its religious transmissions to the Northern hemisphere and beyond. The Cubical Quad was the brainchild of **Clarence C Moore**

W9LZX. Station HCJB (The Voice of the Andes) had previously been using a high-Q four element beam for its transmissions. However, at 10,000 feet in thin misty air, huge corona discharges sprung forth from the tips of the antenna elements ('end effect'). Molten chunks of aluminium would drop off the antenna when it was energised. The ensuing conflagration gradually consuming the antenna!

An alternate remedy had to be found, primarily, to put an end to the ongoing firework display. A causal effect of elevation, ionisation in thin air and the four-element beam antenna not being able to withstand high voltage potentials at its tip ends. I should mention that the four-element beam being used at HCJB before it was replaced with a Quad was not your usual type beam. It was ginormous! Which was why it had lasted so long given that it was being slowly consumed bit by bit by a raging fire each time the antenna was powered up.

The original concept of the 'infamous' Quad – infamous, because not unlike some other antennas in the amateur radio lexicon, the Quad had at one point been hailed as "manna from heaven" or, by others, as a "cruel hoax". Many people in the amateur radio community were skeptical, perhaps understandably. But it was a Eureka moment, no doubt. The engineer at HCJB, W9LZX, would indeed solve what seemed to be then, an intractable problem. One solution was to place 'toilet bowl copper floats' on the tip ends of the antenna. It worked sort of. Trouble was, not only did it detune the monster antenna, corona discharges still played havoc in the

Sign up to our FREE email newsletter at www.radioenthusiast.co.uk



misty environment of Quito. The future operation of HCJB as a viable broadcasting station wholly depended upon someone waving a metaphorical magic wand. Enter the wizard, W9LZX.

The eureka moment occurred when, after much head scratching, W9LZX described a pulled-open-folded-dipole, which formed an opened loop antenna. Cube like, a shape having no ends, essentially one continuous element one wavelength in circumference, two current points one quarter wavelength apart. This Quad design was eventually constructed at the HCJB transmission site and erected in place of the existing antenna during 1942. With fingers and toes crossed, full modulated power was applied. No coronal discharge, no fireworks, no flash over. Voila! There was much celebration and many happy faces, the worrying problems with the previous antenna were now history. W9LZX also held an Ecuadorean callsign, HC1JB. Clarence went on to build a 20m Quad and hoisted it up at his QTH at Quito. The story doesn't quite end there.

Back in the USA

Because once back in America, Clarence applied for a patent for his eureka moment. As he'd discovered back in Quito, this antenna had several advantages. Lower current, thus, lower transmission loss. Similar gain to a Yagi, a lower angle of radiation, impervious to high altitudes, 'low Q', no 'end affect'

and so on. Result, the Patent Office decided after much deliberation that it be appropriate that this innovative design for a Cubical Quad (as it is cube-like when it has a parasitic element/s) antenna by its inventor, Clarence C. Moore, be issued with a patent, number 2,537,191.

Word of this innovative antenna with its high gain, its corona killing attributes, its very quiet reception capabilities, and also not being prone to rain static as are beam antennas, soon spread far and wide. Other Central American shortwave broadcasters were queuing up to have a Quad erected at their sites too. Tear down those problematic four element beams. Eager to promote the Quad antenna, Clarence built a huge rotatable Quad for a broadcasting station located at Guatemala City, Guatemala, for operation on the 49m short wave band. And Moore's superlative Quad antenna signal from HC1JB quickly got noticed by other amateur radio operators worldwide. "How do I build one?". Quads suddenly became popular. Their fame spreading like butter on hot toast (as an aside, Quads were used during the 1990s US Gulf War Desert Storm operations in Iraq).

The quad's main attraction was its relatively small size (lightweight too) when compared to a beam antenna, its power gain being comparable to a Yagi parasitic array of greater size. It can be fed with coaxial cable, open wire feeder or twin line. Cheap

to put together and easy to assemble too. For the Quad described here, four bamboo poles and a length of insulated wire. That's cheap! A lot cheaper than a fancy commercial three-element Yagi. What more could anyone possibly want? An antenna that began its life in the exotic confines of South America could be sat in your suburban back garden right now. As its fame went into overdrive during modern times, skeptics crawled out of the woodwork pouring scorn. The if's, the how's, the why's and the wherefores. "Is it really that good?" "Could it really be as effective as a tri-band beam, surely not?"

Build Your Own

Anyhow, to put a tidbit of meat on the bone technical wise, most beam antennas are either parasitic and/or driven arrays. A commercial variant of the Quad is usually both. A driven element and a parasitic element/s. To keep construction simple, basically, because A, I've got a very short attention span and B, I didn't really have the time to fiddle about constructing two Quads, one driven and one parasitic, I knocked up (literally) just a driven part, using one of those cheap and cheerful 'choc block' thingamajigs in the interim as a feedpoint connection. The plan was to insert a coaxial dipole centre piece instead, which I eventually did. But it wasn't quite finished yet.

Before a dash to the finish line, I had to secure the

Read more radio news and reviews at www.radioenthusiast.co.uk/news

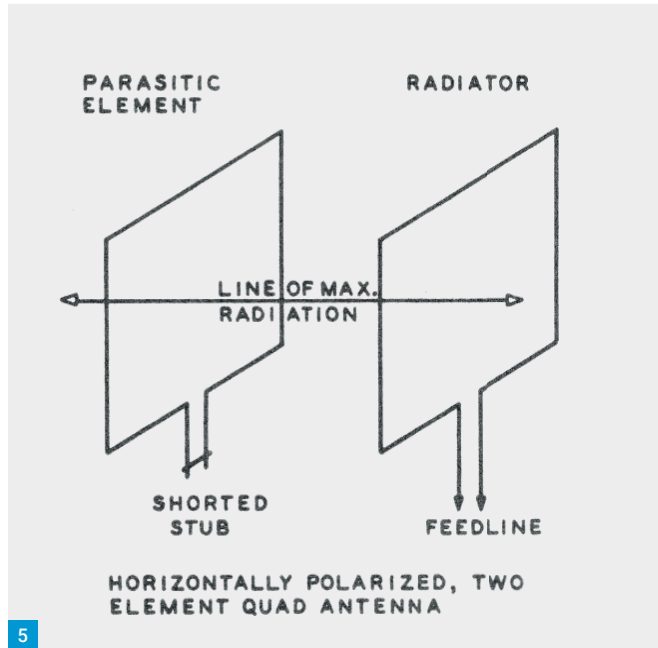

5

Fig. 1: Postage stamp featuring Andrew Young VR6AY.
 Fig. 2: Ray's completed 10m full-wave loop. Fig. 3: The feedpoint.
 Fig. 4: The editor's two-element, two-band quad under construction.
 Fig. 5: General arrangement of two-element quad.
 Fig. 6: Suggested constructional details.

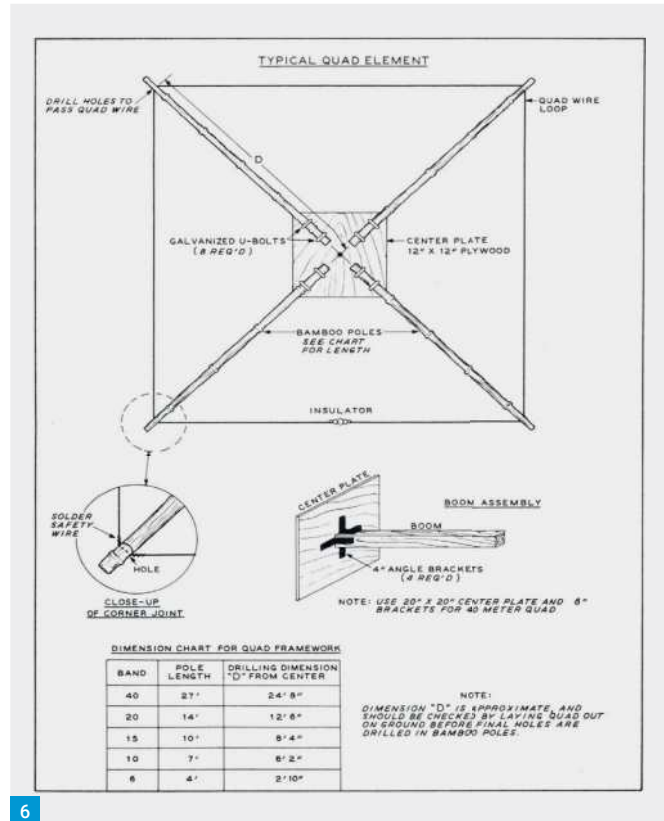

6

four bamboo poles to a centre piece of some description. I chose wood (the 'Green' brigade's word for biomass). So out came my Spear & Jackson saw to fashion it into a square shape (it doesn't have to be square. It could be round. I like to keep things symmetrical). Mine was about 12 inches square in old money. Once I'd done that, I screwed eight little brackets onto the piece of wood to attach the four lengths of bamboo. Before I did that, I'd fiddled about positioning the bamboo poles. Of course, it might be a good idea to splash some yacht varnish over the bamboo poles, including the wooden centre piece. I didn't bother faffing about doing that. When I'm not using this antenna I stick it in the summerhouse along with all the other summer time paraphernalia. Incidentally, those thin plastic poles sold in garden centres could be used instead of bamboo poles. More expensive, but no need for weatherproof protection. And maybe use a metal centre piece?

I built a 10m Quad. I thought about a 20m version, but it's too big to handle, about 18 feet each side. Each side for 10m is 8 foot nine inches (2.66m). That's big enough for the one-man-band in residence here. I used six-foot bamboo poles, which I temporarily affixed to a centre piece of wood to ensure the correct wire lengths for each side. I drilled a couple of holes in two different places in each pole end to aid tension and make sure that each of the Quad sides are as prescribed. You don't want floppy-flappy wire. It's just wood, bamboo and wire. No calculus needed. See the photos, **Figs. 2 and 3**. Here comes the fiddly part. Well, you didn't really

think it was all going to be plain sailing did you? The radiation resistance of this sky-wire is approximately 120Ω, so you'll need a transformer. Transform something. For example, flour, water, sugar, butter and yeast into brioche. But in this case, from 120Ω to 50Ω. You'll need some 70Ω coaxial cable. I used 75Ω coax (keep that under your hat). Five foot eleven inches long, about 1.8m. This will eventually be connected to your expensive transceiver, or not, to a 50Ω ohm transmission line via the coaxial matching transformer.

You now have a choice. Either make sweet little piggy-tails at both ends of the 70/75Ω transformer cable and one end of the 50Ω feedline, which is easy peasy. Or as I did, put PL259s on all the connections. Neater. If you decide to go the piggy-tail route, I'm sure I won't need to describe the intricate details here. Except to mention that if you decide to leave your handiwork permanently parked outside (where it will make a convenient perch for the local bird life), all the coaxial ends will have to be liberally wrapped in waterproof insulation tape. Again, you might want to slosh some yacht varnish on the bamboo poles too. If you've bought those thin plastic poles that gardeners use to prop up runner beans and raspberries, ditch the yacht varnish. Luckily, on my first outing with the 10m Quad (10W SSB), radio-sport was rife. Signals romped in. Among others, I worked the Canary Islands, France, Spain, IK5SRF (in Italy of course, unless he was pretending). And HB9HLM. I heard a VE and a VU station but couldn't penetrate the ever expanding wall of excitement. Not even with a squirt of CW.

Clarence C Moore founded the International Radio & Electronic Corporation established in 1947, subsequently renamed Crown International at the behest of his wife. And at one time Moore owned two commercial domestic radio stations, WXAX and WCMR. Clarence died in 1979, sadly, a couple of years before the completion of a 500kW transmitter he'd helped to develop for station HCJB. The original Quito transmitter site was torn down to make way for an airport and relocated. HCJB now broadcasts (a mere shadow of its former self) short wave transmissions from Mt Pichincha near Quito.

Editor's note: What Ray ended up building, of course, was a full-wave loop (see GM6DX's article in this issue), presumably with the hope of adding a parasitic element later. But his article reminds me that I built two cubical quad antennas along these lines, the first around 1977, a two-element 10m version with garden canes that must have cost me all of about £2.50. It was my first 'gain' antenna and, at the top of the sunspot cycle, gave me worldwide DX. The next, built a few years later, was a two-band version for 10 and 12m, which again worked well at minimal cost. The photo, **Fig. 4**, shows how I attached the spreaders and boom. **Figs. 5 and 6**, taken from *All About Cubical Quad Antennas*, by the late **William Orr W6SAI**, show the principle and the constructional method he recommended. It's worth mentioning, too, that adding the parasitic element (usually a reflector) brings the feedpoint impedance down to something approaching 50Ω so it can be fed directly with your usual coaxial cable. **PW**

Don Field G3XTT

practicalwireless@warnersgroup.co.uk

I well remember the Geochron as a large, expensive, mechanical moving map display showing time and a world map with the terminator (daylight/darkness boundary) moving across it in real-time. Apparently some 30,000 were made over the years (it was first introduced in 1964) and used in prestigious locations such as the White House, as well as featuring in films such as *The Hunt for Red October*. Indeed, you can still, it seems, buy a refurbished one if you have the funds!

The Modern Geochron

Move on to the present day and, unsurprisingly, computer technology has caught up with the Geochron. What you now get (the Geochron Digital 4K Atlas 2) is a module with an inbuilt Linux processor (I must admit, I had been expecting some software to run on my PC but, no, it's a stand-alone unit), that hangs on an HDMI lead on the back of a monitor or TV. You are recommended to use a 4K display for best resolution although it will support 720i displays upwards. On show at the Newark Hamfest on the Purple Zebra stand (they also, incidentally, do a nice range in illuminated callsign displays for the shack), it generated a lot of interest.

What arrives are the items shown in the photo, **Fig. 1**. The main unit, a short HDMI lead, remote control, PSU and a USB dongle (presumably Bluetooth) to communicate with the remote control. There is also a Quick Start guide.

Setting it up is simple enough – plug it in, connect to your home WiFi or Ethernet and wait while it downloads all the latest software and data. Then you are ready to go.

Features

Obviously, in the computer age, the Geochron can do very much more than its mechanical predecessors. For example, out of the box it can show weather information, satellite, Hubble space telescope and ISS tracking (you can select which satellites you want to track), live commercial flights (you can select which airlines or continents you are interested in), undersea cables and even the latest COVID-19 data (I decided to pass on that!). You can also add labelled 'pins' to the display, for example, to show your own location.

But what radio amateurs will be interested in is the Ham Radio Bundle, available as a so-called Premium Layer (and priced at \$6.99 a month or \$69 per year subscription). This offers: Personal ADIF log, Live DX spotting, Custom call-sign, Maximum usable frequency, AMSAT satellites, Maidenhead Grid, Solar-terrestrial weather

Any or all of the above can be displayed at any one time (as indeed, can any of the previously mentioned facilities). Of course, this can make the screen rather 'busy' as illustrated in **Fig. 2**. So, the trick is to decide which you are most interested



1

The Geochron

Don G3XTT takes a look at a smart and handy addition to the shack.

in or, alternatively, you can ask the unit to scroll through various screen selections at a pre-defined interval.

Selecting what you want to display is simple enough, **Fig. 3**, in this case setting up what DX spots you want to see. Those in green are selected and will display. I also find it useful to have the latest solar data displayed, along with propagation data that is refreshed from the DX Cluster and/or Reverse Beacon networks. You can choose which band(s) to display and how old the data is. The display also shows the position of the sun and the position and phase of the moon. **Fig. 4** is the screen set up to show Maximum Usable Frequency (MUF) data – very handy.

Obviously, as you'd expect nowadays, there are plenty of options for adjusting the display, while the map on which all this is shown is a standard Mercator projection and, yes, still shows date, time and the terminator, along with the various world time zones.

As well as the Ham Radio Bundle, other current premium layers (i.e. at additional cost) are the Earthquake Layer, the Premium Atmospheric Layer and (a nice one this) the ISS Live Earth View, which shows in a window within the main screen. I feel sure further premium layers will be added as time goes on. And, indeed, there are improvements in



2



3

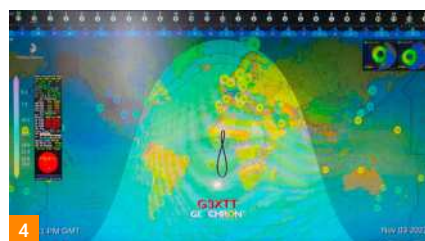

4

the pipeline for the Ham Radio Bundle, initially by way of FT8 and WSPR spotting.

There is a Help menu available in Geochron, with a number of videos, including one explaining how to set up the various features in the Ham Radio Bundle. There is also plenty of information, again including videos, on the Geochron website (below). More on the history of the original Geochron, the facilities and use of the electronic version and subscriptions for the premium layers can also be found on the website.

www.geochron.com
<https://geochron.co.uk>

Interestingly, the Geochron unit has a USB interface, a MicroSD slot and a headphone socket, none of which is actually used at the moment. There is, though, an RJ45 connector for wired internet, for those unable to use WiFi.

The Geochron sells from £399 and is available from Purple Zebra (website below), who kindly loaned the review model.

<https://purple-zebra.com>

Fig. 1: What's in the box.

Fig. 2: The screen can easily become rather busy!

Fig. 3: Setup screen for selecting DX information.

Fig. 4: The MUF display, also showing solar data and the aurora forecast.

Sign up to our FREE email newsletter at www.radioenthusiast.co.uk

RSGB BOOKSHOP

Always the best Amateur Radio books and more



New Titles

Computers in Amateur Radio (3rd Edition)

Edited by Lorna Smart, 2E0POI

Amateur radio is a fast-moving technological world, with much done in conjunction with the equally fast-moving world of computers. Amateur radio interacts far beyond traditional personal computers with much use made of Raspberry Pi computers, mobile phones and other technologies

Computers in Amateur Radio is a must-have companion book for both those who are new to the hobby and the more experienced user. It works well both as a manual and a reference guide with its many illustrated step-by-step guides and reference information.

174x240mm, 192pages, ISBN: 9781 9139 9528 7, **Non Members: £15.99**

Also available
amazon
kindle

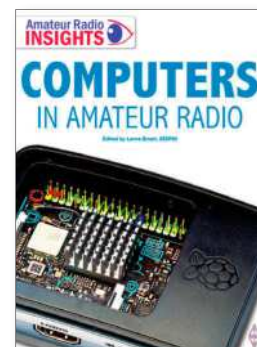

Using GPS in Amateur Radio

By Andrew Barron, ZL3DW

Today many of us have GPS (Global Positioning Satellites) units in our cars, a host of other gadgets and even some amateur radio equipment. However, as radio amateurs are we getting the most from this technology? Andrew Barron, ZL3DW sets out to explain the GPS technology and illustrates how you can experiment with it.

Using GPS in Amateur Radio is about GPS and other GNSS (Global Navigation Satellite System) satellites and how we can use the data broadcast by them for amateur radio. As always, Andrew has written a practical book in an easy to understand way that provides what you need to know in a digestible format.

174 x 240mm, 176 pages, ISBN: 9781 9139 9527 0, **Non Members: £14.99**

Also available
amazon
kindle

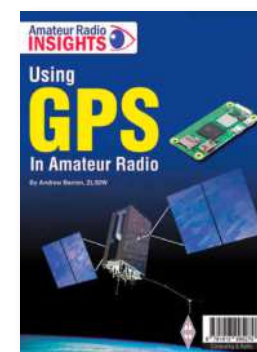

RSGB Yearbook 2023

By Mike Brown, G3DIH

A massive 608 pages with nearly 100,000 callsign listings, and over 1.4 million words. It remains the most comprehensive guide to amateur radio in the UK and worldwide.

With nearly 100,000 amateur radio licences on issue, this is the very latest listing available. Far more than just a list of callsigns, you will also find the latest information on every aspect of the RSGB, from how the Society is organised, the services it offers, committees, who to contact for assistance, etc. This remains the one source of current UK callsign data that is up to date and comprehensive.

210x297mm, 608 pages, ISBN: 9781 9139 9523 2, **Non Members: £22.99**



HF DX Basics

By Steve Telenius-Lowe, PJ4DX

One thing that is certain is that when propagation improves, contacting far flung parts of the world (DX) on the High Frequency bands (HF) becomes easier and much more of a pleasure. It remains one of the enduring fascinations of amateur radio.

HF DX Basics provides a practical guide to making the most of this endlessly fascinating area of operation. Many are put off by the challenges of DX operation but well-known author and DXer Steve Telenius-Lowe, PJ4DX dispels the myths about huge antennas and high power in an easy-to-understand way.

174 x 240mm, 144 pages, ISBN: 9781 9139 9522 5, **Non Members: £11.99**

Also available
amazon
kindle

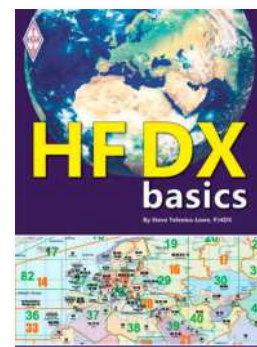

E&OE (All prices displayed plus p&p)

www.rsgbshop.org

Radio Society of Great Britain 3 Abbey Court, Priory Business Park, Bedford, MK44 3WH Tel: 01234 832700

Tim Kirby GW4VXE
gw4vxe@icloud.com

Activity levels at VHF/UHF frequently come up in discussions. I recently had a letter from a reader who wished to remain anonymous, but had recently returned to the hobby, having first been licensed in the 1980s and, of course, had seen some changes. He asked me whether it was worth getting some antennas up for the VHF/UHF bands. Of course, I said yes, but I hope you might find my reply interesting.

I'm not sure I have a great reply for you. I think there are all sorts of factors at play here.

You and I were both licensed around the same time so remember the days of a busy 2m band on both SSB and FM. The world has changed! SSB is busy during the monthly UK Activity Contests and perhaps during a tropo opening (though I wouldn't bet on it). As you can see from the PW list of VHF/UHF nets (URL below) there are plenty of local nets on FM (and a few on SSB) but simplex activity generally is fairly low and repeater activity can be similar outside of commute times.

<https://tinyurl.com/2ma53dyy>

I would suggest that many amateurs are now less likely to want to have a long chat, remembering that there are generations of people now who prefer to send a text message rather than make a phone call (I include myself in this!). Data communications suit them. Even on CW or SSB, quick fire QSOs are far more common now than they were 30 or 40 years ago.

For some people with small houses and young families, SSB or FM operation is nothing less than antisocial to the rest of the family who may be trying to sleep or rest. That was a reason I always preferred CW!

With the change in licensing, it's quite possible that many will go to HF to have their chats. Tuning across 40m SSB during the daytime reveals many Foundation and Intermediate calls making QSOs. In days gone by, they would have been on 2m.

Activity generally is now so much more diverse than in the 1980s, across different bands and modes. This is good in many ways, because it means that there are lots of different and interesting things going on, some of them quite ground breaking too (look at the low bandwidth Digital TV experiments that have been going on in recent years, as an example).

So, actually, I'm rather more optimistic. I think there is plenty going on at VHF/UHF. FT8 operation on 2m and 6m goes on every day and on 2m, recent activity levels on FT8 probably showed more QSOs being made each day than at any point since the 1980s. Digital communications mean that modes considered specialist in the past such as meteor scatter or

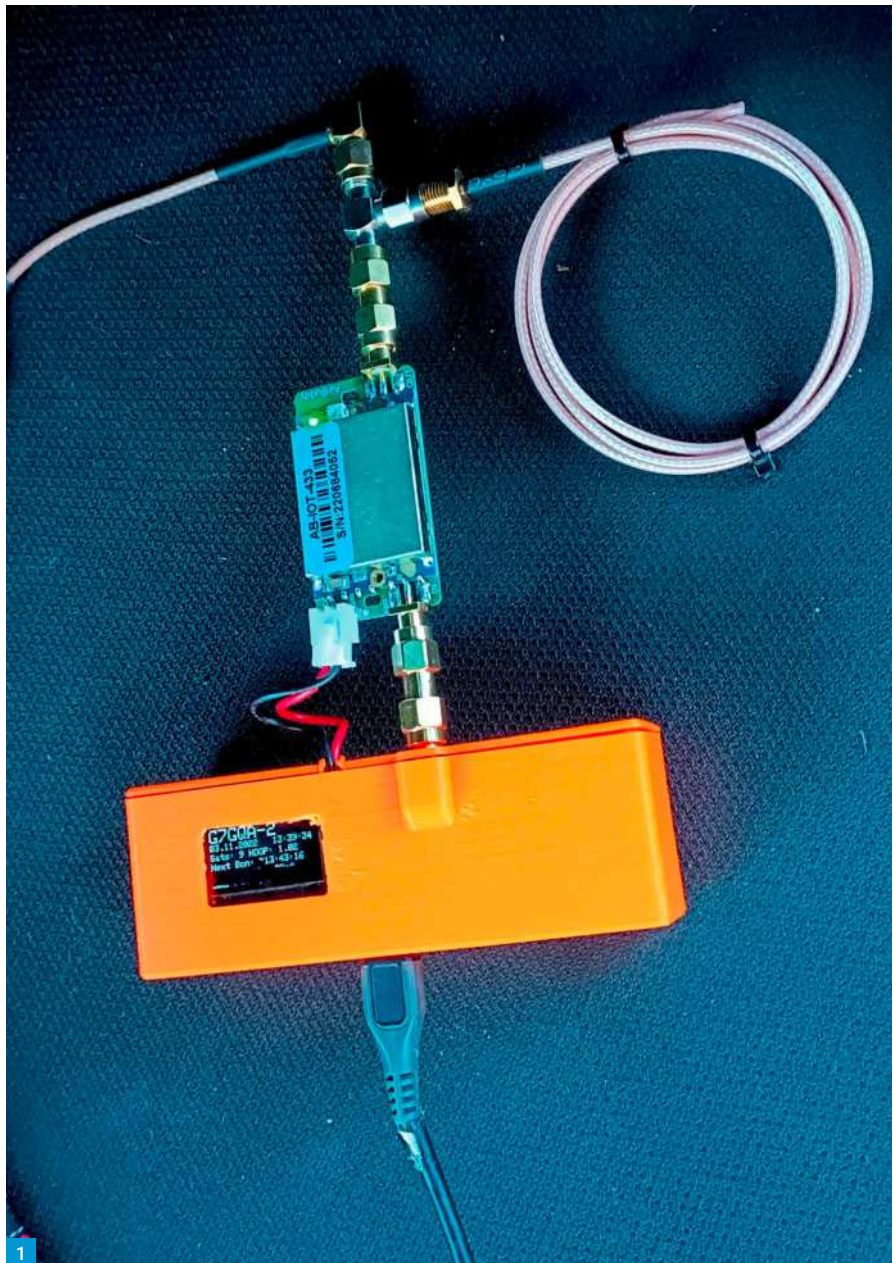

VHF/UHF Activity

Tim Kirby GW4VXE starts this month with a discussion related to the recurring concern about VHF/UHF activity.

moonbounce are achievable by people with an average station. Digital voice modes, particularly on 70cm, show a great deal of innovation and provide interest for those interested in integrating radio communication with an interest in computing.

It's unfortunate when people say, 'I'm not interested in digital comms' and then go on to complain about a lack of activity on the modes they like. It's a bit like when the SSB to AM migration happened, those left on AM wondered

where all the activity had gone (I found some quite bitter correspondence about this!). But, we're all entitled to our own views and choices about the modes and bands that we use.

*I think there is plenty going on, but it's just not obvious to the casual listener. I can understand why people may tune across the band and be disappointed. This was one of the reasons that I started to publish the list of VHF/UHF nets in PW, to give people something to listen to. **John G4SWX**, the RSGB's VHF Manager recognised*

Sign up to our FREE email newsletter at www.radioenthusiast.co.uk

Fig 1: G7GQA's APRS Lora Tracker.

Fig. 2: Patrick WD9EWK waiting for AO-27 to peep above the horizon for his sked with VE1CWJ/VP9. Fig. 3: John VE1CWJ/VP9 operating from the beach in Bermuda.

this issue too, some months ago, and made some tentative proposals towards a beginner's licence, at a much more basic level than the Foundation, such that people could very simply achieve a licence that would give them something like 10W out on 2m and 70cm and get them chatting. I am not sure whether anything came of this idea, but it could be well worth a try.

In general, though, I think there is a move from a 'chatty style' of contact to a quicker exchange. I can only conclude that this is what most people want to do, so there is little point in worrying about it and wishing that it were otherwise.

In conclusion, I'm not sure that this will be much comfort to you but I would encourage you to get on the VHF bands in whatever way you enjoy, perhaps set up some local activity periods with friends. You may well be surprised and find other people joining you. I hope so!

On an associated theme, **Ian Dilworth G3WRT**, wrote to the editor about decreasing activity levels on repeaters. One of the reasons that Ian cited was the growing number of voice IDs used on repeaters (as opposed to CW identification). Ian finds these more annoying when doing something else in the shack and therefore switches off, so will not be listening when someone else calls through the repeater – meaning perhaps, that their call goes unanswered.

Although it's not something I'd noticed myself, I'm not a huge fan of voice IDs on repeaters. For me, knowing Morse, it's far easier for me to read a noisy CW ident of a distant repeater than a noisy voice identifier – particularly if it is not in my native language. Having said all that, voice IDs are probably more inclusive than CW IDs. Maybe a hybrid, Voice followed by a CW ID of just the callsign at 30wpm or more, might be best of all!

One solution, employed by some repeater keepers, I believe, is that the repeater does not transmit a CTCSS tone while sending the voice ID, so that if you are monitoring using CTCSS squelch, you will not hear the voice. This seems a good solution.

Ian raises the good point that potentially, a band that sounds empty, may put our spectrum at threat. So, a bit of 'obvious' FM or SSB activity from all of us from time to time, can only be a good thing.

Simon's World Map

Who is Simon? He's **Simon Brown G4ELI**, well known author of the excellent SDR Console software. Simon has written another nice piece



of software which makes a useful display in your shack, capable of running on Windows computers.

It's a World Map, but you can overlay all sorts of information on it; Auroral data, Solar Data, Satellite tracks, locations of stations, Sunrise/Sunset/Greyline. There's even the ability to control certain rotators.

The program is still actively being developed and Simon tells me there are plenty more features to come, which is exciting. You can read more about Simon's World Map, and download it for free, from:

www.g4eli.com/world-map

GB3MCB Beacons

Peter Taylor G8BCG says that the new GB3MCB/B beacons on 28.215, 40.050 and 60.300MHz are getting spotted regularly and providing good indicators for what the MUF is doing. You can see the spots and Peter asks for you to make your own here:

www.dxsummit.fi/#/?dx_calls=GB3MCB

The 8m Band

Roger Laphorn G3XBM (Cambridge) was delighted that his low power FT8 signal from his FT-817ND and low wire dipole made it to the USA on 4 November, being heard by two stations, with N2OTO (EL96) being the furthest at 7094km. Roger also received WM2XEJ on 8m that day. He says, "the sooner we all get a small 8m amateur allocation, the better!". On 12 November, Roger heard ZS6WAB very strongly on 8m FT8 over a distance of 8931km.

Peter Taylor G8BCG (Liskeard) writes, "Regular spots of the 5W GB3MCB/B on 8m from

North America have certainly prompted some activity. I've now worked S50B, S59F, ON5QRP, SP5NOF, S57A, 9A5CW, ZS6WAB, EI3KD, ZS60B, WM2XEJ and EI4GNB. It's not easy with my 5W to a wire dipole but sometimes that's all you need!"

The 6m Band

Don G3XTT (Wells) caught the TEP opening to South America on the evening of 16 October, working a number of Brazilian stations. Don also heard ZD7BG, although did not work him, having made a QSO with St Helena earlier in the year. Don found a new one on the band by way of 5V7RU, working them on 4 November, closely followed by EL2BG and J28MD with some more PY stations in the evening, for good measure! Don says he is enjoying the TEP and has also copied CX6VM, 9G, TT and D4L to name but a few. Don later worked TR8CA and ZS6NK on 10 November.

Kevin Hewitt ZB2GI (Gibraltar) operated from the Gibraltar Club station and lists some nice QSOs made (mostly) via TEP: CE2SV (FF47), CT1FFU (IM59), EA7AH (IM67), EC4C (IM68), LU5FF (FF99), PJ4MM (FK52), PU2MBY (GG47), PY1LC (GG87), PY1MHZ (GG98), PY2EDY (GG66), PY2MC (GG67), PY2RC (GG67), PY4AQ (GG88), PY5HOT (GG46), PY5KD (GG54) and ZD7BG (IH74). PJ4MM won't have been TEP as both stations are north of the equator, of course and EC4C will probably have been backscatter.

Steve Telenius-Lowe PJ4DX says that "it was another interesting month on 6m. I worked a few Europeans using FT8 on 16 October, including **Neil G0JHC**, the only UK station contacted on

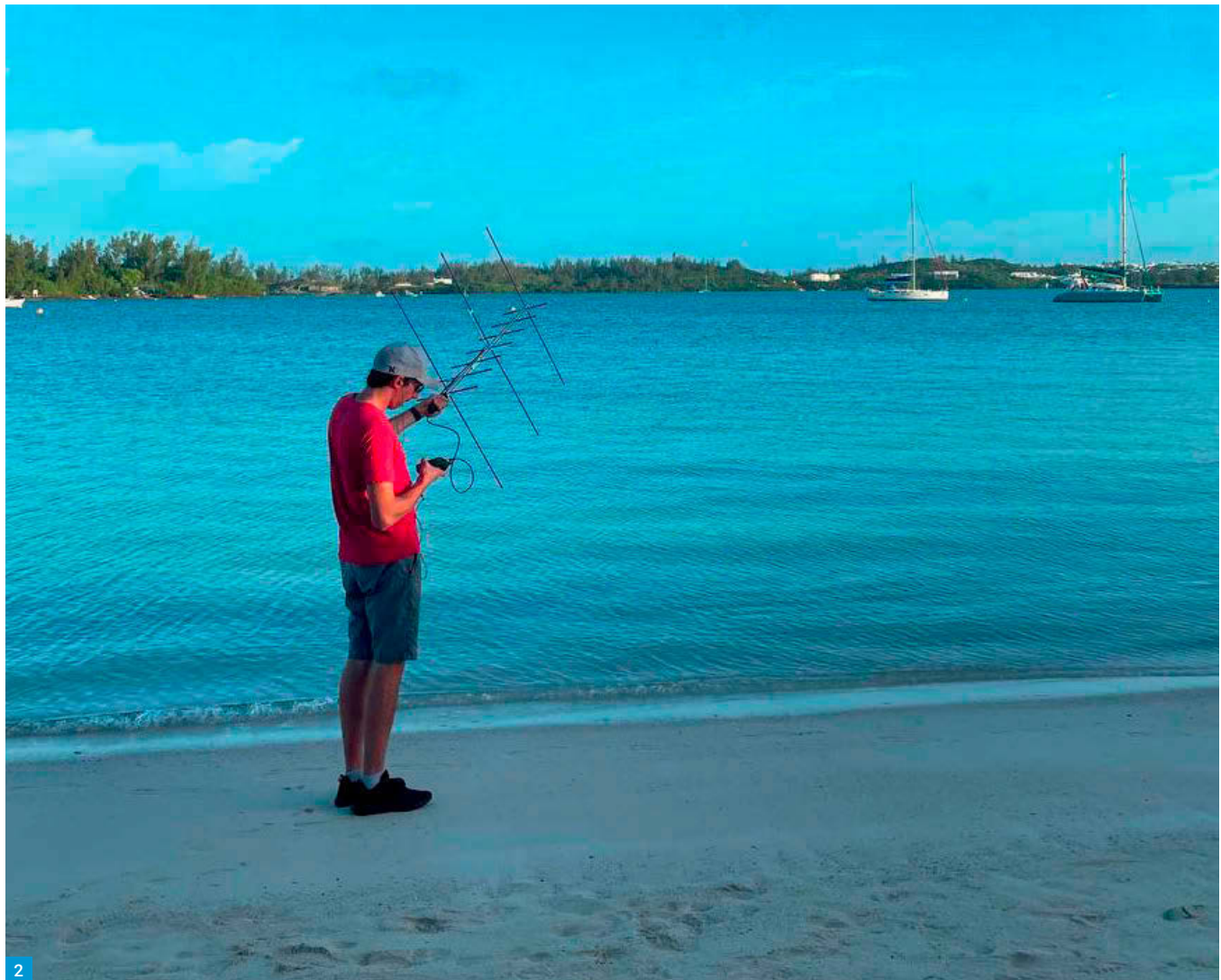

2

Six since the end of the Sporadic E season. The following day C6ACB was a good one among other Caribbean and USA stations contacted. The band really opened up between 22 and 25 October", Steve says, "best DX being FO5QB, FY5HB, V26OC, TY0RU, YB1TJ and 9J2BS. On 30 October PZ1EW was a new one while on 1 November CX, FY, LU and PY were all worked on SSB. I was also called by CX5FF who was using AM!" Also in early November were D4L, CE6TK (on SSB) and, "on the 8th, my best DX of the month: CE0YHO on Easter Island, giving me five new DXCC entities on Six this month. On 10 November I worked HZ1SK at 1532, while on the 11th there was another long-path opening to Indonesia between 1545 and 1645UTC. In that hour I could only decode, and work, four stations: YC0COU, YB1TJ (again!), YB0SAS and YB2DX".

Peter G8BCG writes, "In previous cycles with CW and SSB, I often needed a bit of tropo or Es extension to get into the 6m TEP bubble – but with FT8 it's looking like the southern UK at least will be 'in the zone' this cycle. Already we are noticing some amazing (and repeated)

paths to South Africa and South America. On 5 November PSK Reporter was pretty quiet but I had a 'feeling'. I decided to go up the hill and just check. On a silent band there was 7Q6M calling CQ at -15. I spotted and called him, he turned his beam from S America, came up to -3 and we had an easy QSO! Pure TEP. In for about 25mins with nothing else on the band".

Keith Nolan EI5IN (County Westmeath) says that he and Brian EI8IU from the Shannon Basin Radio Club were operating during the early evenings on 16 to 18 October, mostly looking for Sporadic E. However, Brian had some very nice TEP QSOs with TT8SN, 3B8FA and V51WW, all on FT8.

Here at GW4VXE (Goodwick) I caught some Es to Spain on 16 October, but then the opening extended to PY and ZD7, with a good number of Brazilian stations making it into the log. There were more PYs the following day.

I did manage to copy the TY0RU expedition, but not sufficiently to think about calling, let alone make a QSO. On 4 November, I worked PY1MHZ (GG98) with a couple of other

Brazilians being heard, but the highlight on 7 November was working 5V7RU (JJ06).

The 4m Band

Roger G3XBM says he has dug out his old transverter for the 4m band, and despite having no antenna for the band (he used his 8m one instead), he has heard several stations on FT8, including one European station via Es.

The 2m Band

Ian Bontoft G4ELW (Bridgwater) just missed the last deadline having attended the Hamfest at Newark. He enjoyed the tropo at the start of the October. On 3 October he worked F8BON (IN86) and EA2XR (IN83). Next day he worked F5LMG (IN88), EC2BBS (IN93), EA1NL (IN52), EA1U (IN83), EA1HRR (IN83) and EA1UR (IN53). Ian says that EA1U came up to +13 at one point during the afternoon. Propagation was starting to move east from Ian the next day, but he still worked EA2BBS (IN93). In early November, Ian worked EA2XR (IN83) and on 11 November, he was pleased to work DF6WE (JO31), ON4IPR

Sign up to our FREE email newsletter at www.radioenthusiast.co.uk

(JO10) and DF5VAE (JO64). Ian runs 15W of FT8 to a 5-element Yagi at 4m above the ground. By all accounts, this tropo event was quite interesting. **Paul Pasquet G4RRA** (Okehampton) managed to work UA2FBW as well as a number of SP stations.

David Johnson G4DHF (Spalding) wrote about the tropo opening on 19 October, "Given the general uncertain nature of the recent wx, I was pleasantly surprised by the high-level ducting that occurred late yesterday afternoon. Stations at altitude in IO93 and 94 had the better, I believe, but given my sea-level QTH, I was pleased to work over 50 EU stations on FT8, including HA6KVC (JN97), SP9EMF (JN99), SP6CVB (JO80), SP9HE (JO90), SP6LTM (JO80), SP6SYU (JO71), SP3NYF (JO72), SQ1FYB (JO73), OK2BRD (JN99), OK2WO (JN89), OK1ADT (JO80), OK1DXR (JO60), OK1DOY (JO60) and OK1TEH (JO70) on SSB.

"There was a pronounced duct into EU, but I also worked a number of OZs on the same beam heading of around 100°. Even more surprising, I was called by and worked SK6IF (JO58), SM7WW (JO65) and LA3QAA (JO59) on the same heading".

Jef VanRaepenbusch ON8NT (Aalter) worked G4EII (IO83) on FT8 on 5 October during the tropo opening.

Simon Evans G6AHX (Twynning) took part in the RSGB UK Activity Contest on 1 November, but says that conditions were dreadful with strong winds and rain restricting the number of portable stations that were active. Simon's best DX was F1BHL/P on the Cherbourg peninsula.

Robert Van der Zaal PA9RZ (Sassenheim) experienced some problems with his IC-9700 recently, with it generating no power on SSB, yet full power on FM and CW. Despite a number of Full Resets, things weren't right. The problem ended up being a fault in the microphone that Robert was using. During the Marconi CW contest, Robert used his IC-705 and made a few QSOs with 5W to his 5-element Yagi; F6DWG/P (JN19), G3XDY (JO22) and G5RS/P (JO00).

Andy Adams GWOKZG (Letterston) reports hearing some Scottish stations via Aurora, on CW on the evening of 7 November.

Roger Greengrass EI8KN (Co Waterford) says he doesn't have much to report this month, but during the second leg of the ARRL EME Contest on 12 November Roger worked PA5Y 'off the moon'. Roger uses a 12-element Yagi and no preamp.

The 70cm Band

Kev ZB2GI has been working a few more stations on cruise ships around the Mediterranean, using the ZB2BU/R 70cm repeater, including GOLFF/MM on the *Marella Discovery*, M0MNE/MM on an LNG tanker, *British Contributor*, some 70 nautical miles east

of Gibraltar and N2GG/MM on the *Celebrity Edge*.

Andy Doswell G7GQA (Cheltenham) and **Jayne M0JNE** have been playing with APRS Lora on the band, **Fig. 1**. This uses very low power devices, around 100mW. Andy writes, "With 100mW TX power on a tracker in the car, I can achieve about 10 miles. The iGate at home is just sat in the window of an upstairs room in my house, with a small stubby antenna, and is only getting about a mile. I've got an old ex-army collinear, which I may put up at the weekend if the WX improves". Andy continues, "There's more info here:

<https://tinyurl.com/5n95rt95>

"You do need to change the frequency from the default. As those users with digipeating enabled and, therefore an NoV being required, are issued the frequency 439.9125, so that's the frequency we plumped for".

This looks very interesting. I wonder if any other readers are experimenting with APRS LORA?

Jef ON8NT worked GW4HDF (IO81) on FT8 during the tropo in early October.

Both Simon G6AHX and **John Hawes G8CQX** (Cheltenham) report that a new 70cm repeater is active from the Cotswold escarpment near Cheltenham. **GB3RC** seems to be giving good coverage and is quite similar to the old GB3UK repeater, which occupied a nearby site.

The 23cm Band and Above

Jef ON8NT worked G3XDY (JO02) and G40DA (IO92) on 23cm CW on 18 October. On SSB, Jef worked G4FEV (IO92), and G4CLA (IO92) – at 355km, this is Jef's best DX on the band so far. On 19 October, during the FT8 Activity session, Jef worked G7LRQ (IO91) and G0JJG (JO02). Jef runs 10W from an Icom IC-9700 to a WIMO flat panel antenna.

Roger G3XBM says that his 23cm transverter has arrived and he hopes to start local tests soon. His plan is to try some UK Activity Contests portable next year.

Steve Macdonald G4AQB (Bolton) writes, "On 23cm, our net on 1297.500MHz FM is still going strong with a number of new stations calling in. Although most stations are in the Manchester area, anyone is welcome to join in, nearly all stations are using horizontal polarisation so, try pointing your beam to IO83 square on Wednesday evenings at 8.30pm and have a listen!

"Moving on to the higher bands, some stations near to me are having problems with noise from local mobile network transmitters, particularly on 13cm and with one station on 9cm when out portable on Winter Hill during the UKAC SHF Contests. They are currently testing and evaluating some interdigital filters for these bands to reduce the noise during contests. I

have a similar problem with noise on 13cm on one particular beam heading, so I am looking forward to the results of the interdigital filter tests. As more and more 5G transmitters and masts are appearing, noise on the higher bands is likely to be a problem in the future".

Satellites

Jef ON8NT continues his FT4 activity on satellites and this month has EB4ADC (IN80), CT1ETE (IN51), EA3TA (JN11) and ON2ACO (JO11) in the log.

Patrick Stoddard WD9EWK (Phoenix) writes, "In October, **John VE1CWJ** announced his plans for a weekend in Bermuda, with satellite operating as part of his travel plans. John and I exchanged messages and started looking at some passes that would work. John arrived in Bermuda on Thursday 10 November. There was an AO-27 pass on Friday 11 November that covered both of us, and I asked John if he could try a pass around 1418 UTC (7.18am local time in Arizona, 11.18am local time in Bermuda). John said he would give that a try.

"I could have worked the AO-27 pass from home, but I would have a better view of the north-eastern sky from a Phoenix city park – a park that is on the DM33/DM43 grid boundary. I went to the park and set up for the pass as the sun appeared in the eastern sky. This pass wasn't high on either end, with about 7° elevation for VE1CWJ/VP9 as AO-27 rose above the horizon. I was able to hear the AO-27 downlink switch on, 30 to 45 seconds after AOS, and then had to wait a little longer for the voices on the downlink to be clear enough to make a QSO, **Fig. 2**.

"Once I started hearing the downlink clearly, I waited for a clear spot to make my call. I called for John, and he immediately answered me with his grid locator FM72. We made our contact, and then VE1CWJ/VP9 worked a couple of other stations before the AO-27 downlink switched off. This was a great start to a long weekend. Even better... John uploaded our QSO to Logbook of the World about 45 minutes after we made our contact. Impressive! Our AO-27 contact was a new grid and new DXCC entity for my satellite log".

I too was thrilled to work VE1CWJ/VP9, **Fig. 3**, on RS-44 here at GW4VXE, particularly as I thought I'd missed my opportunity to do so as a result of an all-day Welsh class! It was a good month on the satellites here, with a number of interesting QSOs; 4J6D (LN05) on AO-27, FG80J (FK96) on RS-44 as well as VA7LM (CO54) on RS-44. Bermuda made my 50th DXCC on LEO satellites. It might get harder from now!

Thanks to everyone who has been in touch with their news and for your support of the column throughout the year. May I wish you and your families a very Merry Christmas and all the best for 2023. **PW**

Nils Schiffhauer DK8OK
dk8ok@gmx.net

The Global Maritime Distress and Safety System, or GMDSS, is a system of different maritime communications tools on frequencies ranging from as low as 424kHz [NAVTEX] over HF and VHF up to satellite channels in the GHz region. This article focuses on the Black Cat GMDSS decoder (link to free test version below), hence on HF. There, the six main channels (there are some more with only minuscule traffic) range from 2MHz to 16MHz. Reception of both, Coastal Stations and vessels, is from around the world. In this case from Vestmannaeyjar Radio in Iceland to Cape Town Radio in South Africa, and from Valparaiso Playo Ancha Radio in Chile to Taupo Maritime Radio in New Zealand. You may hear vessels of each kind, from small ones for pleasure to the biggest oil tankers, and from all over the world. Monitoring on all six main channels in parallel, often raises 3,500+ messages a day!

<https://tinyurl.com/y8ajtpk>

Where a Good SDR shines

All you need is a good SDR, covering at least 15MHz bandwidth to cover all channels, alias-free. Plus, preferably, an active antenna with good performance over this challenging wide range, spanning from 2187.5kHz to 16804.5kHz. You also need software, providing at least six demodulator outputs and a virtual audio cable software with at least six channels to connect the SDR with the decoder, Fig. 1. You don't already have all that at hand? Then it's high time to leaf through catalogues and lay an even more solid base to your hobby! But wait a minute, as you can at least start with GMDSS right now with existing equipment. Possibly on just a limited number of channels, but even this will raise results galore.

I am using an Elad FDM-S3 and a Winradio Sigma together with an active vertical dipole MD-300DX (2 x 5m), plus SDRC and VAC software (see links below). Also, I saved all six main GMDSS channels as 'Favourites' in SDRC software under a folder called 'GMDSS'. So, I have all channels ready to set sail with just a mouse click.

<https://tinyurl.com/arvauv5v>

www.winradio.com/home/g65ddce.htm

<https://tinyurl.com/y8bvzjvm>

www.sdr-radio.co

<https://vac.muzychenko.net/en>

Robust Waveform, Clever Coding

GMDSS' signal is of 2-FSK with 170Hz shift at a speed of 100Bd. Its waveform is 'kind of' SITOR-B, repeating each character twice with a 400ms spread to enhance proper decoding under adverse propagation, as laid down in ITU's

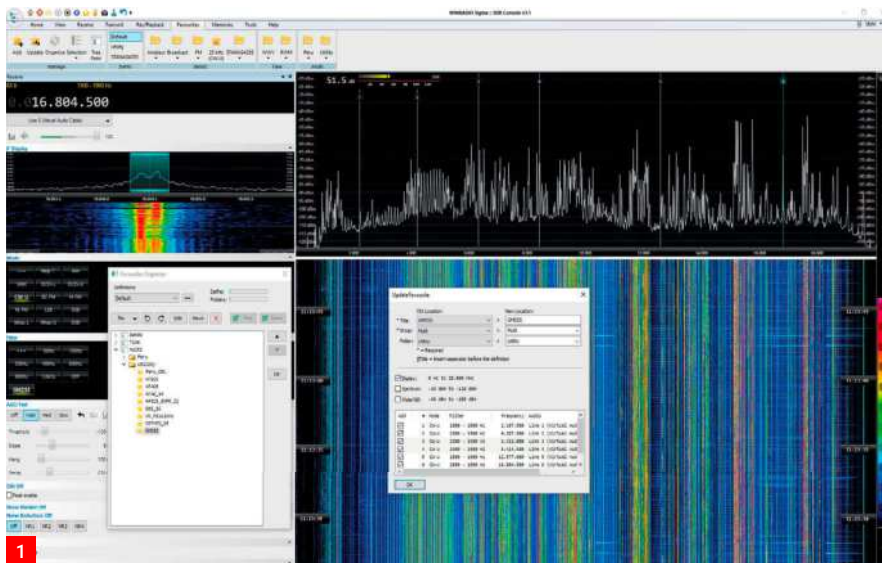

Ahoy! BCS-GMDSS Decodes Eight Channels in a Row

Interested in receiving 3,500+ messages per day on HF on just six HF channels, plus smart features to control this ocean of logs? Then you must try Black Cat Systems' multi-channel GMDSS decoder! **Nils Schiffhauer DK8OK** is excited about performance and data handling.

Recommendation ITU-R M.493-11:

<https://tinyurl.com/39j4nmt9>

To establish a call, each station has been assigned a unique MMSI, or Maritime Mobile Security Identity number consisting of now nine digits, in future ten digits. MMSIs starting with 00 denote a Coastal Station, eg 004123100 for Guangzhou Radio/China. There is a set of 127 symbols, with the first numbers 00 to 99 representing numbers, and each of the remaining number specific situations such as '110' denoting 'Man overboard'. The software looks up those source-coded messages in a *codebook* to print a readable message, giving some sense.

One message is about 6.4 seconds long. It starts with a short dot-pattern/phasing sequence for automatic tuning, followed by the content. In this live example, JRCC Australia

(MMSI 003669991) is calling Merchant Oil tanker *Signal Maya* (MMSI 248410000) on 12577kHz at 15:59:43 UTC on November 21, 2021. There are transmitted 23 groups ('Symbols') in GMDSS:

```
120 120 021 007 061 000 000 108 000 050 030
000 010 118 126 126 126 126 126 126 122
111
```

Which are decoded as follows:

120 120 -> Format

021 007 061 000 000 -> Address – MMSI of called station

108 -> Category

000 050 030 000 010 -> Self MMSI – MMSI of calling station

118 126 -> first and second [none in this case, 'idling'] telecommand message

126 126 126 -> frequency message [none in this case, 'idling']

Fig. 1: Six main GMDSS channels are saved as 'Favourites' in SDRC software for parallel reception. Here, Olympia Radio from Greece booms in on 16804.5kHz, with the demodulated audio feeding input #6 of the BCS GMDSS decoder via VAC #6. Fig. 2: Centre frequency set to 1700Hz, low to 1500Hz, High to 1900Hz – resulting in a bandwidth of 400Hz. The signal of Finisterre Radio on 8414.5kHz matches these values, which leads to a perfectly decoded message if ...

Sign up to our FREE email newsletter at www.radioenthusiast.co.uk

126 126 122 -> end of message
111 -> error-check character [ECC]

After a look-up in the codebook this turns into:

Format: Individual call
Address [to]: 210761000
Category: Safety

Self MMSI [from]: 005030001
First telecommand: Test

Still not much enlightenment. But BCS-GMDSS is at your service. It looks up all the cryptic numbers at different sources, even tapping the official ITU webpage to enrich the vessel's MMSI with its stunning multitude of information. Wrapping it up, decoding and looking-up in an internal codebook (Coast stations) as well as in ITU sources (vessels), the above mentioned 23 symbols come out in full glory reading:

[2021-11-21 14:59:43] 12577

Symbols: 120 120 021 007 061 000 000 108 000
050 030 000 010 118 126 126 126 126 126
126 122 111

Self MMSI: 005030001 - Australia - JRCC
AUSTRALIA 26 20' 48" S 120 33' 52" E 13669 km,
92 deg

Address: 210761000 - Cyprus

Ship: SALT LAKE CITY | Callsign: C4DS2 | MMSI:
210761000 | Cyprus (Republic of) (CYP) | Vessel
ID: 9314129 | EPIRB: BE1 | 06/12/2017

Class: Merchant | Bulk carrier | | 89076 tons | 26
persons | INMARSAT C MINI M INMARSAT M VHF
DSC | 24 hr service

Owner: NOBEL NAVIGATION CO LTD POB 50132
LIMASSOL CYPRUS

Misc: Former Name: THALASSINI NIKI | EPIRB
ID: 210761000 | Telephone Bands: STUV | AAIC:
GR14 | CO | |

Format: Individual call Category: Safety First
telecommand: Test

Now for some features of the software, plus
some hints to make the most out of it.

The Multi-Channel QApproach

BCS-GMDSS offers up to eight channels in parallel, which by default are set to the main six GMDSS channels plus two with only rarely traffic observed, also on 2MHz. Those channels are fed by an SDR, ideally covering the whole range from 2MHz to 17MHz, alias-free. In this range you must place the up to eight channels, RX1 through RX8, and have their output set to VAC1 through VAC8. The inputs of the decoder must match those VAC numbers.

Take some care to think about mode, tuned frequency, audio frequencies and bandwidth. Mode can be USB, CW-U or FSK, whatever your SDR's software offers. It is, however, mandatory that the centre frequency of the audio output *must* match the centre frequency of the input of the decoder! Otherwise, there will be no decoding.

I am using free SDRC software to control the radio, easily providing all eight channels via the

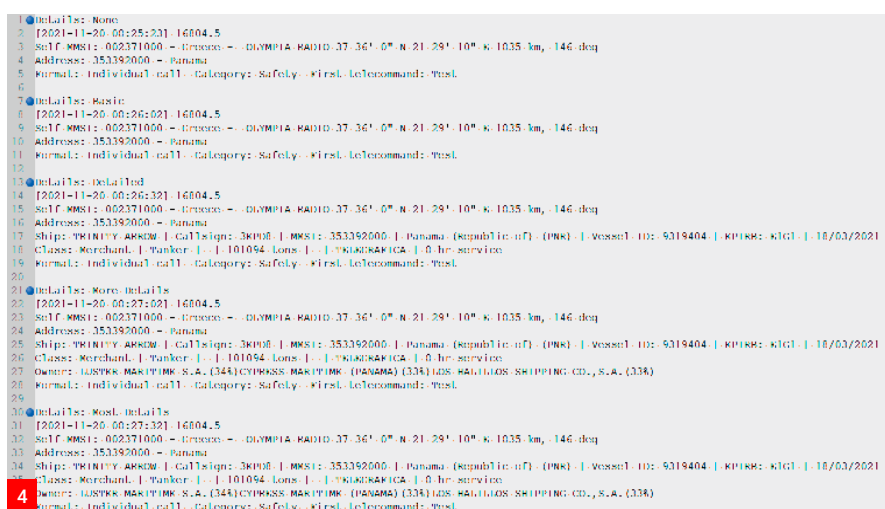
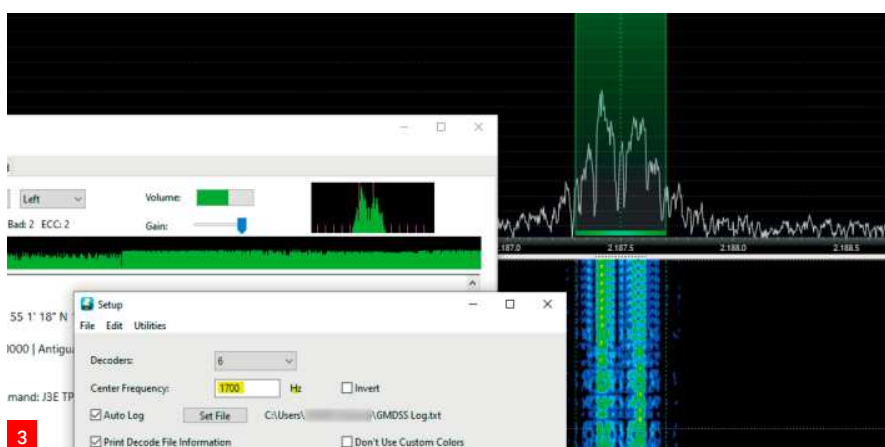
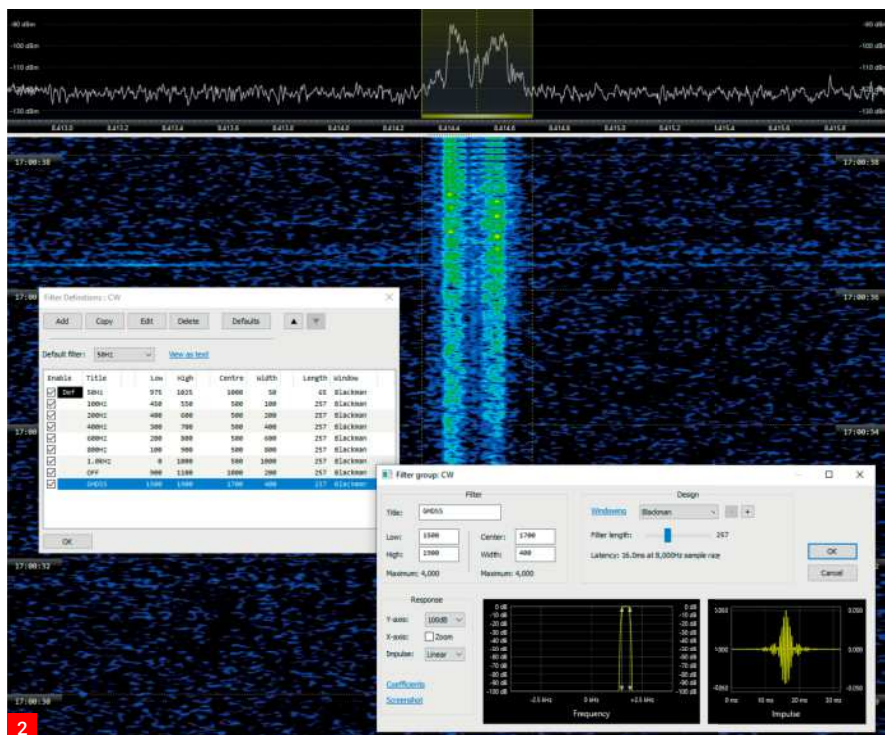
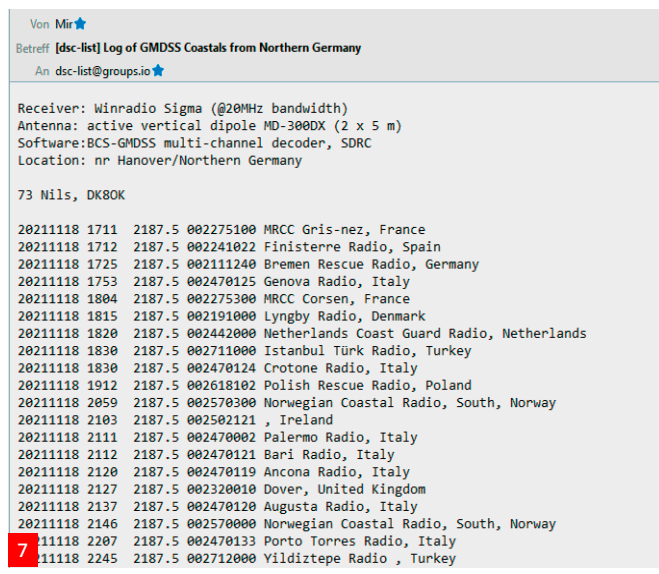
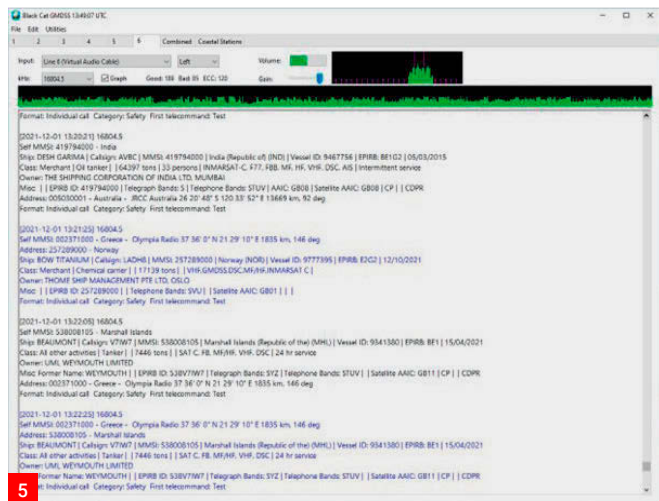

Fig. 3: ... the decoder's centre frequency has been also set to the matching 1700Hz.

Fig. 4: Same message received - at different degrees of details given by BCS-GMDSS.

Read more radio news and reviews at www.radioenthusiast.co.uk/news



VAC software. The SDR is tuned to CW-U mode and a bandwidth of 400Hz, giving some room for stations that might deviate by some 10Hz from the assigned channel for which the decoder is automatically compensating for. With this setup (see Figs. 2 and 3), the frequency readout shows the assigned channels, plus centre frequencies of decoder and receiver are matching (here 1700Hz, as ITU recommends). The bandwidth offers a good balance of SNR and tolerance for stations with a slight offset. Your mileage may vary in some respects, e.g. you may prefer SSB-USB mode, or your software has a BFO if you use CW. You may also use the wrong sideband (LSB instead of USB) with your receiver – but then you

must tick 'Invert' in the decoder's Setting menu as it then changes Mark and Space frequencies. **Messages: At your Service!** BCS-GMDSS cleverly combines a most powerful decoder with some extras to calm the rogue waves of decoded information. First, you may reduce (or extend) the degree of information you fetch from the ITU page: Edit -> Settings -> MMSI Lookup. It is very interesting to see the maximum of data ('Most Details'), but for everyday monitoring just 'Basic' or 'Detailed' may run the show. See Fig. 4 for the differences. The second step is to distinguish the vessels from the coastal stations by colour. I set the latter ones to show up in blue, see Fig. 5.

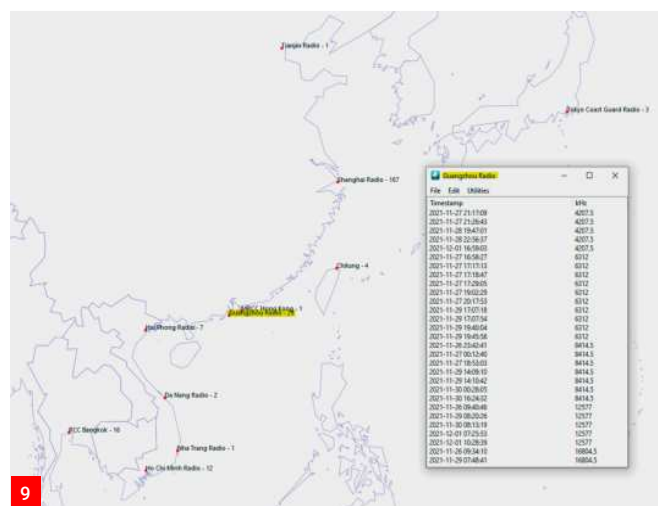
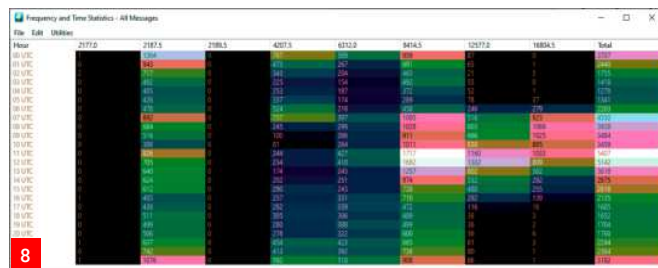

Fig. 5: Coast stations can be set to a different colour making it easy to distinguish them from the vessel's messages. Fig. 6: Here the decoders Loggings Database has been searched for messages on one channel, 2187.5kHz (cutout). Fig. 7: Socialising – messages can be exported in the format matching this of dsc-list@groups.io Fig. 8: Result of some days' monitoring in the late November/early January with nearly 66,000 decoded messages is presented by BCS-GMDSS as a heatmap. Fig. 9: The map, zoomed into a part of Asia. Guangzhou Radio had been double-clicked to show each message with date, time, and frequency in a pop-up window. Fig. 10: Vesselfinder's free [iOS] app is covering information from mostly land-based VHF monitors ... Fig. 11: ... whereas the subscription option floods with all messages, received from satellites – a stunning difference at a matching price tag. Fig. 12: Oil products tanker Imperious received on 16,804.5kHz, searched and found passing Banda Aceh/Indonesia on its way from Pasir Gudang/Malaysia to Fujairah/UAE. Website MarineTraffic received this information by land-based AIS monitoring and enriches it with a photo of the vessel plus some other information.

Database: GreatHub for Great Information

Next, BCS-GMDSS offers a Coastal Stations database. It is a real database in which, for example, each column can be sorted and exported as each different field for further processing in databases such as Access. This 'Loggings Database Search' is like a super tanker, containing all your logs, which can be queried for each column, also combining different criteria. This is the most powerful database any GMDSS decoder has on board, see Fig. 6. Another fine feature of the software is its ability to export logs in the format used by the DSC group, Fig. 7. <https://groups.io/g/dsc-list>

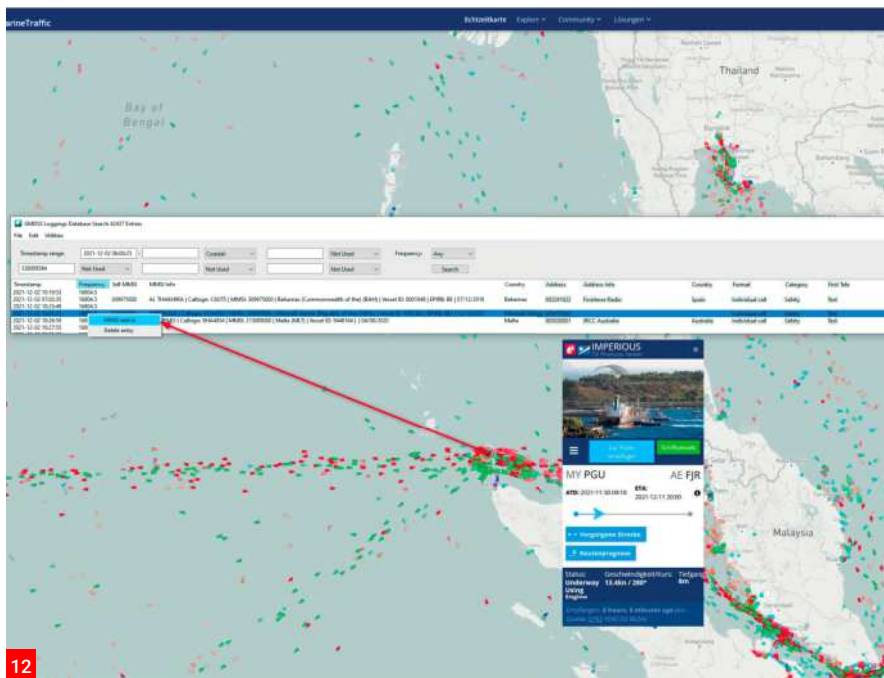
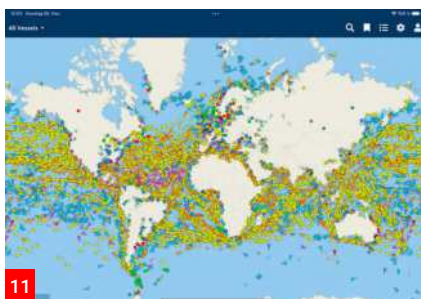
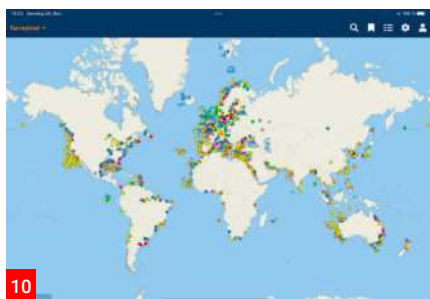

Fig. 13: Only 20 minutes after reception and reporting this via e-mail, this nice QSL from RCC Australia landed in Nils' post-box. Fig. 14: CBV from Valparaiso/Chile sent this QSL card after 24 hours. Fig. 15: This beautiful QSL from MRCCL Klaipeda needed only 18 minutes to be received. Additionally, the Lithuanian Navy answered just as sovereign as casual the state-loyal question "Is it even allowed to listen?"

There are also some basic statistical tools onboard, e.g., a summary of all stations or all Coastal stations received, enriched with some additional data, plus a Frequency and Time Statistics window of all messages or just Coastal stations. It is interesting to see the different congestion/propagation of each channel, conveniently presented by a heatmap, Fig. 8.

Where are they Cruising?

The location of most Coastal stations is openly available, and their geographical coordinates are internally looked up by the software – even calculation of the distances to your location (Edit -> Settings -> Latitude:/Longitude:) is done automatically. BCS-GMDSS even puts all received Coastals onto a basic map, showing the name of the station, followed by the number of receives – see screenshot, Fig. 9.

But where are the vessels cruising? They only rarely transmit their location in GMDSS

on HF. But if they have an AIS, or Automatic Identification System, you have a fair chance to get the actual location. This system comes in two tastes: System AIS and LRTI (links below), or Long Range Identification and Tracking. AIS is using VHF. Propagation restricts the range to some ten kilometres. LRTI is using satellite (INMARSAT).

<https://tinyurl.com/3ahprya3>
<https://tinyurl.com/24mce7cx>

There are some webpages (links below) where you get at least AIS for free – just to mention VesselFinder, VesselTracker and MarineTraffic. Their business model is to offer subscriptions for one year at a price of about \$1,200 US for LRTI (satellite) data, aimed mainly to the professionals. But most of those companies offer (limited) access to their AIS data for free. Figs 10 and 11 show the difference.

www.vesselfinder.com
www.vesseltracker.com
www.marinetraffic.com

BCS-GMDSS makes it easy to look up each MMSI: just point to this number, double-click it, and choose 'MMSI Search' in the menu then popping up. This leads you right to the internet, automatically googling this MMSI. The first entries will suggest the usual suspects of MarineTraffic et al.

With a bit of luck another click will show the vessel's position at this very moment (AIS), Fig. 12. If it is located only by satellite, you get only some older data for free, mostly 7 to 10 days old. Wait those days, try it again, and you often will get the position of the vessel at time of reception!

The BCS-GMDSS decoder offers many more features with a high utility value, such as the possibility to decode audio files in time lapse with at least a factor of ten, an autolog function as well as options to influence the sensitivity.

I have now tested the decoder intensively on all channels over several weeks, collected and processed a total of more than 65,000 messages, received beautiful DX (and, yes, QSLs) and generally had a lot of fun with this unique and innovative tool, which once again sets standards and is unparalleled even in the professional field.

Good work, Chris, good work! **PW**

Michael Jones GW7BBY
michael@gb2mop.org

Attenuators are very useful tools for testing and construction of radio equipment, something brought home to me since the completion of a home-built signal generator and purchase of the tinySA Spectrum Analyser and NanoVNA Vector Network Analyser. In this article I want to look at design and construction of fixed attenuators, but will take a brief look at variable attenuators at the end. A selection of fixed attenuators for BNC and SMA connections is shown at Fig. 1.

Let us first of all take a look at what attenuators do and why you need them. An attenuator takes a signal at its input, and at the output the signal is reduced by a specified number of decibels (dB) without introducing distortion. You might want to use an attenuator to take measurements, to protect the measuring device, to protect the device under test or to match different impedances. Attenuators can be fixed, fully variable or variable in known steps of attenuation: -0.5dB , -1dB , -10dB , etc. A switchable attenuator is often used in the first stage of a receiver to prevent overloading the subsequent RF amplifier stages. Sometimes such receivers have no RF gain control (Trio/Kenwood R 1000, Yaesu FRG-7) but allow the RF stages to run at full gain and rely on the attenuator for control. An attenuator can be balanced or unbalanced, those considered in this article are unbalanced. Fixed attenuators can be asymmetrical and used to match unequal impedances. These may be permanently built into a circuit or used as discrete units between pieces of test equipment of differing impedances, commonly 50Ω to 75Ω .

Measurement

When aligning a radio, you will inject a signal at different stages and measure its level, commonly at the output of a stage or via the S-meter. You will want to determine what happens when you reduce the input voltage by a specified amount, say 6dB . So, you insert a 6dB attenuator in line between your signal source and the radio antenna. You can insert a number of attenuators in series and add their values together to obtain the necessary attenuation.

Let's say your radio specification claims it can resolve a $1\mu\text{V}$ signal. $1\mu\text{V}$ is -107dBm . If your signal generator only goes down to -80dBm , you can insert attenuators to the value of 27dB between the signal generator and the radio antenna giving a total attenuation of -107dBm .

Protection

It is often necessary to ensure the signal levels input to a device do not exceed a specified level to avoid damage to sensitive devices or to prevent distortion.



Attenuators

Michael Jones GW7BBY asks "We spend a lot of time trying to make signals louder and receivers more sensitive, so why do we want a device to reduce the amplitude of a signal?"

Many RF measuring instruments can easily be damaged by applying too much power to them, spectrum analysers being a good example. The tinySA, for instance, should not be subjected to inputs greater than 0dBm ($223\text{mV}_{\text{RMS}}$), more than 10dBm (700mV into 50Ω or 10mW) will definitely do damage. Perhaps you check a signal of interest on an oscilloscope to get an idea of its amplitude. Say it's about 200mV pk-pk or -10dBm ; it is recommended that tinySA inputs should be less than -25dBm to prevent the appearance of mixing products in the display. A fixed attenuator or a combination of attenuators adding up to 15dB will achieve this.

What sort of Volts?

I've just mentioned Volts and dBm in the same sentence above. You will often hear people say, or see written, something like, " 20dBm is 2.23Volts " or " -30dBm is 7millivolts ". Go and look at a 20dBm signal on your oscilloscope and what do you see? 6.325Volts ! It can be confusing.

You have to remember that a) there are three ways of expressing an AC voltage: Root Mean Square (RMS) [1], Peak (pk) or peak-to-peak (pk-pk) and b) people are often lax in specifying how they are measuring the voltage. Usually, when talking about dBm's (Power in milliwatts) the equivalent voltage in a 50Ω system would be in

Volts RMS (V_{RMS}). When we talk about a receiver having a sensitivity of $1\mu\text{V}$, that is $1\mu\text{V}$ RMS in a 50Ω system or -107dBm .

Simply, the V_{RMS} value delivers the same power as the same DC voltage, sometimes called a DC equivalent voltage. Vpk-pk is the value shown on your oscilloscope measured from the bottom of the negative cycle, the lower 'peak' of a sinusoidal waveform to the top of the positive cycle or peak, i.e. peak-to-peak. Vp or peak value is measured from the 0V line to the top (peak) of the positive cycle, Fig. 2.

Most inexpensive multimeters use an averaging technique when reading an RMS voltage or current. This is accurate enough for pure sine waves, but inaccurate, probably low, for other waveforms. A true RMS meter will be more accurate.

I'm not getting into the details of the RMS calculations, the full formulas (10) for calculating V_{RMS} from Vp and Vp-p are at the end of the Formulas sidebar. However, simplifying for sine waves: $V_{\text{RMS}} = 0.707 \times Vp$ or $0.3536 \times Vp\text{-pk}$. Returning to the 6.325V at the start of this chapter, the opening statement should have been " 20dBm is $2.23V_{\text{RMS}}$ " and being pedantic, "*in a 50Ω System*". Now, $6.325\text{Vp-pk} \times 0.3536 = 2.236\text{V RMS}$. Note that these rules only apply to sine waves, for complex waveforms you will have to brush up your calculus! (Formula 11)

Sign up to our FREE email newsletter at www.radioenthusiast.co.uk

Fig. 1: Attenuators, left SMA, middle BNC and right home-made as described in this article. Fig. 2: Voltage relationships on sine wave. Fig. 3: Pi attenuator circuit. Fig. 4: T Attenuator Circuit. Fig. 5: I Attenuator Circuit. Fig. 6: O Attenuator Circuit. Fig. 7: PCBs for T and Pi Attenuators. Fig. 8: Through hole resistor formed for Surface Mounting. Fig. 9: Enclosure parts. Fig. 10: Parts ready for assembly. Fig. 11: nanoVNA in enclosure showing BNC connectors. Fig. 12: Completed 6dB and 10dB attenuators. Fig. 13: 15MHz signal at -5dBm. Fig. 14: 15MHz signal with 10dB attenuator inserted. Attenuation is exactly 10dBm. Fig. 15: Step attenuator circuit. Fig. 16: Step attenuator removed from Marconi signal generator. Fig. 17: Homemade step attenuator using surplus attenuator. Fig. 18: Attenuator circuit commonly used in meters. Fig. 19: Piston attenuator. RF is input at the cap on the right (Removed). Fig. 20: Pick-up coil in piston attenuator. The coil is moved back down the cylinder to increase attenuation. Fig. 21: PE4302/4312 outline. Fig. 22: PIN Diode attenuator circuit.

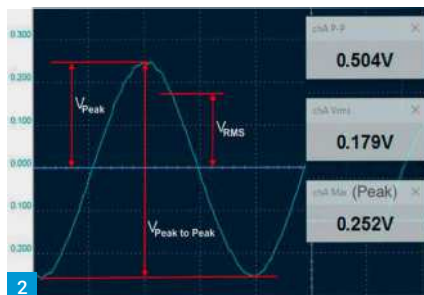

as 'W' for watts to dB so that 0dBW = 1 Watt, 0dBV = 1 Volt and so on. 10dBW is 10dB relative to 0dBW (1 Watt), which = 10Watts. 10dB was a convenient choice for an initial comparison, but the ratio progresses logarithmically. In terms of power it is useful to remember that a change of 3dB corresponds to a doubling of power, expanding on the previous example 3dBW = 2 Watts, 6dBW = 4 Watts, 9dBW = 8 Watts. If we talk about power being doubled from, say, 12 to 24 Watts: that is an increase of 3dB. Notice that there is no qualifier, such as 'W' or 'V' after 'dB' indicating that this is a relative, rather than an absolute definition. Equally, a minus value such as -3dB indicates a halving of the original power level. A useful table is shown at Table 1. See also Formula 1 for the ratio of two powers.

dBW might be suitable for describing transmitter outputs, but for receivers and interstage values dBm is more useful, being decibels relative to 1 milliwatt. dBm can also be expressed as dBmW, but the 'W' is usually omitted as milliwatts are assumed. However, if we want millivolts then we use dBmV. For completeness the expression might be extended to '3dbm 50Ω' so that we know we are dealing with a 50Ω system.

For voltages the ratios are different (see Formulas 2 & 3). For 0dBV = 1 Volt, 6dBV is a doubling = 2 Volts, 12dBV is a further doubling to 4 Volts. It took me a while to remember that a doubling in power = 3dB, while a doubling of voltage = 6dB. These are approximations and are close enough for most everyday calculations. If greater accuracy is needed, or the ratio, such as 2.2dB does not fit neatly into the approximations, then you will have to get your calculator out. The voltage rule also applies to current (Formula 4).

A useful feature of decibels is that they can be added and subtracted. If, for example, you have a radio with an RF amplifier stage with 9dB of gain followed by a second RF Amplifier with 6dB gain, then a mixer with a loss of -3dB and IF amplifier with 12dB gain followed by a bandpass filter with loss of -3dB. If you add the dBs together: 9 + 6 - 3 + 12 - 3dB, you will see that the overall system gain is 21dB.

Practical Attenuator Circuits

There are two principal types: either Pi or Tee networks, Figs. 3 and 4. As far as I can tell there is nothing to choose in terms of performance between these two networks. For completeness sake

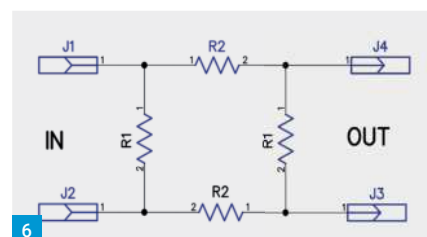
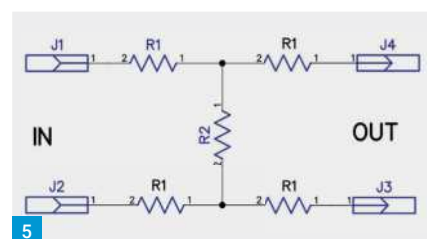
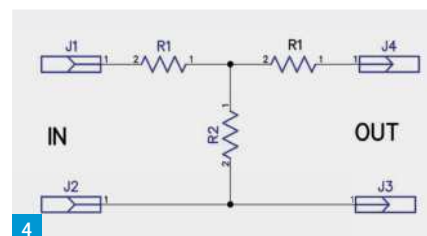
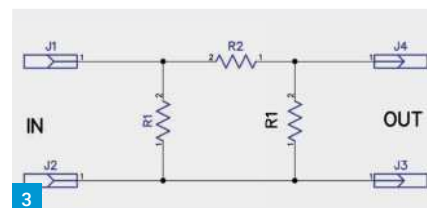

'H' and 'O' attenuators are shown at Figs. 5 and 6. These are used in balanced line applications. Note that for attenuators where input and output impedances are the same ($Z_{in} = Z_{out}$) both R1's are the same value.

While we are thinking about formulas, it is useful to remember that: $dBV = \sqrt{dBW \times Z_o}$, where Z_o is the system impedance, 50Ω in this example, so



that $6\text{dBW} = 4\text{W}$; $\sqrt{4 \times 50} = 14.14\text{V}_{\text{RMS}}$

To calculate the values for the resistors in Pi and Tee attenuators use the Formulas 5 and 6 shown in the sidebar. R1 and R2 refer to the resistors shown in Figs. 3 and 4. Zo is the system impedance.

These formulas require some nifty finger work on the calculator to enter the $10^{\text{dB}/20}$ and $10^{\text{dB}/10}$ values. These can be simplified to a constant or 'K' value, which makes calculator entries easier (Formula 7). Formulas 8 shows the application of 'K' values to Pi attenuators.

For most standard applications the tables found in RSGB and ARRL handbooks or online will be fine. **John Parfrey MOUKD's** online Calculator (URL below) is very useful as it gives the precise resistor values as well as the nearest preferred values in the E12 to E192 ranges with the calculated error. As a guide, **Table 2** gives resistor values for some commonly used attenuators. You will only really need the formulas for precise, non-standard attenuators or for asymmetrical impedance matching.

<https://moukd.com/calculators>

The sort of attenuators discussed here use low wattage resistors and are only suitable for low level signals in the milliwatt range. The same principles apply for higher power attenuators except that resistors must be rated accordingly and heat sinking may also be needed.

PCBs

I generated two PCBs, one for Pi attenuators and one for Tee attenuators. You will see, **Fig. 7**, that they are intended for Surface Mount (SMD) resistors as I may want to use these well into the UHF region. Through-hole resistors can be used by mounting the resistors 'SMD fashion', **Fig. 8**. These particular circuit boards have been laid out and



etched at home. I no longer do home etching of PCBs but get them made by one of the many manufacturers of quality PCBs such as JCL PCB.

Enclosures

The enclosures I have chosen to use are extruded aluminium with slots to accept a circuit board and come complete with end-plates, **Fig. 9**. When assembled they make a robust and professional looking component. **Fig. 10** shows all the required parts.

Connectors

The attenuators described here use BNC connectors. You can use SMA or N type connectors if you wish. I note that N types will fit the enclosures without the need for the end-plates. Against this, N

types are less common on test equipment so will need more adapters. However, I have rehoused my NanoVNA and tinySA in enclosures **Fig. 11** (To be described in a future article) with BNC connectors and will focus on these. It may well seem intuitive having bought a NanoVNA or tinySA to utilise their SMA connectors, but there are good reasons for not doing so.

SMA's are only specified for a limited number of connection cycles, about 100 for good SMA's, substantially less for cheap ones.

Their specifications only hold if the nuts are tightened to a specified torque.

Attaching heavy adapters, joined to heavy cables, even RG58 is heavy compared to an SMA, may put undue stress on the SMA and its attachment to the PCB.

Using adapters introduces a risk of losses, poor connections and impedance mismatching. They also add weight.

The standard connector used on most test equipment, certainly on mine, is the BNC, so it makes sense to standardise on these.

SMA's are really intended for interconnections between modules within a piece of equipment.

The attenuators I have made, **Fig. 12**, have a male BNC at one end and a female BNC at the other end. This makes the attenuators convenient to connect directly to my test equipment. However, they are easier to make with female connectors at both ends and will still work well in line with test leads or with suitable adapters.

Performance

There is no reason why these attenuators shouldn't operate well into GHz regions. **Fig. 13** shows a 15MHz signal at -5dBm on my TinySa Spectrum

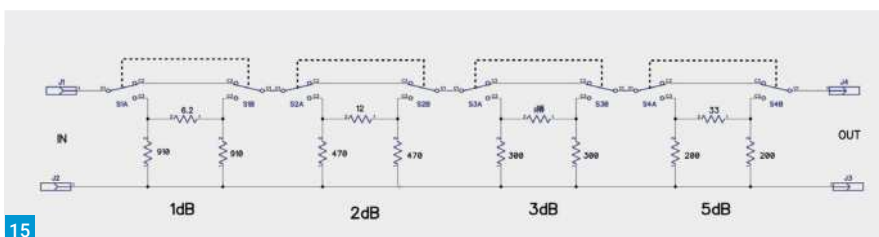
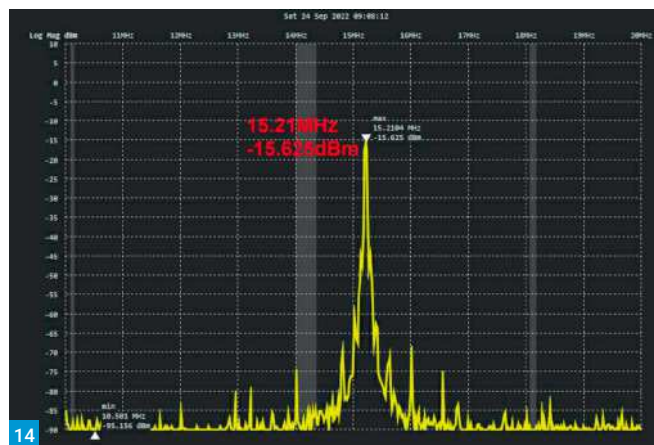
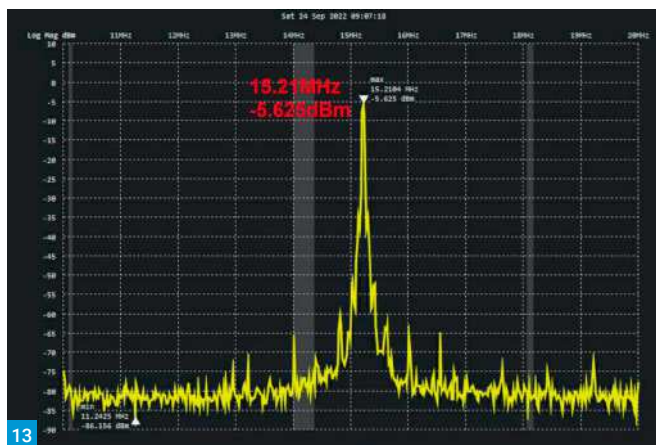

Analysers. Inserting a 10dB attenuator reduces this very nicely by 10dB, **Fig. 14**. VSWR is less than 1.02:1 up to 900MHz as measured on my NanoVNA.

Variable Attenuators

Variable attenuators can use stepped resistors, variable piston, digital techniques, or PIN diodes. The basic switched step attenuator is very effective and if well made, operates well into the VHF region. The example circuit, **Fig. 15**, shows four sections: 1, 2, 3 and 5dB. Further sections can be added as needed. Sensible values might be 1, 2, 3, 5, two 10dB and three 20dB sections, which will give 0 to 91dB attenuation in 1dB steps. The upper frequency range will be determined by careful attention to screening the different sections.

Old signal generators such as the Marconi TF995, have a stepped attenuator good to over 200MHz, **Fig. 16**. These can be built into a suitable enclosure to make a laboratory variable attenuator.

I made this switched attenuator, **Fig. 17**, using an attenuator obtained from Anchor Surplus in Nottingham years ago before they stopped selling radio-oriented gear, I later discovered that it is, in fact, from a Clansman test set. It works very well. I would not normally condone the stripping of older equipment for parts. I would not want to offend special interest groups that collect test equipment, nor would I want to destroy a historically important piece of equipment but there are generally plentiful supplies of these signal generators and while they can be used for repair and alignment, a modern piece of equipment will do a better job and be more reliable. The type of attenuator shown in **Fig. 18** is often used to switch ranges in



metering circuits. It is not suitable for RF applications as the impedance is not constant.

Piston Attenuators

Piston attenuators are not commonly used at HF these days, but they are still used at UHF frequencies. They have the advantage of being continuously variable and very accurate if well made. Against this they are complicated mechanically to set up correctly. An HF piston attenuator as shown at **Fig. 19**. The end cap, on the right, contains the RF feed coil. A pick-up (either capacitive or inductive) is fixed on the moving member, **Fig. 20**, that is slid in or out by the rack and pinion assembly. The further the pick-up is from the input, the greater the attenuation. Some older quality signal generators, both Hewlett Packard and Marconi, use piston attenuators that can be removed from a scrap unit and incorporated into an enclosure to make a useful piece of test equipment.

Digital Attenuators

A very effective step attenuator that I have used in a signal generator project is the PE4302/4312. The 4302 operates from DC to 4GHz, it is a 6-bit device offering 0 to 31.5dB attenuation in 0.5dB steps, **Fig. 21**. The 6-bit control lines can be set with simple switches or by a processor such as an

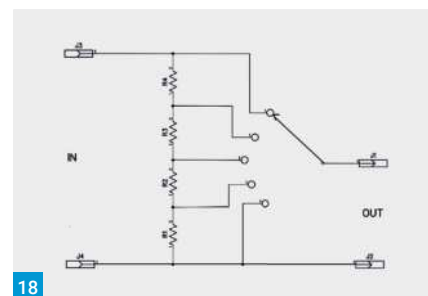

Arduino or PIC. PE4302/4312 modules are readily available on eBay as are the PE4302/4312 surface mount ICs. They can be cascaded to achieve higher levels of attenuation. I used four of them in a signal generator project to achieve 124dB attenuation from DC to >4GHz. The PE4302 is an obsolete part, but still in plentiful supply. It has been replaced by the improved PE4312, which is pin for pin compatible.

Pin Diode Attenuators

A stepless attenuator can be realised with PIN diodes. Referring to **Fig. 22**, it can be seen that the diodes (D1, 2 & 3) stand in place of the resistors in a passive Pi attenuator. The capacitors couple the

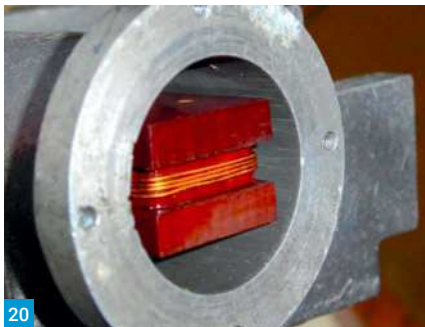

20

Formulas

(1) Ratio of two powers:

$$\text{Ratio}_{dB}(\text{power}) = 10 \log \left(\frac{P_{out}}{P_{in}} \right)$$

(2 & 3) Ratio of two voltages:

$$\text{Ratio}_{dB}(\text{Volts}) = 10 \log \left(\frac{V_{out}}{V_{in}} \right)^2$$

$$\text{Ratio}_{dB}(\text{Volts}) = 20 \log \left(\frac{V_{out}}{V_{in}} \right)$$

(4) Ratio of two Currents:

$$\text{Ratio}_{dB}(\text{Current}) = 10 \log \left(\frac{I_{out}}{I_{in}} \right)^2$$

(5) Pi Attenuators where $Z_{in} = Z_{out}$:

$$R1 = Z_0 \left(\frac{10^{\frac{dB}{20}} + 1}{10^{\frac{dB}{20}} - 1} \right) \quad R2 = \frac{Z_0}{2} \left(\frac{10^{\frac{dB}{10}} - 1}{10^{\frac{dB}{20}} - 1} \right)$$

(6) Tee Attenuators where $Z_{in} = Z_{out}$:

$$R1 = Z_0 \left(\frac{10^{\frac{dB}{20}} - 1}{10^{\frac{dB}{20}} + 1} \right) \quad R2 = 2 \times Z_0 \left(\frac{10^{\frac{dB}{20}} - 1}{10^{\frac{dB}{20}} + 1} \right)$$

(7) Constant "K" Value

$$K = 10^{\frac{dB_{atten}}{20}}$$

(8) Pi Attenuator using "K" Value:

$$R1 = Z_0 \left(\frac{K+1}{K-1} \right) \quad R2 = Z_0 \left(\frac{K^2-1}{2K} \right)$$

(9) Pi attenuator where Z_{in} and Z_{out} are not equal, note that R1 is the input resistor, R3 is the output resistor and R2 is the series resistor:

$$R1 = Z_{in} \left(\frac{K^2-1}{K^2-2K\sqrt{\frac{Z_{in}}{Z_{out}}}+1} \right)$$

$$R2 = 0.5\sqrt{Z_{in} \times Z_{out}} \left(\frac{K^2-1}{K} \right)$$

$$R3 = Z_{out} \left(\frac{K^2-1}{K^2 - \frac{2K}{\sqrt{Z_{in} \times Z_{out}} + 1}} \right)$$

(10) V_{RMS} formulas for sine waves:

$$V_{RMS} = \frac{1}{\sqrt{2}} \times V_p = 0.707 \times V_p$$

$$V_{RMS} = \frac{1}{2\sqrt{2}} \times V_{p-p} = 0.3536 \times V_{p-p}$$

$$V_{RMS} = \frac{\Pi}{2\sqrt{2}} \times V_{p-p} = 1.11 \times V_{p-p}$$

(11) V_{RMS} formula for complex Waveforms

$$V_{RMS} = \sqrt{\frac{1}{n} \sum_{i=1}^n x_i^2}$$

Where n = number of samples under waveform
 x_i = Value of each sample

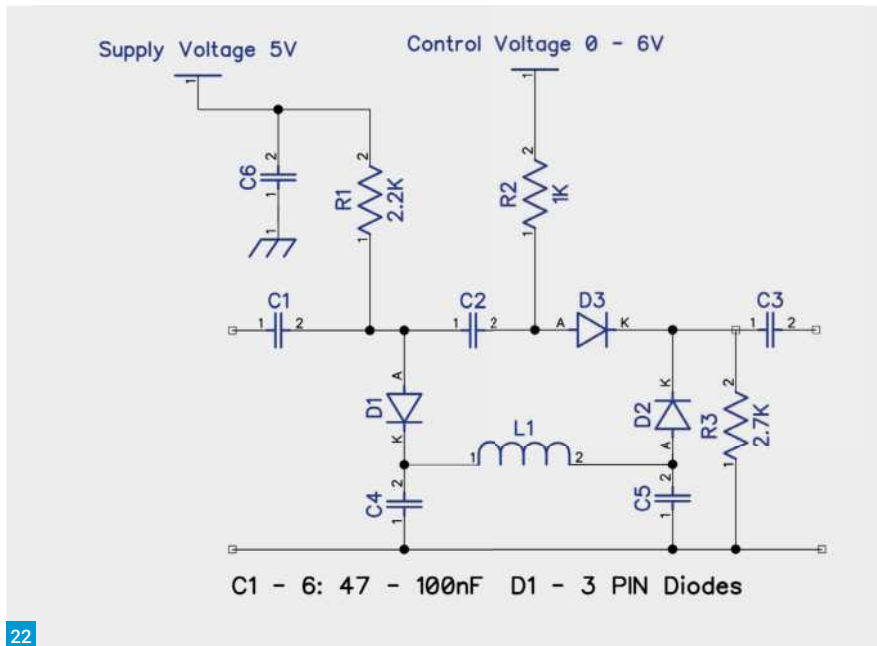

22

RF signal through the circuit, at the same time decoupling the DC control voltage from the signal path. L1 provides a DC path to bias D1 and D2 while providing RF isolation. When V_{in} is 0V, attenuation is at maximum as the current from the supply dominates turning D1 and D2 on to short the input signal to ground. Furthermore, D3 is reverse biased thus blocking the signal flow. Increasing V_{in} will at some point reverse bias D1 and D2 while forward biasing D3 thus allowing a proportion of the input signal to flow. These circuits are very useful in RF circuits as they are very repeatable and allow the attenuator circuit to be located at the ideal place in a given circuit unaffected by the distance to the front panel controls.

The values shown in the circuit are nominal and may need tweaking for your application, but provide up to about 20dB of attenuation. Unlike

dB	Power Ratio	Volts/Current Ratio
-20	x0.01 (1/100)	x0.1
-13	x0.05 (1/20)	x0.223
-10	x0.1 (1/10)	x0.32
-9	x0.125 (1/8)	x0.354
-6	x0.25 (1/4)	x0.5
-3	x0.5 (1/2)	x0.707
0	x1	1
3	x2	x0.413
6	x4	x2
9	x8	x2.818
10	x10	x3.162
13	x20	x4.467
20	x100	x10

Table 1: dB as power ratio and volts/current ratio.

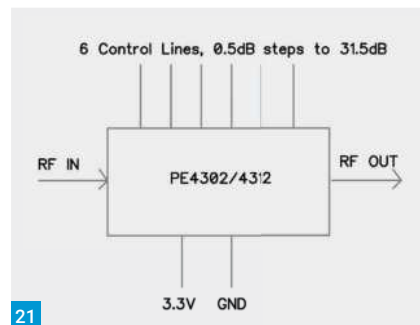

21

the passive attenuators previously described, this circuit will require external calibration if an exact degree of attenuation is required.

Conclusion

A collection of attenuators of common values are an invaluable tool on the test bench. They are easy to design and build. Attenuators are often integral parts of radio equipment where they match power levels and impedances.

References

1. RMS: arithmetic mean of the squares of the set of voltages measured under a waveform.
2. MOUKD calc: <https://tinyurl.com/4285ehbf>

dB	Pi attenuator		T attenuator	
	R1(Ω)	R2(Ω)	R1(Ω)	R2(Ω)
3	292.4	17.6	8.5	141.9
6	150.5	37.4	16.6	66.9
10	96.2	71.2	26	35.1
20	61.1	247.5	40.9	10.1
30	53.3	789.8	46.9	3.2

Table 2: Suitable resistance values for Pi and T attenuators.

ML&S

SAFE ONLINE SHOPPING. E&OE

Wessex House, Drake Avenue, Staines, Middlesex TW18 2AP.
MARTIN LYNCH & SONS LTD
 THE WORLD FAMOUS HAM RADIO STORE
0345 2300 599 E-mail: sales@hamradio.co.uk

WWW. HamRadio.co.uk



More NEW products from the Lynchy Stable

**STOP PRESS!!
Buddipole Killer?**

**NEW MyDEL JPC-7
Portable Shortwave
Antenna**

MyDEL JPC-7 (Dipole Version) covers 40-6m, 100W PEP. All contained in a small carry case for ideal portable use. Beautifully manufactured to a very high standard.

JPC-7: £339.95

See MLandS.tv for our full video review of this antenna.

See: HamRadio.co.uk/JPC



**New MyDEL JPC-12
Portable Shortwave Antenna**

MyDEL



MyDEL JPC-12 (Vertical Version) covers 40-6m, 100W PEP. All contained in a small carry case for ideal portable use. Beautifully manufactured to a very high standard.

JPC-12: £199.96

See MLandS.tv for our full video review of this antenna.

See: HamRadio.co.uk/JPC

mAT Y-200

160-6m High Speed Auto Tuner for Yaesu Radio £229.95



MyDEL G63 Micro Handle

It's TINY but built like a tank!
400-480MHz With programming cable, Mic/Earphone, USB-C chargeable.
Only £49.99

see: HamRadio.co.uk/G63



ZUM Radio Elite

Small and efficient Multi-Mode Digital Hotspot
Only £279.95

See: HamRadio.co.uk/ZUMRE



**NOW IN STOCK!
New! Acom 06AT**

1.5kW remote Auto ATU & 4-Way Switch
Powered by all Solid State Acom amplifiers.
£1150.00

See: HamRadio.co.uk/06AT



BACK IN STOCK! ANAN-7000DLE Mk11

100W SDR Transceiver (No Embedded PC)
£3299.99

See: HamRadio.co.uk/7000DLEnoPC



DigiRig Isolater

Eliminate audio noise caused by ground loops by isolating your PC from transceiver £29.95



**CHA LEFS (Lightweight End Fed Sloper)
EFHW - Chameleon Antenna**

The CHA LEFS is a six-band, no-tuner, High Frequency (HF) antenna for use on the 40, 20, 17, 15, 12, and 10 meter Amateur Radio Service (ham) bands. It's minimalistic design and lightweight components are intended for the serious backpacker and outdoor adventurer £229.99



DigiRig Mobile

Tiny new digital modes interface

- Combines audio codec, serial CAT interface and PTT switch
- Supports full featured CAT interface: PTT, bands, tuning etc. (not just VOX based PTT)
- Uses a single USB connection to computer minimizing the cables mess
- Serial computer aided transceiver (CAT) port can be configured for logic levels, RS-232, CI-V or TX-500
- Works with all major OS flavours: Windows, MacOS and Linux
- Permanently available independently from CAT port an open-collector PTT switch controlled by RTS signal of the COM port to interface Handies/Mobiles etc.
- Axillary connection points to CM108 codec
- Uses widely supported CP2102 serial interface & CM108 audio codec

For more details see HamRadio.co.uk/DigiRig



CG Antenna BL-49:1 Un-Un 600W

Tested by our own Richard 2E0SXX
Hi Power Matching Transformer suitable for Multi Band End Fed Half Wave antennas. Ideal for home or field use. All you need to do is add 10m to 40m of antenna wire - the Messi & Paoloni Dipoflex wire is ideal.
£69.95



MyDEL Solid Brass Key

MyDEL Morse Code CW Paddle Key
A compact but solid paddle capable of standing up to the rigors of portable operation as well as providing excellent service in the shack. Contact spacing is adjusted easily, without tools, via the large thumb-screws on either side of the paddle body. Spring tension is fixed for a light, precise action £109.95



**Short Wave Radio Deluxe
Morse Code Switch Key**

Stainless steel, electroplating polishing, 6.5 audio head.
..... £57.95



MyDEL

MyDEL SV4401A

Handheld Vector Network Analyser. 4.4G VNA with 7" Capacitive Touchscreen.
..... £389.95



Create RC5A-3P Antenna Rotor - Rotator

CREATE antenna rotator, AZ angle 370°, motor snail gearing, PC compatible.

Antenna rotator 110/230VAC 150VA, maximum vertical load 700kg, horizontal load 1000kg, rotating torque 155Nm, brake torque 1960Nm, worm gear at motor, variable speed 75-110 sec., reversing delay 3sec., mast diameter 48-63mm, 360° scale, preset, weight 7kg rotator and 2kg controller, needs 7 core cable (0.75mm2 up to 50m length, 1.25mm2 up to 80m length) £959.95



**New to ML&S
Windcamp Gipsy**

5-55MHz Portable dipole in a bag!

HF Portable dipole antenna. The antenna is design for operation in the 5-55MHz frequency range. The operating frequency is continuously adjustable giving you a full-size portable, horizontal dipole antenna. The antenna was designed with portable operation in mind. Windcamp wants to maximize your portable operating experience £71.95



It's NEW! The M&P UltraFlex 7 "Sahara" in white
Ultraflex 7 and 10 sahara (white).
£2.00 per metre.

Purchase 100m+ and get 10% off!



FOLLOW US ON TWITTER AND FACEBOOK HamRadioUK

You can now order from ML&S for delivery on a Saturday or Sunday!
Order before 2pm as late as Friday of each week and see it delivered at the weekend.



Watch our YouTube Channel on www.MLandS.TV

Web purchases: Just select Saturday or Sunday at the check-out.
Or call to place your order for Saturday or Sunday delivery on 0345 2300 599

**MARTIN LYNCH
& SONS LTD**

THE WORLD FAMOUS HAM RADIO STORE

Wessex House, Drake Avenue, Staines, Middlesex TW18 2AP. E-mail: sales@hamradio.co.uk. Opening Hours: Mon - Fri: 8.30am to 5pm. Sat: 9am to 4.30pm.

SAFE ONLINE SHOPPING. E&OE



ML&S

www.HamRadio.co.uk

0345 2300 599

International Tel: +44 1932 567 333

Call the team to discuss our excellent part exchange deals or if you have unwanted gear you want to sell.

YAESU

**ML&S Officially The Largest
UK Dealer & Distributor of
Yaesu Musen Products**

This month's Featured Yaesu Radio



**Yaesu
FT-710**
HF-6-4m all
mode 100W

See HamRadio.co.uk/FT710

- New! FT-710** Perfectly sized & simple to use. (The Guv'nor has one in his shack) **£1099.99 incl Speaker**
- Yaesu FTM-6000E**
Dual Band 50W 2/70 FM Mobile Transceiver..... **£239.95**
- Yaesu FTM-3000E** 50W C4FM/FM 144/430MHz Dual Band Digital Mobile Transceiver..... **£399.00**
- Yaesu FTM-200DE IN STOCK** Single RX C4FM Mobile..... **£349.96**
- Yaesu FTM-400XDE** Dual Band transceiver for 144/ 430MHz with the new C4FM/FDMA Digital Mode..... **£399.95**
- Yaesu FTdx101D & MP** Our current favourite Base Station from Yaesu. Choose between 100W & 200W versions **CALL for BEST PRICE!**
- Yaesu FTdx10 HF+6+4m Hybrid**
SDR Base Station..... **CALL for BEST PRICE!**
- Yaesu FT-891** HF/6m Base/Mobile **£679.95**
- FT-891+FC-50 Bundle**
Buy an FT-891 with an FC-50 Auto-Tuner and save! **Just £869.95**
- Yaesu FT-818ND** 6W QRP 160m-70cm
All Mode Transceiver with **FREE Legpegs** **£624.95**
- Yaesu FT-5DE** IPX7 Dual C4FM RX Handle **£399.95**
- Yaesu FT-3DE** Latest 5W C4FM/FM Handle **£299.95**
- Yaesu 70DE** C4FM/FM 144-430MHz Dual Band Handle..... **£169.95**
- Yaesu DR-2XE** C4FM Repeater. In stock at special prices **£CALL**
- Yaesu FT-65E** VHF/UHF 2m/70cm Dual Band FM Handle **£84.95**
- Yaesu FT-4XE** 5W VHF/UHF FM Portable Transceiver **£62.95**

Choose ML&S for the Big Three

For full specifications, photographs, reviews, shipping details and special offers see www.HamRadio.co.uk

or call the team on 0345 2300 599 for advice



KENWOOD

**ML&S Officially Appointed UK Sole
Distributor & Repair Workshop for
JVC-Kenwood's Ham Radio Products**

**This month's Featured Kenwood Radio
JVC-Kenwood TS-990S**



The Master Class HF/6m Flagship **£6399.95**

- Kenwood TS-990S** 200W HF/50MHz Transceiver **£6399.95**
- Kenwood TS-890S** The excellent TS-890S is now back in stock & **FRESH** off the Japanese production line **£3699.95**
- Kenwood TS-590SG** 160-6m Base with ATU **£1499.95**

ICOM

**ML&S Stock the Full Range of
New Icom Products**

This month's Featured Icom Radio **NEW**

New! Icom IC-T10

2/70 5W Handie
IP67 Waterproof rated.
Only **£199.95**
See: HamRadio.co.uk/ICT10



NEW! Icom AH-730
100W Remote Auto-ATU **£569.95**

- Icom ID-52E** The NEW Kid on the block, 2.3" display D-Star etc. It's a beauty!..... **£549.99**
- Icom IC-705** IC-705 5W QRP **£1399.95**
- IC-705 Bundle** Discount offers available. See Web for details.
- Icom LC-192** Multi-function Backpack. MyDEL MP-705 8 Amp PSU. mAT-705Plus Micro Auto-Antenna Tuner. VS-3 Bluetooth headset. Nifty MB-705NF Mount your Icom IC-705 at the correct angle for table top use. Prism IC-705 Cover.
- MyDEL QRAB** Quick release antenna bracket. **MyDEL IC-705** Carry Cage. **MyDEL Z-Mount**. Tilt Stand. **BP-272 & BP-307** Spare battery packs.
- Icom AH-705** Random wire auto tuner for IC-705..... **£309.60**
- Icom IC-7300** Best selling 100 Watt - HF/50/70MHz Transceiver with SSB / CW / RTTY / AM / FM **£1299.99**
- PTRX-7300**
High quality RF interface module for the IC-7300..... **£199.95**
- PTRX-9700 NOW IN STOCK** **£279.95**
- FREE SHIPPING QUOTE 'RCFREE'** in checkout
- Icom IC-7610** Brilliant Dual Band Transceiver..... **£3299.95**
- With **FREE SP-41** base speaker
- Icom IC-9700**
Base Station 2/70/23 all mode including D-Star **£1899.95**
- Icom IC-7100** HF/6m/4m/2m/70cm Base & Mobile Transceiver including D-Star with remote control head unit..... **£1124.95**
- Icom IC-R8600** New 100kHz-3GHz Receiver with SDR technology from IC-7300..... **£2599.96**
- Icom ID-5100**
Latest 2/70 D-Star Touch Screen Transceiver **£639.99**
- Deluxe Version also available

Deals on Yaesu Speakers & Microphones!

These speakers reproduce the high quality output sound these receivers generate and thereby providing clear and crisp audio for reliable communications on all HF and V/UHF.

Yaesu SP-10. £109.96
External Speaker for FT-991A/FT-991.

Yaesu SP-30. £94.96
Desktop loudspeaker, optically and electrically matching to the FTdx10 transceiver.

Yaesu SP-20. £129.95
External Speaker for FTdx3000D/FTdx1200.

Yaesu SP-101. £139.96
Desktop External Speaker. Maximum input: 7W. Impedance: 8 Ohm.



Yaesu M-70 Desktop Microphone. £129.95
Desktop Microphone for the family of Yaesu HF transceivers. The M-70 utilises a directional condenser microphone element which is specially tuned the frequency response to create clear and crisp audio for radio communication.

Yaesu M-100 Dual Element Microphone. £329.95
Features a hybrid design integrating both a high-quality Condenser and Dynamic element.

Yaesu M-90D Desktop Microphone. £179.95
Equipped with both a round 8-pin jack and an 8-pin modular jack. Supplied microphone cable (round 8-pin to 8-pin modular) can be connected to either jack of the M-90D. The M-90D does not require the SCU-53.

Yaesu M-1 Reference Microphone. £599.95
The ultimate, high-quality, innovative desktop microphone, dedicated to the most discriminating Ham Radio Operators. It features combined Condenser and Dynamic microphone elements.

Save £10 on each using code YSPOA at checkout



SOMETHING FOR THE WEEKEND...

Sign up to our mailing list at HamRadio.co.uk for weekly updates, bargains, news and much more!

Have you watched www.MLandS.TV yet?

Every week there's something new.



- Buy stuff (any stuff) via our website & get 1% CREDIT back on the money you spent after VAT
- You can use the CREDIT the next time you order via our website, or you can save your CREDIT for future purchases
- The CREDIT won't expire for a whole 12 months so you will have more than enough time to use it
- It's simple and it's FREE. You spend money with us via our website and we give you money back to spend on our website on further purchases.



For more information on our FREE MONEY offer see HamRadio.co.uk/CREDIT

ML&S are ALWAYS adding new manufacturers and products to our vast range



Wouxun KG-UV9K

2m + 70cm Handie Pro Pack £144.95
Now with 8.33 step for Airband Channel Spacing Changes.

Wouxun KG-UV8G

2m + 4m Handie Pro Pack £149.95
The original & the only 2+4m Handie - available from ML&S - Who else?

The Wouxun KG-UV8G is our best selling 2m & 70cm Handie in the U.K, so we persuaded the factory to offer the 2m+4m version as a 'ProPack' with all your favourite accessories and placed them inside a presentation box.



Pro Pack Bundles include:

- KG-UV9K or KG-UV8G Transceiver
- Two batteries
- Two belt-clips
- Software and transfer data cable
- Fast charger dock and Power Supply
- Hand speaker mic
- Battery eliminator
- Manual
- Wrist strap
- Leather case
- In-car charger
- SMA-PL259 adaptor
- Hands-Free kit

The New KG-UV9D Mate £139.95

Wouxun KG-UV980PL £279.95

with FREE Shipping

Hear those weak signals with bhi DSP noise cancelling products



PARAPRO EQ20

PARAPRO EQ20-DSP £259.95

Four product options are available.

The basic EQ20 and EQ20B can be used with the bhi Dual In-Line and Compact In-Line noise cancelling units.

NES10-2MK4 New NES10-2MK4 amplified DSP noise cancelling speaker. £129.95

Dual In-Line Dual channel amplified DSP noise eliminating module. £179.95

New DESKTOP MKII Amplified DSP base station speaker - 10 Watts audio. £219.95

New NEDSP1901-KBD Pre-wired low level retrofit audio DSP noise cancelling module. This module replaces the popular NEDS01061-KBD that many Yaesu FT817/FT-818 users have installed over the last 18 years. £129.95

Compact In-Line Compact DSP noise cancelling module with improved DSP algorithm giving even better noise elimination. £189.95



New! BHI NCH
Active Noise Cancelling Headphones. £39.95



New! BHI Wired Stereo
Communications Headphones. £19.95

Xiegu G106 HF QRP 5W Transceiver

In stock & ready to deliver to you door!
See HamRadio.co.uk/G106

Fancy an IC-705 but don't like the £1400 price tag? How about this ultra-compact device for only £349.95?



- High-performance SDR 16-bit circuit
- Compact, robust and user friendly
- General coverage HF receiver
- Transmit in all amateur radio bands 3.8~29.7MHz
- WFM broadcast receiving in 88-108 MHz
- Digital modes option capable
- Computer control ready

Sangean Products in store now!

NEW MODEL!! Sangean WFR-39

- FM-RDS/DAB/Internet Radio
- ATS (Auto Tuning System)
- Station Presets (99 FM/99 DAB/250 iRadio)
- Spotify Connect for Music Streaming
- Cloud Music (Podcasts/Amazon Music/Deezer/Napster/Qobuz/TIDAL)



Small & Compact!

Width: 166.2mm
Height: 108.3mm
Depth: 104.5mm
Weight: 1600g

£159.95. Stock due October 2022.
Order NOW for FREE UK delivery

ATS-909X2 £214.95

The Ultimate SSB / FM / SW / MW / LW / Air / Multi-Band Receiver.

The Discover 909X is the perfect world band radio to roam the globe with.



ML&S Now UK Distributor for Sangean

See www.HamRadio.co.uk for our full range of Sangean products



Antenna Disconnect

£115.00
Reduce the chance of station damage from lightning.



Dual Antenna Disconnect

£190.00
Reduce the chance of station damage from lightning surges.

METROPWR FXMASTER

£299.95
8-band equalizer with adjustable noise gate.



Radiosport Headsets

Whether for DXing, contesting, field day, or casual everyday use we think you'll agree Radiosport headsets have the features you want. ML&S are proud to have been appointed their distributor and have stock today.

All headsets are supplied with GEL Cushions giving extra comfort and FREE cloth covers.

- RS10SL Listen only stereo lightweight headset for CW ops..... £131.94
- RS20S Deluxe Dream Edition Stereo Headset only no boom..... £169.95
- Mini-XLR Lead set for any radio (Yaesu/Kenwood/Icom/Flex/Elecraft) from £69.95
- PTT-FS-RCA Foot switch with 7ft cable with phono plug..... £54.95
- PTT-HS-RCA Hand PTT Switch, 7 foot cable with phono plug..... £64.95
- RS60CF Deluxe Dream 10th Anniversary Edition Stereo Headset with boom... £239.95

How about an additional 3.5mm socket on the opposite ear cup to allow "teething" of another headset for a logger or maybe just an additional pair of ears?



ML&S are the sole UK distributors for the DVMega Range of products

DVMega EuroNode Hotspot.
Use your Radio everywhere anytime. The EuroNode is the most complete and multi-deployable hotspot at the moment. It has standard WiFi, and a LAN connection is available. £149.95

DVMega is a collective name for digital voice and data related kits and modules. C4FM, DMR and D-STAR is supported with more digital voice and data modes added all the time.

DVMega Globetrotter is a powerful digital voice communication tool that allows you to communicate from anywhere to anyone with just a simple internet connection. £139.95

DV Dualband (VHF/UHF) radio shield
This shield is compatible with Arduino UNO or MEGA. This module has a 10mW UHF and VHF transceiver on board. In combination with an Arduino you make your own stand-alone dual band hot spot. This module, together with the AMBE3000 forms the basis for a self-assembly D-Star kit transceiver. Just £119.95

DVMega Cast is a AMBE3000 based Multimode IP radio for DMR, D-Star and Fusion. The DVMega Cast is compatible with Ham radio networks like BrandMeister, DMR+, YSF, FCF, RCF, XRF, XLX, DSC etc. £319.95



New! AR600XL Only £199.95
Programmable Antenna Rotator. Ideal for lightweight V/U beams.

Tigertronics ST-USB £99.95

ALL sound card Digital and voice modes are supported by the SignalLink™ USB. This includes traditional modes such as RTTY, SSTV and CW (to name a few), as well as today's hottest new modes like PSK31, FT-8 and WSPR.



Buy with your required lead and get a discount off the bundle price.



MYDEL

MyDEL Headphone Stand
£11.95

Ideal to hang up your Heil, RadioSport or other headsets on your operating desk.

Made of aluminium alloy, with a cushioned rubber part to prevent the headphones from slipping.



EVEN LYNCHY HAS ONE ON HIS DESK.

ML&S Appointed Sole UK Distributor for CW Morse Keys!

There are over 35 different keys to choose from including Camel Back, Straight Keys, Micro Keys, Lightweight Keys, Heavy Duty Keys, Paddle Keys, Navy Keys & even Bullseye Keys. With such a huge & colourful range to choose from there's bound to be a model (or two!) to suit CW enthusiasts worldwide.



FROM ONLY £19.95

Heil Sound

ML&S are the official UK importer for Heil SOUND

- Pro-Set 7 Headphones..... From £239.95
- USB-stick facilitates the use of a PC to communicate on Dstar, DMR and C4FM! Just install BlueDV and use the PC-microphone & speakers to communicate to reflectors/talkgroups. Ideal solution to use on a laptop whilst travelling. Just £89.95
- Pro-Set 6 Headphones..... From £134.95
- Pro-Set IC Headphones..... £169.95
- Pro-Set Elite 6 Headphones..... £174.95
- Pro-Set Elite IC Headphones..... £189.95
- Pro-Set 3 Headphones..... £109.95
- PR-781 Microphone..... £189.95
- PR-40 Microphone..... From £299.95
- PR-40 Microphone New All Black Version... £299.95

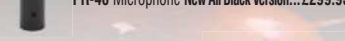

You can now order from ML&S for delivery on a Saturday or Sunday!
Order before 2pm as late as Friday of each week and see it delivered at the weekend.



Web purchases: Just select Saturday or Sunday at the check-out.
Dr. call to place your order for Saturday or Sunday delivery on 0345 2300 599

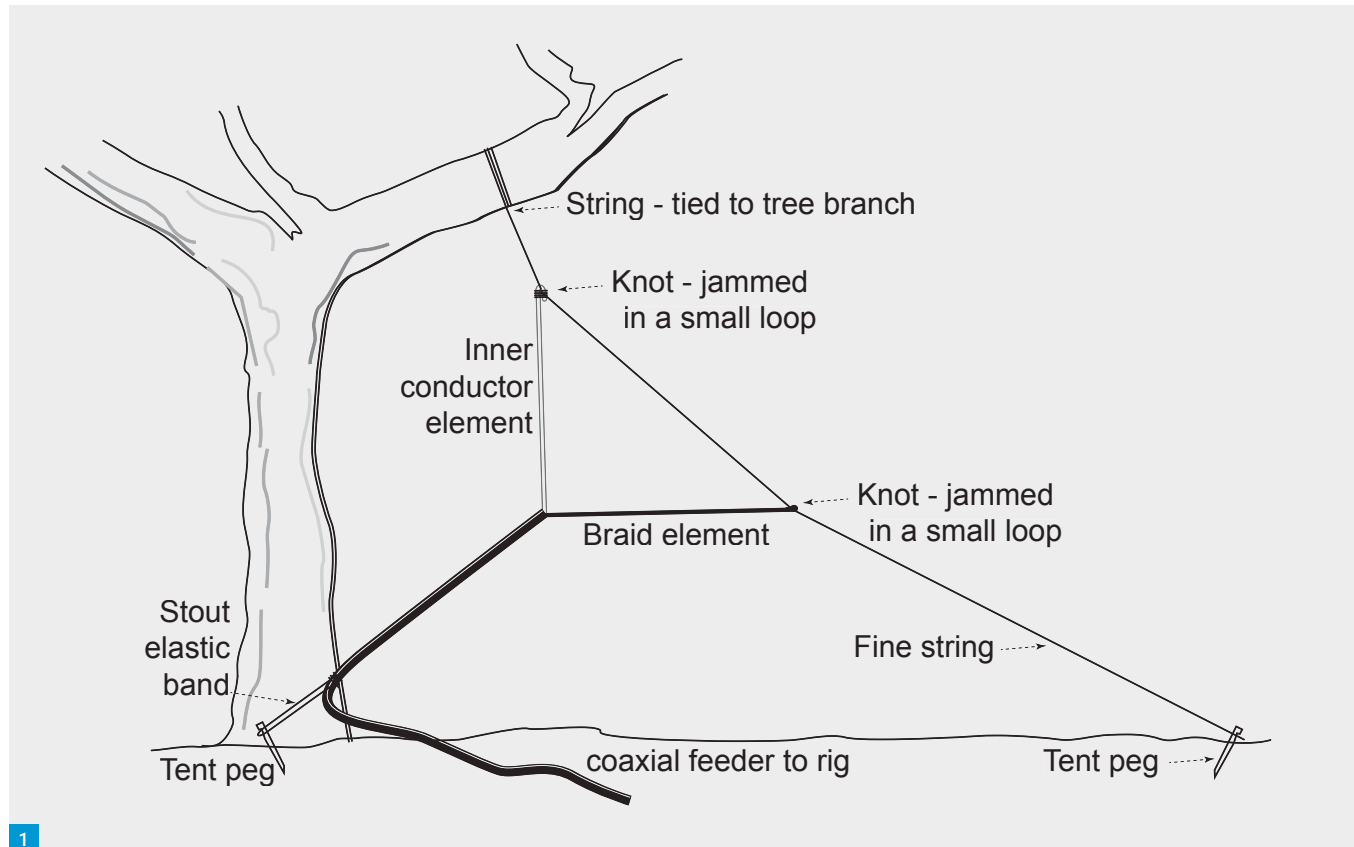

An Instant Antenna for VHF FM

Rod Angel G4ZUP describes a simple-build antenna for VHF - all you need is coax!

Rod Angel G4ZUP

practicalwireless@warnersgroup.co.uk

This antenna is quick and easy to make, works well, can be rolled up and put in a pocket, and costs almost nothing - but, for some reason, most licensed amateurs seem never to consider it.

I'm always a little surprised when I hear comments such as "Oh yes, my new rig has 4m on it, but I'm not QRV on that band yet because I have no antenna for it". My usual response is "Well, if you had an antenna, what would you use to connect it to your radio?" The answer, of course, is always "Coaxial cable" ... and typically this is followed by "I have a load of that; just no antenna".

In fact, if you have enough 50Ω coaxial feeder cable, you have almost everything you need to make an effective antenna for the FM portion of any of our VHF bands. The version described here is for the 4m band, but I have used this same basic design, scaled for each of the amateur bands from 10m to 70cm; and also for some non-amateur frequencies. It is essentially a narrow-band device which, for our purposes here, is a good thing; especially on 4m.

General Form

This antenna is technically a quarter-wave vertical, with a single ground-plane radial. The electrical length of each element is one quarter wavelength at the frequency of operation, and it works just like any other Marconi antenna.

Designs of this general form usually have more of a ground plane, made either with several radials, or with some sort of continuous planar surface; but the single radial of this design works well enough and, in practice, still produces a polar pattern that is approximately omnidirectional.

No connector is needed at the antenna end of the feeder, because the antenna itself is simply a continuation of the feeder cable. This helps to minimise losses.

The antenna support hardware consists of a piece of string, an elastic band, and two tent pegs.

You'll also need a convenient tree, house, shed, mast, or something else with some height; but this can be almost any vertical structure that you happen to have in the operating area. **Fig. 1** shows the general arrangement.

Design Calculations

Happily, there are not too many of these, and they are certainly not rocket science!

Element lengths: Firstly, we need to know what length to make the antenna elements. We start by finding the free-space quarter wavelength:

$$\text{free-space } \lambda/4 \text{ (cm)} = 7500 / \text{frequency (MHz)}$$

Then we multiply that by the velocity factor of the element conductors to get the in-wire quarter wavelength. In practice, a value of 0.95 is usually about right for this.

Note that, although the velocity factor of the coaxial cable is likely to be much lower (typically 0.66), opening up the cable and separating the conductors changes the velocity factor of those sections that will form the radiating elements of our antenna. So, for a frequency of 70.425MHz, the calculation becomes:

$$\text{in-wire } \lambda/4 = 0.95 \times 7500 / 70.425 = 101.2 \text{ cm}$$

This is the length required from the point where the coax opens out to the tip of the finished antenna elements.

If we initially cut the elements a cm or two longer, we should have enough metal to make little suspension loops at the end of each element - but the finished product needs to be as close

Sign up to our FREE email newsletter at www.radioenthusiast.co.uk



2



3



4

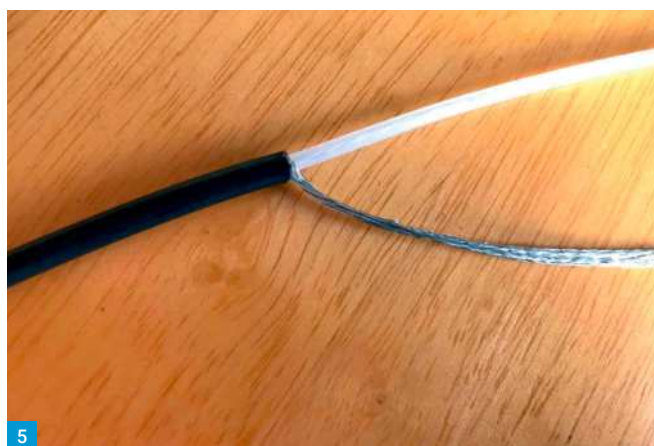

5

as possible to the calculated length. With care, it should be possible to get them within a mm or two.

String: Next we need to work out the distance between the two knots in the string. That Greek chap from school geometry lessons [1] tells us this will be:

$$1.414 \times \text{element length}$$

So, for our 70.425MHz elements, this calculation becomes:

$$1.414 \times 101.2 = 143.1 \text{ cm}$$

Most types of string are at least a bit stretchy, and this is the distance between the knots when the string is pulled tight. For the 4m antenna, a tolerance of $\pm 5\text{mm}$ in knot spacing is more than good enough.

That's the design done. Now we just have to make it.

Construction

String: Construction starts with the string. Something reasonably fine will be needed for the thinner coaxial feeder cables (RG58, mini8, etc). Ordinary parcel string would do, but one of the heavier kite-flying lines might be better. A piece 5m to 10m long – nothing conductive, of course – will be suitable for many sites. If a longer length is needed, extra bits can always be tied on later. This will not affect performance, but antenna sitting might.

Fig. 1: General arrangement of antenna.

Fig. 2: Concertina the braid to make a large loose tube. **Fig. 3: Use a spike to gently open a hole in the braid...** **Fig. 4: ...until the inner conductor can be pulled out.** **Fig. 5: Gently stroke and pull the braid to make a close-weave wire element.** **Fig. 6: Rig the antenna in an L-shape.** **Fig. 7: And the proof of the pudding ...**

Tie a few knots on top of each other to make a significant lump a couple of metres in from one end of the string. Measure the knot spacing, and start tying the second knot. Check the spacing with the string under tension, and adjust this as necessary as the second knot is built up.

With both knots complete, check the spacing again, and tweak if necessary. If using nylon string (or any other polymer), heat-seal both ends.

Coaxial cable: Select an adequate length of your chosen 50 Ω coaxial feeder and ensure that a suitable connector for your radio is fitted on one end. At the other end, remove the outer plastic sheath for a length that is a couple of cm more than your element length.

Then, concertina the braid until a large bulge is present at the bottom of the stripped section (see photo, **Fig. 2**).

Using a spike, gently open a hole in the braid until the inner conductor can be eased out. Try



6

not to break the strands of the braid. (see photos, **Figs 3 and 4**)

I would recommend wearing leather gloves (or something similar) for this next bit, because it's quite painful if the spikey ends of copper wire come into contact with bare fingers. Once the two elements are separated, gently stroke and pull the braid to collapse the tube down to a close-weave wire element, which will now be a little longer than the element formed from the coax inner, **Fig. 5**. Trim the collapsed-braid element to the same length as the inner-conductor element.

Now, with reference back to the calculated element lengths, tin a cm or two at the end of each element. Form small loops – just big enough to pass the string through – in each of the tinned sections, making sure that the distance from



7

the coax opening point to the top of each loop is equal to the calculated element length. When these distances are correct, fix each loop with a solder joint. Allow to cool, and then clean with a suitable solvent. (I use isopropyl alcohol.)

Rigging

With construction complete, it's time to rig the antenna.

Thread the prepared string through the antenna element loops so that the knots are inside the wire loops. Make a further loop at the bottom end of the string and peg this to the ground.

Next, secure the top end of the string to your chosen tree/mast/building, with sufficient tension in the string to hold everything in a more-or-less straight line.

Finally, locate a point on the coaxial feeder from where the antenna can be gently but firmly pulled into an L-shape, with the inner-conductor element vertical and the braid element horizontal. Peg this point on the feeder to the ground, using a stout elastic band to maintain tension, and thereby to keep the L-shape, **Fig. 6**.

Functional Test

With the antenna rigged as described, connect

your radio via a suitable VSWR meter and have a listen on 70.425MHz. If nothing is heard, select Low Power and apply some RF. The VSWR should be very close to the ideal 1:1. If it is, progressively work up to High Power, and check that the VSWR is still indicating a low value. It should be possible to run this antenna with a VSWR of <1.5:1 – but if the meter shows anything <2:1 at full power, I personally would not fiddle with it any further, **Fig. 7**. Perfectionists may wish to carry out VNA sweeps, and to trim the elements for a VSWR of <1.05:1, but in practice this will not make any noticeable difference to the communications performance over the FM portion of the 4m band.

Operation

This antenna is very easy to use for portable operation, and is surprisingly effective, given its simplicity. However, do bear in mind the obvious safety considerations: Don't allow anyone to touch the RF 'hot' bits (especially the element ends); and don't sit too close to it while transmitting. If in doubt, use the RSGB/Ofcom tool [2] to estimate a safe separation distance.

One final caution: This is not really an antenna to be left out in the rain, because water will wick

up the braid and spoil the coaxial feeder. If you really must leave it out in all weathers, then replace the braid leg with an element formed from a second length of coax inner conductor; and seal the separation point with hot-melt glue, self-amalgamating tape, or something similar.

Conclusion

The split coax quarter-wave vertical must be one of the world's easiest antennas, both to make and to use. It may not bear close theoretical scrutiny, but in practice it works pleasingly well.

Using a loft-mounted version, fed with 20W of NBFM, I exchanged 58 reports with a Slovenian station at a range of some 1400km. Not too shabby for a valley-floor QTH! But that's as much a story about 4m and sporadic E as it is about antennas.

References

1. Pythagoras' theorem of right-angled triangles: The square on the hypotenuse is equal to the sum of the squares on the other two sides. In this application, if the elements are taken to be of unit length, the knot separation (hypotenuse) will be $\sqrt{2}$ times element length. The specified 1.414 is a pragmatic approximation of $\sqrt{2}$.
2. <https://tinyurl.com/35fw947p>

Sign up to our FREE email newsletter at www.radioenthusiast.co.uk

Colin Redwood G6MXL
practicalwireless@warnersgroup.co.uk

Generally good weather, albeit with a rather cold northerly wind in part, greeted those who ventured out portable for the 14th Practical Wireless 70MHz Contest on Sunday 25 September 2022. The 26 entrants made a total of 530 contacts with 97 different stations in 21 different squares, Fig. 1.

Low Power Section Winner

Regular entrant **Steve Clements GW1YBB/P** operated from the 800m summit of Pen-Y-Gadair in the Black Mountains in IO81KW. He is again the winner of the low power section. He used a Yaesu FT-817 with a UT5JCW transverter running 8W to a homebrew 6-element Yagi antenna.

Open Section Winner

Dave Butler G4ASR is the winner of the high-power section. He used an Icom IC-7300 with a solid-state power amplifier feeding a 7-el DK7ZB Yagi antenna. Dave, who used to write the PW VHF column some years ago, completed a random SSB meteor scatter contact with OV3T in JO46CM at 882km. He started with 15-second periods, but immediately heard the Danish station and so reverted to conventional sequencing. As far as I recall this is the first time that a meteor scatter contact has successfully been completed in the contest.

Full details of the results can be found in the tables in this article. As usual certificates will be sent to all the leading stations and leaders in each square.

Weather

Steve Clements GW1YBB/P suffered from a cold wind from the North/Northwest, which was blowing cold air into his tent doorway. Steve had to keep the doorway partly open in order to turn the antenna. He needed to wear two pairs of walking socks and use his Buffalo shirt as a leg blanket and wore latex gloves to keep his fingers usable, Fig. 2!

Conditions

Dave Shaw M5DWI operating G5TO/P on behalf of the Sheffield and District Wireless Society thought that conditions were, "Mediocre at the start, worsened through contest, in short, disappointing". **Martyn Wright G4RLF/P** (from SAGITS) in Dorset could hear the Angus beacon at 52, but felt that his 10W wasn't very successful to the North this year, Fig. 3. Steve Clements GW1YBB/P thought, "radio conditions were nothing special, EU activity extremely low, I think I got one QSO in EU". He only heard two stations from Scotland. He thought Brian GM4DIJ was "doing a valiant effort of being on for most of the contest making just five QSOs".

The 14th PW 70MHz Contest: Results 2022

Colin Redwood G6MXL presents the results of the 2022 contest.

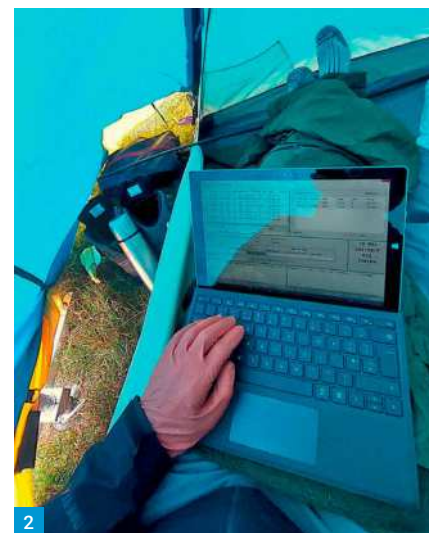
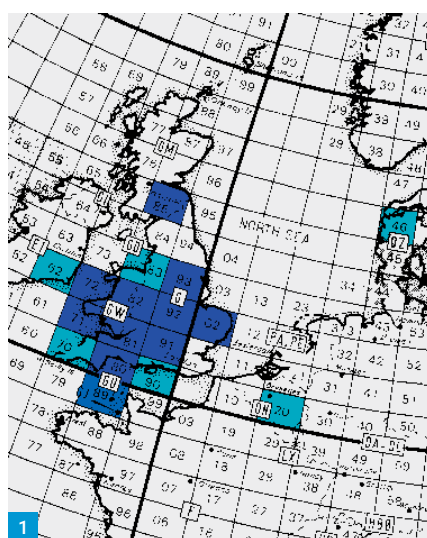

Description	Name/Team	Callsign
Low-Power Winner	Steve Clements	GW1YBB/P
Open Winner	Dave Butler	G4ASR
Leading Single Operator	Steve Clements	GW1YBB/P
Leading Multi-Operator	Pauline & Chris Kirby	G8HQW/P
Leading English Station	Dave Butler	G4ASR
Leading Welsh Station	Steve Clements	GW1YBB/P
Leading Scottish Station	Brian Howie	GM4DIJ
Leading Channel Islands Station	Chris Rees	G3TUX

Table 1: Leading stations

Ken Easty G3LVP thought, "Conditions were no better than average and activity not as good as some previous events". **Andy Digby GW0JLX** felt he had a "very poor showing in this year's contest with only 15 contacts and eight squares. For some reason I really struggled – not quite sure why at the moment".

Activity

Ken Easty G3LVP was sure that the results will show that there were many stations active that he didn't work or even hear despite spending much time turning his beam and putting out CQ calls on SSB and CW. He was surprised that some weak stations that he worked seemed to have difficulty in receiving his 160W. He could only assume that they either were suffering from local noise or had poor sensitivity receivers and possibly temporary antennas. "It seems that as time goes on it's becoming more difficult to work stations who I know are on but I never hear".

He wonders, "whether this is because beams available today have sharper beamwidth unlike the 4-element J Beams of old, which you hardly needed to turn?"

Noise

Chris Rees GU3TUX on Alderney says, "4m is always affected by man-made noise. It was not too bad until the last hour when a band-wide noise of a sound like telephone directories being torn up to an accompaniment of ignition interference drove me to QSY to 40m to snatch a couple of contacts in the concurrent FISTS ladder session. Never mind, it was well worth doing and I hope everyone else enjoyed themselves."

Signal Complaints

Two stations complained about each other's signals. Neither station appeared to have carried out a full range of checks to ensure that the problems were not due to receiver overload.

Read more radio news and reviews at www.radioenthusiast.co.uk/news



3



4

Pos	Callsign	Name	Score	QSOs	Squs	Sngl op	Loc	Ant.	asl,m	Tx/Rx
1	GW1YBB/P	Steven Clements	1134	63	18	S	I081	6-ele homebrew	800	Yaesu FT-817 + UT5JCW
2	G4RLF/P	SADGITS	455	35	13		I080	5-ele	270	Icom IC-7300
3	G8FMC/P	Dave Keston	187	17	11	S	I091	3-ele LFA	111	Yaesu FTdx10
4	G3UGF/P	Richard J. Constantine	77	11	7	S	I093	4-ele Yagi	403	Icom IC-7300
5	G8ZAX	Rob Rees	45	9	5	S	I091	4-ele LFA	87	Elecraft K3s+ TVTR
6	M7PAT	Pat Davies	20	4	5	S	I093	Moxon	67	Icom IC-7100
6	2E0RWR	William Rees	20	5	4	S	I091	Moxon	87	Yaesu FT-817 + MM Transverter
8	G0E1Y	Simon Pryce	15	5	3	S	I082	'supadupa Moxon beam' HB	70	Kenwood TS-2000 + Ukrainian TVTR
8	G4FKI/P	Dave Thorpe	15	5	3	S	I081	quarter wave ground plane	203	Icom IC-7100

Table 2: PW 70MHz low power results table

Pos	Callsign	Name	Score	QSOs	Squs	Sngl op	Loc	Ant.	asl,m	Tx/Rx
1	G4ASR	David Butler (Hereford ARS)	1083	57	19	S	I081	7-el DK7ZB Yagi	25	Icom IC-7300 + SSPA
2	G8HQW/P	Pauline and Chris Kirby	630	42	15		I094	7-ele beam	274	Icom IC-7300 + Gemini amplifier
3	G2HX/P	Gloucester Amateur Radio & Electronics Society	600	40	15		I081	5-ele Quad Yagi	273	Icom IC-7300 + Gemini amp.
4	G3WAG/P	Derek Gillett	396	36	11	S	I082	5-ele DK7ZB	248	Icom IC-7300
5	G0LGS/P	Hereford Amateur Radio Association	372	31	12	S	I091	5-ele PowAbeam	260	Icom IC-7300
6	G8LED/P	Northampton Radio Club	325	25	13	S	I092	6-ele LFA at 12m	135	Icom IC-7300
7	G3LVP	Ken Eastty	300	25	12	S	I081	6-ele Yagi	30	Kenwood TS-850 HB TVTR 1x 4CX250B PA
8	G5TO/P	Dave Shaw	261	29	9	S	I093	4-ele HB	310	Icom IC-7100
9	G3RIR	Neil Ackerley	136	17	8	S	I092	5-ele	12	Yaesu FTdx10
10	GW0JLX/P	Andy Digby	120	15	8	S	I072	6-ele Yagi	400	Icom IC-7100
11	G0NZI	Carl Peake	104	13	8	S	I092	2-ele Moxon	94	Yaesu FT-847
12	MC0IBI/P	Taff Vale ARC	84	12	7		I081	4-ele LFA beam	153	Icom IC-7100
13	GU3TUX	Chris Rees	70	10	7	S	IN89	HB9CV	65	Kenwood TS-890S
14	GW4JQP	Peter Harston	45	9	5	S	I071	HB9CV	52	Icom IC-7300
15	MW0XTK	Phillip Hoath	35	7	5	S	I072	Moxon	213	Icom IC-7300
16	GM4DIJ	Brian Howie	20	5	4	S	I085	6-ele Yagi	69	Icom IC-7300 + TE Systems Linear
17	G8RF	Frank Raby	9	3	3	S	I082	Collinear	140	Kenwood TS-590 + Spectrum TVTR

Table 3: PW 70MHz open section results table

Sign up to our FREE email newsletter at www.radioenthusiast.co.uk

Square	Name	Call	No. entries
IN89	Chris Rees	GU3TUX	1
IO71	Peter Harston	GW4JQP	1
IO72	Andy Digby	GW0JLX/P	2
IO80	SADGITS	G4RLF/P	1
IO81	Steven Clements	GW1YBB/P	6
IO82	Derek Gillett	G3WAG/P	3
IO85	Brian Howie	GM4DIJ	1
IO91	Hereford ARS	G0LGS/P	4
IO92	Northampton RC	G8LED/P	3
IO93	Dave Shaw	G5TO/P	3
IO94	Pauline & Chris Kirby	G8HQW/P	1

Table 4: Leading stations in each square.

Fig. 1: Map showing locator squares of stations that entered (in dark blue) and other stations worked (light blue). Fig. 2: Steve Clements GW1YBB/P trying to stay warm. Fig. 3: Martyn G4RLF/P. Fig. 4: The new site used by Dave Keston G8FMC/P. Fig. 5: The team from Gloucester Amateur Radio & Electronics Society G2HX/P seen assembling their antenna. Fig. 6: Derek Gillett's set-up at G3WAG/P. Fig. 7: Andy Digby GW0JLX/P in Wales.

No other entrants made complaints about either station.

NewSite

Dave Keston G8FMC/P tried out a new site, **Fig. 4**. Although more of a plateau rather than a hill, it had a good take-off and was close to his home, which was useful as he was able to return home to pick up a forgotten N-type barrel connector. He found the biggest advantage was a dramatic reduction in noise compared to his home QTH, down by a minimum of 8dB in one direction and 12 to 15dB in other directions. The new location enabled him to run a second pre-amp without the need of the excellent noise reduction on his FTdx10 transceiver.

Logging

Logging accuracy was generally good with just a few points deducted during adjudication. One station lost several points due to mis-keying locators, including mistaking the letter I for the number 1.

2023

The 15th PW 70MHz Contest is provisionally booked for 24 September 2023. I am expecting the rules to appear in the September 2023 issue due in the shops mid-August 2023.

Congratulations & Thanks

Congratulations to the 2022 winners and on behalf of all entrants a big "Thank You" to all stations that participated. **PW**

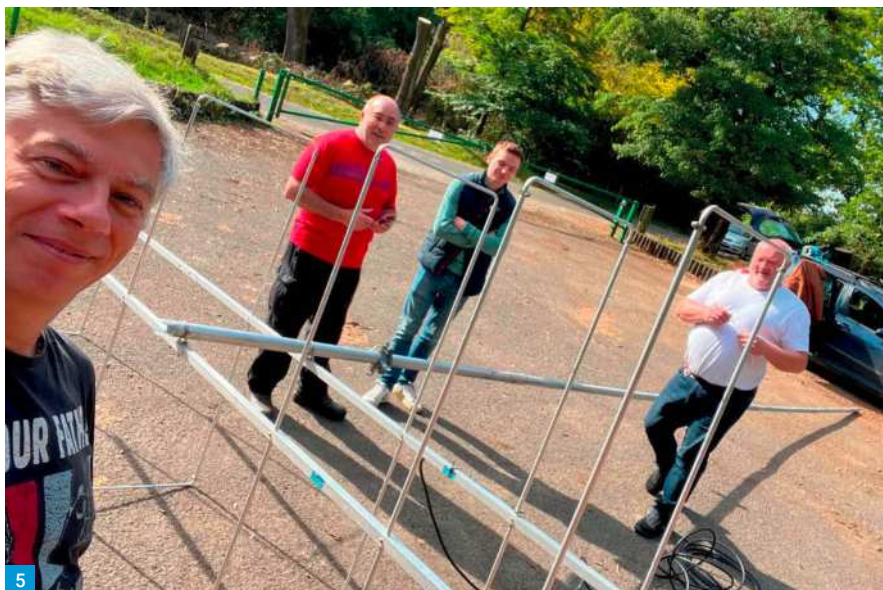

Read more radio news and reviews at www.radioenthusiast.co.uk/news

Don Field G3XTT

practicalwireless@warnersgroup.co.uk

Short-wave apparatus is generally characterised by elaborate metal chassis, screens and complicated layouts, for which reason many experimenters are not taking advantage of the enjoyment of short-wave work, thinking that it is complicated or beyond their ability. Actually, of course, this impression is erroneous, and apart from the fact that tuning is slightly more critical and thus has to be carried out more carefully, there is nothing out of the ordinary in short-wave work.

To prove that efficient short-wave apparatus may be made, even by the beginner; without elaborate screening or similar devices, the Short-wave Three has been designed and is illustrated and described here. It will be seen that the set is compact (the chassis is only 8in. by 7in. in size); the layout is quite ordinary, and the receiver is no more difficult to build than a standard broadcast receiver. Short-wave components must, of course, be used as the performance of the short-wave signals is a little different from the normal currents experienced on broadcast frequencies. Insulation is one of the most important properties in short-wave work, and accordingly only the best quality coil and valve holders are specified. Ceramic insulation is employed in all but one of these, the remaining six-pin coil holder not at the moment being available in this material. A special high-efficiency material is, nevertheless, used in the Eddystone component specified, and this will be found perfectly satisfactory.

The Circuit

The remaining components, namely tuning condensers and choke; are also of the special short-wave type, whilst fixed resistances, condensers and the transformer are of standard type. The circuit will show that the arrangement of H.F. detector and output stages is employed, transformer coupling being used in the tuned circuits. On the aerial side an air-dielectric pre-set condenser will take care of aerial loading, and a standard four-pin plug-in coil is used to feed the grid circuit of the H.F. pentode valve. This is of the "straight" type, with a floating H.T. lead for the screen so that maximum efficiency may be obtained by using the most suitable H.T. voltage on the screen. The next coil unit is of the six-pin type, having primary and reaction windings. The reaction circuit is arranged with the moving vanes of the reaction condenser

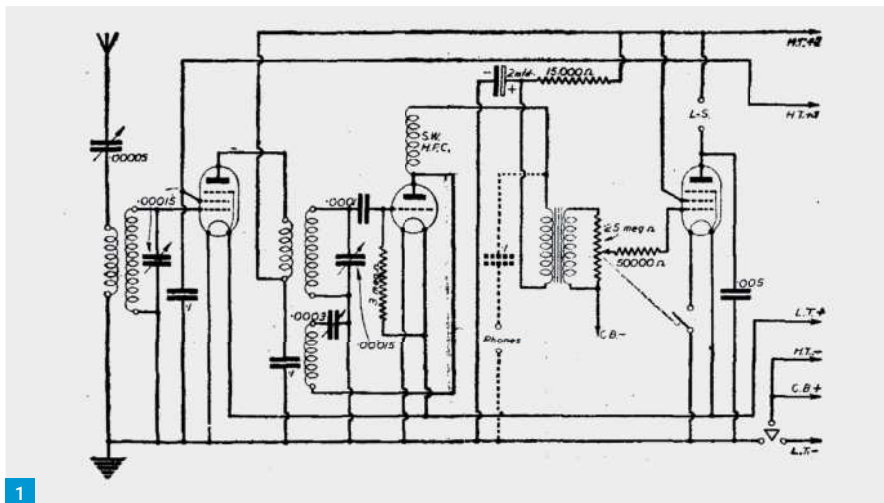

The Short-wave Three (PW September 1940)

This project featured a simple-to-build three-valve receiver using components available during wartime.

earthed direct, thus avoiding hand-capacity effects, and standard values of grid leak and condenser are employed. The detector anode circuit is decoupled and at this point it will be seen that an alternative 'phone circuit is provided. When searching for weak stations, it is often found that headphones are very desirable, but if connected in the output stage distress is caused when a loud signal is passed. By cutting out the output stage, however, this trouble may be overcome, and when a suitable signal is tuned-in it may be transferred to the loudspeaker, or made louder in the 'phones by addition of the output stage.

As an economy step in this connection the L.F. volume control is specified to include an on/off switch, and this is wired in the filament circuit of the output valve. Thus, when the volume is turned to minimum the switch is brought into circuit and the output stage is rendered inoperative, when the 'phones may be connected in the detector stage. The remaining valves are, of course, switched off by the usual on/off switch. The 'phones are filter-fed, using the L.F. transformer primary as an L.F. choke. An H.F. stopper is included in the output grid circuit to ensure stable working, whilst a

by-pass condenser from the anode of the output valve will help to prevent "head capacity" effects.

Construction

The chassis will have to be home-made, ordinary plywood serving quite well. The size, as already mentioned, is 8in. by 7in. with runners 2 1/4in. deep. A panel may also be cut, although in the original model brackets were used for mounting the parts in order that a more detailed illustration could be obtained without obscuring any of the parts or wiring. Furthermore, it will be seen from the illustration on our cover that simple dials have been fitted: For short-wave work it is generally desirable to use slow-motion drives, and there is a variety of these from which to choose.

The drive will necessitate that the condensers are mounted on brackets, but these will have to be placed back from the front edge of the chassis in order to accommodate the drive, and this may mean that the two coil holders will also have to be pushed more to the rear. There is, however, no other top of chassis component which will prevent this and there is thus sufficient latitude for any type of drive to suit individual preference.

This project appeared in the September 1940 issue of Practical Wireless. Although PW continued publication during the war years, this was the first issue to reflect a move to monthly publication (and an 'increase' in price from 4d a week to 6d a month!). See this month's Keylines for more.



Sign up to our FREE email newsletter at www.radioenthusiast.co.uk



2

Fig. 1: For those who like to examine the theoretical circuit, this diagram will give them all the details they require. Note the alternative 'phone circuit. Fig. 2: A rear view of the assembled receiver showing the aerial series condenser located in an easily accessible spot. Fig. 3: Top of chassis component placement. Fig. 4: Under chassis wiring and component placement. Fig. 5: Plan view of the underside of the chassis, showing the exact location of parts and the associated wiring.

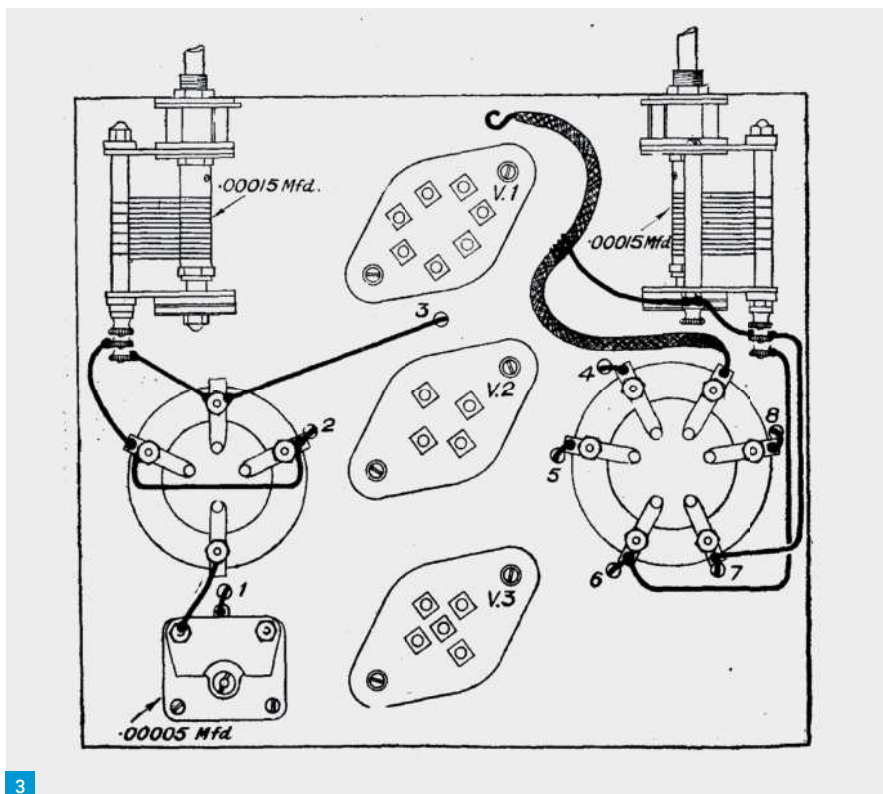

3

If a metal panel is used to provide screening, no precautions need be taken regarding insulation of the panel-mounted components. The moving vanes of both tuning and the reaction condenser are intended to be earthed and thus they could be clamped to the panel. The push-pull switch is also on the earth-line and thus this is in order. The volume control which is specified has a "dead" spindle and therefore this is also in order. If, however, any departure is made from the specification this point must be watched as certain volume controls are supplied in which the spindle is "live" to the moving arm, and this will mean that if such a component is used and mounted on a metal panel without insulating bushes the grid of the output valve will be earthed and no signals will be obtained.

Holes for the three valveholders are drilled on the centre line, 1in. diameter holes being used for the four- and five-pin holders, and a 1¼in. hole for the seven-pin holder. The two coil holders are next screwed down in their respective positions, and on the underside the choke and transformer are screwed into position; after which wiring may be commenced. The wiring diagram is drawn to scale and therefore exact positions may be marked off from this.

Some constructors prefer to assemble a complete receiver before undertaking wiring, but this is not always the best plan owing to the difficulty of obtaining access to certain parts. For instance, the contacts on the switch section of the combined volume control and switch will be found very close to the transformer casing, and if the control is mounted before being wired it may be found

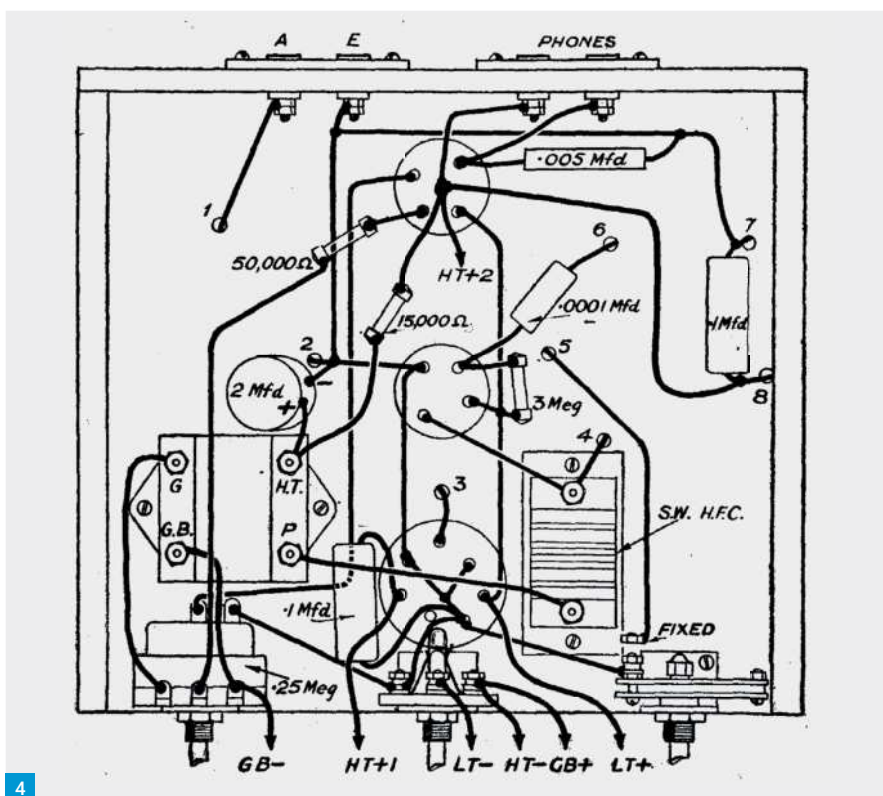

4

impossible to solder the leads to the switch. They may, of course, be soldered on to the switch before this is mounted or alternatively the transformer may be left off until the wiring to the switch has been completed.

Each constructor will, no doubt, have his own ideas as to wiring, but when difficulty is experienced due to inaccessibility, it is not a difficult matter to remove a part to facilitate the work. However, in this particular receiver, it will

40-50 metre Band

Metres	
41.32 Lisbon (Portugal)	CSW8
41.32 B.B.C.	GSU
41.34 Tokio (Japan)	JBW
41.49 B.B.C.	GSW
44.94 Radio Nations (Switzerland)	HBQ
48.47 Schenectady (U.S.A.)	WGEO
48.86 Pittsburgh (U.S.A.)	WPIT
49.10 B.B.C.	GSL
49.59 B.B.C.	GSA
49.67 Boston (U.S.A.)	WRUL
49.75 Moscow (U.S.S.R.)	RW96
50.00 Moscow (U.S.S.R.)	RNE

30-40 metre Band

Metres	
30.96 B.B.C.	GRX
31.25 Moscow (U.S.S.R.)	RAL
31.25 B.B.C.	GRY
31.28 Sydney (Australia)	VK2ME
31.35 Pittsburgh (U.S.A.)	WPIT
31.41 Schenectady (U.S.A.)	WGEA
31.48 Tokio (Japan)	JZI
31.48 Schenectady (U.S.A.)	WGEO
31.70 Ankara (Turkey)	TAP
32.12 Radio Nations (Switzerland)	HBL:
39.89 Moscow (U.S.S.R.)	RKI

20-30 metre Band

Metres	
20.64 Radio Nations (Switzerland)	HBJ
25.00 Moscow (U.S.S.R.)	RNE
25.21 Clumgiding (China)	XGOY
25.27 Pittsburgh (U.S.A.)	WPIT
25.29 B.B.C.	GSE
25.38 B.B.C.	GSM
25.45 Boston (U.S.A.)	WRUL
25.53 B.B.C.	GSD
25.58 Boston (U.S.A.)	WRUL
26.31 Radio Nations (Switzerland)	HBO

16-20 metre Band

Metres	
16.85 B.B.C.	GSV
16.86 B.B.C.	GSG
16.87 Bound Brook (U.S.A.)	WNBI
16.87 Pittsburgh (U.S.A.)	WPIT
19.47 Moscow (U.S.S.R.)	RW96
19.57 Schenectady (U.S.A.)	WGEA
19.60 B.B.C.	GSP
19.66 B.B.C.	GSI
19.67 Boston (U.S.A.)	WRUL
19.72 Pittsburgh (U.S.A.)	WPIT
19.74 Ankara (Turkey)	TAQ
19.74 Chungking (China)	XGOX
19.76 B.B.C.	GSO
19.76 Moscow (U.S.S.R.)	RW96
19.82 B.B.C.	GSF
19.83 Boston (U.S.A.)	WRUL
19.95 Moscow (U.S.S.R.)	RKI

be found that it is preferable to leave all panel parts until the last possible moment, wiring valveholders, fixed resistors and condensers, as they are needed, and finally connecting up the tuning condensers, volume control, reaction condenser and switch. Work through the circuit, marking off all leads as they are put in.

Testing the Receiver

When the set is completed there are two alternative courses available. Firstly, batteries may be connected, without the valves plugged in, and all voltages carefully measured. If everything is found in order, then valves may be inserted and current tests taken at each point.

Then the aerial may be connected and signals

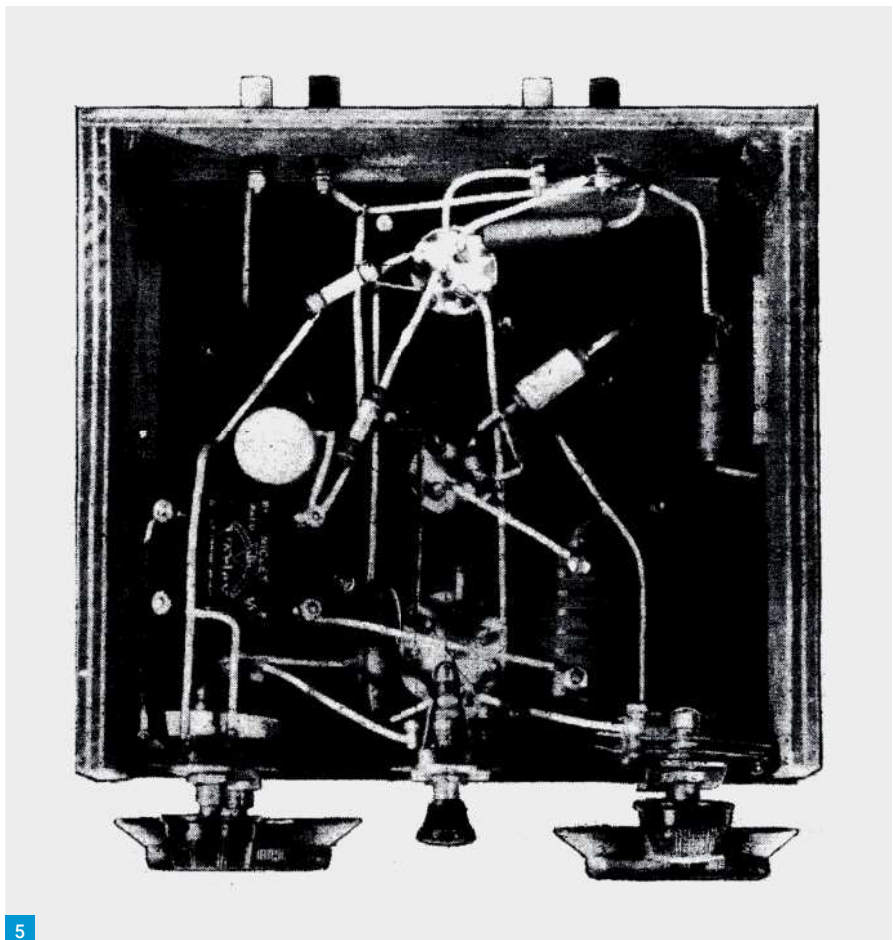

sought for. The other method is merely to check that there is no H.T.-L.T. short-circuit, and then to insert the valves and commence by signal-searching. There should be no difficulty in this; using the 'phones in the detector stage for preference, and with the aerial pre-set condenser adjusted so that the vanes are completely intermeshed.

Both condenser dials should be turned together, keeping them balanced as nearly as possible. The aerial condenser will be found slightly flatter in tuning than the intervalve condenser, and a search round the dial on the 20-metre band should enable you to locate some commercial transmitters: In the event of your being unable to find any signal, the reaction control should be advanced so that there is a rushing noise in the 'phones. Stop just short of the point where a whistle or howl is heard; and then search through the dial. If this is unproductive of signals it would tend to indicate some fault in the wiring, although it must be remembered that on certain bands signals cannot be heard at certain times of the day or night. As a guide we list on the next page some of the station which you should hear on the popular bands, but owing to the present conditions arising from the war, it may be found that these are not giving scheduled broadcasts. **PW**

List Of Components for Short-Wave Three

- Two .00015 mfd. tuning condensers, Short-wave "Special," Cat. No. 2,043 (J.B.).
- One .0003 mfd. reaction condenser, "Dilecon." Cat. No. 2,094 (J.B.).
- Three ceramic valveholders (Eddystone):
- One 4-pin, type 1,073.
- One 5-pin, type 1,074.
- One 7-pin, type 1,075.
- One 4-pin coil holder, type 949 (Eddystone).
- One 6-pin coil holder, type 969 (Eddystone).
- One 250,000-ohm volume control with switch, type J (Dubilier).
- One L.F. transformer, "Niclet" 5/1 (Varley).
- Three two-socket terminal strips, A, E and 'phones. (See text). (Bulgin).
- One H.F. choke, type H.F.3 (three-point) (Bulgin).
- One push-pull switch, type S.36 (Bulgin).
- Five fixed condensers (Dubilier):
- One .0001 mfd, type 4601/S.
- Two .1 mfd, type 4603/S
- One .005 mfd, type 4601/S.
- One 2 mfd, type 3016.
- (One .1 mfd, type 4603/S - see text).
- Three fixed resistances (Bulgin):
- One 15,000 ohm ¼-watt type.
- One 30,000-ohm ¼-watt type.
- One 3-megohm ¼-watt type.
- One pre-set condenser, 50 mmfd. Cat. No. 2,144 (J.B.)
- One Z21, one L210, one PT2 valve (Osram).
- One pair 4,000-ohm headphones (Ericsson).
- Set of 4- and 6-pin plug-in coils (Eddystone).
- Chassis, wire, screws, etc.

TechnoFix.uk



USB
RTL-SDR
Sticks
and
accessories



Connectors for
audio, RF and
power



Microphones,
cables and
accessories



USB CAT and
programming
cables



Visit us on-line
for all this
and more!



technofix.uk
www.technofix.co.uk
mail@technofix.uk

"Secret" Frequencies for SDR Fun Worldwide Broadcast and Utility Radio Stations

Up-to-date frequencies, schedules and digital data codes for 2023!

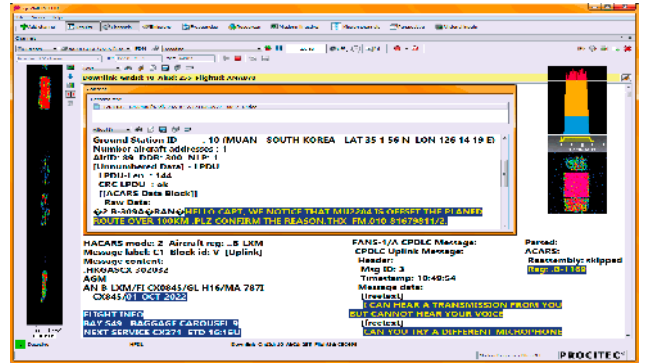

2023 Shortwave Frequency Guide - EUR 45 = £ 39

350 pages, 13,300 entries with all broadcast and professional utility stations worldwide. Latest schedules for 2023. Clearly arranged and really user-friendly. 27th edition!

2023 Super Frequency List CD - EUR 30 = £ 26

4,000 shortwave broadcast frequencies, 9,300 frequencies of utility radio stations, plus 24,000 formerly active frequencies. 1000 fascinating new digital data decoder screenshots. 29th edition!

2023/2024 Guide to Utility Radio Stations - EUR 55 = £ 48

plus Supplement January 2024 with 300+ new frequencies!

550+16 pages, 9,300 frequencies and 240 digital data / SDR screenshots. Frequencies, stations, call signs, codes, abbreviations, meteo/NAVTEX/press schedules, and much more. 32nd edition!

Special package prices available:

Safe 15 EUR: SWFG + UTG = 85 EUR = £ 74. SWFG + CD = 60 EUR = £ 52.

Utility Stations Guide + Frequency List CD = 70 EUR = £ 61.

Safe 20 EUR: SW Freq Guide + Utility Stations Guide + CD = 110 EUR = £ 96.

Payment by Mastercard, Visa, bank, cash (EUR only). No cheques! Worldwide postage is £ 8 per kg. See our website and free 2023 catalogue for more products, detailed descriptions, recommendations from all over the world, and hundreds of the very latest radio monitoring screenshots. We've been leading in this field for 55 years!

Klingenfuss Publications · Hagenloher Str. 14 · 72070 Tuebingen · Germany
Fax +49 7071 600849 · Phone 62830 · info@klingenfuss.org · www.klingenfuss.org



www.sotabeams.co.uk

All items shipped from our UK factory. Prices exclude p&p.

The Carbon-6 Ultra-light Mast



£44.95

A carbon-fibre telescopic mast, ideal for lightweight end-fed wire antennas.

Extended length 6 metres

Packed length 43cm

Weight just 315g

Small enough to fit in a rucksack, tall enough to support your antenna.

A highly portable light-duty mast.

2 metre filter



2m bandpass filter £44.95

Put a stop to interference
Make more contacts!

Read more radio news and reviews at www.radioenthusiast.co.uk/news

Mike Richards G4WNC

practicalwireless@warnersgroup.co.uk

This month, I have lots to cram in, starting with some VarAC operating tips. I'll follow this with a look at some new SDR software and finish with **Simon Brown's** updated World Map.

VarAC Operating Tips

In last month's column, I supplied a detailed, step-by-step installation process to set you up using this excellent HF chat mode. Hopefully, you will have made a few contacts and familiarised yourself with the mode. I've been using VarAC and receiving regular updates from **Victor G3JNB**, a very keen new user. As with all new modes, the initial problem is getting enough active users. Things are improving, but we need more operators, so why not join us?

VarAC Beacons

One special feature of VarAC is its beacon mode. When activated, this automatically transmits your callsign every 15 minutes and is a simple way to advertise that you're available. At the receiving stations, all received beacons are displayed in the Last Heard Beacons panel, along with details of the bandwidth (normally 500Hz) and the received signal level. This is a helpful indicator of stations that are receivable on the current band. Sending beacons also provides a great way to see how well your signal propagates. In its default configuration, VarAC automatically uploads all valid receptions to the PSKReporter website. That means everyone who hears you will automatically send a report to PSKReporter. You can then use the PSK REP MAP button in the bottom right of the VarAC main screen to view a map showing the stations that have received your beacon, along with your signal report, **Fig. 1**. New users often miss the PSK button, but it's a handy tool for checking your signal.

The other helpful feature associated with beacons is the facility to Ping any received beacon station. To use this, hover your mouse over the desired beacon in the last heard list, right-click and choose Ping (get report). This will initiate a mini-QSO with that station to gather signal reports for both directions and close the link.

This is useful for checking that you can reach a station. Pings are also helpful for new users as they provide reassurance that your station is working correctly, and you should be able to make a QSO with that station. If you want more information about the station you're pinging, you can press the INFO button as soon as you get the connected message. This will trigger the remote station to transmit the full station details automatically.

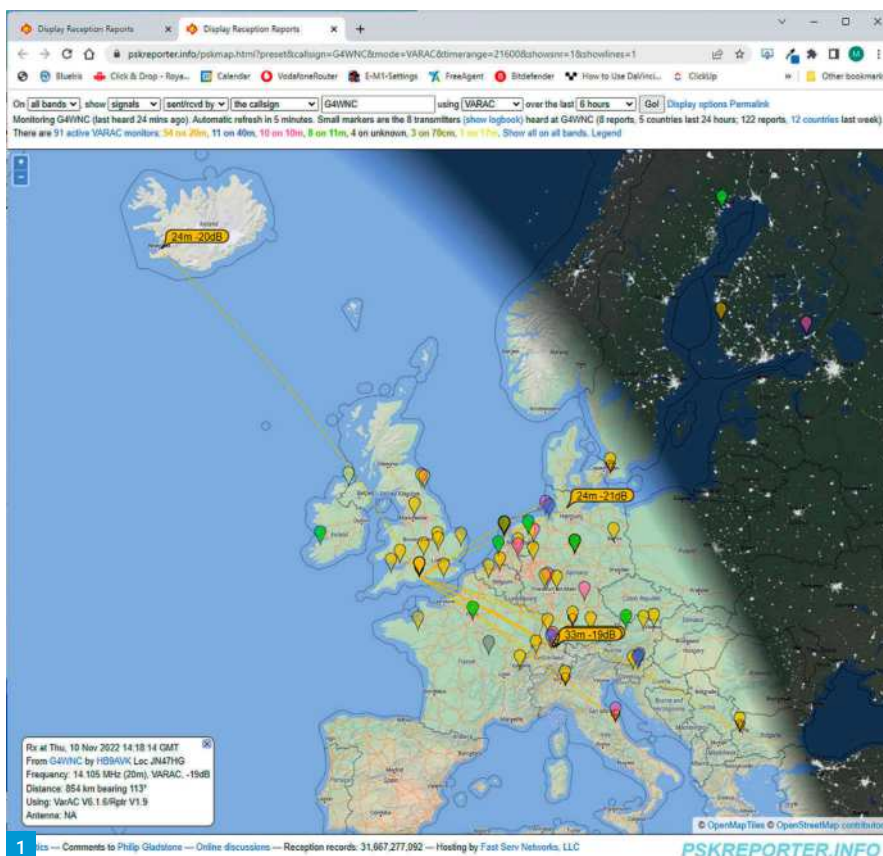

More on VarAC

Mike Richards G4WNC follows on from last month's discussion of VarAC before moving on to MagicSDR and Simon's World Map.

QSY from Calling Frequency

When I receive an incoming ping request, I usually try to connect with the station to see if they want to QSO. To initiate a call from the beacon list, you simply double-click on the selected callsign in the list. This will initiate a direct call to that station. Once connected, you can start your chat. If your chat is very short and the band is quiet, completing the QSO on the calling channel is acceptable. However, for longer QSOs, or when the band is busy, it is good practice to QSY. VarAC has a built-in process to make QSYing a simple operation.

On the right-hand side of the main window, **Fig. 2**, you will see a greyed-out text line marked QSY with up and down arrows. When you're in a QSO, these buttons become active and are used to initiate a QSY. To QSY down in 750Hz steps, press the down arrow, and a QSY confirmation message will appear on both operators' screens. If they accept the request, both stations will automatically QSY to the new frequency without breaking the connection. You can also check that the proposed frequency is clear before QSYing.

To do that, right-click and hold while the mouse is over the Up or Down arrow. This will temporarily retune the rig to the new frequency without breaking the connection. If the frequency is clear, you can go ahead with the full QSY request. Instead of QSYing up or down in 750Hz steps, you can use the # icon to choose your own QSY frequency.

Log Information During Chat

While VarAC is great for freeform chatting, this style of communication makes it difficult for the software to automatically extract important logging information such as city, locator, name, rig, etc. VarAC has solved this problem by using Tags. Tags are short abbreviations wrapped in angle brackets (<>) that trigger the software to send the full information, also enclosed in angle brackets. For example, to send your name you just type <NAME> in the new message box. VarAC then recovers your name from your station information and sends it like so:

<NAME: Mike>

At the receiving end, this format is recognised,

Sign up to our FREE email newsletter at www.radioenthusiast.co.uk

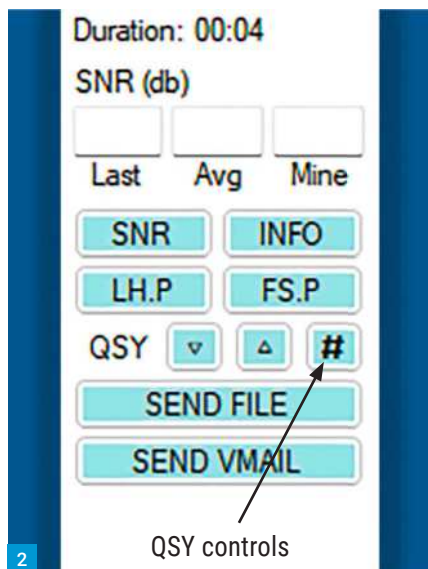

2

QSY controls

Fig. 1: VarAC PSKReporter map display.

Fig. 2: VarAC QSY panel.

Fig. 3: VarAC canned messages.

Fig. 4: MagicSDR client-server operation.

Fig. 5: MagicSDR main window.

Fig. 6: Simon's World Map.

and my name will be transferred to the log. I've shown a list of the most common tags in **Table 1**. Instead of hand-typing the tags, I've set up a couple of canned messages (memories or macros) to handle the logging information. The first message stores my name, QTH and locator like so: My details: <NAME> <QTH> <LOC>

The second canned message has the rig and antenna details like so: My station: <RIG> <ANT> <PWR>

The canned messages can be sent using the small 'Local canned message' drop-down box in the bottom right of the main screen, **Fig. 3**, or by using your computer's function keys. I have mine configured with 'My Info' on F1 and the 'Rig details' on F2. During a QSO, I normally send My Info at the beginning of the first over and add the rig details in the second over. By splitting the messages in this way, you avoid boring the other station with a long dump of information.

VarAC supports the following logging programs: N1MM, HRD Logbook, DXKeeper, AC Log, Log4OM and Swisslog. Full details for setting up logging can be found in the VarAC online manual. If your logging program is not supported, all is not lost, as VarAC creates its own log in standard ADIF format. You can use this file to import your VarAC contacts into your unsupported logging system.

Gestures

VarAC has a few enhancements that can add a bit of variety to your chats. Gestures are a bit like emoticons in social media, but there are only a few available. To use a gesture, you simply enter

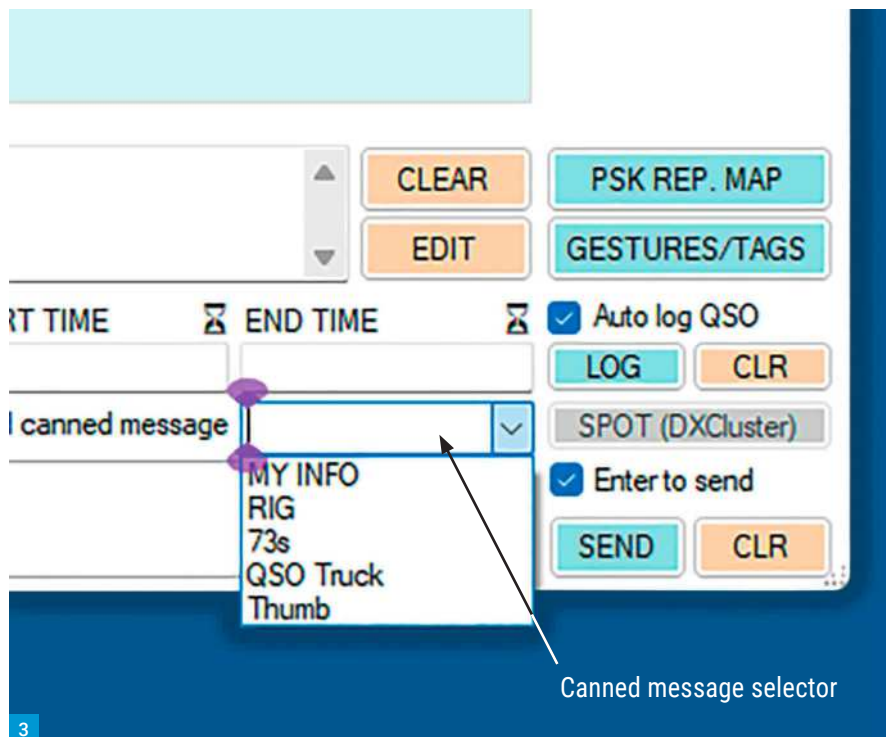

3

Canned message selector

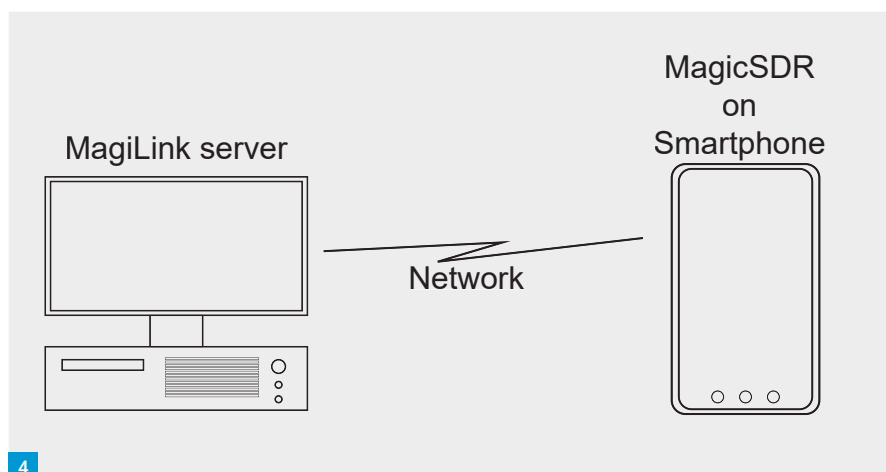

4

the trigger text into your message. For example, to add a couple of smiley faces, you type: HIHI, for thank you its: TU! To send a couple of thumbs-up icons use: LIKE! You can also use gestures to make sounds on the other station's PC. For a single ding, enter DING, whilst DISCO plays three ding sounds. This latter command is useful when trying to connect to a beacon station that's not responding to chat. In this case, you can type DISCO to attract the operator's attention. It's worth a try and might get you a QSO you would otherwise have missed.

MagicSDR

Here's a new SDR application that is being actively developed. It's available free of charge for Android, iPhone and Windows 10 & 11. The software is obtained via the following distribution systems: Apple App Store, Google

Play and Windows store. MagicSDR currently supports the following SDRs: RTL-SDR dongles, Airspy R2/Mini, Airspy HF+ series, SDRPlay and Hermes Lite (Rx only at present).

There are plans to expand the list to include HiQSDR, Flex 6000 series and soundcard-based radios. MagicSDR uses a client Server mode of operation where the receiver is connected to a computer running either of the following servers: MagicLink, rtl_tcp or Spy Server. MagicSDR then connects to the server over the network, **Fig. 4**. The exception is for RTL-SDR dongles, as these can also be used directly with your phone or tablet using a readily available OTG (On-The-Go) cable.

The MagicLink server has versions available for Windows, Linux x64 and Linux ARM. The provision of an ARM version is particularly interesting as it opens up the opportunity to run

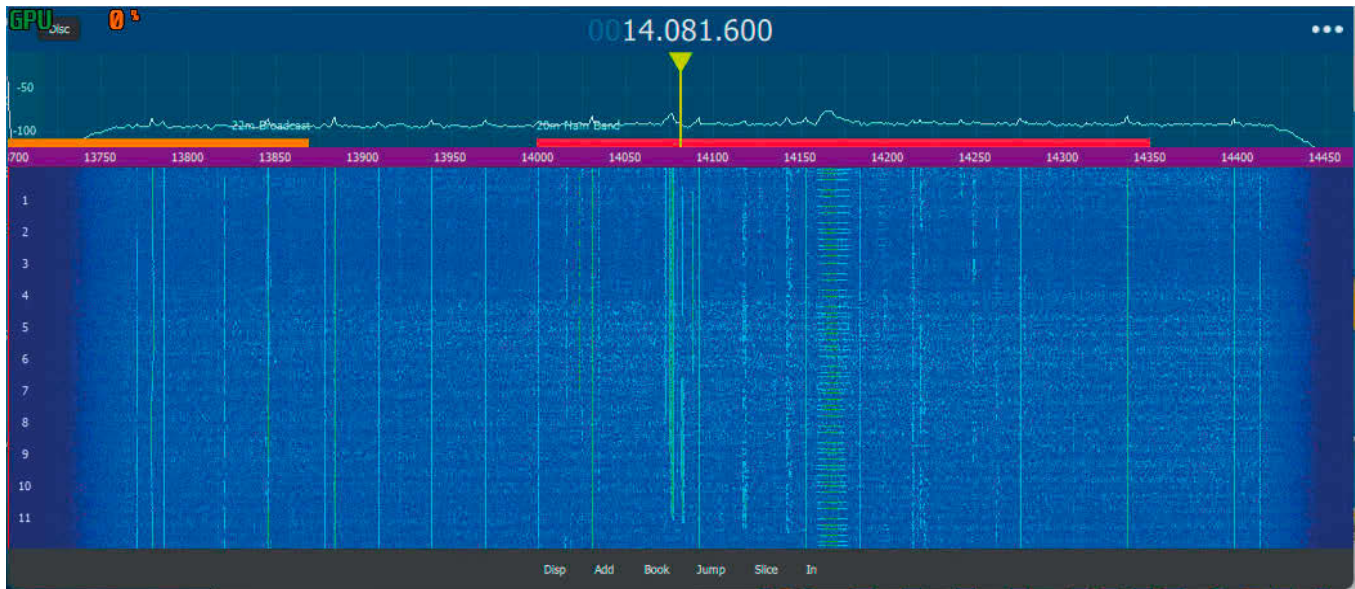

Receiver controls

5

Tag	Information
<CALL>	My callsign
<NAME>	My name
<QTH>	My QTH
<LOC>	My locator
<RIG>	My rig
<ANT>	My antenna
<PWR>	My transmit power

Table 1: VarAC Tags

the server on a Raspberry Pi 4B, which makes for a very compact SDR server installation. Installation instructions for the MagicLink server can be found here:

<https://magicsdr.com/tutorials/magiclink>

I've had the server running successfully on a Pi 4B and have been able to use an Airspy HF+ Discovery over my local network. You can also make the server available over the wider internet by using port forwarding on your router. The default port and the one to forward is 56388. You will need to refer to your router's manual to figure out the port forwarding method, as they are all different.

Once you have MagicSDR running, it has a very clean interface, as shown in Fig. 5. Tuning can be done by positioning the mouse cursor over a digit in the display and using the mouse wheel. You can also drag the central tuning ribbon or click-tune anywhere on the current display. For large frequency changes, you can use the Jump button at the bottom of the display and enter the required frequency.

For commonly used frequencies, the Add button lets you save a bookmark, and the Book button provides bookmark management. The



Slice button is where you access the mode and other receiver controls.

The interface generally works very well, but MagicSDR and MagicLink are still in development, and I had a few crashes while using it. Still, it's an interesting project, and it does enable remote monitoring so you can keep an eye on conditions when you're away from the shack.

Simon's World Map

Simon Brown G4ELI of SDR-Console fame, has recently given his World Map application a major refresh to version 1.3.3. I can't do it justice in a few words here, but it is a very powerful tool, Fig. 6. In addition to displaying a configurable map, the display can be overlaid with greyline, satellite tracks, Aurora prediction, Prefixes, Maidenhead

locator, Moon footprint and many more. It also includes rotator support for ERC Mini, ERC V4 and all Yaesu GS232A/B rotators. The time can also be set to any point in the past or future. Simon's World Map is supplied free of charge for radio amateurs, though I strongly recommend making a donation to support his excellent work. The latest version is available from here:

www.g4eli.com/world-map

WSJT-X vs JTDX Comparison

I was hoping to be able to release the results of my latest comparison this month but I've hit a few snags. I'm hoping to have it ready for next month. I'll finish off by thanking you for supporting my column and I hope you and your families have a wonderful Christmas and New Year. **PW**

Don Field G3XTT

practicalwireless@warnersgroup.co.uk

We haven't run a book review for a while but I thought readers might want some suggestions for Christmas and the RSGB Convention (see last month's write-up) gave me the opportunity to pigeon-hole **Mark Allgar**, RSGB Marketing Manager, and find out what was new and potentially of interest. Indeed, the RSGB publishing 'machine' seems to have been busy of late with a wide range of new titles. I settled on looking at the two reviewed here, but it's well worth taking a look at what else they have on offer (many of which are available via our own **radioenthusiast.com** website).

NanoVNAs Explained

In recent years we have reviewed the popular varieties of NanoVNA and carried several articles about how to get the best out of this versatile device. But regular *PW* contributor **Mike Richards G4WNC** has gone one better and written a book that describes itself as 'A Practical Guide to Nano Vector Network Analysers'. What's not to like?

VNAs have been used in laboratories for many years, but at a cost of thousands. For the more serious amateur, the excellent DG8SAQ VNA from SDR-Kits has been available for some time now with various versions starting from around £300. But what transformed the opportunities for the 'average' amateur has been availability of the NanoVNA in its various forms for prices well under £100.

However, as Mike says in the Preface to the book, "While the availability of a VNA at this price is very attractive, new users face a steep learning curve before they can trust their results. A scan through the NanoVNA user forums will reveal plenty of frustrated users battling to understand the technology". This is hardly surprising. The VNA is a complex, albeit very versatile instrument and if it isn't being used daily, frustration can set in and the unit be put on a shelf and left.

And this is where Mike's book comes to the rescue. It is in two parts, the first of which helps the user to understand S parameters, the Smith chart, the need for calibration, shortcomings and their mitigation, along with an analysis and comparison of the various models available and the software that can be used with them.

This is all good and well worth a read. But perhaps the most useful part of the book is the second part, where Mike takes us step by step through the various measurements that the NanoVNA allows us to make. Yes, checking antennas, of course, but that's perhaps more easily done with a standard, easy-to-use antenna analyser. However, he then goes on to measuring feeder loss, resonant stubs, switches and relays, filters and attenuators, directional couplers and much more. I will particularly value his advice on measuring com-

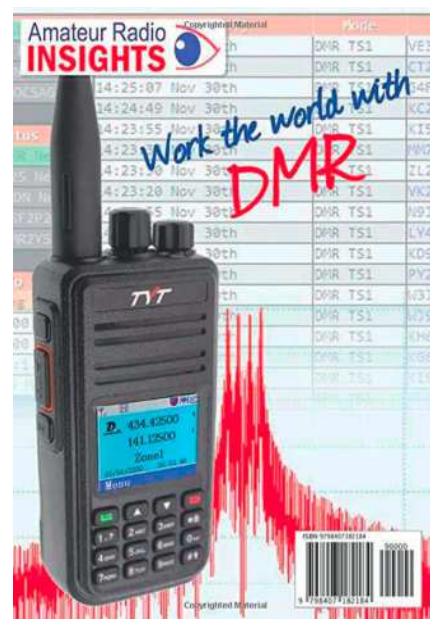
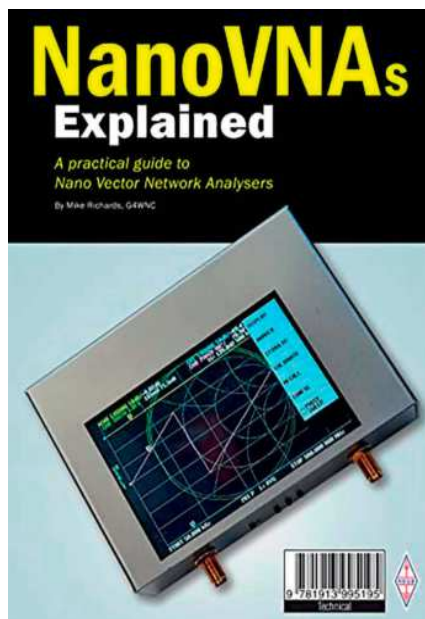

NanoVNAs & DMR

Don G3XTT looks at two new books from the RSGB.

mon mode chokes, baluns and ununs because the standard charts often give a misleading impression of how effective these are when using a particular ferrite material, number of turns, etc. Better to make one up and actually measure the results.

The book finishes, usefully, with a menu map for the two main variants of the NanoVNA – a handy reference.

Work the World with DMR

Andrew Barron ZL3DW has become well known in recent years for his excellent guides to the various current transceivers from Icom and Yaesu. I've reviewed some of the books in the past (March 2020 *PW*). More recently, he has turned his hand to writing on other topics of more general interest, one of which is Digital Mobile Radio (DMR). While DMR might not appeal to everyone, it is proving very popular, especially among new licensees and those with limited space for antennas. You can, quite literally, work the world from a handheld transceiver via a local repeater or, indeed, an even more local hotspot.

Most of you will be familiar with the fact that there are three digital voice modes available for VHF/UHF operation – DMR, D-STAR and System Fusion. The problem with DMR is that it started life as a commercial standard and is therefore not directly suited to amateur radio operation. Commercial users would be handed a pre-programmed set and would simply have to turn it on and use it. For amateur radio use, we need to program in channels, talk groups and so on. This is far from intuitive and, as Andrew says in the intro-

duction to the book, although there is a lot of help available on the internet, he felt it would be useful to have a one-stop-shop of information. And, indeed, that's why he chose DMR as the subject – because it does need some explaining to an amateur radio user but, when all set up, offers great functionality. As he says, to get the most out of DMR requires a steep learning curve but, once mastered (and it's all part of our self-training!), you really will be able to 'work the world'. Topics include what DMR is and how it works, setting up hotspots (and assembling your own from a Raspberry Pi and SD card), choice of radio, the pros and cons of DMR relative to the competing technologies, even an explanation of the many acronyms and abbreviations you will find when exploring DMR. He also takes readers through the actual setup on the more popular DMR radios available to the amateur market. The last chapter is an aid to troubleshooting if you think you've done everything right, but it still isn't working!

I have no direct experience of DMR although I am reasonably familiar with the concept, given that we have reviewed a number of DMR radios here in *PW*. But I certainly learned a lot more from reading this book. It is published by the RSGB under its 'Amateur Radio Insights' banner, which already includes a book on *Using GPS in Amateur Radio* (also by Andrew Barron), while others will no doubt follow.

NanoVNAs Explained sells for £12.99. *Work the World with DMR* sells for £15.99. Both are available from the RSGB.

www.rsgbshop.org

Read more radio news and reviews at www.radioenthusiast.co.uk/news

David A. Allen G8LHD

practicalwireless@warnersgroup.co.uk

One of the nice problems with owning a modern SDR rig is that it's like being in a proverbial candy shop, ie, so many bands to play with. What antennas to put up next in the limited environment most of us find ourselves in is a problem. If you own a long garden, then you're fortunate indeed but the rest of us have to make choices on what will the neighbours think and will it fit, all this and keeping the XYL happy that you're not invading her garden tranquillity.

So 10m was a band I had a hankering to try. I don't really have room for a beam and rotator so the antenna needed to be small, omnidirectional and mounted on a mast that was already being used to anchor one end of a tri-band inverted-U HF antenna. (It's surprising that a 7 x 7 x 7m inverted-U can work the 40, 20 and 15m bands in such a small footprint).

Back to Basics

Back to basics. The 10m band is quite wide from 28 to 29.7MHz, too wide in fact to be able to cover the whole band so you need to choose the mode you wish to use and select either the lower CW and data portion from 28.0-28.19MHz or in my case the higher SSB portion of the band that starts at 28.3MHz and extends through to 29MHz.

Use was made of antenna modelling software MMANA-GAL to optimise the element lengths and resolve what a folded halfwave square array would look like in terms of radiation resistance, gain and field pattern.

The MMANA-GAL model comprises five elements arranged as shown in **Fig. 1**. The element lengths to make up each side of a halfwave dipole are 0.25λ , so at 28.6MHz equate to $0.25 \times 300/28.6 = 2.622\text{m}$. This was the starting point for the element length optimisation in MMANA-GAL. My final optimised element lengths are shown in **Fig. 2**.

With these element lengths loaded into the modelling software and ground setup selected, which was 'Real' with the height set to 6m, we can model the performance. If we select the 'Calculate' tab and 'Start', you will observe that at 28.6MHz the antenna configuration is almost purely resistive at 10.64Ω and reactance is almost negligible, ie the antenna is resonant. If we now select 'Plots' and 'SWR' tab on the pop-up window followed by 'Detailed', we can analyse the results. Default displayed bandwidth is 400kHz but we can open this up and select 800kHz from the pull-down menu in 'BW'. If you select a new bandwidth, it will be necessary to rerun 'Detailed' to see the new results.

Fig. 3 shows the result with 800kHz bandwidth from 28.2 to 29MHz. At the band edges

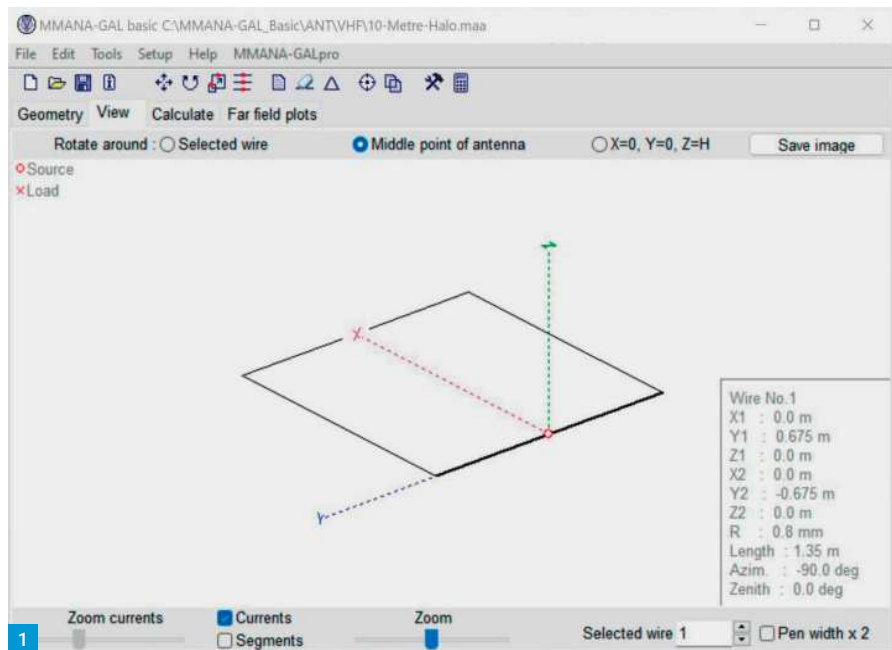

10m Band Omnidirectional Antenna Design

David Allen G8LHD describes a neat omnidirectional antenna for the 10m band.

of interest, the SWR is 5.25:1. Not so good for expecting to drive from the QTH transmitter source at 50Ω. What's needed is a 5:1 impedance transform. By far the easiest and closest match is to use two 0.25λ 50Ω coax feeders in parallel to yield a 25Ω transmission line. To visualise this, refer to **Fig. 4**, which is a model of a 25Ω , 0.25λ TLine on an impedance and admittance chart normalised to 25Ω . The left-hand side blue dot represents 12.5Ω source and the right-hand side red dot the 50Ω load. Plotting a series 0.25λ TLine between these two points gives the desired match.

MMANA-GAL simulations can be run with a matching 0.25λ TLine by changing the 'Setup' Standard Z (SWR=1) from default 50Ω to 12.5Ω . See **Fig. 5**. If we now replot the SWR in an 800kHz bandwidth, we should see the results shown in **Fig. 6**. The centre is 1.18:1 SWR rising to just over 3:1 at the band edges of interest. A much better result and within the capabilities of most auto antenna tuners.

If we now look back at 'Plots' and 'Far field plots', we can see a 2D representation of the far field plot in **Fig. 7**. It's not quite as circular as I would wish but good enough for the purpose. Main lobe elevation is at 24° .

If we now select '3D FF', we can view a complete 3D representation of the 10m antenna

mounted at 6m elevation, as shown in **Fig. 8**.

Construction

To enable optimisation the elements are made up of two sets of right-angled aluminium tubes arranged to slot into one another to adjust the resonant length and finally clamped with jubilee hose clips. **Fig. 9** shows the general dimensions when the tubes are slotted into one another (while **Figs 14** and **15** add more detail). The 615 x 620mm tubes are 12.7mm diameter by 1.22mm wall (1/2in by 18 gauge). The 705 by 554 tubes are 9.6mm diameter by 1.6mm wall (3/8in tube by 16 gauge). **NOTE:** the smaller tubes need cutting at least 800mm in length on the long side so that there is enough material to slot into the larger tube. The 50mm radius shown in the drawing has a circumference arc length of 78mm. This was formed on a plumbing pipe bender. Try not to crush the tubes. If in doubt, fill with sand before bending.

Slot the end of the larger tubes to enable the jubilee clips to clamp down onto the smaller tube. **Fig. 10** shows the general tube mounting arrangement. I would recommend using copper loaded grease on the element joints to keep water out. Element clamps were supported by a glass fibre 38mm square section tube with a wall section of about 2.7mm. A timber boom or other non-conductive support would suffice.

Sign up to our FREE email newsletter at www.radioenthusiast.co.uk

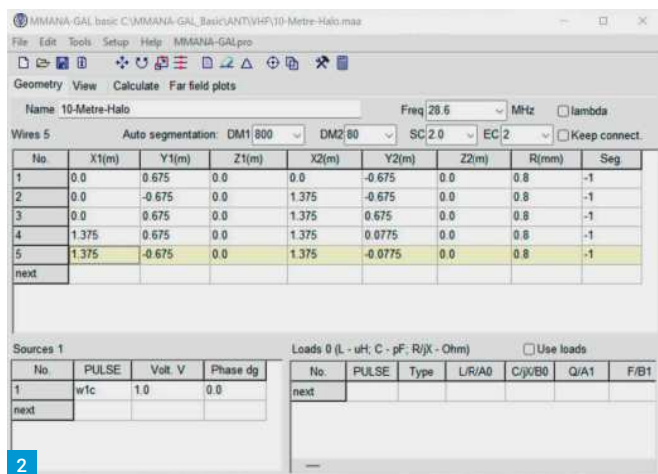
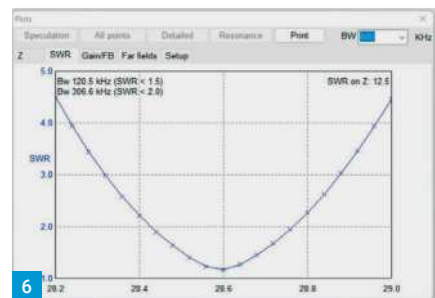
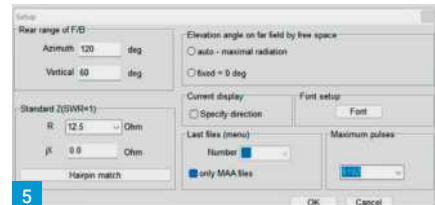
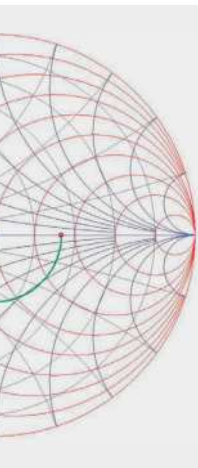
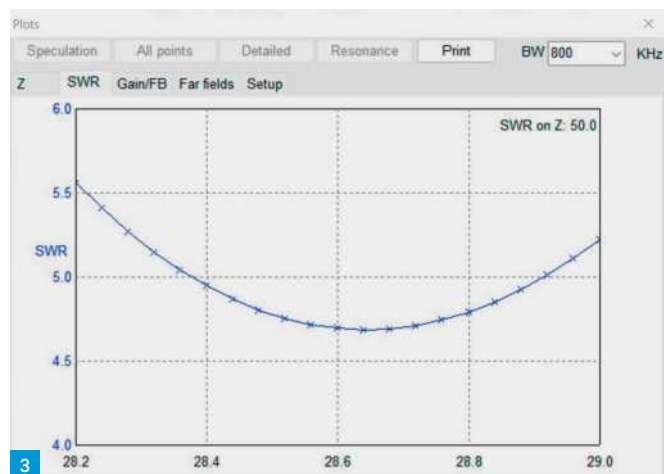

Fig. 1: Modelling on MMANA-GAL. Fig. 2: Element lengths after optimisation. Fig. 3: Initial VSWR plot. Fig. 4: Smith chart visualisation of impedance transformation. Fig. 5: Changing the default impedance in MMANA-GAL. Fig. 6: New (calculated) VSWR curve after impedance transformation. Fig. 7: 2D plot of expected polar diagram Fig. 8: A 3D plot of the radiation pattern. Fig. 9: The actual tube dimensions when slotted together. Fig. 10: General tube mounting arrangement. Fig. 11: Dipole element cap & connector. Fig. 12: Antenna Assembly in DesignSpark Mechanical. Fig. 13: The finished antenna in situ. Fig. 14: Detail of front alloy tube. Fig. 15: Detail of rear alloy tube.



Antenna Feedpoint

Fortunately, such items as dipole element feedpoint boxes used in the TV industry are readily available if you know where to look. Such a company is badland.co.uk and they have an excellent range of useful items for our hobby. One of these was a dipole cap and element clip, Fig. 11. I had to modify the cap to add an additional hole for the twin mini RG8 coax used but it served a useful purpose to keep the water out.

badland.co.uk

Coaxial Balun Arrangement

We need a balun with this antenna so this was simply provided by coiling up the 0.25λ TL line matching network. If you use Mini RG8 coax, it has a velocity of propagation of around 80%, this leaves enough length to sweep below the feedpoint and mounting bracket to the mast and coil up the excess cable with eight or nine turns to choke any earth currents on the outer braid.

A completed view of the basic antenna assembly in DesignSpark Mechanical is shown in Fig. 12, with the dipole element clamps and glass fibre tube and all the dimensions shown. A word about the 150mm gap between the two arms. I used a 10mm nylon tube with a 6.35mm bore (compressed air tube) and a length of $\frac{1}{4}$ in acetal rod to slide in the open ends of the tube and seal with glue lined heatshrink tubing. This gave added strength and the centre was subsequent-

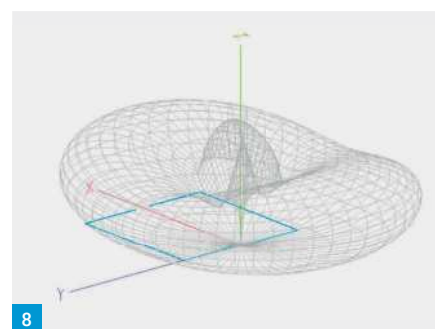
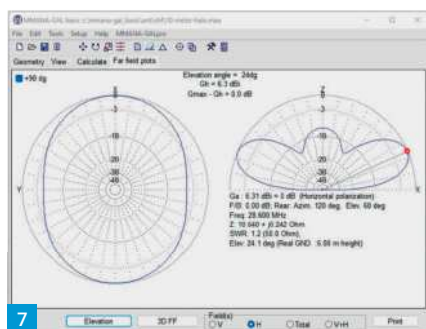

ly anchored to the top of the mast with a length of UV-proof string. This was to prevent damage from a flock of birds using the antenna as a convenient perch as my XYL insists on feeding them! The photo, Fig. 13, shows the antenna in use at home QTH.

Performance

Overall performance has been excellent, measured VSWR across the band was as shown in Table 1. In fact, no ATU was really needed in the lower portion of the band, just the top 200kHz. My first contact two days after it was put up was a station off the west coast of Mexico while using 90W on SSB. Quite a feat for a small antenna. **PW**

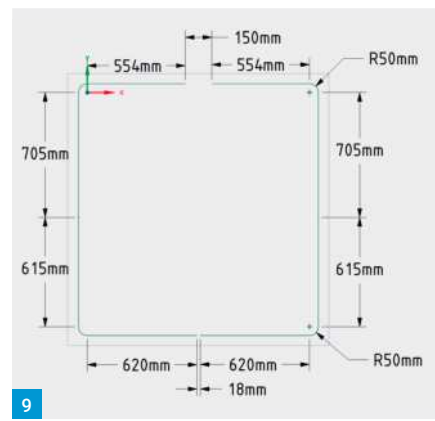

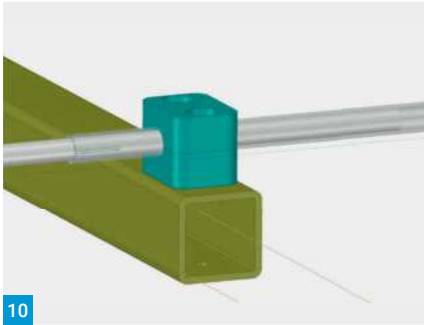

10

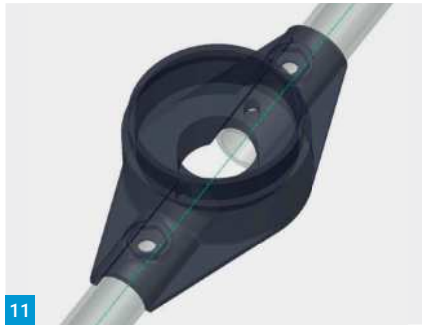

11

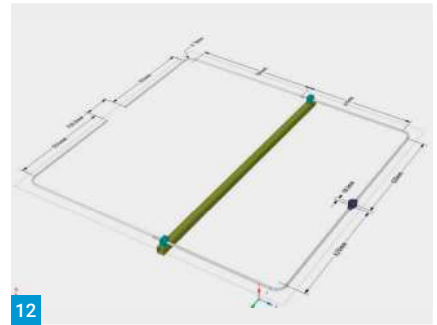

12



13

Freq (MHz)	VSWR
28.3	1.55
28.4	1.25
28.5	1.05
28.6	1.05
28.7	1.20
28.8	1.55
28.9	1.95
29	2.40

Table 1: Measured VSWR

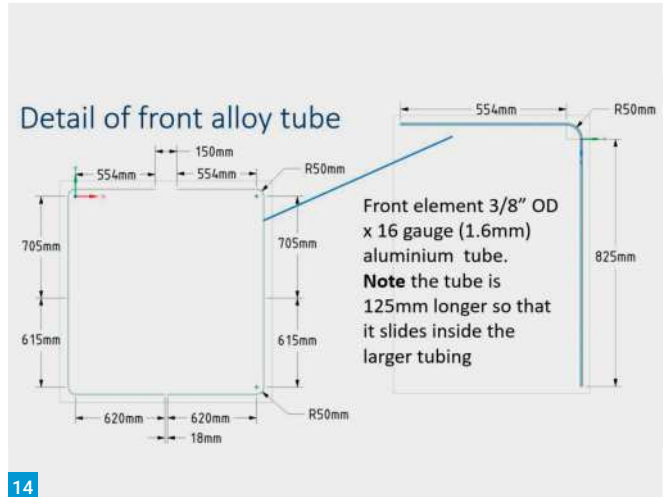

14

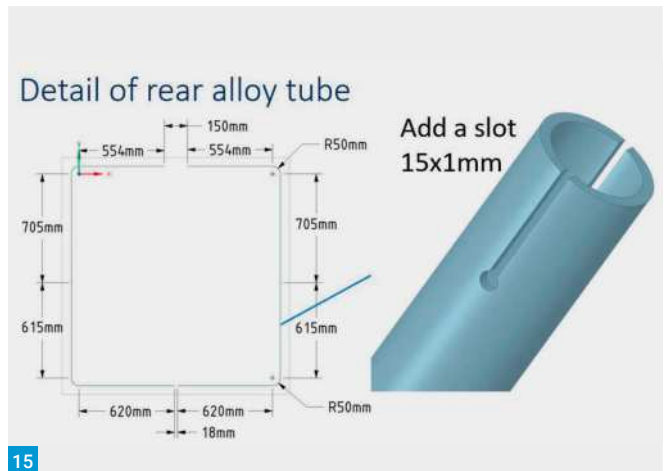

15

Parts List

- 2 Hole Element Clamp Qty 2 off, to suit half inch element.
- 2 x 1/2in 18-gauge tube at 1.5 metres.
- 2 x 3/8in 16-gauge tube at 1.5 metres.
- 1½ in square boom to mast clamp.
- Supplier Aerial Parts of Colchester:
aerial-parts.co.uk
- Dipole cap and element clip, Supplier:
www.badland.co.uk/application/brackets-masts/27
- Mini RG8 Coax, 5m should suffice.
- Main boom 1.5in Square GRP tube 1.4m length or similar non-conducting material.

Sign up to our FREE email newsletter at www.radioenthusiast.co.uk

Steve Telenius-Lowe PJ4DX
teleniuslowe@gmail.com

Happy New Year and welcome to the January *HF Highlights*. There's plenty to report again this month, so let's move on.

Propagation

Neil Clarke G0CAS sent in this report on the 28MHz beacons: As October progressed the main form of propagation was via the F-layer with DX available on most days. Paths to North America improved, with 4U1UN 28200 heard on 17 days of the month. W6WX and the high-latitude beacon VE8AT, both also on 28200, were heard for the first time this sunspot cycle on the 26th. Still on 28200, VK6RBP Australia and RR90 Asiatic Russia were both heard on numerous days. Now to Europe, where Sporadic E continued to take place on some days with most of the openings being to Italy and Spain (IQ8CZ 28230 was logged on 11 days).

SV2RSS 28265, SV6DBG 28269 and SV2HQL 28271 were heard during the summer via double-hop Sporadic E but they are now heard most days via the F2 layer. SV6DBG was heard on 20 days. Looking towards Scandinavia OH5TEN 28230 and OH9TEN 28267 were extremely strong around midday when geomagnetic activity was low but they failed to appear as soon as geomagnetic activity started to increase.

The Month on the Air

The mid-October to mid-November period offered a plethora of DXpeditions to chase. The D60AE Comoros, **Fig. 1**, DXpedition closed on 17 October with over 73,000 QSOs in their log. TY0RU from Benin started a few days earlier and was active until 30 October. By then P29RO was also well under way from Loloata Island, OC-240, in Papua New Guinea (see *HF Highlights*, November 2022). They ended up with over 95,000 QSOs. TY0RU finished with over 124,000, after which the operators crossed the border into neighbouring Togo, from where they made a further 102,000 contacts as 5V7RU. Around the same time more DXpeditions started, VK9CM from the Cocos (Keeling) Islands and J28MD, operated by members of the Mediterranean DX Club from Djibouti. A35GC from Tonga, T88WA from Palau and T33T from Banaba Island, Kiribati, all began in early November and often there were six or more DXpeditions on the air simultaneously, **Fig. 2**, giving DXers plenty to chase.

The CQ World Wide SSB contest took place at the end of October. I was one of six operators at the PJ4G contest station, **Fig. 3**, from where we made 9200 QSOs in the multi-operator, single transmitter category, including several with *PW* readers.



DXpeditions Return

Steve Telenius-Lowe PJ4DX has a packed column as DXpedition activity ramps up post-COVID and the CQ WW contest season gets into full swing.

January DXpeditions

The 'big one' is the 3Y0J DXpedition to Bouvet, one of the most remote islands and most difficult DXCC entities in the world to activate. The team plans to depart Port Stanley on 13 January for the long journey to Bouvet then to be active for 22 days on the island using eight stations on CW/SSB (with some RTTY on 14, 18 and 21MHz), plus four stations dedicated to FT8 (Fox/Hound mode) on 7 – 28MHz only. See the 3Y0J website for more details:

3y0j.no

The Czech DXpedition Group will be active as TN8K from the Congo from 7 to 20 January. This is the group that operated as TU5PCT from Côte d'Ivoire last year and as S90K from São Tomé in 2021. They'll be on SSB, CW, RTTY, FT8, FT4 and PSK on all bands from 1.8 to 50MHz with several stations on the air simultaneously. Expect strong signals and some slick operating from this experienced group. More at:

www.cdpxp.cz

Readers' News

Owen Williams G0PHY commented "There was certainly a lot of DX to chase this month with three big DXpeditions active, J28MD, 5V7RU and P29RO... In addition, there was TO2DL on Guadeloupe, SP9FIH operating as FJ/SP9FIH from St Barts, plenty of activity on 28MHz and the CQWW phone contest. Thanks for the contact on 28MHz as PJ4G in the contest."

Carl Mason GWOVSW wrote "I managed an hour

or so operating in the CQ WW SSB contest, logging 53 contacts in 25 countries on 20m running 5 watts from the G90 and using the inverted G5RV. Best DX was D4Z, TC3X and UP0L."

Steve Crask G7AHP is the new Secretary of Torbay's Riviera Amateur Radio Club, having taken over from **Steph Foster G4XKH** who stepped down after many years of dedicated service. Steve said: "The Riviera ARC ran a special event station, GB4BCR (Babbacombe Cliff Railway), on 24 September for Railways on the Air (ROTA), **Fig. 4**. Activity included HF (SSB and FT8), with contacts into VK and 9Y4 as well as several other ROTA stations... The event was enjoyed by club members, new and old."

Another new contributor, **Simon Davis-Crane G7WXX**, **Fig. 5**, wrote: "I will be active as EA6/G7WXX between 20 December 2022 and 2 January 2023. I will be using HF SSB from as many POTA parks as possible during my trip. For IOTA, the island counts as EU-004. QSL to my home call sign."

And yet another new contributor, **Ian Harvey G4COR**, wrote: "I thought that I'd send in a list of some of the better DX that I have worked since 11 October. I have not sent anything previously, so I hope that it will be useful. I've not bothered with the multitude of JA or North American stations, because there were a lot! 3V8 isn't far from the UK, but it's the first time I've worked it, ever. Antenna is an 11m tall vertical with base tuning. Rig is an FT-847 running about 50W."

Reg Williams G00OF wrote that October was:

Read more radio news and reviews at www.radioenthusiast.co.uk/news

- Fig. 1:** Moroni, capital of the Comoros. **Fig. 2:** How's this for a DX Cluster screen? Six DXpeditions active simultaneously: P29RO, 5V7RU, J28MD, A35GC, T88WA and T33T. **Fig. 3:** "And they call this wireless?!" Peter PJ4NX and Marty W1MD at the PJ4G contest station. **Fig. 4:** Ian G6TEQ and Steve G7AHP operating GB4BCR at the Riviera ARC. **Fig. 5:** New contributor Simon who plans activity as EA6/G7WKX. **Fig. 6:** G3JNB's veteran HW8 back on the air. **Fig. 7:** Spectrum around 21240kHz at ZB2GI during the CQ WW SSB contest. **Fig. 8:** Carl 2E0HPI/P at Fairfield, 873m high in the Lake District National Park.

"a very productive month for me on FT8 and SSB." Reg worked several VK stations and one ZL in the Oceania SSB contest at the beginning of the month. The majority of his contacts were on FT8, though, highlights being FK8HM New Caledonia, KG6JDX Guam, YJ8RN Vanuatu and RI1ANU in Antarctica. On SSB Reg's highlights included TO2DL Guadeloupe, V31XX Belize and the D60AE Comoros DXpedition. "At the end of the month was the CQWW SSB contest... Conditions were especially good on 28MHz where I made the most contacts, including 7Q6M Malawi, V55Y Namibia and many islands in the Caribbean. [14 and 21MHz] were rewarding in my quest as well, from Australia to Alaska with Reunion Island along the way, not forgetting the PJ4G team from Bonaire, **Steve PJ4DX** happened to be operating at the time I responded to their call. A good month ending with a great contest. The Hustler vertical antenna and a DX Commander Rapide vertical performed well."

Victor Brand G3JNB said that "Much of my time in October was spent developing my capability with the increasingly-popular VarAC digi mode. This 'keyboard-to-keyboard' program is remarkable and I have started to enjoy live 'digi chats' again. Connection to PSK Reporter, directly from the operating Window, enables an immediate world map showing the coverage of my 20W signals, both Beacon and CQ calls. The first 'ping' to a DX direct 'connection' was on 20m with VK2ATW... As I had been 'overdoing' the digi thing, I sought a little relaxation by quickly lashing together my elderly Heathkit HW8 with an SWR meter and ATU, **Fig. 6**, for a little QRP therapy! Now offering only 1W or less of RF, it was heartening to have **Norman GM4KGK** in Stornoway come straight back for a nice CW chat on 40m.

"The D60AE team on the Comoros proved difficult in their early days with huge pile-ups and deep QSB. But eventually I got through... Now that Cycle 25 is well under way and we can look forward to the good times, it has been heartening to hear the big increase in CW DXers back on HF and chasing exotic callsigns. Big pile-ups are already the norm. Paradoxically,

WX1S	24890.9	A35GC	23:14 07 Nov	up 1.3	Tonga
K4SUS	24891.0	A35GC	23:13 07 Nov	wkd up 1	Tonga
HA6NY	3519.0	J28MD	23:13 07 Nov		Djibouti
W8HAP-@	24891.0	A35GC	23:13 07 Nov	579 on East Coast	Tonga
K2RET	24891.0	A35GC	23:12 07 Nov	up 1.4	Tonga
JA1PPD-@	21091.7	T88WA	23:11 07 Nov	FT8 TNX	Palau
KN4SA	28485.0	T88WA	23:10 07 Nov		Palau
K4KGG-@	3500.0	5V7RU	23:08 07 Nov	NA??	Togo
VK2HV	28485.0	T88WA	23:08 07 Nov	NA & SA up 5	Palau
N1API	18100.0	P29RO	23:08 07 Nov	FT8	Papua New Guinea
N2FRB	21274.8	5V7RU	23:07 07 Nov		Togo
TA4RC	3519.0	J28MD	23:06 07 Nov	pse as ta last hour	Djibouti
K4SUS	28485.0	T88WA	23:05 07 Nov	wkd up 5	Palau
W0OGH	24915.0	5V7RU	23:05 07 Nov	TU new band <->	Togo
K4NV	28485.0	T88WA	23:05 07 Nov		Palau
K5GET	10108.0	J28MD	23:04 07 Nov		Djibouti
2 8AT-@	21075.4	T33T	23:03 07 Nov	FT8	Banaba Island



this reduces my capability to slip past other callers to catch the ears of a DXpedition. Why? Well, in the long, dark days of the minimum, DX stations that could be copied by the lower-power operators with modest aerials but living in very quiet locations, had to listen hard for callers. Now, they are once again besieged by the huge number of very strong stations, their success depends upon the reduction of RF gain, and adroit use of narrow filters, to pick out the next caller from the cacophony. Time for us to up our game!"

Jim Bovill PA3FDR sent in a very long list of stations worked for the 'Band Highlights' section below, which I have had to edit quite severely. Jim added: "While most of the QSOs in my reports are DX, and chasing DX provides the greatest challenge, I also very much enjoy my contacts with local European hams... with locations among the smallest independent or (semi) autonomous DXCC entities in the continent. They were Svalbard (JW9DL) with a population fewer than 3000, the Faroe Islands (OY1R), Åland Islands (OHOKCE), Liechtenstein (HB0RER), Andorra (C37URA), San Marino (T77C) and Gibraltar (ZB2MR). The latter two have populations less

than that of Uithoorn, the town where I live, population just over 35,000."

Jim mentioned contacts with HK5WML, CX1NU, HC1MD (a new DXCC entity for him), as well as the TY0RU DXpedition. "There is one other QSO I have to mention as an Irishman: EI90IRTS. This is a special callsign issued to mark 90 years since the founding of the Irish Radio Transmitters Society." Jim forwarded these interesting details from the EI90IRTS QRZ.com page: "Amateur radio in Ireland goes back a long way. **Colonel Meade Dennis** became interested in radio transmission after hearing a talk on the subject in Dublin in August 1898 and constructed a spark transmitter and receiver, sending and receiving messages over a distance of 64 metres, making him possibly the first amateur radio experimenter in the world." The EI90IRTS QRZ.com page contains an entry from Colonel Dennis's diary and a photograph of the spark transmitter used for his 1898 experimental transmissions.

From the Netherlands across the border to Belgium, where **Etienne Vrebos OS8D** spent more time on the radio this month due to the inclement weather around Brussels. "This month about 300

Sign up to our FREE email newsletter at www.radioenthusiast.co.uk



QSOs and I worked a lot on 10m, wide open... As usual, all SSB on Icom IC-7851 and Acom 1500 [and] the great working Hexbeam."

Tim Kirby GW4VXE reported that "Ten metres has been excellent and although I've enjoyed some DX contacts, I've also enjoyed some CW 'rag-chews' with stations running fairly simple aerials, such as dipoles and verticals, well into the USA. It's also been good to hear some west coast stations coming through well around sunset. An enjoyable addition to the shack has been **Simon's G4ELI** World Map program. It can do all sorts of things, but it is a nice display of the greyline and solar conditions. It's free too!

www.g4eli.com/world-map

"Highlights on 10m CW have been OA1F, V31XX, CX5FK, ZF2MJ, TY0RU, J28MD, CN8YR, KP2M, Z68XX, V4/K5ZD, ZA1EM, 3B9FR, 5V7RU, PJ2/KB7Q and VU2TMP. I've also heard a few stations coming through on 10m AM and am looking forward to getting the converted CB set going and whip on the car and see if I can make some AM QSOs into the USA again this winter. Much as I enjoy digital comms and the like, there's something very soothing about hearing the rounded tones of an AM signal fading up and down!"

During October **Kevin Hewitt ZB2GI** made around 800 QSOs from his home station, the Gibraltar ARS club station, and portable from Coaling Island and the top of the Rock. **Fig. 7** shows the spectrum around 21240kHz in Gibraltar during the CQ WW SSB contest, just using a 5m wire connected via a 9:1 balun.

Carl Gorse 2E0HPI wrote that he and **Anthony MOVED** "decided to do two SOTA summits in the Lake District National Park. The walk consisted of 15 miles over rough terrain; the paths were like streams. The first summit was G/LD-007 Fairfield 873m, **Fig. 8**, with 54 QSOs in the log, mainly in the UK though I managed to work



JH1GEX on 20m just before we packed away to head to St Sunday Crag, 843m, G/LD-010. Mainly worked on 40m [from there] with around 30 logged and then we had to make the way down back to Patterdale." Carl added that when the weather is OK he now operates FT8 as well as SSB while portable, using a laptop with Yaesu SCU-17 interface.

Band Highlights

Owen G0PHY: 7MHz SSB: KP3DX. **14MHz SSB:** 4U11TU, FM5KC, PJ2T, V26B. **18MHz SSB:** J28MD, TO2DL. **21MHz SSB:** FJ/SP9FIH, P40T, PJ4G. **24MHz SSB:** FJ/SP9FIH. **28MHz SSB:** J28MD, PJ2T, PJ4G, TO2DL, V47FWX, ZF2WF.

Ian G4COR: 7MHz FT8: 5V7RU, JT1CO. **10MHz FT8:** 9Y4DG, CN8ZG, OD5ZZ, VK6AL. **14MHz FT8:** BG0CAB, CX1FK. **14MHz FT4:** CU5ACD, LW4EAZ, OY1R, YC1IFR, YV5JAU. **18MHz FT8:** TY0RU, VK5PO, VP2EIH. **18MHz FT4:** 5V7RU, HC1MD/2, YV7PMG. **21MHz SSB:** 3V8SS, PJ2T. **21MHz FT8:** TY0RU. **21MHz FT4:** BD6RN, HS2AQQ, YB1TDL, YV7PMG. **24MHz FT8:** 5V7RU, 9K2YM, A65/DL2RMC, AP2NK, B11KFY, HK3X, J68HZ, TY0RU. **24MHz FT4:** CX2AQ, HC6IM, HI3MM, PZ5RA, V31MA, XE2EX. **28MHz**

FT8: 5V7RU, 9K2YM, HC5F, TY0RU. **28MHz FT4:** 3C3CA, 9G1SD, 9K2TV, 9Z4CH, A41DX, CE2SV, CX9BU, EX8BT, E23IBS, FG5GP, HP1RY, HS5NMF, XE2KK, ZR6JT.

Reg G000F: 10MHz FT8: BD6AHK, CX1RL, D60AE, FR40M, HS0ZOY, JA1JRK, KG6JDX, RI1ANU, TO2DL, TY0RU, VK2NP, YJ8RN, ZL2UB.

14MHz SSB: FM5KC, KL7RA, VK7QP, ZL4RMF.

14MHz FT8: 3W/SP6TPP, BD7JJQ, DU6/PE1NSQ, FR40M, JH1OBS, TY0RU. **21MHz SSB:** CE1TT, FM5KC, N7PMS, PJ4G. **28MHz SSB:** 7Q7M, CB6LR, D60AE, FR4KR, FY5KE, KP2B, PJ2T, TO2DL, V26B, V31XX, V47T, V55Y.

Kevin ZB2GI: 14MHz SSB: E51JD. **21MHz SSB:** KP4AK, PY4JW, PY7ZZ, W7WA, ZS1WY. **21MHz AM:** WB1EAD. **21MHz FT8:** EK/RX3DPK, JA8CEA, VK3AXI. **24MHz SSB:** N4OHI. **24MHz FT8:** LU7DUE. **28MHz SSB:** 6Y5CB, 9Z4FE, CO2XN, CX8DS, K6YRA, LU1DTL, NP4CR, PY4YY, TI2SD, V26B, WP3ZN, XE2AD. **28MHz AM:** WB8KRY. **28MHz FM:** KQ2H & VE3MMX repeaters. **28MHz FT8:** 7Q7CT, AA6IO, HI3T, JA7AUM, VA7RY, XE2CQ. **28MHz FT4:** FG5GH, KC7ES, OD5ZZ, XE2EX.

Continued on page 65

THE "VICTOR" VICTORIOUS!

**THE FASTEST TIME
IN THE WORLD.**

All Previous Record Broken

AT THE
TELEGRAPHERS' TOURNAMENT

In New York, on April 5, 1885.

**Improved
VICTOR
KEY
Price,
\$2.50**

**500 Words, 2,368 Characters, sent in 10
Min. 32 Sec.,**

ON THE
"IMPROVED VICTOR"
TELEGRAPH KEY.

Send for Descriptive Circular.

LIVE MEN WANT LIVE KEYS!

Tony Smith G4FAI
g4fai@btinternet.com

Morse Speed Champions

Tony Smith G4FAI narrates the history of Morse speed championships.

By the 1880s, professional telegraphers in the US were participating in regular Morse speed contests. According to an advertisement for the Tillotson/Greeley 'Improved' Victor hand key, the winner of the Telegraphers' Tournament in New York on 5 April 1885, using the Victor key, sent 500 words in 10 minutes, 32 seconds. This result, the advertisement claimed, was 'the fastest time in the world'.

As American Morse is about 10% faster than International code, his record speed of 47.5 words per minute (wpm) was equivalent to 42.75 wpm in International Morse. This is an approximate figure as American Morse does not have defined dot/dash/spacing similar to the 50-bit PARIS standard, which helps to define wpm in International Morse.

George W Conkling

Another professional, **George Conkling** won the Grand National Telegraph Tournament at Madison Square Garden, New York, in May 1898. He sent 345 words in five minutes, defeating his nearest rival by nearly 15 wpm. At 69 wpm, American Morse, this was about 62.1 wpm in International Morse. At this speed, he must have been using a semi-automatic 'bug' key.

Ted McElroy

After WWI, until the late 1930s, speed contests among radio amateurs, which were also open to professional telegraphers, were held under the sponsorship of the American Radio Relay League (ARRL).

Ted R McElroy, who was a Western Union messenger at the age of 14, and a professional telegrapher a year later, was the World's Receiving Speed Champion in 1922, 1935 and 1939. He was skilled in both the American and International codes; and qualified as a licensed radio amateur in 1925 with the call W1JYN.

Joseph W Chaplin

At the ARRL Convention in Chicago, in August 1933, having been the Champion since 1922, with 56.5 wpm, McElroy was defeated by **Joseph W Chaplin**.

The event was reported in *QST*, journal of the ARRL, in November 1933. Each section of the test tape ran for five minutes at increasing speeds, controlled by a Wheatstone automatic keyer. Headphones were provided for the contestants who received the test signals at an oscillator generated frequency of 1000 cycles (1kHz). As they reached their speed limits, they left the test room, leaving eight finalists to compete in the final run.

The test tape, prepared and sealed in New York, was opened by **Inspector Hayes** of the Chicago office of the Federal Radio Commission immediately prior to the final run. It was in plain English, taken from the Chicago newspapers, and edited to contain no difficult or unusual words or figures, with only the simplest punctuation.

It began at 40, then 45, then 50, 53, 54.1, 57.3 and 61.6 wpm. The machine could not be accurately pre-set at these speeds, and they were determined afterwards by counting the words against the time that had elapsed.

New Record

A maximum of 1% error was allowed for each five-minute run. At 61.6 wpm the two leaders, Chaplin and McElroy, both had more than 1% errors. At the lower speed of 57.3 wpm Chaplin had only 11 errors out of an allowable 14 and was declared the winner, breaking McElroy's 11-year International Morse record of 56.5 wpm.

Jumble of Dots and Dashes

Under the heading 'New Code Champion!' *QST*, October 1935, reported how McElroy was gradually increasing his speed in contests, while other crack operators were not far behind him:

"TR McElroy is the new World's Code Speed Champion! In one of the most brilliantly contested tournaments ever held this operator led all participants in a World's Championship Radio (International) Code contest held at the Brockton, Mass. Fair on September 14th.

*"J. W. Chaplin, who established the record of 57.3 wpm at the World's Fair in Chicago, put up an admirable fight to hold the title, being bettered by only one error. McElroy copied 69 wpm with two errors only, while Chaplin copied the same speed making three errors. The other three of the five contestants were **JB Donnelly** and **VS Kearney** of New York, and **JS Carter** of Boston.*

"All five contestants broke the previous 57.3 wpm record!! Those who witnessed the tournament could but marvel at the ease with which all participants copied speeds which sound like a mere jumble of dots and dashes to the average operator... Hats off to the new Champion, Ted R. McElroy!"

Final Record

The last of these Championships was held on 2 July 1939 at Ashville, North Carolina, with, as previously, an automatic Wheatstone keyer pulling punched tape through its reading head and an audio oscillator producing the tone signals.

Competitors were again provided with headphones and manual typewriters to copy the code. The winner was Ted McElroy, back on form, who

Sign up to our FREE email newsletter at www.radioenthusiast.co.uk

took down press copy at 75.2 words per minute, still an unbroken world record.

From 1934 to 1942, capitalising on his success and fame, McElroy manufactured his own brand of Morse keys, including the famous Mac-Keys.

Harry Turner

In 1942 **Harry Turner W9YZE** became the world champion hand-key operator. His record of 35 wpm, using International Morse, has never been beaten and his feat has been noted in the *Guinness Book of Records* since 1981.

By the age of ten he knew American Morse. He went to work on the railroad at 14, working as an 'extra' (relief telegrapher). He learned the International code in the Navy and finally joined the army where, in October/November 1942, he was under training at the Signal Corps School, Camp Crowder, Missouri.

He recalled the event in later years: "Having known both codes and worked with them, I graduated in one month. The army did not teach me any of it."

He was at the School only to obtain formal recognition of his ability for a military grading. On 9 November 1942, in the presence of **General Ben Lear**, Sixth Army Commander, who was visiting the School, Harry demonstrated his skill, sending International code at 35 words per minute into a recording machine.

"I sent for the full five minutes and then copied it all back, no mistakes. I have a certificate from the US War Department regarding this record.

"I really did not try for a record. I was just putting on a demonstration for the General. It made him feel good to think the School was turning out such fast operators, but the top speed of the operators that the School really did turn out was not over 20 words per minute sending and receiving.... they were taught to print. I copied my test in longhand. That was what we had to do on the railroad, everything copied on a typewriter or in longhand."

Challenge

In 1989 the BBC *Record Breakers* programme issued a challenge for someone to try to break Harry's record. However, the widespread use of electronic keyers and semi-automatic keys for fast work had long destroyed the old competitive spirit in this field, and no high-speed hand-key operators took up the challenge.

Harry always wanted someone to try to beat his record but, he said, "they would have to have a lot of practice." He died on 21 December 1994, aged 88, the proud owner of one record that will probably never be broken.

Modern High-Speed Champions

There is still an interest in high-speed telegraphy (HST) in the amateur radio service in the form of the annual International Amateur Radio Union (IARU) HST Championships. At these, the winners

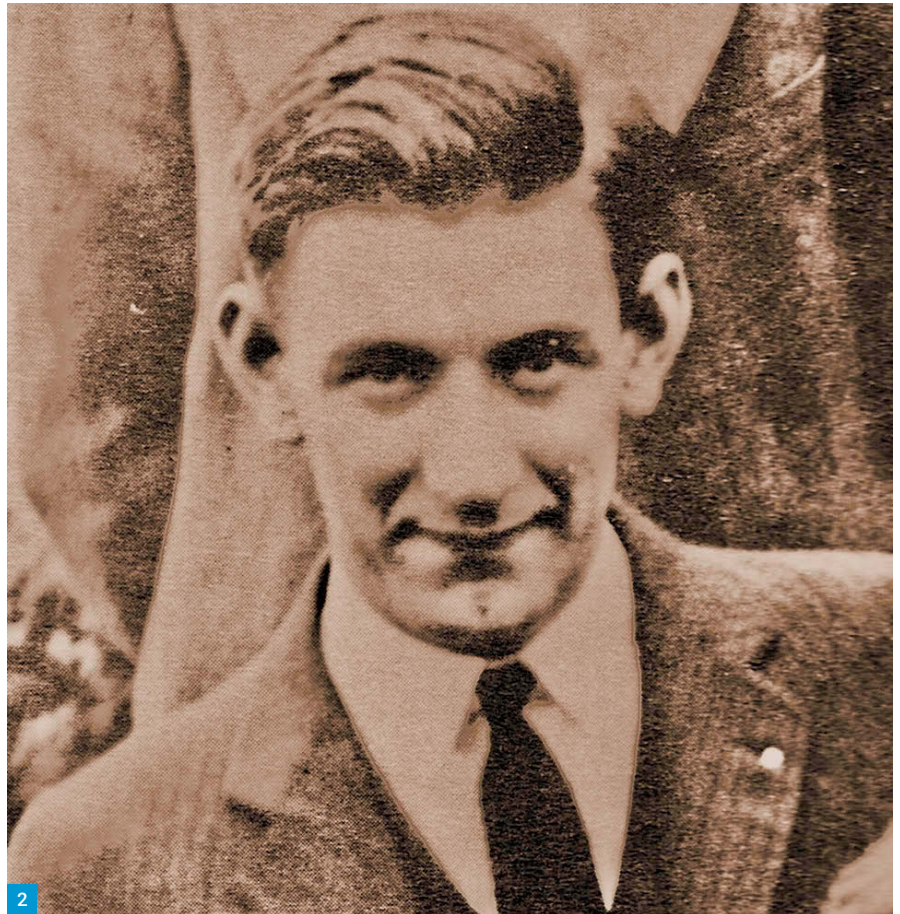

2

T. R. McELROY

World's Champion Radio Telegrapher

23 BAYSIDE STREET
UPHAMS CORNER P. O.
BOSTON, MASS.



Official Record
69 wpm Brockton 1935



51 WPM 1920
56 1/2 WPM 1922
55 WPM 1921

You can send better with a MAC KEY or your money refunded after five day trial

1. Massively constructed base and superstructure one solid casting. Vibrationless.
2. Name plate with serial number for operator's protection.
3. Binding post. Other post is number 19.
4. Vibration dampener on swivel so may be thrown out of way for handling weights.
5. Vibration dampener adjustment screw so that roll hits rod exact center.
6. Vibration dampener roll in machined slot for beautifully stutlerproof sending.
7. Straight key changeover lever, locks rod for shipping and handling also.

8. Speed governor weights. 5 wpm to 30 wpm.
9. Vibrating rod.
10. Dot U spring holding and adjusting collar. This U spring formed in a die out of highest quality Swedish blood steel of exact weight desired and then Parkerized for longevity.
11. Main spring also selected after exhaustive experimenting for correct weight and also Parkerized.
12. Main lever yoke casting which provides the excellent dash lever suspension.
13. Dot lever back stop screw.
14. Dot lever travel screw.
15. and 16. Dot and Dash contact screws on solid bar for perfect alignment.
17. Thumb peddle for dots.
18. Dash button for first and second fingers.
19. Binding post. Other post is number 3.
20. Dash lever spring (Parkerized) and adjustment nut.
21. Dot lever spring (Parkerized) and adjustment nut assembly.
22. Dash lever and Dot lever bearing adjustment screws.

\$7.95
f.o.b. Boston

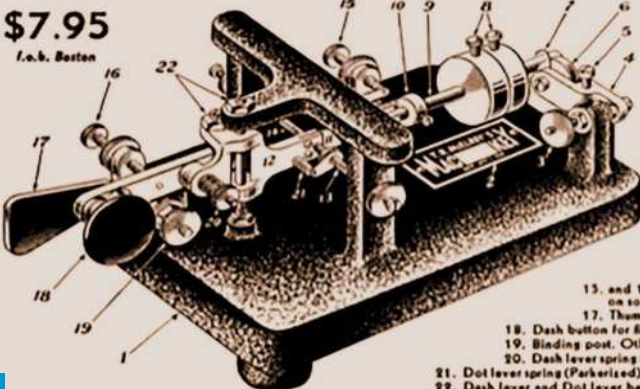

3

Read more radio news and reviews at www.radioenthusiast.co.uk/news

achieve speeds apparently higher than those of the earlier champions, but against different criteria, sending or receiving limited copy over much shorter periods of time.

Variety of Tests

Laptops can be used for receiving and are, of course, much faster with their easier action and shorter key throw than the old manual typewriters. With such a facility, the earlier champions could well have achieved greater speeds themselves.

Competitors may also copy by hand if they wish, using symbols or shorthand of their choice, but their copy must be typed out in full in the 30 minutes following the end of a test, and handed to the adjudicators. The rules are somewhat complicated and can be found in full at:

<https://tinyurl.com/yxohx654>

A variety of tests involve sending and receiving groups of letters, figures or mixed groups each for a period of one minute at different speeds. Competitors are awarded points based on their performances, and these points are totalled to identify the overall winner of the event, making it difficult to identify a champion in the old way.

Speeds Achieved

Individual speeds for particular sections can, however, be identified and include the following IARU HST world records:

RECEIVING TESTS MALES

Letters: **Evgeni Pachnine RV9CPV**, 300 characters/min (cpm). (1999).

Figures: **Oleg Ostrovski EW8NW**, 320 cpm, (2009).

Mixed: **Siarhei Shviadko EW7SH**, 250 cpm, (2005).

RECEIVING TESTS FEMALES

Letters: **Hanna Shvialenka EW8NK**, 300 cpm, (2016).

Figures: **Hanna Shvialenka EW8NK**, 320 cpm, (2018).

Mixed: **Anna Sadoukova RA4FVL**, 260 cpm, (2017).

TRANSMITTING TESTS MALES

Letters: **Andrei Bindasov EU7KI**, 283 cpm, (2007).

Figures: **Oleg Ostrovski EW8NW**, 254 cpm, (2006).

Mixed: **Andrei Bindasov EU7KI**, 230 cpm, (2006).

TRANSMITTING TESTS FEMALES

Letters: **Iryna Tsyatserskaya EW1YI**, 260 cpm, (2008).

Figures: **Hanna Shvialenka EW8NK**, 242 cpm, (2018).

Mixed: **Iryna Tsyatserskaya EW1YI**, 217 cpm (2007).

Comparison Not Possible

Converting the characters per minute (or marks per minute as the rules define them) to words per



minute(wpm) is somewhat arbitrary but for a simple comparison with older records, the cpm count can be divided by five.

EW8NW and EW8NK's receiving speed of 320 cpm, for figures only, equates to 64 wpm, still somewhat less than Ted McElroy's 75.2 (71.6) wpm of press copy in 1939!

EU7KI's transmission of groups of five letters for one minute at 283 cpm, is an impressive speed, equal to 56.6 wpm, but it is still less than George Conkling's achievement in 1898, sending text for five minutes at (approximately) 62.1 wpm.

In the IARU championships, the time allowed for sending each group is only one minute and there is no requirement to read it back. The reception tests are also set over a period of one minute.

Contestants can choose which sections to enter, so a champion in a particular transmitting section is not necessarily a champion in the corresponding receiving section. They can choose to be tested for transmitting or for receiving, or both. They can choose figures alone, letters alone, mixed groups alone or some or all of them.

Exceptional Skills

Whatever sections they choose, the results undoubtedly demonstrate exceptional skills in high-speed telegraphy. One wonders, however, if the speeds achieved could be sustained over longer periods and if the transmitted copy could be as easily and accurately read back as it was in some of the older contests.

While there are separate sections, by age, for male and female participants, there are further tests for those who wish to demonstrate their skills in other ways.

These include the RUFZ call sign receiving program (URL below), when competitors copy 50 real amateur radio calls at increasing or decreasing

Photo 1: Tillotson/Greeley Improved Victor key, 1886. Photo 2: Ted McElroy World's Receiving Speed Champion c1925. Photo 3: Advertisement for a Mac-Key. Photo 4: Harry Turner, taking part in a Morse Telegraph Club international wire hook-up, 1978. Photo 5: The Belarus team, World HST champions 2018. Photo 6: Stanislau Hauralenka EW8GS and Teodora Karastoyanova LZ2CWW, modern-day champions.

speeds, depending on how accurately they copy the calls, again with points awarded on performance. In 2019, record speeds of 195 wpm were attained in this test by **Stanislau Hauralenka EW8GS** and **Teodora Karastoyanova LZ2CWW**.

www.rufzxp.net

Another test, the 'Morse Runner', is a simulation of real pileups on the air. Two attempts, each lasting ten minutes, are allowed, at a speed chosen by the contestant. A demonstration of this test can be seen and heard at:

<https://tinyurl.com/y49mauol>

Covid Cancellation

The 16th IARU HST Championship was held at Albena, Bulgaria in September 2019. It was attended by 90 competitors from 19 countries with Belarus the winning team. The next championship, the 17th, planned for August 2020 at Ulaanbaatar, Mongolia, was cancelled due to the Covid-19 pandemic,

The 17th was finally held in Montenegro in Sep 2021, with 120 contestants from 17 countries taking part. No world records were broken on this occasion.

A video of this event can be seen at the link below with some impressive shots of contestants keying during a practice session.

<https://dxnews.com/hst-world-montenegro>



5



6a

The 18th HST Championships were held in Sokobanja, Serbia in September 2022 with 73 participants from 13 countries. The final Team results were 1st Belarus, 2nd Russian Federation and 3rd, Romania.

In the Female class, **Teodora Karastoyanover LZ2CWW** created a new world record for the MorseRunner pile-up test with 4843 points compared to the previous record of 4686.

Invitations for 2023

The next Championship, the 19th, will be held in 2023. When the venue has been announced IARU societies will be invited to send national teams to participate. Societies not intending to send a team may, instead, invite individuals to compete.

It seems unlikely, however, that the RSGB would consider sending anyone to take part as, in the light of events in the Ukraine, it has decided to exclude Russian Federation and Belarus radio



6b

amateurs from any of its competitive activities. However, the IARU, which has adopted a different stance, remains neutral on the subject, and presumably Russian and Belarus amateurs will be allowed to compete in the 2023 HST championships in the normal way.

Reference

- McElroy, *World's Champion Radio Telegrapher by Tom French W1MQ*. Pub 1993, Artifax Books.
- Meet the Champion* (Harry Turner), *Morsum Magnificat* (MM), Summer 1989.
- New Code Champion! QST*, October 1935.
- Report on the ARRL Speed Contest, Chicago, August, 1933, QST*, November 1933.
- RUFZ program: www.rufzxp.net
- Rules of the IARU HST championships: <https://tinyurl.com/yxohx654>
- Journal of the Telegraph*, March 20, 1886.

Continued from page 61



8

Jim PA3FDR: 7MHz FT8: 9K2YD, KS40T. 10MHz FT8: NP3DM, RVOAPH, UN3P, V31MA. 14MHz FT4: BD6RN, JA6FIO, RVOAPH, VK2LAW, W6ZD, YB9KA. 14MHz FT8: BD6JN, ZL2BX. 18MHz FT4: HC1MD. 18MHz FT8: C31LK, JA1PCM, TY0RU, UA0A, UN0LK, VE6CV, VK2LAW, ZZ5BB. 21MHz FT4: 9K2TV, BG0BBB, HI8S, JA3FQO, SU1AS, YC5YZ. 21MHz FT8: BD3MN, CO8TS, CX1NU, HK5WML, JA7XVZ, LW1DG, PP5SB, YB2JDC, YV5EVA. 24MHz FT4: JG4AKL, PU2TXZ. 24MHz FT8: 9K2YM, AP2TN, JS6SCO, K6EID, LU3VA, PY8WW, TY0RU, UA0APV, VA7QI. 28MHz FT4: PY2FA. 28MHz FT8: VA3MPG, WW1XX.

Etienne OS8D 14MHz SSB: 3V8SS, D4Z, E20AX, FM5BH, HSOZMY, J28MD, UP5B, VL4U, Y11WWA. 18MHz SSB: 3B9FR, 9K2F (AS-118), JR7TKG, P29RO. 21MHz SSB: 9N7AA, BA4TB, D60AE, DS2BZN, E2A, EY8BA, FJ/SP9FIH, FK8GM, JM1XCW, JT5DX, PJ2/ND8L, UN1EAX, V26B, YB2MVD, ZF2PG, ZL1ACE. 24MHz SSB: D60AE, FJ/SP9FIH, J28MD, JA8COE, T02DL, TY0RU, VK2BY, WP3AV, XE1XR, Y11WWA, YV5KG. 28MHz SSB: 3B9FR, 5V7RU, 7Q6M, B7C, BX5AA, CO6HLP, CX1AV, CE1TT, D44PM, D60AE, EK6TA, EY7AD, J28MD, JA3MIX, LU8DPM, NP2J, OX3LX, PJ2T, PJ4G, PY2ERC, TI2CC, TY0RU, TZ4AM, UN8PT, V31XX, V47FWX, V51WW/P, VR25XMT, WP4KJJ, Y11WWA, ZF2MJ.

Carl 2E0HPI: 14MHz SSB: JH1GEX, ZL3CW. 18MHz SSB: AL7KC, KL7SB, WC9G. 18MHz FT8: 5V7RU, TY0RU, VU2FGQ. 21MHz SSB: D60AE. 21MHz FT8: A41ZZ, YD2UED. 24MHz SSB: KB0MPB.

Signing Off

Thanks to all contributors. Please send all input for this column to teleniuslowe@gmail.com by the 11th of each month. For the March issue the deadline is 11 January. 73, Steve PJ4DX. **PW**

Billy McFarland GM6DX
gm6dx@outlook.com

One wire antenna that I have found is under used by many amateurs is the full-wave loop antenna. Plenty of people use multi-band non resonant loops with a 4:1 balun to help with matching but the monoband resonant full-wave loop just seems to go under the radar with many amateurs. The loop has more gain than a dipole and the radiation pattern can vary depending on how it has been positioned and fed. In order to make this loop antenna you will find it beneficial to use an antenna analyser such as the RigExpert AA55 Zoom or 230 Zoom (or similar).

Construction

You will need a few components:

- 1 x dipole centre (allows wire connections to a SO239 connector)
- 1 x length of 75Ω coax (I use Van Damme RG11)
- 1 x length of multi-stranded copper wire (auto wire 2.5mm from eBay works well)
- 2 x PL259 plugs for 10mm coax (to fit to the Van Damme RG11)

The loop antenna when resonant has a feed-point impedance of around 110Ω. This means that when the loop is cut to the resonant frequency it would give an SWR of around 2:1. In order to match the transceiver's 50Ω output to the antenna's 110Ω we will need to create a quarter-wave matching section of 75Ω coax, such as RG11. I am sure you will recall from your amateur radio studies the explanation and formula of how to calculate the needed coax impedance when you know the input impedance (50Ω) and required output impedance (110Ω). If not, don't worry there are plenty of online calculators such as the one found here:

www.qsl.net/w4sat/qtrwavtr.htm

You can take my word it, that for a full wave loop antenna, a quarter wave of 75Ω coax will work perfectly. Before we work out the length you will need to know the velocity factor of the 75Ω coax. For the RG11 Van Damme coax it is 85% but you must check the manufacturer's or supplier's website for this information. The calculation for the length of quarter wave coax is:

$300/f \text{ MHz} = \text{wavelength}$, so $300/18.1\text{MHz} = 16.57\text{m}$. This is the full wavelength but we need a quarter of a wave, so $16.57/4 = 4.14\text{m}$.

Take this quarter wave figure of 4.14m and multiply it by the velocity factor of the coax to get the final length. $4.14\text{m} \times 0.85 = 3.519\text{m}$ that is from the tip of one PL259 to the other PL259. This will be the total length of your 75Ω matching section that will connect from the feedpoint of the loop to your 50Ω coax, which goes to your transceiver. If this seems brain frying, then there is an online calculator here, which will help you out:

www.qsl.net/w4sat/velfact.htm



Loop the DX

Billy McFarland GM6DX advocates the use of a full-wave wire loop antenna.

The photo, **Fig. 1**, shows the PL259 fitted to the 75Ω coax. To accurately check this length use your antenna analyser. For the RigExpert you select:

SETUP > SYS IMP and select 75Ω
SET UP > CABLE VEL. FACTOR and change to 0.85

This is the analyser now correctly set. Simply connect coax to the analyser and then go to: TOOLS > STUB TUNER and scan.

This will show a quarter wave and half wave frequency of the coax that you have attached. It will also show if the coax is an open or closed circuit. If your coax is too long, then simply trim one end until you get it to as close as 18.1MHz (or whatever frequency you are using) as possible. If you trim this, then you will need to refit the PL259 plug to that end. Alternatively, just fit one PL259 plug, trim using the analyser then fit the second PL259 afterwards. **Fig. 2** shows the stub tuner in action with my loop used in this article. Once you are happy with the length of matching coax then connect it to the dipole centre. I like to place some heatshrink over the connections before I make use of weatherproof tape. On your dipole centre make up two small wire loops and connect these to the bolts on the dipole centre. This will allow you to attach the full-wave wire loop easily during tuning, all this can be seen in **Fig. 3**. Before we proceed any further ensure that you have reset your analyser to 50Ω impedance for antenna tuning (SETUP > SYS IMP and select 50Ω).

The next calculation is for the length of the

wire that will make up the full-wave loop. The common formula for the loop is:

$306 / f \text{ MHz} = \text{length of loop}$ > $306 / 18.1\text{MHz} = 16.9\text{m}$

You will note that it is slightly longer than the calculation used for the full-wave figures. You can of course use an online calculator rather than trusting your mathematics. Such a calculator can be found here:

<https://tinyurl.com/48mmrx4>

Measure out some wire and trim at 17m long (this allows some extra for tuning). I like to mark out 1m lengths along the garden fence and simply hold the wire up until the total length has been reached before trimming.

Tuning

Now we have our wire and feedpoint complete it is time to get some tuning done. First, strip and twist connect the 17m loop to the dipole centre as seen in **Fig. 4**, solder one side and make the remaining side a temporary fixing for tuning. Suspend the wire in the shape that you would like it; square or triangular are the most common. Ensure the wire loop is supported or guyed using strong non-conductive material and hung in position as seen in **Fig. 5**. Lawnmower pull starter cord is one of the best options to use for guying. Once the antenna is supported in its final shape then connect your antenna analyser. Set the frequency of the analyser to 18.1MHz and scan. If the dip in the analyser is too low as seen in **Fig. 6**, then simply keep trimming the wire, re-attaching to the dipole centre on each occasion and scan. Remember 'the lower the frequency the longer the antenna'. Follow the

Fig. 1: The PL259 connector on the 75Ω coax.

Fig. 2: Checking out the stub tuner.

Fig. 3: Preparing the feedpoint to accept the loop.

Fig. 4: One end of the loop connected temporarily during tune-up.

Fig. 5: The loop installed ready for measurement.

Fig. 6: Tuning too low.

Fig. 7: Now resonant in band.

Fig. 8: Possible loop configurations.

same process until you get a nice dip in the middle of the band as seen in Fig. 7. This completes the antenna tuning process. Now it is just a case of soldering the wire connections to the dipole centre and installing it in the permanent location. If you don't have access to an antenna analyser, then provided you stretch out the 75Ω coax and cut it to the calculated length you will be able to tune the loop using an SWR meter. I have found that the theoretical length of matching coax is pretty much bang on the length needed so trimming the loop to length can be achieved by use of an external SWR meter.

Using the Antenna

As already stated, the orientation of the loop will determine in which way the radiation will leave the antenna. With use of Fig. 8 as reference the triangle loop (delta loop) has numerous positions in which it can be hung vertically and fed. Options A and C will give a high to very high radiation angle and a horizontal polarisation. Option B will give a high radiation angle and horizontal polarisation. Option D is a low angle of radiation with vertical polarisation meaning this option is likely to be the best for DX contacts. If using a square loop horizontally, I have found that feeding it in the corner works best.

This antenna is a great monoband low noise antenna, which can be used in the portable or home setting. It does not require a lot of materials to get working and construction is very simple even when using basic equipment. You can see my video of the loop construction here:

<https://tinyurl.com/mrxedjtw>

Give it a go and work the DX. If you have any questions of any part of the process, then drop me an email at

gm6dx@outlook.com

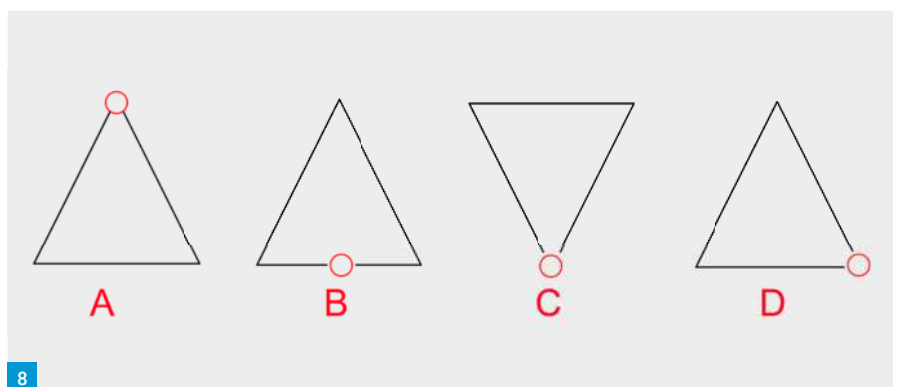

Read more radio news and reviews at www.radioenthusiast.co.uk/news

Keith Rawlings G4MIU

keith.g4miu@gmail.com

Hi everyone and welcome to the new *PW* 'antennas' column. Many of you may know me from *RadioUser* where I ran the monthly *Aerials Now* column. For those that don't, I was first licensed as G8MCK in September 1976. In 1981 I took the then Post Office Morse test to become G4MIU.

I have a background in antenna manufacturing and mobile radio systems and have also written various articles and equipment reviews for *RadioUser* and the *World Radio TV Handbook*, not to mention book reviews for *PW*.

My main amateur radio interests currently lay in HF operating although, rather ironically, I presently do not have any suitable antennas up for transmitting due to some ongoing tree work in my back garden!

I do at least have a couple of HF receiving antennas, a 66ft Inverted-L End-Fed and a homemade 'Wellgood' active loop. For VHF/UHF a Diamond V2000 is presently located in the attic until it is restored to its rightful position outside. Hopefully I will have something capable of being used for transmitting up in the air sooner rather than later.

In this column I very much hope to cover any and all topics related to antennas, including design, construction, 3D printing, antenna simulation/modelling, news and reviews. Anything that can be found in the line from the antenna right up to the socket on the radio will be fair game.

I also very much hope you will share your ideas, tips and tricks with me in the column as every day there seems to be something new to learn on this fascinating subject.

Background

When compiling my columns I tend to rely heavily on computer modelled polar plots to demonstrate predicted antenna patterns, always remembering that these are just simulations and that in the 'real world' things may be different for various reasons.

Computer Modelling.

It might be a good idea to start off with describing the software I will use for generating graphics.

Like many, I started off learning to model antennas by using ELNEC and then EZNEC.

The 'basic' EZNEC was/is a front-end for the NEC 2 calculating engine, which is based on the Method of Moments (MoM) technique. Incidentally the NEC code was originally written in Fortran the 1970s by **Gerald Burke** and **Andrew Poggio** of the Lawrence Livermore National Laboratory (LLNL) in the USA. The code was made freely available for general use and quite naturally made its way onto the PC platform, EZNEC being just one such case. More recently

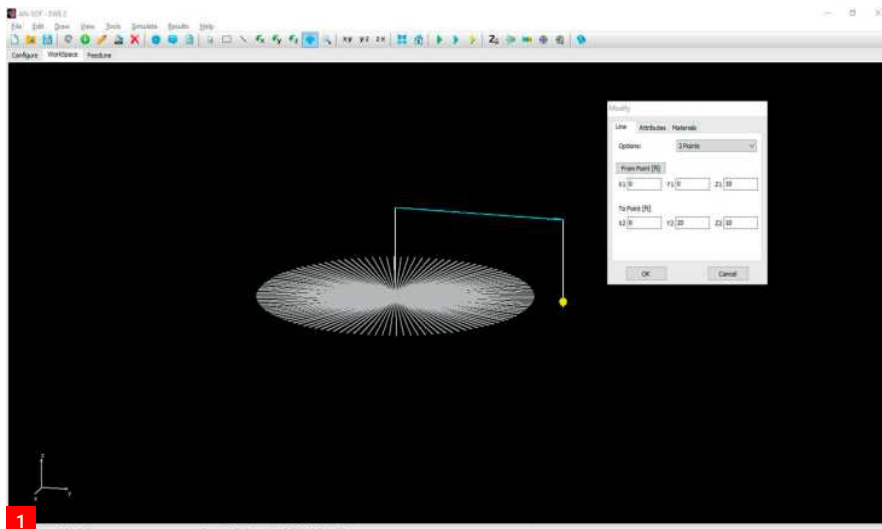

Antenna Modelling

We welcome **Keith Rawlings G4MIU** as a new regular columnist on the important subject of antennas.

Gerald Burke also produced NEC 5 just before passing away.

Originally, the professional Pro/2 version of EZNEC was quite expensive with the Pro/4 and additional, but more capable, NEC 4 engine even more so. I continued using EZNEC+ running NEC2 and a few years ago, I had brought to my attention a software package called AN-SOF. This was running on Version 3 at the time and what attracted me to it was its ability to provide colour 3D graphics, ease of use and its claim of using 'Conformal Method of Moments' (CMOM).

AN-SOF state that CMoM gives benefits over MoM: "Conformal segments are used that exactly follow the contour of the structure, obtaining an exact description of the geometric details.

"All the limitations of the traditional MoM are removed by treating the so-called Kernel of the integral equation exactly, unlike other software packages that use thin-wire approximations. AN-SOF is the only software on the market that has a calculation engine based on the CMoM.

"Using conformal segments, the number of calculations is reduced and accuracy is greatly increased.

"Simulation time and computer memory space are also reduced, allowing for the solution of bigger problems.

"Advanced calculation techniques are implemented in the CMoM, making possible simulations from extremely low frequencies (electric circuits at 50-60Hz) to very high ones (microwave antennas at 2.4/5GHz).

"This extended frequency range is only available in AN-SOF."

After reading this sales 'blurb' I just had to

download the evaluation version and then, being suitably impressed after a few weeks use, I bought the full Pro version, especially as at the time I found out there was a special offer running on it! I was then very pleased when I was able to quickly put the software to good use to supply some 3D colour plots to one of my customers to send on to their customer!

It wasn't just the graphics and charting options that stood out with the software. It was its ability to model wires close to or on ground, capability to import NEC and EZNEC files, the ability to simulate different materials on individual 'wires' and also to simulate patch and micro-strip antennas.

AN-SOF now has a very useful Feed-Line tab-sheet where a transmission line used to feed an antenna can be modelled, and an online Knowledge-Base is now available, which is extensive and very informative.

The simulator is being continually updated so when I started *Aerials Now*, AN-SOF seemed the obvious choice to use for plots and diagrams as well as for my day to day modelling.

Aimed at both the professional and amateur there are various purchase options available as well as a fully functioning 'test' version, the only limitation being 50 segments still making it 'good' for many designs. See links below*.

Other Packages.

Readers who are interested in antenna modelling may well be thinking 'free' to use. Three packages that act as front ends to NEC and are free immediately come to mind: MMANA-GAL, 4NEC2 and EZNEC.

Sign up to our FREE email newsletter at www.radioenthusiast.co.uk

Fig. 1: AN-SOF CAD Design Window.

Fig. 2: AN-SOF 3D EWE Power Density Plot.

Fig. 3: AN-SOF 2D EWE Directivity Plot of

Elevation Top and Azimuth Below.

Fig. 4: AN-SOF EWE SWR Graph.

Fig. 5: EZNEC Layout View.

Fig. 6: EZNEC EWE SWR Graph.

Fig. 7: EZNEC Smith Plot.

MMANA-GAL has a huge following and a great deal of support although it does have some limitations. Usefully it has an Optimiser where models may be optimised to specifications set by the user. For example, maximum forward gain, best front-to-back ratio, lowest SWR and so on. EZNEC and AN-SOF do not have optimisers although EZNEC can be 'Automated' by using Dan Maguire AC6LA's AutoEZ and AN-SOF can use the free app called Scilab to automate models. A great choice, MMANA-GAL uses the MININEC-3 engine, which has been modified by Alexandre Schewelew DL1PBD, and is written in C++.

4NEC2 is an excellent package although I know that some have found difficulty using it. Had I not already invested years of time learning to get the best out of EZNEC and AN-SOF, then I guess that 4NEC2 would have been my tool of choice. It has (like all of the packages here) many features, including an optimiser, and like MMANA-GAL and EZNEC uses a spreadsheet method of data entry. (AN-SOF has a similar method of entry but works/edits on a single wire at a time.) It runs the NEC 2 engine but I believe it will also run the NEC 4 engine and I have seen claims that it also runs NEC 5.

EZNEC Because I had learnt a lot about EZNEC and because I had paid for it, I still continued to use the package. It has a great following and there are many readily available models online that can be added to those supplied.

From the beginning of 2022 Roy Lewallen W7EL, the author of EZNEC, retired and made EZNEC free to use by releasing EZNEC Pro/2+ v.7.0. This was a bit of a game changer as some relatively expensive software was now free and, what was more, LLNL had already released NEC 5 at \$110 for individual users and EZNEC would be made compatible with it. NEC 4, which is still available I understand, was a lot more expensive and still needed the purchase of the appropriate version of EZNEC to run it which, at the beginning of 2022 became unavailable.

With EZNEC Pro becoming available for free and being able to run the NEC 2 and NEC 5 engines, the latter of which I had already purchased the licence for, I decided it would be worth the investment to purchase the application called AutoEZ. This is a spreadsheet package written by Dan Maguire costing \$79. It automates and increases the versatility of EZNEC "by allowing the use of variables in place

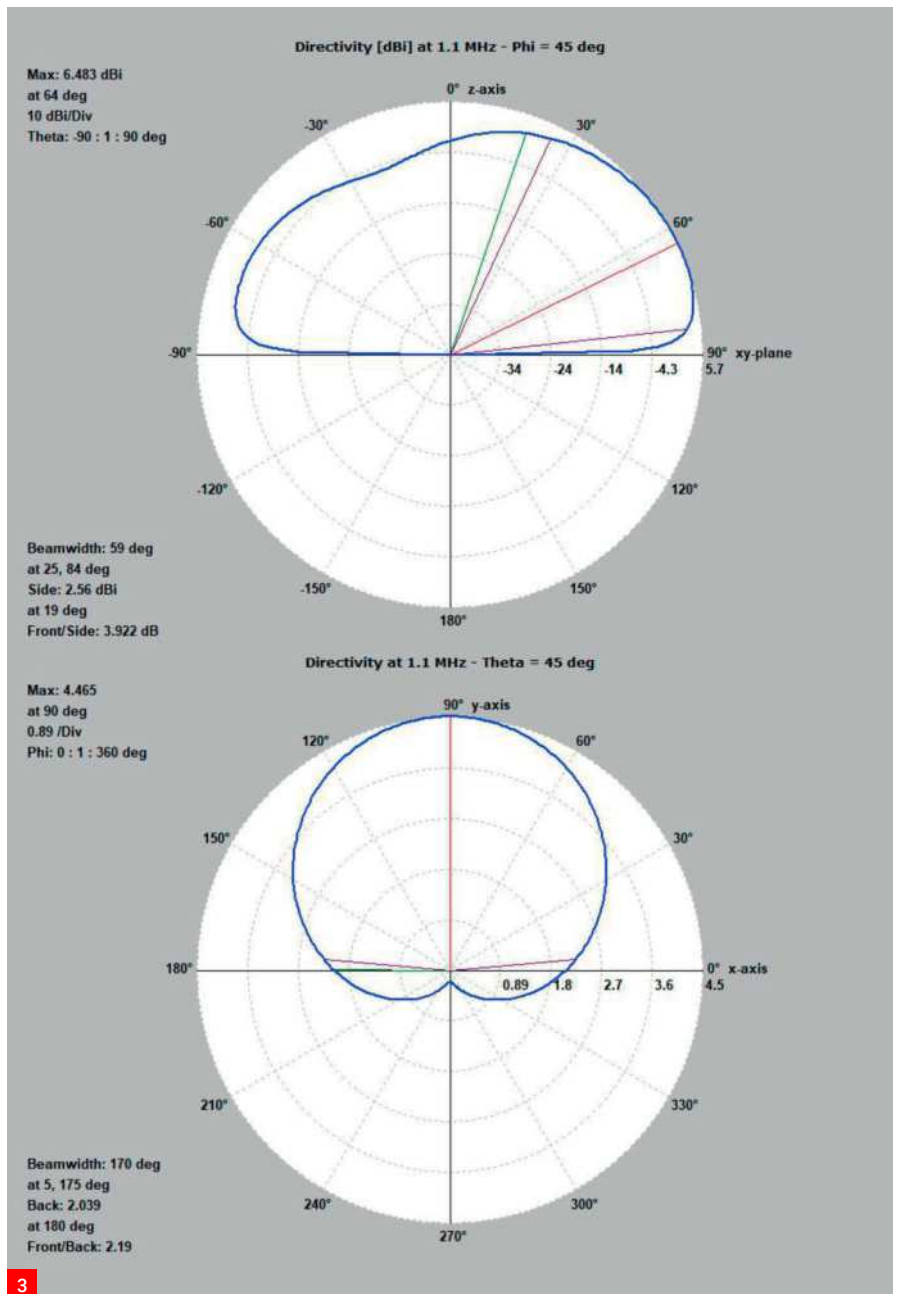
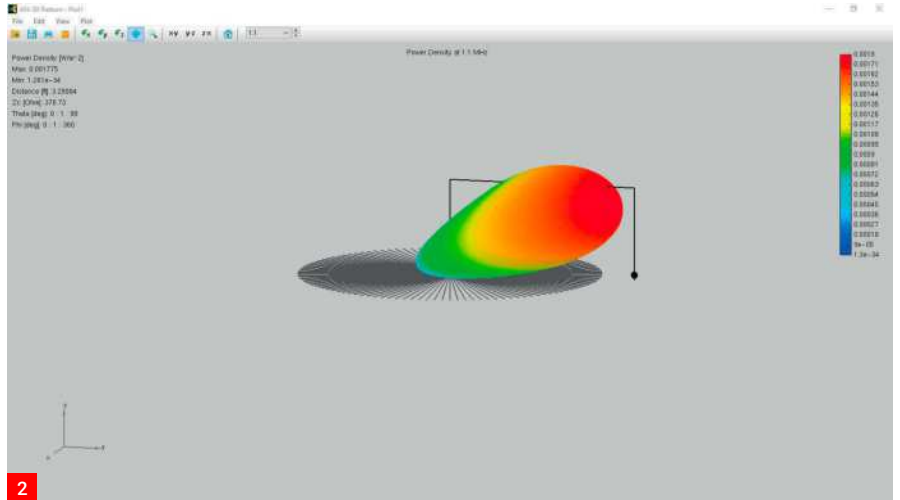

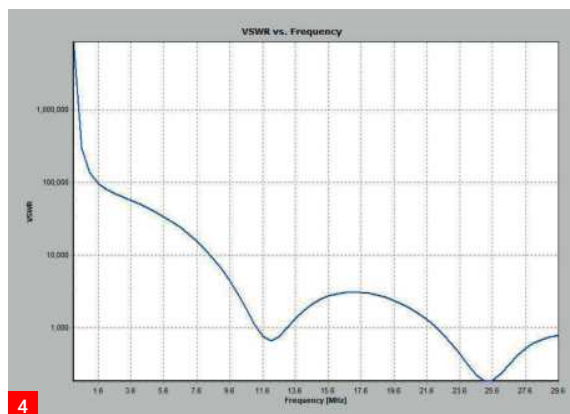

4

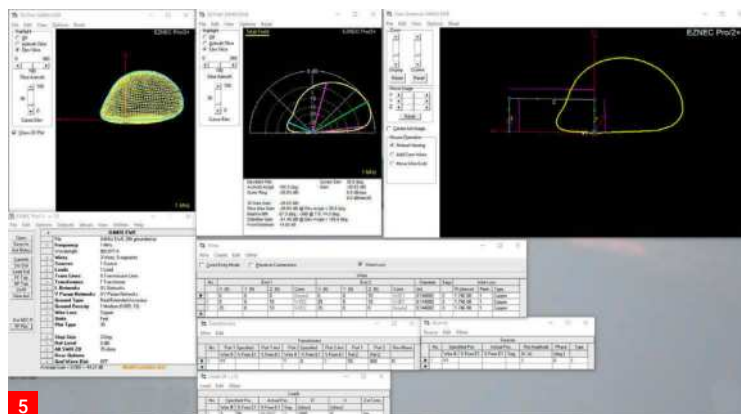

5

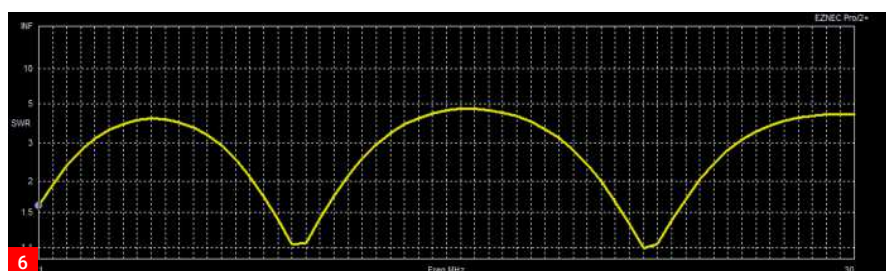

6

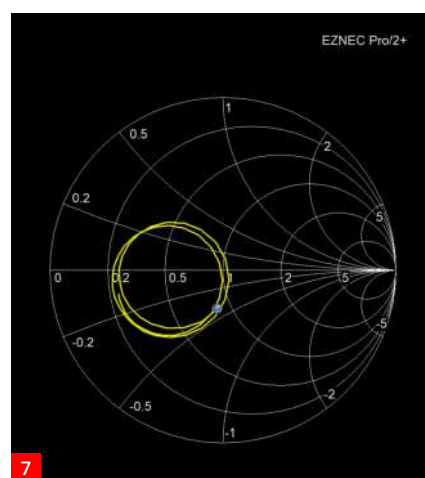

7

of or in addition to any numeric value found in any part of EZNEC". It can also be programmed to optimise a design, add stepped diameters to Yagi elements, model complete systems including tuners and transmission lines plus a lot more. It is, in my opinion, well worth the money to get the very best out of EZNEC Pro.

Roy Lewallen and Dan Maguire are also responsible for rectifying some known bugs left in NEC 5 after Gerald Burke's death.

Incidentally existing models that have been made with NEC2 or NEC4 will need to be modified if used with NEC 5 due to a change in the way the engine handles sources.

I will use AN-SOF and also EZNEC in the column as the latter is now free.

Newcomers to Modelling.

I expect there are some who are not familiar with antenna modelling, so, here is a very brief and basic description of what is involved using AN-SOF and EZNEC and why me might want to simulate in the first place.

When building a model the packages mentioned all have one thing in common. The antenna dimensions and height are entered, how it is fed (sources), any loads and transmission lines, construction materials, any wire insulation added and, importantly, the ground beneath is included.

The simulation is run and then the data is extracted from the software, and how this is done varies from package to package.

AN-SOF, for example, uses a familiar looking CAD 'Windows' user interface and requires that the simulation is run first. Once run, results are presented by selecting any of the (considerable)

number of options. Results are displayed in separate dedicated application windows, the number of which is unlimited. These remain unchanged even after re-running a simulation and also after closing the simulator. **Fig. 1** demonstrates the AN-SOF design page where an EWE receiving antenna is going to be simulated. **Fig. 2** is a 3D Power Density plot of the EWE at 1.1MHz and **Fig. 3** shows 2D Directivity plots of Elevation top, and Azimuth bottom with **Fig. 4** demonstrating an SWR plot.

EZNEC has a different approach in that the main user interface has a number of buttons, which are used to open up spreadsheet style tables to enter data or run individual simulations.

Fig. 5 shows a typical EZNEC page layout of the same EWE design. Clicking on the FF button displays the Far Field plot of an antenna at the selected frequency where plots may be Azimuth, Elevation or '3D'. When 3D is displayed 2D plots may also be displayed in separate windows. A 3D and also a 2D Elevation plot may be seen in **Fig. 5** along with an 'Antenna View' window. **Figs 6** and **7** Are EZNEC plots for SWR and Smith Chart respectively.

By modelling we can try to design better antennas and be able to predict their performance. We can repeatedly 'tweak' a design for optimum results before building a real model, and evaluate existing designs to see if they meet our requirements and alter them if they don't!

A good example of this was seen in the November 2022 edition of *PW* where **Mark G7LSZ/SA6BID** used 4NEC2 to evaluate his 'German Quad' before building. We can also use modelling as a learning tool to see how antennas work.

Links

- AN-SOF
<https://tinyurl.com/a7ab4f6r>
- The users guide can be found here:
<https://tinyurl.com/2vytmc83>
- The superb Knowledge Base may be found here:
<https://tinyurl.com/4ewuvsh8>
<https://tinyurl.com/4eddfitj>
- EZNEC
www.ez nec.com
www.ez nec.com/AutoEZ.htm
- AutoEZ
<https://ac61a.com/autoez.html>
- MMANA-GAL
<http://gal-ana.de/basicmm/en>
<http://gal-ana.de/promm>
- 4NEC2
www.qsl.net/4nec2

All of the above packages are capable of providing surprisingly accurate results as long as care is taken when designing the model and bearing in mind any nearby objects that may affect a real world antenna. EM Software that simulates nearby objects accurately can be expected to come with an eye watering price.

That's all for this month! **PW**

Sign up to our FREE email newsletter at www.radioenthusiast.co.uk

Keith Hamer

Keith405625.kh1@gmail.com

Garry Smith

Garry405625.gs@gmail.com

In October 2022, the BBC celebrated their Centenary. The BBC was originally a limited company, formed on 18 October 1922. Initially, the British Broadcasting Company raised funds to begin their service by issuing shares, **Fig. 1.** Daily broadcasting began from the London 2LO station on 14 November.

Several restrictions were imposed upon the BBC by the Postmaster-General. For instance, the source of news items was strictly controlled. The BBC were not allowed to set up a news service of their own, even if the terms of the regular agencies became too onerous. They were also not allowed to broadcast 'running commentaries' on ceremonies, gatherings and sports events. The publishing of magazines and books by the BBC was also tightly regulated. When the Company and the well-known publishers, Newnes, jointly started publishing *The Radio Times* in September 1923, the existing producers of radio schedules felt their interests were being challenged by a journal that enjoyed an overwhelming advantage in its monopoly of printed programme guides. Some argued that the business of a broadcaster was simply to broadcast, and that any publishing was outside the BBC's legitimate sphere. Countering this view, the BBC maintained the position that such publications were a proper and necessary supplement to their broadcast programmes. However, as a rather obscure concession, the BBC agreed not to publish any technical articles and all advertisements for component parts for equipment were rejected.

The BBC's income was fixed by the Postmaster-General at 75% of the revenue from listeners' licence fees, without subsidy from the radio trade, or in fact any ancillary sources except profits from publications. The first broadcast receiving licence was introduced on 1 November 1922, and cost 10 shillings (50p).

Most of the restrictions outlined above were removed when the BBC became the British Broadcasting Corporation and constituted under Royal Charter on 1 January 1927.

Daily broadcasts from the London station, known as 2LO, began on the evening of 14 November 1922.

The first BBC transmitter was installed at Marconi House, London. It was the first of a number of 1kW transmitters each located near the centre of the town. More spacious accommodation was soon required and in 1923, the head office and London studios moved to Savoy Hill. In 1925, a 2kW transmitter was installed on the roof of Selfridge's department store in Oxford Street.



The Vintage Days of Radio

Welcome to this new column where we will be featuring milestones in television and radio history, personalities, landmark programmes, and engineering achievements from a bygone era. This month we look at the start of the BBC, short-wave radio experiments, a vintage 1927 advertisement for equipment, Marconi's connection with Bournemouth, secret BBC studios, the Swiss Beromünster transmitter, and early television pioneers.

BBC Short-Wave Experiments

In his original radio experiments, German physicist **Heinrich Rudolf Hertz** used short waves, namely waves of only a few metres in length. Subsequent experimenters followed him, and it was found that these waves quickly became attenuated as they travelled away from their source over the Earth's surface. It was later discovered that the attenuation was reduced as the wavelength was increased.

In the race for long-distance transmission, wavelengths were increased. In the early 1920s, the transoceanic telegraph services used wavelengths in the order of 10,000 to 20,000 metres. An increase in wavelength also involved a corresponding decrease in frequency of the oscillations. An immense amount of work to investigate short-wave propagation was carried out by the BBC to look into the possibility of

transmitting programmes around the globe.

An experimental interchange of programmes between the UK and the USA was successfully carried out in 1927, a short-wave wireless link across the Atlantic being used for relaying the American programmes to England.

However, BBC engineers were not fully aware of its possibilities, being somewhat inclined to leave it to 'amateur' enthusiasts. That was just as well, perhaps, because the short-wave transmitting amateurs in their enthusiasm were not long in proving to the official broadcasting authorities, and to the professional radio fraternity throughout the world, the great advantages inherent in the use of short waves as a means of transmission and reception of telephony and telegraphy over great distances. The enthusiastic band of amateurs were thanked in 1927 for the great improvement in short-wave apparatus due

Read more radio news and reviews at www.radioenthusiast.co.uk/news

Fig. 1: A 10-shilling broadcast receiving licence was introduced on 1 November 1922.

Fig. 2: An advertisement published in 1927 for the Ormond 5-Valve Portable Set featuring switching between short and long wavebands.

Fig. 3: Madeira House, Bournemouth, in 1871.

(Photo: Keith Hamer and Garry Smith/Court Royal)

Fig. 4: The last vestige of Marconi's mast in Bournemouth.

Fig. 5: Marconi's laboratory (lower left), now used as a storeroom at the Court Royal Convalescent Home for Welsh miners.

Fig. 6: Confirmation, signed by George Kemp, that signals using Morse Code had been successfully transmitted from Bournemouth to the Isle of Wight on 3 March 1898.

to the elimination of some features of design and construction that only two or three years earlier had led to considerable losses in signal quality.

The amateur enthusiasts studied the problem of aerials for short-wave work and introduced economic, and thoroughly successful, aerial systems for long-range operation. Even less-skilled amateurs who had been content to construct various sets for listening-in to broadcast programmes had played their part towards improving the quality of reproduction.

Because no suitable landlines could be provided by the Post Office, the first operas broadcast from the Old Vic in Waterloo Road, London, were relayed to 2LO by a short-wave transmitter. Such were the difficulties confronting the early broadcasters.

Vintage Wireless Equipment

While meandering through vintage copies of deserted newspapers and magazines, the authors discovered an advertisement for the Ormond 5-Valve Portable Set featuring switching between short and long wavebands, Fig. 2. In the 1920s, an additional 'Royalty' fee had to be paid on certain equipment! The text has been left in its original format to reflect the spelling and punctuation of the time.

This is the full description of the equipment featured in the advertisement, dated 1927:

"This set is ideal for indoor and outdoor use. It is contained in a Handsome Mahogany Cabinet, is extremely simple to control, and will render perfect reproduction under average conditions from a main B.B.C. Station within about 30 to 40 miles, and about 400 miles of Daventry.

A simple switch gives choice of short and long wavebands. Entirely self-contained and is fitted with a Celestion Loud Speaker. Complete with all Accessories and ready for immediate use.

Price £24 10 0

Marconi Royalty extra £3 2 6

In addition to the 5 valve Portable Set,

Ormond Manufacture 2 and 3 valve Sets, Also, Condensers - Logarithmic S.L.F., Square Law, 2, 3

The ORMOND 5 VALVE PORTABLE SET



This set is ideal for indoor and outdoor use. It is contained in a Handsome Mahogany Cabinet, is extremely simple to control, and will render perfect reproduction under average conditions from a main B.B.C. Station within about 30 to 40 miles, and about 400 miles of Daventry.

A simple switch gives choice of short and long wavebands. Entirely self-contained and is fitted with a Celestion Loud Speaker. Complete with all Accessories and ready for immediate use.

Price = = = **£24 10 0**

Marconi Royalty extra - - - - **£3 2 6**

BAKELITE MOULDINGS

Quotations given for Bakelite Mouldings of every description, for which enquiries—large and small—are invited.



In addition to the 5 valve Portable Set, Ormond Manufacture 2 and 3 valve Sets. Also, Condensers—Logarithmic S.L.F., Square Law, 2, 3 and 4 Gang Models, etc., etc.

199-205 PENTONVILLE ROAD, KING'S CROSS, LONDON, N.1

Telephone: Clerkenwell 9344-5-6. Telegrams: "Ormondengi, Kincross."

FACTORIES: WHISKIN ST. & HARDWICK ST., CLERKENWELL, E.C.1

Continental Agents: Messrs. Pettigrew & Merriman Ltd., "Phonos House," 2 and 4, Bucknall Street, New Oxford Street, London, W.C.1

and 4 Gang Models, etc., etc

Bakelite Mouldings

Quotations given for Bakelite Mouldings of every description, for which enquiries - large and small - are invited.

199-205 Pentonville Road,

King's Cross, London, N.1

Telephone: Clerkenwell 9344-5-6. Telegrams:

'Ormondengi, Kincross.'

Factories: Whiskin St. & Hardwick St.,

Clerkenwell, E.C.1

Continental Agents: Messrs. Pettigrew &

Merriman Ltd., 'Phonos House,' 2 and 4, Bucknall Street, New Oxford Street, London, W.C.1"

Marconi In Bournemouth—Part 1

While nursing a pint in a well-known chain of hostels in Bournemouth, noted for their below-average prices, the authors were drawn to a plaque on the wall commemorating experiments conducted by Marconi in that town and beyond. He lived at Madeira House, which today is known as Court Royal. Intrigued by Marconi's connection with Bournemouth, the authors paid a visit in October 2022 and were given special access to roam around the private residence, which is now a beautifully decorated convalescent home for Welsh miners, located on South Cliff Road, close to the Bournemouth International Conference Centre.

Sign up to our FREE email newsletter at www.radioenthusiast.co.uk

Although a small museum inside the home was planned some years ago, this never came to fruition. Likewise, a proposed book didn't materialise. However, there are some very interesting items and photographs at the home, which the Manageress very kindly shared with the authors. Some of them are featured in this article.

Marconi At Madeira House

Guglielmo Marconi was born on 25 April 1874. He left his home city of Bologna due to his frustration with the Italian Ministry of Posts and Telegraphy. Marconi's offer to develop his experiments with electromagnetic waves and a system of wireless communication was rejected by the government. In 1896, at the age of 22, he decided to take all his technical know-how to England. He initially settled in London.

In 1897, he travelled to the Isle of Wight with his assistant, **George Kemp**, where he established his first permanent wireless station at the Royal Needles Hotel.

Fortunately, George Kemp kept detailed accounts of their experiments. On 24 November 1897, they went to Southampton and purchased a steam yacht. On 7 December, their experiments began in earnest when they made daily round-trip sailings from the Isle of Wight to Bournemouth Pier and Swanage Pier, noting the various signal strengths. Despite gale-force winds and torrential rain, good progress was made. Signals were received at distances up to 18 miles (29km). By 23 December 1897, they were confident that a station could be installed in Bournemouth and another at Swanage.

In January 1898, he set up a station at the hotel, *Madreia House*, not far from Bournemouth Pier. The original hotel is shown in **Fig. 3** (second building, top-right). The photograph dates from 1871. His ambition was to transmit a signal from his new station to Swanage on the west and the Isle of Wight to the east, or to ships at sea. A mast was erected and a wire ran down from the top to apparatus in a room where all his equipment for receiving and transmitting messages was housed.

The instruments appeared to be relatively simple and could be accommodated on a very small table. Sadly, the one and only vestige of Marconi's endeavours at the hotel is a short rusty piece of the mast and a small, weather-beaten and totally undecipherable plaque, **Fig. 4**. Marconi housed all his receiving and transmitting apparatus in a shed at the bottom of a spacious garden. Nowadays, this historic outbuilding is used merely as a general storeroom for items no longer required inside the home. His former laboratory can be seen immediately to the left of the lamppost in **Fig. 5**.

Following some initial technical problems, Marconi gave a series of successful



demonstrations from the Royal Needles Hotel to Madeira House on 9 January 1898, in the presence of directors from his company, *The Wireless Telegraph & Signal Company*, and several influential local residents.

On 3 March 1898, signals using Morse Code were successfully transmitted from Bournemouth to the Isle of Wight. Confirmation of this is contained in a document signed by George Kemp. The message reads: "Signals received at the Royal Needles Hotel from Madeira House, Bournemouth on March 3rd 1898 by Marconi's System of Wireless Telegraphy (Signed.) G.S. Kemp", **Fig. 6**.

Marconi's First Commercial Message

Three months later, on 3 June 1898, the prominent Scottish engineer, mathematician and physicist, **William Thomson** Baron Kelvin of Largs, visited Marconi's station and sent a message to **George Stokes** from the Isle of Wight to the receiving site in Bournemouth. Kelvin paid Marconi the princely sum of one shilling (5p) as royalty payment and became the first person in the world to send a commercial message by wireless telegraphy.

Just when everything seemed to be going well for Marconi and Kemp, a disagreement arose with the hotel management over the cost of the 115ft (35.05m) mast that was in the hotel's large garden. George Kemp wrote: "Sept 24th to 28th, trouble with hotel manager Mr. Miller." The equipment was quickly dismantled and two days later, on the 30th, the mast was loaded onto a timber waggon and all the apparatus packed into a van and taken to the Haven Hotel at Sandbanks.

Secret BBC Studios—Part 1

During World War II, it was feared that Broadcasting House in London could come under attack. Indeed, a German bomb did explode in Broadcasting House on 15 October 1940, during the 'live' 9 o'clock News bulletin resulting in seven deaths. Later the same year, on 8 December, a land-mine severely damaged



the building. On 19 November 1940, the radio transmitter located in Birmingham was destroyed by enemy action and on 21 February 1941, the BBC premises in Swansea were severely damaged by bombs.

Not surprisingly, the decision was made to move staff and programme production away from London to the relative safety of Bristol. In the event of an attack, several rooms were built into the defunct Clifton Rocks Railway tunnel to provide control and studio facilities. The new base was affectionately known as the 'Fun Factory'. Radio programmes such as the comedy 'ITMA' (*It's That Man Again*) and 'Bandwagon', featuring **Arthur Askey**, were produced in Bristol.

A water-powered funicular service was originally designed to take visitors down to the Clifton Rocks Railway, and opened in 1893. Unfortunately, it closed in 1934 due to dwindling interest by the public. There is still evidence of the entrance, which can be seen when driving along the A4 from the Clifton suspension bridge towards the city.

Read more radio news and reviews at www.radioenthusiast.co.uk/news

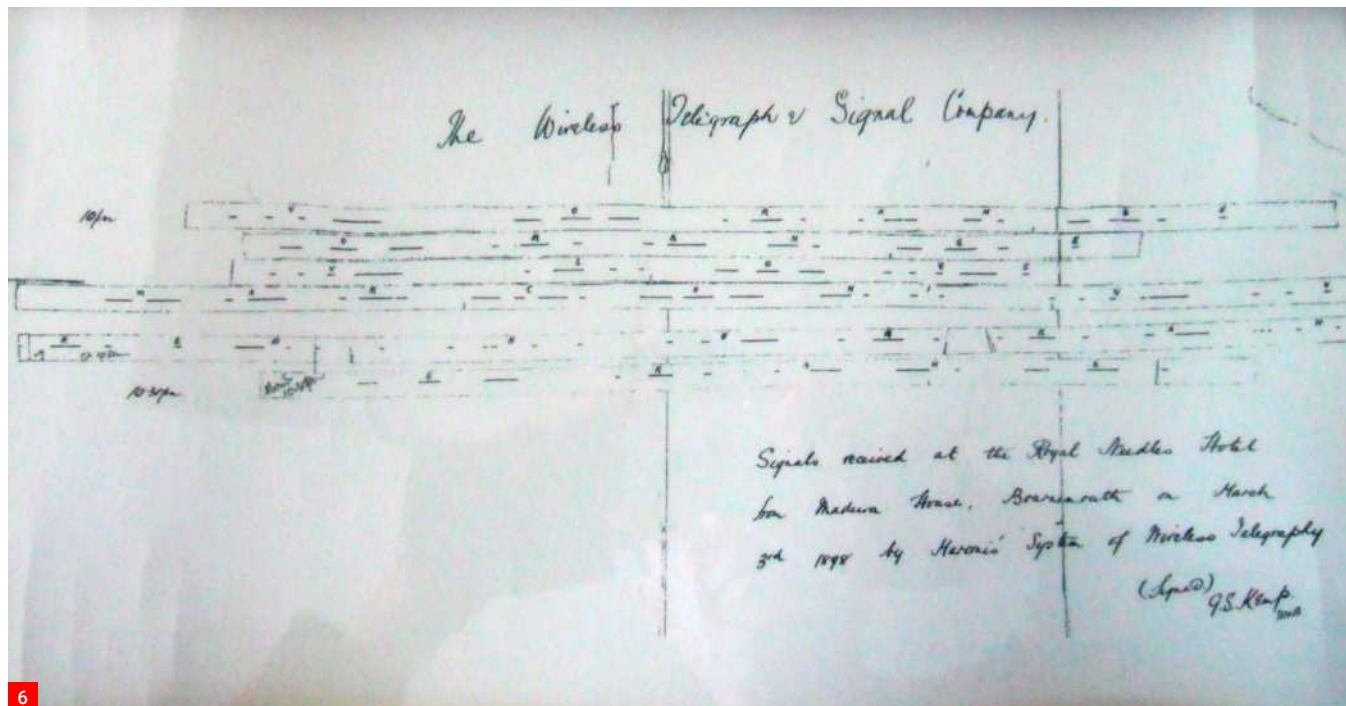

6

When the BBC moved in, rooms were fully kitted out and even made gas-proof in case of an attack. Everything was as up-to-date as possible. Today however, anyone descending the 316 steps to look around the historic site will find that the rooms are in a rather dilapidated state.

Swiss Beromünster Transmitter, 90th Anniversary – Part 1

Swiss radio enthusiasts are set to remember the 90th anniversary of their much-loved Beromünster transmitter, located in Kanton Luzern. The medium-wave AM station (also known as the *Blosenbergturm*) started broadcasting on 1 May 1931, via a 215m self-supporting tower.

The transmitter originally had a power of 60kW and a frequency of 556kHz (539.6m). In 1933, the power was increased to 100kW. A new anti-fading antenna was installed in 1939. The power was increased to 200kW in 1947.

The installation was a 'self-radiating tower', insulated from the ground, resulting in the whole structure acting as an antenna.

At the time, it was the sixth tallest structure in Switzerland. It had a cabin located at a height of 150m (490ft). This contained a coil for feeding the pinnacle, which was insulated from the rest of the tower, with high-frequency energy. Originally, the tower was used as a dipole antenna, fed from the cabin.

In 1948, as a consequence of the *Copenhagen Plan*, the transmitter's frequency was changed to 529kHz (567.1m). In 1969, a new transmitter capable of 500kW was installed. This was only used on full power at night until 1971, after which this ERP became permanent. From 1966, two 250kW

and one 100kW short-wave transmitters were operating for a number of years from this site.

For several years, beginning in 1968, Beromünster also transmitted on 1562kHz (192.1m). In 1978, because of the *Geneva Plan*, the frequency was changed to 531kHz (565m).

Early Television Pioneers: Vladimir Zworykin – Part 1

A system for transmitting television signals had been proposed, in theory, as early as 1908 by **Alan A Campbell Swinton**. His idea was to use a photoelectric mosaic screen onto which the image of the scene could be focused, the screen then being scanned by cathode rays deflected by a varying magnetic field. Russian-born and naturalised American citizen **Vladimir Zworykin** turned this theory into reality, both in America and in the UK, with the assistance of staff at Marconi-EMI in England.

Vladimir Kosma Zworykin was born in Murom, Russia, approximately 200 miles east of Moscow. There is some confusion as to whether he was born on 17 or 29 July 1888, or indeed on 30 July 1889. In 1915, he married **Tatiana Vasilieff** and had two children, but later divorced and married **Katherine Polevitsky** in 1951.

From 1908, he studied at the Imperial Institute of Technology in St. Petersburg. Between 1910 and 1912, he assisted physicist **Boris Rosing** (who was the director of the Institute's laboratories) with his experiments to invent a television system. The concept of sending images over distances by television had tantalised inventors ever since 1839. **Paul Nipkow** patented his mechanical system in 1884. In 1897, another German, **Karl Braun**, invented the cathode-ray oscilloscope in

which magnetic fields directed rays onto a fluorescent material at the end of a tube.

Hybrid Television System

Eventually, Zworykin and Rosing developed a primitive, but successful, hybrid system consisting of a camera based on Nipkow's mechanical rotating mirror-drum to scan the image and Braun's electronic cathode-ray tube to display the picture. Further improvements to the invention were thwarted by the Russian Revolution. Rosing died in exile and Zworykin made a swift departure to Paris where, in 1912, he studied X-rays and theoretical physics at the *Collège de France*.

He then emigrated to the United States in 1919 and became a naturalised citizen in 1924. In 1920, he joined the *Westinghouse Electric Corporation* in Pittsburgh. He left one year later and began working in Kansas City for the *C&C Development Company*, which had a patent for using high-frequency currents in oil refining. He was hired to test the invention but found that the system didn't work.

Zworykin returned to Westinghouse in 1923, and filed a patent for an all-electronic television system, which employed cathode-ray tubes for both transmitting and receiving the images. Other television systems, such as that of Rosing, relied on mechanical devices employing spinning discs and mirrored drums to transmit and reproduce an image. This system was very similar to that used by our own **John Logie Baird**.

Stay Tuned!

Please send archive photographs, information or suggestions for future topics via the email addresses shown at the top of this column. **PW**

Sign up to our FREE email newsletter at www.radioenthusiast.co.uk

Specialist Dealers

Electronics

10% Discount Code: **PW10**
component test equipment
visit: peakelec.co.uk

PEAK® electronic design ltd

Cap = 21.40µF
ESR = 0.78Ω

test off ESR, low resistance and capacitance measurement with auto

Kit Suppliers

KANGA PRODUCTS

Kangas back!
Come and see our wide range of great value and quality kits for the radio enthusiast

www.kanga-products.co.uk

Scotland

TENNAMAST
Genuine Quality Antennas

Radio Masts | Masts | Boat Cruisers | Trailers

A complete range of Multi purpose Masts
The best of Scottish engineering!

Tel: 01505 503824
www.tennamast.com
sales@tennamast.com

Somerset

LINDARS RADIOS
'A Modern Company With Old Fashioned Values'

USED AMATEUR RADIO EQUIPMENT PURCHASED AND SOLD
www.AmateurRadioSales.co.uk
01935 474265

South Yorkshire

LAMCO **VINE** antennas

LAM Communications Ltd.
5 Doncaster Road
Barnsley
South Yorkshire
S70 1TH
01226 361700
sales@hamradio-shop.co.uk
www.hamradio-shop.co.uk

[B](#) [F](#) [G+](#) [in](#) [T](#) [v](#)

/lamcomms

TO ADVERTISE IN PRACTICAL WIRELESS

Contact Kristina Green
Telephone **01778 392096**
kristina.green@warnersgroup.co.uk

Classified Adverts

Wanted

VINTAGE FIREWORK COLLECTOR. Do not light the blue touch paper and burn British Heritage, private collector will pay cash and collect from anywhere, licensed explosive storage.
Call Tony on **07956 506300**

Repairs

REPAIRS TO RECEIVERS, TRANSMITTERS ETC. New/old, valve/transistor. Call **07903 023437** for details. www.kent-rigs.co.uk

For Sale

CTCSS ENCODER AND DECODER KITS. DTMF kits and modules. Pic development kits. <https://cstech.co.uk>

Valves

VALVES AND ALLIED COMPONENTS? For free stock list and/or advice, Please contact me:
Geoffdavies337@Gmail.com
Telephone **01788 574774**

TO ADVERTISE IN CLASSIFIED ADVERTS
Contact Kristina Green Tel: 01778 392096
Email: kristina.green@warnersgroup.co.uk

DISCLAIMER Some of the products offered for sale in advertisements in this magazine may have been obtained from abroad or from unauthorised sources. Practical Wireless advises readers contemplating mail order to enquire whether the products are suitable for use in the UK and have full after-sales back-up available. The publishers of Practical Wireless wish to point out that it is the responsibility of readers to ascertain the legality or otherwise of items offered for sale by advertisers in this magazine.

TOP PRICES PAID FOR ALL YOUR VALVES, TUBES, SEMI-CONDUCTORS AND ICs.



Langrex
VINTAGE ELECTRONICS

Unit 4, Daux Road, Billingshurst, West Sussex RH14 9SJ
Tel: 01403 785600 Fax: 01403 785656

www.langrex.co.uk



SCAN HERE TO GO TO OUR WEBSITE

SCAN HERE TO GO TO OUR WEBSITE

ITREGENERATION

BUY ALL FORMS OF ELECTRONIC SURPLUS COMPONENTS/I.T TEST EQUIPMENT

LARGE QUANTITIES ALWAYS WANTED

PLEASE FORWARD LISTS TO
Email: frtc@aol.com
Telephone: 07927 807327

Bargain Basement

Wanted

NATIONAL PANASONIC RF3100L DR31 SW/MW/LW/FM Radio in very good condition.
Dick: **07963 319751 DORSET**

CREED 75 MANUAL APPENDIX K. Describes parallel computer interface option. Any legible electronic or paper format (will meet costs).
Godfrey G4GLM: (020) 8958 5113
Email: cgmm2@btinternet.com

TO ADVERTISE IN BARGAIN BASEMENT

Contact Kristina Green
Telephone: **01778 392096**
kristina.green@warnersgroup.co.uk

Bargain Basement adverts cost just £5.00

BY EMAIL Firstly email your advert's wording to kristina.green@warnersgroup.co.uk and then call **01778 392096** to make your payment. **BY POST** Send your advert to: Bargain Basement, Practical Wireless, Warners Group Publications plc, West Street, Bourne, Lincs. PE10 9PH Please write your advert in BLOCK CAPITALS up to 30 words, plus 12 words for your contact details and send it together with your payment of £5 (subscribers can place their advert free of charge as long as they provide their subs number or mailing label). Cheques should be made payable to Warners Group Publications plc, credit card payments also accepted. Advertisements from traders or for equipment that it is illegal to possess, use or which cannot be licensed in the UK, will not be accepted. No responsibility will be taken for errors and no correspondence will be entered into on any decision taken on any of these conditions. The Publishers of Practical Wireless also wish to point out that it is the responsibility of the buyer to ascertain the suitability of goods offered for purchase.

TechnoFix UK

Linear Amp Switching (PTT) Cables

Faster, safer Tx/Rx switching for your amplifier.
Selected cables with opto-isolation.
Automatic band switching cables for SPE and Acom 'S' amplifiers.

For these and other great items go to
technofix.uk or www.technofix.co.uk

Rallies & Events

All information published here reflects the situation up to and including **21st November 2022**. Readers are advised to check with the organisers of any rally or event before setting out for a visit. The Radio Enthusiast website www.radioenthusiast.co.uk has the latest updates, please check it regularly. To get your event on this list, e-mail the full details as early as possible: wliessala@hotmail.com

27 November

BISHOP AUCKLAND RAC RALLY:

Spennymoor Leisure Centre, High St, Spennymoor DL16 6DB: Radio, old and new, computers & electronics. The rally takes place in a large ground-floor hall. Doors open at 10.30 am (10 am for disabled visitors). Admission is £2 - under 14s free of charge with an adult.

(BB | CR | D | FP | TS).

07710 023 916

g4ttf@yahoo.co.uk

29 December (Thursday)

YEovil ARC RALLY: Davis Hall, Howell Hill, West Camel, Yeovil, Somerset BA22 7QX. Doors open from 9.30 am to 1:00 pm, and admission is £3 (BB | CR | FP | RSGB). 20 tables of traders.

01963 440 167

<http://www.yeovil-arc.com/events.php>

29 January

LINCOLN SHORTWAVE CLUB WINTER RADIO RALLY:

The Festival Hall, Caistor Road, Market Rasen, LN8 3HT. Doors open at 10 am (disabled access at 9.30 am). Indoor event. Bacon Butties and refreshments will be available on-site. Entry £2 Talk In is on 145.375MHz.

contact@m1dhv.co.uk

07777 699 069

m5zzz@outlook.com

5 February

CHELMSFORD ARS: CANVEY RALLEY Cornelius Vermuyden School, Dinant Avenue, Canvey, Essex, SS8 9QS.

<https://tinyurl.com/52emsrbc>

12 February

MID CHESHIRE ARS: RADIOACTIVE FAIR 2023, Nantwich Civic Hall. Cheshire. CW5 5DG. 100 Traders and Exhibitors Stands. Public Transport on Site (CR | BB | D | FP | RF | RSGB)

<http://radioactivefair.co.uk>

<https://midcars.org>

5 March

EXETER RADIO & ELECTRONICS RALLY:

The 2023 Exeter Radio & Electronic Rally will be held at America Hall, De la Rue Way, Pinhoe, Exeter EX4



8PW. The doors will open at 10.30 am (10.15 for disabled visitors). Admission is £3.00 (under 16's free).

(BB [book in from 10.15 am] | TS).

07714 198374

g3zvi@yahoo.co.uk

Saturday 11th March 2023

SOUTH KESTEVEN ARS JUNK SALE:

Railway Club Grantham NG31 7AU. Traders 08:00, Public 09:30 - 13:00. Traders £5, public £1. Burger van/refreshments. Contact Stewart MOSDM for more details

s.mason@skars.co.uk

12 March

HAMZILLA RADIO FEST:

Dover ARC. At the Julie Rose Stadium in Ashford, Kent TN24 9QX. Early bird tickets are available; open from 9:30 am; general

admission from 10 am. Local and national traders are welcome. Join SDR Play, Ceecom Antennas, lcom and ICQ Podcast. (BA | BB | CR | FP | D).

TBC: (RSGB | L | RF | Wi-Fi).

www.Hamzilla.uk

26 - 28 March

RADIODAYS EUROPE 2023: In the Finale of Radiodays Europe 2022, it was announced that Prague would be the host city for this now three-day event, in 2023, 26 - 28 March.

<https://www.radiodayseurope.com>

LOOKING AHEAD

- **January:** Radio & Audio Advertising Summit (London) <https://tinyurl.com/3cz6vr2s>
- **April:** NARSA 2023 (Norbreck) <https://narsa.org.uk>

• **May:** Critical Communications World 2023 (Helsinki)

<https://tinyurl.com/4tb4wsp3>

• **September:** European DX Council Conference (France)

<https://edxcnews.wordpress.com>

• **November:** Radio Tech Con 2023 (London)

<https://www.radiotechcon.com>

• **Nov-Dec:** World Radio Communication Conference (Dubai)

<https://www.itu.int/wrc-23>

WEB UPDATES

<https://tinyurl.com/yttnym3h>

<http://www.g4rga.org.uk/All.html>

<https://tinyurl.com/3ezb68d3>

<https://rsgb.org/main/news/rallies>

www.radioenthusiast.co.uk

BA Buildathon BB Bring-and-Buy CBS Car Boot Sale CR Catering / Refreshments D Disabled visitors FM Flea Market FP Free Parking LB Licensed Bar L Lectures MS Meeting Spaces RF Raffle RSGB (RSGB) Book Stall RU/PW RadioUser / PW in attendance SIG Special-Interest Groups TI Talk-In (Channel) TS Trade Stalls Wi-Fi (Free) Wi-Fi

Sign up to our FREE email newsletter at www.radioenthusiast.co.uk

Your Letters

Send your letters to: Practical Wireless Letters, Warners Group Publications plc West Street, Bourne, Lincs PE10 9PH
E-mail: practicalwireless@warnersgroup.co.uk

Morse, Revalidation and a Simple Radio

Dear Don,

Richard G3UGF (December 2022), is absolutely correct with what not to do when first learning CW. "Writing it down comes last". Shamefully, I fell headlong into that same hole too. Luckily, I didn't dig the hole too deep. So I was able to climb out easily.

Another thing not to do is to begin learning CW in increments. Like 5wpm, then 8wpm and so on, for example. Although there is a temptation to do exactly that, what you should do is to start off at 15wpm or 20wpm but leave bigger gaps between each character, then reduce the gap as you become more proficient.

Putting aside some of the problems some people might have with embracing CW, from my experience, those people that I have talked to about learning CW, told me that they were tutored to begin at a slow speed and then work their way up to a faster speed. Ridiculous. That's like saying you have to learn CW at four or five different speeds.

No wonder so many people hit a metaphorical brick wall. Oh, and forget all about the melodious claptrap comparisons with CW too. Until that is, you're able to decipher all those dots and dashes in your head without a sweat. Be it 15wpm or otherwise. Then, in an idle moment, you can sit back in a comfy shack chair and wonder if what you hear coming from your rig speaker bears a slight resemblance to a Mozart sonata, or not?

So far as revalidation is concerned, as I have an aversion to go online to do anything regarding updating most things official, when I need to update my amateur radio licence I avail myself of the Ofcom Licensing Centre telephone number: 020 7981 3131. Much simpler.

On another topic, "A Simple Radio", asks **Ian Liston-Smith G4JQT** (November 2022). Now, that would

★ Star Letter ★

The Star Letter will receive a voucher worth £20 to spend on items from our Book Store, or other services offered by Practical Wireless

Conversational Digital Modes

Dear Don,

I read with interest **G4WNC Mike's** article on conversational digital modes. I did take exception to some of his comments: in particular the paragraph: "frighteningly large proportion ... fixed digital modes".

I really like my radio station and using it; but I am an introvert. I don't want a conversation, I want a contact. This is why I like contests, minimum conversation, maximum contact. Digital modes such as FT8 bring this to a new level, zero conversation and maximum contact, with stats on the internet. It's perfect for me! There is a subset of radio amateurs who look down on the digital modes and are critical of the many of us who like these modes.

There are many facets to the hobby, my mode of choice may not be their mode of choice. I don't criticise the

rag chewers on the 80m band. I do enjoy the friendship and camaraderie that our hobby brings, but on my own terms. I am not "missing out" as Mike suggests.

Ron Piper G4LMN
St Albans, Herts

*(Editor's comment: I agree Ron, horses for courses. I too get the most enjoyment out of DXing and contesting although I did enjoy some of the excellent conversations while I was operating GB90PW. But we don't always have something in common with people we work on the air and it is pointless to try to force a conversation. For many radio amateurs, it's the technology, the propagation, etc. that are the main areas of interest. And see also **Tim Kirby GW4VXE's** comments in this issue about VHF activity.)*

truly be wonderful, wouldn't it? Like those strange people who love to get down and dirty inside a car engine bay, many of whom would yearn for a simple car like G4JQT yearns for a "simple radio". No complicated electronics and no computing devices hidden under the bonnet or a built-in spectrum analyser inside a transceiver. Just the basics.

But of course, cars like modern day commercially manufactured transceivers, are all subject

to the whims of technological advancements. Many of which (as is the case of my car and one of my transceivers, which does everything except the ironing) I never use!

And as is also the case with advancing consumer technology, manufacturers of amateur radio products in particular, but not exclusively, exploit the fact that most people cannot resist the attraction of something brand new sitting resplendent in their shacks.

Read more radio news and reviews at www.radioenthusiast.co.uk/news

The bad news: unless we vote with our wallets and refuse to buy radios where functionality, gizmos and so-called user-friendliness is mainly redundant, the idea that a truly "simple radio" will magically make an appearance, is delusional.

The good news: purchase a transceiver that was manufactured 20 or 30 years ago.

Or maybe build a simple radio? Or just go with the flow.

Ray Howes G4OWY/G6AUW
Weymouth, Dorset

(Editor's comment: Which reminds me, Ray, of a conversation many years ago with the editor of Japan's CQ Ham Radio magazine, at the time that amateur radio transceivers were starting to include general coverage capability, rather than just the amateur bands. He told me that this was because the Japanese market loves features – the more the merrier. Yes, performance might suffer but as the majority of Japanese amateurs lived in small apartments with limited antennas, this was probably not a criterion. Sales of transceivers without general coverage plummeted. And the rest of the world had to put up with what the home market wanted – still the case, I suspect.)

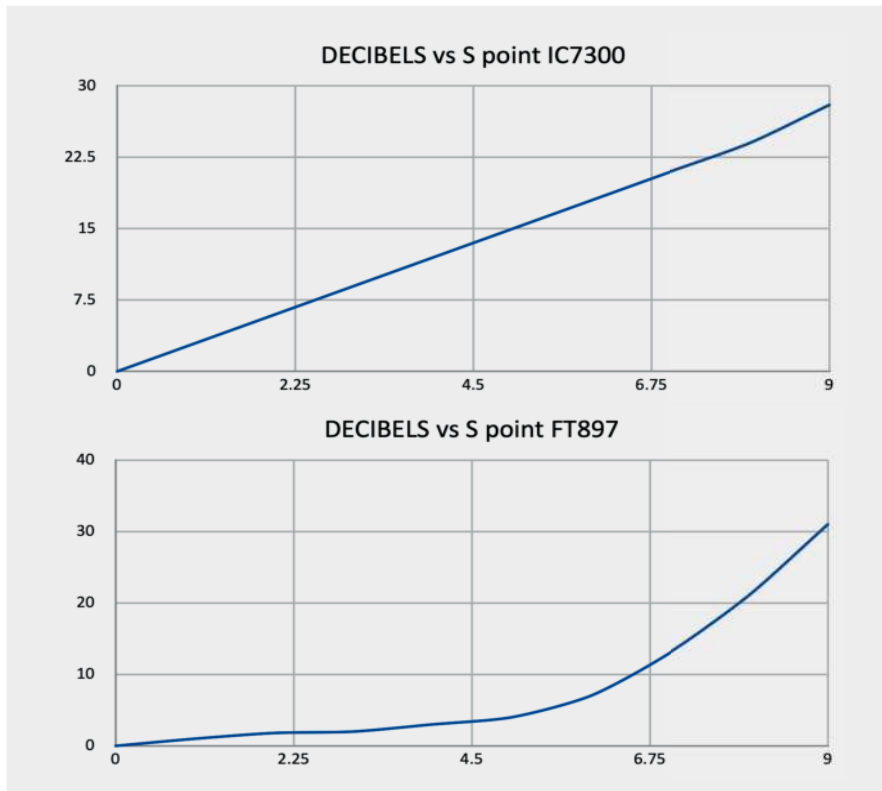

S Meter Calibration

Dear Don,

I had occasion to measure the S-meter versus decibel level of my Icom IC-7300 and Yaesu FT-897 for a carrier on SSB. See the two graphs.

I was shocked to find, at least for my particular FT-897, S1 to S4 only require ~2dB increase and S1 – S6 only 7dB. The IC-7300 on the other hand is linear at ~3dB per S-point.

Ian J Dilworth G3WRT

Next Month

in the UK's best & only independent amateur radio magazine...



PRACTICAL WIRELESS www.radioenthusiast.co.uk

OCTOBER 2022 THE UK'S NUMBER ONE AMATEUR RADIO MAGAZINE SINCE 1932

HOME BUILD Make an analogue display digital VFO, and a jig for soldering wires

TESTING YAESU'S FTM-200DR/DE
A mid-range model with high-end features

Contest Lowdown
The results of PW's 2022 144MHz QRP Competition

HISTORY Amateur Radio and the Public Sector
The birth & present day role of public sector radio communications services

ARCHIVE Project from...
Building an... receiver

NEW PRODUCTS
Latest gear and news across the hobby

FEBRUARY 2023 ISSUE
ON SALE 12TH JANUARY 2023
AT ALL GOOD NEWSAGENTS

The publishers reserve the right to change content according to circumstances.

BUILD YOUR OWN SHACK: Stuart Vanstone M0SGV offers a blow by blow account of how he built a new outdoor shack from scratch.

REVIEW OF JPC-12 VERTICAL ANTENNA: Richard Constantine G3UGF takes an in-depth look at this range of new portable antennas from China.

VALVE & VINTAGE: Dr Bruce Taylor HB9ANY describes a ground-breaking shortwave transistor receiver, the Heathkit Mohican.

CAN YOU HEAR A WSPR: Billy McFarland GM6DX describes how he set up a WSPR beacon on the Isle of Man.

THE INVERTED LAZY L MULTIBAND EFQW: Roger Wheeler G3MGW builds a multi-band antenna for limited space.

There are all your other regular columns too, including HF Highlights, World of VHF, The Morse Mode, On a Budget, What Next and Data Modes as well as your Letters, Latest News and more.

Yaesu Spotlight

Yaesu FTdx10 & Its Sibling FT-710

Yaesu Musen. Bringing more Amateur Radio products for the Ham Radio Operator than any other manufacturer

FT-710 AESS

HF/6/4m All Mode Compact Transceiver

Replacing the best selling FTdx1200, this new model employs SDR technology and a whole host of advanced features expected from a transceiver in 2022.

For latest price information and availability see: www.HamRadio.co.uk/FT710

YAESU

ML&S

a Perfect Partnership

We may all sell the same products but the service from ML&S is in a different league.



FTdx10

If you want a more enhanced performance version of the FT-710 including a larger display then consider the FTdx10.

For latest price information and availability see: www.HamRadio.co.uk/FTdx10

The SP-30 shown above is a cost option for the FTdx10

MARTIN LYNCH & SONS LTD. THE WORLD FAMOUS HAM RADIO STORE

ML&S

www.HamRadio.co.uk

SAFE ONLINE SHOPPING. E&OE



0345 2300 599

Wessex House, Drake Avenue, Staines, Middlesex TW18 2AP

E-mail: sales@hamradio.co.uk

Opening Hours: Mon - Fri: 8.30am to 5pm. Sat: 9am to 4.30pm.

International Tel: +44 1932 567 333

Carries the Yaesu genes for true RF performance

- SDR circuit emphasizes Receiving Performance
- Powerful RF Front-End & Low Noise Oscillator Enable Phenomenal Multi-Signal Receiving Characteristics*
 - RMDR : 113dB+ • BDR : 127dB+
 - 3rd IMDR : 102dB+ • TX Phase Noise : -143dBc/Hz
- Band-Pass-Filters dedicated for the amateur bands to eliminate out-of-band unwanted signals
- Built-in High-speed Automatic antenna tuner
- Effective QRM rejection by Dual-core DSP
- AESS (Acoustic Enhanced Speaker System) with included SP-40 speaker to create High-fidelity audio output
- 3DSS, real-time 3-Dimensional Spectrum Stream presentation
- High Resolution 4.3-inch TFT Colour Touch Panel Display
- VMI (VFO Mode Indicator) shows the current operating mode
- "PRESET" Mode functions most suitable for FT8 operation
- Equipped with the External Display terminal

*Multi-signal receiving characteristic: 14MHz band/2kHz separation

*TX Phase Noise: 100W, CW mode

- Display is not included. The image is shown with an optional third-party external display that may be connected using a DVI-D digital cable.
- FT-710AESS includes External Speaker SP-40.



HF/50MHz 100W
COMPACT SDR TRANSCEIVER w/ SP-40
FT-710 Aess
Acoustic Enhanced Speaker System