

Hot Iron

Issue 14

"Journal of the Constructors Club"

Winter 1996



Editorial

I am a little later than usual compiling this issue of Hot Iron (Dec. 7th), so it is quite timely to wish you all a very Happy Christmas and prosperous New Year! May you also enjoy good health and an excellent year in your radio activities. Looking back over this year, it has been about the busiest that I can remember, both around the farm and in the 'Laboratory'. One of the pleasures of living in an old farmhouse, apart from not having to worry too much about damage to MOS devices from static electricity, is that I can sit in front of a log fire typing away in the half of the room that is my farm office. (Incidentally, the wood is fallen willow trees which have to be cleared up and so benefits everybody!) It feels very 'Christmassy' and, given the freezing fog outside, there is little to draw me away! The other half of the room is 'The Laboratory'; this is instantly recognisable as a typical radio amateurs shack piled high in literature, components, wire and home-made bits and pieces. Under considerable pressure from Madam, who also has a desk somewhere in here I

understand, I rearranged the computer table so that it now faces the Laboratory - in consequence I find it much harder to concentrate on the text when some half finished project is in view on the bench opposite! Soon, I expect there will be pressures from my daughters to erect some Christmas decorations, the snag is what to attach them to! Everything is always in constant use and/or fragile! (It sounds like a scene for our cartoonist member GW3COI.) I am sure that you all have impeccable shacks - at least modern equipment is much more spouse friendly than the 19" racks of yesteryear! Whatever your domestic arrangements, have a very good year in 1997.

Tim Walford G3PCJ Editor

Kit developments

The *Frome* CW TCVR is now available. It is a 5 Watt any single, or any pair of bands, by plug-in cards for 15 to 160m. It has a DC receiver with switch selectable sharp phone or CW filters. Double tuned RF filters and a varactor tuned VFO with crystal mixing scheme to give stability and avoid chirp. The Manual (£5) is available separately if you wish to assess the project first. Single band TCVR £85, or any two band TCVR £115 + £1 P&P. There is also the possibility of double sideband suppressed carrier phone operation.

By the time you read this, the January 1997 Practical Wireless will be out, with an article by Rob Manion G3XFD about the *PW CADET*. This is a collaborative project between us for a beginners project which should be quite within the abilities of 10 year olds upwards. It is an AM broadcast station receiver for the medium wave band, and short wave from about 3 to 6.5 MHz. It has three stages using only FETs for simplicity, ease of understanding and building. You only need a 9 volt PP3, walkman type phones, solder, soldering iron and cutters. £24 + 1 P&P from PW or WE. The *CADET PLUS* will add a BFO and RF amp.

The re-designed *Signal Generator* should be available soon; if you are interested and you haven't heard from me recently - give me a call. The revised 12 volt 10/15m to 160m 25 Watt *Booster* is also imminent!

Hot Iron is a quarterly newsletter for radio amateurs interested in building equipment. It is published by Tim Walford G3PCJ for members of the **Construction Club**. Articles on simple theory, construction, testing, updates on kits, questions and suggested topics are always wanted. Please send correspondence and membership inquiries to Upton Bridge Farm, Long Sutton, Langport, Somerset, TA10 9NJ. Tel & Fax 01458 241224 The Copyright of all material published in Hot Iron is retained by TRN Walford. ©. Subscriptions are £6 per year for the UK (£8 overseas) from Sept 1st in each year. June 1st 1996.



Wide Range Grid Dip Oscillator by G3DII

Joseph Bell, who is a frequent correspondent about FET amplifiers and has an IRF510 operating on 10m, has sent along some notes about his search for a gadget that would allow him to measure the resonant frequency of parallel tuned circuits down into the kiloHertz region. "I tried driving digital dividers from an ordinary HF GDO but without much success. Following on-air discussions with GD3FXN, I was introduced to the circuit shown alongside. It is based on our old friend the multivibrator; I had to use extra decoupling for the low frequencies and increased feedback. Now you can place a parallel tuned circuit between the 'test' points and it will oscillate from low LF up to VHF! For instance, I stuck 2200 nF across a pot core and the counter indicated 2 KHz. If you have a counter, it is easy to calculate the inductance of any coil with the aid of a tolerably close tolerance capacitor (silver mica for instance). The formula for L or C unknowns, is that the LC product (L in microHenries, C in picoFards) is equal to 25330 divided by the square of the resonant frequency in MHz, so work out the LC product and then divide it by the value of the known L or C. I used a variable feedback capacity so that its value could be kept to the minimum for a reasonable waveform. A 9 volt supply is sufficient."

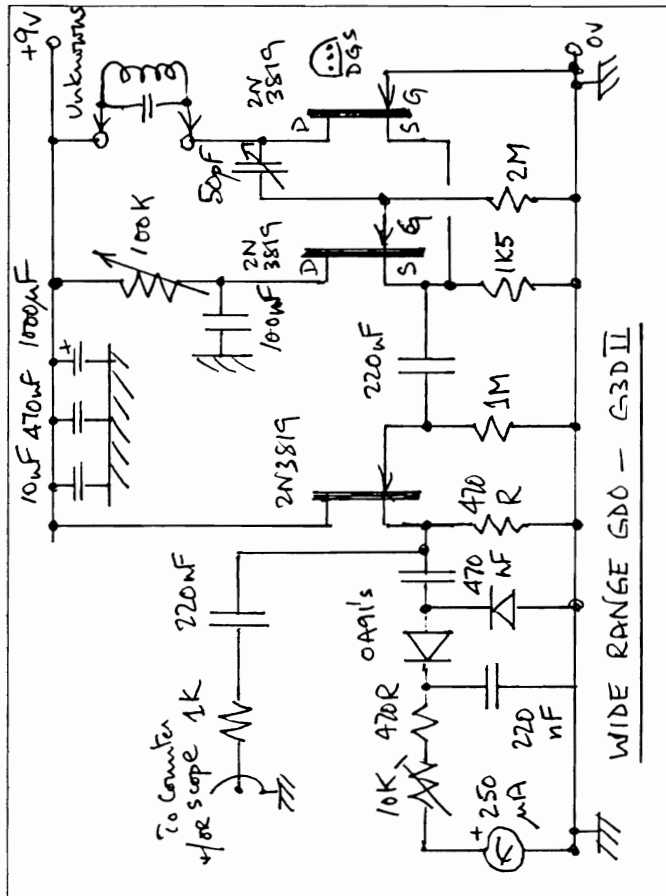

CW audio filter

Direct conversion receivers need to have narrow audio bandwidths since it is the audio filter characteristics which determine the selectivity of the receiver. Quite often the audio filter is sufficiently wide (about 2.5 KHz) to pass phone signals without degrading voice quality but this means that several different CW stations can be copied at the same time! Hence the need for a much narrower audio filter for CW. Ideally this would be a bandpass filter so as to reject signals both above and below the desired beat tone. Since most people use a beat tone near 800 Hz there is more scope for unwanted signals coming through within the 800 to 2500 Hz range, hence the common simple solution to use a low pass filter which is 3 dB down at about 800 Hz with increasing attenuation above 800 Hz. This still allows lower tones through between the RX's low frequency pass band (typically 300 Hz) and 800 Hz. Hence the ideal is a bandpass filter centred on 800 Hz. They are not

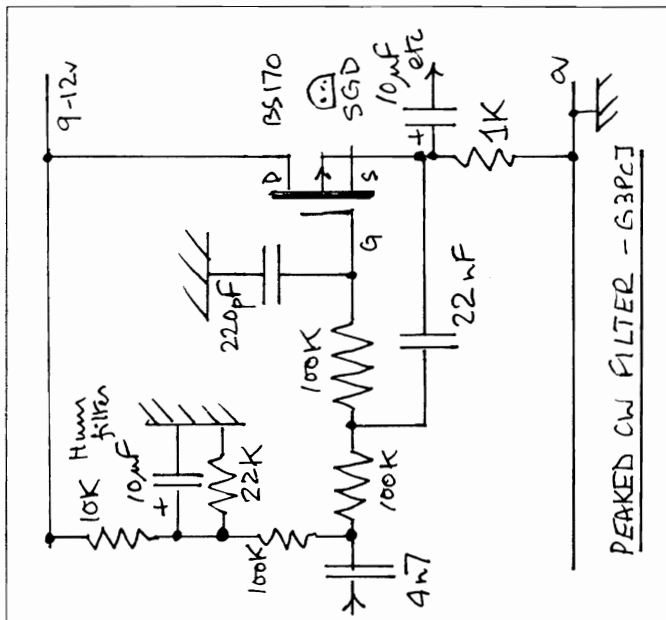

often provided because they are complex if the filter slope is to be reasonable. The circuit above is a reasonable compromise though and can make a great improvement if the audio passband is wide. It is basically a humped low pass filter with much better attenuation on the HF side where it is most needed. The 22 nF feedback capacitor is larger than normal giving a slight (but controlled) tendency towards oscillation - it does not actually oscillate but the filter sharpness is much increased. The circuit consumes only a few milliAmps and can be fed from a hum free 9 or 12 volt supply. In the *Martock* receiver, the filter output feeds the 4K7 AF gain control so using a 68 nF output coupling capacitor gives attenuation to signals below 500 Hz; hence the overall effect is a bandpass filter with sharper attenuation on the all important HF side. G3PCJ

Soldering Extractor Fan by Dick Turpin G0BFU

A recent visit to my surgery, where there was a notice saying "Fresh air is not free", made me think others might be interested in my fume extractor. I have long been aware of the dangers of breathing soldering fumes, particularly from the 'enamel' on modern copper inductor wire. Many amateurs do their construction in small rooms, or in wooden sheds, and in cold weather with closed doors and windows. Good ventilation, without getting cold, is however essential. I use a small 5 volt fan (sold cheaply at rallies) which is permanently connected to the incoming mains supply of my soldering station. The fan needs DC so a small bridge rectifier fed from the 6 volt heater winding of an old receiver mains transformer is all that is needed to keep it going whenever the soldering station is turned on. The fan exhausts through a metal tunnel out through the shack wall. An empty cat food tin, less top and bottom makes a tube to bring the fan intake nearer the source of fumes. A grill is desirable on the outside of the wall to prevent draughts when not in use; if the 'wall' is wooden as in a shed, then drilling multiple holes is an alternative. The holes or grill should be covered with a metal shade or cover to shed water and add to draught prevention. Sealing of the various joints can be done with bluetack, mastic or putty. If necessary, a longer tube can be made with wood or 3 inch sewer PVC ventilation pipe. In Summer, it can also boost air flow through a hot shack!

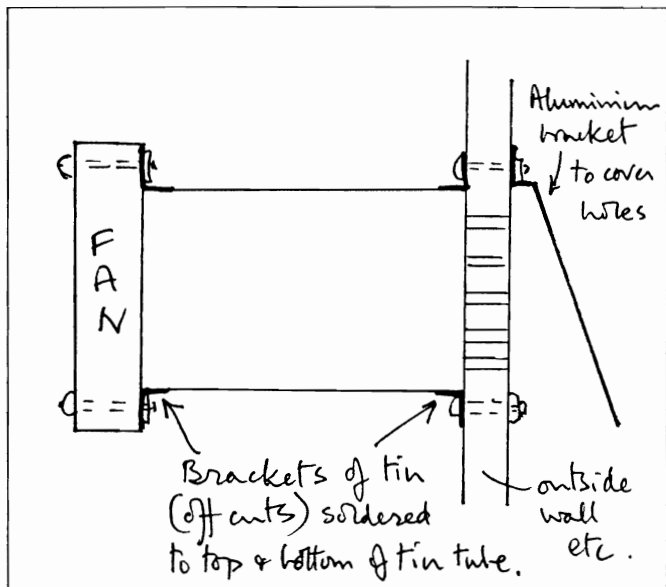

A grill is desirable on the outside of the wall to prevent draughts when not in use; if the 'wall' is wooden as in a shed, then drilling multiple holes is an alternative. The holes or grill should be covered with a metal shade or cover to shed water and add to draught prevention. Sealing of the various joints can be done with bluetack, mastic or putty. If necessary, a longer tube can be made with wood or 3 inch sewer PVC ventilation pipe. In Summer, it can also boost air flow through a hot shack!

Switched Antenna Attenuator by Derek Alexander G4GVM

Anyone operating a Direct Conversion receiver in the evening will know that an RF/Aerial attenuator is a must. I had no room on the front panel of my transceiver for the usual potentiometer control so an alternative had to be found. The three position miniature ON - OFF - ON toggle switches came to mind. This switch and associated resistors take up very little room and fit easily onto an already crowded front panel. The resistor values shown give two steps of attenuation satisfactory to my needs but would form a good starting point from which to experiment if different levels of a signal reduction are required. The fact that impedances in and out are no longer a nominal 50 Ohms is less of a problem than the breakthrough without the attenuator!

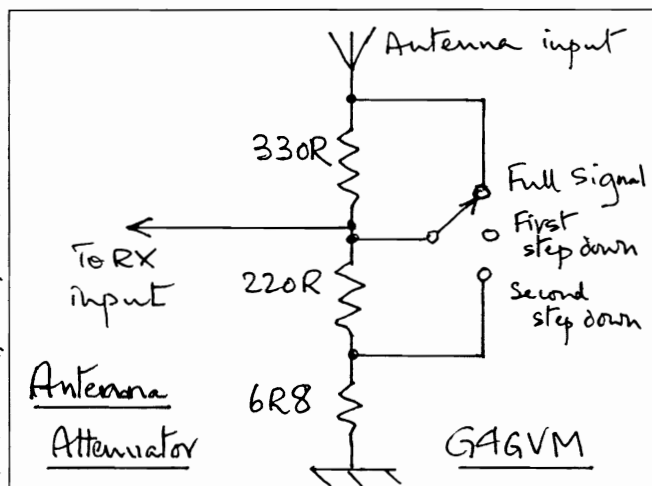

Soldering coaxial leads

Peter Barville, G3XJS, has sent me some notes gleaned from the Internet about soldering jumpers on PCBs where the cable has to be bent sharply adjacent to the PCB for it to look smart. However the methods suggested have more general applicability. The key is to prepare the braid before making any connection to the coaxial cable inner conductor. After stripping back the outside cover perhaps 3/4 of an inch, the braid can be carefully unwoven with the aid of a small spike. The mass of single strands of the screen can then be twisted into a single 'core' on one side of the coax. Cut off the surplus leaving a tail of about 3/8th of an inch long into which a stiff wire can be inserted. The offcuts of some component having fairly thick leads is best. This single wire is then soldered into the middle of the bundle being quick with the soldering iron in order to avoid heating the insulation between inner and the braid. Make certain there is no mechanical strain on the coaxial cable or inner when doing this. Before making the screen connection to the PCB, prepare the inner conductor by stripping the insulation and tinning. The screen connection is made to the PCB by inserting the single ex-component lead into the PCB screen hole and soldering. Finally make the inner connection. (An alternative approach with small flexible cables, is to pull the inner out through a hole in the screen without unravelling it.)

PCB Artwork

Craig Douglas, G0HDJ, writes that he experiences frequent problems with hairline fractures in his own self laid out PCBs. I can assure Craig that he is not the only one! In the case where the tracks are being laid on transparent film, such that multiple copies can be made by exposure with ultra-violet light onto photo-resist coated PCBs, the answer is to examine the artwork very closely with a magnifying glass after it is complete. This is often helped by doing it over a light box with an ordinary white light source. You may even be able to fit an extra ordinary bulb inside the same light box that is used for ultra-violet exposure. For single projects where the artwork forms the etching resist, it is much harder to see the breaks as they are against the darkish background of the copper. My only suggestion is to do the whole layout twice over because the chance of two breaks occurring right on top of one another is extremely remote. This may seem like a waste of effort but it is often trivial compared to the time spent hunting for faults, or supposed design errors, only to find a broken lead! Many home 'etchers' will be aware that the gap on the copper arising from a hairline crack is much wider than the break in the artwork because the ferric chloride tends to etch away the copper just under the edge of the resist material. Craig asks about shelf life and materials. In my experience, the special rub-on transfers intended for PCB work do have a finite shelf life, after which they are prone to cracking or failing to peel cleanly from the backing paper after being rubbed down. I suspect this is measured in terms of a small number of months. For ultra-violet work, a very dense black material is necessary to stop penetration of the light rays. The special rub-on transfers are made of suitably dark material but often it is difficult to obtain all the line widths and shapes, or letter sizes that you require. 'Lettraset' type transfers can be used with care, I use a range made by a firm called Graffik. I have not used them as an etch resist though. I have also tried copying a pattern with a photo copier but it is a complete waste of time! The deepest shade of black that any of my local machines will print is still slightly transparent! At one stage I required an image inversion for a track patterned ground plane and the only satisfactory method that I found was to have it done photographically; this was terribly expensive and inflexible since every hole change required the ground plane artwork to be re-photographed! That is why my circuit board ground planes do not have any etching on them at all. I have not had much joy finding pens with very fine points with a very black ink either; if they are really black, they seldom dry on transparent film which is non absorbent. Occasionally I have to touch up the resist on a UV exposed board, I use a Dalo pen which produces a blue thickish varnish - it works very well provided you let it dry before putting the PCB in the ferric chloride. I am told that nail varnish and various brands of hair spray are also very effective but I am not quite sure how one gets a track pattern with a spray on lacquer. I have also considered exposing the output from my HP deskjet printer with ultra-violet light; even after two passes through the printer (which did align very well) on ordinary paper, the image was still not dense enough for the ultra-violet. Do any members have experience of using CAD programs with low cost printing techniques to make PCB artwork? G3PCJ

Taunton matters

Gerrit ten Veen PA3FOY has sent me some photos of his splendid Taunton; unfortunately the photocopier does not do justice to his handiwork (like the PCB artwork!) but I was able to note the use of Meccano (I still have the remnants of my childhood sets!) and also a piece of folded aluminium as a temporary front panel with the PCB sitting on a small cardboard box prior to ultimate boxing. This had kept lead lengths reasonable and still allowed access to the underside. Poor Gerrit suffered a heart attack and now has more time for radio as he is off work - we all wish you well for 1997 and beyond. He mentions unwanted markers at 500 KHz intervals, these are free calibration markers which are a by-product of filtering compromises! They arise from the VFO having a 500 KHz swing with crystals which are a whole number of MHz. Ray Donno also reports that he has had his Taunton going on 10m producing 0.5 Watts without the extra transmit amplifier mentioned by Tony Measures. He used TOKO 4612s instead of 4613 without ill effects. He wonders if 10 and 12m would work on the same two band card; I have my doubts owing to the extra lead lengths and resulting capacitance. G3PCJ



Measuring Components

David Proctor, G0UTF, suggests we should all have instruments to measure parts bought at rallies etc. and points out that for most purposes a 10% tolerance is quite close enough. He suggests the scheme indicated right for measuring capacitance, or alternatively, a bridge circuit comparing unknowns against standard components. I suppose that I am spoilt in that I have to buy new parts from repeatable sources for kits and I therefore use these for development work. However many years ago I made up an instrument which was a combined AC voltmeter and RLC meter. The basis is a sensitive AC voltmeter able to read from 5 mVolts to 50 volts RMS FSD. Components are measured by using them to determine the gain of an op-amp, to which is applied a known constant 50 mVolts and then measuring the output voltage. The voltmeter part of the circuit actually responds to the average value of the waveform but for sinusoidal signals this is of no consequence provided it is calibrated with a sine wave signal. The voltage, or component value, is read off the meter scale directly (when set to a suitable range). The V and C scales work forward but the R and L scales read backwards which is not quite so easy but as they are used less often it hardly matters. The use of the following frequencies allows the component values to be read off the same scale as is used for voltage/resistance. Capacitance is measured with a frequency of 3.18 KHz while inductance is measured with a frequency of 15.9 KHz. The following table gives the impedances and FSDs. R_f is the switch selected feedback resistor.

| R_f | $V_{in\ FSD}$ | R or X_{IN} | C_{FSD} | 3.18K | L_{FSD} | 15.9K |
|-------|---------------|---------------|-----------|--------|-----------|-------|
| 1M | 5 mV | 1M | 50 pF | 10 H | | |
| 100K | 50 mV | 100K | 500 pF | 1 H | | |
| 10K | 500 mV | 10K | 5 nF | 100 mH | | |
| 1K | 5 volts | 1K | 50 nF | 10 mH | | |
| 100R | 50 volts | 100R | 500 nF | 1 mH | | |

The table is based on a R_{in} for voltage of 100K and a reference voltage of 50 mVolts. I used a 1 pole 12 way switch which made it possible to use the intermediate values with a FSD based on 15 for voltage. The meter part of the circuit is shown in the middle right. The meter movement is within a full wave bridge rectifier inside the op-amps feedback path so that the diodes effectively become perfect! I used 741 op-amps but more modern types such as the TL071 or dual 072s could be used. 9 volt supplies (of both polarities) are the minimum but up to + or - 15 volts is alright. The circuit that I used to provide the 50 mVolt reference is shown in the lower box. I used OA10 diodes but probably 1N4148s will be OK. Please write if this is not clear enough for building yourself. G3PCJ

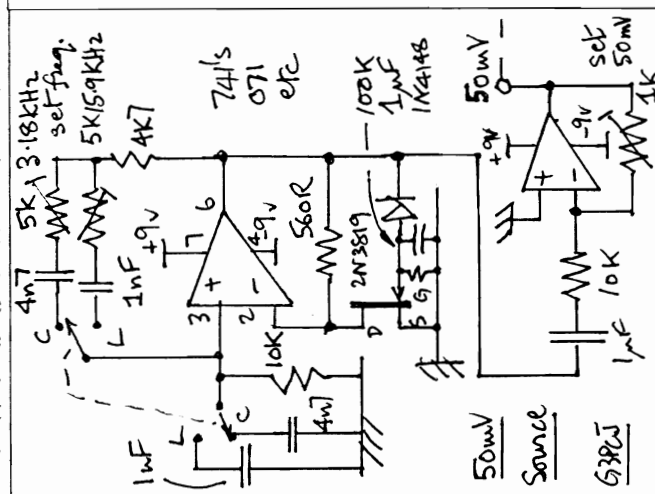
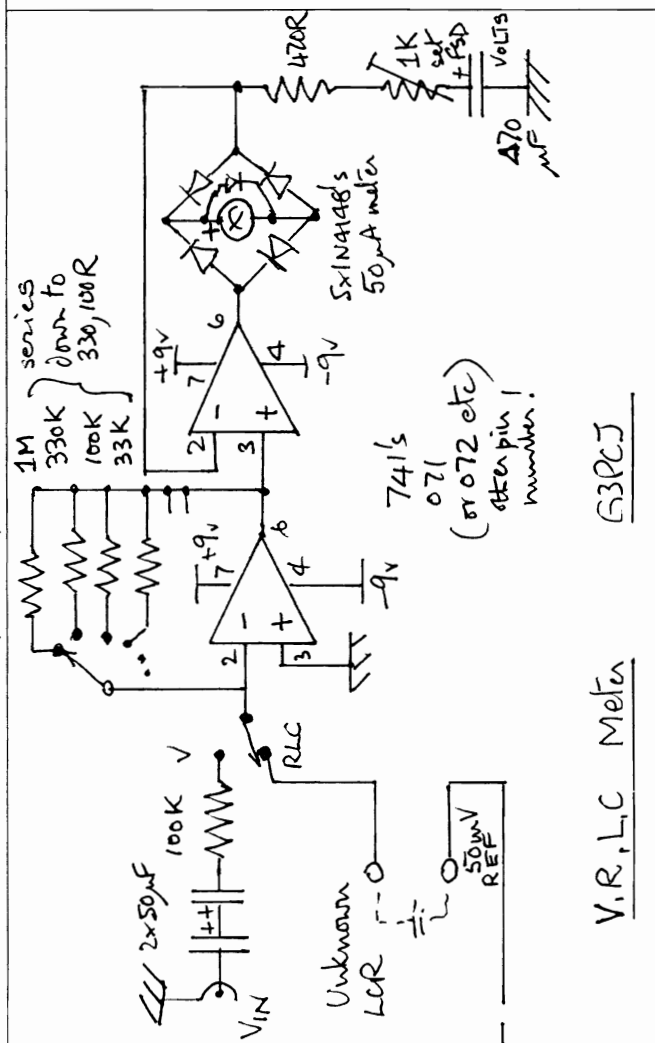
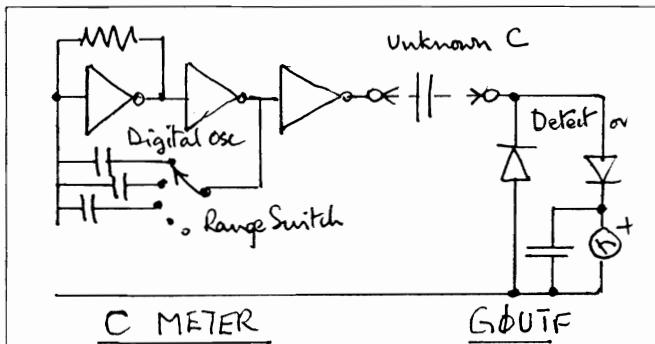

Antenna Matching Units and other matters

Stephen Melling writes that he still has difficulties with power measurement and the words in our licences. He points out that power is normally measured in terms of the RMS heating effect whereas the licence talks about the mean power and there is a small but significant difference. I passed this onto my technical consultant Eric G3GC but he apologises as he has been heavily occupied producing the newsletter for the Yeovil ARC; he intends to cover this as part of an article that I have asked him to write on decibels. Like several others, Stephen suggested 50/70 MHz rig kits and an antenna matching unit. These have been on my mind for a while, but neither is easy. The rig would be a single band phone superhet (with the standard optional CW kit) but doing the TR switching around the IF strip is not possible with 4066 switches so an alternative way has to be found to keep the price reasonable. The 'VFO' will have to be an overtone crystal mixed with a low frequency actual VFO for stability. I hope to use NE612 mixers with a dual gate MOSFET IF amp as standard. For the RF output, it will not be possible to use the IRF510 on 50 or 70 MHz so, on cost grounds, I think the output stage is likely to be a 2N3866 producing about 1 Watt. I have an open mind as to whether it should have extras like AGC, S meter etc.. Any thoughts would be most welcome.

The circuits for AMUs are easy but I have failed so far to come up with what I regard as a cost effective kit owing to the difficulties with inductors and variable capacitors suited to up to 25 Watts. I have not yet seen small roller inductors, so it has to be equal spacing tapped inductors with a rotary switch perhaps in a coarse and fine arrangement; the alternative is multiple inductors increasing in binary steps and a switch for each. Neither is elegant! I had hoped to use small binary coded rotary switches but the switch elements are commoned which is a snag. Air variables are terribly expensive, particularly for large values with adequate plate spacing for about 500 volts which might be generated into a high impedance feeder. I plan to incorporate a resistive matching bridge which will also indicate output power. This is the easy part. The intended circuit is shown right but for the present you will have to go part hunting at rallies (with the component checker)! Another interesting point concerns the mechanical style; I envisage a Pitney style unit but it hardly needs an etched PCB as most of the parts are likely to be mounted on the back of the switches etc.. I hesitate to put any particular style of input/output connectors on it because so many different types are in use - screw terminal PCB blocks again I think! G3PCJ

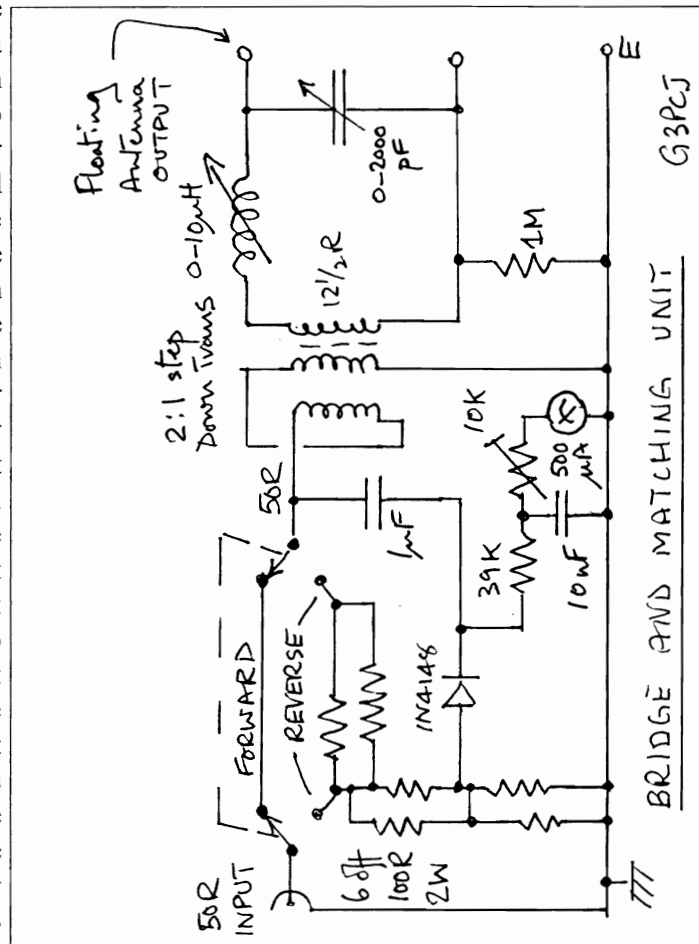

New projects!

In the light of a customer's request, I spent much of last Sunday doodling new designs. Several interesting ideas are beginning to germinate! A 5 Watt 80m CW TCVR using just a couple of chips and a few FETs with a ceramic resonator which seems to give 60 KHz coverage in the top half of the CW section. The next item was a simple regenerative TRF RX for 20, 40 and 80m having tuning limited to just wider than the bands. The last item is a 5 Watt CW crystal mixing transmitter for any single band 20 (maybe 15m) to 160m to go with the Martock. This would use much of the Frome's circuitry. I will let you know how these develop.

The Somerset Contest

Don't forget to have your rigs ready for this contest organised by the G-QRP Club over any four hours of March 27th 1997 on the 80m band only. Full details in the Autumn 1996 SPRAT Iss number 88. First prize is a *Frome* receiver for the band of your choice; all properly completed entries also go into a draw for a *Pitney*.

Happy Christmas to you all from Tim G3PCJ