

# Hot Iron

Issue 17

“Journal of the Constructors Club”

Autumn 1997



## Editorial

Welcome to the start of a new year of construction activity and a sincere thank you to all subscribers; it is very pleasing to see that quite a large proportion of you have been members since we started back in 1993. I well remember one particular founder member (and subsequent contributor) who expressed some reservations about the ability to keep material flowing, recounting his experience in another field, that the main difficulties came in year two or three when all the easy topics had been written about! It is a relief to be passed that stage and my file of material awaiting publication goes up and down like most people's keys - far too quickly for my liking! I am always pleased to have contributions and suggested topics, so thank you to those who responded when renewing their subscriptions.

It is sad to see the passing of a national journal but the announcement in the September Radcom that DIY Radio would not be published any more is hardly surprising with a readership of under

2000. The effort involved in putting together a high class colour magazine is daunting - particularly if advertisers are reluctant to take space. One of my best customers remarked the other day on the phone that amateurs are a tight fisted lot! It continues to surprise me how some worry about the cost of individual parts and then loose all the price advantage on postage charges. With DIY Radio aimed primarily at young people, and many articles explaining how to do things for one's spare change, there was not much hope of advertisements paying their way. I advertise regularly in Radcom because over the years I have found that RSGB members have the highest conversion rate from inquiries into kit orders - but it is not easy to deduce whether inquiries arise from adverts or from news items following press releases. Advertising is one of those irritating overheads - it has to be done because if you don't tell people about your products they can't know of its existence and don't order!

## Kit developments

I am pleased to report that my prototype Street TCVR has now been working on 80m for some weeks. I equipped it for 80 and 6 metres because the former allows easy testing etc. of the basic rig and 6m should show up the problems of the higher frequency bands - and it has! It is not yet ready for release owing to a couple of problems which took time to cure during my harvesting activities. The TX strip had insufficient gain at 50 MHz requiring an extra IC with partial relayout of the transmitter PCB. Thank you to those who are waiting having expressed an interest, particularly for 6m. About half of the manual is written. Obtaining an electrically robust 50 MHz design is proving quite challenging!

In the bath, I ponder the merits of a band changing phasing CW receiver! The scheme would use crystallised converters in front of a narrow band VFO phasing RX. Any interest? Tim G3PCJ

*Hot Iron* is a quarterly newsletter for radio amateurs interested in building equipment. It is published by Tim Walford G3PCJ for members of the **Construction Club**. Articles on simple theory, construction, testing, updates on kits, questions and suggested topics are always wanted. Please send correspondence and membership inquiries to Upton Bridge Farm, Long Sutton, Langport, Somerset, TA10 9NJ. Tel 01458 241224 The Copyright of all material published in *Hot Iron* is retained by TRN Walford. ©. Subscriptions are £6 per year for the UK (£8 overseas) from Sept 1st in each year. June 1st 1996.



## Oscilloscope timebases & triggering

(This note was to have been written by Dick G0BFU but sadly he is not yet fully recovered from his stroke.)

The first article in this series explained how you could measure the peak to peak amplitude of an applied signal; the purpose of the timebase is to display the shape of the waveform as well as its amplitude. In a conventional scope, the waveform is drawn out in 'real time' as the signal is applied just as you would draw a graph on paper of some signal. (A sampling scope does not work in real time because it 'samples' the signal repetitively and builds up the picture over many cycles of the applied signal - this allows a higher effective bandwidth.) In the conventional scope, the spot is moved sideways along the X axis of the tube at a constant rate irrespective of what is going on in the vertical or Y direction - hence each centimetre of the X axis represents a given time. At the end of each sweep, usually to the right, the spot is returned quickly to the left of the screen to repeat the linear sweep to the right. The spot is usually blanked off during this flyback period. The speed of the linear progression to the right is known as the timebase speed or sweep rate and is measured in time per distance - a modern scope will have a large rotary switch enabling sweep speeds from about 1 second/centimetre to around 200 nS/cm. The voltage which generates this spot motion has a sawtooth shape and it is important (for the making of accurate measurements) that it be linear and well calibrated. In the example shown below, an HF sine wave is being displayed with a sweep speed of 500 nS/cm or 0.5  $\mu$ S/cm. By measuring the distance (using the scope's graticule) between successive crossings of the same chosen instantaneous voltage level (often 0 volts for convenience), the time interval between those points (period) can be measured and hence the frequency worked out. (Frequency is 1 divided by the period of the waveform.) In the example, the period is 4 cm on the tube or  $4 \times 0.5 = 2 \mu$ S giving a frequency of 1 divided by 2 $\mu$ S which 500 KHz. This drawing out process allows you to see the shape of the waveform from which you can deduce if it is a single sinusoidal signal or whether it is 'distorted' by the presence of harmonics of itself. Digital signals can be displayed showing the sharp transition from one digital level to the other and vice-versa. With such signals, often the rise (or fall) time between the two digital levels is what is of interest.

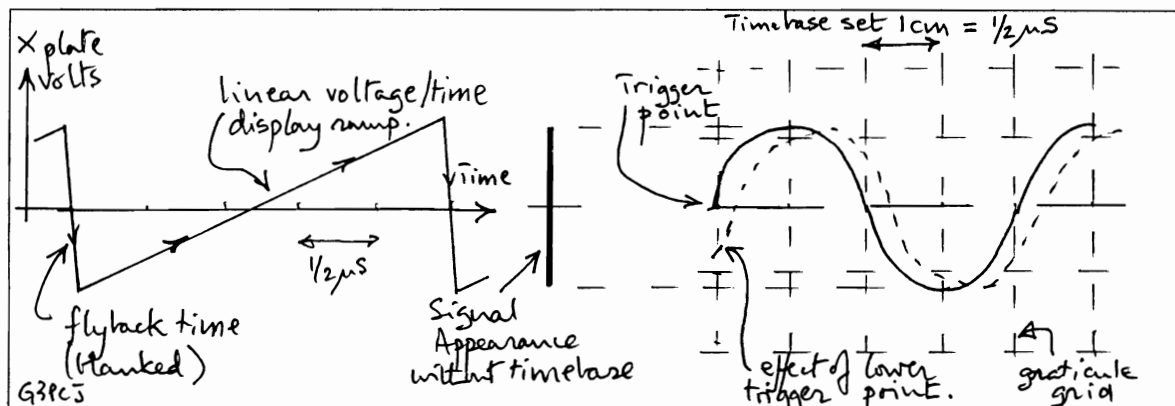

To produce repeated sweeps across the tube face in exactly the same position, which is necessary to avoid a totally confused picture when sweeping faster than about 0.5 S/cm, the sweep voltage must start its excursion across the face at the same instantaneous voltage of the applied signal. The sweep thus needs to be 'locked' or triggered by the applied signal on the Y plates. (Old scopes did not always have this facility, or even if provided, it was very poor on the high speed ranges making waveform observation very difficult.) The modern scope usually has controls to select the *coupling*, *slope* and *level* of the trigger point. AC coupling allows shifts in the DC level of the applied signal to be ignored whereas with DC coupling, triggering will always be at the same actual voltage level. The choice of *slope* allows triggering on the rising or falling slopes of the applied signal and *level* adjusts the trigger point on the applied signal. Sometimes there will also be a *hold-off* control which prevents re-triggering occurring too quickly after the end of the sweep - this is useful where many cycles of a signal are displayed during one sweep. As described above, if there is no input signal on the Y plates with nothing to trigger the sweep or if the trigger controls are poorly adjusted, then the timebase is inactive with no spot excursion along the X axis and probably a blank screen! Hence the modern scope has an *auto sweep* facility allowing the timebase to run freely in the absence of a suitable Y triggering signal - this at least gives a horizontal line all the time which will be at 0 volts in the absence of a Y input signal. If there is a signal, and the triggering controls are properly adjusted, then triggering occurs correctly, otherwise with signals below a few Hz auto-sweeping will occur. Usually when making very slow speed observations it is best to turn off the auto facility. More expensive scopes may also have facilities for delayed triggering which will allow closer examination of part of a waveform or events some adjustable (delay) time after the trigger point - this is very useful in complex logic circuits.

For general analogue use, the normal sweep speed control is adjusted to show about 2 to 5 cycles of the applied waveform. If most of the waveform is clear but other parts are fuzzy, it implies the presence of more than one signal, this maybe unwanted harmonics which will often appear as fuzz at the top and bottom of the wanted signal. With careful adjustment of the trigger point to be in these fuzzy regions, you maybe able to display the harmonic content; however if the unwanted signal is not harmonically related (e.g. additional 50 Hz hum) then the fuzz can not be properly resolved.

The bandwidth of the Y channels will limit the ability of the scope to display signals irrespective of timebase speed. A typical modern scope might have a Y channel bandwidth of 20 MHz suggesting that actual displayed spot excursions will be 3 dB less or reduced to 70.7% of what they should be at 20 MHz and will be even less as frequency is increased. The bandwidth figures are often worst case and the scope will often actually perform correctly to a higher frequency - even so, the scope can still be used above this region by making relative (instead of absolute) measurements as some component etc. is altered. However, at these high frequencies the scope's ability to trigger properly will be severely tested making observations increasingly difficult. The same Y channel bandwidth limitation will also limit the smallest signal rise or fall time that can be displayed - in consequence if a 5 MHz digital signal from a generator with very short (say 1 nS) actual rise and fall time edges were displayed, then the apparent rise and fall time would be those of the scope Y channel (around 10 nS for a 20 MHz scope) instead of the 1 nS of the signal generator.

If the scope has two input Y channels, then usually the timebase can be triggered from either Y input (or from an external signal). This is valuable for looking at the inputs and output of some circuit block, perhaps being driven from a signal generator - here the timebase would be triggered from the signal generator say applied to the scope's Y1 channel with the circuit's output applied to Y2. Used like this there would always be a display and the triggering controls would not need altering as the Y2 probe is applied on different circuit points to hunt for the signal. A two channel scope can also be used to measure the time difference between waveforms, for sinusoidal signals this will indicate their relative phase; where they are digital signals, time differences between voltage transitions may be caused by propagation delays through gates or excessive capacitive loading etc.. It is usually necessary, with a two channel scope viewing different frequencies, to trigger from the channel having the slower or lowest frequency signal otherwise the timebase will not be able to show all of that slower waveform. Another frill on modern scopes is a delay line in the Y channel(s); this allows the triggering action to start from a particular point on the waveform before that point is actually reached in the delayed version of the signal displayed by the sweep voltage - hence you can see the start or change of some signal before it is large enough to trigger the scope. G3PCJ

### SCR tester by Joseph Bell G3DII

If a constructor contemplates building a power supply unit for a transceiver or power amplifier, then the addition of a crowbar circuit to the unit is a 'must': otherwise Murphy's law dictates that at some time the pass transistor in the PSU will fail and so will the attached piece of gear! The simple circuit below will give an instant indication of a faulty device before it is installed in a PSU to perform the crowbar function.

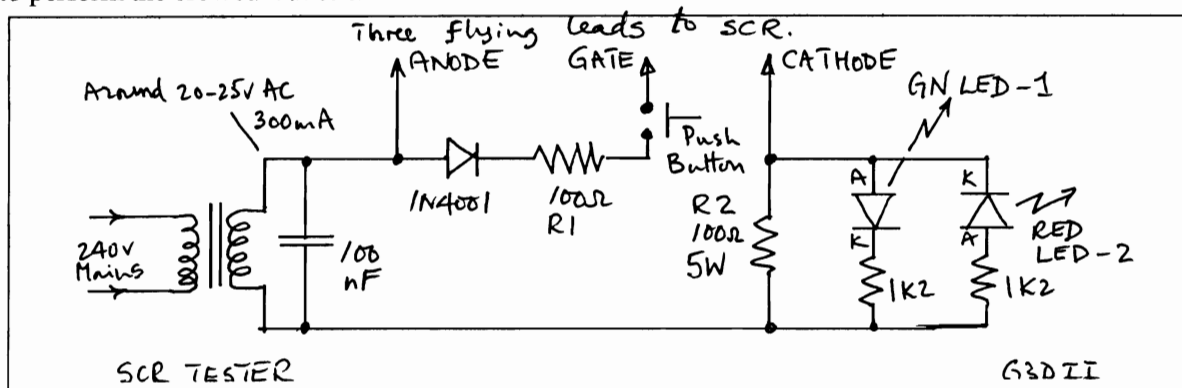

When AC is applied, some 20 v AC will be applied across the SCR but because it should not be conducting, there will be no voltage across R2, hence neither LED should light. When the push button is pressed, SCR gate current will flow and the device should turn on when the anode is positive with respect to the cathode. Thus for half of each cycle, current will flow through R2 so that LED1 (green) will light. If both LEDs light up, the SCR is conducting on both halves of the AC cycle and is internally short circuited. If neither LED lights when the button is pressed, the SCR is open circuit. The unit maybe built in any convenient form with flying test leads for the SCR connections. Applied AC voltage is not critical; an old 6.3 volt valve heater transformer can be used if nothing slightly higher is available. The unit can also be used to test triacs.

## Noise temperature, figures and factors by Eric Godfrey G3GC

In the last issue of Hot Iron I discussed noise and I said at the end that a common way of specifying noise associated with an amplifier or receiver was by stating its "Noise Factor" but that could be the subject of another note. I have now been lent upon by Tim to do such a note and I hope that readers will find this informative. The three parts of the above heading are so interrelated that all three are discussed here rather than just "Noise Factor".

You will recall that in my last note I stated that the noise power was given by the formula  $P_N = kTB^{(1)}$ . Thus the noise is directly proportional to the temperature "T" measured in degrees Kelvin. Absolute zero is  $0^\circ\text{K}$  or  $-273^\circ\text{C}$  and at this temperature all electron flow ceases and no noise is generated. A resistor at room temperature (approx.  $290^\circ\text{K}$ ) would generate, into a matched load, a noise power of  $P_N = 1.38 \times 10^{-23} \times 290 \times B$  i.e.  $4 \times 10^{-21}$  W for every Hertz of Bandwidth over the entire spectrum. Note that the noise power is independent of the value of the resistor but that it is directly proportional to the bandwidth. Consider an amplifier between a resistor and a noise free receiver. The noise at the output of the receiver comprises two components, the noise generated by the amplifier and the noise generated by the resistor amplified by the gain of the amplifier. The noise contribution of the amplifier may be considered as an imaginary increase in the temperature of the input resistor. This is known as the equivalent noise temperature or more usually just the noise temperature of the amplifier. It is worth noting that the noise temperature is not necessarily the same as the physical temperature and in fact in most cases they are different. Amateurs usually talk of the noise factor or noise figure rather than the noise temperature. The noise factor  $F_N$  is related to the noise temperature by the formula  $F_N = 1 + T / 290$ . In the equation the 290 is the normal room temperature of  $290^\circ\text{C}$  i.e.  $290 - 273 = 17^\circ\text{C}$  or  $62.6^\circ\text{F}$ . From this formula it can be seen that when the noise temperature is  $0^\circ\text{K}$  then the noise factor is 1 and for all other temperatures it must exceed 1. More often than noise factor the term noise figure  $N_F$  is used by amateurs which is merely the noise factor ratio expressed in decibels i.e.  $N_F = 10\log_{10}(1 + T / 290)$  or simply  $10 \log_{10}F_N$ .

The above discussion deals with the fundamental side of noise which is very relevant when designing systems<sup>(2)</sup> but in amateur circles the noise temperature is not usually considered but only the Noise Factor or Noise Figure. The Noise Factor and Noise Figure when defined without reference to noise temperature are given by the following two formulae:-

Noise Factor  $F_N = \text{Input S/N} \div \text{Output S/N}$ , where S/N is the signal to noise ratio

Noise Figure  $N_F = 10\log F_N = 10\log(\text{Input S/N} \div \text{Output S/N})$

What does all this mean? Well it clearly shows that in a perfect amplifier, generating no noise in its own right, the Noise Factor will be unity and the Noise Figure will be 0 dB. If any noise is generated then the Noise Figure be greater than 0 dB. So when making or buying an amplifier such as a head-amp or pre-amp one should try to get the lowest Noise Figure possible. It is worth noting that an amplifier set up for maximum gain will usually have a higher Noise Figure than if it is adjusted for minimum Noise Figure. A typical 23 cms pre-amplifier, using a GaAsFET such as the MGF 1024, has near the band centre frequency of 1295 GHz a gain of 14.8 dB and a Noise Figure of 0.55 dB. This is an excellent Noise Figure and is typical of what can be achieved today using modern transistors. It is not so long ago that a typical 144 MHz pre-amplifier using a 6CW4 valve (low noise valve) would have a Noise Figure of about 3 dB.

There should be the minimum of loss between the aerial of any system and the pre-amplifier since any loss will attenuate the signal reducing the signal to noise ratio at its input. Thus a pre-amplifier should be right at the aerial and not at the other end of the feeder. With it at the aerial both signal and noise at the receiver are reduced equally by the loss in the feeder but if it is at the other end then only the signal is reduced.

In conclusion when buying a pre-amp or head-amp always choose the one with the lowest Noise Figure rather than the one with maximum gain.

### References

(1) Hot Iron Issue No. 16. Noise, G3GC

(2) RadCom April, May, June and July 1985. Modern VHF/UHF Front-End Design, G3SEK.



## Class C power amplifiers and filters

Some people are puzzled when they get very little output from a simple CW TX until they add some form of filter prior to the antenna matching unit. Often the reason is that the output stage is operating in class C, without any standing DC current, so that the amplifying transistor is driven into conduction for only part of the whole RF cycle. If the rig does not have any form of 'tuned' load then these pulses of current will produce pulse waveforms full of useless harmonics which often mask the useful carrier. With a tuned load, the pulses of current when the device conducts, make the tuned circuit 'ring' at its resonant frequency so that, when the load is tuned to the same frequency as the driving signal, useful power is produced at the fundamental which can be extracted to the antenna and the harmonics are severely attenuated. This is how the traditional pi matching network of a valved RF amplifier could be used on CW. A Q of 12 used to be recommended to give sufficient harmonic attenuation but nowadays a low pass filter is often suggested to provide extra harmonic attenuation. The 'half wave' low pass filter is easy to remember because the circuit element impedances are made to be equal to the line impedance at the corner frequency where the response is to be 3 dB down. These filters have three elements and two such sections in series will get rid of most harmonics!. Different values are required for each band. The design frequency for the corner frequency should be about 1.2 times the upper band edge so as to not attenuate the wanted signals - they will pass all lower frequencies. The table gives values for the common bands in a 50 Ohm system. The capacitors need to have a voltage rating sufficient for the AC voltage implied by the power through the filter. G3PCJ

Band	$f_c$ - MHz	C - pF	L - $\mu$ H	Turns	Core
160	2.4	1,300	3.3	24	T68-2
80	4.6	700	1.7	17	T68-2
40	8.5	375	0.9	13	T50-2
20	17	180	0.5	10	T50-2
15	26	120	0.3	9	T50-6
10	35	90	0.2	7	T50-6

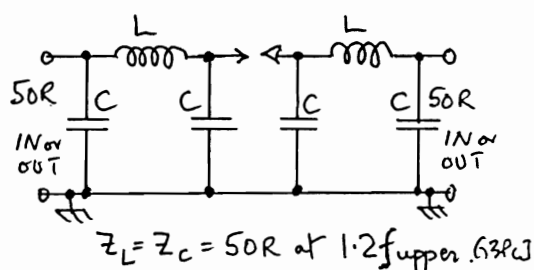

These low pass filters can also be used after a class C amplifier without any internal tuning.

### Reversed supply Yeovil! by John Worthington GW3COI

Some folk never learn! Having built a Yeovil and eventually corrected all my errors I had a happy year using it almost daily on 80m. It even went to VK7 with me as with poor DX conditions, I reckoned 80 m QSOs would suit me well enough during my six week stay. Not only that, it is a very light rig and would keep my hand luggage inside the limit etc.. I was lazy about diode protection from wrong connection to PSUs and having boomed some years ago with another rig I was always very careful. We get a lot of power cuts in Gwynedd and a recent one lasted 12 hours far into the night. I always keep a car battery in the house to operate a light or two etc.; after the fourth hour of no mains I decided to go on air. In the dim light of an oil lamp I fitted the croc clips from the rig carefully on the lugs and heard that dreaded slight frying noise. Realising the truth quicker than the speed of light I started to swear. It was a month before I had recovered sufficiently to tackle the job of repair. Following the designer's advice, I confirmed that two tracks had acted like fuses. I then found that two BC182s had gone o/c. After fitting new ones, I was delighted to find it was working again but only with RIT switched in. As I hardly use this, I disconnected it but found the VFO was jumping 40 Hz or so in a random fashion, especially on CW. Fitting a new CD4093 cured this enough to complete most QSOs but the occasional 'fusspot' would mention it. I found this rather puzzling but Tim's advice was squirt switch cleaner/lubricant on the tuning pots. By the way, the first thing I did before starting on the repair job was to fit a diode in the 12 volt input! My language has now returned to normal!

John, we have all done it! Some are rather keener to keep it to themselves. In such situations a sense of humour is essential. So in tribute, I must publish one of your inventions! G3PCJ

