

Hot Iron

Winter 2003
Issue 42

Contents

- Aerials for /P
- Selectivity
- Counters
- More on DC RX mixers
- Soldering irons and the Windom
- Theory - capacitors and impedance

The Walford Electronics website is at www.users.globalnet.co.uk/~walfor

Editorial

I have come to realise in the last few months that many of the UK's kit suppliers have ceased trading for a variety of reasons - mainly I think because they wished to retire and have a little peace! I wish them all contentment in their chosen leisure pursuits! One of the consequences is that I am increasingly being asked about mating my kits to earlier brand X kit projects! Sometimes this can be done without too much risk so I am always pleased to consider it and give an opinion on the likely outcome. It tends to be easier for accessories because their interface with the main rig is often less complex; it is much harder for transmitters and receivers since these are seldom conceived as independent designs nowadays.

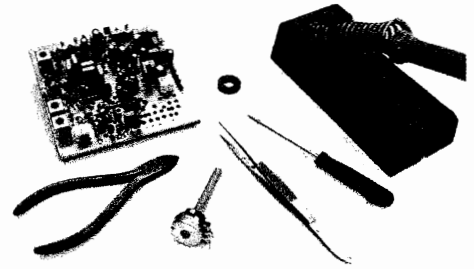

I am pleased to hear of at least two new kit suppliers offering products for our hobby. It is always good to have competition because it keeps all of us on our toes commercially, and it also helps to stimulate new ideas. Their approach is certainly different to mine which can only be a good thing too! You, our customers, are the beneficiaries!

Kit Developments

The **Sidcot CW 80m TCVR** is now fully available having had a write up in the Nov and Dec 2003 issues of PW. It is a specialist CW rig with a strong mixer and many other features that take its performance way beyond that of the 'one transistor does all' CW rigs! £44 plus £1 for P and P.

The dip oscillator project has become the **Dipper** which is now also available; it's a versatile instrument that performs traditional 'dipping' of unknown resonant circuits either by magnetic coupling, or with direct link coupling using its sensing head terminals; the latter can also be used to determine the resonant frequency of an antenna! It can also act as an absorption wavemeter. It covers 180 KHz to 35 MHz normally with ready made coils!! Sensitivity can be improved with your own optional home made coils! It has an output for a counter which works for dipping and absorption. Realising that frequency calibration can be a bit of a chore, I have designed a new **three digit counter** specifically to be mounted underneath the Dipper - see photo later. This gives a readout of XY.Z MHz. It uses a conventional meter as the 'Dipsqueek' notion got too complex! Both are battery powered with a timer. The Dipper costs £44, the 3 digit counter £35 or together they are discounted to £74, with P and P of £2. Tim Walford G3PCJ

Hot Iron is a quarterly subscription newsletter for members of the Construction Club. Membership costs £7 per year with the first issue for each year appearing in September. Those people joining later in the year will be sent the earlier issues for that year. Membership is open to all and articles or questions or comments or notes about any aspect of electronics—principally on amateur radio related topics— is very welcome. Notes on member's experience building their own gear, from kits or otherwise is most interesting to other constructors. To keep it interesting, your thoughts and ideas are required please! For membership, I only need your name and address and subscription. Send it or any other suggestions to Tim Walford, Walford Electronics, Upton Bridge Farm, Long Sutton, Langport, Somerset TA10 9NJ © G3PCJ

Aerials for Portable Use

These need to be as light as possible to facilitate erection particularly if it is a one-man portable operation. For this reason the use of thin aerial wire commensurate with physical strength is desirable. This is against the usual doctrine of using thick wire to keep down losses and improve the bandwidth of an aerial but never the less is very important. Undoubtedly the best form of aerial is the centre fed half wave dipole with the centre as high as possible. This maybe achieved with a single portable mast and sloping wires to supports making the ends of the aerial some five feet or so off the ground. Remember the maximum radiation from a half wave dipole is from the centre and the low ends will only mean that it will have to be pruned to resonance if need be. Do not forget that these low ends are at the high RF voltage points and therefore should be clearly marked with a warning notice if open to the public. The 'mast' at the centre can often be a cord/rope hanging down from a branch of a large tree. The rope may be got over a tree by throwing a weight, attached to which is a thin line, over the branch or better still using a bow and arrow. The thin line is then used to pull up the cord/rope to hold the centre of the aerial. There are many multi-section light weight aerial pole/tubes available but a number of Yeovil Club members have been using the extending (up to 18 ft I believe) plastic fishing rods which have been advertised in RadCom recently.

Assuming that some form of half wave aerial to cover 20, 40 and 80m is required then this may be achieved by joining the inputs of three dipoles cut for each band together at a single feed point and fanned out away from each other to some extent as shown right. The antenna matching unit should be connected by balanced feeder to the central feed point. This can use home made open wire line or commercially made twin feed line.

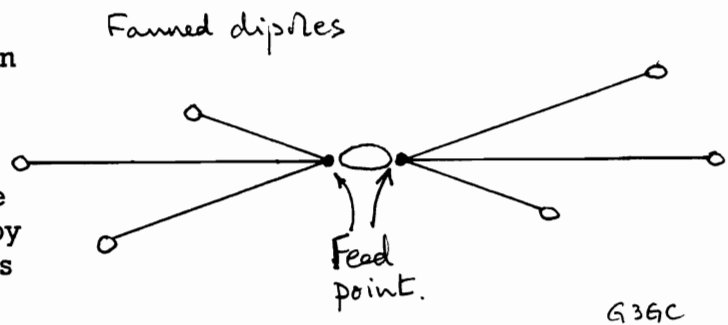

One of the problems with portable working (as opposed to NFD) is that a half wave on 80m is rather large (132 ft) and consequently heavy making it difficult to erect. For this reason, it might be worth considering a centre loaded vertical for 80m. This could be attached to a non-metallic light weight mast or hung from the 'sky hook'. The value of the inductance required will be dependent upon where the coil is placed and the overall length of the aerial. Such aerials have been used in the past for HF mobile working where the overall length of the aerial was limited to about 8 ft. A typical aerial used a coil of 125 μ H with 3 ft below and 5 ft above it. The coil consisted of 67 turns of 18 SWG wire on a 2.5 inch former with turns spaced one wire diameter apart. Connection to the aerial should be via coaxial cable, the outer of which should earthed by an earth stake at the aerial end. One or more quarter wave radials (66 ft) attached to the outer and the earth stake may well improve the radiation efficiency of the aerial. These maybe just laid on the ground. (See right.) The other end of the coax should be fed by the AMU. It is often desirable to join the rig earth/ chassis to the aerial feeder coax screen/ counterpoise(s). (This is not recommended for safety reasons, if the rig is mains powered - G3PCJ)

Centre loaded vertical for 80m

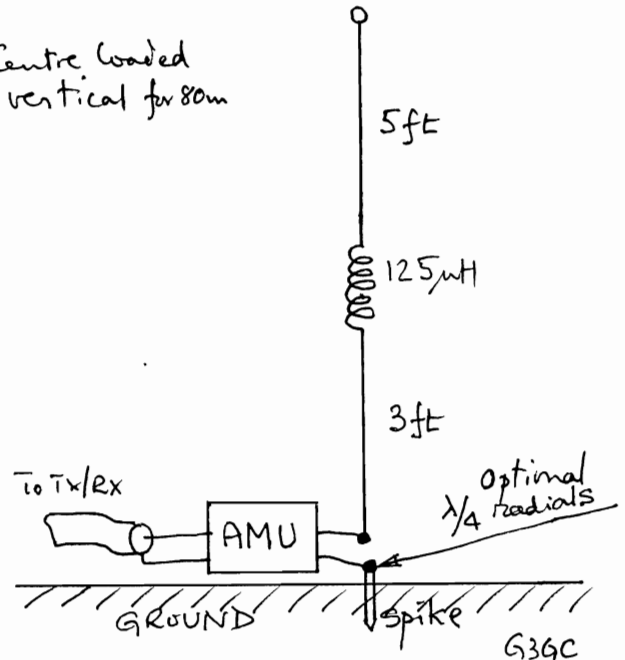

Horizontal loop aerials are always very useful and should preferably be made a wavelength long that maybe in the form of a square with 33 ft sides for 40m. However, provided the matching unit will cope, they do not have to a wavelength long or four sided but may take up a whole variety of shapes and sizes. They may be used in a vertical, horizontal or sloping configuration. The radiation pattern will be more or less unpredictable due the wide range of options. Continued over...

Portable aerials continued

As before, the aerial should be connected by balanced feeder to the AMU. If the AMU cannot cope with the input impedance, then quite often increasing the length of the feeder will make it come within the scope of the AMU - this has to be done by trial and error. If the loop is in the form of a triangle or diamond in the vertical plane then the 'sky hook' may be used to hold up the vertex with the ends of the horizontal sides taken to low supports as shown below. The feed can be in the centre of the base wire or offset to one corner but this will alter the radiation pattern.

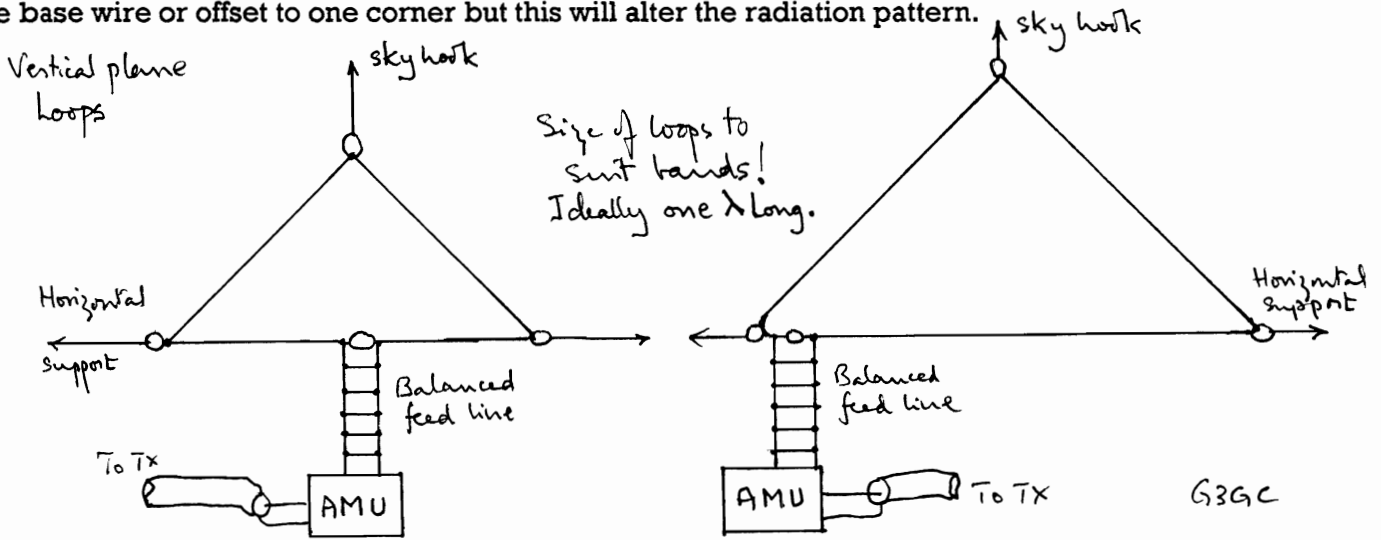

Another possibility is the use of a trap dipole but due to the weight of the traps reasonably thick wire is required which also adds to the overall weight. The aerial shown below was featured in SPRAT and is described as a loaded dipole for 10 to 80m. This aerial is 52 ft overall with loading coils 6 ft in from the ends. The coils are wound on 2.5 inch plastic formers using 55 turns of 18 SWG wire spaced one diameter apart. The weight of these coils will require a reasonable size of aerial wire.

I used to operate a lot portable whilst on holiday and used an end fed quarter wave supported by an ex-RAF sea rescue box kite. These kites fold up to go into a tin some three inches in diameter and about two feet long to which the kite string is attached. (I still have one somewhere! G3PCJ) The great thing about these kites was that there was never any problem in getting them airborne. If I couldn't get a stake into the ground I used a quarter wave radial. Modern kites maybe even better! As an aside, helium balloons were also popular in the fifties and sixties as sky hooks for 160m quarter wave vertical aerials.

A final general remark about portable working on the HF bands and particularly the lower frequencies. It is far better to choose a site with a good water table rather than a high site on poor ground. Typically, Caradon Hill, the site of the ITA/BBC TV station in Cornwall is a very good site for VHF/UHF but is useless for HF since it is on granite which is a good insulator.

Eric Godfrey G3GC

Loaded dipole for 10 to 80m - after SPRAT

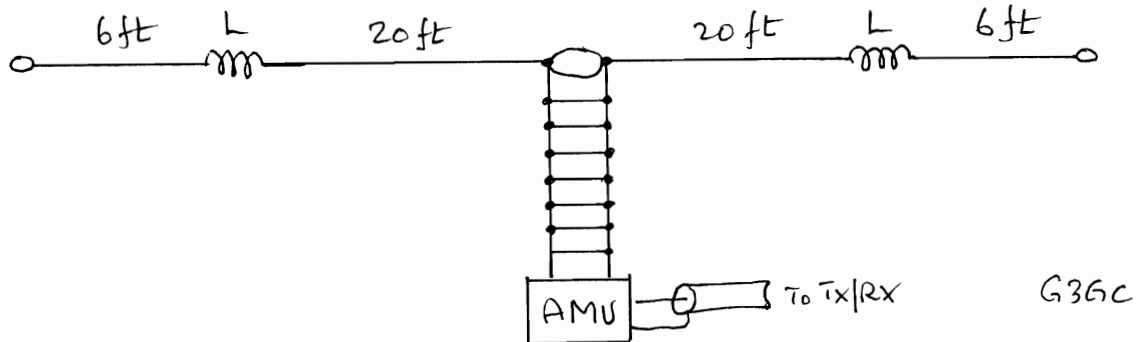

The Three S's - selectivity

This is the second aspect and concerns the ability of the receiver to hear the wanted signals while rejecting all the mass of unwanted ones! The main point is that the receiver's bandwidth should be wide enough to pass all of the 'information' in the wanted signal. This depends on the mode being used. For voice, the important range lies between roughly 300 Hz and 3 KHz. The ear's ability to understand a 'message' is not materially impaired by removing both the small amount of information below 300 Hz, and the considerable high frequency content over 3 KHz. A good *communications* transmitter will contain filters to restrict the audio range to roughly 300 Hz to 3 KHz, whereas a *broadcast* transmitter would be instantly taken off air if it wasn't passing the full range of the audio material (and probably more!). Restricting the range of the modulating audio directly reduces the RF bandwidth needed so allowing more 'channels' within a given RF band. (Complex coding, eg MPEG, can reduce the bandwidth even more!) In difficult conditions, where there is high adjacent channel interference, it is often advantageous to ignore even more of the high frequency content of the voice by limiting the bandwidth down to as low as 2 KHz; this can improve the 'understand-ability' but will detract from the natural vocal qualities of the person on the mike! (Note that 'speech processing' does NOT usually alter the signal's audio frequency range, but instead raises the *average level* of the signal compared to the *peak level* - but that's another subject!)

For morse or interrupted carrier signalling, the frequency content of the information is much lower because it is a simple manual on/off system. High speed morse implies an information bandwidth of roughly 100 Hz but to convey this information we actually listen to it anywhere in the audio range - often between 500 and 1000 Hz because our ear/brain work as a good filter thereabouts! Filters centred on 800 Hz are often used but many like it lower; I use 723 Hz because it comes directly from standard value capacitors and resistors! A good CW receiver will have audio filtering with a bandwidth down to 150 Hz; but if it is much lower than this, the implied filter Q will be too high causing the filter to 'ring' which is uncomfortable to listen too. Wider CW filters are desirable for searching the band, because it is very easy to miss a signal as you tune quickly across the band using a very narrow filter; having found something, then is the time to use the narrow one.

The above 'filtering' can be done at baseband (as audio), and or with filters before the demodulator at RF, and IF in a superhet. The narrowest *bandwidth* filter in the rig determine the characteristics, however a really narrow tuneable RF filter is impractical so that in a DC rig, the audio filters alone (almost always) determine the receiver's bandwidth - hence their importance. The sharper the *slope* of these filters (more poles and more complexity), the better it will be able to reject strong adjacent channel signals - see the curves right for a good and poor audio filter! The important filters will usually be low pass, humped low pass or bandpass because most of the unwanted signals are higher in frequency than the wanted one.

The main role of IF filtering (if fitted) is to increase the effective slope of the audio filters (so improving near signal rejection) without reducing the bandwidth. The slope of the response on the sides of an IF filter is directly related to the number of poles or resonators/crystals within it. The IF filter can also remove the unwanted sideband, both for reception and transmission since this cannot be done easily with an audio filter. The role of the rig's RF filter is to remove excessive signals outside the desired RF band, so preventing overload - notably of the important and tender first mixer - and also to reduce the image response at twice the IF from the wanted signals. Good selectivity comes from a combination of all these aspects! The lower diagram depicts the relative contribution from all the rig's filters. Next time I will write about keep^{ing} the rig on tune! G3PCJ

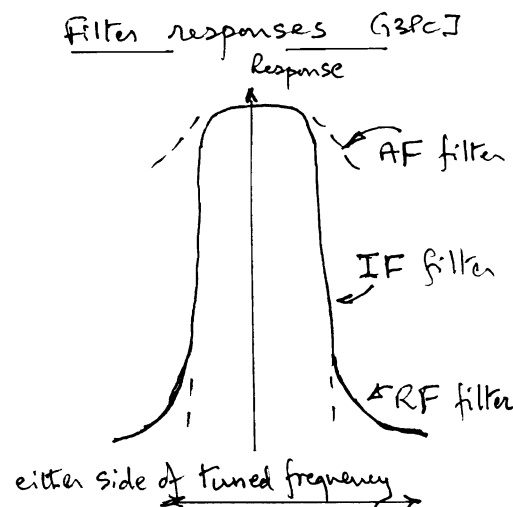
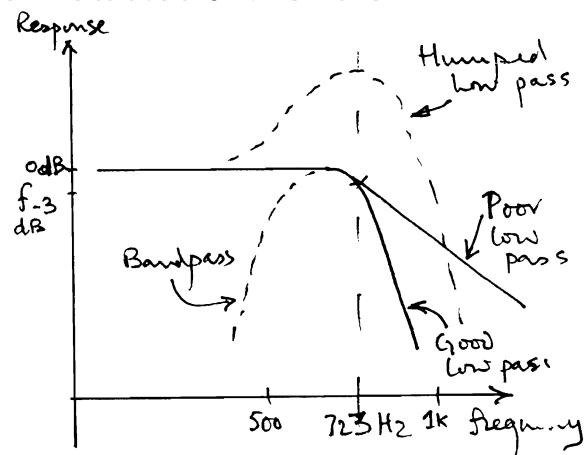

Counters

I rate having a counter pretty high up my test equipment list; for most people I suggest it should come not far after acquiring a good general purpose multi-meter. General purpose factory made new ones can be bought for a reasonable price now, and often bulkier older ones are available very cheaply at rallies. Coupling these permanently to a rig is wasteful (and often does not work well) so dedicated counters should also have a place in your shack or rigs!

The first point to note is that all designs use digital techniques internally, and some of the cheaper ones will also have multiplexed drive to the LED displays. This approach involves moderately high currents being turned on and off rapidly in the low KHz region so is a prodigious source of RF interference! The reference clock and its harmonics can also be troublesome. A counter designed specifically for use in a receiver should be electrically quiet so that it does not mask wanted signals. This is possible by using CMOS digital circuits kept all close together on a good ground plane with plenty of supply decoupling. The quickly changing currents in such logic circuits (which cause the unwanted radiation) mainly charge/discharge the track capacitance, so small size helps appreciably. With direct drive to LED displays (not multiplexed), these connections carry DC and only change when the frequency is altered; so they do not radiate and don't have length or layout restrictions. Micro-processor based counters, all though versatile, are also often electrically noisy!

The diagram right shows the basic concept of a counter. A reference clock oscillator is divided down and opens a gate for a defined period. This directly determines the value of the least significant digit (LSD). For example, if the gate opens for 1 millisecond, the LSD will be units of KHz. When the main counter driving the LSD display overflows past 10, the next more significant digit increases by one etc.. The number of counter stages and displays determine the upper displayed frequency BUT note that the logic might not be able to work as fast as that! Often a pre-scaler counter is used to reduce the input frequency. If this divides by 10 say, then the LSB will become 10 times larger. The main counter stages and displays for any upper frequency capability, do not have to be present; if missing, the more significant digits just disappear out of sight leaving the only KHz part of the incoming frequency for our above example!

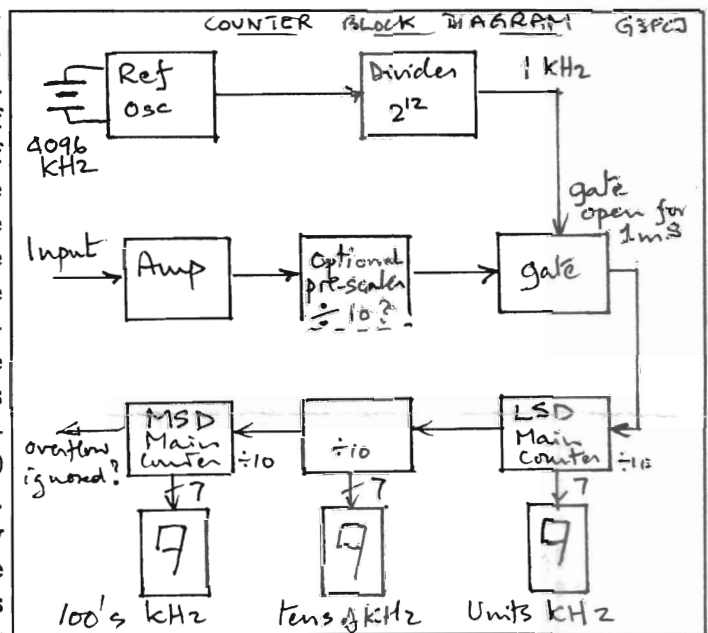

To cater for IF offsets in superhets, you can make a counter accept two inputs (from the LO and CIO) with the counter adding or subtracting to match the action of the rig's mixer - as in my 5 digit design. The new three digit unit is shown right mounted below the Dipper.

In this role it normally shows the XYZ MHz part with an upper counting limit of about 65 MHz. For use with DC rigs, by altering some wire links, it can alternatively show the important UVW KHz only part of the incoming LO frequency - the MHz bit having overflowed out of sight. The display section can be relocated to the rig's front panel with the logic PCB then occupying just 50 x 80 mm. It is also able to count up or down so will suit additive or subtractive superhet rigs having integer MHz IFs. (Because the erroneous MHz digits are out of sight!) G3PCJ

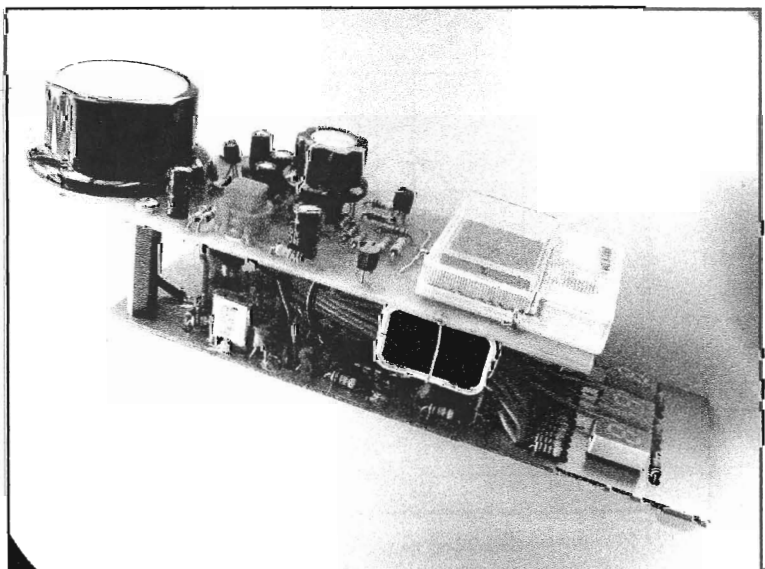

More on mixers for DC RXs!

Last time (page 5 of HI 41) I sketched the basic circuit of the detector in the Sidcot. This switching mixer has good signal handling ability but its drawback is the need for a tri-filar wound toroid; inexperienced builders don't care for winding such things but it is not really that difficult. It would be nice to find another way of providing the necessary anti-phase RF signals. Providing the other anti-phase LO signals is easy if they are digital since it only requires another gate in the LO chain. The Sidcot circuit (right) has a toroid to produce the RF signals feeding into 'grounding' switches so that the AF is developed at the toroid's centre tap, which then feeds a resonant step up circuit to the AF amplifier.

This scheme has the frequency response shown right so is ideal for a CW rig but is not much use for a phone receiver needing a flat response over a band from 300 to 3000 Hz. It does have the advantage of providing audio voltage gain without any potentially noisy active devices, so is inherently low noise and sensible for incorporation in the early stages of a high gain DC rig. (One does need to be a little careful about possible magnetic coupling into the inductor's core though!)

Another approach is to draw the AF directly from the switches rather than the RF transformer centre tap. This is shown in notional form right and has to be used if the two RF anti-phase signals are ground referenced, such as from an active phase splitter stage having equal value resistors in the source and drain of an RF buffer. (The DC biasing is a little more complex in reality.)

By using a JFET RF buffer connected directly after the RF bandpass filter, one can take advantage of the high impedances in the tuned circuits to realize some RF voltage gain at the same time as the phase splitting. This leads to a front end like that shown below. I emphasize I have yet to try this but it does look promising! Its my next practical job to try this for the Locking! Do let me know if any of you try it out yourselves! G3PCJ

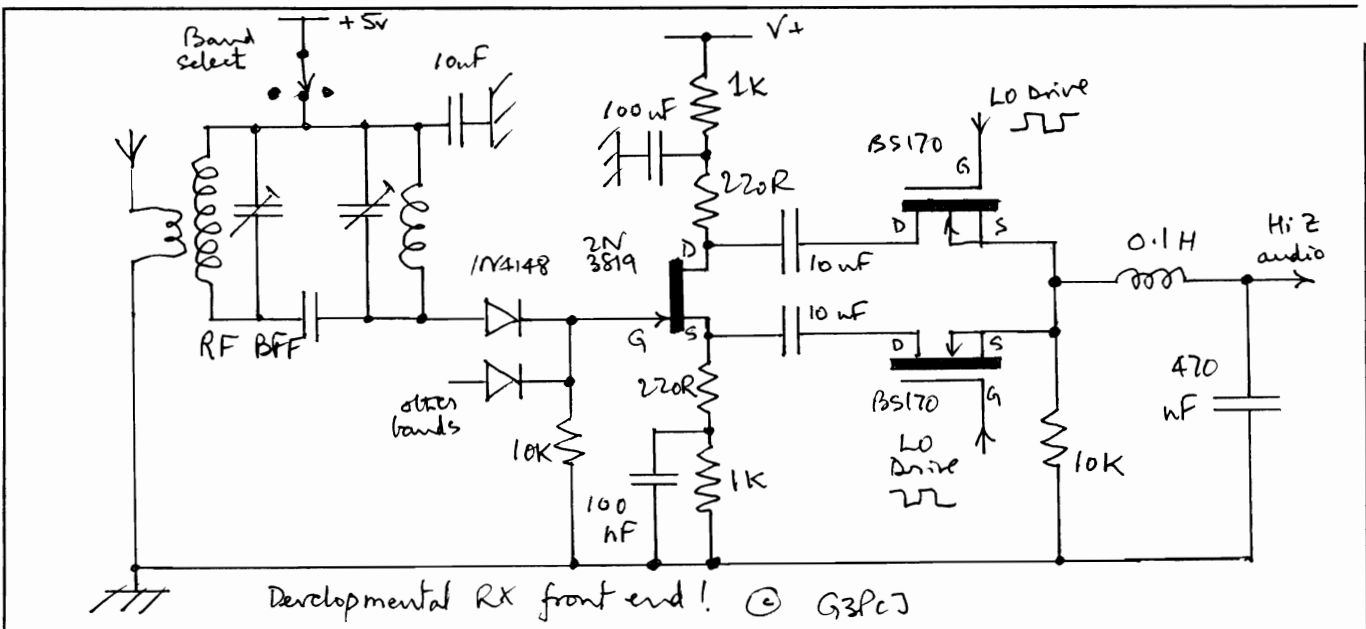
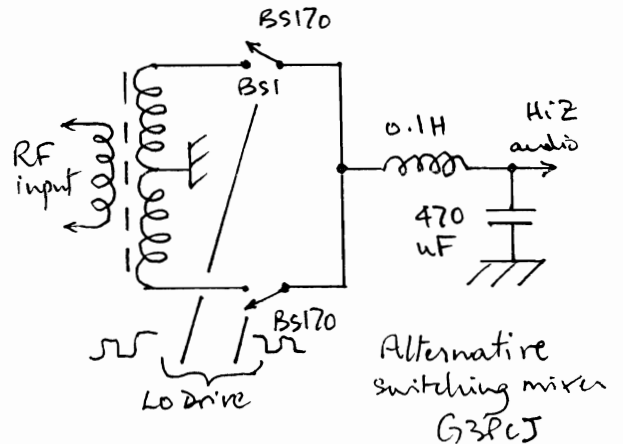
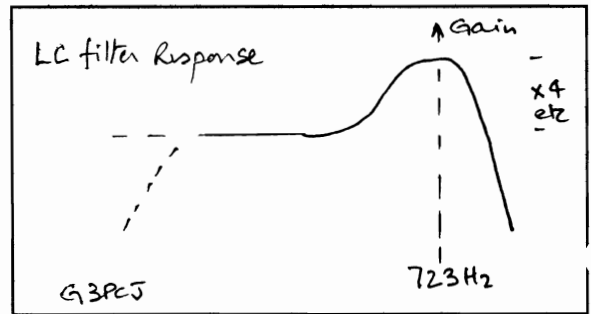
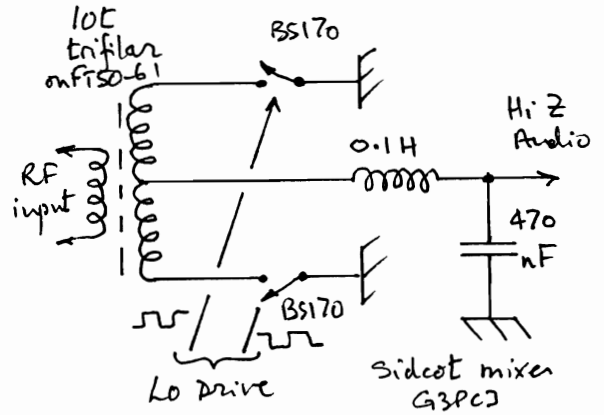

Big soldering irons

Last time I showed you a picture of a collection of large irons and posed the question of who was the previous owner. Two readers responded; Stan Pilkington suggested that they had not come from Walters and Stanton at a recent rally (!) but might have a connection with the demise of Wooferton. Dave Buddery suggested the owner was VS1AA - see below. Both were original suggestions but neither was quite right - I was vaguely hoping that somebody might suggest Marconi knowing my interest in the Cable and Wireless beam radio station that used to operate nearby at Somerton. The station was originally built by Marconi for the Post Office and they were part of the aerial rigger's tool kit - I retrieved them from the scrap bin along with this range of aerial and feeder insulators when it was being dismantled by BT recently. Sorry - no prizes, just the glory of getting a mention!

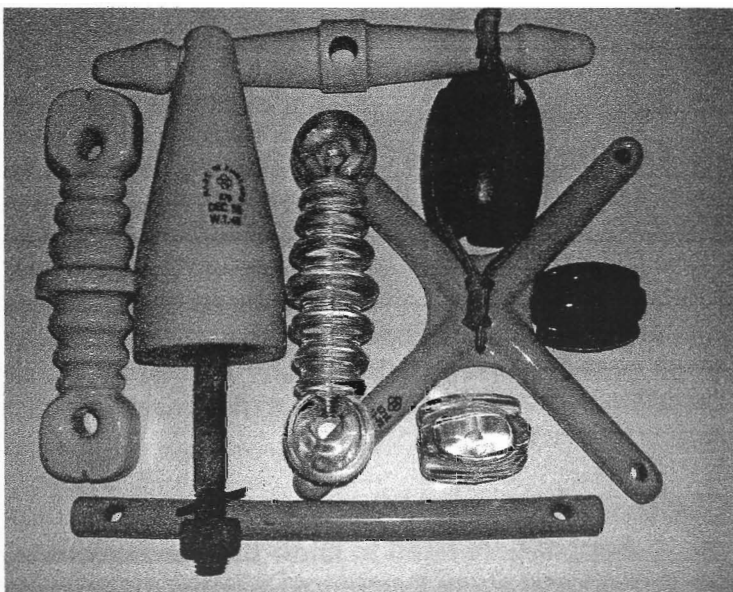

The Windom and VS1AA

Dave Buddery G3OEP suggested that the tools belonged to the late Ken Mackintosh VS1AA because he had observed that I did not include, in the photo, any insulator for the centre of a dipole! The Windom is one of the few aeriels that is a single length of wire, hence the tools were likely to be associated with the Windom and remote places. VS1AA was an expert on the Windom (maybe the only one?), who worked for many years as a rubber planter in Malaya - probably with limited electricity supply hence the large fire heated irons. During the thirties he described an improved 1-V-1 receiver with an extra 4th valve which he called the 'reactor valve', this was a tuneable oscillator covering the RX's bands, in effect he had constructed an early DC RX.

Dave calls the Windom, the 'Croquet antenna', because it resembles the game many consider outdated and played by effete Victorians on Vicarage lawns. The reverse is the case! (I play in a local fun tournament held close to Somerton RS - no further comment please! G3PCJ) Both are complicated and require skill for best effect. The length of the top must be correct, the tapping point is critical and the feeder must fall vertically from the top. Too many put up a crudely measured bit of wire, attach a feeder inaccurately and don't let it fall away vertically - they then wonder why it is disappointing. Ken said that if the feeder is made from wire about two gauges thinner than the top, the aerial will work better on the second harmonic.

Dave thinks the Windom is good for field days as it can be pre-measured and the operating caravan or tent can generally be placed vertically beneath the feed point, and if you are lucky enough to be situated on a damp Norfolk marsh you can easily find a good low resistance earth. Dave asks if this also applies to the Somerset Levels? Yes, but I have no experience of the Windom! As ever, with a single unbalanced feed, a good RF earth system is critical.

Long wire aerial material

You might care to consider livestock electric fencing 'string' - actually multi-strand plastic twine with embedded conductors. One has 6 strands of copper 0.25 mm wire. Under £10 per 200m!

20th Yeovil QRP Convention 2004

Make a note in your diary now! The date is April 18th 2004 and will be held at the Digby Hall, Sherborne, Dorset. This is the same venue as has been used for several years. Contact Derek MOWOB for details on 01935 414452 or via e mail to mowob@tiscali.co.uk There will be the usual range of talks and traders etc. etc.. A great day out with the minimum of distracting non radio electronics!

Theory!!

I can hear the groans already! Andy Howgate suggested I dissect a formula or two to make them more useable. What a task to give me! First lets try capacitors.

Its worth just reminding ourselves of the relationship between different units of capacitance. The basic unit of capacitance is the Farad but it's a huge amount of C - in practice only made as temporary standby energy storage devices for semiconductor memories; most capacitors are tiny fractions of a Farad. Often what we think of as 'large' caps are marked in micro-Farads, usually written as μF ; medium sized ones in nano-Farads, usually written as nF; and small sizes are in pico-Farads, usually written as pF. Their relationship is shown right.

Capacitive reactance

Suppose we need to know the reactance of a particular capacitor at some frequency. We use the following basic formula:-

$$X_c = \frac{1}{2\pi fC}$$

X_c in Ohms
 f in Hz
 C in Farads

The above formula also holds for frequency in MHz and capacitance in micro-Farads. It can be modified thus:-

$$X_c = \frac{1,000,000}{2\pi fC}$$

X_c in Ohms
 f in MHz
 C in pF

As an example, I have listed the steps right on my scientific calculator, to find out the reactance at 10 MHz of a 220 pico-Farad capacitor. Answer 72.38 Ohms

Sometimes we need to work out the capacitor size needed for a given reactance. The above formula is shuffled around to become:-

$$C = \frac{1,000,000}{2\pi f X_c}$$

C in pF
 f in MHz
 X_c in Ohms

Again the scientific calculator steps are listed right.

$$1 \mu\text{F} = 1,000 \text{ nF} = 1,000,000 \text{ pF}$$

$$= 10^6 \text{ pF} = 10^{-6} \text{ Farad}$$

$$1 \text{ nF} = 1,000 \text{ pF} = 10^{-9} \text{ Farad}$$

$$= 10^3 \text{ pF}$$

$$1 \text{ pF} = 10^{-12} \text{ Farad}$$

A capacitor marked 103 is
 $10 \times 10^3 \text{ pF} = 10 \text{ nF}$

G3KJ

Key-strokes	Display
1	1
0	10
0	100
0	1000
0	10000
0	100000
0	Entered 1,000,000
÷	operator
2	2
÷	operator
500000	500 000
3	} decimal point 3. Value of π 3.14
1	
4	operator
159235.6688	159 235.6688
1	frequency
10	10 in MHz
÷	operator
15923.56688	159 23.56688
2	capacitv
220	220 in pF
=	calculate
72.3798	72.3798 Ohms

1000000	Entered 1000000
÷	operator
2	2
÷	operator
500000	500 000
3.14	Value of π
÷	operator
159235	159 235
10	frequency in MHz
÷	operator
72.38	Reactance in Ohms
=	calculate
219.99	219.99 pF

Please remember I am always looking for material for Hot Iron! I can use any questions as well as rough articles, or most things related to amateur radio with a mildly technical flavour! Its early, but HAPPY CHRISTMAS!