

40TH ANNIVERSARY ISSUE

# QRP Quarterly

April 2001 • Volume 42 • Number 2

\$4.95

Journal of

QRP Amateur Radio Club

INTERNATIONAL

## PSK31: Brit Style

Special Focus on  
ANTENNA SYSTEMS

Out in the cold  
WITH THE CHEESEHEADS

N0UR-OO Contester  
OF THE QUARTER

FT-817  
REVIEW BY K9QI

QRP ARCI is a non-profit organization dedicated to increasing worldwide enjoyment of radio operation, experimentation & the formation/promotion of clubs throughout the world.

## NEW From Patcomm



### The PC-500 Dual Banders

For **\$395.00** you get lots of built-in features such as both **CW& SSB** modes, an **Iambic Keyer** with our **patented CW Keyboard Interface**, adjustable **1 to 15 Watts** of output power and Patcomms' unique **DVF** (Digital Variable Filter) filtering system providing a 600Hz to 2.8kHz continuously variable filter within the AGC loop for superb receiver selectivity. **VOGAD** and **RF Clipping** are used on SSB Transmit to provide that **Big Radio "Punch"**. This radio can be ordered with your choice of any two Ham Bands between **160 and 6 Meters**, and when ordered with the **VOX** option is **PSK-31** ready. This is the ideal rig for **QRP** and **Portable** operation. **ALL THIS FOR ONLY \$395.00**

**I can't believe it's not a kit !**

### New Lower Prices on these Patcomm Radios



#### PC-9000 HF+6 Transceiver

Compact, rugged 40 Watt Ham Band Transceiver with our unique DVF (Digital Variable Filter) continuously variable filtering system and our **patented CW Keyboard Interface**. You get coverage of all HF Amateur Bands plus 18 Watts out on 6 Meters. Low power mode lets you operate QRP at 5 Watts output.

**Reg \$799.00 (FM Adapter \$79) Now \$650.00 Incl FM Adapter !**

#### PC-16000A HF Transceiver



**Reg \$1,749.00 Now \$1,295.00**

**100 Watt** with General Coverage Receive. **Collins IF Filters** and **DSP Audio Filtering** make this an exceptional rig. DSP features include 5 "Brick Wall" filters plus Auto Notch and a De-noiser. Other features include our built-in **patented CW Keyboard Interface** and automatic CW and RTTY Decoder. Operates on CW, SSB and AM with output power adjustable from **1 to 100 Watts**. Here is a full featured rig which is easy to use and delivers solid performance.

**patcomm**  
-corporation

Phone: (631)862-6511  
Web: [www.patcommradio.com](http://www.patcommradio.com)  
7 Flowerfield Suite M100

Fax: (631)862-6529  
E-mail: [patcomm1@aol.com](mailto:patcomm1@aol.com)  
St. James, NY 11780

NEW MATH



### Miniature Paddle Key

Model PK-1

\$42.50 +



### Lambic Keyer

Model K-4

\$48.95 =



### Key/Keyer Combination

Model KP-4

\$84.00

Excellent feel, fast, rugged.

Fine pitch adjust screws.

Magnetic bottom with 2 mates, RFI filter & 3' keyline. Only 1" x 1-3/4"; 1.5 oz.

Knee mount available.

(Add \$2.25 shipping)

12 functions with two 50 character

memories. Has beacon mode,

4-year battery and RFI filter.

1-1/2" x 2"; only 1 oz.

1/8" mono & stereo jacks.

(Add \$2.25 shipping)

All the features of the Models PK-1 and K-4 in a lightweight, precision machined case.

1-1/2" x 2"; only 1.7 oz.

Knee mount available.

(Add \$3.25 shipping)

Send check or M.O. to: Paddlette Co. \* P.O. Box 6036 \* Edmonds, WA 98026. Sorry, no credit cards.

Shipping by U.S. Mail, first-class. Info: Bob, K17VY, Tel: (425) 743-1429, E-mail: bham379627@aol.com



# MORSE Express

A Division of Milestone Technologies, Inc.

"Everything For The Morse Enthusiast"

- ✓ Keys
- ✓ Paddles
- ✓ Bugs
- ✓ Keyers
- ✓ Software
- ✓ Kits
- ✓ Books
- ✓ Tools

[www.MorseX.com](http://www.MorseX.com)



Free Catalog

**303-752-3382**  
2460 S. Moline Way  
Aurora, CO 80014

# QRP Books

Quality Books for the Low Power Enthusiast

Antennas ♦ RF Design ♦ Reference Manuals  
Operating ♦ Proceedings ♦ Measurement

21 Myers Heights Road Lansing, NY 14882

[www.QRPBooks.com](http://www.QRPBooks.com)

## Kanga US

New Products Available at Dayton:

- Hands Electronics RTX-109 - All Band SSB/CW Transceiver--6 or 20W version.
- R2Pro by KK7B - High performance DC RX module.
- DK9SQ Folded Vertical - All bands 80 - 10 including WARC. No Traps!
- Tormet Electronics VFO Module in a Clock Oscillator Module.

Coming soon from Hands Electronics:

- Monoband xcvr for PSK31/MFSK/RTTY for any band 3.5 - 50 Mhz

Still available:

- Spectrum Analyzer and Tracking Generator by W7ZOI and K7TAU
- R1, miniR2, T2, and LM2 by KK7B
- DK9SQ Mast, Loop, and Dipole
- Kits from Kanga Products, Hands Electronics, and Sunlight Energy Systems



Kanga US  
3521 Spring Lake Dr.  
Findlay, OH 45840 419-423-4604  
[www.bright.net/~kanga/kanga/kanga@bright.net](http://www.bright.net/~kanga/kanga/kanga@bright.net)

# Table of Contents

**Page-17**

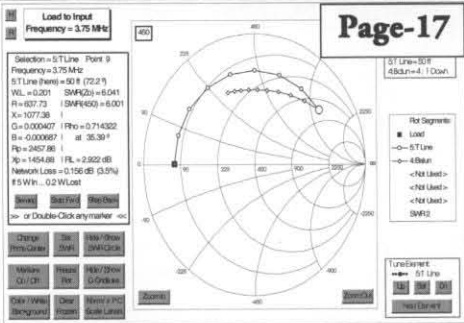

Loaded Input Frequency = 3.75 MHz

Selection = ST Line Port 9  
Frequency = 3.75 MHz  
ST Line Item = 50 # (72.2°)  
VIL = 0.209 SWR(2) = 6.041  
R = 627.73 (SMF450) = 6.001  
X = 1077.38  
G = 0.000407 (Rn = 0.714352)  
B = -0.000667 (at 35.39°)  
Rp = 2457.86  
Rn = 1454.88 (RL = 2.022 dB)  
Network Loss = 0.156 dB (3.5%)  
# SWR = 0.2 W/Loss

For Segments:  
- Load  
- ST Line  
- SWR  
- For Load  
- For SWR

Tune Segment  
- ST Line  
- SWR



**Cover Story--Dick Pascoe--G0BPS gives us a more global perspective on PSK-31.**

## Technical

- 6 Idea Exchange—Mike Czuhajewski—WA8MCQ:
  - Joe's Quickie No. 37: A Homebrew Twinlead Connector—Joe Everhart—N2CX
  - Adding 2nd 8V Reg. to Improve NorCal-40A Freq. Stability—Larry East—W1HUE
  - Modifications for the MS-15 Transceiver—Steve Weber—KD1JV
  - ALTOIDS Tins in Various Sizes—Dick McIntyre—K4BNI
  - More on the Upcoming MN9 QRP Kit—Frank Nance—W6MN
  - Six Volt Gel Cells Charged from 12 Volts—Sam Billingsley—AE4GX
  - Locating an Open Circuit in Coax—Arthur Edang
  - View Sine Waves with Better Resolution—Mike Czuhajewski—WA8MCQ
  - On-Line Notes on the SST Transceiver
- 13 The CSS Receiver—Larry Stambaugh—WB0RMT
- 14 A Simple Multi-Band Attic Antenna—Victor Dively—KG4HTT
- 17 Picturing the Rest of Your Antenna System—Dan Maguire—AC6LA
- 22 A Versatile Remote Control Antenna Tuner—John Cumming—VE3JC
- 29 Some Comments on Powering the Yaesu FT-817—Barry Johnson—W4WB
- 35 A Switchbox for Soundcard Digital Modes—Don Wilhelm—W3FPR
- 39 How to Build KwiKits—Denny Baker—W9OCP
- 44 QRV? Which Kit to Buy? Yes!—Mike Boatright—KO4WX
- 50 Test Topics...And More—Joe Everhart—N2CX

## Operating

- 13 Milliwatt Triple Crown Winners
- 21 Confessions of a NEW DX HOUND—QRP STYLE—Steve Melachrinis—W3HF
- 32 PSK31 "Across the Pond"—Dick Pascoe—G0BPS
- 38 Using the FT-817 in the PSK-31 Mode—Barry Johnson—W4WB
- 42 Contest Operator of the Quarter—Jim Lageson—N0UR (by Randy Foltz—K7TQ)
- 46 Adventures in Milliwatt—Shortened 80M Vertical—Jim Hale—KJ5TF
- 52 Out in the Cold with the Cheeseheads—Craig Behrens—NM4T
- 57 QRP Contests—Randy Foltz—K7TQ

## Reviews & Product Announcements

- 16 Patcomm 500—A Quickie Review—Jim Stafford—W4QO
- 24 New Mini-Paddle Announcement—Johannes Hiller—DL9SCO
- 25 My Thoughts on New Yaesu FT-817 QRP Transceiver—Greg Buchwald—K9QI
- 47 New Product Announcement—KK7B R2Pro Receiver Module kit—Kanga U.S.

## Columns and Departments

- 3 Editor's Spot—Craig W. Behrens—NM4T
- 5 Base Current—Jim Stafford—W4QO—QRP ARCI President
- 30 QRP ClubHouse—Les Shattuck—K4NK
- 31 Ramblings of a Peaux Displaced Cajun Lad in Maine—Joel Denison—KE1LA
- 47 QRP ARCI Awards—Thom Durfee—WI8W
- 48 Remember When—Les Shattuck—K4NK
- 49 Profiles in QRP—Rich Arland—K7SZ

## Miscellaneous

- 4 QQ Correspondence
- 5 Four Days in May—Announcement
- 37 FDIM or Bust—Cycling to Dayton Announcement
- 54 How to Host Your Own Pixie Party—Victor Gann—W4VEG
- 63 Application for ARCI Membership
- 64 IMHO—QRP & California Power—Wayne Burdick—N6KR
- 64 The Last Word
- Inside Back Cover—Four Days in May Registration Form

## QRP QUARTERLY EDITORIAL STAFF

Editor

### **Craig W. Behrens—NM4T**

520 Browns Ferry Road  
Madison, AL 35758  
craigwb@hiwaay.net

Associate Editor & Features

### **Larry East—W1HUE**

15355 S. Rimline Dr.  
Idaho Falls, ID 83401-5917  
w1hue@arrl.net

Associate Editor & Idea Exchange

### **Mike Czuhajewski—WA8MCQ**

7945 Citadel Drive  
Seyern, MD 21144-1566  
wa8mcq@erols.com

Associate Editor (Contests)

### **Randy Foltz—K7TQ**

809 Leith Street  
Moscow, Idaho 83843  
rfoltz@turbonet.com

### Regular Columnists:

QRP Clubhouse & Remember When

### **Les Shattuck—K4NK**

112 Park Circle  
Greenville, SC 29605  
k4nk@aol.com

Milliwatting

### **James L. Hale—KJ5TF**

HCR 65 Box 261B  
Kingston, AR 72742  
kj5tf@madisoncounty.net

Profiles in QRP

### **Rich Arland—K7SZ**

25 Amherst Avenue  
Wilkes Barre, PA 18702  
k7sz@epix.net

QRP

### **Mike Boatright—KO4WX**

1280 Ridgecrest Lane  
Smyrna, GA 30080  
ko4wx@mindspring.com

Test Topics...and More

### **Joe Everhart—N2CX**

214 NJ Road  
Brooklawn, NJ 08030  
n2cx@voicenet.com

peaux displaced cajun lad...

### **Joel M. Denison Sr—KE1LA**

POB 542  
Strong, ME 04983-0542  
hamjoel@juno.com

## From the Editor's Desk

Craig W. Behrens--NM4T

craigwb@hiwaay.net

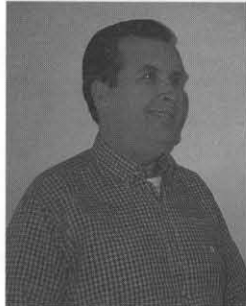

QRP is a lot of things to a lot of people. QRPer, as a whole, are an interesting lot, capable people from all walks of life in active pursuit of diverse amateur radio adventures. We are creative, constantly building equipment and operating in unusual ways. We are constantly learning new skills and finding intriguing ways to share new experiences. Our talented QQ staff captures bits and pieces of the beautiful spirit. We wrap it up in this little magazine and promptly ship it your way.

Per QQ tradition, this issue will help the die-hard gear heads enter into the analytical mode and figure-out once and for all how that antenna system actually works (or why it doesn't). Learn how to squeeze all of the performance possible out of your Stealth and/or attic antenna system. Implement the PSK-31 hardware needed to get on the air. Understand just what kind of rig the FT-817 is. And...there are new goodies to build!

### **But, wait, there is much, much more!**

You need to be sure you have a spot of tea with tasty crumpets while **Dick Pascoe, GOBPS**, takes you on a PSK-31 journey—Brit style. Shiver a little while the **Cheeseheads** take you out into the cold on FYBO adventures. Jump into the middle of the chaos of a pack of jubilant and energetic scouts mass-building Pixies. Get out your knitting needles and stitch-up a Kwikit or two. Pay homage to one of our great operators as you enter **Jim Lageson's, N0UR**, shack. Figure out how **Les Shattuck, K4NK**, worked all that QRP DX. Find out how you ranked amongst fellow radio warriors in the Contesting section. And enjoy the many little serendipities scattered through the pages for your enjoyment.

The list goes on. Design, build, modify, operate, and chase adventure—so much to do so much fun to be had!

As you can see, your magazine is very utilitarian in its layout design. Even so, it is difficult not being able to include all the great contributions we receive. I feel I must apologize to all who didn't get their piece into this April issue due to physical constraints.

We switched over to the Adobe Publishing Software Suite as a part of our continual improvement quest. (We're still figuring out how to do this publishing business.) This professional grade software provides us with amazing new capabilities and makes our printer a much easier guy to get along with. Thanks to my staff for bearing with me and for your patience.

Welcome two new members to our elite little group of QQ advertisers: **Kanga** and **The QRP Book Store**. Be sure to check out their offerings and new product reviews. (A limited number of business card size ad spaces are available for members to advertize club activities, Ham fests, etc.)

I would like to offer a special thanks to **Brian Murrey—KB9BVM**, and his **XYL, Ann**, who are on special assignment assisting me in selecting a few additional QQ advertisers. (Have any favorites?)

Thanks again go to my daughter, **Kimberly**. She has wiggled a kazillion pixels around creating a cover design that gets us in just the right mood for Dick's Cover Article. Like all the staff and our many contributors—she makes time and volunteers her talent towards making the QQ magic happen!

As a personal note, **NM4T** will make it to Dayton and **FDIM** this year. Past attempts have been thwarted by work related conflicts. I look forward to sharing tales and ideas with all you fellow Extreme Amateur Radio fanatics. (Get your travel plans made early.)

Please let the authors know when you find something you value and be sure to provide feedback on this issue's contents for the July Correspondence column.

And...one last comment: **Larry East**, our #1, All-Star Feature Editor, has now been a Ham for 50 years!

Let's all wish Larry 50 more! ●●

### For Advertisement Information:

#### **Brian Murrey (Acting)**

47 Grassy Drive  
New Whiteland, IN 46184  
brian@iquest.net

### For Subscriptions or Renewals:

#### **Mark Milburn—KQ0I**

117 E. Philip St.  
Des Moines, IA 50315-4114  
kq0i@arrl.net

ARCI Application Form on page 61

## QQ Correspondence

**Forwarded by Ron Polityka—WB3AAL:**

I keep hearing and reading on the list about the QRP Quarterly. I am new to QRP so I wonder what exactly it is? I am totally blind so wonder if it is available in any kind of electronic format?

Thanks so much and I look forward to your reply.

72, **Kevin Nathan—K7RX**

Hi--Jim (Stafford),

Just received the January QQ.

What a lovely presentation and content. Congratulations to all.

72/3, **George Dobbs—G3RJV**

Wow, the 40th Anniversary Issue looks Great!!!!

When I opened the envelope, I was in absolute awe of the changes.

Let me take this opportunity to publically thank the entire QQ editorial team for a very well done job.

You know, QQ should be promoted to the homebrew community; there are a ton of good construction articles in it!

73, **Ed Hare—W1RFI**

Hi Craig,

I just got into my January issue and I have to say you knocked my socks off. I just now sat down and checked my membership expiration. Even though I don't expire until July, I went ahead and renewed just to be sure I didn't screw up and forget. I don't want to miss a single one of the Anniversary issues (or the subsequent ones either)....

I read where your daughter helped out. She did a stunning job — it is quite elegant. Warmest Regards, **Wally Linstruth—K7AMI**

I am sure you have been inundated with letters and messages regarding the latest issue of QQ, but let me add my voice to the chorus: well done. I must honestly say, that QQ won't have to go too much further before it rivals QST with respect to professional quality layout and appearance. Of course, the content already—and for some time—exceeds QST.

Now, the most important thing for me is to be sure I re-up in time so I don't miss any issues. I guess I'll copy Mark—KQ6I, to be sure...my pen is poised over the checkbook.

72, **W. H. Phinizy—K6WHP**

4 April 01

What a surprise when the January 2001 QRP Quarterly came through the door. The colour covers are great—this makes a real difference. Not only is QRP Quarterly the BEST QRP MAGAZINE available...it now looks the part. As usual all the contents are a great read. This is one of the few magazines where I read every article published. Please pass on my congratulations to the publications team. Regards, **Brian—GM4XQJ**

Craig:

Having been a member for many, many years I must say this issue of QQ is the best ever. My thanks to all who worked on it.

**ED—AE4EC**

Wow, the 40th Anniversary Issue looks Great!!!!

**FYI on the cover of the January issue:**

**Top Left** = Ron de WB3AAL on the Appalachian Trail above Hamburg, PA. The building in the background is the Leigh Valley Astronomical Society's telescope.

**Top Right** = Ron de WB3AAL on the Appalachian Trail 3 miles east of Route 501 in PA. The picture was taken in October 2000, wx was snow and 28°F.

**Bottom** = Carter de N3AO on the Appalachian Trail near Hawk Mountain Sanctuary in PA.

72 & 73, **Ron Polityka—WB3AAL**

The January 2001 issue looks so good I am afraid to spoil it with finger prints.

What an outstanding publication!

I can hardly wait for time to sit down and read through this magnificent rendering of QRP information. I particularly like the "Table of Contents" in which the "Idea Exchange" has all subjects listed, and in order no less. This one will be hard to follow and all concerned should be proud.

Thanks for such great work and especially for so much personal time and effort.  
72, **George Lee—KR5C**

I was home, sick with the deadly scourge that is running through the Midwest this season. When I opened my mailbox and found the QQ in there it made my day. All I can say is WOW!!!. The Editor has certainly set the bar high with this issue. Full Color Covers. Good Articles (especially the AT articles since I will be there next fall during the Rocket Boys festival), Some good awards articles and

milliwatt articles. It certainly was a joy to read, especially after being cooped up all day feeling sorry for myself. I was so inspired I dragged myself over to the radio and made a few Q's.

**Brian Cieslak—AE9K**

Ken & Staff—Got my copy today WOW!!!!!! Great job guys! How are you going to top this one?

73, **Buck—N8CQA**

My hat is off to our new editor, Craig Behrens--NM4T who is responsible for the new look in QQ. Color, quality printing and a printer who is timely. It sure looks like our printer problems of the past are over. My compliments!

**Mike Branca—W3IRZ**

Is that Cover Great or what? (Both Front and Back!)

72, **G. "Danny" Gingell—K3TKS**

Pardon the bandwidth. But I must publicly commend Norcal and QRP ARCI and all of their fine contributors.

I recently re-subscribed to QRP Quarterly and QRPP after an absence for about a year. I was pleasantly surprised to find a new issue of each in the mailbox today. The Norcal effort is excellent as usual. The illustrations are superb. The Quarterly is incredible. It would make any commercial publishing house proud. The focused content of both will keep me busy reading for some time.

Thanks for all of the hard work!!!

73, **Jeff—WD4ET**

Thanks, gang, for the many kudos we received for the January issue. This (and the \$0.00 salaries) drives the QQ Team on to create the best QRP magazine achievable.

We humbly acknowledge all the little errors last time around and are busy refining our process to assure continued improvement in all future issues.

Please take a little time to provide reader feedback on the articles in this issue for our July issue column. 72, The QQ Staff ●●

*Congratulations to:  
**Petr Doudera—OK1CZU**  
Praha 9, Czech Republic  
Dick Pascoe has given his free 1-year QQ  
subscription for the cover story to you!*

# Base Current

Jim Stafford—QRP ARCI President

w4qo@arrl.net



## The thrill is back!

We continue to get great help in the club. As always, if you want to help, let me know or join the Action Team - see web site. I want to let you know that Dale Holloway,

scribers, but we did run up to over 1700 from around 1500 a year earlier. We appreciate everyone's subscription. If you are getting this, you are not in the group of over 8000 members who no longer renew. All our club workers and many members continue to work to improve the former number and reduce the latter one. Thanks. We put together a little contest for folks who "sponsored" a new member or renewal of a long lost member during the year. Thom Durfee, WI8W, sponsored 8 and so wins one of the MFJ gift certificates (thanks Martin for these!) and we drew the other one at random and it goes to Erwin

3200 foot elevation. It was a nice day and coverage on the lists gave folks notice, albeit short and I think they got a kick out of receiving QRP ARCI #1 from K6JSS/4. If you would like to activate the club call during an event or contest, please contact Mark Milburn, the call sign trustee and reserve it.

K4EQ, has asked to leave the Membership Chair position and in his place is Steve Slavsky, N4EUK, our "old" awards chairman. We want to thank Dale for his work this past year. I know he was a factor in the growth of the club during this period - have you seen the ad in the classified section of World Radio magazine? This is just a small part of Dale's work. Thanks Dale. Steve is jumping into the fray with lots of ideas on how we can keep the momentum during 2001. The Membership Chairman is basically in charge of publicity and promotion. If you need info on the club, Steve can provide it. Simply contact him - addresses for all officers and chair holders appears near the rear of this magazine. Please note that your dues continue to go to Mark Milburn our treasurer, not Steve.

## 2k in 2k contest

Well, it has been a good year for the club indeed. We didn't make it to 2000 paid sub-

---

*It was truly impressive to see a room of youngsters building these little rigs*

---

Beemer, K8EB. Each will receive a certificate for a choice from 10 prizes valued at up to \$100. Congrats to these and all who sponsored folks during 2000. Now that you are in the mood, keep finding new members. We no longer use the "sponsor" term or keep track of it, but you certainly can help us reach 2000 in 2001!

## Club Call

Got a chance to activate the new club call sign on February 10 from the Appalachian Trail at Big Rock Gap in western N.C. Made 44 contacts in a couple hour period from

## FDIM 2001

Probably the most exciting thing as we look toward FDIM2001 is this year's specialty contest - QRPy. It's a contest to design a project that would be of interest to "youth". It doesn't even need to be a transceiver or even a receiver but it could be. Put on your thinking cap. Doesn't have to be complicated but would it interest a 10 year old? Check out the details on the club web site.

## Pixie Day

The club co-sponsored a Pixie building day by Venture crew #73 in the Atlanta area on January 13. There were 18 youth builders of the rigs and many mentors, some from my local club - NoGaQRP. It was truly impressive to see a room of youngsters building these little rigs. Victor Gann, W4VEG, new ARCI member #10668, is one of the able sponsors of this venture crew and is to be commended for such an outstanding event. Still another reason why - **The Thrill is Back!**

See you at Dayton. ●●

QRP ARCI is proud to announce the Four Days in May (FDIM) for 2001, scheduled for May 17, 18, 19 and 20, 2001 during the Dayton Hamvention. For a more detailed explanation of this year's event and a view of the several past FDIM events, please visit the QRP ARCI web site <http://www.qrparci.org/> and click on the FDIM-Dayton link. Last year, nearly 400 QRP enthusiasts participated in the FDIM 2000 event.

FDIM 2001 will have its traditional design and building contests for homebrew and kits. As usual, these two categories are wide open so bring your latest kit, homebrew project, antennas, whatever! Judges will select winners for prizes, a feature article spot in the next QRP Quarterly.

In addition, we offer the following challenge in an attempt to generate interest in radio/physics by our youth. In recent years many of us have lamented the lack of "youth" in our hobby. With the ARRL announcing the "Big Project," QRP ARCI decided to join this effort and tap some of the most creative minds in amateur radio (QRPers). Let's think outside the box and design some projects with kids in mind.

A brainstorming effort by Wayne Burdick, N6KR and Jim Stafford, W4QO (recent Herb S. Brier Instructor of the Year) offer the following guideline to get you started, the "ten-year-old test." In other words, try to create something that someone ten years of age (or older) living in the year 2001 may find fun. QRP ARCI has intentionally left this category wide open. It does not have to be a "ham radio" project (but it can). We want to assist kids to find the fun in learning and building. So bring the projects to FDIM 2001. Let's see if we can generate some excitement! More details are available at:

<http://www.qrparci.org/fdim64.html#contests>.

# Idea Exchange

## Technical Tidbits for the QRPer

Mike Czuhajewski—WA8MCQ

wa8mcq@erols.com

IN THIS EDITION OF THE IDEA EXCHANGE

Joe's Quickie No. 37: A Homebrew Twinlead Connector, Joe Everhart, N2CX

Adding of a Second 8V Regulator to Improve Frequency Stability in the NorCal 40A, Larry East, W1HUE

Modifications for the MS-15 Transceiver, Steve Weber, KD1JV

ALTOIDS Tins in Various Sizes, Dick McIntyre, K4BNI

More on the Upcoming MN9 QRP Kit, Frank Nance, W6MN

Six Volt Gel Cells Charged from 12 Volts, Sam Billingsley, AE4GX

Locating an Open Circuit in Coax, Arthur Edang View Sine Waves with Better Resolution, Mike Czuhajewski, WA8MCQ

On-Line Notes on the SST Transceiver QRP On-Line

### Joe's Quickie No. 37: A Homebrew Twinlead Connector

*A QRP Hall of Fame member and one of the guiding lights of the NJ QRP Club, Joe Everhart, N2CX of Brooklawn, NJ, continues in his unending string of technical quickies with a simple homemade connector for use with twinlead. As usual, he provided his own graphics.*

*I've liked using 300-ohm twinlead for years. Back in the olde days as a novice (WV2MES) my best 40-meter antenna was a folded dipole made entirely of TV twinlead. More recently I've been using it as a tuned feeder with a multiband dipole. It is lossier than open wire line but it is widely available and much easier to handle. And as NNIG has pointed out it makes a great feeder for portable use. No bother with reels or careful coiling to stash it in a backpack — you just shove it in any way you want and it won't tangle! And it comes in several grades from inexpensive Radio Shack or hardware mega-store variety to foam filled types for low loss TV use and even some low loss transmitting grades.*

However its worst feature is that it can be kinda fragile. The insulating web between the conductors protects it between the antenna and rig, but when you strip the insulation off to connect it, you have to treat the conductors carefully. At the antenna end you can secure them pretty well but the rig end

can be awkward, particularly if you frequently connect and disconnect the leads from a tuner. Ideally you'd like to have a connector that protects the leads from damage and makes them easier to connect than bare wires. A method to deal with both ends is described in recent articles (Ref 1,2.) This Quickie shows the rig/tuner end connector.

The RF connection to most rigs these days is via 50-ohm coaxial cable. So when you use a skywire fed with 300-ohm twinlead you have to use a so-called tuner to match 50 ohms to whatever impedance is presented by the feedline. Several that have been used in the N2CX shack (commercial and homebrew) use 5-way binding posts for their balanced line output and these are spaced to accept a so-called GR plug. Used widely in older test equipment, this plug has two posts compatible with a pair of banana jacks or 5-way binding posts spaced about .72 inches apart. To take advantage of this, the Quickie feedline connector uses two stiff leads spaced about 3/4 inch apart to mate with the binding posts. While the ideal spacing is .72 inches, 3/4 inches is "close enough for government work."

**Figure-1** is a photo of the connector mated with a homebrew tuner while **Figure 2** shows the backside. (Yes, I know, they are different samples, but the idea's the same.) The connector is simply a piece of glass-epoxy printed circuit board with two copper pads at one end to which a couple of stiff leads are soldered. The twinlead is fed through two holes to secure it and each lead is then soldered onto one of the copper pads. The friction of running the leads through the two holes is enough to hold the line firmly so that

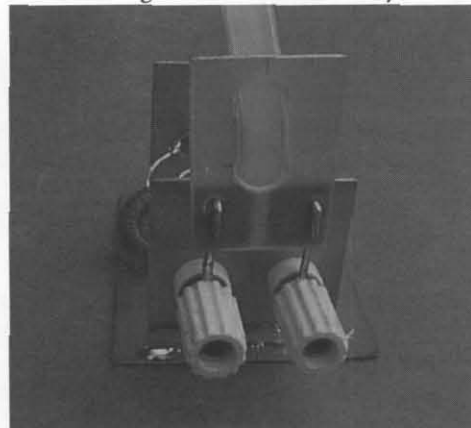

**Fig. 1—Front side of twinlead connector, mated to a tuner.**  
*The QRP Quarterly*

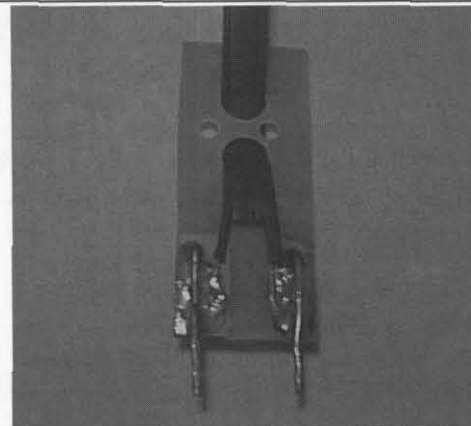

**Fig. 2—Rear side of twinlead connector. This is a different one than in Fig. 1, but the idea is the same.**

the leads are not put under any stress. Connection and removal from the tuner binding posts is easy to do repeatedly as needed without wear and tear on the twinlead.

Connectors for two types of twinlead are described below. Both are suitable for homebrewing without requiring any expensive oddball components or out-of-the-ordinary construction methods. The only materials needed are the twinlead, some copper clad glass-epoxy printed circuit board and a 6 inch or so length of 14-18 Ga. solid copper wire. The same techniques can be used for any other type of balanced feedline you might care to use.

**Figures 3 and 4** show dimensions for common receiving type twinlead and lower loss foam type 300-ohm feeder that I have found locally. Their different widths and stiffness require tailoring connector hole size and spacing to hold them securely.

Construction is simple. First cut the printed circuit material to size. Overall dimensions are not too critical so long as the board is wide enough give the tuner-end wires enough spacing and locate the twinlead holes

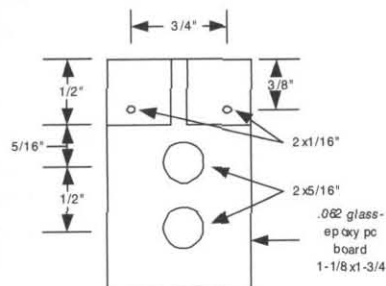

**Fig. 3—Connector for small twinlead.**

www.qrpq.org/



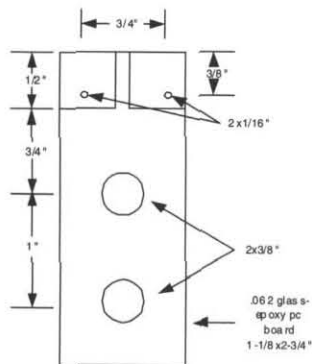

Fig. 4—Connector for larger twinlead.

appropriately to secure the feeder.

Next you need to remove the copper cladding from the pc board stock. If it's double-sided remove the copper completely from one side and selectively from the other as will be described shortly.

Removing the copper foil can be learned easily with a little practice. It's best to try it on some scrap material before tackling the connector so that you can gain the needed skill on disposable material. Using a sharp utility or hobby knife, peel up the copper at one corner. Then peel it off with small needle nose pliers. You probably won't get it completely off in one try, so just use the knife to lift up another corner and repeat as needed.

As you can see by the figures, you need to leave two copper pads on one side of the connector. This process is done as follows:

1. Deeply score the copper foil about 1/2 inch from one end of the board. The copper at this end will be the final pads.
2. Carefully peel the copper off the board up to the score marks. If you have made the scoring deep enough the peeling will stop at that line.
3. Score two lines about 1/6 to 1/8 inch apart along the center of the 1/2 inch remaining copper to isolate them from each other.
4. Carefully remove the copper between the two pads. The end result should look like the photos.

Now you can mark the holes and drill them as indicated in **Figure 3 or 4**.

Prepare two 14 to 18 gauge solid copper wires about 2 inches long and tin them. Put one through each hole on the copper side of the connector and bend over about 1/4 inch on the back to hole it in place. Solder each wire to its copper pad.

To install the twinlead, first strip back the plastic webbing on the end for about an inch and strip back the insulation leaving about 1/4 inch of bare copper lead showing. Run this end through the large hole on the

copper side of the board farthest from the pads. Snake it under the board then up through the second hole. Solder the leads, one to each pad. Finally, trim the solid copper wire leaving about an inch of wire past the connector.

The twinlead should be securely held in place but if you think it needs additional support you can drill small holes either side of the twinlead midway between the two large holes and secure it with a nylon tie. I did this on the first connector I built but found it unnecessary.

**Ref 1**—"80 Meter Alchemy" QRP Homebrewer, Spring 2001

**Ref 2**—"The NJQRP Squirt" QST, April 2001

—DE N2CX

### Adding of a Second 8V Regulator to Improve Frequency Stability in the NorCal 40A

*Over the years, QRP Quarterly associate editor Larry East, W1HUE of Idaho Falls, ID has had a long string of modifications and improvements to various QRP rigs. Here's his latest.*

I recently "upgraded" my NorCal 40A by modifying it for 5W output. I did that by replacing the stock PA with an MRF237 and RFC1 with a 4:1 matching transformer (six bifilar turns on an FT37-43 core) and FB43-101 decoupling bead, all mounted under the PC board. I now get a maximum output of 6W—very clean and no signs of instability.

I decided to make some frequency stability tests to see if the added heat from the new PA resulted in any VFO drift. I discovered that the VFO frequency drifted upward 30-50 Hz when the rig was being keyed, then returned to its "unkeyed" value after a minute or so. Yes, I know—this amount of drift is rather insignificant, but I'd previously reduced the VFO warm-up drift to less than 100Hz, so this small drift was definitely noticeable. (OK, so some of us have too much time on our hands...)

I assumed that the "key down" drift was due to heat from the PA, but I happened to turn the output power down to zero and the drift was still there. Looking at the schematic, I noted that the load on the 78L08 voltage regulator (U5) would increase slightly during transmit due to Q4 being turned on and supplying "8V TX" to U4 and Q5. U5 also supplies the LM386N audio amp, which can also present a varying load depending on audio output level.

Could it be that U5's output is changing due to internal heating under heavier load conditions? To test this possibility, I measured the output of U5 using a Fluke 853A differential voltmeter (a very useful instrument—got it a few years ago at a hamfest for \$30) under key-up and key-down conditions.

I discovered that its output gradually drifted up 6-7mV when the key was held down, eventually stabilizing after about 30 seconds or so. Monitoring the VFO frequency (with a frequency counter) at the same time showed a corresponding upward drift of 60-70Hz. So ... the culprit is U5! The "problem" had been there all along, but I just hadn't noticed it.

I first considered replacing U5 with a "premium" regulator IC—an LM78L08ACZ for example. But I decided that a better solution would be to add a second regulator just for the VFO and associated circuitry— independent of "8V TX" and the audio amp. I had just obtained a couple of NJM2903L08 low-dropout regulators (from Mouser Electronics) to test, and decided to use one of those—not because of the low-dropout feature, but because the line and load regulation specs are even better than for an LM78L08ACZ.

A little testing on the bench also showed that the temperature sensitivity was much less than the 78L08 used in the 40A (which may or may not be representative of such devices).

I added the '2903L08 below the board—essentially under the VFO components—and cut the "jumper trace" on top of the board between RFC2 and R5 that feeds +8V to Q8, U1, U2 and U6. +8V to these components will now be supplied by the new regulator. To get +12V to the new regulator, I ran a wire from the power switch at rear of the board.

Since low drop-out regulators require at least 10iF on their output to insure stability, I tacked a 10iF tantalum cap across C54 on the bottom of the board. (I could have replaced C54 with a 10iF cap, but decided that adding one under the board was easier).

Problem solved—there is now no measurable frequency change between key-up and key-down! Immunity to supply voltage fluctuations is also better; a change from 12.0V to 14.0V causes a shift in VFO frequency of only 36 Hz compared to about 70 Hz previously. The downside is an additional 5mA or so in receiver current consumption—but I can live with that.

In retrospect, the frequency shift probably could have been significantly reduced—

and perhaps eliminated – by simply replacing the stock 78L08 with the NJM2903L08.

Moral of the story: It isn't just capacitors and inductors that you have to worry about when chasing VFO drift problems!

—DE W1HUE, w1hue@arrl.net)

### Modifications for the MS-15 Transceiver

Steve “Melt Solder” Weber, KD1JV is one of the regular technical wizards on QRP-L and has produced several kits in small quantities over the years. One that he did recently was called the MS-15, a superhet transceiver for 15 meters, and he later posted some supplemental information on it to QRP-L. Only a small number were produced, probably well under a hundred, and it will probably not be made available again; and since it was proposed and then offered on QRP-L, just about everyone who ordered one has probably seen the online “errata sheets”.

*However, this information is still worth repeating here for two reasons. First, some of the basic principles can be also applied to other designs. And the second reason is the same one that caused me to reprint info on the NJQRP club's SOP receiver kit even though everyone who bought one was sent the updates: there's a good chance that not all of these kits will be built right away and may well be resold to others in unbuilt form, and the updates not be included. There's an equally good chance that the new owners will have never seen this info on QRP-L. When they experience difficulty and ask for help, there's a chance that someone will remember seeing it here and be able to help. (Regulars on QRP-L know that kits of various types end up being resold unbuilt; in fact, I have both the MS-15 and SOP RX and will probably end up selling them unbuilt years from now!)*

Problem: In-band spurs or impure transmitted note, while operating near the top of the tuning range. Cause: Noise on the output of the op amp supplying voltage to the tuning diode. Cure: Remove C46, then it solder across R2, on the bottom of the board. This bypasses the op amp feedback resistor, instead of the input.

Problem: little or no output power. Cause: There is apparently some variation in the amount of coupling in the IF transformers; some are significantly less than others. Cure: Contact me (kd1jv@moose.ncia.net) for a replacement for T4; I will select an optimum one to use there. [WA8MCQ note—this offer may well not be available indefinitely and you may be on your own here, but at least you'll know where to start troubleshooting. Unfortu-

nately, variations from piece to piece of the same part are not unknown in the electronics world.]

Much to my dismay, a drift problem has been noted when transmitting with the MS-15. I have discovered the main cause of this drift to be the D2 diode, which is in series with the bottom leg of the tuning pot. This diode was supposed to correct for temperature drift, but in fact makes it worse. The fix is simple—remove D2 and replace it with a fixed resistor you select to limit the tuning to the desired minimum frequency, 21.00 or 21.025 MHz perhaps.

Moving the tuning diode (D1) to the bottom of the board also seems to help. These mods greatly reduce the amount of drift during prolonged transmit. If you have a small (20 pF) air variable cap and vernier dial, you can replace the diode tuning with the capacitor and eliminate all drift. Simply lift the end of L2 which goes to the tuning diode and jumper over to the air variable cap rotor. Ground the stator.

—DE KD1JV

### **ALTOIDS Tins in Various Sizes**

Many homebrewers, especially those who are regulars on QRP-L, the Internet QRP mail reflector, are well aware of the popularity of building things into Altoids tins. Back in the old days, we used to use Sucrets tins. Sadly that product long since went over to plastic, but the appearance in this country of the British Altoids mint several years ago sparked quite a frenzy of building. For the benefit of those who are somehow unaware of the product, which bills itself as “the original, celebrated curiously strong” mint, they come in a small hinged metal box approximately 2.3 X 3.7 X 0.8 inches and are found among the candy bars and gum everywhere. Although not seen as often, there are other sizes as well. Dick McIntyre, K4BNI of Basye, VA writes—

You may wish to inform all the Altoids aficionados that there is a smaller version of the now popular can. The size of the smaller one is 1 1/2” wide, 2 1/2” long and 5/8” high. That size should challenge all the QRP talents. There is also a larger one measuring 4” wide, 7 3/4” long and 1” high. Both are metal.

—DE K4BNI

### **More on the Upcoming MN9 QRP Kit**

Frank Nance, W6MN of Reno, Nev, has been developing a QRP transceiver kit called the MN9 for a while. He had two articles

about it in the QRP Quarterly, in the April 1999 and April 2000 issues. He still hasn't gone into production, but is making progress; here's his latest update.

What follows is a long overdue input to those QRP Quarterly readers who have shown enough interest in the proposed MN9 QRP HF Transceiver kit to write. Literally hundreds of email inputs have been received, and many favorable exchanges followed, since the first article. In Part II in the April 2000 issue, I indicated that the rig was very close to the production phase. Obviously, the anticipated date has gone by the wayside. Health problems began to develop early in 2000 and progressively grew worse but, thank God, are now leveling off.

The passing of time has allowed for reflections, not only on the design of this kit but also allowed room to do those neat thinking sessions along the line of, “what if this or that was included”. The outcome is very exciting in that I have reevaluated one of my prior patent applications and think that there is an economical way to do a precise job of direct digital synthesis (DDS) and at the same time greatly reduce phase noise.

Once health allows, my work schedule will be split between MN9 kit work and the exploration of the DDS. Circuits using this resurrected patent application will also allow for easy computer interaction directly with the kit. My goal will be to evaluate whether this new feature can be added for less than \$100, including software.

My first work in this direction has been to experiment with math operations and various windows types of display. The math work covers software solutions to stages of DDS in the patent application concepts. The windows display will be potentially used for interactive operation of the kit. I am using Java at this time. To a C or C++ programmer Java might be too slow, but the added time is not critical to this application and there is merit to using Java, even though slower, as it does its thing in two steps, *interpret and compile*. Kit users would have free access to the Java Development Kit, keeping up-front software cost to a minimum.

The second delay and setback is that Motorola announced that the MC1350 is now out of production. Three stages in the MN9 kit used it; this means that they need to be redesigned and new PCs made, a task which I eagerly look forward to as soon as health allows. Smaller companies using this IC have already snagged all remaining supply.

One potential idea to replace the MC1350 is to use a low-noise dual discrete transistor RF amplifier with some regeneration. It remains to be seen if this is a useful idea, especially as an AGC range even beginning to approach that of the MC1350 is to be designed with limited parts count.

A friend is also going to try this regeneration idea in a 3 or 4 stage front end (with tracking between stages) for potential use in direct conversion receivers. The idea is to use these regenerative stages to reduce bandwidth of signals allowed to arrive at the direct converter. If this idea is practical in the QRP arena, I will prepare an article for the QRP Quarterly.

#### Vackar LC oscillator notes:

The VFO uses a Motorola MV104 varactor for tuning. With no corrective feedback the VFO drift would be quite unacceptable in ham applications. Two loops are included to compensate for (1) the temperature coefficient (TC) of the MV104 at a reference temperature of 25 degrees C (nominally 280 parts per million), and (2) to compensate for the fact that the TC changes as bias, and thus tuning, is changed. This second condition is serious enough to warrant one loop to compensate for the TC at a mid band reference setting, and the other that accounts for change in MV104 TC with change in bias and thus drift at frequencies other than at a mid-band setting.

In the previous articles, two compensating loops were described to take care of these problems in the TC variations. However, in doing extensive parts tolerance effect tests using a quantity of 30 MV104s, several minor problems began to surface as the rig was subjected to temperature and bias extremes. I should have anticipated this originally because the published TC is nominally 280 parts per million (PPM) with a maximum of 400 PPM, which is quite a range in part tolerances in terms of temperature coefficient.

In the first version (April 1999) the outputs of the two compensating loops were fed independently to separate inputs to an op amp DC adder, where the correcting DC quantities were algebraically summed with the linear tuning pot DC output.

This had a slight design flaw, in the idea that summing the two loops independently disallowed for the effects of part tolerances when tuning to the two extremes. I have corrected this and run tests with good results. I soon realized that I should have placed the two loops in series. The first loop consists of

the original circuit where a sample of the tuning DC was inverted and scaled so that as tuning bias is changed, an opposite, scaled-down DC compensating voltage is available at the output of this first stage.

Then, by feeding the output of this first loop to the input of the second, in place of a fixed thermistor DC voltage, a much more accurate compensation resulted throughout the whole temperature and tuning ranges.

The second loop was revised as follows: The original circuit, consisting of a Semitec thermistor and scaling series/parallel loading resistors, was placed in a bridge circuit with an op amp as a temperature error detector. In place of a voltage that is normally applied across the bridge, the properly scaled DC output of the first loop is applied.

A third, minor problem has also been corrected, which has to do with MV104 TC part tolerances. The original MN9 tuning pot wiper output was very linear. However, the TC vs DC voltage curve is not quite linear and the curve is slightly different from one MV104 to the next. To correct for this, the original pot wiper with an adjustable loading resistive circuit is used to generate a direct current that fits the desire curve for the individual MV104 used.

Thus, the output of the first loop more closely fits the desired curve. In alignment, at the center of the VFOs tuning, the second loop is set to compensate for TC at that setting, using a 10K resistor in place of the thermistor. Then the scaling of the first loop, when adjusted correctly, makes compensation in the output of the second loop more accurately reflect changes in TC as the MV104s DC bias is changed.

Another factor showed up in recent bench tests. Very small disturbances in the frequency of the VFO were observed. While the two-loop frequency compensation in my bench lab model kept drift to much less than +/- 1 Hz at 27 MHz, minor FMing variations of about 1 to 3 Hz in the 27 MHz oscillator's output frequency were observed. In listening for the purity of the VFO, using my TS870 and a spectrum plot from PSK31 mode on my PC, these small disturbances were observed, audibly and visually, sometimes to have gradual, sometimes sudden, FMing of about 1 to 3 Hz.

These disturbances might be minor to some, but to my ear, the variations were not pure enough for what we used to give in an RST report where a T = 9X meant a tone as pure as a crystal oscillator output.

The disturbances were found to be

caused by microvolts of DC variation in the op amp outputs. I let this one slip thru the crack in the earlier design. The cause center in the idea that an inexpensive op amp like the LM324 is limited in accuracy to about 5 decimal places. Minor variations of microvolts in the LM324's output in everyday AF and DC usage are insignificant. However, when the output of an op amp is used as DC bias applied to the MV104, these microvolt shifts in DC equate to the 1 to 3 Hz VFO FMing variations. In the LM324 and all other op amps in this class, small offsets are well known and most good op amp texts show how to go to op amps that can handle corrections.

The open loop gain of an LM324 is typically 200,000. With a center tuning voltage of about 3 volts coming out of the LM324 that feeds DC to the varactor, this equates to a minimum expected output tolerance of  $3 / 200,000 = +/- 15 \text{ mV}$ . The need is for less than a microvolt of such random internal offsets.

The solution is a better op amp, one with the ability to null out these effects. There are quite a number of these correctable devices available. One with an economical version is being sought as this update is being written. If you are building a VFO using these compensation loops, and if you know about and have correctable op amps on hand, they will correct for these minor disturbances.

For those that want to use these refinements, please send me an email or snail mail at the address below and I will be glad to share the circuit details.

With all negative situations covered above, I still think that there is much merit to continuing the MN9 kit development because positive results are around the corner of my bench work. For those who want to try the VFO refinement, please contact me at my email address: frank@w6mn.reno.nv.us or write to Frank Nance, 21 Coventry Way, Reno, NV, 89506-1999.

—DE W6MN

#### Six Volt Gel Cells Charged from 12 Volts

This battery idea comes from North Georgia QRP Club member Sam Billingsley, AE4GX of Atlanta, by way of QRP-L.

My Olympus Digital Camera eats a set of 4 alkaline AA cells quickly so I wanted to have something to last longer. I worked up a camera shoe adapter to hold a single gel cell and plugged it into the camera coax power connector. I thought about using a 12V gel cell with a 6V regulator but the heat gener-

ated by the LM317T was too much to handle in a small size enclosure. (I actually built it up.) So I rigged up two 6V cells with a DPDT switch (figure 5). I run them in parallel for camera use (6v) and switch them in series for charging with my normal 12V (13.8V) charger.

The camera looks like it's got a big battery pack below it but the longevity problem is solved. I now have a 6V 2 Amp-Hr battery pack that's rechargeable from my standard 12V chargers for \$5. Its not quite QRP but the concept could be used for a 6V QRP rig or 6V emergency light (lantern battery alternative) source.

—DE AE4GX

### Locating an Open Circuit in Coax

*Electronic Design* is a popular trade journal that has a regular section called **Ideas for Design**. It presents circuits and ideas sent in by readers, and the January 22, 2001 issue had one of interest to QRPers. It was sent by **Arthur Edang** of Don Bosco Technical College in Mandaluyong City, Philippines.

He starts by telling how opens, shorts and mismatches along a length of coaxial cable can be precisely located by using a time domain reflectometer. It's a device that sends a pulse down the cable and observes the returning echo. The time between the two can be directly converted to distance. The ham and hobbyist press have had a few articles over the years on doing this at home, consisting of little more than a simple pulse generator used in conjunction with an oscilloscope.

Unfortunately an oscilloscope is mandatory, and not everyone has one. But if all you need to do is detect open circuits, you can use his circuit (shown in figure 6). It uses the ubiquitous 555 timer chip operating in the astable mode. The distributed capacitance of the coaxial cable is used to replace the frequency determining capacitor in the circuit.

As the cable length gets longer the capacitance increases and the oscillator frequency drops; shorten it and the frequency goes up. He gives the formula that determines the frequency of a 555 timer chip:

$$F = \frac{1.443}{(RA + 2RB) C}$$

with F in Hz, resistors in ohms and C in farads.

A given length of cable has a certain capacitance (X picofarads per foot times Y feet) and gives a frequency of a particular value when connected to this circuit. If it develops

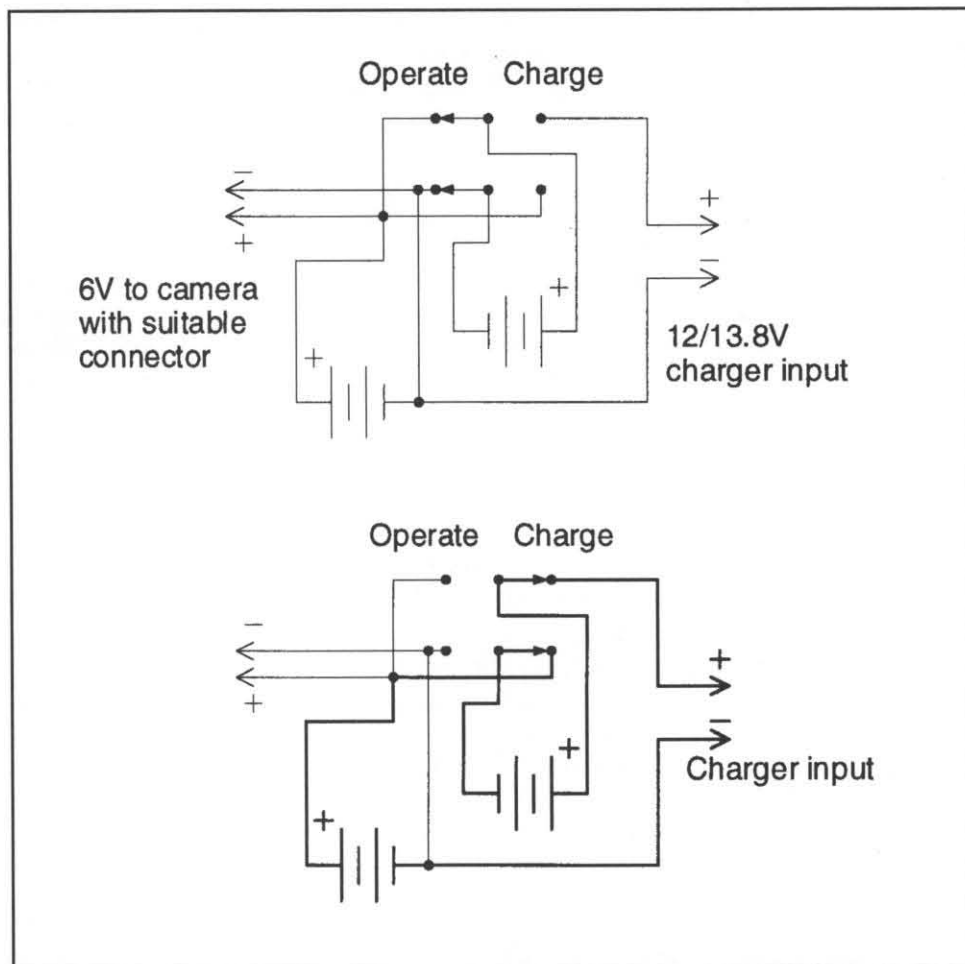

Fig. 5—Top, cells with switch in Operate position, putting both in parallel to supply 6 volts to device. Bottom, switch in Charge position, putting cells in series for charging from a 12 or 13.6 volt charger. Heavy lines show the charging circuit path.

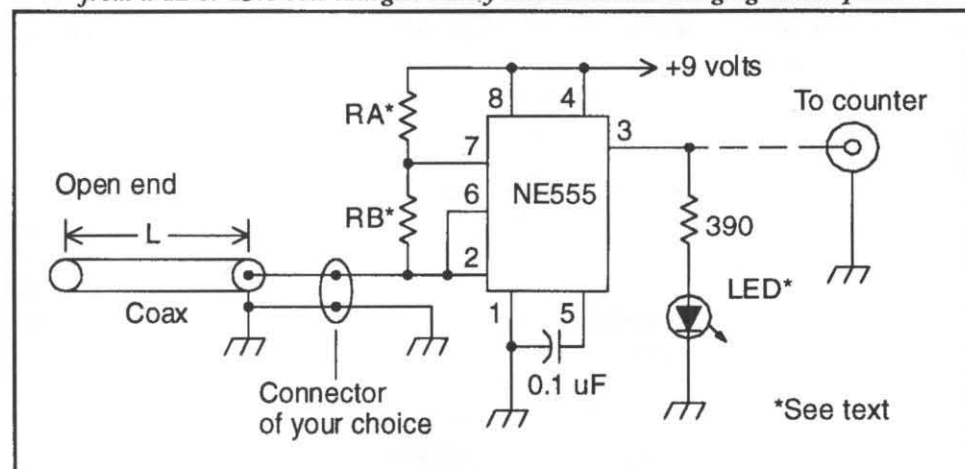

Fig. 6—Coaxial cable length tester. Capacitance of the cable determines the frequency of the oscillator, which can be measured and correlated to distance. See text for discussion of the LED and the values of RA and RB. Original values are 66 and 35 megohms respectively, but I'd use 68K and 33K (or 36K) myself.

an open circuit along it's length it's effectively a shorter piece of cable with a lower capacitance.

Connect it to the circuit again and observe the new frequency; you can then calculate the new effective length, which is the distance to the open circuit. The original ref-

erence length is L1 and the frequency it generates is F1. Observe the new frequency, F2, and solve the equation to determine the new length, L2; note that the relationship is inverse.

$$L2/L1 = F1/F2.$$

His circuit uses an LED and some very large resistors at RA and RB to give a slow blinking that can be timed. He gives an example of 45 meters of RG-58/U giving a flash of 1.67 Hz, and an open circuit introduced at a point 25 meters from the circuit giving a new frequency of 3 Hz. For other lengths (or types) of cable, he says that RA and RB may need to be modified to make visual checking possible. He also states that the output of the 555 can be sent to a frequency counter for a more precise reading.

Timing a flashing LED doesn't sound terribly precise, although it isn't as bad as it might seem. Measuring the interval between two flashes is hard to do, but you can get better results by counting a large number of flashes, perhaps 10 or 20, then dividing to get the average. A frequency counter is even more precise, but there can be times when one is not available.

If I were to build the unit, I'd scale resistors RA and RB downward by a factor of 1000 to raise the frequency into the audio range, and use only a counter. Also, it may be easier to find resistors in the tens of K than in the megohm region.

Here's a sample. Assume a cable having 100 pF capacitance per meter, and his values of RA = 66M and RB = 35M. Forty five meters gives 4500 pF, and plugging that into the formula gives a frequency of 2.36 Hz. An open circuit developing at the 25 meter point would raise that to 4.24 Hz. (Try timing a large number of flashes at that frequency—counting them would not be easy! I'd stick with the frequency counter.)

Dividing the two resistors by 1000 and using standard values of 68K and 33K gives a frequency of 2393 Hz for that 45 meters (4500 pF). Twenty five meters would give 4307 Hz. Knowing that L1 is 45 meters, F1 is 2393 and F2 is 4307, we rearrange the formula a bit to get  $L2 = F1L1/F2$ , plug numbers in and come up with 25 meters for the new length.

You can also use the device to determine the length of an unknown piece of cable if you know the type. (For instance, you might have a reel of cable of unknown length and want to know if it's long enough for what you need, or want to make a good estimate of its value if you're buying or selling.)

Connect the unknown cable to the oscillator and record the frequency it produces. As an example, let's say it's 3076 Hz. Next, calibrate the oscillator by connecting a capacitor of precisely known value; a good value might be 1000 pF. Note the frequency that

it produces. If all component values are exactly on the money, it would give 10,769 Hz.

Divide the frequency produced by the cable by that produced by the known capacitance. This ratio will tell you the ratio between the capacitance of the cable and the capacitor of known value. Remember that the relation is inverse; a higher capacitance produces a lower frequency and vice versa. If the frequency of the unknown is 1/3 the frequency produced by the known capacitor, the unknown capacitance is 3 times as great. Divide 3076 by 10769, then invert the results (using the 1/X key on your calculator if it has one) and the result is 3.5001. Multiply the 1000 pF reference capacitor by that number to get the capacitance of the unknown cable; in this case we get 3500 pF.

Now we know the capacitance of the unknown length. Look up the capacitance per foot for that type of cable, which can be found in the ARRL handbook and other references; a typical value would be about 29 pF per foot. Divide the capacitance of the unknown length by the capacitance per foot, and you now know the length. ( $3500/29 = 120.7$  feet.)

When the magazine came out, Dan Tayloe, N7VE, commented about it on QRP-L. He pointed out that one could also use a capacitance meter to measure the cable. The same principles to determine length still apply.

### View Sine Waves with Better Resolution

Many QRPers use oscilloscopes to view sine waves for various reasons, often measuring their amplitude. Although most modern, expensive scopes will give an automatic readout of amplitude and time intervals in numbers on the display, less expensive or older ones only have the display graticule to use for this purpose. (That's the grid pattern on the display, with the central X and Y axis lines marked off in small segments, usually 5 per division; see Figure-7.) Although this visual measurement has less resolution than the digital readouts on some scopes, you can maximize the resolution with this simple method, which applies in some cases. Although most people using scopes are probably aware of this, beginners might not be.

An old rule of using an analog multimeter is to adjust the range such that the needle is as far as possible up the scale to get best accuracy. The same principle applies here; we want the waveform to be as large as possible. As with the meter, you can only read the scope trace visually to a certain degree. A typical

scope has 8 vertical divisions, with each marked into 5 subdivisions. You can read the size of a trace to the nearest subdivision, or even half of that, but it's hard to be much more accurate.

Assume the scope is set for 1 volt per division. With a waveform occupying 1.4 divisions, that one half subdivision of uncertainty, or 0.1 division, is about 7% of the total reading. Increase the sensitivity to 0.2 volts per division, and now the waveform will occupy 7 divisions. The visual accuracy still isn't much better than 0.1 division, but now it represents only about 1.5% of the total reading. Bingo—higher accuracy.

Figure-7 shows a sine wave being displayed with the scope set for 5 volts per vertical division. Since the signal occupies about 4 divisions (out of a total of 8 divisions on the display), the peak-to-peak voltage is about 20. But is that 4.0 divisions or 3.8? It's a bit hard to see, but it looks like the signal isn't quite 4 full divisions.

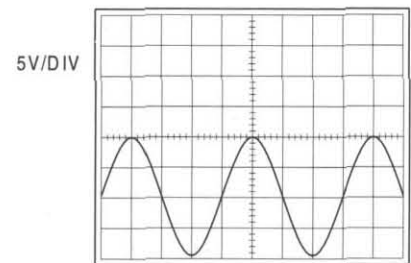
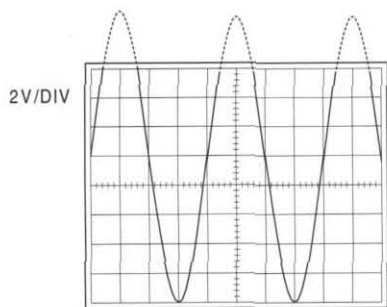

Fig. 7—A signal of approx. 20 volts peak to peak, at 5 volts per division.

To get a better look, we crank the scope up to 2 volts per division. The problem is that the signal goes off the screen (Figure-8). If the signal occupied half of the screen or less and we switched to a more sensitive setting that was a multiple of 2 (such as going from 2 volts/division to 1) it would still fit on the display. However, going from 5 V/div to 2 is a ratio of 2.5, so signals that were close to half of the screen will become too large.

But we're dealing with what appears to be a pure, undistorted sine wave, and those are symmetrical about the horizontal axis. The top and bottom halves are identical, and if we can display exactly half of it we can measure it more easily by cranking up the sensitivity and still keeping it on the screen. What we'd see then would be the peak voltage, which we could double to get peak-to-peak. We need to find out exactly where the midpoint of the signal is and put that on the bottom line of the display. And since we're dealing with a nice, clean sine wave it's quite easy.

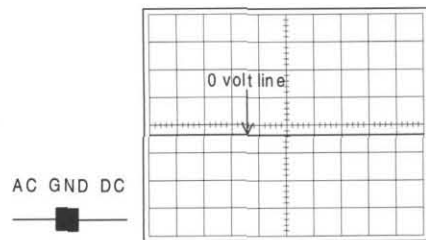

**Fig. 8**—If the display is reset to 2 volts per division for better resolution, part of the signal will be off the screen.

Switch the vertical input selector from whatever it was on to ground (GND), or simply disconnect the probe from the front of the scope. As shown in **Figure-9**, the display line will now indicate the ground or 0 volt position. This may or may not be in the middle of the display; in this case it's slightly off the center. Next, using the vertical position control (**Figure-10**), move the trace until it's on the bottom line of the display.

Move the input selector to AC (**Figure-11**). This lets us see half of the signal rising above the ground reference line and half below it, regardless of any DC component the signal might have. (If we moved the selector to DC coupling, the sine wave would not necessarily be centered on the ground reference but might be offset from it in either a positive or negative direction.) **Figure-11** shows the same display that resulted from the 5 volts per division setting in **Figure-7**, but now the upper half is above the bottom line and the lower half is off-screen, below the line. The peak value can be read from the vertical scale, and doubled to get peak-to-peak.

But the signal is still relatively small, and if we make it larger on the screen we can get a more accurate reading. In **Figure-12** we crank the sensitivity up to 2 volts per division and take our final reading. Now we can see that the peak value of the signal is 4 and 4/5 division, or 4.8. At two volts per division that's 9.6 volts peak, or 19.2 volts peak-



**Fig. 9**—Move the input selector to ground (or simply disconnect the probe from the scope). The 0 volt line will appear somewhere on the display.

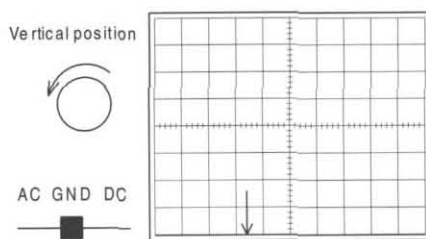
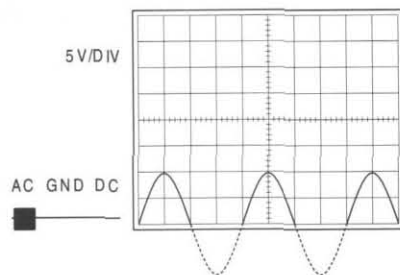

**Fig. 10**—Adjust the vertical position knob to put the trace on the bottom line.

to-peak.

On a scope display like this with each division divided into 5 tiny segments, or 2 tenths of a division, about the closest you can call something is to within one tenth of a division. At 5 volts per division, as in **Figure 11**, that works out to 0.5 volts. Now that we're down to 2 volts per division, we can estimate the value to within 0.2 volts, a decided improvement in accuracy.

(A possible topic for a future column would be a discussion about the vertical input frequency response of the scope. Just because you have a signal of, say, 6 divisions



**Fig. 11**—Switch the coupling to AC. Half of the signal will be above the 0 reference line, half below.

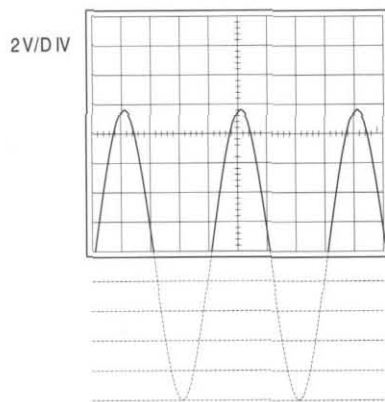

**Fig. 12**—Change the sensitivity to 2 volts per division. The peak voltage can be read out from the graticle with better resolution than in figure xx. Double the value to get peak-to-peak voltage.

and the input is set for 1 volt per division doesn't necessarily mean the signal is 6 volts. It could actually be larger than indicated, since response falls off as frequency increases.)

*The QRP Quarterly*

## On-Line Notes on the SST Transceiver

The SST (Simple Superhet Transceiver) was designed a few years ago by QRP Hall of Fame member Wayne Burdick, N6KR, and detailed in QRPp, journal of the Northern California QRP Club. It later became a commercially available product from Wilderness Radio, run by Bob Dyer, KD6VIO (QRP Bob). It generated a lot of discussion on QRP-L, including observations, tests, modifications, improvements, etc. **Jim Larsen, AL7FS** collected all of the postings (currently 140) and put them on his website:

[http://www.qsl.net/al7fs/SST\\_MOD.htm](http://www.qsl.net/al7fs/SST_MOD.htm)

Although it does not contain the latest version and has somewhat fewer of the postings (just the first 95), it can also be found at: <http://www.g3ycc.karoo.net/sst1.html>

## QRP On-Line

QRP-L, which I call the "QRP Daily," is the online QRP discussion forum started in 1993 by Chuck Adams, K7QO. It continues to run several dozen postings per day on a variety of topics related to QRP. QRP-F is an alternative QRP forum started in October 1999 to take some of the load off QRP-L. The forum, QRP-F, requires a web browser such as Internet Explorer or Netscape, while QRP-L is a mail reflector and only requires an e-mail account. To check out either one, just go to the QRP ARCI home page at [www.qrparci.org](http://www.qrparci.org)

From the opening page, click on the spot indicated to enter the web site. For now, resist the temptation to just click on the QRP-F button on the side on that initial page. What follows gives you a bit more flexibility. After entering the web site you'll see a few rows of clickable items at the top. You can click on both QRP-L and QRP-F there.

QRP-L is an independent entity, separate from the QRP ARCI, although the club web page gives a convenient entry point. If you prefer to go to the opening page directly, point your browser to the following URL. (That's a lower case letter "L" at the end, not a number 1.) ●●



FYBQ--Ron Polityka--WB3AAL

[www.qrparci.org](http://www.qrparci.org)

# The CSS Receiver

Larry Stambaugh—WB0RMT

lstamba@netins.net

*This short article originally appeared in the Summer 2000 Newsletter of the Iowa QRP Club (John Burnley, NU0V, editor; email: burnleyia@home.com). We thought some of our readers would be interested in an easy to build yet good performing receiver, so we asked Larry and John for permission to reprint the article, and they graciously consented. —W1HUE*

Building your own rig from scratch is the heart and soul of the good old days of ham radio. When the Iowa QRP Club needed a project, I volunteered to put together something that could be the basis of a homebuilt station: the receiver. To be good for a group doing its first project, simplicity was a must. Good performance, low power consumption, and readily available parts were also important. The name CSS was coined because the first prototype was built in an Altoids® Tin; it stands for "Curiously Strong Superhet". To be simple, the receiver had to have the minimum number of parts, but to have good performance a superhet was deemed mandatory. AGC was a feature that required more parts

so it was left out. A 10mm green slug 10.7 MHz IF transformer was selected for the input bandpass filter because of its size effectiveness and availability. The popular NE602/NE612 was used for the mixer and product detector because of low parts count as well as low cost. To get some immunity from overload, all gain control is done at RF ahead of the input bandpass filter. To get the highest AF amplifier gain for the least overhead, an LM386 was selected. If used correctly the high frequency noise can be lowered to an acceptable level and still have lots of audio.

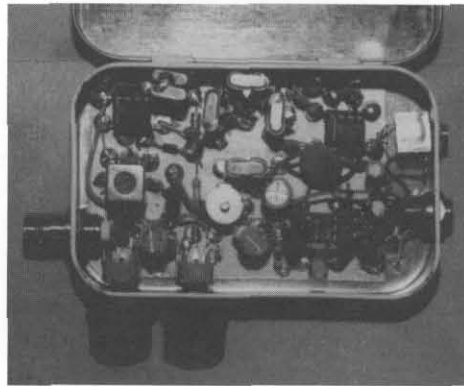

An IF frequency of 4.000 MHz was selected for good three-pole filter performance and so that readily available crystals could be used in the filter.

A VXO was selected to simplify building and to lower parts count. The VXO crystal frequency of 11.059 is readily available and if two crystals are paralleled in the right circuit you can tune at least  $\pm 5$  kHz from 7.040 MHz.

Muting is incorporated and off-the-air sidetone is available so that a transmitter can be added later. Some VXO signal tapped off with a small value capacitor can be fed into another NE602 with a 4.000 MHz crystal oscillator and a transceiver could be built. A prototype of this sort is being planned at this time, but time has not been available to start on it yet.

This is a very basic design that can be built with readily available parts in a small package. The sensitivity is good, selectivity is also good for three poles and the audio is loud enough for phones or a small speaker. Have fun building your CSS receiver. ●●

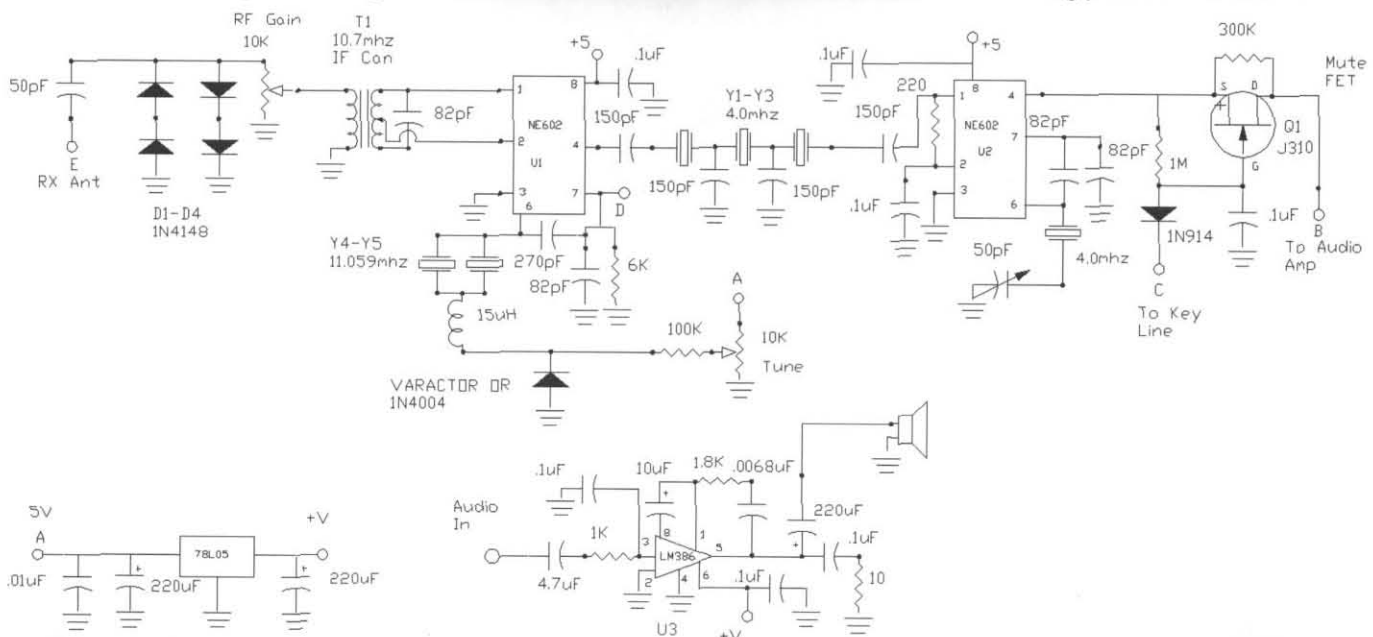

**Extreme QRP**

## Milliwatt Triple Crown Winners

Thanks to **John Burnley** of the Iowa QRP club and to **Bob Kellogg** of the Knightlites for all the hard work donated to make this great challenge such success.

1st place **N4ROA**--Dan Wolfe

2nd place **NQ5RP**--Ark QRP Club

3rd place **WQ4RP**--Knightlites QRP Society

4th place **W4LOW**--Grand Strand QRP Society

5th place **K1QM**--Joel Malman

6th place **NF0R**--Dave Gauding

7th place **KU4AF**--John Marshall

8th place **AB8DF**--Edward A. Kwik

9th place **WQ2RP**--New Jersey QRP Club

10th place **N4BP**--Bob Patten

**Congratulations to all!** ●●

[www.qrparc.org/](http://www.qrparc.org/)

*The QRP Quarterly*

April 01 13

# A Simple Multi-Band Attic Antenna

Victor Dively—KG4HTT

kg4htt@novaqrp.org

As a relatively new ham, I have experimented with a variety of small dipoles and loops in an effort to both work towards my DXCC as well as wanting to be able to ragchew on the lower frequencies in the evenings. Since I live in a townhouse, my antennas have to fit into a 21-ft. X 24-ft. space in my attic. Joining a local QRP club, the Northern Virginia QRP Club ([www.novaqrp.org](http://www.novaqrp.org)), put me in contact with a gregarious bunch of hams who were quick to share their knowledge and experience in dealing with this topic. I also gained some good friends. Definitely a great crew!

After getting started in the 40M Novice band, I quickly upgraded to General and started thinking about how to work DX. In addition to my SST40, DSW40 and my OHR100A/20M that I had constructed, I had borrowed a Ten Tec 580 Delta (thanks Pete!) which made me want to use more of the bands available to me with my new General license. The interest in a good broadband antenna became even more important once I purchased and started using the EZNEC antenna modeling program. In addition to being a great tool to analyze and design antennas, I also saw that having multiple antennas in my small attic space could cause pattern distortions and losses.

In looking for broad band antenna designs that I could use, I came across several articles in the ARRL *More Wire Antenna Classics*, Volume II, dealing with off center fed (OCF) dipoles. A section of the book dealt with the topic of the various feedpoints that could be used for an OCF dipole. While a feedpoint that is 33% from one end of a 68 foot long dipole is commonly known for resonating roughly on 40, 20 and 10 meters, I learned something new: a feedpoint at 41% or 17.4% from one end of the dipole would resonate on four frequencies – 40, 20, 15 and 10 Meters. That information, combined with other articles in various antenna books discussing the various ways to “fold” dipoles to fit into smaller spaces, got me thinking about a multiband folded dipole for my attic. So I decided to use the EZNEC modeling program to methodically explore various configurations whereby I could fold a 68-ft. long dipole into a rectangular shape no larger than twenty-one by twenty-four feet. I expected that there would be some loss of efficiency from folding an OCF dipole, but I was hopeful that I could find a design with minimum losses caused by

folding the dipole elements.

**EZNEC modeling:** I modeled eight basic shapes, ranging from a 17.5-ft. X 17.5-ft. square to a 24.5-ft. X 11-ft. rectangle. All the models kept a one-foot separation between the two ends of the folded dipole. I also incorporated two additional variables: varying the location of the antenna ends and feedpoint along the perimeter of the basic antenna shape, as well as trying two different OCF designs – one with the feedpoint 17% from one end, and one with the feedpoint 41 % from one end. By modeling different feedpoint locations with each feedpoint option for each basic shape, I ended up with a total of 126 antenna models.

I then created a spreadsheet that noted the maximum gain, azimuth and elevation for the radiation patterns on 40, 20, 15 and 10 meters. I also computed the gain for each frequency at a fixed radiation angle: 10 degrees for 10M, 12 degrees for 15M, 14 degrees for 20M and 25 degrees for 40M. As my primary goal was to maximize my ability to work DX on the various bands, I wanted to be able to compare all models not only at their maximum gain, but also at a consistent, relatively low elevation on each of the bands.

After making the spreadsheet, I noticed some recurring patterns. The 41% feedpoint OCF models had markedly higher gain in the various rectangular shapes for certain similar feedpoint locations, and the higher gain could be seen on several bands within the same design. After viewing the models, it became obvious that the high gain models looked like end fire arrays (EFA), similar to the “ZL Special”, but with an off-center feedpoint, as well as folded ends. I then designed several groups of models, changing one variable at a time, in order to determine which configurations (element length, element spacing, feed point location) maximized the gain for each of the bands. I discovered that the shape of the radiation lobes, the front/back ratio, and the azimuth of the main lobes on each band could all be predictably manipulated. I ended up with a 24.5-ft. X 14-ft. design giving me the highest gains for 15M and 20M, and good gain on 10M and 40M. Modifying the shape not only affected overall gain on each band, but also determined the azimuth of the strongest lobes for each frequency. The end result, after further fine-tuning, resulted in having coverage on several azimuths when the lobes

for all bands were added together. The maximum length of 24.5 feet was dictated by the floor space in my attic, and required some slight folding of the ends of the antenna (see Fig. 1). While I haven't found this design yet in any of my antenna books, it's so simple I'm sure that someone has tried it before. Until I know what else to call it, I'll refer to it as an OCF-EFA for this article.

Shortly after installing and operating with the antenna, I reconsidered one of my initial



Fig. 1—Initial configuration

assumptions used in determining the design parameters for my antenna models: that keeping the main elements flat and straight would produce the most gain in my attic. The flat design looked good on paper, and “worked” – I could contact Europe and South America – but it didn't seem to provide any noticeable improvement from other designs. The gain numbers suggested I should be seeing some noticeable improvement on the Central Europe azimuth, but that didn't seem to be the case.

In reviewing experiences with other antennas I had recently built, I had just recently noticed that my best antenna results occurred with designs where a long element hugged the roofline. These antennas seemed to outperform other antennas that should have been of equal performance. Since I live in an all brick townhouse, and have masonry firewalls between adjoining units, it appeared that flat design antennas, necessarily built a couple feet above the floor of the attic, while being above the brick exterior walls, required any broadside low angle radiation to penetrate one or more of the between-unit masonry firewalls in order to reach my antenna.

The azimuth for Central Europe/Middle East, about 35 degrees magnetic from my location, is directly broadside to my home. With an antenna that was built near the attic floor, where I had the most straight line space, all low angle radiation except that originating from South Africa or Japan would have to traverse all or portions of the masonry firewalls separating the townhouse units. But for any



antenna that hugged the roofline, and stood off a few feet from the masonry side walls, low angle radiation from any direction only needed to pass through a standard plywood/shingle roof.

**Try again:** This led to design number two. That's the nice thing about copper pipe antennas – with a pipe cutter and five minutes, your last antenna is turned into fresh stock for a new design! I bent the long elements so that the antenna could parallel the roofline, creating a shallow “inverted Vee” version of the EFA (see Fig. 2). Very simply, it is two elements 28-ft. 8-in. long, separated by a 12-ft. 9-in. section. This middle piece is connected at one end to one of the beam elements by a 90 degree copper elbow. Together, the longer element totals 59% of the total antenna length and the single 28-ft. 8-in. beam is 41% of the total antenna length. The total antenna length, 70-ft. 5-in., represents the length of a resonant 40M dipole. The antenna is fed at the open corner where the unconnected beam meets the 12-ft. 9-in. segment. If you trim the elements a little to tune the antenna, remember to preserve the 59/41 ratio – such as trimming six inches off the longer element and four inches off the shorter element.

The reason for the off center location of the bend in the elements is the incursion of a cathedral ceiling into my attic space. A 45-degree elbow worked perfect in my case for creating the bend at the roof peak. Since following the roofline gave me a few more linear feet for antenna length, I was able to eliminate the folded ends of the first design. In the end, the theoretical losses from bending the antenna into the less than optimal inverted Vee design were offset by gains due to the now longer element lengths. And the slight increase in average height for the bent antenna lowered the angle for the main radiation lobes by a degree or two, which was a step in the right direction. (For example, on 15M, the flat EFA showed a gain of 10.18dBi at its radiation angle of maximum gain, and 8.23dBi at twelve degrees elevation. The bent EFA shows a 0.57dB lower maximum, but has 8.66dBi gain at twelve degrees – a 0.43dB improvement over the flat design.) By this time, my EZNEC files and antenna gain spreadsheet listed statistics for about 250 variations on this folded OCF dipole/EFA theme.

**Success!** Changing the design to a roofline version made a dramatic improvement, and helped me to realize the potential with this

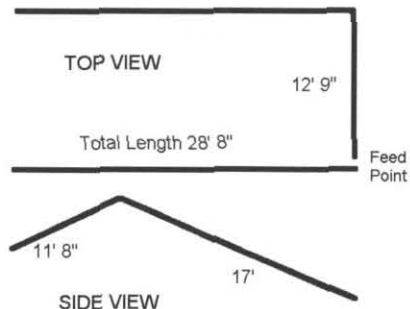

**Fig. 2—Final configuration**

design. My first day of using the new antenna started off nicely, with a QSO with an op in Egypt on 12M, a new DX country for me, and tied for my most distant QSO to date. I picked up another new DX country, Netherlands, on 10M, then hit a milestone I had been looking for – my first QRP/QRP DX QSO, to Sweden on 10M. I turned the power down to 2 watts and completed the QSO with no problems. I worked Europe on 21M and 17M during the day, then had another first early in the evening – my first QRPp DX, to Argentina, on 10M (the 10M pattern shows three significant lobes – pointing towards Asia, Europe and South America). I had forgotten to adjust the power setting after switching bands, so when I answered the CQ from Argentina, the needle didn't make it up to one watt. But I didn't need to repeat any of the QSO, so it was enough. I also worked Denmark on 30M.

But I've saved my best QSO for last – for the last few months, I've wanted to work Asia, especially Japan. I'd only heard a JA station once, and it was weak and barely readable. Well, that evening this antenna did the trick as I picked up a QSO with a JE from Tokyo on 10M! (I made sure I had my full five watts to try that one!) My new longest distance QSO, and my most exciting one to

date.

**Looking at the numbers:** The following table, based on models created with EZNEC (gain figures are dBi at optimum elevation and dBi at a uniform elevation, for purposes of comparison) shows the theoretical results for version two as well as version one. All gain numbers are based on a 30 feet height for the feedpoint, the actual height for my location. The bent EFA rises up to 38 feet, then down to 33 feet, in following the roofline. The same ground loss parameters were used for all the EZNEC models.

As you can see, except for 10M, and to a small respect on 40M, I have not lost the gain of an OCF dipole. For the 15 and 17M bands, there actually is useful gain over an OCF dipole. The bent EFA either equals or surpasses the low angle performance of the flat OCF-EFA except for 40M.

The models show that the OCF-EFA, even when at the same height as a dipole, has a lower angle of maximum radiation. The bands that work broadside to the main elements (15 - 20M) show significant low angle gain (2.4 - 2.7dB) over dipoles due to the end fire array aspects of the design; 10M, 12M and 30M, with their main lobes 35-45 degrees off from broadside, provide approximately one dB low angle gain over a dipole, while on 40M this design essentially performs like a folded dipole, with a minor loss in efficiency over a straight dipole. This is seen in the fact that the azimuth for maximum gain on 40M is parallel to the beam elements (Fig. 3).

**Construction:** I used one-half inch copper pipe in the computer model, and also for my final construction, as it showed very little difference in gain compared to using one inch copper pipe. The one-inch pipe

**Table 1. EZNEC Computed Gains**  
Gain in dBi, maximum / low angle (at angle specified)

Band	Reference Dipole	41% feedpoint, 68' OCF dipole	Flat OCF-EFA (Fig. 1)	Bent OCF-EFA (Fig. 2)
10M	6.8 / 5.2 @ 10 deg.	9.1 / 7.8	7.9 / 6.1	7.4 / 6.4
12M	7.2 / 5.5 @ 11 deg.	8.0 / 6.5	7.9 / 6.3	7.5 / 6.3
15M	8.1 / 6.0 @ 12 deg.	8.2 / 6.4	10.2 / 8.2	9.6 / 8.7
17M	7.9 / 5.5 @ 13 deg.	8.6 / 6.2	10.0 / 7.5	10 / 8.1
20M	6.2 / 2.7 @ 14 deg.	7.3 / 3.9	7.7 / 4.1	7.8 / 5.2
30M	5.4 / 2.3 @ 20 deg.	5.8 / 2.7	5.5 / 2.9	5.3 / 3.3
40M	6.3 / 2.5 @ 25 deg.	6.3 / 2.5	5.2 / 1.7	5.4 / 1.6

showed possibly 0.1 - 0.2 dB improvement – not worth the extra cost or difficulty in construction. Seventy feet of half-inch copper pipe is only about twenty five dollars at the local hardware store, so the antenna is cheap as well as easy to construct. Be sure to use steel wool to clean the pipe ends and connectors prior to soldering, and to use electrical solder, not plumbing solder.

**Feedline and SWR for seven bands:** I used an Autek Research VA-1 to measure the SWR for my completed antenna. I'll note that my SWR readings are generally lower than the model predicted. My measured resistance at resonance on 40M was higher than the model predicted (that's a good thing, for matching purposes, but I'd like to know why the resistance was higher), although the resonance points seem to be roughly as predicted.

The result was lower-than-predicted SWR on some bands except 20M. On another technical note, the OCF article in the ARRL *More Wire Antenna Classics* pointed out that the exact resonance points depend not only on feedpoint location, but also on wire, height, antenna shape, and all the usual factors that change impedance figures. The result was that the OCF-EFA model showed slightly different resonance points than the OCF dipole model. But the bottom line, as seen in the actual figures, shows an SWR curve that makes tuning up on all the bands quite easy. The SWR was measured at the tuner end of the 10-ft. feedline. When running the SWR graphs on EZNEC, 450-ohm ladder-line gave the lowest average SWR for all the bands, so that was my choice for the feedline.

**The 80M option:** I've had good success using small loops (70-100 feet circumference) for 80M. In an effort to avoid possible interference, I had torn down my latest loop when installing this antenna. However, clipping a 13 feet long wire to the ends of the beams makes the antenna an 84' circumference horizontal loop. A quick check on 80M, using the antenna as a loop, and a one hour QSO with another QRP'er confirmed that this antenna also works in that capacity.

**Conclusion:** So, whether you are required to keep your antenna farm indoors, you would like a back-up antenna, or you are curious and looking for another excuse to play with antennas, consider this basic design for a broadband gain antenna. Adapt it to your space and see what you can do. Good luck! ●●

Band	SWR
10M	2.5
12M	1.06
15M	2.7
17M	1.6
20M	10.0
30M	4.8
40M	4.7

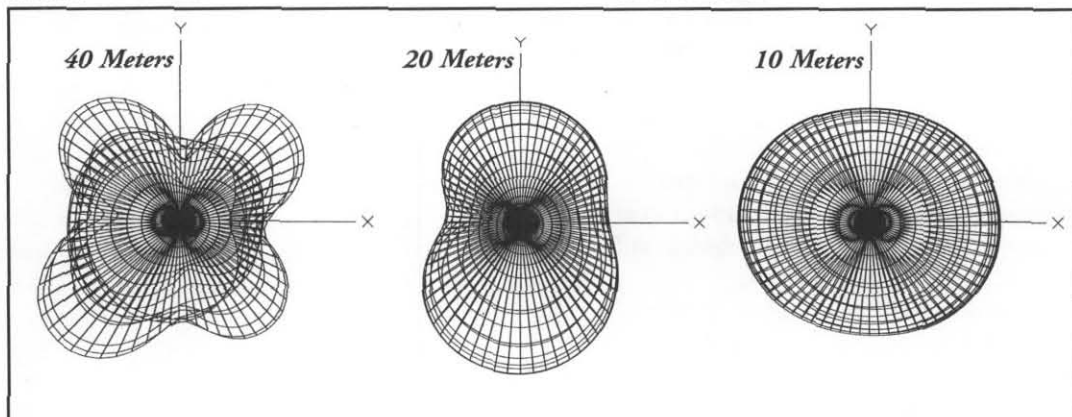

Fig. 3—Examples of EZNEC calculated radiation patterns for OCF End-Fire Array Version 2.

## A Quick Look--Patcomm's New 500 Transceiver

Jim Stafford—W4QO

w4qo@arrl.net

We've been hearing for some time about a two band completely assembled transceiver from Patcomm. I was fortunate to be able to borrow an early version of this rig for a few days of use. I don't have any real "lab" tests to report but I can give you a look at some of the features and how it feels on the air.

**Jim Idone, KE2TR**, from Patcomm and I were discussing the new rig when he offered to send one along. I've heard around the bands, the clubs, and the lists that folks might like to have an economically priced small rig that is already built. Well, here it is. Here are some first impressions after a few contacts, some during the ARRL DX test until someone else does a thorough review.

The rig has all the requisite "basic" features such as VFO A/B, RIT/XIT and can accommodate any two bands between 160 through 6 meters, the latter being noted by our Technician members, I'm sure. It operates SSB plus CW from less than 1 watt to

15 watts. The variable 600 to 3 KHz audio filter does a good job of cleaning out the adjacent signals from an operator's standpoint. It is a 16 pole filter, said to rival DSP type filters. I found it to be very effective.

The rig has a built in keyer and a unique interface that takes a PC keyboard. Using the keyboard, you can send CW or you can access the 4 memories per band from the keyboard. It can also be used for changing bands, or entering frequencies directly. I found the CW to be a bit choppy for my taste and I have relayed this to the company. I have been advised that this is being addressed in the production models—mine was an "engineering" model. If I owned this rig, I would look for a very small keyboard to use with it out in the field as it is a quite handy feature.

The rig is not billed as a "low current" rig. Like some other rigs that use processors and displays, the current is on the high side for a "backpacking" mode but it is certainly

light enough, weighing in at 4.75 lbs. The rig uses .75 amps on receive and about 5 amps at 15 watts transmit. But for many of us (read senior citizens!) who do our hamming in the field near a vehicle of some sort, this rig could be packed to go in a small bag and set up quickly near the car/truck battery. Or it could even be used directly from the vehicle as a mobile rig with the 15 watt power level providing that extra boost during tough band conditions.

Being a SSB rig, it can be used for such digital modes as PSK-31. Jim sent me cables to hook to my computer to test this mode but I didn't have time to get it all going before this writing. He assures me it does work!

Keep an eye on this rig. It could be the answer for those who are beyond their kit building years or it doesn't interest them any longer. The 500 is priced in the \$400 range equipped with two band modules. Additional modules are about \$35 each. ●●

# Picturing the Rest of Your Antenna System

## A Homebrew Circuit Simulator with a QRP Twist

Dan Maguire—AC6LA

ac6la@arri.net

It's getting so you can't pick up a ham radio publication of any sort now days without seeing at least a few azimuth and elevation charts created from popular antenna modeling software like EZNEC or NEC-Win Plus. Using an antenna modeling program can be very addicting and I'm as guilty of this as the next ham. I love to bend and tweak and prod and poke the design on the computer and look at the "pictures" to see what the results will be. I've even been known to actually go out and build some of these creations, although I'm pretty embarrassed (and maybe you are too) at the lopsided nature of the "antennas designed" to "wires in the air" ratio.

But there's more to your antenna system than just sky wires or aluminum. Everything from the antenna feedpoint connection all the way back to the rear panel of your station rig contributes to (or more likely, detracts from) that great design you had on the computer. It's nice to be able to "see" that part of your antenna system as well.

The usual way to do this is via Smith charts. Although computers can generate vast quantities of seemingly invincible numbers, nothing beats a Smith chart for getting a visual understanding of what's happening along transmission lines and through various antenna tuner components. I wanted a graphical view of the rest of my antenna system, so I built (using Microsoft Excel) a circuit simulator with Smith chart capability in order to model and "picture" all the system components from feedpoint to rig.

### Off the Shelf versus Do It Yourself

I chose to use Excel for this project mostly because I was already familiar with Excel and it's charting capabilities. I bet there are hams out there who have implemented something similar to this using Mathcad, and for certain it's been done before in more conventional computer languages.

There are also many fine commercial Smith chart programs, including ARRL MicroSmith, EagleWare winSmith, ARRL Radio Designer, and Radio Designer's big brother (actually more like a rich uncle once removed) Ansoft Serenade. (References are listed at the end of this article.) On the internet, just the most casual search will yield several freeware, shareware, demoware, low cost commercial, and not so low cost com-

mercial programs that all have Smith chart and/or circuit simulator capabilities. With all these choices available, why on Earth would anybody want to do a homebrew version?

Let me answer that by talking a little about QRP. I enjoy many of the operating aspects of QRP, but what I really like is the opportunity to build and tinker with things. There's no way I could ever actually design a complete 40 meter CW transceiver, but I sure do learn a lot by building one. I learn more when it doesn't work the first time and I have to follow the circuit diagram to find where I might have put a component in wrong. And I learn even more (and have a lot of fun learning) when I make even simple modifications to the rig, cutting a few circuit board traces here or adding some bells and whistles over there.

It's the same with a circuit simulator. By building one yourself you gain an immense amount of knowledge, even if your creation will never rival a commercial offering. You certainly have a lot of fun acquiring that knowledge along the way. And you are free to implement and include features that you want to investigate or learn more about, all with as much or as little detail as you like. Just like building a QRP rig.

### So What's It Do?

Here's an example of what the package can do, with "pictures." The scenario will be to start at the feedpoint of a typical backyard antenna and show on a Smith chart everything that happens all the way back to the station rig. Just as an example, I've chosen an 80 meter dipole (total length about 126 feet) that is now being fed with 50 feet of 450 ohm ladder line and a tuner to provide multi-band coverage. In this case we'll see what happens when the antenna is used for it's original purpose, namely in the 80 meter band.

To start this example we need the antenna feedpoint impedance values in the form of  $R \pm jX$  at several different frequencies. The Frequency Sweep (or similarly named) function of any antenna modeling package can provide this data. The circuit simulator can read the output files produced by NEC-Win Plus, EZNEC, and several of the generic NEC packages available on the internet, or

you can manually enter the data points. By the way, getting started with an antenna modeling program is fairly straight forward. If you've never used one, do yourself a favor and take a test drive of EZNEC (by Roy Lewallen, W7EL) or NEC-Win Plus (by Nittany Scientific). Both are available (with certain time limit and/or model complexity limitations) as no-cost demo versions from the web.

We'll pick out just the impedance at the midpoint frequency of the 80 meter band ( $72.4 + j0$  ohms at 3.75 MHz) for the first few steps of the example. (We'll get back to the other frequencies later.) In our example the feedline is 50 feet of 450 ohm ladder line. A feedline serves to transfer RF from one place to another, but it also acts like an impedance transformer. That is, at any point along the line the impedance will be different from what it was at the antenna. Fig 1 shows this. The square marker indicates the load impedance of  $72.4 + j0$  ohms. The round markers, "walking" in a clockwise direction, show how the impedance is transformed at several points (automatically generated) along the line. (You can specify the line length in discrete steps of feet or degrees if you wish, or just let the program create a series of intermediate step values.) The box to the left of the chart shows the impedance and other information at any one of the plotted points. The buttons within the box may be used to sweep or step through the points, or you may use the mouse to double click on any point about which you want details. In this example the selected point is at the station end of the 50 foot line, indicated with an enlarged round marker on the chart.

There are two slightly unconventional things to note concerning **Figure-1**. First is that the center of the chart (Prime Center) is defined as 450 ohms. Although Smith charts are usually shown with an (implied) 50 ohm center, there are times when you may wish to use a different value. The program lets you set or reset any Prime Center value and updates the display automatically. The second thing to note is the scale labels. Usually these are shown as normalized values (0.2, 0.5, 1.0, etc.) but with a computer-generated chart there is no reason why these labels cannot be shown as "actual" as opposed to normalized. You may choose either style.

Continuing the example, if you're using ladder line as a feeder you probably have a combination balun and transformer on the back side of the your antenna tuner. (This simulator ignores the "balanced to unbalanced" part of the balun; it only models the transformer part.) Let's say the balun has a 4:1 transform ratio. The diamond markers of Fig 1 show how the balun changes the impedance to something else, this time walking counter-clockwise. The intermediate points were again automatically generated, ranging from a 1.33:1 transform ratio near the right side of the arc of diamond markers to the final 4:1 ratio at the left end of the arc.

Between the balun and rig you no doubt have a "T" configuration network of some sort. That's a capacitor in series, then an inductor in parallel (shunt), then another capacitor in series. **Figure-2** (now with a 50 ohm center) shows the impedance transforms that would take place first through the output capacitor (maybe labeled something like "C out" or "Antenna" on your tuner), then through the coil, then through the input capacitor (perhaps called "C in" or "Transmitter"). By now you've guessed that the intermediate points in the arcs were automatically generated, this time representing different amounts of capacitance and inductance. If you've set all the dials correctly, the result will be that the "trail" of Smith chart plot segments ends up right at  $50+j0$  ohms.

### Frequency Sweeps and Component Tuning

In the previous figures the Smith chart has shown how changing network element values (length of line, amount of capacitance, etc.) changes the impedance. Another use of the chart is to show the results of varying the frequency while keeping all the element values constant. Just as antenna modeling programs can calculate the antenna feedpoint impedance for a range of frequencies, the circuit simulator can calculate how all of these impedance values would be transformed by the feedline, balun, and tuner components. The chart gets pretty busy if all the segments are shown, so **Figure-3** just shows the antenna feedpoint (load) data and the final results after going through all five components of the feed system discussed above. Both arcs "walk" clockwise as the frequency increases.

**Figure-3** also has a 2:1 SWR circle marked. (The SWR circle markers were "turned off" in the previous figures.) The selected point (enlarged triangle marker) shows a 3.367 SWR at 3.6 MHz. You'd have

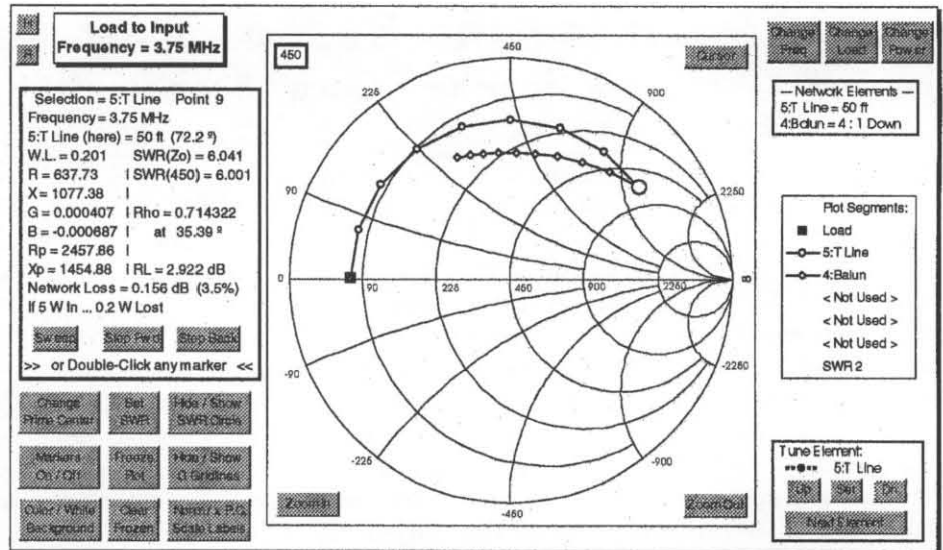

**Fig. 1—Impedance transforms along the transmission line and through the balun. Chart has a 450 ohm center.**

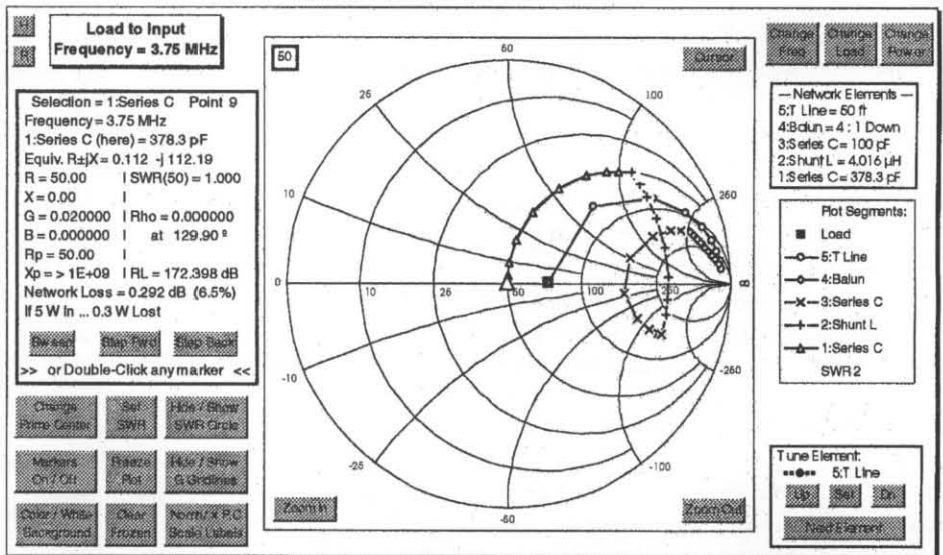

**Fig. 2—Impedance transforms continued through the "T" tuner elements. Chart now has a 50 ohm center.**

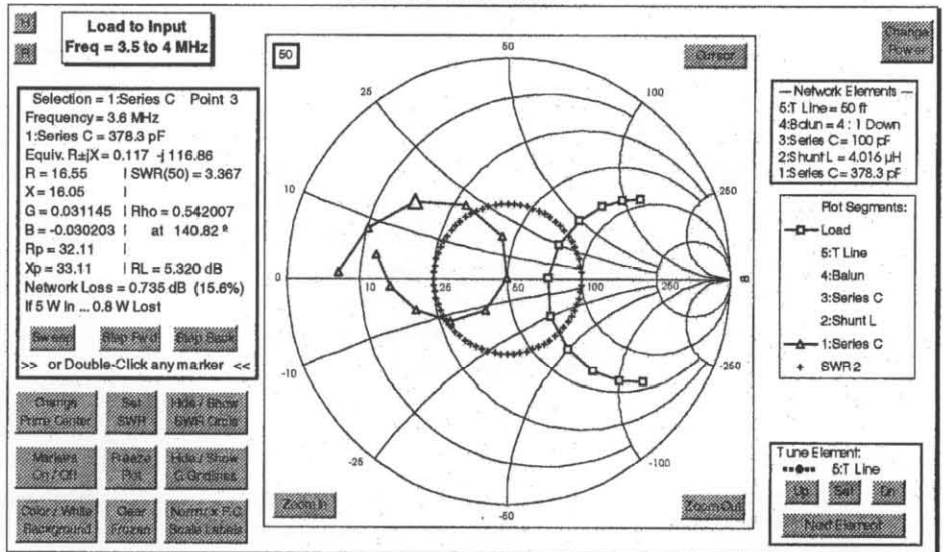

**Fig. 3—Frequency sweep from 3.5 to 4 MHz in 0.05 MHz steps. Markers show impedance at antenna feedpoint and after all network elements.**

to do some twisting of the knobs on your tuner if you wanted to get a low SWR when changing frequencies from one end of the band to the other.

There are several ways to “twist the knobs” in the simulator. One way is to manually adjust the values of the various network elements by using the buttons on the Smith chart sheet. (Look in the lower right corner of the figure.) Select the element you want to tune, then either use the Up/Dn buttons to increase or decrease the value in 10% steps or use the Set button to pick an exact value. After each button press the Smith chart is redrawn to show the results. This technique provides many insights when a “trail” of plot segments is shown on the Smith chart, as with **Figures 1 and 2**.

Another way to experiment with changing component values is to use a more specialized sheet that deals only with certain types of matching networks, without baluns and transmission lines. Fig 4 shows this sheet, which has a “numerical” rather than “graphical” flavor. For variety the example has been changed in this case to that of transforming a load impedance of  $25+j0$  ohms to a target input impedance of  $50+j0$  ohms. Four common networks are shown with worked-out approximate solutions. (The initial solutions are approximate, not exact, because component Q has not been factored in yet. Notice anything interesting about the component reactance values for the networks?) Using the approximate solutions, the Check boxes then show the results of doing a ladder analysis from load to input with component Q included. When you’ve decided which network to investigate further (in this case the “Hi Pass T”), the Fine Tune area allows you to try your hand at manually changing the component values (like manually twisting tuner knobs). But there is also another way.

Excel comes with a nice built-in tool called the Solver. The Solver will try various values for one or more specified input cells on a worksheet, looking for a combination that produces a specified target output cell value while (optionally) still other cells meet certain constraints. (It doesn’t just keep trying random solutions. Instead it uses certain numerical methods techniques to see how any given try gets closer to or farther from the desired answer, then adjusts the variable input cell or cells according for the next try.) You can use the Solver to “auto tune” your network to give almost any desired result. For example, you can specify

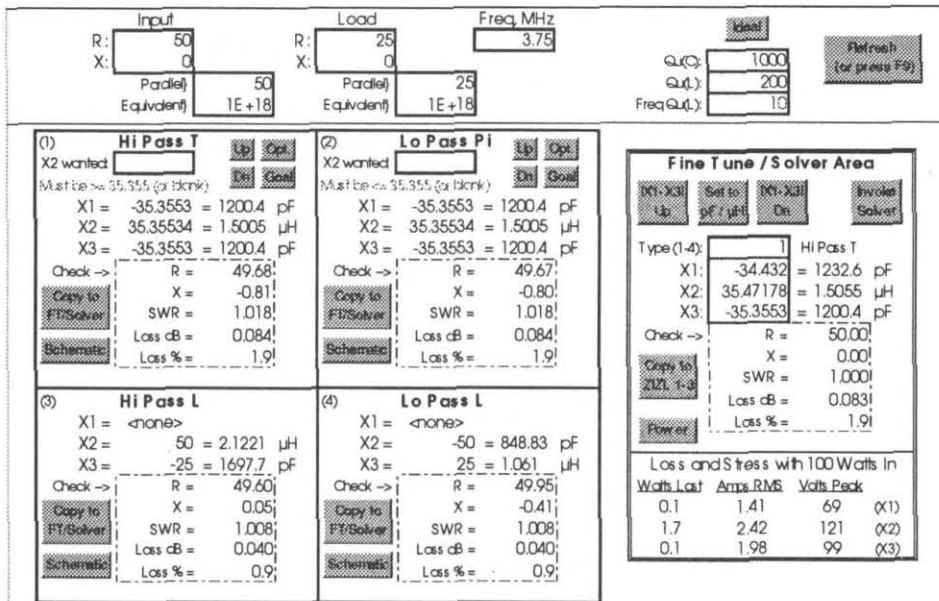
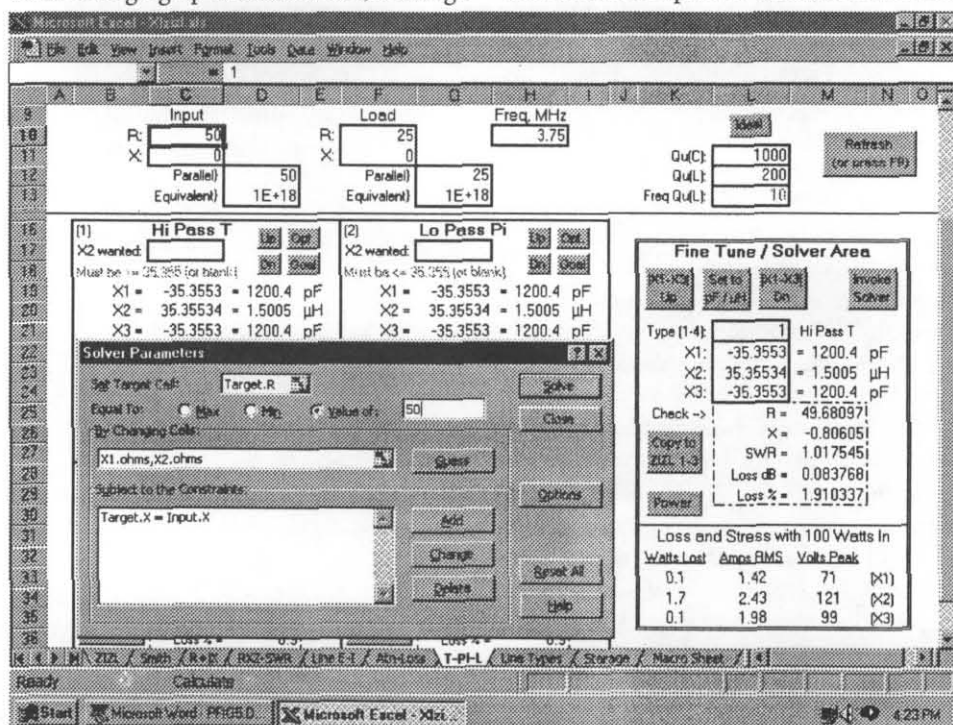

**Fig. 4—Numerical solutions for four common networks transforming  $25+j0$  to  $50+j0$ .**

“Keep one component at a fixed value and find an exact match with component Q included by varying the other two.” Or you can say “Vary all three components within these ranges but give me an exact solution with the lowest dB loss,” or perhaps “Limit one component to this value, limit the range of the other components to these bounds, and give me the solution with the lowest SWR even if it’s not an exact match.” (The Solver can search for minimums and maximums as well as exact targets.)

The ‘Invoke Solver’ button on the worksheet does some initial house keeping before bringing up the Solver tool, although

you can invoke the Solver (and a related tool called Goal Seek) at any time on any worksheet. Fig. 5 is a screen capture showing the Solver window with just one example of a particular problem to be solved; this was the problem setup used to produce the results shown in Fig. 4. (It must be mentioned that the Solver sometimes fails to find the “expected” correct answer, although it may find “a” correct answer. In general, the Solver is best used to “home in” on an exact answer after you have already set the input variables to at least approximate values.) Once you are done manually or automatically tuning the network component values, other buttons



**Fig. 5—Excel Solver with a typical problem setup.**

make it easy to generate Smith and other type charts.

### Another Way of Looking at Things

Speaking of other types of charts, I didn't just wake up one morning and figure out how to create a Smith chart with Excel. It took some reading and digging, but mostly it was standing on the shoulders of several hams who had been kind enough to share their work in public. (And by writing this short article I hope to repay in small measure the debt of gratitude I owe them.) Early versions of this package just plotted R and X values on a standard rectangular grid pattern.

It turns out I was in good company. In doing the research for this project I purchased a copy of Phillip Smith's book and discovered that his original charts were also just standard rectangular grids showing R and X. There are some disadvantages to showing impedance this way (like having equally stepped frequencies bunch up on one side of the chart), but when shown in this manner the charts are sometimes more intuitive. I decided to leave this type of chart in the package since I found myself looking at it from time to time.

Figure-6 shows an example. The plot segments represent the three components of the "Hi Pass T" network of Figs 4 and 5 (load  $25+j0$  transformed to input  $50+j0$ ), except in this case we'll use ideal components with no losses. Network element 3 is the series output capacitor. Fig 6 shows that this component (x markers) only changes the reactive part of the load impedance as the amount of capacitance is changed. (The plotted points move straight down from  $25+j0$  ohms.) That makes sense, as starting with  $25+j0$  ohms and adding  $0-j35.36$  in series results in  $25-j35.36$ . The R part hasn't changed. But when this impedance of  $25-j35.36$  is combined in parallel with the inductor (final inductor reactance is  $0+j35.36$  ohms) both the R and X parts change as the amount of inductance is changed. The middle plot segment (+ markers) shows this. (The plotted points "walk" counter clockwise.) Even though element 2 is a pure reactance X, when combined in parallel with  $25-j35.36$  the result will show a change in both R and X. The R part of the combination starts at a value of 25, progresses through a value greater than 50, and ends up right at 50, all as a result of parallel combining just different amounts of X. And now it's pretty obvious that the only job left for element 1 (the series input capacitor, triangle markers) is to get the X part of the impedance back to 0, as the final plot segment shows.

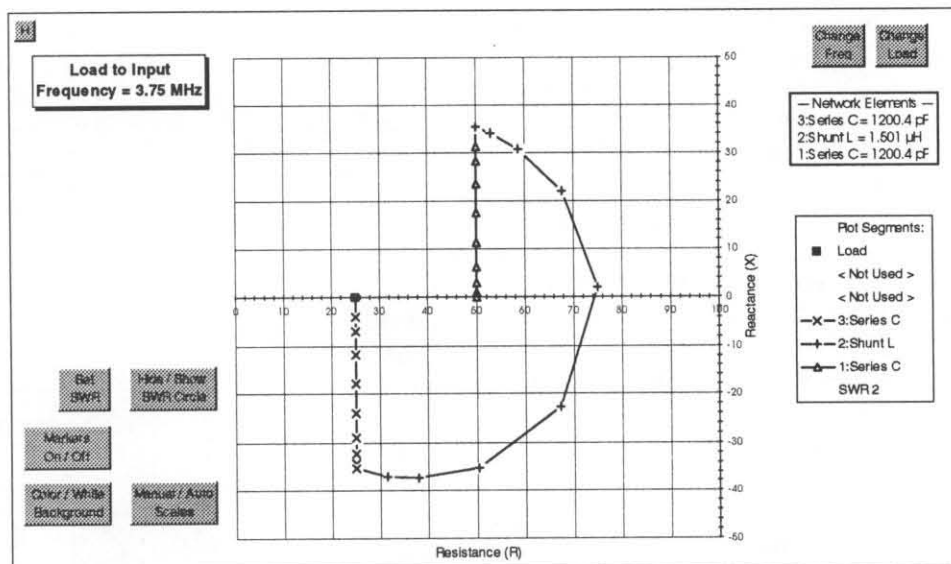

Fig. 6—An alternative way of showing impedance transformations through a "T" tuner. Load is  $25+j0$  ohms. Elements have no losses in this example.

Starting at  $50+j35.35$  ohms and adding  $0-j35.36$  in series results in  $50+j0$ . (Again the plotted points move straight down.)

Of course the same situation is presented on a standard Smith chart (and becomes more obvious when the conductance G grid is shown), but sometimes with all the curved grid lines, non-linear scales, and possibly normalized labels things start to get a little confusing.

### Nuts and Bolts

On the main worksheet of this package (not shown here) you can enter any number of Frequency, R, and X sets (from 1 up to a maximum of 255). These can be impedances at either the load side or input side of your network, and there are several ways to automatically create entries in addition to reading data files from antenna modeling packages.

You can specify any arbitrary network consisting of between zero and five elements. (You may wish to use zero elements if you merely want to plot impedance information from an antenna modeling program in the various formats available in this package, such as Smith chart, Rectangular R and X, R/X/Z/SWR versus frequency, etc.) The elements can be transmission line sections, step-up or step-down baluns (modeled as ideal transformers), series or shunt capacitors, series or shunt inductors, series or shunt resistors, open or short circuit terminated transmission line stubs (parallel connected), or series or shunt special "combination LC" elements consisting of an inductor and capacitor pair connected together in either series or parallel. (These "combination" elements come in

handy when modeling elliptic and band-pass filters.)

Each transmission line or stub element (if any) may be independently defined as to characteristic impedance, velocity factor, and attenuation. Parameters for approximately 40 different lines from various manufacturers (Belden, TMS, Wireman, Andrew, Tandy, etc.) are built in or you may define custom lines. Lines and stubs are modeled with the full hyperbolic tangent transmission line equation and account for loss at varying SWR levels and varying frequencies. Losses for capacitors and inductors are modeled via the specification of an unloaded Q for each type component; losses for both types are frequency compensated.

You are limited to simulating up to five network elements at any one time, but that does not mean you are limited to five as the total number of elements in your system. For example, suppose you have a vertical antenna with a simple L matching network at its base, then a run of coax to the shack, then perhaps a CLC tuner to give broad band coverage. The package makes it easy to first model the two components of the L net at the antenna, then use this set of transformed impedance values as the "start point" for modeling the remaining four elements of the system.

### Heat Up the Soldering Iron

This article has shown just a few examples of what you can do with this circuit simulator. There are several other functions and charts that I have not described. You can experiment with transmission line series sections and stubs, both for matching and

harmonic rejection. Or you can see how component Q values change the "textbook" curves for attenuation, passband ripple, and SWR for various types of passive filters. Another interesting application is to have your antenna modeling program generate feedpoint impedance data for a given antenna over the range of 1 to 30 MHz in small steps, then study the system response at various harmonics of the intended operating frequency.

With this package you can now have almost as much fun "modeling and picturing" the rest of your antenna system as you do with the antenna itself, and of course you are free to do just that. But what you might want to do in addition is to get out the (virtual) soldering iron and wire cutters. Perhaps use what I've presented here as a starting point to create your own simulator. Make changes, add new functions, break some things and then figure out how to fix them. Maybe build a prototype using a completely different structure such as with Mathcad. You may find, as I did, that it's a lot more fun and rewarding to do it yourself.

And when you've got something working that you think maybe a few other hams would like to see, by all means share it with us! That's the spirit of QRP, and Ham Radio in general, at its finest.

## References and Notes

For more on the commercial products men-

tioned in this article, see: [www.eznec.com](http://www.eznec.com) (EZNEC); [www.nittany-scientific.com](http://www.nittany-scientific.com) (NEC-Win Plus); [www.noblepub.com/Noble/Winsmith.html](http://www.noblepub.com/Noble/Winsmith.html) (winSmith); [www.arrl.org/ard/](http://www.arrl.org/ard/) (ARRL Radio Designer, no longer available); [www.ansoft.com/products/hf/serenade/index.cfm](http://www.ansoft.com/products/hf/serenade/index.cfm) (Serenade, including a student version called Serenade SV available for free download). ARRL MicroSmith is no longer listed for sale on the ARRL web site.

For more on using the Smith chart: Both *The ARRL Antenna Book* and *The ARRL Handbook for Radio Amateurs* have sections explaining the use of the Smith chart. A very nice tutorial is in the form of a demo version of ARRL MicroSmith which is included in the *Handbook 2000* companion software, available for download at [www.arrl.org/notes/1832/#software](http://www.arrl.org/notes/1832/#software). Yet another very complete tutorial is found in the final chapter of the second edition of Smith's book (see below). This newly added chapter is the User Manual for winSmith, but makes a good introduction to the Smith chart even if you don't have that software package. (I don't.) For a more advanced tutorial see William Sabin, "ARRL Radio Designer and the Circles Utility Part 1: Smith Chart Basics," *QEX*, Sept/Oct 1998, pp 3-9. (Copy of this article is available for download at [www.arrl.org/ard/ardarts.html](http://www.arrl.org/ard/ardarts.html).) For tutorials and software on the internet try starting at [sss-mag.com/smith4.html](http://sss-mag.com/smith4.html), or enter "Smith chart" in almost any search engine.

Smith's book was originally published by

McGraw-Hill in 1969. A second edition is now available: Phillip H. Smith, *Electronic Applications of the Smith Chart in Waveguide, Circuit, and Component Analysis*, Noble Publishing, 1995. ([www.noblepub.com](http://www.noblepub.com))

**Ladder line:** Although shown as 450 ohms in this article, window ladder line usually has a somewhat different characteristic impedance. For more on this topic see Wes Stuart, "Balanced Transmission Lines in Current Amateur Practice," *The ARRL Antenna Compendium Volume 6*, pp 174-178.

**Package availability:** The Excel application described here is available free by sending me an email. The sheets are not protected or locked in any way. You are more than welcome to "mess around under the hood."

**Computer requirements:** You must have Microsoft Excel 97 (or later) installed on your computer. You may need to apply one or more Service Releases and/or patches, available free from the Microsoft web site. Your display must be configured as either 800x600 (small fonts only) or 1024x768 (small or large fonts) resolution (or greater) with 256 (or more) colors; 640x480 resolution is not supported. Of course more computer horsepower is always nice, but I must admit (with bowed head) that I'm still using an old 486 machine with a slow processor, not much memory, and a perpetually-full hard drive. Anything manufactured after the time when Bill Gates made his first billion will probably work just fine. ●●

# Confessions of a New DX Hound—QRP Style

Steve Melachrinos—W3HF

[melachri@voicenet.com](mailto:melachri@voicenet.com)

"ZL-4Z-OH-PJ-ZS-W4" Maybe a secret code to some, but to me it's "Worked All Continents." And I did it all QRP using an indoor dipole. Here's how.

I had been an inactive ham for almost 20 years—so inactive that I bought a house in a community that prohibits outdoor antennas. So when I went through the license upgrade last year and decided to try out the new call sign, I had few options. I also didn't want to invest too much in discovering if I really enjoyed this stuff anymore. So an inexpensive QRP rig seemed the right approach, and the PSK31 mode was the opportunity to get back on the air without "advertising" my lack of operating experience. The Small Wonder Labs PSK-20 set me back only \$130. As for the antenna, it's tough to do much on 20 m in an attic other than a dipole, so that's what I used. An MFJ tuner rounded out the radio gear. I completed the PSK-20 kit and verified that the smoke would stay inside just after last Thanksgiving.

[www.qrparci.org/](http://www.qrparci.org/)

My first contact was P43RR—hey this DX thing is neat! A few days later I made it across the Atlantic to Europe — first France, then Spain, Italy, and Ireland. This was getting interesting! (Gotta learn this propagation stuff to figure out when the band is open to where.) Then I started working deeper into Europe, eventually to HB, S5, OK, OE, and SP. More South American stations showed up in the log—PZ, CP, PJ, YV, and LU. Finally, in rapid succession came ZL3JT, ZS6PJK, and 4Z5LR—WAC in 31 days! And all on 3 watts, an indoor dipole, and 3 kHz of operating range. (The PSK-20 is crystal-controlled.) DXing this way is like trying to look at the world through a keyhole!

I guess I've discovered I have this DX disease pretty bad. I have 54 DXCC entities in the log, 24 confirmed so far. (That doesn't include the QSO with PY0FT. Tony heard me and logged me, but must have had the call sign wrong [W3H?], so the QSL came back "not in log." Darn — I have to remem-

ber that if I can barely hear him, he's having it worse hearing me. Phonetic spelling is interesting on PSK.) I've gotten to where I almost don't bother responding to CTs and EA8s calling CQ — I want that new country. High points include finding band openings — first to Africa one day and working CN8KD, 7X4DR, and ZD7MY back-to-back, and then SP6FPD, GJ4JVP, and OZ7AD a few days later.

Here are the lessons learned so far. Maybe they're obvious, but they are even more important to the QRP'er.

1. The character-coding scheme for PSK uses shorter codes for lower-case letters than for upper-case letters. Consequently, messages transmit about twice as fast when using lower-case rather than upper-case letters.

2. Although call signs "look" better in upper-case letters, you can often get your call sign on the other ham's screen quicker and with a lower error rate if you use lower-case

--continued on page 31--

# A Versatile Remote Control Antenna Tuner

## Keep Your Tuner in its Place!

John Cumming—VE3JC

ve3jc@rac.ca

Over the past few years, we have seen the introduction of some wonderful antenna tuners. With the evolution of “smart” automatic tuners, and the increasing tendency to locate these ATU’s within the rig itself, we have become more likely to ignore the fact that the tuner “ain’t where it otta be”. The internal ATU may do a fine job of making the rig “see” a 50-Ohm load, thereby assuring maximum power transfer to the feedline. However, it will do nothing for mismatches between the feedline and the antenna, and the resulting power losses.

Some years ago, I began to look at putting up an inverted “L” or shortened vertical for 160 and 80 meters. The feedpoint for the antenna was to be located at the highest, most “in the clear” spot in my back yard, about 250 feet from my shack. I certainly had no desire to see my long run of “low loss” RG-213 burning up my precious milliwatts because of feedline / antenna mismatch! Initially, I located a manual tuner at the antenna base. This consisted of an air variable capacitor and an “air dux” inductor with alligator clips for adjustment, all mounted in a plastic tupper-ware enclosure. While this permitted operation in a very small portion of the 160 meter band, it only took a single late night midwinter tuner-adjustment expedition (in my pajamas!) to realize that something better had to be done.

I looked at a number of articles [1]<sup>1</sup> which described clever schemes, using relays and tapped coils to permit remote band-switching and fine adjustment. Each design was specific to a particular antenna. Because I intended to try a variety of “vertical” antennas over time, I wanted to build a remote tuner that provided maximum versatility. Using a low loss variable capacitor and roller inductor, it would need to be easily reconfigured and adjusted from the comfort of the shack, and would provide a visual indication of the tuner’s current configuration and component adjustment.

This article describes the remotely controlled antenna tuner system that has evolved at this southern-Ontario QTH. And I know what you’re thinking ... You’ve peeked at the photos of my remote tuner (**Figure. 1**) and the control box (**Figure. 2**), and have already decided that this is one of those “how to” articles which requires parts no longer found

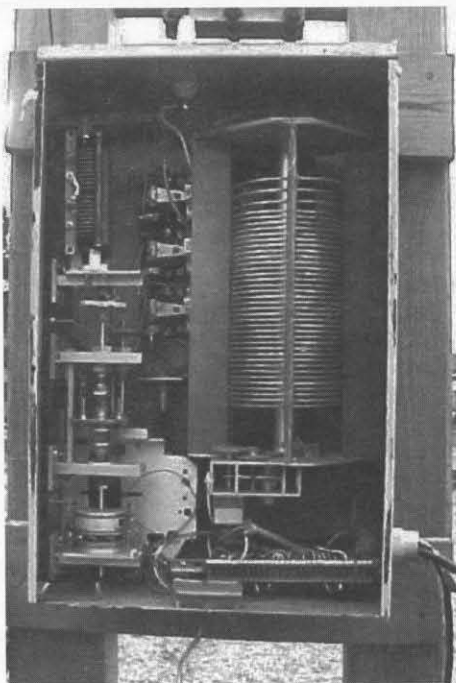

Fig. 1—Internal view of remote antenna tuner.

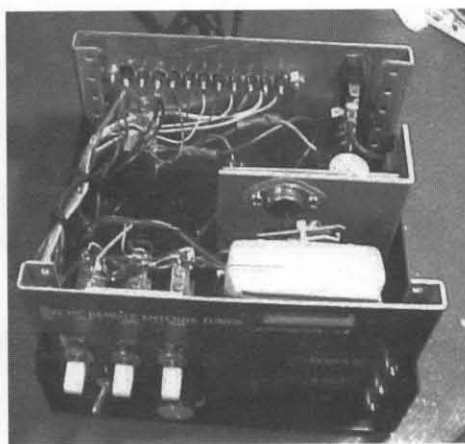

Fig. 2—Internal view of control box.

on the planet! *All* of the parts needed can be procured in several months of pleasant flea market browsing, garage sale shopping, and junkyard scrounging. I admit that, instead of working from a highly specific parts list, you will have to incorporate the best components you’re able to find and make whatever accommodations are necessary in the rest of the circuit. This is true “homebrewing”, and the source of a great deal of enjoyment.

You are going to need low-RPM DC motors to drive the variable capacitor and roller inductor. If you’re lucky, your junk box contains two nice 12-volt motors with lots of torque and the ability to “stop on a dime”. On the other hand, you might have to scout

out neighborhood garage sales for cordless screwdrivers that no longer hold a charge. You would then need to accommodate any difference in operating voltage between your power supply and your screwdriver motors.

The major components you require (beginning with the most difficult to find) are as follows:

❑ **Roller Inductor.** These are becoming scarcer, but can still be found. How big do you need? As you can see from **Fig. 1**, my 37-turn 5-inch diameter (approximately 85  $\mu$ H max) Collins-made inductor is definitely “overkill”.

❑ **Air-Variable capacitor.** Also becoming scarcer. As with the inductor, go with the best quality unit you can get. I used a 550 pF capacitor; the ultimate tuning range using various “L” tuner configurations will depend on the range of inductance and capacitance available.

❑ **Drive motors.** See above. These must be capable of rotation in both directions by polarity reversal, and should have equivalent operating voltage.

❑ **Gears, insulated couplers, vernier drives, and “universal” couplers.** Here I am going to be extremely vague. Brass gears for 1/4-in. shaft mounting, ceramic couplers, and gear drives from old boatanchors are often found in those miscellaneous junk boxes at fleamarkets. When you come across these mechanical gizmo’s, offer the vendor twenty five cents and take them home! For this project, the objective is to get the motors to turn the capacitor and inductor at a reasonable rate (about one RPM and 20 RPM respectively) and to drive potentiometers for position indication. The large gear drive visible below the capacitor in **Fig. 1** was acquired at a flea market for less than a dollar.

❑ **Potentiometers for position indication.** A single turn 20K pot for the capacitor and a 10 turn 10 K pot for the roller inductor will give a 0.0 to 10.0 reading for the full adjustment range of each device. Unless you happen to use a 10-turn roller inductor, you will need to gear the pot drive so that full travel of the roller inductor corresponds to full travel (or slightly less) of the pot.

❑ **Cables.** Now this is an easy one! Retrieve those frayed outdoor extension cords from your neighbor’s garbage and repair and seal as necessary. When you have enough



for three runs between the shack and your tuner location, you're in business. Alternatively, eight-conductor rotor control cable can be used.

❑ **Power supply.** Assuming that 12V motors and relays are being used, you may already have a suitable self-contained regulated power supply in the shack. My original intent was to provide a jack on the control box for connection of such an external supply. However, a 15V, 3A power supply module was obtained and installed internally. The voltage adjustment pot on this regulated supply has come in handy for accommodating my tuner's lethargy during the very cold winter months!

❑ **Digital position indicator** (AKA digital multimeter!). Again, my intent was to provide jacks on the control box, and connect my bench-top multimeter whenever I was using the tuner. But when a very inexpensive autoranging digital meter followed me home, a 3V regulator was quickly mounted on the meter, and a permanent digital display in the control box was achieved.

❑ **Relays.** Two 12 V DC relays are required: one DPDT and one SPDT.

❑ **Control box and Remote Tuner enclosures.** Your enclosure requirements will depend on the physical size of the components you acquire. My control box, a Hammond enclosure, is comparable in size and similar in appearance to a Ham IV Rotor control. To accommodate my large roller inductor, a scrapped outdoor electrical metering box was used for the tuner.

The remaining bits and pieces (switches, terminal strips, LEDs, etc.) required for the remote control tuner will be apparent from the circuit diagram.

### Circuit Description

The Remote Control Tuner permits three inductor/capacitor configurations, as determined by relays K1 and K2 (Fig. 3). With K1 and K2 de-energized, we have a capacitive input "L" arrangement. Energizing K2 changes this to a capacitive output "L", while energizing only K1 provides a series LC configuration. Rotary switch S1 is used to select the desired configuration, with visual indication being provided by LED's.

Inductance and capacitance adjustment is achieved using the circuit illustrated in Fig. 4. Switch S5 selects either the Capacitor or Inductor for adjustment and position indication. Depressing spring-return switch S2 or S4 will produce clockwise or counterclockwise rotation of the selected device. Switches

S2, S3, and S4 should be flat "piano style" switches, similar to those used in "Ham IV" rotor control boxes, to permit comfortable and responsive control. Note that depressing S3 in conjunction with either S1 or S4 reduces the voltage applied to the motor, thereby providing slow-speed rotation for fine-tuning. You will need to experiment with your particular motors and power supply to determine whether one diode, or several diodes in series, is required across the normally closed contact of S3. (If the voltage drop is too great, the motor will stall). Of course, the current and PIV rating of the diodes used will have to be sufficient for your particular drive motors.

You will note from the circuit diagram that nine conductors are required between the control box and the remote tuner. If only eight are available (because you are using eight-conductor rotor cable or parallel runs of four-conductor cable), the common return line for relays K1 and K2 can piggyback on the shield of the coax feedline. It is important that a choke and shunt capacitor be installed on each conductor entering the remote tuner housing.

The performance of your remote control tuner will of course depend on the particular components that you have been able to acquire. Experimenting with its capabilities will provide many hours of interesting research, and studies by Bob Kellogg [1] on a number of commercially available tuners have provided a benchmark against which your tuner can be compared.

An SWR analyzer is invaluable for initial adjustment of the tuner with a particular antenna. After desired tuner settings (L and C position, and L-C configuration) have been determined and recorded, it is easy to use the control box display to adjust the tuner. Obviously, more exotic schemes using rotary encoders might achieve greater accuracy and consistency. However, the simple analog potentiometer position indication used here has been satisfactory for coarse tuner adjustment. An in-line SWR meter is then used for quick "fine tuning".

As had been anticipated when the project began, my remote control antenna tuner has been called upon to work with a variety of antennas over the past few years. (A slightly different antenna seems to spring up each autumn before the snow flies!). The tuner's versatility has been very much appreciated.

### Operation and Performance

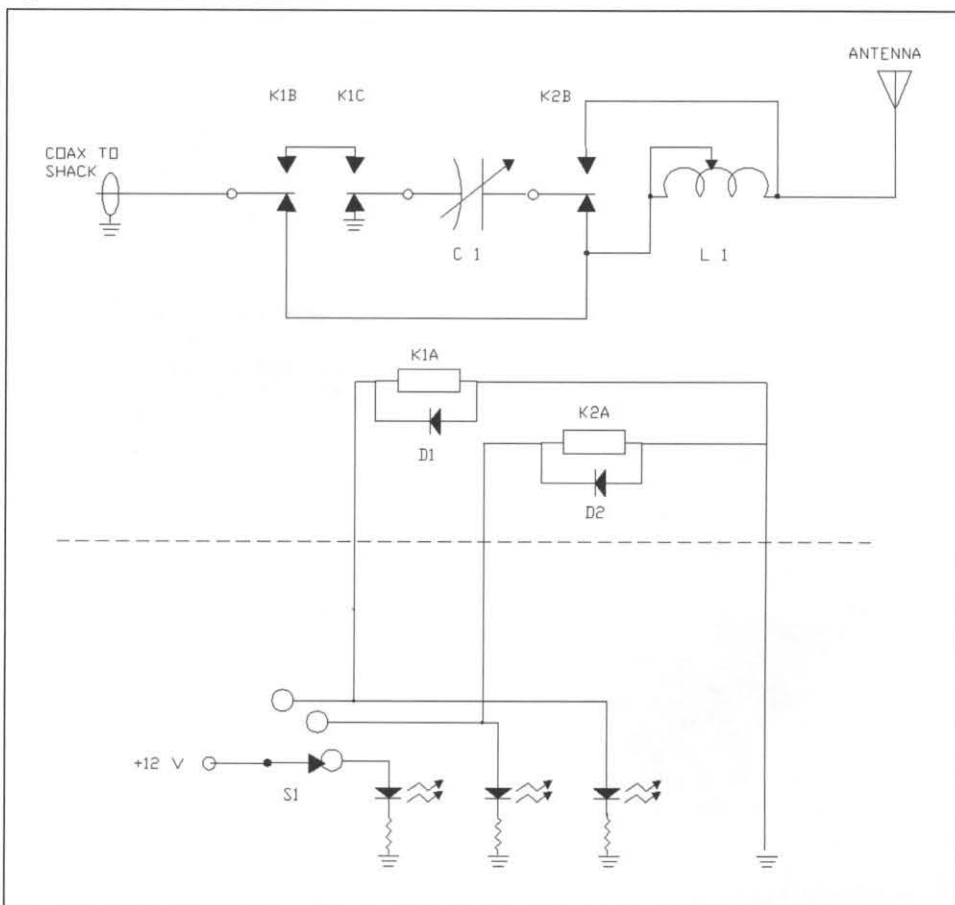

Fig. 3—Motor drive and position indication. Components below the dotted line are located in the control box.

I hope the ideas presented in this article spark your imagination and help you find new life for some lonely junk box components.

### Notes and References

1. Here are some articles for more ideas on remotely controlled tuners:  
 "The 160-Meter Antenna Dilemma," Doug

DeMaw W1FB, *QST* Nov. 1990, pp.30-32  
 "The Inverted L Revisited," John F. Lindholm W1XX, *QST* Jan. 1983, pp. 20-22  
 "A Big Signal from a Small Lot," David Hol-  
 lander N7RK, *QST* April 1979, pp. 32-34  
 "A Remotely Switched, Inverted L Antenna,"  
 Doug DeMaw, *QST* May 1985, pp. 37-39  
 "A Modest 45 Foot DX Vertical ...," Wayne

Sandford Jr. K3EQ, *QST* Sept. '81, pp.27-31  
 2. A summary of Bob's test results can be  
 viewed on-line at: [http://qrp.lehigh.edu/lists/qrp-l/article/ae4ic\\_ant\\_tuner.html](http://qrp.lehigh.edu/lists/qrp-l/article/ae4ic_ant_tuner.html) Bob's test  
 methods are based on a two-part article "How  
 to Evaluate Your Antenna Tuner" by Frank  
 Witt, AI1H, appearing in the April and May  
 1995 issues of *QST*. ●●

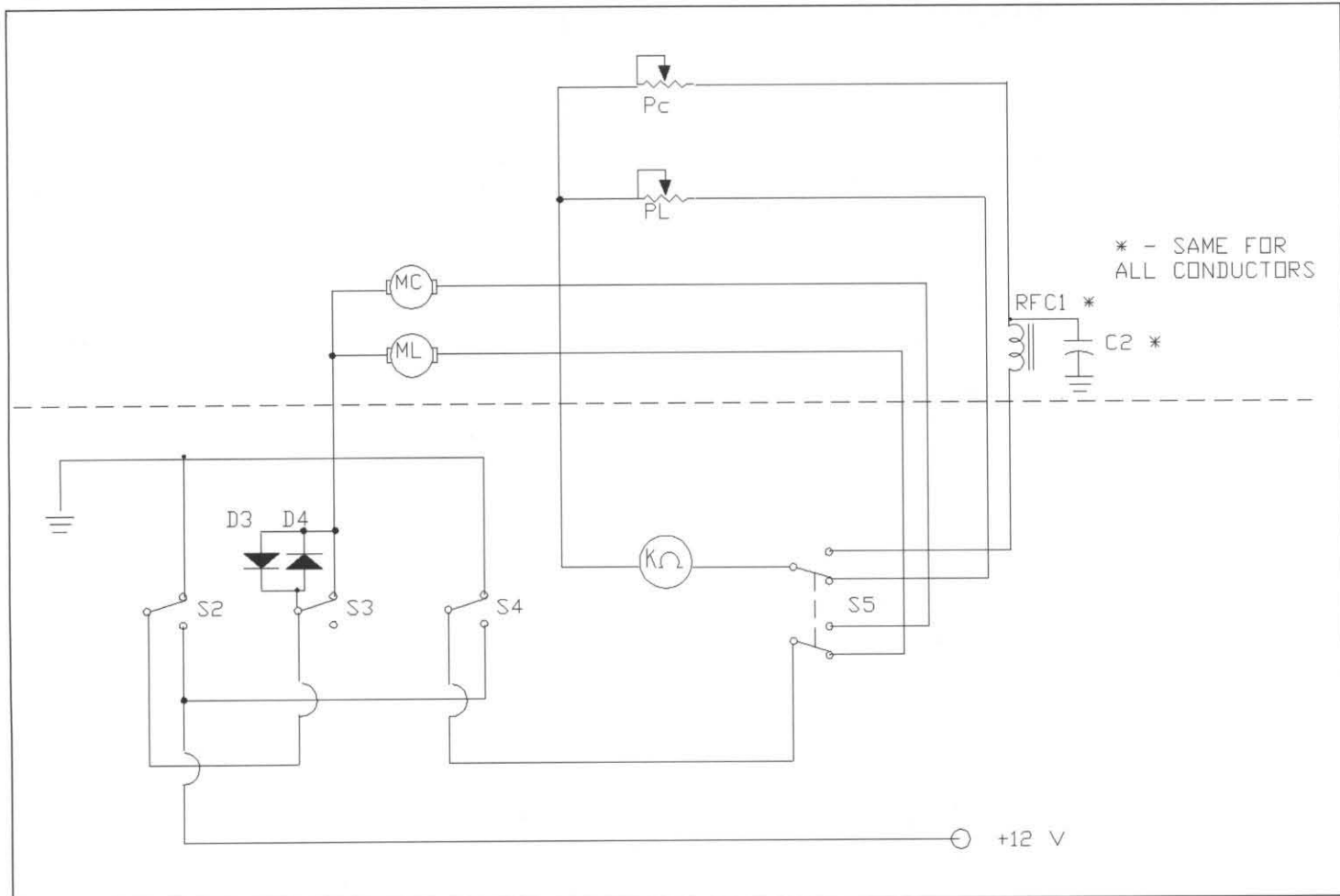
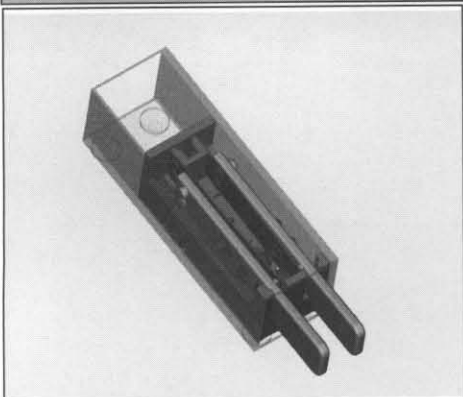

Fig. 4—L-C configuration control. Components below the dotted line are located in the control box.

## New Mini-Paddle Announced

Johannes Hiller—DL9SCO

[hannes@ulmnetz.de](mailto:hannes@ulmnetz.de)



A new portable twin paddle has been designed by two German hams: Dieter—DJ6TE and Hannes—DL9SCO. Lightweight and only 1  
 24 April 01

x 1 x 3 inches in dimension, it fits in practically every pocket. As a real novelty the paddles can be retracted into the rugged aluminum cabinet to protect them during transport.

The cabinet is made from extruded aluminum and powder coated in the same color as the Elecraft-transceivers K1/K2 to match them perfectly.

Three separate adjustment screws allow individual adjustmust of:

- Spring tension
- Contact spacing
- Paddle stop

According to personal preference, a hard  
*The QRP Quarterly*

or soft paddle stop can be chosen. The Mini Paddle is equipped with gold-plated contacts to guarantee longevity and reliability. It comes with a pre-attached cord terminated in a mini-phone plug, and a snap-in mounting plate. The paddle can be snapped into the plate on any side, so the plate can be mounted on the top, bottom, or side of any convenient surface. Optionally, a magnetic version of this mounting plate can be obtained.

For further information, check this WEB address: <http://www.ulmnetz.de/HANNES/Keyer.html> or the US distributor, Morse Express, <http://www.MorseX.com>.

[www.qrparci.org/](http://www.qrparci.org/)

# My Thoughts on the Yaesu FT-817 QRP Transceiver:

## A Product Review

Greg Buchwald—K9QI

greg.buchwald@email.sps.mot.com

About a year ago, rumblings about a new QRP transceiver from Japan began to surface. I asked a ham buddy / work acquaintance of mine in Japan to snoop around and see what he could find. Initially, nothing could be found out about these this new product, but by Dayton time, many of us found out about a new radio from Yaesu that was destined for the Japanese market. We were all hoping that it would also appear in the US market, but it wasn't until early November that this new OEM QRP radio would appear officially in the United States. My need for such a radio became quite apparent last July when I had the opportunity to travel to Namibia for 2 weeks of astronomy. The draw of dark, southern skies was not enough to quell my desire to also take along ham radio of some form. I had been issued the callsign V5/K9QI by the Namibian government and intended to use it!

Looking around in the shack, there were a few options: What to take? I knew for certain that I would take my NorCal 40A, which I had been purchased in kit form from my friend Bob Dyer at Wilderness Radio. Powering that would be easy, and my tape dipole would have to suffice as an antenna. But I also wanted to have 20, 15, and 10 meter capability as well as the SSB mode at my disposal. Anyone traveling overseas – especially to Africa – knows the limitation of 22kg / person (about 50lbs) in the cargo hold. Looking around the shack I saw the IC-736 (just too big to bring), my QRP collection (a HW-8, a 30M SST, and my homebrew 5703 sub-mini tube-based 2W 80, 40, 20, 15M rig), and a TS-50S which I had obtained used from another buddy of mine, K9AM, when he picked up a second hand IC-706. Only the TS-50S was small enough, light enough, and supported SSB. There was not enough time to consider building a K-2 and purchasing anything else didn't make sense. So, the TS-50, a 4.5lb switch mode supply, and the antenna were it. The radios along with telescope eyepieces and accessories started to add up. Factor in clothes – winter clothes since it was going to drop below freezing at night – and I was pushing the luggage budget. How I longed for a lightweight, all-mode radio!

Upon returning to the US after a very successful trip – ham radio and astronomy wise – I soon learned that the FT-817 was getting closer to US introduction. Furthermore, ad-



vance orders were being taken. Knowing that I would be going back to Africa in 2001, I got on the list at AES-Milwaukee immediately. It would still be until the end of November before my radio would appear.

### The Radio Arrives! Initial Reaction and Findings:

One rather dreary night I arrived home, after a long day at work, to find a package on my porch from AES. I think I had the protective shipping box opened even before I got in the door. Nestled inside was the package I had been anticipating for several months; my -817 had arrived! As I opened the box, I was astonished at the small size. I knew the dimensions from web sites and users groups, but 5 ¼ x 8 x 1 ½ inches (approximate size including all protrusions) seemed even small that one would think. How did they cram 160M thru 450MHz with all modes in such a small box? Furthermore, there was room for 8 "AA" batteries in there as well. Incredible!!! – I had to get this thing on the air. My wife had assumed that I would fix dinner that evening since I had arrived home first, but I had more important work to do. I had to get this thing connected to an antenna and try it out!

Minutes later the plastic bag around the radio had been shed, my bench supply was set to 13.8V, and my roof-mounted Mini-33 tri-bander was hooked to this little radio. I tuned around 20M, heard a CQ out of Japan, and answered it. Got a 559! The little bugger re-

ally worked! I then zipped down to 10 and heard a guy in AZ on sideband. It took a couple of calls, but he heard me and we exchanged reports. Finally, I changed antennas. With my 40M dipole now extracting signals from the ether and funneling them into the -817, I tuned around to see what I could hear on my favorite CW band. Up around 7140 in the novice portion of the band, I heard a CQ and gave a quick call back. It turned into a 40 minute QSO with a report of 579 w/QSB. Not bad for 2.5 watts! (I later learned that my radio had been set for 2.5 – not 5 – watts for my previous QSO's of the evening.) My wife walked into the shack and said "What a cute little radio – new toy?" Little did she know just how cool this new radio really was. But it was time to get a bite to eat and crack open the owners manual – that little book that came with radio and which told me how to crank this thing up to 5 watts!

As the initial euphoria of the new radio began to settle, I started to think about the many uses I would have for this little rig. I wondered how sensitive it really was, and if I could add a small amplifier for those days when the band was real bad. I thought maybe a little add-on QRO device to make 20W, 50W, maybe even a full gallon (100 watts in my shack). But before doing so, I would have to know if I would make FCC regulations with this radio in terms of harmonic suppression if an amplifier were added. And, was the third

and fifth order IM performance good enough that I wouldn't splatter and be a bad neighbor on the bands? These questions needed to be answered along with the obvious – how sensitive is this little guy and how bullet-proof is the receiver. Finally, how practical is this radio for the various forms of portable operation which exist in the ham community.

Out of the box, the -817 is a very impressive rig. It supports all mode operation on all HF bands plus 6M, 2M, and UHF. It also has AM and WBFM coverage (so that you can listen to the game, weather, news or music) as well as aircraft band AM reception. It also has limited extended VHF coverage, but more on that later. The -817 has 9 modes: Packet (1200 or 9600 baud are supported), Digital (for PSK-31, RTTY, etc), CW, CW-R (reverse BFO injection), USB, LSB, AM, FM and FM-N (narrow deviation FM for use in crowded spectrum locations such as in Europe). The extended menu allows you to choose the sideband when in the digital mode, the type of modulation (either mike audio in, de-emphasized audio out for 1200 packet / APRS or direct FM / discriminator audio for 9600 packets), separate menu-driven audio gain controls for mike, digital, and packet modes, PL / DPL encode / decode for repeater use, programmable repeater offset by band, a build-in CW keyer, a crude, but effective internal charger for the battery pack, full cross-band and split operation, RIT (termed "clairfier" by Yaesu – a bit too CB-like for me), passband shift, and lots more including switch-able backlighting (orange or cool blue.) Power can be programmed for 5W max CW / 5W PEP SSB, or down to 2.5, 1, or 0.5W. When using the internal battery supply, 2.5W is automatically selected. You can force 5W operation from batteries, but the power level indicator will flash to tell you of this condition. If you are lucky, you will make it thru a few QSO's in this mode! Finally, the display can be programmed to indicate current battery voltage to keep track of the condition of the batteries. For those that are concerned over reading the small, but packed LCD display, there is a second display mode which can be chosen. In the alternative display mode, the numbers appear much larger and are easier to read. An hour or so should be set aside with the radio and manual to fully learn its capabilities.

### Data Collection / Test Set-up

The FT-817 was fitted with Maha 1600mAH cells, which were fully charged external to the radio. In normal operation, I charge the batteries in the radio. This can be

---

*...new toy?" Little did she know just how cool this new radio really was.*

---

done by performing a small modification to the AA battery holder – cutting the green lead, folding it back on itself, and securing it with a small piece of shrink wrap. The green wire tells the radio that non-rechargeable batteries are installed, rather than the specified, optional battery pack from Yaesu. When this line is cut, the internal charger will become operational. I find that 10 hours at 220mA is sufficient to charge the pack. After the charge is complete, a small trickle charge takes over. This, and other mods, can be found posted on the eGroups FT-817 website. This is the only mod which I have made to my radio. Note, however, that the charger is "dumb". It simply turns on a current source for 6, 8 or 10 hours, depending upon what you program into the radio. You can overcharge your batteries if you don't keep track of your batteries and their current charge level. The best solution is to use an external charger – the internal system is, however, the most expedient!

During RX testing a recently calibrated HP 8640 generator was used. The audio is taken from the headphone jack, with the internal speaker disabled via the convenient switch on the side of the -817. A Tektronix AA501 audio test set is used to analyze the resultant audio. MDS was also verified on headphones (Sony MDR-V1) and is qualitative using my own ears (the number that really counts for me!) Blocking and IP3 measurements were made using a second HP8640 generator and a homebrew two-port combiner.

Transmitter tests were performed utilizing the Tektronix SG505 audio test set for tone #1 (1000 Hz) and a second Tektronix SG505 audio test set for tone #2 (1200 Hz). I used these tones as I feel they are a good compromise between understanding the performance of the radio under voiced operation as opposed to digital (RTTY, PSK-31, etc.) or SSTV modes. The tones were summed using an ATI LT-1000 distribution amplifier, common in the broadcast industry. This device could be adjusted in output level to produce the desired RF power level. A series combination pad, consisting of a Narda 20dB, 20W pad, and a Narda 10dB, 20W pad was used to terminate the radio and feed a Rhode and Schwartz FSEM-30 RF spectrum analyzer. Two-tone PEP power levels were calculated based on envelope measurements made on a Tektronix 2445B oscilloscope. In this case, a single, 20dB Narda pad feed the oscilloscope, which was terminated at 50 Ohms. CW power level

*The QRP Quarterly*

calculations were made in the same way.

### Discussion of Results:

It can be clearly seen that the rig is a good performer. Harmonic suppression and IMD performance are suited for higher power operation, should it ever be contemplated. Harmonic and spurious content can be seen in **Figures 1 and 2** representing operation with the external supply at 5 watts (CW) and the internal supply at 2.5 watts, respectively. Though the two-tone IMD spectrum is not quite as good as one would expect from some higher powered rigs, one must keep in mind the absolute power level of these spurs. Furthermore, the PA devices are utilized from 160M through UHF. **Figures 5, 6 and 7** indicate the single tone reference level for USB operation at 5 watts CW, two-tone IMD at 5 watts PEP using the external supply, and two-tone IMD using the internal battery supply at 2.5 watts PEP respectively. In the case of **Figure 5**, the display is centered on the carrier frequency. In **Figures 6 and 7**, the display is centered between the two tones.

A modest external amplifier can be added without fear of splatter or citation provided it has good performance. I actually used the FT-817 to drive my old Central Electronics 600L. This amplifier produces about 50W output power when fed with 5W input. It is a lot of iron to make 10dB of power gain, but it is a good use for that old beast that was otherwise gathering dust! Using an 813 to make 50W seems like overkill, but it sure is linear and, I think, Wes Schum would be proud!

On the receive side, the Collins mechanical filter, or an after-market crystal filter, is, in my mind, a requirement for CW operation. But that can be said for nearly any rig. While the pre-amp and input IMD / blocking specs are not as good as one might find on the best high-end full-sized shack rig, this radio is no slouch. It might not perform as good as a FT1000D at a big, multi-op field day site, but the performance is more than adequate for the use for which this rig was intended.

Is there a downside? The answer is yes, maybe a few.... The current consumption is quite a bit higher on receive as compared to some of the other QRP rigs out there. The specs indicate that approximately 250mA is the minimum drain in the RX mode, but I was not able to achieve this using an external supply. I did not measure the drain from the internal battery pack – perhaps this figure can be met using the optional 9.6V pack. If your only goal is to take the rig backpacking, for

[www.qrparci.org/](http://www.qrparci.org/)

## Tests Performed and Results:

**Transmitter--Data taken on 20M (14.050 for CW, 14.200 for SSB). All HF bands were similar in performance.**

Two-tone IM – B <sup>1</sup>	3 <sup>rd</sup> order –26/30dB, 5 <sup>th</sup> order –40/45dB <sup>5</sup>
Two-tone IM – E <sup>2</sup>	3 <sup>rd</sup> order –28/35dB, 5 <sup>th</sup> order –42/44dB
Harmonic Suppression – B	2 <sup>nd</sup> –70dBc, 3 <sup>rd</sup> –62dBc, higher <-73dBc <sup>4</sup>
Harmonic Suppression – E	2 <sup>nd</sup> –76dBc, 3 <sup>rd</sup> –62dBc, higher <-73dBc
Keyed CW Waveform	Exponential Rise; no discernable key clicks.
Carrier Suppression SSB – E	-53dB (ref. To 5W carrier)
Undesired Sideband Suppression – E <-46dB (300 – 2700Hz) <sup>3</sup>	
Power Output, CW 5W mode – E	4.78 watts
Power Output, CW 2.5W mode – E	2.73 watts
Power Output, CW 1W mode – E	0.96 watts
Power Output, CW 500mW mode – E	0.68 watts

### Notes:

- 1) B designates Battery operation, 2.5W CW / PEP
- 2) E designated External AC supply, 13.8VDC at 5W CW / PEP
- 3) 1000 Hz tone –57dB, 1200Hz tone –59dB
- 4) Additional spurs present, none greater than –73dBc
- 5) IMD products were not symmetrical as can be seen in Figures 6 and 7.

### Receiver:

Sensitivity – SSB (12dB SINAD):	0.19uV
Sensitivity – CW (7dB SINAD) w/500Hz filter:	0.07uV
MDS – CW (with optional 500Hz filter):	-136dBm
MDS – SSB (w/internal 2.7kHz filter):	-128dBm
IP3 w/o pre-amp:	+2.5dBm
Image rejection:	74dB
Selectivity w/internal filter:	2.27kHz, -6dB; 4.45kHz, -60dB
Selectivity w/500Hz. Collins filter:	488Hz, -6dB; 1.95kHz, -60dB

### Overall Specs (External 13.8 Volt supply):

Current Drain, RX fully active radio:	380mA
Current Drain, RX, back light off:	348mA
Current Drain, RX backlight off, squelched audio:	338mA
Current Drain, as above, batteries removed:	325mA
Current Drain, TX CW 5W	1.92 A
Current Drain, TX CW 2.5W	1.62A
Current Drain, TX CW 1W	1.17A
Current Drain, TX CW 0.5W	1.05A
Current Drain, TX SSB, 2 tone, 5W PEP:	1.26A

days on end, with no external supply, then you may opt for a K2, K1, Sierra, or one of the other QRP rigs that are out there in kit form. On the other hand, if you are like me, the rig will get used at home, perhaps at field day hooked to an external battery, and it will go with me on trip – especially overseas –

[www.qrparci.org/](http://www.qrparci.org/)

where power is available but luggage space is not! This rig is tailor made for that type of application.

A second potential negative is the “extended” VHF receive range. I had hoped that the US version would receive up to 162.55MHz so that I could also listen to

NOAA weather broadcasts with the –817. Reception ends at 154MHz, making NOAA reception impossible. But it does have extended WBFM coverage from 76 – 108MHz which cover all FM broadcasting world wide including Japan, but excluding old broadcast facilities in Eastern Europe. Besides, if I had to choose between NOAA coverage or better IM protection for 2M, I would take the latter.

A possible third minor issue is FM audio quality using the handheld mike that comes with the rig. More on this a bit later.

Fourth, my spectral measurements did pick up spurs at the sidetone frequency when operating CW. These spurs were down about 42dB, but did track the sidetone frequency. Operating at 5W, each tone represents about 0.5mW – nothing to be concerned about – but it does indicate that there is some coupling of the supply drain to the VCO or, more likely, the synthesizer error control voltage. **Figure-3** indicates the spurs present when the sidetone frequency is 350Hz, while **Figure 4** indicates the spurs when the sidetone frequency is 700Hz.

Finally, while this rig is not being marketed as an all band / all mode like other rigs out there, I am nonetheless disappointed that it does not support 222MHz TX and RX. While the lack of the 1.25M band in this radio does not bother me as much as its conspicuous absence in other products such as the FT-100, IC-706IIG, and the new TS-2000 (which is being marketed as all band / all mode), I am nonetheless unhappy about the snubbing of this primary allocation band in our market by offshore manufacturers.

### Further Findings, Thoughts, and Reactions:

My –817 travels with me in briefcase, along with a 3A RadioShack switchmode power supply which operates from 90 – 240 VAC mains. I have heard that some comments that the RS power supplies can be noisy, but mine seems just fine. I have an old Motorola tape dipole antenna, which I also take with me on some occasions. It is nearly as heavy and as big as the FT-817, but it goes in the luggage. Obviously, there are lighter antennas which one can use, but this is a no-brainer, easy to pack set-up for me. As an alternative, I recently purchased and built an LDG Z-11 tuner, which is about as big, but lighter than the tape antenna. With the Z-11, I simply use a long wire strung up anywhere I can put it. There are even lighter, manual tuners out there, but I find the LDG tuner to be well worthwhile.

A bonus in this rig is the 6M, 2M, and 440MHz operation, also all-mode, which the -817 provides. I have, on several occasions used the -817 mobile, with a mag-mount antenna to work the local repeaters. I also tried it on my own 6M machine in Crystal Lake, IL. The comments I got back were quite good except for the ever-discerning ears of my friend Jim - WB8HMD. Being quite familiar with the fine, compandored audio produced by the Motorola FM rigs that we usually use in our cars, he commented that the FM audio was a bit hollow sounding. The mike has a switch on the back to tailor the audio a bit, and he suggested that position 2 sounded "more like me." On the other hand, I found the rig to have more punch on SSB when in position 1. I wonder how the rig would sound with a Heil headset!!!?

Reactions from others have been also quite good. I took the -817 to our annual holiday dinner meeting for the Motorola Amateur Radio Club. Everyone that saw the radio and tried it was impressed. Our club president, N9KNS, and many others, could not believe it was all mode / all band thru UHF (except for 220 as noted above). Even our resident high power, "Life is too short for QRP" club station trustee - Don, K9UQN - thought the rig was really pretty neat. He has since worked several people using them from Ohio to Japan. While the -817 might not be enough to suppress his hunger for power, I would not be surprised if one does not end up in his shack as well!

It is my hope to supplement this report with a short article on the VHF and UHF performance of the -817. I have been waiting patiently for a good 6M and opening, but, sad to say, 6 has been pretty dead in 9-land. Stay tuned - more to come on this little rig's V/U performance. I also hope to report on the PSK-31 performance of the rig.

The FT-817 can truly serve triple duty: In the shack, in the car, and as a portable. I am very pleased with the quality of the radio, the packaging, the ease of controls for the most part, and the performance. And I can live with the current consumption knowing that it takes that level of current to support the small-step synthesizer, front-end and control circuits found in this quality of radio. In fact, I enjoy this rig so much in the shack that I may need to find another for road trips! Anybody wanna buy a used TS-50? Seriously, I hope that this fine, new radio product from Yaesu spurs growth in QRP operation and additional new products in the QRP OEM marketplace. It has been a long time coming. ●●

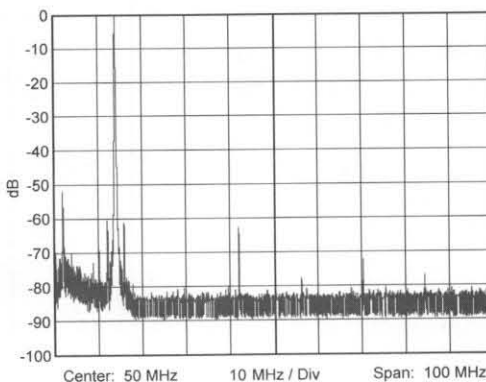

**Fig. 1—Harmonic / Spurious Response, 14.050Mhz, 5Watt, External Supply**

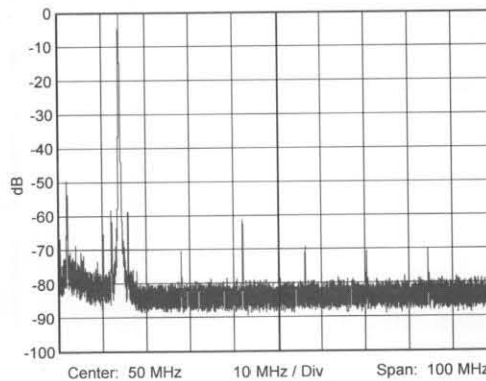

**Fig. 2—Harmonic / Spurious Response, 14.050MHz., 2.5 Watt, Internal Batteries**

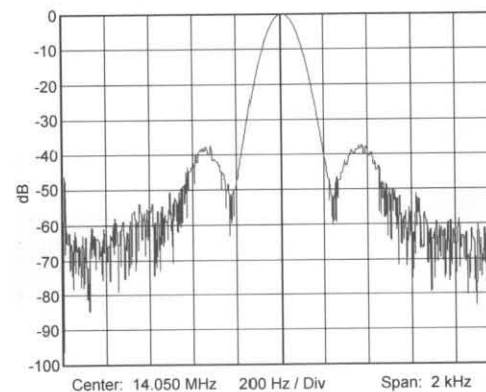

**Fig. 3—CW 350 Hz. Sidetone-induced Spurs, 14.050MHz., 5Watt, Ext. Supply**

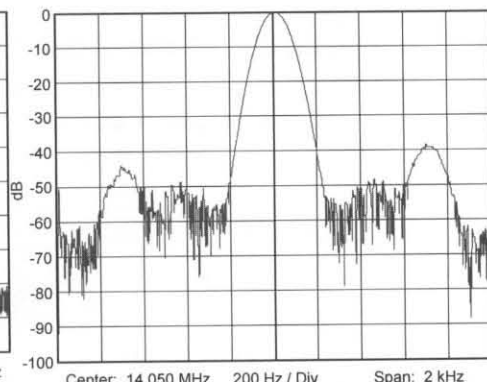

**Fig. 4—CW 700 Hz. Sidetone-induced Spurs, 14.050MHz., 5Watt, Ext. Supply**

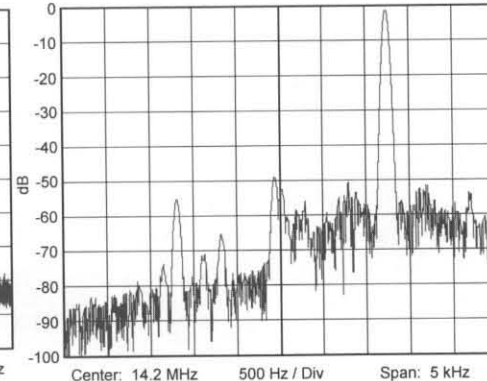

**Fig. 5—Single Tone (1000Hz) RF Spectrum, USB, 14.200Mhz, 5 Watts CW.**

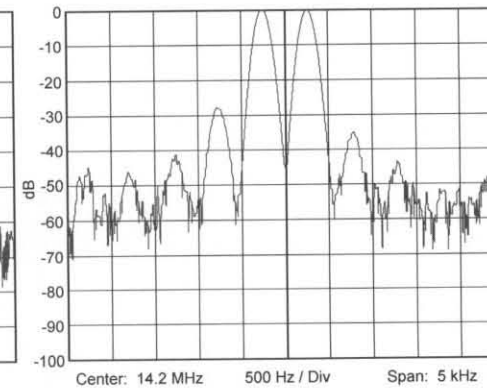

**Fig. 6—Two-tone (1000 / 1700 Hz) IMD, 14.200MHz, 5 Watts PER, Ext. Supply**

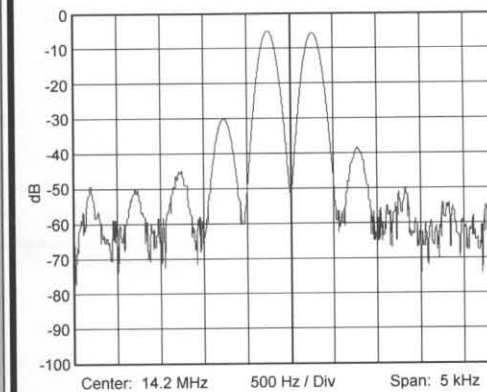

**Fig. 7—Two-tone (1000 / 1700 Hz) IMD, 14.200MHz, 2.5 Watts PER, Int.**

**A Special thanks goes to  
Greg Buchwald—K9QI for  
providing this engaging and  
useful new product review.**

**This is a great example of how  
a review should be done for  
the QRP Quarterly. (ed.)**

# Some Comments on Powering the Yaesu FT-817

Barry Johnson—W4WB

w4wb@oetc.com

The newly introduced Yaesu FT-817 can be powered using either the internal batteries or an external DC supply. Various choices can be made for the batteries and the external DC supply. In this article, several alternatives for the sources are presented.

The FT-817 specifies that the external power source should be 13.8 VDC  $\pm$  15% with a continuous-duty current capability of 3 A. The operating range is 8.0 to 16.0 V. It comes with an internal battery holder (FBA-28) that holds 8 AA alkaline cells (12 V). Yaesu also offers an optional NiCd battery pack (FNB-72) that provides 9.2 V with a 1000 mAh capacity and costs \$59. The current-consumption specification during receive is 450 mA and 2.0 A during transmit. Consequently, the life of the alkaline batteries is rather short, and useful primarily for those "just have to operate" moments.

Alternatives to using alkaline cells in the supplied battery holder, despite Yaesu's statement to the contrary, are to fill the AA holder with NiCd or NiMH AA cells. They can be charged using the internal charging circuit that provides about 180mA (18 mA trickle). The charging time should be selected (Menu #11) for 10-hour charging time. Depending upon the capacity of the batteries, you may have to charge for more time; however you are cautioned to install a fuse, such as a 3 A picofuse, at the battery pack. (Beware your warranty of course.) The cable from the FT-817 to the FBA-28 battery holder contains three wires, one being green. The green wire needs to be connected to the FBA-28 when alkaline batteries are being used. Should you put NiCd or NiMH cells in the FBA-28 battery holder, then disconnect the green wire from the battery pack. The wire can be cut (and taped) or, if you are concerned about restoring the unit for alkaline batteries (or simply don't want to cut the wire), the green wire may be removed by poking a safety pin (or the like) into the connector to release the clip that holds the pin or socket connection in the white plug or socket body. Slide out the wire with the tiny connection intact, tape it out of the way and you can reseal it when desired. When the FT-817 is powered from a 13.8V power supply, the FT-817 will charge the batteries for the time set in the BATT-CHG menu option and then drop to trickle charge. Using the modified FBA-28 also allows you to swap out the batteries when ex-

hausted and replace with a fresh set while charging the others in an external charger.

## Battery Pack and associated connectors.

Another interesting approach is to replace either the FBA-28 or FNB-72 with a commercial battery pack such as the Model 23-331B by Radio Shack (RS) that was intended for radio controlled vehicles. This \$25 NiMH battery-pack provides 9.6 V with a capacity of 1600 mAh and it fits perfectly into the battery compartment of the FT-817. A transition cable can be made to minimize the amount of wear and tear on the FT-817 internal power connector. One approach is to replace the rather large connector on the RS battery pack with a smaller connector such as the Molex plug (part no. 03-06-2024 with terminals 02-06-2103) with a 3-A pico-fuse in each leg. Next make the transition cable using a Molex receptacle (part no. 03-06-1022 with terminals 02-06-2103) and a female Molex connector (part no. 51021-0500 with terminals 50058-8100) that mates with the male Molex connector (part no. 51047-0500 with pins 50125-8000) going to the PCB of the FT-817. Alternatively, the wiring harness can be taken from the Yaesu supplied battery holder and wired to the 51021-0500 Molex connector. Be sure to connect both red wires together and both black wires together, and do not connect the green wire to anything. The "ears" on the larger Molex connector need to be cut off for proper fit in the battery compartment. As can be seen in **Figure-1**, the wires dress nicely and the battery pack fit is comfortable and stable. It is generally suggested that the battery pack be cycled

three times before performing partial recharges.

When using the FT-817 in your shack, almost any good linear or switching power supply will work fine as long as it meets the specifications above. Although switching power supplies can produce annoying interference on your radio, many are very RF quiet. The FT-817 just begs to be taken on trips and outings more than a good dog. If you are going to be somewhere having an AC facility, then, if you are like I am, you will want to have a small, lightweight power supply to take with you. There are a number of such switching-type power supplies available. One relatively inexpensive and readily-available power supply is the Radio Shack regulated power supply having part no. 22-503. Regular price is \$50 and has been on sale for \$40. This unit operates from input voltages from 90 to 240 VAC and input frequencies of 50-60 Hz. Its output is 13.8 V  $\pm$  5% at 3 A continuous duty and provides AC-fault and short-circuit protection. The line regulation is less than 5% with a maximum output ripple of 100 mV rms. The 22-503 weighs 14.25 oz (400 g) and has dimensions of 1.9 x 3.0 x 7.5 inches (48 x 76 x 191 mm). Output power connection is made using either a cigarette-lighter socket or the spring-tab type connector. No output cable is provided. As previously mentioned, a switching power supply can create noise in your rig. This particular power supply from Radio Shack has a mixed history. Some work just fine and others are noisy. If you decide that you want one, it would be prudent to take your rig to the store and try out different units until a quiet one is found.

Recently, International Power Sources introduced a new line of ultra-miniature desktop power supplies with universal input (90-264VAC). The unit that is appropriate for the FT-817 is the Model CUP36-12-1 switching power supply. It is rated at 13.5 V  $\pm$  4%, 2.4 A, 36 W continuous duty, and has an 85% efficiency. The maximum output ripple and noise is 1% peak-to-peak (approximately 23 mV rms). The CUP36-12-1 is provided in a non-vented polyphenylene oxide case only 4.3 x 2 x 0.8 inches (20 x 50 x 110 mm) and weighs less than 6 oz (170 g). Included is a strain-relieved, six-foot shielded output cable with a standard barrel-type connector that must be replaced with a coax-style plug hav-

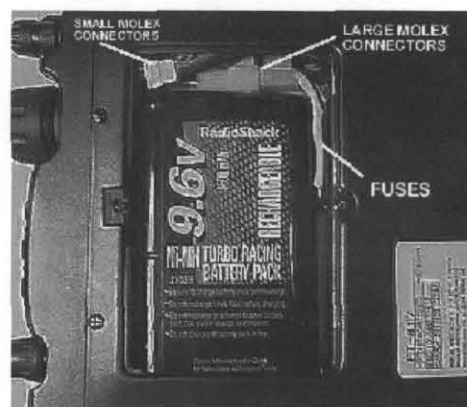

**Fig. 1—Placement of the Radio Shack 1600 mAh, 9.6 V NiMH Battery Pack and associated connectors.**

*The QRP Quarterly*

ing dimensions of 4.0 x 1.7 mm such as the Radio Shack part no. 274-1532. Full-power operation from 0 to 40°C is allowed in virtually any inside environment. Input to output isolation is 3000 VAC. Approvals have been received from UL, CSA, CE and TÜV, and it meets EMI limits per FCC and CISPR. Output voltage accuracy is better than 2% at full line, load and temperature range. To enhance reliability, the CUP36-12-1 is burned-in fully-loaded. The stated MTBF is 100,000 hours. Protection is provided for overvoltage, short circuit and input surge. Remarkably, the single quantity price is \$32.90. My experiments with this power supply have shown it to work great with the FT-817 under all modes at full power. Measured peak-to-peak noise plus ripple was 40 mV at one ampere. No noise from the CUP36-12-1 was detected by the FT-817. Using a HP spectrum analyzer, the RF emission was observed to be minimal. This unit is now the sole AC power supply for my FT-817. **Figure-2** presents a visual comparison of the relative sizes of these two power supplies and the FT-817.

It should be mentioned that the FT-817 does not have 100% protection for that time when Mr. Murphy (of Murphy's Law fame) helps you to place the negative wire from the FT-817 on the positive side of the battery and



**Fig. 2—The FT-817 is shown with the Model 22-503 and the CUP36-12-1 power supplies.**

the positive on the negative side. Examination of the circuit diagram indicates that there will be some smoke if this happens. Remember that whenever something loses its smoke, it's dead! An inexpensive way to protect the FT-817 from this type of "operator error" and from overvoltage glitches is to place a 2.5-A fuse in-line with the positive wire and install a Zener diode (such as 1N4745 or RS 276-564 ) across the power leads. The fuse goes between the diode and the power source (external battery or power supply). The cathode should be connected to the POSITIVE wire and the anode to the NEGATIVE wire. Be sure to test this setup BEFORE you plug the power cable into the FT-817. If the measured voltage at the power source and the output of the power cable are not the same, you need to

replace the diode with a good one. Reverse the leads and verify that the fuse blows. (Sadly, first smoke cause by unprotected lead reversal was recently reported on eHam.com.)

As mentioned above, the coax-style power connector going to the FT-817 has dimensions of 4.0 x 1.7 mm (not stated in the Operating Manual for the FT-817). Beware of trying to use a connector with dimensions of 4.5 x 1.5 mm although it may appear to snugly fit. The power plug of the FT-817 is not the most durable plug seen, so be careful not to try to force the wrong size plug into the jack. Some reports of the plug breaking off have been reported.

**The International Power Sources CUP36-12-1 power supply certainly has fulfilled my quest for a remarkably small and lightweight power supply that I can take literally anywhere in the world while providing excellent operational performance. International Power Sources can be contacted through [www.intlpower.com](http://www.intlpower.com).**

The contributions to this article by **W3PM** and **W4JZ** are gratefully acknowledged. The information contained in this article is believed to be accurate; however, readers beware and use this information solely at your own risk and liability. ●●

## QRP Club House

Les Shattuck—K4NK

k4nk@arrl.org

Hello again...another issue of the QRP Club-house where we let the clubs have a say about what activities they have going on. This issue should be out just before the Dayton ham fest and FDIM. If you have not attended FDIM (Four Days in May) the events around the great Dayton Ham Fest you owe it to your self to go just one time. You will have the time of your life and get to meet all those QRPer who you've worked on the air. There are so many great speakers and programs you just won't know which program to attend. And don't forget the official QRP ARCI banquet. Each night has additional events and the vendor's night is my favorite. Yes...I saw a K-2 months before they were released, where you say, at vendors night at the motel where ARCI holds the FDIM. OK...got you worked up? Want more info go to the ARCI web page.

Lets see who else sent in info this issue. Here's a note from John WB1HBE the news coordinator for the New England QRP Club. John says a annual meeting will be held at 9 am on 31 march 2001. It will be held at ARRL

headquarters in Newington, Ct.. After the meeting a luncheon at a local restaurant is planned... And...yes they will be operating QRP from W1AW. John also tells us that the club net is held at 9pm on Thursday evenings winter months it seems that 3.561 is best and the NCS call is WQ1RP their club call.

OK now another e-mail from W8PIG. That would be none other than the Flying Pigs QRP Club. I am proud to say I'm piggy number 25. There website is [www.fpqr.com](http://www.fpqr.com) and they have no dues membership is open to all. The newsletter "Bacon Bits" is available on their web page. Let see...Oh yes the FPQRP club has those great Truffle hunts one-half hour before the qrp-l fox hunt on 7.044. And a net on Mondays and Thursdays at 02:00z 7.044. The current club project is the MP-20 a twenty-meter QRP rig. Check them out.

As you can see by this short column very little news was sent to me, this is your column I report your club info. Please send stuff in to me so I don't have to make up lies. Hi!

*The QRP Quarterly*

Oh...here's one the NETXQRP. What's that stand for? The North Texas QRP Club, and they want every one to know about their meetings. Contact Chuck Carpenter W5USJ or check out the web site. [www.anglefire.com/tx4/netxqrpclub](http://www.anglefire.com/tx4/netxqrpclub).

Just a couple of more things The KLQRP gang will be at the Charlotte, N.C. Ham Fest in force. Although it will be over with by the time you read this, I will be there and report just how much fun we had. Also next issue will be picture issue how about sending me a photo of your club at an event or a favorite watering hole. I bet a lot of our readers would like to see what a great time you club members are having.

Well if you want to contact me—that's easy...[k4nk@aol.com](mailto:k4nk@aol.com) or [k4nk@arrl.org](mailto:k4nk@arrl.org). My name and address is in every QST just look under Directors, Roanoke Division. ●●



# Ramblings of a Peaux Displaced Cajun Lad in Maine

Joel Denison—KE1LA

hamjoel@juno.com



High Y'all... Kinda cold outside an't it? U kneaux we just had a big storm up heah in Maine... Sneaux, sleet, wind... what a mess... even my ant got knocked down... I guess the rope got frayed against the trees and gave way...

What that means is I gotta go out and put another rope in a couple of trees and pull the ant back up...so I is gonna be right back... ok?

High again y'all let me told u how my ant project done went... When I got myself outside in the ice and sneaux I notice the ant had dropped over my house service line (insulated AC line coming into the house) so I put on my rubber gloves and some rubber boots, just in case.

I started pulling the ant wire down and I musta left a sharp spot on one of the hundred of splices and it dug into the AC line as it went over it... no problem as I was prepared for this and when a section of ant went up in smoke... No harm was done... except to the wire of course.

I spliced on a new section of wire and proceeded to throw the steel weight tied on the fishing line over the tree.... no problem,

--continued from page 21--

letters. When conditions are rough, send your call sign in lower-case letters at least four to five times.

**3.** Even on PSK, use phonetics in poor conditions. Typing "Whiskey Three Hotel Foxtrot" is more likely to get through reliably than repeating W3HF six times.

**4.** Use the panoramic display and multi-channel capabilities of the PSK software to watch the whole sub-band. Monitor multiple QSOs, looking for the DX stations. Look for the weak signals, and figure out who they are. It's easier to work them if you find them before the "big guns." That's how I got CN8KD. Everyone was queuing up for 7X4DR, and I [www.qrparci.org/](http://www.qrparci.org/)

as I got it right where I wanted it on about the tenth try. This left me with one tree left to untangle the rope and get the ant back up.

However, on my way down the driveway, while I was admiring the view of the sneaux covered mountains in the distance, I suddenly saw my foots up at eyeball level! Realizing what had taken place and planning a landing I was interrupted by a thud as my back hit the sneaux and ice and ground... my foots were still way up in the air. Laying still a minute and checking out my moving parts I figured I was ok so I sat up... then I heard him... this fella driving down the street done seen me fall and seeing as I was ok he began laughing and lost control of his car and came spinning up my driveway...

He stopped about ten foots from me and was still laughing... not wanting to be a spoiled sport I chuckled at the whole thing and asked him to help me with my last antenna rope... at which point he said sumthin about "crazy hams"... I called my Cajun Mama as told her to bring her double barrel shootin gun... u shoulda seen that fella spin outta thair! Even heard him still laughing as he crested the hill about half a mile down the road.

I went to the last tree and began pulling on the rope... this snapped a fairly large branch which went through the roof of the house and took residence on the second floor... which was no big deal really... that three foot piece of branch what fell and broke my nose was of meaux concern to me. My Cajun Mama stuffed some sneaux up my nose and told me to finish my project and she would call the carpenter for the roof... show is nice to have a good Cajun Mama around the house...

I finally got the ant back up and by now

was first to notice the other station a few hundred Hertz away. Of course I left one channel on the 7X, and went right back there!

**5.** Keep the initial exchange part of the QSO short. PSK is frequently used as a rag-chewing mode, but the QRP station who is 559 is more prone to getting lost in QSB than the big guy at 20-over-9. Get the important info across quickly, and then rag-chew if the DX station wants, but only once the QSO is "in the log."

**6.** Most PSK stations run about 30-60 watts. With my QRP signal, I must always remember that the DX station will hear me at least two S-units lower than I hear them. If the DX is not at least a few S-units above the

*The QRP Quarterly*

the 'lectric company and carpenter were thair and doing their thing... so I pushed the twinlead lead-in wire through the window and went inside the house... course being warm inside, my sneaux packing melted and my nose started bleeding again... however my Cajun Mama stuffed some charmin up the thing and stopped the blood flow...

I got out my soldering gun and tinted the end of the twin lead soes I could connect it to my ant tuner... the wire was still kinda cold and wanted to coil up so I had to keep some pressure on it while I soldered it... now wouldn't u kneaux... the wire slipped outta my hand and flung solder up and into my radio, lettin out a good bit of smoke before the fuse blew. And the twin lead snapped back and flung the tinted ends into the AC wall socket...

At this point I could hear the 'lectric company men yelling sumthin awful and the carpenter was jumping off the second story roof into the sneaux.... I looked outside just in time to see my ant wire glowing and when I looked back my TV twin lead was smoking and turning black... then the circuit breaker blew and things quietened down.

The power company folk won't work at my house anymore unless I sit outside where they can see me and my carpenter insists I take down any antennas I have before he'll fix the hole in the roof... and that is what got me interested in indoor antennas ... let me told u 'bout...

Bye now, y'all be good, KE1LA, Joel in Maine—Mainely freezin' ●●

noise, then I don't even waste time trying to call.

So what's next? Well, there are about 30 other DXCC entities that I've heard but not worked, including ES7AM, TA7I, J28NH, a UN7, TR8CX, an FR5, and A92GE. I used to think I'd buy a 20 W linear to put me more on par with the guys running the barefoot transceivers, but I'm beginning to think DXCC QRP might be possible, even with my antenna constraints; so I'll hold off boosting power. And then there still are those five more states I need for WAS. These past three months as a DX hound have really renewed my interest in ham radio! ●●

# PSK31 "Across the Pond"

Dick Pascoe—G0BPS

rufty@supanet.com



As you may have guessed, that wonderful new data mode PSK31 is taking Europe by storm, just as it has been doing in the USA.

In fact, as some of you may know, PSK31 has part of its original roots in Europe and another part in some of the data modes of the past. In its most simplistic terms CW is a data mode. As we all know, it is made up of a series of 'on-off' tones. The length and spacing of these tones give us the well-known characters we know and (most of us) love. Various other data modes have been used over the years. I even had a British Creed 444 teleprinter on my desk in my early days. A huge beast that rattled away as it spewed out a stream of paper with the text upon it.

Some year's later, computers blossomed and quickly found their way into the shack of most amateurs. Much as radio equipment evolves, most of these computers slowly evolved and changed into the standard PC types we know now. The great thing about this standardization was the amount of software being written for these computers that rapidly appeared. The old teleprinter was discarded and eventually buried in the garden as part of the ground plane of an antenna. RTTY could now be decoded on the computer instead of a box built especially to do the job. It would be a while before anyone would consider writing computer software to replace RTTY but when the first programs appeared,

the effect was like a London bus. You wait for hours and then several come along all at once.

Not only do we have RTTY at this point, but Pactor, Hellschreiber, MFSK, and various types of PSK and many, many more.

Last year, I decided to give PSK31 a try myself. I had never even seen this mode before December of last year, but after much persuasion by Sheldon Hands, MW0ELR, I ventured forth. I learned that this mode was great fun and that, while there were commonalities with US operations, we in Europe had put our own stamp on this new toy.

## Some things are about the same

Here in Europe, many of our operating practices are similar to those in North America.

Most notably, the frequencies used for PSK31 are quite similar except where regional changes in frequency allocations force a change. As the sidebar shows, 40-meter usage is particularly different. And, on 15-meters, most activity can be found slightly lower in frequency than is the case for North America.

We use much the same software as you, but we do have some of our own. A guide of the software can be found at <http://aintel.bi.ehu.es/psk31.html>. I can highly recommend *DigiPan*. Written by KH6TY, with UT2UZ and UU9JDR, the latest version is

1.6, with full instructions on running the program and installation. It is available from <http://members.home.net/hteller/digipan/>. Another piece of software that I like is WinPSK, written by Moe Wheatley, AE4JY this works well and may provide the features that you require. Try <http://www.winpsk.com>. You could also try 'Stream', <http://www.qsl.net/z11bpu>, which is also good but in my humble opinion not as good as the other two. Try each of these, they are free and then decide which one suits you best.

I have tried Winwarbler, which has lots of facilities. Like most software it is a matter of taste. Check out at [www.qsl.net/winwarbler](http://www.qsl.net/winwarbler). I also had a long look at Zakanaka and Logger. These seem popular but I couldn't get into them. I may need more time with these programs, as they seem to have so many facilities. Well worth a look at [www.qsl.net/kc4elo](http://www.qsl.net/kc4elo).

There are a few other pieces of software available that may be specially designed for other modes but have PSK as an 'add-on'. One of these is TrueTTY, <http://www.dxsoft.com/mitrtty.htm>, which is written for the RTTY enthusiast.

Another good source of information to be found on the net is <http://members.home.net/va3sf/amateurdigital.htm>

Several programs provide you with a 'waterfall' effect. This is where you can see the twin lines of a QSO in being 'falling' down the screen. With Stream the movement is a sideways effect with the onscreen display moving each time you select a different tone. Each program has lots of facilities for call sign, name and report capture and much, much more. Each is a comprehensive and well-written piece of software.

## Frequency

1838.150  
3580.150  
7035.150 for region 1 and region 3, and  
7080.15 for region 2 \*  
7.037.150 is also used in EU  
10142.150  
14070.150  
18100.150  
21080.150 (although most activity can be found 10 kHz lower)  
24920.150  
28120.150

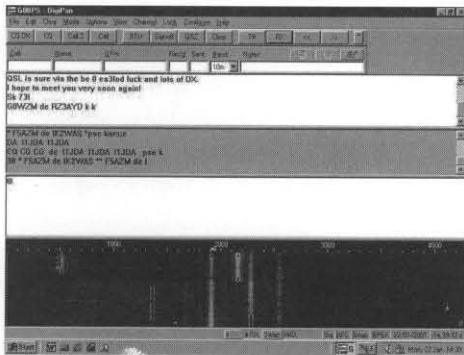

Fig. 1—Example of DigiPan screen.

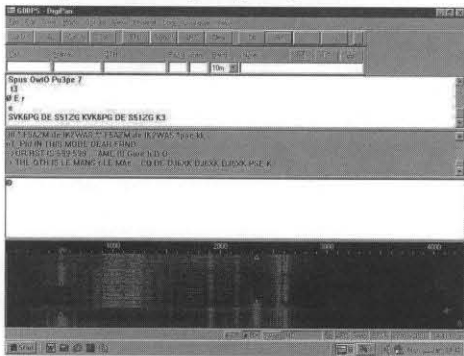

Fig. 2—A typical wide band digital signal next to 5 PSK signals.

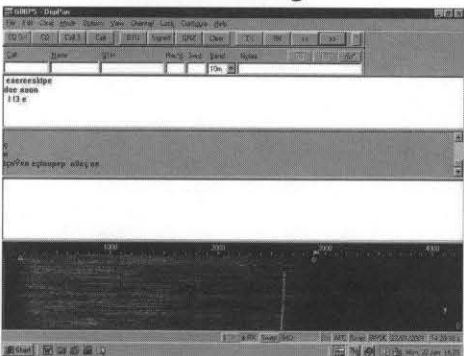

Fig. 3—An SSB voice signal with a CW carrier on the right.

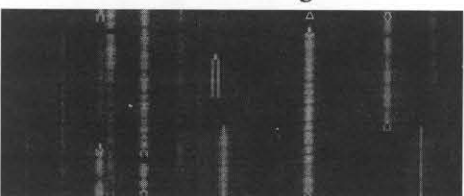

Fig. 4—A typical busy frequency. There are 12 signals.

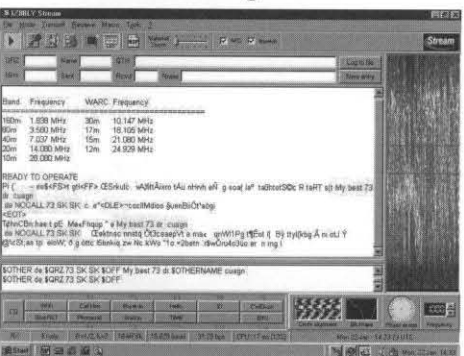

Fig. 5—STREAM program with the 'waterfall' on the right.

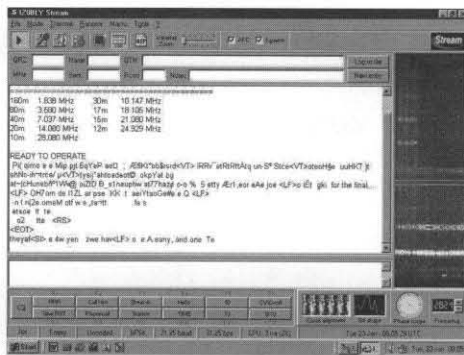

Fig. 6—another one of STREAM showing clear PSK signals.

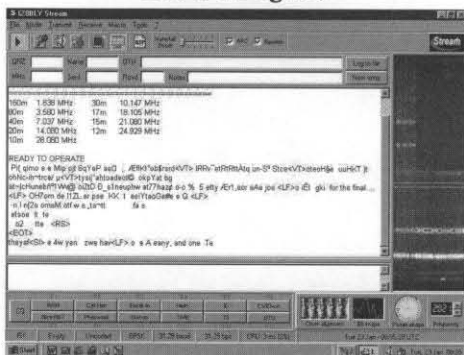

Fig. 7—WinPSKse in waterfall mode.

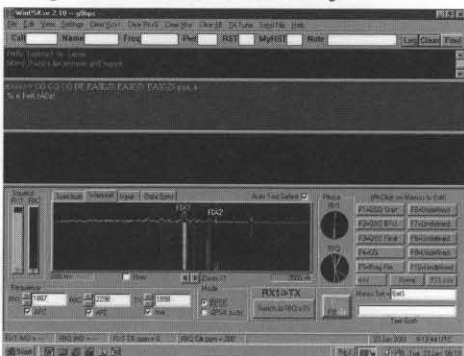

Fig. 8—Shows WinPSKse in Spectrum mode.



Fig. 9—Zak shows Zakanaka in operation

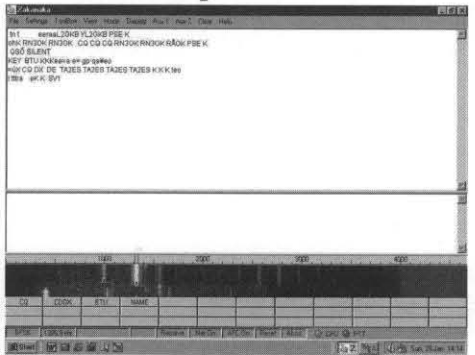

Fig. 10—WARB shows Winwarbler

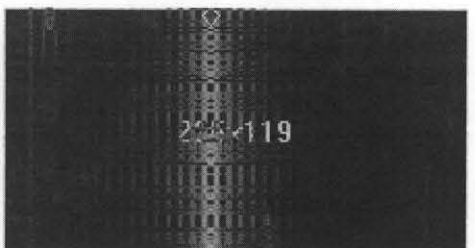

Fig. 11—A station with an IMD of  $-8\text{dB}$  > Nasty!!

The pictures say most of it. Each shows a screen capture of my own computer at various times of the day. In operation, once you have tuned to the correct frequency, if the band is open, then PSK signals will be seen tumbling down the screen. (See Figure-1). In most programs, you just use the mouse to 'click' onto one signal and if it is strong enough the text will appear in the appropriate window.

In each case, the transmit window is linked to one of the receive windows, so the user should make sure that you are actually replying to the correct received signal. I have answered a CQ to the wrong stream before now and I am sure that many others have done the same.

We also share some common problems with our American cousins. For instance, there is the ever-present problem of ground loops in the interface between computer and trans-

ceiver. Overdriving the transceiver is especially bad here in Europe, due to the interference it creates in an already crowded environment. This can be very unfriendly to other stations. In most programs you are able to check the IMD of the other station. The acceptable level is  $-25\text{dB}$  to  $-20\text{dB}$ . Under that you will be causing problems. I have seen signals at  $-5\text{dB}$ , very wide and taking up the same room on the screen as ten other clean PSK signals. Some of the signals shown are much lower than this level and the 'spread spectrum' of their signals can be seen on the screen. You cannot escape by transmitting a broad signal in PSK as everyone can see and measure it."

QSO's follow the same format as a CW contact, except you will get details of the other stations computer system as well. Often called the 'Brag File' with ops trying to outdo the other station as to the size of their hard drive. (Now where have I heard that before?).

One thing I do have trouble agreeing with is the 'final' where a station sends greetings to all family members, maiden aunts,

son's daughters and the unborn infants to come. Why not 'keep it simple stupid'. By all means send your regards to the transmitting station, even to any listeners. But to their family, friends, neighbours and local townsfolk? Really!

### Some things are a bit different here in Europe

We do have some differences.

The power level for true QRP operation on PSK has been the source of some discussion, but within the G-QRP Club it has been accepted as an output power from the transmitter of no more than 5 watts. It has been argued that, since PSK31 uses SSB to generate the signal, ten watts might be more appropriate. However, it is our opinion that the extra power relates to the high peak levels associated with a voice signal, and that a 5 watt limit is more appropriate to a data signal which does not have those peaks.

We also have our own contests, one of which I was privileged to enter. The annual G-QRP club's 'Winter Sports' takes place between Boxing Day and New Years Day each year. It is more like an opportunity to get on the air and rag chew than a contest.

Now I am sure that many operators will have made a lot of QSO's. Some of you may have even worked a few rare countries, but I have to admit that those I collected in the few days after Christmas amazed me. For example, when was the last time you were able to work a Kuwait station (9K2/KM5FY) and have a chinwag. None of the rubber stamp "599 73 QRZ" here, each time a long chat about what he was doing there. The station in Bosnia (T94DO) also stopped for a chat, The Gambia (C56RF) again for a chat. St Helena (ZD7JC) chat, Bonaire & Curacao (PJ2MI) chat, Cuba (CO8LY) chat... I have even worked W1AW (op Joe) in PSK. Very rarely will you find the standard CW or SSB report and QRZ... And remember—I am operating from the UK. (Yes I have worked all these in PSK).

During the week of the winter sports I managed over 100 QSO's and collected over 50 countries, worked all continents and I was running just 5 watts to a dipole. No beam antennas here (yet).

It will change, I am sure. As the mode gets more popular and more get on, the rare stations will revert to their normal QSO types. The same day I wrote, "I have yet to see any station working 'split frequency' but technically it is possible and I think will happen" I answered a CQ call from ZZ5PAV/

PU5OPR. As I waited for a reply I saw a similar signal appear as I went to receive. I used the second receiver to check what it was and found him answering my call. Each time I tried to net his frequency he replied a little higher. OK I thought, forget the simplex and work this one split frequency. And it worked. I can only assume his RIT was in. Oh yes, the ZZ5 is the Brazilian class 'D' licence.

### Come join the fun!

One of the best things about this lovely mode is the low cost of entry. All you need is a fairly simple HF rig and a modest computer. State of the art equipment is not really necessary. Because PSK31 is a very narrow bandwidth mode, reasonable stability is important. But most rigs are up to the task. In my case, I use an ancient Kenwood TS520 with a 2.8 kHz SSB filter. So on my screen, I can see a 2.8 kHz wide section of noise. In this section, I have seen over twenty QSO's taking place at one time.

You may want to listen first, to get the hang of it all. Start by downloading some of the free software we mentioned earlier. Feed the audio from your rig into the 'line in' port on your sound card in the computer. A good quality shielded cable should be used to stop any RF feedback when you eventually transmit. The audio may be taken from the external speaker output or the earphone output. Some rigs have all the facilities required on the rear panel Auxiliary connection.

The audio level control used is both that on the rig and also the sound card controls within the computer. On transmit the audio

#### COM port connections

Signal	DB9 Con.	DB25 Con.
RTS	Pin-7	Pin-4
DTR	Pin-4	Pin-20

is this time taken from the output of the soundcard, attenuated and fed to either the 'Mic in' or the auxiliary socket on the rig.

#### —On the Front Cover—

Richard G3UGF, and James 2EIJB at Rishworth School Radio Club, Nr Halifax West Yorkshire. Operate QRP PSK with an SGC2020 into a Cushcraft R3 vertical on the back of the Science Lab on Saturday mornings.

The aim of the experiment was to see what they could work with 5 watts PSK and 5 watts CW. The experiment was to compare three things. Conditions, Accuracy and Signal to Noise Capability comes out very good!

PTT control can be manual or controlled by the computer.

Connecting the computer to the rig is quite easy and only a handful of components are needed. As mentioned the drive from the computer to the rig must be reduced and a simple attenuator as in **Figure-1** can be used.

Whilst it is easy to lean over and switch the rig to transmit by hand, it is much easier

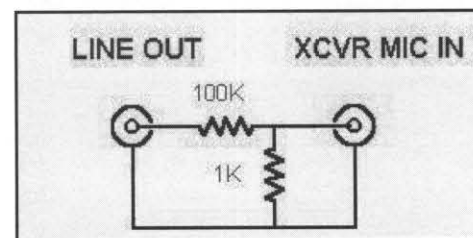

Audio line from the computer to rig

to let the computer do it via a COM port. A simple transistor switch as shown in **Figure-2** will do the job. The 'Ever so umble' 2N2222 will do the job fine.

### So there we have it!

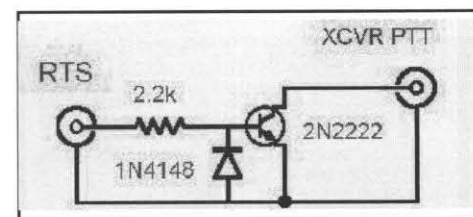

How to connect your PTT to a COM port

Check out the frequencies we have given you, get the computer switched on, and the rig fired up (to five watts of course).

What can be achieved by this mode that CW cannot? The answer is probably very little. Remember the oft-quoted statement "CW will still get through where all others fail." **PSK will get through as well as CW in my opinion.** I have worked stations and seen a faint line on my screen when I couldn't actually hear any signal. OK as my wife tells me I am going deaf, as I get older.

Have we convinced you to give it a try? Join me (and many others) in the wonderful world of low power data transmissions. ●●



# A Switchbox for Soundcard Digital Modes

Don Wilhelm—W3FPR

w3fpr@arll.net

*If you are not familiar with the use of computer sound cards and associated software for digital modes such as PSK31, there are two good background articles by Steve Ford, WB8IMY, in the May 1999 and January 2001 issues of QST. —W1HUE*

I have spent a short time on PSK31. At first, I just connected a cable (with 1/8-inch plugs on both ends that I obtained from Radio Shack) from my K2 Transceiver to my computer soundcard line-in jack. This and the DigiPan and WinPSK programs enabled me to copy PSK31 signals – I adjusted my sound card input volume controls and the audio gain on my K2 so that I had a nice speckled blue background in the waterfall display, and I was seeing FB print on my computer screen.

It was not very long afterward that I wanted to transmit this PSK31 stuff too. Things got a bit more complex at that point. I had to put an attenuator in the cable from the sound card output line to my microphone. After some experimentation with values I got a respectable signal into my K2 and I could transmit this digital stuff too, but I was using manual PTT, which made things a bit cumbersome going from receive to transmit.

The next step was to automate the PTT as well. The instructions in DigiPan and WinPSK showed a simple circuit – just a resistor, a diode and a transistor. I hooked it up and hid all the parts in the shell of my serial port connector with just one shielded wire going to my K2. All I had to do is tell the PSK31 program to transmit and it all happened!

It was not long after all that excitement that I wanted to use normal SSB, and here I had all these plugs in my K2 going to my computer that needed to be unplugged. Then and there, I decided that there should be an easier way; I needed a simple switch to change from one mode to another to keep my frustration level on an even keel.

I had a switch box on hand that was designed to switch serial port lines from a computer to two devices (or the other way around). This switch had a nice size box, a built in 9-pole 2-position switch and connectors on the back. The inside had plenty of room for me to mount everything including the microphone preamplifier.

My Grand Plan and Mods to the K2

[www.qrparci.org/](http://www.qrparci.org/)

In addition to putting all the switching into one box, I wanted to end up with only one cable connection with my K2, and also to be able to disable the speech compression of the K2 when I switched to PSK31 without thinking about changing it through the K2's menu.

To accomplish all that, I had to modify the K2 to add the headphone audio through the microphone jack and I needed yet another signal through the microphone connector to disable the speech compression. Adding the headphone audio was easy – that is mainly wires – but disabling the speech compression was more challenging.

Examination of the SSB schematic revealed that the COMP0 signal was active low, which made it easy in principal – just short it to ground to disable the compression. In practice things are not that easy – I would be adding relatively long wires to ground it in my switch box, and that would likely couple noise into this line at times other than when it is grounded; some isolation was required.

I ended up with a simple circuit of two resistors and two transistors configured as a non-inverting open collector switch that I could mount on the SSB board (see Fig. 1 on next page). I was able to package them so they mounted right on top of U3 with the tops of the transistors not much higher than the adjacent electrolytic capacitors. This circuit was built with “flying leads” construction to minimize the package size. All the components self-support nicely and the lead lengths are very short. The result is effective control of an analog signal line at the output and a digital signal input that should have good noise immunity. If you have worked with RTL digital components, you will likely recognize the circuit.

For my new audio output, I used an 82-ohm resistor and 2.2  $\mu$ f capacitor from the junction point of R35 and R36, duplicating half of the components that normally go to the stereo headphone jack. I did not want a fault in the external box to disable the normal K2 audio output. These components were added below the RF board quite near the

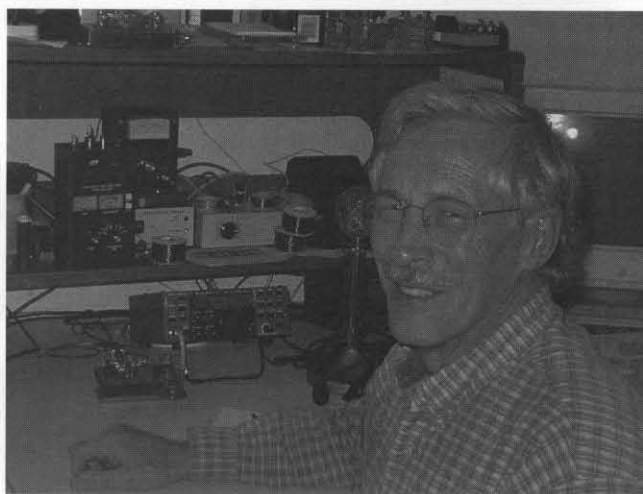

headphone jack.

## Microphone Header Configuration

My microphone header does not have any wires on it. I originally connected everything straight across using jumpers normally used in computers. To add the signals for headphone audio and compression disable to my mic connector, I chose pins 4 and 5. Pin 5 was already unused, and I felt I could sacrifice both the UP and DOWN button functions since my microphones didn't use these anyway. That left me with pin 3 reserved for any future needs. Your pin configuration may be different if you are using another type microphone and don't want to alter your mic's plug wiring.

To connect my new wires to the microphone header, I used more of the computer jumpers. Some of the jumper types have an exposed part of the metal connecting bar at the top with a small opening below that. I soldered wire to the top and plugged it onto the header using only one side. These connecting jumpers must only connect to the numbered side of the header, which then connect to the mic jack. The side of the header with the signal names connects to circuits inside the K2 and should be left open for these added circuits. The jumper configuration is shown in the photo of Fig. 2.

## The Switchbox

My switch box is shown in Fig. 3. This switchbox uses the components from a computer COM port switch. Only two of the original connectors are used and only four of the 9-poles of the switch. I mounted my microphone preamplifier inside the box. I also

# Add Compression Disable Circuit

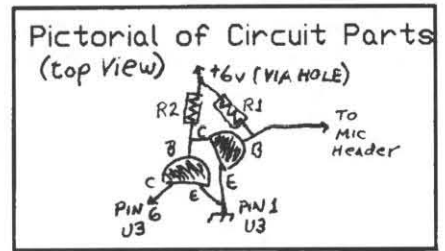
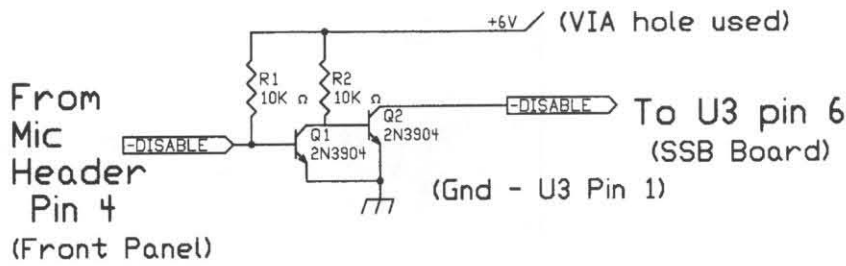

# Add Headphone Audio to Mic Jack

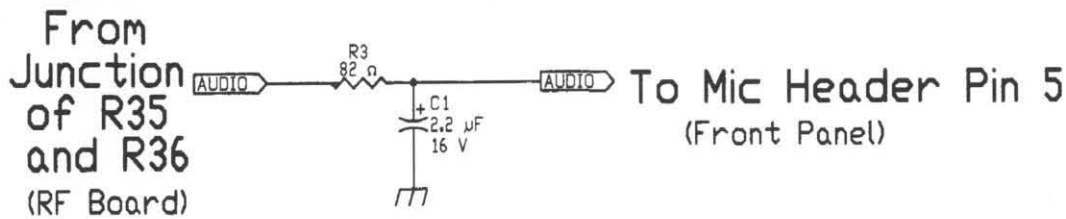

Fig. 1—Modifications to K2 to disable speech compressor and add audio output to the microphone connector.

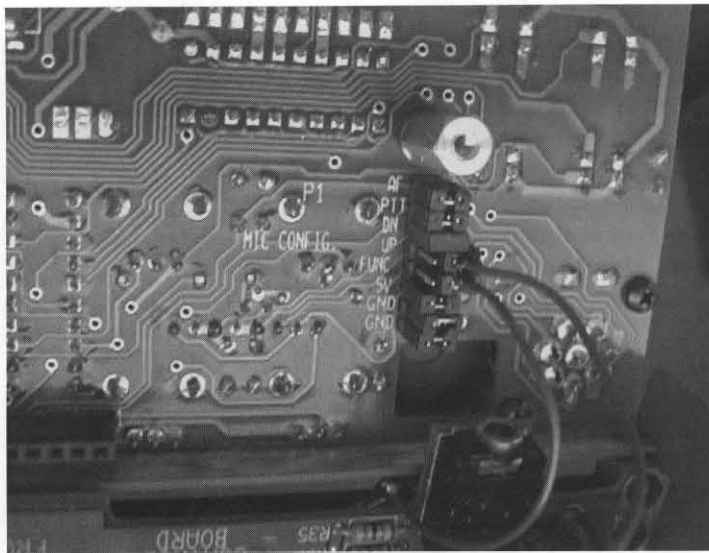

Fig. 2—Wiring added to mic configuration header.

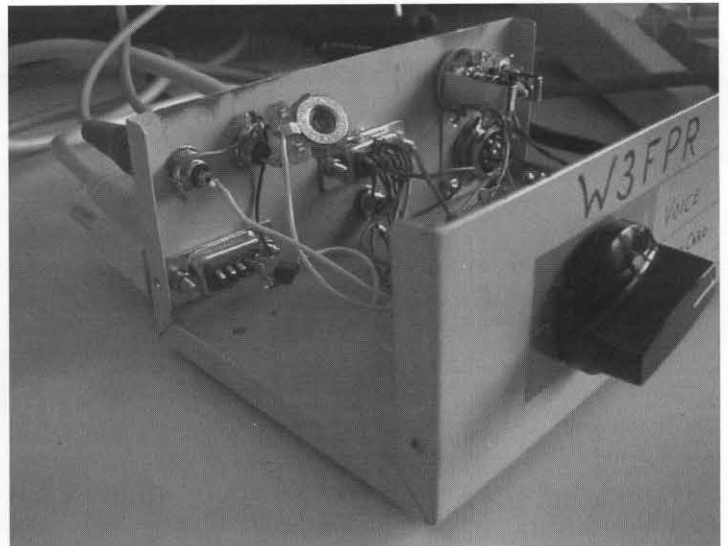

Fig. 3—View of modified switch box.

added a jack for using an external footswitch for PTT (bonus – I can now go QLF on CW).

The headphone jack is shown in the schematic (Fig. 4) as monaural, but should actually be a stereo type with both the tip and ring wired in parallel.

The internal wiring can be seen below in Fig. 3. The DB9 connector in the lower left goes to the COM port and the PTT circuit is built using “flying leads” construction. The RCA jacks above it are for the soundcard

connections. The one with the trimpot attached is for the line out/K2 mic in signal. Adjust the trimpot for the correct audio drive to the K2 with the computer’s volume control set to midpoint or below.

The center DB9 connector is used for the cable to the K2 mic connector. I used a shielded RS232 serial cable for that task. The shield is grounded to the DB9 shell at the switchbox end and connected to my pin 8 at the K2 end. Wire this connector to corre-

spond to your normal microphone wiring so that you can use your microphone with either the switchbox or directly on your K2.

*Note:* I have since added a small 1:1 audio transformer between the 100K trimpot and the switch contact to eliminate noise induced by a ground-loop. ●●

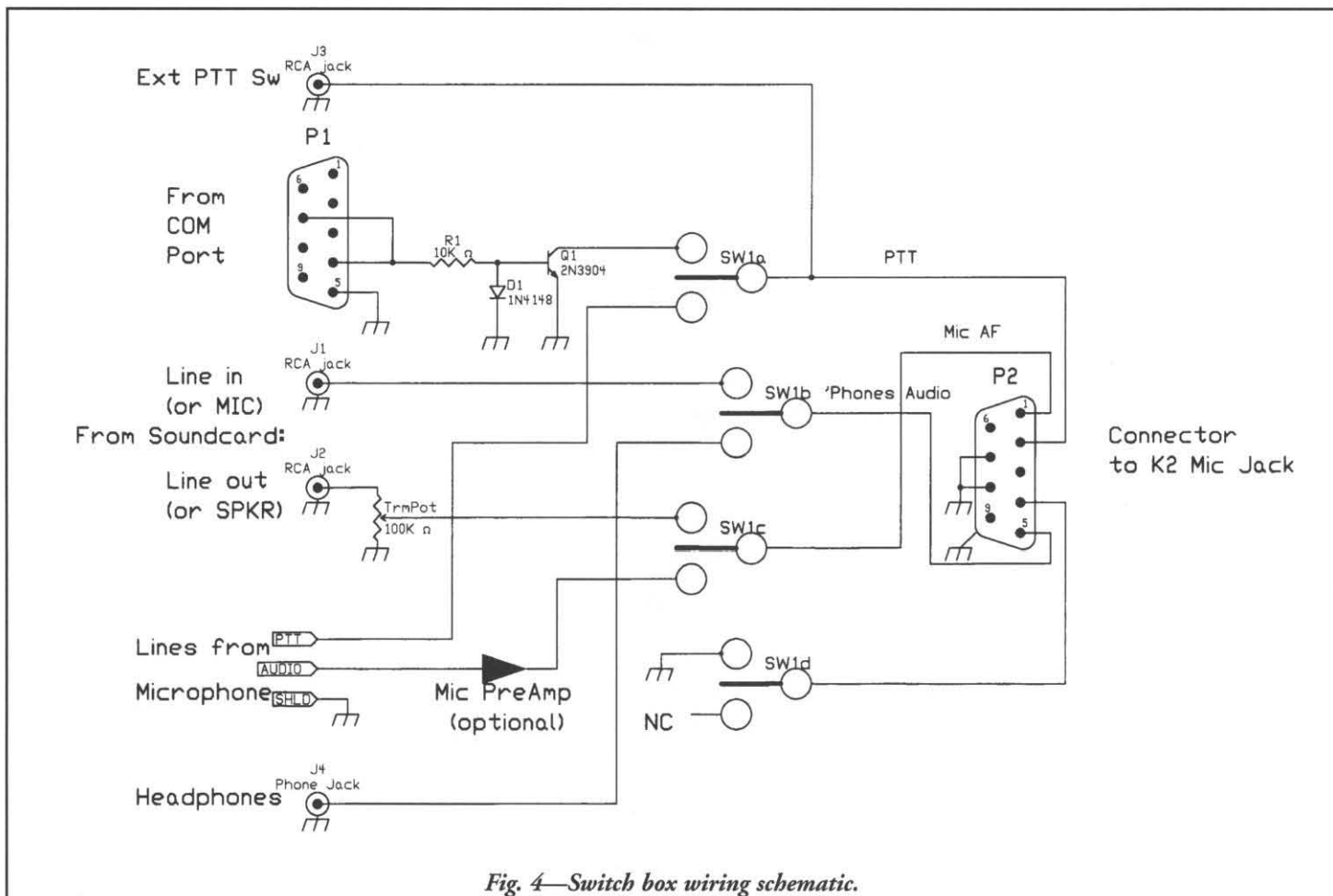

Fig. 4—Switch box wiring schematic.

## FDIM OR BUST!

### 2001 QRP BIKE TRIP TO DAYTON

“Four Days in May” is an annual gathering of QRP Operators held in conjunction with the Dayton Hamvention each May. In May 2001, a small group of QRP Bicycle Mobile Hams will be cycling from Ontario to Dayton, to participate in the activities and to have a great deal of fun just getting there!

#### THE RIDERS

**Ken LaRose VE3ELA** will be riding a Raleigh Avalanche Mountain bike equipped with an HW-9 and hustler whips

**Russ Dwarshuis KB8U** will be riding a recumbent bicycle (either a Tour Easy or a Rans) equipped with Tokyo Hy-Power HT-750, trying for some QRP 6m contacts, if the sporadic Es will cooperate! whips

**John Cumming VE3JC** will be riding a Gary Fisher Big Sur equipped with an Elecraft K2, DSW-40, and Outbacker Perth Antenna

#### THE ROUTE

The trip will begin in Delaware, Ontario. We will cycle to Leamington in time to catch the Sunday afternoon ferry to Pelee Island and then to Sandusky, Oh.

#### QSLs

QRP ARCI will provide commemorative QSLs for this occasion. Send your QSL and an SASE to:

QRP ARCI - Bicycling to FDIM  
848 Valbrook Court  
Lilburn, GA 30047

Follow QRP-f, QRP-l and <http://www.geocities.com/ve3jc/fdimor.htm> for details.

# Using the FT-817 in the PSK31 Mode

Barry Johnson—W4WB

w4wb@oetc.com

The new Yaesu FT-817 HF/VHF/UHF all-mode transceiver has been a welcome addition to my shack and a fine travelling companion since last Thanksgiving. Among its many capabilities is the inclusion of two dedicated modes for PSK31 operation, viz., one each for USB and LSB injection. The basic setup is rather easy by using the DATA port located on the rear panel of the FT-817. This connector is compatible with the Yaesu CT-39A packet cable or you can make your own using the standard male six-pin mini-DIN connector (the same one used for a PS/2 keyboard or mouse). Since the small size of the mini-DIN connector makes it difficult for some to attach wires (particularly those having simply straight pins), an alternative is to install a male 5-pin DIN connector onto the cable and then use a PC/AT keyboard adapter (5-pin DIN female to 6-pin mini-DIN male such as Radio Shack part 950-0273). The FT-817 DATA port provides DATA OUT, DATA IN, PTT, and ground.

I have experimented with two approaches to connect the FT-817 to the sound card in the computer. The first approach was to connect the FT-817 and the sound card directly. The DATA IN provides a maximum input capability of 1.0 V pp with impedance of 10 KW. The DATA OUT can produce a maximum output level of 300 mV pp with impedance of 10 KW. This audio output is independent of the setting of the FT-817's volume control. The FT-817 will transmit when the push-to-talk (PTT) line is grounded. In this minimalist direct-connection approach, the transmit-function is accomplished manually. A suitable switch is used to control the PTT line. The LINE OUT and MIC INPUT from the sound card are connected to the DATA IN and DATA OUT, respectively.

The next step is to set the FT-817 to the DIG (digital) mode using the selector buttons on the top of the unit. Now select Menu #25 (DIG MIC) and set it to about 20. Select the ALC metering from Operating Function Row 9. While transmitting, adjust the volume and/or Wave slider controls on the computer to achieve a few bars of indicated ALC. You may have to fiddle with the setting of the DIG MIC and the computer's volume controls to achieve the proper level of ALC. On my unit I have found four bars to be the optimum setting. To achieve the

proper audio input level for the PSK31 program, use the MICROPHONE level control in the computer.

A concern of using direct connection between the computer and the FT-817 is the possibility of EMI and other noise forms. During actual operation in this configuration, no anomalous behavior was observed.

The second approach was to build an interface that electrically isolates the audio signals flowing between the radio and the computer. One can build their own or buy a suitable interface from various vendors. In my case, I purchased a kit (Model FTMDIN) from BUX CommCo ([www.packetradio.com/PSK.htm](http://www.packetradio.com/PSK.htm)) to construct for the interface. The construction is straightforward; however, since the audio input to the FT-817 is high level, the series resistor in audio input of the FTMDIN was changed from 10 KW to 1 KW to reduce the attenuation of the signal from the sound card to provide a maximum signal to the DATA IN line of about 0.7 V pp. The FTMDIN has dimensions of 6 x 6 x 2.5 mm and does not require an additional power source. Another important feature of the interface is that the transmit-function is under control of the software via a serial port on the computer.

The FT-817 settings in this case are essentially the same as in the former approach except that the DIG MIC is set to about 50. The transmit setup is similar to the direct-connection approach except that you should adjust the potentiometer on the FTMDIN circuit board to indicate 4 bars on the ALC meter while transmitting. Additional fine tuning to the audio levels may be accomplished

by using sound cards level controls.

In actual on-the-air tests, both approaches produced acceptable signals. The IMD using the direct connection was about -20 to -22 dB and decreased to -30 dB when the FTMDIN interface was used. Comments were received stating that the signals using the FT-817 with the FTMDIN interface were very, very clean. Once the PSK31 setting have been determined, operating using the PSK31 mode is most enjoyable. If you have the optional CW filter, it may also be used for PSK31 operation. This filter has a bandwidth of 500 Hz (-6 dB) with a shape factor of four. Generally you will want to use the wider bandwidth to have a "panoramic view" of the activity in the PSK31 "band." When a very strong station appears, it frequently becomes difficult to maintain a QSO due to the shift in AGC. If you can use your CW filter to isolate your desired signal, the affect upon reducing the interference by the offending station can be dramatic. To move the filter about within the current spectral window, use the IF shift control. You can see where the filter is placed in the spectrum by viewing the waterfall display.

Using the FT-817 for PSK31 operation is simple and works well at the full 5 W output level. If you haven't tried PSK31, then give it a try using any of several freeware software programs. Many people call it the "magic mode" because it works so well for low-power stations communicating worldwide. Well, there is nothing magical about it; it's just a very clever and efficient modality for communications that is rapidly growing in popularity! ●●



*Craig—AAØZZ and Pat—KØPC, 2 of the Minnesota QRP Society WQORP team members who helped achieve a whopping 470,592 score! Location is Minnetonka Community Center. 12° F temp. gives a killer multiplier.*

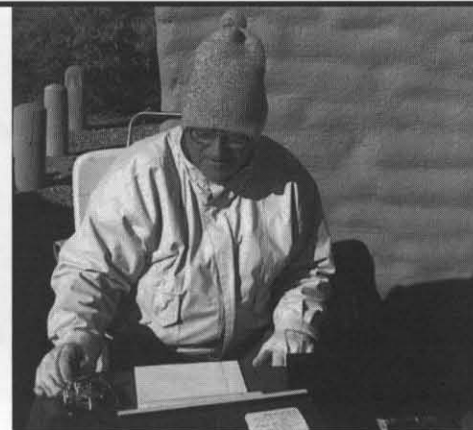

*1st Q was at 19 degrees F when Karl F. Larsen—K5DI did FYBO at Leesburg Dam State Park, NM, for 4 hours.*



# How To Build "Kwikits"

Denny Baker—W9OCP

dlbaker@presenter.com

A "Kwikit" (quick-circuit) is a way to quickly build an electronic circuit and has nothing to do with Elmer Fudd! The idea occurred to me four or five years ago but didn't really come together until just recently. I have always been a very active builder and have usually used purchased circuit boards or, for over 20 years, the little double circuit boards from Radio Shack. The electronics magazines and QRP journals contain a lot of very useful circuits but circuit boards are not always available and besides, we hams like to personalize our projects by modifying them to be exactly what we want. The "Manhattan" building technique has become popular to provide ease of building and change but I like my little circuit boards to look neat, be small and work well. I'm also frugal, to say the least. Kwikits satisfy a lot of my building needs by being very easy to build, low cost, made of available materials and look great. Sound interesting? Read on!

The Kwikit is a circuit board system that uses either bare, pre-perforated boards or a board material that has been drilled where components will be attached. Small diameter copper wire is used for the traces and small circular loops are created on the opposite side of the board for component mounting. Component density can be almost the same as the standard printed circuit board and even more dense if more than one component is attached to the same loop. The wire is passed up through the desired hole and back down through the same hole. The loop is created when a mandrel is placed through the loop before it is pulled down tight against the

board. The circuit is made by either duplicating a circuit board layout or a drawing made to match the schematic diagram; the wires and loops create the electrical circuit. The result is a flat board, populated with small loops, where components are to be attached. In a recent exercise for this project, a Tuna Tin Transmitter Kwikit was made using a 1 3/4-in. x 2 7/8-in. board.

All materials for the Kwikits can be obtained locally at Radio Shack or Home Depot. Radio Shack sells a 6-in. x 8-in. perforated phenolic breadboard for \$3.49 (RS 276-1396) or a 4-in. x 10-in. higher quality, perforated board for \$9.00 (RS 910-1874). The circuit board for the Tuna Tin, mentioned earlier, was made of a Formica counter top material, sample chip, obtained at Home Depot. For larger or more Kwikits, a 24-in. x 30-in. piece of Formica was priced at less than \$12 and scrap pieces may be available from some cabinet shops. The wire is four conductor telephone wire also available at Home Depot for cents cents a foot. For \$2.00, you get 160 feet of circuitry! Be sure to get the cheapest wire because it's usually #24 or #26 wire and is easy to create the little component mounting loops. Some places sell #22 wire but it's harder to work with. So, my Tuna Tin Kwikit cost me less than five cents. I told you I was frugal! This doesn't mean that you should clean off the sample display board at your local building supply center to build a whole new station!

A word about the Formica, actually Pionite, chip (raspberry color). If you do the usual test of putting it into the microwave oven for 30 seconds, it gets hot and a piece of G-10 perforated board gets warm, so it isn't a perfect insulator. Most of the little circuits appearing in magazines don't run at 2.5 GHz so it should not be a problem. As a practical test, I built a little 130 MHz aircraft band super regenerative receiver and it works fine. Holding a second chip against the frequency coil also had about the same effect as a piece of G-10 perforated board. Purists may be troubled by a less than perfect insulator but purists can also drive a sane person over the edge. Just be aware that a problem could arise at very high frequencies, voltages, or power; common sense should prevail. If you're not a purist, just think of all of the neat little colored circuits you can build! You can even color code the Kwikits by function.

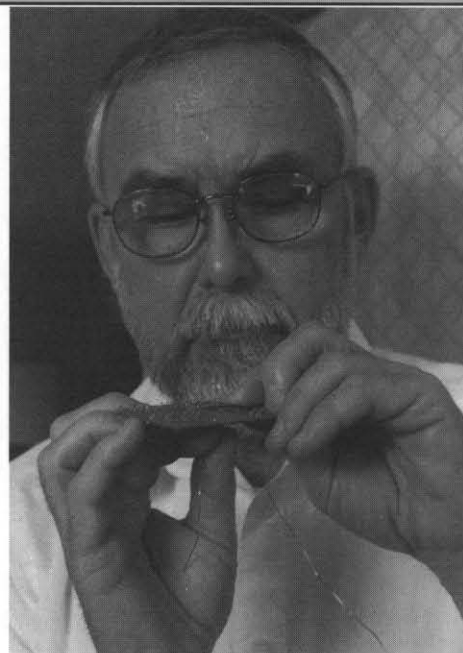

Before beginning building a Kwikit, think about the advantages of this type of building. Adding, subtracting or changing a circuit trace or component mounting point simply involves pulling the loop back through the hole or clipping it above the board and pulling it back through the hole. Adding a trace is accomplished by simply twisting to an existing trace and soldering it. Because the trace and mount loop is copper wire, you cannot make the trace lift by excess or repeated heating. Changing components or probing is easy because all connections are made on the top of the board. The Kwikit can be made directly from a printed circuit template because the loops are small and take little space. The resistors can be mounted flat or vertical to save space. The Kwikit can use re-cycled parts because only very short leads are needed. Parts salvaged from old TV circuit boards are perfect. Using this method of creating circuits results in a very neat looking board, contrary to the Manhattan style. No glue, adhesive, resist, etchant, or copper laminate is needed either. Because creating the circuitry simply involves threading copper wire through pre-drilled or punched holes, almost no skill is needed. If you have a closet needlepoint fetish, it will pay off here. Using the proper board material and larger wire, even high current or high voltage circuitry can be built. Again, best of all, the materials are very available and low cost.

While very little skill is required to build a Kwikit, but it helps to try a few traces and



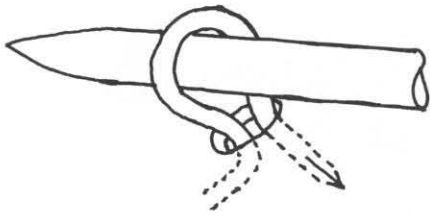

loops to see how they are made before beginning a circuit. I use a 0.048-in. diameter dissecting needle as a mandrel, because it was available, but recently bought Dritz "Yarn Darners" needles in a fabric store for \$1.25 for a package of seven needles. They are different sizes and work fine. Different size loops can be made with the various size needles and the needle taper is an advantage when removing it from a formed loop. Even though the wire is #24, the finished loop, about 0.050-in. inner diameter and about 0.090-in. outside diameter, is quite strong and rigid. For the Tuna Tin transmitter, I used a 0.043-in. (0.15 mm) surplus circuit board drill obtained at a hamfest for 50 cents, and the wire was easily pulled through the holes resulting in very neat loop connections. The hole size doesn't seem to be critical but if they are too small, it is difficult to pass the wire through the hole for the second time when completing the loop. The 0.043-in. hole size seems a little too large because the loops rotated when routing the trace wire to the next loop hole.

If you are not going to duplicate a printed circuit or work from the foil pattern, a drawing of where to run the wire and make the loops will be necessary. I lay out the circuit and try to scale it according to relative size of the parts. Using the perforated board material with the holes on a 0.10-in. x 0.10-in. grid, a resistor has three open holes between the loops and a capacitor has one hole between the loops. This takes 0.40-in for a resistor and 0.200-in for the capacitor. For a vertically mounted resistor, the loops can be made at the 0.10-in spacing if care is taken to be sure the loops do not touch. Size your circuitry according to the parts you have on hand but the above "rule of thumb" seems to work well. If you lay out the Kwikit carefully, you should be able to avoid jumpers by crossing under resistors or other circuit components. One real advantage of laying out the circuit on paper before actually starting is to space the loops knowing that a "cross-under" is needed. For example, if a "cross-under" is needed by a transistor, the E-B-C loops can be spaced to allow the wire to pass without touching any other traces. Of course, an actual cross-over of the circuitry can easily be made by simply slipping a piece of insulation over one of the cross-

ing wires. Once laid out on paper, write in the values of the components to minimize the chance of missing one and, later, ease attaching the proper component in the right loop. Alternately, the part identification can be written right on the Kwikit board, between or alongside of the loops.

Once you are satisfied that the layout is correct and has any modifications that are desired, it's time to start building. If you are not using the perforated board, transferring the pattern and drilling will be next. Cover the plain board with masking tape and mark where the holes are to be drilled either by punching through the PC layout pattern or from your Kwikit drawing. I like to use a small drill bit in a pin vise to actually start the hole but very close positioning is not usually necessary so a pencil mark on the tape is adequate. Avoid center punching the Formica type material because it may crack; just make a mark where the drilling is to take place. Finish drilling the holes and remove the tape. What you should have is a board with holes where the loops will be positioned and it can be checked against the PC layout pattern or your drawing. Carefully remove the tape from the drilled board and stick it down on the paper next to the drawing; it will simplify building the final circuit because it is the actual board positions of the parts noted when you penciled in the values.

I normally begin at the input end of the circuit, like at the crystal and oscillator of the Tuna Tin, and do not pre-cut the board. This will allow adjusting the size up or down as the Kwikit is being built and once completed, it's easy to cut it down to size but somewhat difficult to "cut it larger". Take my word for it. The Tuna Tin on the sample chip required careful building. It really doesn't matter where you start but most schematics are drawn from left to right. An existing printed circuit is easier because the layout is already done and all you have to do is "trace and loop". You will quickly learn a technique for building the circuits but a few tips are helpful.

When beginning the first loop, leave about 1/2-in. of wire so you can hold it in place while pulling the first loop tight. You can position it where you want and clip it to length later. When going to the second or subsequent loop positions, it is helpful to leave the mandrel in the previous loop as you go up through the hole and pull the wire tight against the board. This way, you won't distort the previous loop and they will nearly all be the same size. When passing the wire back through the hole, to make the loop, hold the

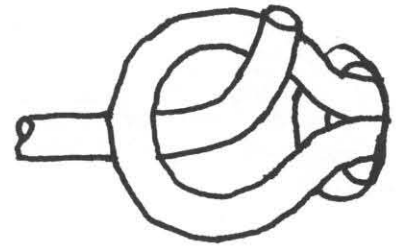

wire leading up to the hole or it may lift as the loop is closed. When pulling the wire back down with the mandrel in place, have the mandrel slightly lifted so the wire isn't pinched. If pinched, it may cause the wire to break when pulled and you will have to remake the loop and splice the wire. If you break the wire, simply make hooks of the existing wire and the added wire ends, hook them together, pinch them with your long nose pliers, and solder them later. I may also solder the beginning pigtail of the first loop to the trace just to "tidy up" the wire side of the Kwikit. When creating a "cross-under" in a narrow space, sometimes I slide a little piece of the original insulation over the wire for protection. When the Kwikit is completed, you will have a board with uniform sized small loops where the components are to be mounted. It makes a very neat looking circuit board. The board can now be cut to size but be sure to leave room for mounting holes or whatever you will use to mount the completed circuit in your project box or on a breadboard.

Components, like IC's, need special treatment, in both layout and mounting and here is how to do it. There are several ways to create the IC mounting site. In any case, you need to drill the holes for the IC pins or socket pins. One way is to make two holes for each pin hole, away from the IC site. Make a loop in the hole farthest from the IC pin hole, and bring the connecting wire up through the hole between the loop and pin hole. Pass the wire across the board and down through the IC pin hole and clip it but leave about 1/16-in. tail to later solder to the IC or socket pin. You may want to drill the IC pin holes a little larger if you choose this method. Bending the pins over, against the board, will help hold the socket or IC in place. The second way to achieve the IC mount is to drill just the IC pin hole and the loop hole, next to the pin hole. Make the loop, as usual, and simply leave a small tail of wire to wrap around and solder to the IC or socket pin. Using the first method is like putting the IC or socket pins into a "built" socket. A third way

way of making an IC socket or IC mount is drill holes where pins will be positioned and make a loop at each pin site. When you are ready to mount the IC or socket, bend the loops slightly away from the center of the IC and insert the pins of either into the loops. It will take a little fitting of the pins or loops before soldering into place. Using this method requires extra care when inserting or pulling the IC from a socket so the pins are not collapsed or broken. Try to mount the IC's or sockets before other parts or soldering might be difficult. Again, all parts are mounted from the topside of the Kwikit so changing them or probing is very easy.

It's now time to mount the components on the Kwikit. Using the printed circuit layout or your drawing of the loops and penciled-in component values, start mounting the components. There are two ways to mount them but from the side seems to be the easiest. Bend the lead from the component down, as if you were going to put it into a circuit board, and make a second 90 degree bend bringing the lead away from the side of the component. If you are recycling parts removed from a circuit board, normally, the first bend is already made. Simply make the second bend perpendicular to the component. You now have the component with a little L at each end, and beneath it. At the mounting location, depending on the orientation of the mounting loops, you may have to rotate them 90 degrees to accept the end of the little "L". Simply grasp the loop with your long nose pliers, and rotate it or them 90 degrees. Now, insert the L's on the component into the loops and solder them into place. It takes a lot less

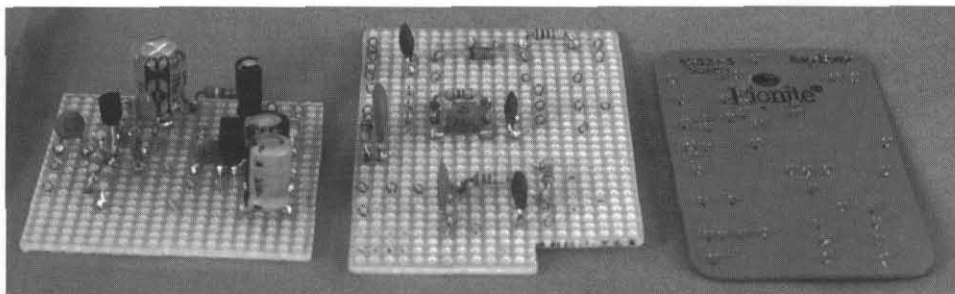

time to do this than it does to tell about it! The second way to mount them is to make the second bends along the axis of the component, in the same direction, and insert the leads into the loops, rotated perpendicular to the component axis. This does not seem to work or look better than inserting the lead into the side of the loop but provides another option to mounting the parts. Vertically mounted resistors will have "appropriate" bends to have the same small "L" to insert into the loop. Continue to mount parts and solder them into place until the board has all of the components mounted. If not done earlier, mount the IC's or sockets as described above and solder the wires to the pins. If you insert and later want to remove the IC, be sure you lift it by prying it from the socket or the wires may be over stressed. When you have 1/2 of them in place, hold it at arm's length and appreciate how nice this little circuit will look when finished! Power, audio, antenna, etc. lead wires are attached by simply inserting the wire into a loop and soldering it. The loops provide convenient, strong anchor points.

It occurred to me, while building a small circuit, that even surface mount components can be used with the Kwikit method of cir-

cuit building. Simply bend the loops to fit the SMD and solder it to the loops. The loop should have been rotated so the flat side of the loop is against the end of the SMD. You may have to plan ahead and lay out the loops to match the SMD because "rule of thumb" loops could be too far apart. Electrolytic capacitors seem really well suited to the Kwikit but with planning, most of the other components can be used, if not ridiculously small. But, then again, the Kwikit can't peel potatoes, either.

The Kwikit will, by no means, replace circuit boards. It was never meant to replace them and circuit suppliers need not fear this method of creating circuitry. This method of assembling a circuit provides the home builder with yet another way to build the circuits that is convenient, fast, easy to build, and look good. They take less room than Manhattan style circuits. Complex circuits can be built either on a larger board or on a number of small sub-assembly Kwikits. Now, building a circuit can be done easily because all necessary materials can be kept on hand for almost any project. It can go from an idea to a great looking, custom circuit, in a couple of hours and doesn't require a great deal of ambition! I really like that last part! ●●

## FYBO 2001 RESULTS—SINGLE OP CLASS

CALL	QSO'S	SCORE	CALL	QSO'S	SCORE	CALL	QSO'S	SCORE
W9XU	187	394944	K7BOD	39	9360	NK6A	34	1360
N9AW	153	330480	K2UD	19	9120	W9SUL	51	1224
N9NE	161	301392	W3CD	34	8704	K5DI	7	1008
NK9G	103	177984	K4FB	25	8400	AB8DF	27	972
W2AGN	53	59360	N3XRV	67	7772	NQ7X	46	966
K6XX	79	58776	W2RBA	12	6912	AB7OA	5	640
WD7Y	76	55936	KI0KY	13	4160	AL7FS	33	627
N0TU	46	44160	K0CO	26	3744	N4UY	27	459
K7TQ	41	26240	W1QHG	12	3456	W7/JR1NKN	5	400
WD3P	31	22320	W1PID	9	3240	KE6RS	10	360
AA0B	23	22080	KV2X	10	3200	WA5BDU	7	336
VE3ELA	23	18768	AB5XQ	14	2688	N4VBV	4	256
K9IUA	33	15840	K0CO	26	2028	W3DP	14	126
K7RE	45	13500	N7CEE	7	1568	N2CQ	6	36
K5OI	18	9504	N4FNG	58	1508			

Thanks to Bob, NK7M for compiling this list. ●●

# Contest Operator of the Quarter--NOUR

Randy Foltz—K7TQ

foltz@turbonet.com

This is the first version of the *Contest Operator of the Quarter*. In each issue I'll talk to an interesting QRP contest operator. One purpose is to make the person on the other end of the contest QSO a bit more personable. Another is to see if we can learn from the best.

The first contest operator of the quarter is NOUR, Jim Lageson. He lives in Brooklyn, Minnesota, which is near Minneapolis. Many of you have seen his call in contest results both in the QRP Quarterly and in QST. If you've participated in recent Fall or Spring QSO Parties you've probably worked Jim. His contesting resume is pretty impressive. He was 1<sup>st</sup> in the 2000 End of Summer PSK-31 Sprint, 2<sup>nd</sup> in the 2000 Spring QSO Party with over 1.2 million points, and was 3<sup>rd</sup> in the 1999 Fall QSO Party with over 2.2 million points. As a single operator, QRP he made 632 contacts in ARRL's Field Day, 2000. I'm not done yet. In non-QRP contests running QRP, NOUR had a good year in 1999 with a 5<sup>th</sup> in the CW portion of Sweepstakes, a 4<sup>th</sup> in the 10 m CW contest, and a 3<sup>rd</sup> in the ARRL DX CW contest. He continued those ways in 2000 with 5<sup>th</sup> place finish in the ARRL DX CW contest. When I asked him if he be the first contest operator of the quarter, his modest reply was that he was always a bridesmaid, never a bride.

**K7TQ:** Jim, why do you contest?

**NOUR:** I contest because I really enjoy it. Computer logging has made it much more enjoyable, most of the tedious jobs are gone, such as dupe checking and scoring. I am more competitive than I want to admit, so I do enjoy the thrill of the "race." As far as why QRP, field operations are much easier, no TVI/RFI problems, and most of all the great bunch of QRP op's I get to operate with and against. Also, the playing field seems pretty level, most of the stations are fairly equal.

**K7TQ:** With all those great accomplishments, you must have stacked beams on multiple towers in the middle of a 10 acre field.

**NOUR:** No, I live in the suburbs with a good size city lot, not enough tall trees yet, but friendly neighbors. My home station uses an FT-920 as the main radio and an IC-735 as a second radio. My antennas are an old 3-element tri-bander up 40 feet for 10, 15, and 20 m, a 40 meter dipole, and an inverted L on 80 and 160. When I am out in the field I



bring the trusty IC-735 (great radio) with a center-fed Zepp with a tuner.

**K7TQ:** Do you remember your first contest?

**NOUR:** Yes. My first contest was the 1967 Novice roundup. I just got on as often as I could. Sent in my score with no idea how I did. I was shocked to find out I won MN, first place in Dakota division, and ended up finishing 8th in the country. I ran out and bought my first QST. Did not do much contesting after that until I got radioactive/QRP about 10 years ago, I just started spending more and more time in the QRP ARCI contests, giving out the only MN multiplier in many cases. I just did better and better till now it is a full weekend, full effort.

**K7TQ:** There isn't a Novice Roundup anymore, which is too bad. I've heard many contest operators say that it was their starting place. FISTS tried to resurrect it a few years ago, but discontinued it from lack of sufficient interest. Perhaps the short duration QRP contests have taken its place as a training ground. With all those ARCI contests and QST contests do you have a favorite one?

**NOUR:** My favorite will have to be the Spring and Fall QRP ARCI contests. This is where I cut my contesting teeth. It is good to run into many familiar calls. Very competitive, but laid back at the same time; something for everyone. A close second is Sweepstakes CW; a real rush. I'm exhausted at the end of this one.

**K7TQ:** ARCI has two 24-hour contests and six sprints of 4-hour duration. Do you have a preference?

**NOUR:** Sprints are nice, but I prefer the 24-hour contests. Everyone should be able to find a few minutes to get on if they are not able to put in a full effort. I have no trouble sitting down in front of the radio for 8 to 10 hours straight. Wish I had a second bladder!

**K7TQ:** Eight to ten hours straight. Sounds like a key to scoring high. We've looked at some of your accomplishments, your station, and your contesting preferences. Now let's look a bit at how you operate in those contests. Do you make an operating plan, either mental or written, before a contest?

**NOUR:** I try not to set too many goals; just do the best with the conditions Mother Nature hands out. I do print out rate sheets from previous years to refer to and see what bands produced at which times, and see how my QSO rate is doing compared to previous years.

**K7TQ:** Reviewing last year's rate sheets sounds interesting. I'll keep that in mind. Reviewing yours will take longer than reviewing mine. During a contest I always have trouble deciding on a split between Search and Pounce (S&P) and CQing. What are your thoughts?

**NOUR:** This depends on the contest. In QRP contests I do much more CQing, 75%

CQ, and 25% S&P. In an ARRL contest it is about the opposite. I have to talk myself into hanging in there and CQ and not start tuning around when I am not getting any answers.

**K7TQ:** Let's say you've had a good run on 15 m, but it is starting to slow down. Do you have a rule of thumb for what to do when the contacts start getting far apart? For example, change bands, change frequency or slow the code speed down.

**NOUR:** That is the question! When to stay, and when to change bands or frequency. I find myself jumping from band to band more often later in the contest when things slow down. Hang in there during those slow hours, the 4 to 5 QSO per hour periods can make the difference; a new multiplier can make a big difference. For code speed, I don't like to push too fast. For me 22 to 24 wpm seems to work best.

**K7TQ:** Jim, earlier you mentioned that logging programs had eliminated most of the tedious jobs thereby making contesting more fun for you. From this I assume you use a logging program. There are several great ones out there. Which do you use?

**NOUR:** I use NA. A wonderful program, rock solid and easy learning curve. It also supports QRP ARCI contests. It does send CW, and my radio is interfaced for logging and band switching. I let it send CQ for me, but I send exchanges usually by hand. I like to say hello and thank you to my fellow contesters. Another great feature is knowing what your exact score is at all times, and watching it grow with new multipliers. I find myself setting new goals as I go, a break at 200 Qs, a beer at 100,000 points, another beer at 100,000 points, etc. Push a key when the contest is over, score and files are ready to be sent in.

**K7TQ:** The last contest operating technique question I've got for you, Jim, is whether you've used two radios in a contest, either dueling radios or a second one "hot" and ready to go?

**NOUR:** I started using two radios during Sweepstakes a few years ago. It can be very effective CQing with one and S&P'ing with the other. I only use two radios during QRP ARCI contests late in the contest when things really slow down. After 16 hours of one radio in one ear, and one in the other I will start to overload. I will grab the wrong knob and start tuning around the radio sending CQ. I also do not use any filters. I like my radio wide open. I hear stations all over the place calling me during QRP contests, [www.qrparci.org/](http://www.qrparci.org/)



which I would never hear with a narrow filter. With a radio in each ear there can be a lot of signals bouncing around in my head. I think it would near impossible to place in the top 10 in Sweepstakes with just one radio. I would like to see a one radio only class, it's not fair to the poor guy banging away with just one radio.

**K7TQ:** Let's shift gears a bit and talk about some of your "away from home" or field contesting. Many two radio club stations don't come close to your 632 contacts during Field Day. Tell us about your 2000 Field Day (FD) operation.

**NOUR:** I know FD is not really a "contest", but I look at it as one. My setup was pretty basic, just lots of wire down on my parent's farm in southern MN. I S&P the first half of FD, and do much more CQing on Sunday. I keep an ear on 10 and 15. I don't even try SSB till Sunday then work the easy ones, and get back on CW as soon as I can't find any more easy ones, and can QSY. The contest seems to start very slow. During the first two hours the rates are the lowest.

**K7TQ:** You've had some other interesting "Field Day" type operations. One that comes to my mind was 1998 QRP To The Field. The theme was "Run to the Borders" which encouraged operating from state borders. You and Larry, KB0R, operated from the MN, SD, and ND border in a farmer's field. As I recall your van got stuck in the field because it rained much of the contest. You guys had to get pulled out with his tractor. You wrote a very interesting story to QRP-L about it. (April 26, 1998) What do you have to say for yourself?

**NOUR:** I love getting out in the field.  
*The QRP Quarterly*

Seems like something interesting always happens. Dig out your copy of June 1992 QRP Quarterly; that is me on the cover. This was my first QRP expedition. I went out to Ransom, ND for the Spring QSO Party. I froze! The temps dropped below zero and I was not very well prepared. Not much fun at the time, but looking back it was great. The locals were great.

**K7TQ:** Great tale, Jim! Let's wrap this up with a final question. You regularly finish in the top 10. What advice do you have for operators that want to move into the Top 10.

**NOUR:** Make a commitment to operate the full 24 hours, hang in there during the slow times, keep moving and make noise. They can't hear you if you're just listening. Another good idea is to join a team. I feel pressure to produce and keep up my part as a team member (Bob, N4BP can really get tough if I start slacking off).

Thanks Jim, NOUR, for the discussion. I picked up a few pointers and I hope you readers did too. ●●

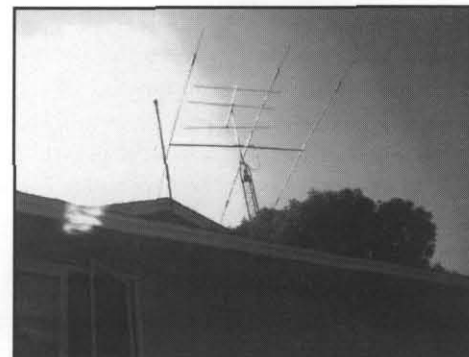

*The NOUR Antenna Farm*

# QRP? Which Kit to Buy? Yes!

Mike Boatright—KO4WX

ko4wx@mindspring.com

At a recent meeting of the North Georgia QRP Club (<http://www.nogaqrp.org>), the question, "Which kit should I buy?" came up. This question also pops up on the QRP-L reflector every so often. With so many great kits on the market, it really a difficult choice, sometimes, deciding what your first homebrew project from a kit should be.

Well, my answer is: Yes! I firmly believe that with sufficient time, energy, elmering, etc., you can have fun with just about any kit available today. Heck, the folks that put the kit together had fun, why shouldn't you?

However—and it's a BIG however—there are some kits that are better suited for the ham just getting started in construction than others. You might not want to bite off more than you can chew right at first. A very telling example of that is the partially completed White Mountain 75M transceiver from Small Wonders Labs (<http://www.smallwonderlabs.com/>) that's still sitting in a project box in my shack. I bought it a several years and many projects ago, and while the kit was extremely well documented, and fairly straightforward construction, I quickly found myself over my head trying to figure out what I had done wrong to cause no audio to come out.

On the other hand, there are some extremely small and/or simple projects, such as the Pixie 2 transceiver, that are very easy to construct, but very challenging to use. Build one of these as your first project, and you might get frustrated wondering why you can't get anyone to answer your CQ.

Please, please, please! Do not take these comments as being in any way negative about the kits themselves—it's all got to do with where you are in terms of your skill in construction and in operating. The key here is to have fun! And in time, you should plan to build both (in fact, I've built several Pixies, some that have worked and some that haven't, but each has been a blast to build!).

"So," you say, "what do you really recommend for the average ham, just getting started in construction?" Well, two of my favorites are the MFJ Cub (MFJ-93xxK) and the Small Wonders Labs SW-series. And to be more specific, I'd recommend either the MFJ-9340 or the Small Wonders Labs SW-40+.

Why? Well, first of all, in terms of complexity, both are well within the construc-

tion capabilities of most hams. Secondly, I recommended the 40 meter versions, because once constructed, you can almost always find somebody to chat with on 40 meters, just about any time of day, and you can often find someone to chat with who is going to be comfortable going at just your CW speed (hint, if you're like me, and can't blister the bands with 35WPM, you don't really need to configure the lower 25 KHz of the band!!!).

Both projects also have excellent documentation. In the case of the SW-40+, in addition to the documentation that comes with the kit, there is a complete "Elmer 101" series available on the Internet (<http://www.qsl.net/kf4trd/faq.html>). This "course" is truly incredible! Not only does it walk you through construction, step-by-step, it also explains the theory behind the radio. The web page grew out of the "Elmer Project" whose objective was to provide a group learning experience, and to help those just getting started in construction to better understand how a common QRP transceiver works.

The MFJ Cub is a great first project, because although it is a reasonably complex circuit (at its core it is a superheterodyne transceiver) that takes advantage of surface-mount (SMT) circuitry, MFJ has taken care of the hard parts of construction by pre-installing many of the kit's SMT parts using robotic equipment! When you are finished, you've got

a pretty good radio that's not too difficult to operate for the average ham.

For the next couple of columns, we will be talking about building the MFJ Cub (MFJ-9340). Although this series of articles is not nearly as comprehensive as the Elmer 101, it should help you get started and to get your rig on the air. You can order the Cub from MFJ via <http://www.mfjenterprises.com/index.htm> directly, or buy it from an MFJ dealer. For more information about the Cub, check out the QRP ARCI Cub Project page at <http://www.qrparci.org/cub.html>.

## Let's Get Started!

The first thing that you do when your kit arrives is to do the "happy dance." Every ham knows how to do the "happy dance" (you know, what you do after you worked your first station on CW, or your first DX—you get the picture). And then, tell all your buddies that your Cub arrived (understand, this is not considered boasting—in fact, it is sort of a courtesy, giving them a "heads up" that questions are soon to follow!!!).

The most important thing that you can do to prepare for constructing your Cub is to RTFM (Read The Fine Manual). Actually, the Cub comes with two manuals: a construction manual and an operating manual. Read both. It is *very* important to become familiar with how the kit is assembled—before



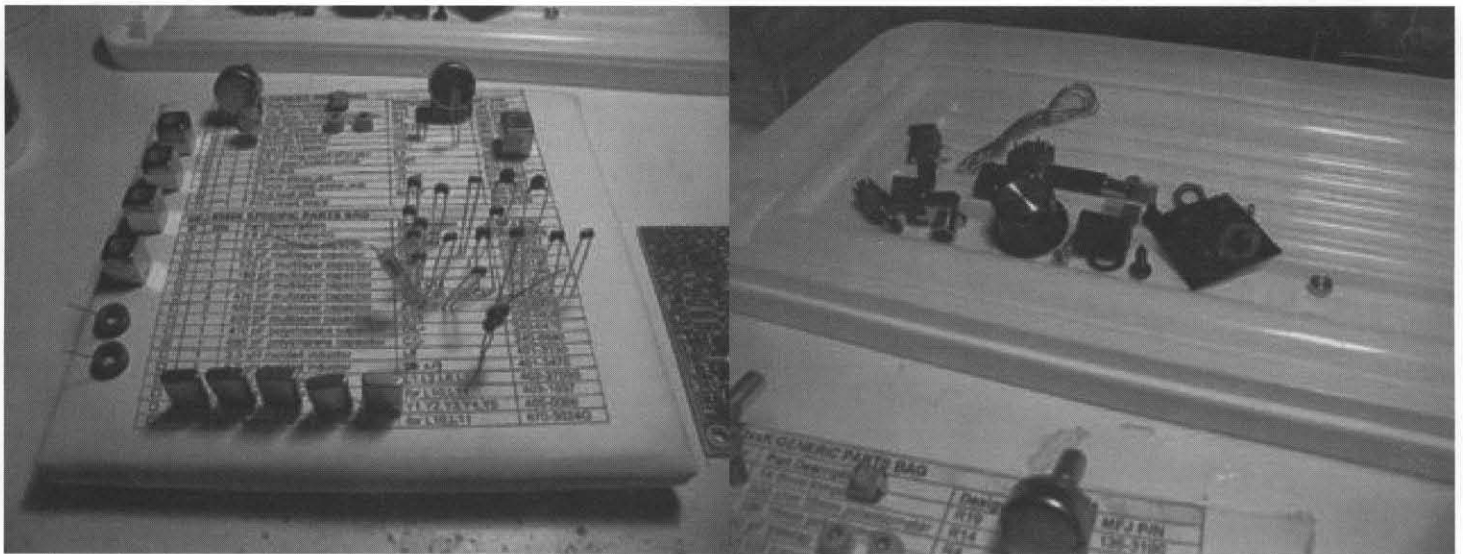

hands—and to begin to have some expectations about how it will operate once completed.

It is important, also, to have a clean, well-lit work area. It is a good idea, if possible, to not work over a carpeted floor. You would be surprised how impossible it is to find a small part that has been dropped onto carpet! Gather all of your tools and supplies, as described in the manual, then spread out the circuit board, parts bags, manuals, etc. from the MFJ Cub box.

Notice in the photograph that a piece of styrofoam has been added. While not required, I've found that if you photocopy the parts list from the manual and then tape it onto a piece of styrofoam, it makes the parts inventory much easier, and also aids in finding the right part during construction. Components can be easily pushed into the

styrofoam on or near their description in the parts list photocopy.

Following the instructions in the construction manual, inventory all parts—although MFJ has very high quality standards, sometimes mistakes do happen. What a way to put a real damper on your project if in the middle of construction you discover that you have stop and wait for a replacement part to arrive!

MFJ organizes the parts into three bags, a bag containing generic parts (same parts for every flavor of MFJ-93xxK), a bag containing the 40 meter specific parts, and a bag containing miscellaneous hardware. By the way, a plastic shoe box, available at most discount stores and drug stores, makes a very handy storage container to keep your project together during construction (assuming you don't build it all in one session, that is). The top can be

inverted to make a good place to keep loose hardware and parts together.

A word about soldering—this seems to be one of the most difficult aspects of construction when you are first starting out. The point behind soldering is to make a good mechanical as well as a good electrical connection. You also want to take care that you do not create any *solder bridges*. A solder bridge can occur when one of the leads touches another pad other than the one it is supposed to touch, and causes a short between the two pads. Too much solder, or touching more than one pad with the iron or the solder while soldering can also cause a solder bridge. More projects have not worked due to solder bridges than perhaps any other single cause! Go slowly, be careful, and inspect the board each time you solder a component and you will do just fine.

Next time, we will discuss the actual construction of your Cub, including tips on that great mystery, how to wind a toroid. Until then, lets get QRV! ●●

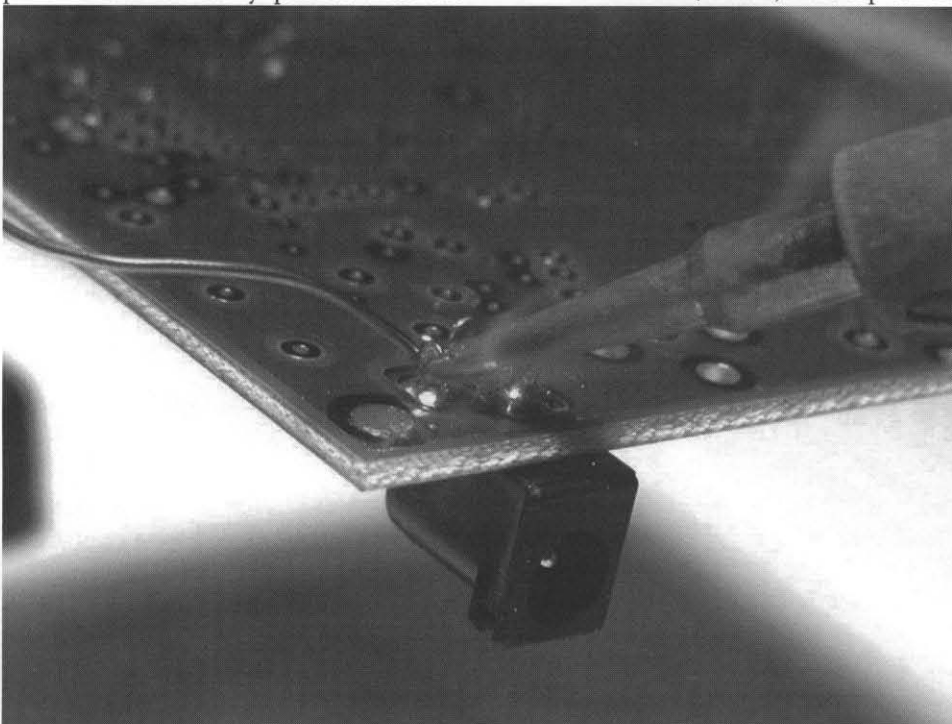

*Minnesota QRP Society's Mert—W0UFO & Jim—N0UR in the WQORP Chalet. They helped get high score despite computer not liking the cold, switching logging programs in the middle of the contest, and keyer problems. Antennas and deep cycle batteries did OK.*

# Adventures in Milliwatting—Shortened 80M Vertical

Jim Hale—kj5TF

kj5tf@madisoncounty.net

I never used the 80M band too much myself. I needed 3.560MHz for the Arkansas QRP Club's Monday evening net. So I built a 30% shortened 80M dipole. When I wanted to get a little more serious about longer range contacts on 80M I decided to try and build a vertical. None of the trees around were quite tall enough so I would use the BASIC program "Reducer" again. By cutting the size by a modest 30%, efficiency isn't reduced too much. I chose 3.570MHz as the half way point between the 3.560 QRP CW calling frequency, and the 3.580MHz psk31 frequency.

The program is for a dipole, and my vertical is only  $\frac{1}{4}$  wave, so I just use half of the information generated by the software. The "reduced total length" of 91.76 ft, and divided by 2 is only 45.88 ft. A 45.8 ft vertical would fit my trees just fine.

It worked out to look like this. A ————//——— B Where A. is the top or "stinger" of the vertical, and it's a piece of hookup wire 27.5ft long. The coil, shown as //, is solid copper house wire, 8 turns per inch, and 26.9 turns on a 2-inch diameter PVC form. The form is 7.3 inches long while the 17.84mH coil itself is only 3.36 inches long. The B section is 18.3 ft long hookup wire, and I have a SO-239 on the bottom where it's fed with RG-58u coax. Four  $\frac{1}{4}$  wave radials are raised 6 ft off the ground and strung in the brush and trees behind my house.

The B section runs about  $\frac{1}{3}$ rd up the tree, and the top of the stinger section just reaches the treetop. I trimmed the top end of the stinger to get 1.4 SWR.

One of the active AR QRP members, Ken K5ID told me that the top half of a vertical can be bent to near 90 degrees if the trees aren't tall enough, and it won't effect the pattern much. I didn't have to do that for 80M, but I'm trying his idea right now to fit a 160M vertical behind my house. The top half is bent at a 35 degree upward angle, but despite my best efforts to this date I can't get the SWR's below 2.0 for the QRP calling frequency of 1.810MHz. I'm going to keep trying.

Get a copy of Reducer and GWBASIC on my website downloads page. <http://www.madisoncounty.net/~kj5tf/>

## Shortened 30M Half Square

Another antenna I get a lot of use out of is my 30% shortened half square. A full sized 30M  $\frac{1}{4}$  wave vertical is about 23 ft. In my

front yard the trees aren't much taller, so the bottoms of my half square verticals nearly touched the ground, and were a navigational hazard. So I used the Reducer software and shortened the verticals 30%, so this time the bottoms are above head banging altitudes. The distance between the two verticals remains the same, as a non-shortened 30M half square,  $\frac{1}{2}$  wavelength.

For an added touch, I attached a 17M inverted vee dipole to the feed point, and it now I have two resonant antennas on one short length of RG-58u. VE3MFN and I set the current 17M miles per watt record, of 181,600 MPW, with my add on inverted vee dipole. With help from W8LGJ/QRP I added to that record again in January 2001 with 318,619 MPW on this add on inverted vee dipole.

## Mobile milliwatting

If you find yourself "along for the ride", with your XYL or OM and have to do some parking lot time, remember to bring along your QRP rig. In an hour's time, (or longer for those heavy shopping days) you might be amazed with what you can do with a few milliwatts. I have a plan for those afternoons, and I have a lot of fun for me most of the time. I load up my QRP+, and all the fixins in GI canvas bags, and my new PW-1 portable antenna. The PW-1 on my pick-up gives me 20-10M with near flat SWR's. For 30 & 40M I have my old hamsticks.

I used to bring along my WM-2 QRP wattmeter, but now I just use my old Vanco SWR-2, SWR, & wattmeter. I can set power at 250-500-750mW and feel it's pretty close to correct. I generally look for strong stns CQ'ing with no callers, but at times I try CQ'ing with 750mW.

This all started for me when I built my NorCal 49'er kit, in its Altoids tin. Running stock 250mW, I made contacts pretty easy on 40M using a 40M Hamstick.

I've had pretty good luck, and even met some of the ARCI, and QRP-L folks who know I am a milliwatt freak, and are willing to play QRP Limbo with me. During some of the CW contests, I've been able to work the big gun DX stns while parked, and running less than a watt. It's amazing to do any ham radio below 1 watt, but to get into  $\frac{1}{2}$ w,  $\frac{1}{4}$ w levels while parked in your car is something you must experience to appreciate.

## QRPp Internet list

A growing number of "Extreme QRP'ers", now at 24 have joined the Yahoo Group known as QRPp. They use this email list to keep each other informed in the latest events, band conditions for QRPp, and all aspects of our little corner of the hobby. Use the URL below to register and sign up for qrp. <http://groups.yahoo.com/>

## Mailbag

Hi Jim, Came across your writings on the list and just wanted to say that I was building a qrp rig (transceiver) that was supposed to have an output power of 4 to 5 watts but could only get 800 milliwatts with 12 volts. After finding now one that could give me info I decided to go the other way with the power. I'm now down to 200 milliwatts and making contacts, don't know what the real power to ant. is because of losses, reads 200 milliwatts with 50 ohm dummy load and reads 150 milliwatts with the ant. hook up. Still working my way down the milliwatt ladder. 73's GARY KB2PQE

**From George Osier, N2JNZ/QRPp**  
DXCC QRPp: 56 WORKED, 18 CFMD

W.A.C. QRPp: just sent in...700 mw and under!!

AFRICA: TZ6DX 90 mw  
ASIA: JH0ZHQ 700 mw  
EUROPE: ES1QD 50 mw  
SOUTH AMERICA: PY2EDY 500 mw  
OCEANIA: VK4XA 700 mw  
NORTH AMERICA: KL9A 700 mw

## BEST MILES PER WATT:

OK/OM3BH...4 MW...4109 MILES...10 METER CW  
1,027,300 M.P.W.

Worked Rasto, OM3BH at his friends station OK2RZ before the 2000 CQ WW CW on 11/24/00 at 1422 UTC...he heard me on a VERY impressive antenna farm! Worked me with three 6-element yagis in phase! ●●



# QRP ARCI Awards

Thom Durfee—WI8W

wi8w@arrl.net

So here we are in the middle of winter (Feb 15) and your new Awards Manager has been hard at work moving into a new house and unpacking all the stuff for doing awards sent to me by our past manager Steve N4EUK. Boy do I hate moving.

First, let me say a big thank you to Steve for his dedication and hard work over the last few years as the Awards Manager and for his efforts in getting all that stuff to me in a efficient and timely manner. Thanks also for the phone conversations getting me all fired up to do this project. We all owe him a thanks.

On to the business at hand. Presently I have just finished up the backlog of award applications received since December 15 and those awards will be going out in the mail early next week.

## Here is the breakdown:

1,000 Mile Per Watt:	22
DXCC:	1
WAC :	2
WAS:	5
QRP25:	2

Looks like I need to order some more certificates for that 1000 Mile award!

When filling out an application, please make every effort to fill it out as completely as possible. If you have an email address, please include it on your application in case I have

any questions about your request. If you do not have an email address, please include your phone number, or another way to contact you.

As you may already be aware, the Board of QRP/ARCI approved a fee increase effective January 1, 2001. Fees for all awards increased to \$4 for each certificate for US and Canadian stations and \$5 for each certificate for Foreign Stations. US Funds Only, IRC's accepted only from Foreign stations. You may pay by check or money order with PayPal as an option for those that care to use that service. Please make checks payable to QRP/ARCI Awards Program. QRP/ARCI and Thom Durfee are also acceptable.

Looking at the records for all the awards I find it interesting that we have issued awards of various kinds, for every conceivable mode and band, from 160 meters to 10 Gigahertz. There is one interesting hole however. We have never issued an award for the 440 Mhz band. Surely someone has accomplished a QRP QSO or two on that band. Maybe you could be the first?

We have issued only 1 QRP RTTY WAS award, in 1993. Anyone want to be #2? How about PSK WAS? You can still be #1 on that mode. Remember you only need 20 states to qualify. How about PSK DXCC?

If QRP ARCI approves, I am planning to issue award certificates at FDIM in Dayton this year. To my knowledge this has never

been done before and I am planning on offering a special endorsement for any award issued during the event. If you want your certificate issued at FDIM, you must present your documentation in person (hey this is a fun event after all) and please let me know, if you can, in advance that you will be taking advantage of that offer. Drop me an email or a postcard with your request.

I am not sure if I will be able to issue awards at the Dayton Hamvention. It all depends on if the booth the QRP/ARCI would be big enough to accommodate the activity. Of course approval would be required. I will post updates to this project on the QRP-L mail list and on the forum at <http://www.qrparci.org>

The new award applications (there are 2 of them) are just out and if you need a new one you can probably get it from the club website at <http://www.qrparci.org> or you can write to me with a SASE and I will mail them to you. You can also get them if you send me an email at [wi8w@arrl.net](mailto:wi8w@arrl.net) and I will send them back to you as attachments. The documents are in Word format.

Finally, I have some ideas for new awards, do you have any? Please drop me a line with your ideas.

That's all for now. Happy hunting and good DX. Till next time, 73 ●●

## New Product Announcement

# KK7B R2Pro Receiver Module Kit

Kanga US has added the KK7B R2Pro Receiver Module kit to its line of products.

The KK7B R2 receiver circuit was originally published in 1992. Advances in components and techniques, and improved understanding of the underlying principles now permit a few improvements to be made. The R2pro remains true to the philosophy of the original R2—a basic, all-analog, high-dynamic range, very low audio distortion receiver module using commonly available components. A conservative approach to circuit modifications preserves the performance and character of the original R2 receiver. The changes are as follows:

1. The receiver is separated onto a number of smaller circuit boards. This improves RF and audio isolation, allows optimum grounding for both RF and audio circuitry, and provides flexibility.

[www.qrparci.org/](http://www.qrparci.org/)

2. The gain distribution includes an RF LNA, lowering basic system noise figure to 10 dB while preserving dynamic range.

3. Mixers have been changed to the TUF-1 series. Improved mixer specs and LNA reverse isolation reduce the LO level at the antenna connector to typically less than -90 dBm.

4. The diplexer network pair has been redesigned for better amplitude and phase match, and lower group delay.

5. Reduced interaction between mixer IF port impedances and diplexer networks allows the R2pro to provide more than 50 dB opposite sideband suppression, when built with carefully matched components.

6. In-band audio harmonic distortion in the original R2 was approximately 60 dB down. R2pro harmonic distortion products are below the receiver noise floor, more than 80 dB

below either of the two tones in multitone in-band distortion tests.

The original R2 set the standard for low distortion audio in receivers. The R2pro offers advanced experimenters even lower distortion, lower noise figure, improved opposite sideband suppression & more flexibility.

Pricing is being determined as this announcement is being written. A kit will be available at the Dayton Hamvention. Other Modules designed by KK7B are available from Kanga US including the R1, T2, LM2, and miniR2.

## Kanga US

3521 Spring Lake Drive

Findlay, OH 45840

419-423-4604

[kanga@bright.net](mailto:kanga@bright.net)

[www.bright.net/~kanga/kanga/](http://www.bright.net/~kanga/kanga/)

The QRP Quarterly

April 01 47

# Remember When

Les Shattuck—K4NK

k4nk@aol.com

It is 2001...do you know what that means? The QRP ARCI is 40 years old. The original club was started by Harry Blomquist—K6JSS in 1961. Boy how time flies when you are having fun. Let's compare things from then and now, well we might as well add some notes from 1981 the mid point as well. Any way the original club had a main goal of lowering power in your rig to 100 watts or less. A far cry from our present 5-watt organization. But at that time most hams ran rigs that were 100 watts or less. What was Harry and company's thinking then? It seemed he was upset with the "California kilowatts" which were becoming popular out on the west coast. In 1961 receiver selectivity was not a common feature, in fact a lot of novices used old Hallicrafters S-38's for the station receiver. They worked fine if everybody ran 25 watts or so but you could hear a KW station all over your dial. Little did Harry know what the club would be come 40 years later—most all the rigs on the market are able to have



From left to right—Bryce(W9PNE) Jim Sterns (KK7C), "Red" Reynolds (K5VOL), Chris Page (G4BUE) at Dayton in 1985. Looks like Bryce got stuck with the bill.

bandwidths of several hundred hertz.

By 1981, some 20 years later club president, Thom Davis—K8IF, had succeeded in taking the club to the 5-watt level and most operators who were really active began to use the 5-watt or less out puts. Yes, there were still some who thought the 100-watt rule was just fine and these 5-watt nuts probably would not work anybody anyway. But as I look at page 3 of the April 1981 quarterly, I see a picture of Bill Dickerson—WA2JOC with his QRP DXCC trophy number 10. Was this a sign of things to come? Would these " little guys " work the world with 5 watts or less...we all know the answer. And what we think of as QRP was off and running. Dayton...yes, Dayton Ham Fest and QRP were on track in 1981 a little paragraph in the Quarterly told of the QRP forum held in room 3 on April 25, 1981 at 8:45 am and that a QRP hospitality room, number 167 at the Ramada Inn. The guest speaker—who else Ade Weiss,

WORSP. Hey...I was there, and it was great!

Well it's 2001...we all know about how QRP ARCI has changed and grown. What started with a few fellows who wanted to clean up the bands, to thousands who love to build and operate our small rig's. From a Dayton show with about 25 QRPer's in attendance to FDIAM where hundreds show up and a full house is a fact. It over whelms me to think of it. What will the next 20 years bring, what new rigs will grace our operating benches? It all boils down to this, we are a dedicated group of Amateur Radio Operators who enjoy having fun and finding new ways to do it. OK, next issue will really be a big one, I'm bringing out the pictures and every one will see what you looked like 20 or more years ago. Ha! Did you know Danny even had hair once? Yes and...oh well, better keep it a secret see you in the next issue... ●●



1983—Les (K4NK), acting QRP ARCI President, with Vice President Jim Fitton (W1FMR) in Salsbury, New Hampshire. Jim became next President.

## FYBO 2001 Results—MULTI-OP CLASS

CALL	QSO'S	SCORE	REMARKS
WQ0RP	225	464400	OPS: AA0ZZ, K0PC, KB0R, N0AR, N0UR, W0UFO, N0HRL
N1BQ	84	129024	N. Vermont QRP Society OPS: KM1Z, N1BQ, KK1J, KB1EZD, KB1EZC
AC6KW	87	121104	OPS: KQ6DV, K6EXT, AC6KW, KF6QI
N8KV	45	49680	OPS: N8KV, KX8CW, N8BRI, KC8LTL
NQ4RP	43	30272	NOGA QRP CLUB OPS: K4JTD, AD4S, AD4J
K8JV	21	13440	Isaac Walton Portable Radio Operators Club OPS: K8JV, K8TRE, AA8UU
KR6LP	21	11760	Lake Perris QRP Society OPS: K6WHP, K6BNC, AD6HR
K8UO (40m)	26	8736	OPS: WB8E, W8EDX
W6MV	32	8704	OPS: W6OQX, AD6GP, AD6EZ, KE6WYA, KM6JE
K8UO (10m)	30	7200	OPS: WY8M, KC8QEG

## Profiles in QRP

Rich Arland—K7SZ

rarland@earthlink.net

This installment of Profiles in QRP features an interview with Les Shattuck, K4NK, a long time QRP ARCI member, former Club Officer and BoD member, ARRL Roanoke Division Vice Director and big time QRP DXer. Originally licensed when he was only 15 years old, in 1963 as WN2IPX, Les has held the following calls: WB2IPX, WN2V and currently, K4NK. He first joined the QRP ARCI in 1978 (#4152) and has been active ever since. He has served as QRP ARCI Vice President and President and has been on the Board of Directors several times. He currently writes the Club House column for the QRP Quarterly and is the official Club Historian. In 1983 Les received the coveted QRP DXCC Milliwatt trophy (#61) from by Ade Weiss, W0RSP, for completing DXCC using less than one watt. Additionally, he holds the QRP Masters Award from the G-QRP-Club.

**QQ:** First of all, Les, let me say a very big "Thank You" for this interview. We've know each other for about 20 years or so, what's going on in K4NK's world today?

**K4NK:** I'm busier today than I have been any other time in my life. Your phone call caught me just after I'd returned from church services where I preached the sermon. I graduate in May and will then be ordained as a United Methodist minister. From there, it's on to graduate school at the seminary. In addition, my duties as Vice Director of the Roanoke Division of the ARRL keep me hoppin'.

**QQ:** You sound busy! Any time left over to get on the air?

**K4NK:** Sure, but not nearly as often as I'd like. I still manage to hang out on 14060 kHz looking for QRP DX, plus work some of the QRP sprint-type contests as well as the Spring and Fall QRP ARCI QSO Parties.

**QQ:** Not many people know this, Les, but I remember you saying that you were around the 300 mark on DXCC countries using 5 watts or less. What are your current DXCC totals?

**K4NK:** My current totals using 5 watts or less are 316 worked and only 302 confirmed. I'm close to the Honor Roll, but not there yet. About the only real DXing I do is for the occasional new country. My main interest in QRP operation now days is work-

ing DXCC using two way QRP. I believe I have the most G-QRP-C members worked (over 300) on 20 meters from the States.

**QQ:** What is your favorite band and mode?

**K4NK:** Twenty meters, without question is my favorite band. CW is my favorite mode, although I do some SSB work. The split is about 95% CW and 5% phone.

**QQ:** Your DXCC totals and the certificates from the various contests you've won are impressive, Les. Any tips you'd care to share with our readers?

**K4NK:** Absolutely! First, use the best receiver you can lay your hands on. The old adage "You can work 'em if you can't hear 'em" is true. A good receiver with good IF filtration is a must.

**QQ:** Speaking of filtration, do you use any DSP filters?

**K4NK:** Nope. I've found, after years of training, that the best "DSP" filter is your brain. Anyone who desires to become anything but an average CW operator must learn to remove all distractions when copying code. This comes with experience and training your ears to hear the weak ones. There is no magic here, just concentration, experience and lots and lots of time at the radio.

**QQ:** Tip number two?

**K4NK:** You don't have to use a large directional antenna, but it helps! My second tip is to erect the best antenna, as high as you can at your location. If you cannot put up a beam or quad, then work something out with wires. Wire antennas work and they work very well. For the majority of my ham radio lifetime I used either wire dipoles or loops and a small TA-33JR triband yagi. These antennas were never over 35 feet up but they allowed me to work my fair share of DX and contest effectively.

**QQ:** It seems that CW is the preferred mode in QRP, any advice there?

**K4NK:** Sure. Although I can copy at 40 WPM +, I find that the majority of my CW contacts are done at between 18 and 20 WPM. This sounds extremely fast to folks who don't feel comfortable with CW and have never really tried serious CW operation. However, the 18-20 WPM speed range is easily reached with practice. Enter every CW contest you can. Get in front of the radio and get on the air. Contest, especially, build QRP operating skills. Better skills mean better op-

erators. Contest also are great places for finding DX and boosting DXCC totals. If you have under 100 countries, work all the contests you can and you'll be astounded how fast your country totals climb.

**QQ:** Since you are a serious DXer how do you keep abreast of developments and DXpeditions?

**K4NK:** Well, I don't do much "straight DXing" any more, nor do I chase DXpeditions, unless they are a new country for me. However, I do have several sources of DX information that I rely upon. First is the ARRL DX Bulletins that you can get via e-mail every week. N4AA who publishes QRZ DX is a good friend of mine and I get his newsheet regularly. Finally there is the 455 Group from Italy and I am on their list to receive their publication. Between all those sources I keep in touch with the DX scene.

**QQ:** Speaking of DXpeditions, any thoughts on improvements that could be made?

**K4NK:** Yes. Since QRP is the fastest growing facet our ham radio hobby, and the word is definitely out about that, I don't see why DXpeditions couldn't accommodate the QRP fraternity by taking some operating time each day and reducing their power and work nothing by QRP stations. This would be a great way to offer two way QRP contacts with extremely rare DXCC countries and it would promote the QRP side of the hobby at the same time.

**QQ:** How about QSLing. Any tips?

**K4NK:** Well, after 10,000 or so QSL cards received, I don't actively QSL any more. If a station needs my card, I QSL direct. If I work a new country or a two way DX QRP contact, I also QSL direct and include either IRCs or mint stamps from the other station's country.

**QQ:** I know you are on the road a lot. Do you take a rig along?

**K4NK:** Absolutely. I have a small portable station consisting of a Ten-Tec Argonaut Scout (model 556), a home brew antenna tuner and tuned dipoles for each band. I have a "secret source" for gel cell batteries and I have one or two gel cells and a solar charger, too. This rig gives me the option of CW and phone in a small package.

**QQ:** I gotta ask. What's your "secret source" for gel cell batteries?

**K4NK:** Well, don't pass this around, but

hospitals in my state of South Carolina are required, by law, to replace all their emergency lighting batteries every year. So, I struck a deal with the local hospital to take all their throw aways. Consequently I have a room full of good gel cell batteries that I use for portable work.

**QQ:** Great tip. I won't tell a soul. What do you see for the future of QRP?

**K4NK:** The greatest thing to come along in the last several years is PSK-31. I really think that this digital mode or something like it with revolutionize ham radio and thrust QRP into the limelight. With only a couple of watts you can work the world using a digital mode with real-time keyboard to keyboard QSOs. The

price tag is minimal and it is tremendous fun. CW will become less prevalent due to the changes in licensing, world wide. Sad but true, I think.

**QQ:** Any last comments for our readers?

**K4NK:** Yes. QRP is the greatest part of the ham radio hobby. It's fun, challenging and unbelievably rewarding. Good QRP operating procedures are just as important to our hobby as homebrew construction. I'd personally like to see much more QRP operating going on. Although the Fox Hunts are great, little activity takes place after the hunt is over. How about keeping the rig on and working a few more Qs. Remember that experience

makes better operators and you don't get experience reading QRP articles or building radios.

**QQ:** My thanks to Les Shattuck, K4NK, for taking the time out of his busy schedule to do this interview. One parting thought: Those of you who are serious about DXCC, Les is working behind the scenes at the League to lead the fight for a QRP endorsement to the League's DXCC certificate. Don't let him do all the work. Write, call and/or e-mail your Division Directors, Section Managers and the DXCC folks at the League. Let them hear our collective voice. That's the sure way to effect change. ●●

## Test Topics and More #7

Joe Everhart—N2CX

n2cx@voicenet.com

### Coming To Terms

The last column promised that we would continue with the weak signal source in this installment. Unfortunately other commitments have made this impossible. I really want to have the project completed and checked out before describing it further. Pride keeps me from portraying an incomplete project as one that is finished.

Instead, let's look at a simple circuit that I have built up at least a half dozen times over the last 20 years.

A couple of columns ago DFT presented a crystal oscillator with a calibrated output level and low distortion. But quite often I need to either check a crystal or generate a known-frequency signal and really don't care about its wave shape or precise level. **Fig. 1** is the schematic diagram of what I call a "crystal colpitts" circuit. It's very non-critical and can be "whomped up" Manhattan-style in about 10 minutes. It needs no fancy power supply or crystal socket. Simply used a 9-volt battery connector and turn it on and off by connecting or disconnecting the battery. And a couple of short leads with minigator clips allow you to connect to any style quartz crystal. As shown

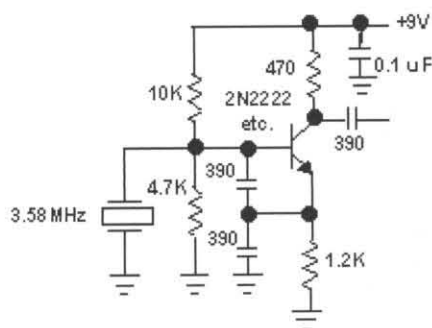

Fig. 1—3.58 MHz crystal oscillator

it oscillates close to the series-resonant frequency of the crystal. To warp it higher connect a trimmer cap between the crystal and ground.

As shown, it is a very handy test signal source for checking out a receiver on the 80-meter color burst frequency such as the PSK-80 Warbler described later in this month's column. Simply check its frequency by connection a counter to the output lead then connect the output to the Warbler input via a 10K or higher resistor. Presto – one strong signal source that can be used for checking and setting the Warbler receive frequency.

A future installment will describe some simple additions to the basic oscillator to extend its utility as was presented several years ago in the CQRP "Low Down."

### Coming To Terms

This time around Coming To Terms doesn't describe a test term per se but a feature of modern electronics that you just may encounter when troubleshooting. Most commercial products and even many simple kits are built on printed circuit boards these days. They simplify construction by providing a ready-made base for mounting and interconnecting electronic components. And if carefully designed they make sure that lead lengths and component placement are controlled in critical RF projects.

As you doubtless know they consist of copper traces deposited on a thin non-conductive board, usually a very stable glass-epoxy composite. Familiar components are mounted by having their leads pass through holes drilled or punched in the boards. Interconnecting traces interface to the component

leads via enlarged pads that encircle the holes providing where the component leads are soldered in place. Simple pc boards use traces only on the bottom or "non-component" surface of the board.

As boards get increasingly complicated, though, there is not enough room on the bottom side for all connections so double-sided boards are used to add additional traces on the topside as well. Topside traces also handle surface-mount parts and leads that topologically need to cross over others without electrical connection. You can see, then that there is a need to interconnect some top and bottom traces.

This could be done by using pads on both the top and bottom of the board around a hole then running a lead trough the hole and soldering it on both surfaces.

However a modern technique handles the interconnection more simply. Instead of relying on a lead through each interconnected hole, pc board manufactures make top and bottom traces but make their own top and bottom interconnections. They do this by making top and bottom traces then drilling or punching holes through the board then metal-plating the insides of the holes! Logically these are called plated-through holes (PTH). The same PTH also served as component lead holes where needed. **Fig. 2** illustrates a PTH that interconnects top and bottom copper while accepting a component lead. Though not too common in simple pc boards these PTH can also be used to interconnect "buried" layers in multi-layer boards such as the motherboard in your modern personal computer.

PTH are very handy items that make pc

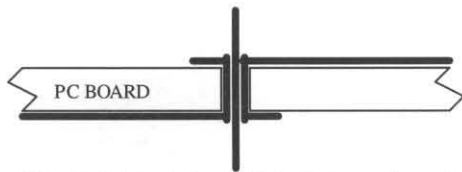

**Fig. 2—Plated-through hole in pc board** board convenient to design and build. However they can cause problems, as we shall see shortly.

### Stimulus and Response

A common theme that underlies quite a few questions I receive is “how do you troubleshoot?” to be honest I prefer to use as much test equipment as I can to make the job simpler. It’s like solving a mystery – and like a detective a troubleshooter has to unearth as many clues as possible. Using a variety of test instruments in this case is the same idea as a crime lab using a battery of forensic tests to uncover evidence.

But this isn’t always possible in Joe Ham’s garage workshop. With this in mind I’d like to describe some real-life troubleshooting I recently had to do in which I intentionally used as little fancy test equipment as I could. So that this column doesn’t usurp the whole Quarterly issue I’ll describe only some receiver troubleshooting now. Perhaps a future column will go into the transmitter.

This rig is a very simple PSK-31 transceiver designed by NN1G for 80-meter use (Ref 2,3). The clever design is a full direct conversion transceiver using little more than a handful of parts but offering very sophisticated processing. A block diagram in Fig. 3 shows the receiver portion. Input signals from the antenna pass through a transmit/receive switch and are buffered by a simple RF amplifier. Next they pass through a simple crystal filter that passes only 3.579 to 3.580 MHz. A crystal oscillator in the transmitter chain is also used by the receiver as a local oscillator. It feeds a mixer that beats the signal down to audio. Its frequency is offset to the high side of the crystal filter so only signals below the oscillator frequency are passed. Yes, it’s a direct conversion SSB receiver with a crystal filter! Finally the audio is amplified before being fed to the audio input of a computer’s sound card. An output switch mutes the audio output during transmission to prevent disrupting the sound card operation.

I had been working on one of the prototype warblers and found that it intermittently

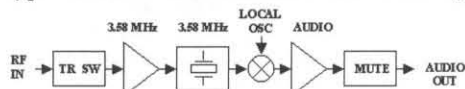

Figure 3 - Warbler Receiver Block Diagram

had very poor sensitivity. At times it received fine but every once in a while it became extremely deaf. The PSK-31 software Digipan (Ref 3) gives a good visual indication of received signals as shown in Fig. 4. However with no signal the display is nearly blank as depicted in Fig. 5.

The first test was to measure DC voltages in the receive chain as indicated in the Warbler manual. It “seemed” that I could get good readings (more about that later) most of the time.

Lacking an 80-meter signal generator I noted that simply touching the metal crystal cans in the crystal filter

with a finger gave me receive signals in amongst a lot of digital hash from my computer! See Fig. 6. But when I touched the antenna input, I one more noted no signal. Similarly touching the input to the RF amplifier resulted in signals passing through. But

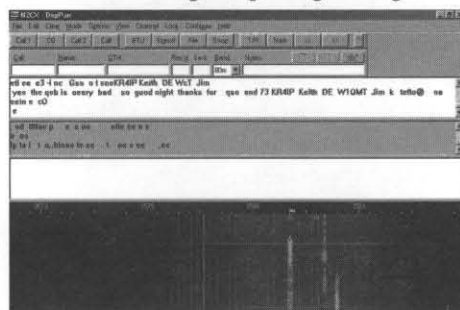

Fig. 4

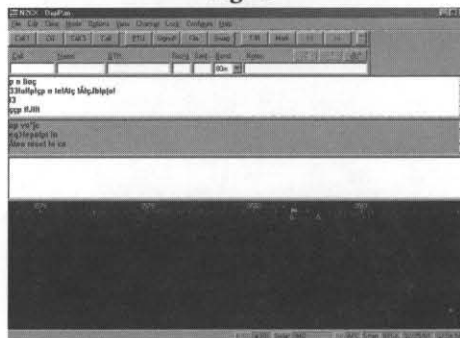

Fig. 5

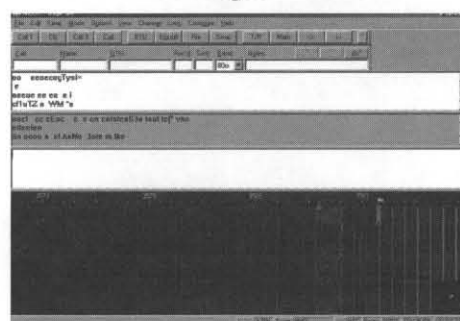

Fig. 6

nothing came though the TR switch most of the time. Once or twice, though, when I probed the TR switch traces with a metal probe, reception seemed normal.

This was very frustrating and humbling!

It was obvious that something in the TR switch was breaking the signal path – most of the time. One obvious thing to try was to check continuity of the signal path with an ohmmeter and wiggle things to look for loose components or broken pc traces. Results were inconsistent. When I lightly probed with the ohmmeter, there was intermittent continuity but when I pressed the ohmmeter probe hard on the traces, the traces seemed to show low resistance.

Finally inspiration hit – plated through holes on the TR switch components were used to connect traces on top of the board with those underneath. I had been changing some of those components and might have damaged a PTH. Sure enough, I found one that, when probed lightly had high resistance between the top and bottom traces, but wiggling the lead or probing hard made the connection. The component lead was soldered on the bottom of the board but not the top. And the component removal and replacement had damaged the PTH so it did not make a solid connection with the top trace. Continuity was solidly restored by simply soldering the component lead to the trace on the board topside.

Figure 7 shows how a damaged PTH disrupts continuity before repair is made.

Ah, did this fix things? NO! The receiver



Fig. 7—Damaged PTH

still did not get any signal through its TR switch and overall continuity had not been re-established. OK dummy, if you fouled up one PTH could you have botched another? Sure enough one additional PTH in the input to the RF amplifier was designed to connect top and bottom traces and there was not a solid connection. Once again soldering the component lead on top as well as below the board fixed the problem. Problem solved, the receiver is now solid!

OK, that’s it for now. Next time we should be back on track with the weak signal source!

Ref. 1—N2CX, “VXO Crystal Checker,” “The Low Down,” August 1996, pp 15-19. Ref. 2—“The PSK-80 Warbler” instruction manual by NJQRP available on-line at: [www.njqrp.org/warbler/index.html](http://www.njqrp.org/warbler/index.html). Ref. 3—NN1G and N2APB “The Warbler – A Simple PSK31 Transceiver for 80 Meters,” QST, March 2001, pp. 37-4. Ref. 4—Digipan software available from Skip Teller KH6TY/4 at:

<http://members.home.com/hteller/digipan/> ●●

# Out in the Cold with the Cheeseheads

Craig W. Behrens—NM4T

craigwb@hiwaay.net

## April 2000 QRPTTF:

A bunch of the QRP Cheeseheads group ventured out to the western shores of Lake Michigan where it was in the mid 40s with about a 20 mph wind. It was COLD! However, after doing FYBO in February, how bad could it be, right? The crew consisted of AE9K, N9AW, NK9G, W9XU, WA9TZE and KF0CT. We decided to each use our own calls to maximize activity for us and for all of you that participated. We shifted operators on three primary rigs every 30 minutes so everyone got their chance. We used two FT900s and two Argo 515s. On hand were a Wilderness Sierra and a home-brewed 40-mtr Ramsey receiver/transmitter combination. Oh, and gaggle of batteries which we all agreed we need to trim down for the next event...those babies are heavy.

We got off to a little later start than we wanted to and the wind contributed to our delay. NK9G, our resident archer, had a tough time getting the lines shot into the trees with the wind and all but finally overcame that obstacle. For antennas we had a 20-mtr delta loop and a 15-mtr delta loop, points hanging down, both suspended on the same rope about 50 feet high. The other antenna was a G5RV at about 40 ft.

Conditions on 20 and 15 were excellent. In fact, I would say 15 was in great shape for what is essentially a stateside contest. I couldn't believe the activity on 15 compared to just 2 weeks prior in the ARCI Spring QSO

Party where all I could work was a few on the left coast. 40-mtrs usually is a good band for us here in the Midwest also but this time it was not so good. It's tough to tell if it was just propagation or the broken antenna lead at the center insulator we found with about 1.5 hrs to go in the contest. From what others have said it doesn't sound like we missed much on 40 though. Essentially, we were using one half of a short 40-10 meter G5RV, so that's about 26 feet of wire. The MFJ tuner did its job to tune it out with our 40-mtr station on one of the Argo 515s. With about 1.5

hrs remaining in the contest we decided to move 40-mtrs to one of the FT900s. When the 900 couldn't tune out the SWR we knew we had more than just a bad propagation problem. Without any soldering capabilities we just made the best mechanical connection we could and went for it. Activity on 40 should have picked up after that.

I really enjoyed myself despite the cold weather. It was fun being out with my QRP buddies and it was fun working so many stations that made the effort to get out into the field. Your enthusiasm is contagious...keep it up.

## Jerry—N9AW and Rick—NK9G FYBO Summary:

FYBO sure was fun again this year. Thanks to the AZ ScQRPions for hosting the contest.

It was, again, fairly cold on Saturday morning. Just 14 degrees at the start. It warmed to about 23 degrees and stayed there most of the day. NK9G



From left to right: Jim—WA9TZE, Lon—W9XU, Jerry—N9AW, Brian—AE9K and Rick—NK9G.



Jim—W9TZE



Rick—NK9G



Lon—W9XU



Brian—AE9K



Chuck—KF0CT



Jerry—N9AW

and I worked the contest from a campground in Plymouth, WI. about 60 miles north of Milwaukee. We put up 3 antennas...a G5RV in inverted-vee fashion about 40-50 ft., an 80-10 trapped dipole at about 40 feet and a DK9SQ 40-10 loop on a DK9SQ mast. Without question, the trapped dipole was best, closely followed by the G5RV. The DK9SQ loop was OK but showed a 3 S-unit decrease in most signals on 15 and 20 meters. This was the first time I used the loop and I was disappointed. I think it probably has a lot to do with the fact that it is a compromise antenna for multiple bands with a feed point that is only up about 15 feet off the ground. When compared to the height of the other antennas the loop just couldn't cut it. The mast did its job very well.

Thanks to all of you that I worked. There were many, many great QRP signals out there. 80-mtrs was particularly strong early in the evening but not much activity. 20-mtrs was in great shape. 15 and 10 meters—good signals just not enough of them. 40-mtrs was OK, nothing great this time.

**Rigs:** FT900 and a K1, 5-watts; **Battery Power:** Car battery and a lawn tractor battery.



*Jerry—N9AW*



*Rick—N9KG*

### **Lon—W9XU FYBO Summary:**

Hello to all,

I was going to start with a "pat on the back" for braving out FYBO in a tent in February in Wisconsin. The real hats off goes to all those people who back packed it the high country and sat in snow banks etc. to give this QRP event a go! Man I'm too old for that stuff! Great job done by the lot of you. I set up an old canvas tent out on my wooden deck behind my house. The snow has been on the ground for weeks and has froze and re-

froze many times making it too hard to dig through to pitch the tent in the woods. I had to tie it to the deck with ropes. I was looking at the mess of canvas lying there trying to figure which pole went where...when one of my dogs came along and thought the canvas was there just for him to use as a toilet. A well-placed snowmobile boot and some hot water soon had things back to normal. The tent is up! Well sort of... wind now making tent lift up off deck like a 8x10 foot sail. I added more rope to the railing of the deck. It's looking good now! Threw in an old card table and rug and a few large pieces of firewood for ballast. Took my old Gap Titan vertical antenna out back and tied to my fence with bit of rope. I was ready to face FYBO tomorrow.

The temps over Friday night dipped down into the single digits. At 7:00 the outside temp was around 14 deg F. Looks like a good multiplier temp for me. I open up the tent and looked at the thermometer on the card table. 5 DEGREES! I guess my choice of tent material was good, because it must have held the cold overnight temps inside. I thought the thermometer was bad. After I opened the tent and started getting all the gear inside the temperature came up to the 14 Degrees that my house thermometer was reading. I kept all the batteries and my rig inside the warm house until just before the 8:00 start. I did not know what the cold temps would do to the display on my icom 746. I used two marine batteries, my Icom and paper logging. Getting a computer out there just before the start I thought would be too much work. I didn't trust the laptop in that cold. Got all that stuff out and was ready to go at about 15 minutes after 8:00 locale time. The temperature was at 16 degrees; I was on battery power at 5 watts an output, paper log ready! I started to work em on 20 meters. The wind picked up and kept blowing in the opening that the coax and my power line came through. I used ac power for my lamp and a small heater by my feet. The lamp worked ok...but the heater did just fair trying to keep my feet warm. I had on old snowmobile boots but my feet still were cold most of the day sitting there. The outside air temperature got up to 35 degrees around 3:00pm. At that time the little heater had the temperature inside the tent up to around 50 degrees. Not too bad! That didn't last very long. Most of the time is was near 40 degrees. Every couple of hours I'd go inside for coffee and to warm up some. Guess I worked about 10 hours of the 12 you could. The bands were pretty good. Forty meters being my biggest, with twenty and fifteen right behind. Ten was very disappointing, only had one contact there. I didn't hear very many on eighty either. I CQed the whole time. It has been years sense I used paper logs and keeping a good dupe sheet was just too much in the cold. My

*The QRP Quarterly*

hand is still stiff! I want to thank all those who had to repeat their info to me. It kept snowing off and on all day and the vertical can be noisy at times. I really liked the personal come backs with my name. Don't find that in any other contest! Great bunch of operators in this QRP group! ●●



*Canvas Hilton on Lon's Deck.*



*Lon—W9XU with frozen smile!  
Antenna Set-Up below.*



*Cheeseheads Cranking FYBO Q's*

# How to Host your Own "Pixie Party"

Victor Gann—W4VEG

victorg@mindspring.com

If you are looking for a way to promote Amateur Radio, QRP, CW and get adults WITH youth involved, this may be the way. On January 13, 2001, Venture Crew 73 of the Boy Scouts of America Northeast Georgia Council hosted a radio-building event. We had youth from ages 9 to 16 with adults assisting in constructing a QRP kit for 80 meters. This one-day event had taken a lot of planning to focus the experience, but it was worth it! Here's how to do it with your group. This article, the files and PowerPoint shows linked to the GARS website will make it easy.

## Why and What

Why do this? Our club GARS, hosts a Scout Venture Crew based on Amateur Radio, and we wanted a way to encourage the licensed crew members to upgrade to HF privileges as well as broaden their skills with electronics. The idea to build a kit came up. But which kit? Cost is certainly a factor as well as ability. After searching the internet and all the QRP sites we could find, the Pixie2 by HSC was selected. It had less than 30 parts when totally assembled, cost around \$12 completed, and could be a "first kit" for just about any level of assembly competency. It is a transceiver, so the appeal of making a working radio that fits in a candy box gave it a good twist to promote. Youth from ages 9 to 20 were invited to build this radio with capable of sending and receiving Morse Code over hundreds of miles powered only by a 9 volt battery. The "Pixie2" is marketed by HSC Electronics [www.halted.com](http://www.halted.com). Kit builders were paired with an adult mentor to guide in construction and answer individual questions. Over 50 participants took part in building 20 radios housed in Altoids Mints boxes.

## Advanced Planning

Reserve your assembly hall months in advance. We reserved our meeting place six months ahead! We limited our kit assemblers to 24. This allowed for 6 tables of 4 to be set up in one room with 2 solder irons per table. Space and proper attention to first time builders was the reason for the number. We found it was just right. Any more would have been too many to properly supervise.

Order kits from HSC early. They are assembled by a Ham who works there, with bulk filled orders only by demand. We



asked for ours in November for our January event. If this catches on, the lead-time may be longer. Don't forget to ask for the extra items needed for your radio. The Pixie2 is designed to fit in many enclosures, and does not come with key, audio, or antenna jacks. We chose mono 3.5mm jacks with a BNC antenna. You will also need a power supply and a crystal. We chose a 9v clip at ten cents and an 80 M QRP xtal at 87 cents. That allowed us to get all the parts from HSC in one order.

The most important part of planning is to get people involved! You will need at least

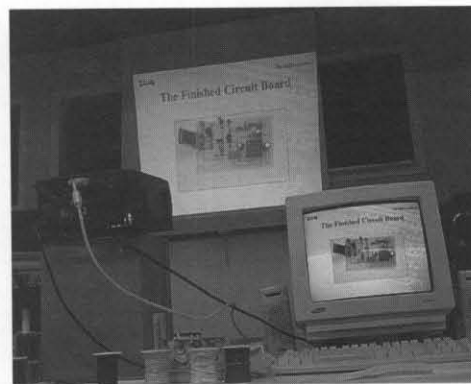





one experienced assembler for every two builders you host. Get people to set up displays, come early to set up, cook the meal(s), be general gophers and so on. We learned there are a few key people you can't do without: 1) Instructor. Get someone who will keep a potentially boring subject hopping all day long. About half of our builders were teenagers and under. Lively is a must. He/she must be able to "translate" technical terms into street language. Remember this is a "bridge event" – that is it gets NON-hams into the hobby. They will need serious help with all the terminology that they see as a barrier. 2) Get a technical crew to troubleshoot the radios. We set up a complete testing lab in another room to completely test each radio. It became a game to see who could put out the most mW of output on their set. One of the lead trouble-shooters had already assembled a Pixie2 to be familiar with the kit. Testing each radio assures the participants of "guided success." (Translation – They will stay interested in radio!) 3) We found a person to run an HF rig was important. Many parents and interested participants had NEVER heard an HF rig in action. Our operator introduced about 20 people to radio on that day! Get a real Ham ambassador to do this. Again, don't scare off public and parents with techno-speak OR as we have found, don't use a \$10,000 radio! People judge whether little Johnny or Susie will get involved by estimating costs on what they see! We used a Kenwood TS 50 and a Yeasu FT 100 because they LOOK

simple and inexpensive. 4) Finally, Get a good Host or Hostess to greet the people and take names! We had a cheery face answer questions, keep records, direct to the restroom, and help in case of burned fingers. This made the event very public friendly.

### Setup

Now you have your army of helpers (we had 30 Hams help!), your kits, your location. Are you ready yet? Not quite. What else do you need? You need tables set up, the overhead projector for the instructor, the computer to run the show on, the assembly notes reproduced for the participants, and oh yes; remember all the things at home in the shack within reach you use on every assembly? You need supplies. Get tools, soldering irons, solder, solder wick, solid wire to connect the jacks, electrical tape, duct tape for the cords (You did get the extension cords didn't you?), cardboard for the assemblers to work on and NOT burn the tables, pencils for those who forgot, your displays and working models; Whew! Can we start now? Remember planning makes the event work. John Q. Public doesn't wait around for you to get started; there are lots of events competing for his time.

The room was set up with two rows of tables running away from the instructor who ran the PowerPoint assembly show. On each side of the assembly room were displays of radio basics and assembled kits. In the rear of the room was the complete working HF station including PSK31.

### Promotion and Sign Up

Advertise and signup all the helpers and assemblers. By the way, the public doesn't know all the Amateur Radio community slang. Introduce it to them AT the event. We used the term "mentors" instead of "Elmers" to advertise the event to the public. We explained what an Elmer was during the event. That is the way we handled ALL the terms new to an outsider to Amateur Radio. Parents will bring their kids to be "mentored"; but to be "Elmered" leaves them feeling unsure. Help them along; explain it in stages.

Keep lists of all who sign up and email them every week before the event. Encourage the adults who provided tools and "come to watch over their tools" at the event. ALL PARTICIPANTS NEED EYE PROTECTION. Stress this before the event and at the event. Let them bring their own safety glasses. Have some extra eye protection on site.

Really play up the event with everyone you know. Get a "wave" of support. Ask for sponsorship for the event. We were able to get five different sponsors during the publicity stage of the event. We got everything from money for kits to door prizes, sponsors for the scout patches to batteries; not to mention all the participants that wanted to see and help at the event.

Oh, and don't be surprised if your adults beg and plead for the "leftover" kits. Get the youth and those outside the HF community signed up for the kits first. Then let the interested adults get theirs!

### Day of the Event

Get there early and set up. Have a crew meet you there at least an hour early. Set up the tables and the overhead first. Then go with the displays and welcome table. Set up your HF rig in a place prominent but out of the way of assembly distractions. Set up your troubleshooting lab. Don't hand out your kits until the time for assembly; you'll lose parts like crazy!

Let everyone arrive and look at the displays and assembled kits. Get started with a relaxed pace.

### Assembly Time

Did you think you'd never get here? Remember, you've assembled your kit two months ago, today is for those new to radio; make today a lot of fun. We followed the PowerPoint show I've made available through the web sites referenced at the end. The show

helps pace the group, and provides a visual reference to the stages of the assembly.

We first discussed radio to explain what we were doing. This is part of the Boy Scout Radio Merit Badge requirements, and it helps smooth into the terms. We covered the basics only; no long winded theory. This is a really good time to introduce a QSL Card. You could hear a pin drop when a card from the Space Shuttle came up. Remember, they've NEVER seen a postcard from another person like this. Professional speakers call this a "grabber". Ham radio is rich with grabbers-use them!

We practiced soldering first, then taught a short course on how to read a schematic. THEN we opened our kits, and sorted the parts on a giant sized pc board blow-up on paper in front of each assembler. BE CAREFUL at this point; some of the color bands can be very close together. One misplaced part can cause your radio to not function.

After the parts are sorted, we worked assembly in stages. PC board first, jacks second, then final assembly. We had adult helpers drill holes in the Altoid tins, so the assemblers wouldn't have to worry about case preparation. When actual assembly gets started, be very flexible to the needs of the group. Don't let the instructor get stuck with one assembler; call an elmer. The instructor's main job is to pace the day. If not, you'll never get done! Some of the assemblers will just take off and be fine alone. Others will need help. Be ready to display the overhead picture they need to see to assist. It REALLY helps to have one if not two finished Pixie2's to show assemblers where things go!

By noon, most of your PC boards will be done or close to done. Break for lunch. Don't let anyone work through lunch. Get them outside to look at objects far away. It will relieve their eyes, and the instructor will appreciate the quiet! We had the participants bring a sack lunch to simplify logistics. It worked well.

After lunch, assemble the enclosure and test the radios. Have an antenna set up inside the hall, and see who is listening. We had someone in the parking lot with a mobile HF rig listening. When all the radios are done, you have time to operate, look at the displays (they will mean more to them now), hand out prizes and get acquainted. We had a simple chili supper with hot dogs around 5:30. We were all shut down and out of our meeting place by 7 PM. Be careful to vacuum up all the snipped leads!

#### Extras and Notes to make it special

**Handouts** – We had lots of handouts to aid in construction. See the Crew web site for the files.

**Displays** – We had 6 display boards explaining radio basics with dozens of handouts.

**Pop Quizzes** – How many watts did the first manned spacecraft radio have? (5) What could you use this HT thing for anyway? Can anyone here show me how to send for help using this flashlight? (SOS) Have some questions ready for slow moments and to keep interest high. It lets people feel they are contributing to this "new" radio thing.

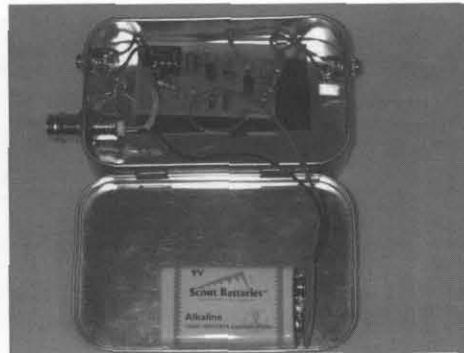

**CW demo** – In the slow part of the day, we ran the Code Quick Escargot II game, the CW version of Wheel of Fortune. It was a big hit. Participants who knew code played the game off and on all day. I can heartily recommend Code Quick to teach youth. They love the "language" idea. My wife KG4ETR went from nothing to perfect 5 WPM copy on her test in less than a month and still getting faster... Forget all the arguments about the "best" way to learn code. Just learn it! This is a great introduction.

**Radio and Electronics Merit Badge** – We had nine scouts out of the twenty assemblers eligible for merit badges. Covering the basics of the badge requirements over the course of the day was a draw for the scouts.

**Assembled QRP Kits** – We had over 20 assembled kits for the assemblers and Elmers to see and look forward to.

**Inter-Club participation** – We had members of GARS, NOGA QRP, and QRP ARCI president, Jim Stafford W4QO helping in our event.

**Key Assembly** – NOGA QRP furnished a simple key kit for the assemblers. It was simple and a great addition to the final assembly.

**Additional Media Shows** – We had slide shows and videos promoting Scouting, QRP and Radio running at breaks, lunch, and operating time. With the displays, the atmosphere was not unlike a trade show.

**Prizes** – We gave prizes for the most mW, the first done, the best Elmer. Reward somehow about 25% of your group publicly; it promotes future participation like nothing else.

**Pictures, Pictures, Pictures** – You would think this was someone's first grandchild! There were over 300 pictures taken of this event! The best of the best are on the Venture Crew site explaining the event. Keep your event special; take pictures and get them in as many papers and magazines as possible! People love to be seen in the news.

#### Credits and Sponsors

The event was sponsored by Gwinnett Amateur Radio Society [www.gars.org](http://www.gars.org), QRP ARCI [www.qrparci.org](http://www.qrparci.org), the international low power experts organization, NOGA QRP the North Georgia low power communication club [www.qsl.net/nogaqrp](http://www.qsl.net/nogaqrp), Kenwood USA Amateur Radio, Trooper Batteries [www.trooper-batteries.com](http://www.trooper-batteries.com) and Venture Crew 73 (Follow the link to Crew 73 on the GARS homepage). Additional information may be obtained from Victor Gann at [victorg@mind-spring.com](mailto:victorg@mind-spring.com). ●●



# QRP Contests

Randy Foltz—K7TQ

rfoltz@turbonet.com

This version of Contests contains full coverage of the Fall QSO Party, the Running of the Bulls, and the Holiday Spirits Homebrew. As in other issues the results here are sorted by state. If you would rather see them sorted by descending score, take a look at the QRP ARCI Contest web page at <http://personal.palouse.net/rfoltz/arci/arcitst.htm>. This issue also contains full rules for the Hootowl Sprint, Milliwatt Field Day, and the Summer Homebrew Sprint.

Brian Cieslak, AE9K, is now printing and sending contest certificates. Welcome aboard Brian.

A thank you to W2MY, Steve, for his long service in printing and sending contest certificates. A lot of us got our first look at a certificate because of your hard work. See you in a contest, Steve.

Finally, after each contest use the High Claimed Scores form at <http://personal.palouse.net/rfoltz/arci/form.htm> to send me your contest summary. Watch the scores change nightly at 9 PM Pacific Time for 10 days after the contest by taking a look at <http://personal.palouse.net/rfoltz/arci/highclm.htm>. If you use the High Claimed Scores form, you still need to send me a copy of your log.

## FALL QSO PARTY 2000

The Fall QSO Party, held October 21 and 22, was one of ARCI's premier contests. Contesters found band conditions in good shape with solar flux of 160, and an A-index of only 5. Single band interest was up with 6 folks doing 10 m only, 4 on 15 m only, 5 on 20 m only, and 9 on 40 m only. DX turnout was encouraging with entries from France, Scotland, Bulgaria, Lithuania, England, Japan, the Netherlands, Panama, and Belgium.

The top five finishers didn't look much different than last year. As always, Bob, N4BP, lead the pack. New comer to ARCI contests, Larry, WJ1R, finished second. Both Al, K0FRP, and Jim, N0UR, were near the top once again. Notably absent was Ron, KU7Y, who was off full-time RVing in the west.

Once again the Aluminum Kings ran away with the team competition posting a score of 11,541,000. With the 1<sup>st</sup>, 2<sup>nd</sup>, 3<sup>rd</sup>, 4<sup>th</sup>, and 6<sup>th</sup> place finishers it would be nearly impossible to beat them! Just to keep them a bit humble, they were well off their record breaking score from last year of 13,218,194.

[www.qrparci.org/](http://www.qrparci.org/)

The Utah Ion Busters put in an impressive score with only three members. Put together a team for the 2001 event and give the Aluminum Kings some competition.

Participation was down a bit compared to last year. The Pacifcon Hamfest presented a very large competition for QRPers. For the 2001 Fall QSO Party there will be no conflict with Pacifcon! The date for the 2001 Fall QSO Party is September 29 thru the 30th.

One final note: There were more entries than usual that did not include log sheets. If you sent me only a summary sheet without logs, you were considered a check log. To be included as an official entry you've got to send me a copy of your log. Either e-mail or regular mail is fine.

### TOP TEN

N4BP	2,607,770
K7RE	1,978,280
WJ1R	2,328,480
WA7LNU	1,721,517
K0FRP	2,315,170
WJ9B	1,207,500
N0UR	2,311,300
N2CQ	1,076,040
VE5ZX	2,101,050
W3BBO	1,072,974

### BAND WINNERS

40 m	K9PX	286,748
20 m	K7NTW	193,050
15 m	KF7MD	111,342
10 m	WX7R	132,468
High-band	WD5ICQ	211,869
Low-band	N4ROA	320,796

### TEAMS

#### Aluminum Kings

K7RE, K0FRP, N4BP, N0UR, WJ1R  
11,541,000

#### Utah Ion Busters

KO7X, WA7NLN, NC7X  
2,904,531

#### NJQRPeaNuts

W2AGN, K2HPV, N2CX, W3BBO, N2CQ  
2,678,970

#### 2000 Fall QSO Party Soapbox

W1VT—Worked 18 countries. KB1CKS—Thanks for the opportunity to work in a great contest. KA1DDB—Great contest—enjoyed every minute! K7RE's "QRP Dupe" logger was a big help. AA7EQ—First contest. Had a great

*The QRP Quarterly*

time. N5UW—Storms on and off all weekend. Lots of rain static on antennas. Had lots of fun, but wish more folks had 15 m rigs! Tornado warnings in the last 30 minutes. Had to QRT! WA2OCG—Worked G, KD, and JA for DX multipliers! K5QLF—Another contest. N4JIU—Big thrill when HP1AC called me—I felt like a rare DX station in a pile-up! N3IUT—Another fun contest. A great bunch of ops! K0ZK—My big thrill was working OH9VL who was running only 400 milliwatts. AF4PP—Great contest!! The fun quotient is through the roof. K2HPV—My "new" Argonaut 509 held its own in the fray. What a receiver! A 75 year old op with a 28 year old rig! Awesome! KG9PQ—A very fun contest. Made my first DX QRP contact (England) from my car. W4MVZ—Wish I had time to operate the full 24 hours allowed: solo opr here. Had fun! W2BVH—27 different states. 6 different countries in 7 hrs op time. Yikes! W3BBO—Great band conditions! Thanks everyone for a great time. VE3KQN—I operated 500 mW maximum during the contest. KF3CV—Not serious contester—filing to make sure contacts get credit. KD7BOD—My first QRP-ARCI contest (just joined, been ham 2 yrs)—QRP bug bit me and no cure in sight! NK6A—Working Japan and Panama plus Great Britain with 5 W was awesome! KB0JUL—My best score yet! Had a blast! Glad to see all of the participation. AE4EC—Operated as much as time between honey-do's would allow—conditions were reasonably good. KE4VPN—First CW contest. Had fun, but did awful. HI. Will do better next year. N7OU—Bad line noise here spoiled some of the fun. AC7GM—Great contest! Really enjoyed the time I was on the air. N4UY—Another fun ARCI contest—new QRPp states with the Tuna Tin and a couple new 2-way QRP countries on 10 m. Thanks! K2ZR—First entry and I had a great time! AE4IC—It was great fun to work 25 DX stations 2X QRP! K7NTW—All operators very patient and picked up 2 needed states. N4ROA—Really enjoyed listening to all the good music (CW). Hee hee. AK3X—Operations from parked car. Had a great time. W3TS—Weather was too nice to stay inside and contest, so only managed 1.5 hours on Sunday. N0WM—I have just renewed my membership dues for another year. W2JEK—First contest with OHR500. KW3U—Had great fun with little QRP20. Worked lots of guys from QRP-L and even N1FN from Morse Xpress. K2JT—Limited time available. Good activity especially on 10 m. VE7SL—Just finished the new 20 m Tuna Tin in time for the contest. Conditions not great, but great fun. All QSOs were on CQs! 17 states/3 provinces. W2QYA—Power output measured with Radio Shack Power/SWR Meter calibrated by me with a Heathkit VTVM measuring RMS into 50 ohm non-in-

April 01 57

2000 Fall QSO Party

QTH	Call	Score	Pts	SPC	Power	Bands	Time	Rig	Antenna
AK	AL7FS	117,096	328	51	LT5	20,15,10	8	TS450S	KT34A @ 40'
AL	W4DEC	924,840	1101	120	LT5	80,40,20,15,10	17.5		
AZ	K7RE	1,978,280	1444	137	LT1	40,20,15,10	24	K2	3 el trap yagi @ 35'
	NQ7X	931,740	879	106	LT1	40,20,15,10	14	TS850S	Triband + 40 extenders
	AA7EQ	62,678	242	37	LT5	40,20,15,10	16		
BC	VE7SL	41,630	181	23	LT1	40,20	6	HB Tuna Tins	Yagi & half sloper
CA	NK6A	161,504	412	56	LT5	40,20,15,10	5	K2	C4
	N6GA	127,596	372	49	LT5	20,15,10	4.5	K1 & K2	Yagi @ 35'
	KN6YD	45,360	240	27	LT5	10	9	FT890	Rotary dipole & R7
CO	WJ1R	2,328,480	2016	165	LT5	160,80,40,20,15,10	23.75	FT1000D	C4 & Beverages
	K0FRP	2,315,170	1619	143	LT1	160,80,40,20,15,10	21		
	N0IBT	114,954	322	51	LT5	40,20,15,10	8.5	TS870	Dipole
	KF7MD	111,342	482	33	LT5	15	7.5	TS680	Vee beam & 3 el yagi @ 55'
	N0RC	94,400	236	40	LT1	40,20,15,10	6	NC40A, K2	Attic dipole
	KI0II	93,107	283	47	LT5	80,40,20,15,10	5		
	AB0GO	66,612	244	39	LT5	40,20,15	5	IC706	MiniG5RV
	W9KV	27,972	148	27	LT5	20,15	4	NC20, TS440	136' dipole
	W0LQ	25,515	135	27	LT5	20,15,10	7	TS570S	3 el yagi @ 30'
CT	W1VT	65,856	294	32	LT5	10	6	K2	Force 12 C3S
	N1EI	57,505	265	31	LT5	80,40,20,15	6	OHR 500	80 m doublet @ 50'
Eng.	G3XJS	170,100	405	60	LT5	20,15,10	8	K2	Western DX32 2 ele
FL	N4BP	2,607,770	1727	151	LT1	160,80,40,20,15,10	24	FT1000MP	TH7DX @ 64', 402BA @ 50'
	W4MVZ	674,128	926	104	LT5	40,20,15,10	15	IC738	GAP Titan
	K4KJP	77,490	270	41	LT5	40,20,15,10	6	Sierra	40 m dipole & 20 m dipole
	W4STX	14,112	96	21	LT5	20,15,10	3	TS140S	10 m Hamstick, G5RV
France	F8AKC	57,750	275	30	LT5	10	20	Paragon II	Cushcraft AR-10
GA	AF4PP	137,592	378	52	LT5	40,20,15,10	12	Sierra	80 m dipole @ 50'
	K4GT	30,030	195	22	LT5	20	8	TS890	C3S @ 40'
IA	KB0JUL	121,765	355	49	LT5	40,20,15	8	Argonaut 509	Dipoles
	KQ0I	104,265	331	45	LT5	80,40,20,15,10	7.25	TT 580 Delta	Mult band dipole @ 20'
IL	KG9PQ	66,822	258	37	LT5	40,20,15,10	8	TS570S	Hamstick monobander
	N9MZP	27,489	187	21	LT5	40	13	TS450	G5RV @ 50'
	N9EXY	3,570	51	10	LT5	40	12.5	IC751	Dipole @ 15'
IN	N9SE	354,960	522	68	LT1	40,20,15,10	6	K2	Trap dipole @ 25'
	K9PX	286,748	931	44	LT5	40	16	K2	80 m loop
	W9DZ	167,811	393	61	LT5	80,40,20,15,10	9	IC756	R7, Half sloper
Japan	JR0BAQ	196	14	2	LT5	15	1.5	TS440V	DJ2UT beam @ 50'
KY	KG4BIG	181,720	440	59	LT5	40,20,15,10	3.5	Omni VI+	135' CF, 2 L yagi, dipole
Lith.	LY2FE	195,363	443	63	LT5	20,15,10	10.25	K2	Yagis, 200 m long wire
MA	K1GDH	101,661	309	47	LT5	80,40,20,15,10	10.5	TS690S	TA33 jr
MD	W3PO	91,200	240	38	LT1	20,15	12	FT200	
	AK3X	76,076	286	38	LT5	40,20	4.5	DSW40 & DSW20	Hustler mobile whip
	KF3CV	3,213	51	9	LT5	20	3	TS520	Dipole @ 40'
ME	K0ZK	578,900	827	100	LT5	40,20,15,10	19	K2	Attic 20 m dipole
	KB1CKS	20,020	143	20	LT5	40,20,15	5	Scout	Tuned Random
MI	KA1DDB	545,776	886	88	LT5	80,40,20,15,10	17	Sierra	G5RV @ 35'
	K8CV	151,011	423	51	LT5	40,20,15			
	W8RU	127,596	372	49	LT5	40,20,15,10	3	FT1000	C4, C3
	AB8DF	61,495	251	35	LT5	80,40,15,10	4	Triton IV	105' dipole @ 40'
MN	N0UR	2,311,300	1594	145	LT1	160,80,40,20,15,10	23	FT920	3 el yagi, wires
	W0UFO	436,135	733	85	LT5	80,40,20,15,10	10.75	FT840	Zepp & triband
MO	KR0I	382,200	700	78	LT5	40,20,15,10	11.5	OHR400 & IC746	HF5B & R7000
	N0WM	29,484	162	26	LT5	80,40,20,15,10	10	Century 21	15 m Yagi & dipoles
MT	AC7GM	15,428	116	19	LT5	40,20,15	5.5	Alinco DX77T	G5RV
NC	WJ9B	1,207,500	1380	125	LT5	160,80,40,20,15,10	21	TS950SDX & K2	A3, 2 el 40, 80m delta, shunt fed tower 160'
	WA4DOU	1,070,160	1176	130	LT5	80,40,20,15,10	22	FT840	C3SS @ 40' & Inv vee @ 40'
	AE4IC	935,046	1086	123	LT5	160,80,40,20,15,10	18	K2	3 el beam, horiz loop
	AE4EC	108,045	315	49	LT5	80,40,20,15,10	8.5	SW40+, MFJ9020, TT	Argosy, HB H-Loop, Car. Windom, Yagi
	KE4VPN	4,935	47	15	LT5	80,40,20	15	K2	Carolina windom
Neth.	PA9RZ	1,302	31	6	LT5	15,10	5	Argo II	Ground plane
NH	KN1H	134,100	298	45	LT1	160,80,40,20,15,10	4	QRP+	Dipoles
	W1PID	3,087	49	9	LT5	40,20,15	0.5	FT900	Off center fed dipole
NJ	N2CQ	1,076,040	1281	120	LT5	80,40,20,15,10	16	TS850sat	CF Zepp, TA33jr
	W2AGN	429,968	698	88	LT5	80,40,20,15,10	12	K2	KT34A, GAP vert, dipole, zepp
	K2JT	163,590	410	57	LT5	80,40,20,15,10	4	TS130V, TS50	Inv vee & doublet
	W2BVH	112,378	349	46	LT5	40,20,15,10	7.25	K2	80 m & 10 m CF Zepp
	K2HPV	77,308	251	44	LT5	40,20,15,10	4.5	Argonaut 509	GAP Titan
	W2JEK	73,640	263	40	LT5	80,40,20,15	5	OHR-500	Dipole, gnd plane, end fed hertz
	N2CX	22,680	162	20	LT5	80,40,20	2.5	Sierra	Squirt & MP-1
NY	WZ2T	798,945	1087	105	LT5	80,40,20,15,10	16	TS940S, FT847	80/40 trap dipole @ 30', 40 m dipole @ 50'
	K2QO	740,145	1007	105	LT5	80,40,20,15,10	21	Omni 6+	40 m loop, HF2V, dipole, 3 el beam
	K2ZR	347,760	690	72	LT5	160,80,40,20,15,10	8	HW9	InvVee, CF wire, Delta Loop

	W2QYA	7,590	69	11	LT1	40,20	3.5	HW8	Inv Vee
OH	AB8FJ	35,343	187	27	LT5	20,15,10	5	Argo II	Random wire
OK	K5AAR	337,365	595	81	LT5	80,40,20,15,10	16	HB Xcvt	Dipole
	N5UW	91,840	410	32	LT5	15	8.5	OHR100	Tribander @ 50' & vert
	K5DP	68,680	202	34	LT1	40,20,15,10	3	HW-9	40 m horiz loop
ON	VE3KQN	162,110	377	43	LT1	20,15,10			
OR	N7OU	431,634	717	86	LT5	40,20,15,10	6	K2	Wire beams
	WX7R	132,468	498	38	LT5	10	11	FT920	Lazy H, Yagi
	K7EL	43,617	201	31	LT5	40,20,15,10	6		
PA	W3BBO	1,072,974	1299	118	LT5	80,40,20,15,10	20	K2	Horiz Loop & vert
	K3HX	134,421	519	37	LT5	40	13	TS870	Dipoles
	N3IUT	103,362	321	46	LT5	40,20,15,10	11	QRP+	Force 12 C4
	W3TS	40,800	136	20	LT250	160,80,40	1.5	HB	1/8 wavelength T on 160, inv vees 40 & 80
	KW3U	13,335	127	15	LT5	20	5	OHR 20 m	R7
	N3CZB	1,260	30	6	LT5	10	2		
Panama	HP1AC	324,310	565	82	LT5	40,20,15,10	15	TS430S	TA33jr
RI	K8ZFJ	52,290	249	30	LT5	40,20"	8	IC706	G5RV
SC	W2UX	27,118	149	26	LT5	40	3	Red Hot 40	G5RV
Scotland	GM4XQJ	56,203	259	31	LT5	10			
SK	VE5ZX	2,101,050	2070	145	LT5	80,40,20,15,10	22	IC736	2 el quad, sloper, vertical
TX	K5NZ	583,590	794	105	LT5	40,20,15,10	4.3	OHR400, FT1000MP	KT34XA @ 96', KT34A @ 61', TH6 @ 31'
	W5TB	268,450	590	65	LT5	40,20,15,10	15	K2	G5RV & TA33
	WD5ICQ	211,869	531	57	LT5	20,15,10	21.5	Omni C	500' long wire @ 50'
	K5HDX	103,040	322	32	LT1	20,15	18	HW8	Gnd plane, dipole
	K5ZTY	66,640	238	40	LT5	40,20,15,10		K2 C4S	
	W5WO	35,750	143	25	LT1	20,15	5	Home built	Dipoles
	N4JIU	9,450	90	15	LT5	40	8	MFJ-9040	End fed wire
	WA3GYW	4,956	59	12	LT5	40,20,15	1.25	HW8	120' long wire
	K5QLF	2	2	1	GT5	15	0.03	K2	Zepp
UT	WA7LNW	1,721,517	1673	147	LT5	80,40,20,15,10	20.5	K2	2 el wire delta loops
	NC7X	882,574	1042	121	LT5	80,40,20,15,10	14		
	KO7X	300,440	580	74	LT5	80,40,20,15,10	5	FT1000	Yagis
	KD7BOD	179,487	407	63	LT5	80,40,20,15,10	22	IC756	R6000 & 40 m dipole
VA	WR4I	334,194	654	73	LT5	80,40,20,15	9	K2, Argo 515	Carolina Window
	N4ROA	320,796	804	57	LT5	80,40"	16	K2	450' loop & inv L
	K4TX	95,697	441	31	LT5	40	6.11	FT1000MF	40 m 2 el delta loop
	N4UY	78,736	304	37	LT5	40,20,15,10	15	Tuna Tin & FT840	Dipoles
	N4EUK	3,388	44	11	LT5	15,10	2	K2	100' long wire
WA	K7NTW	193,050	495	39	LT1	20	19	NN1G	2 el quad
	N0AX	142,044	356	57	LT5	80,40,20,15,10	4		
	W7JR1NKN	56,595	245	33	LT5	15,10"	5.5	TS680V	Delta loop
WV	N8BL	18,032	161	16	LT5	40	6	MFJ9040	Attic dipole

(Check logs: WA1GWH, K2UD, WA2OCG, N3AO, KD3FG, K4AGT, W4FMS, N7RVD, W7GT, LZ2RS, ON5EX)

ductive load. N8BL—My first QRP ARCI contest. Could only operate 6 hours. Seems points reflect ability to get and hold a calling frequency. K2UD—Conditions good, but not so much activity. Come on in guys, the water is fine! F8AKC—Very nice for my first contest QRP. I will look for future contests. W5TB—Excellent conditions. Thanks all! K4KJP—Battery power all the way with new Sierra. Good turnout and lots of fun! WA4DOU—Lots of fun. Good conditions on higher bands. My best QSO Party score yet! KF7MD—Had a great time. Lots of new members. (Still can't come close to my 1990 15 m score of 312k). PA9RZ—When I realized what was going on (next to JOTA and German contest) I decided to make a few more QSOs in a real contest (no 599 disease...!) K3HX—Great fun! No phone QRM this time. Got second dipole up and trimmed just in time. ON5EX—Great party on 10m. Weakest sigs seem to have biggest ears? >5W should not be allowed in this kind of contest. WJ1R—First time for this contest. N3AO—Had a great time. N9SE—My first ARCI QSO party. I thought there wouldn't be much action, but this contest ROCKS! Great warmup for Sweepstakes. K4TX—Great to hear everyone! Stayed on 40 mtrs. Did not hear any activity on the other bands. K9PX like a "beacon" here in Virginia. K2QO—First real contest

with my "new" Tentec Omni 6+. Wow, what a rig! It was great moving ops to other bands for additional mults. KD3FG—I operated on and off through the weekend. One of these years I'll combine this event with a camping trip to get away from the RFI in the house. W2UX—Wish I had more time to play! NQ7X—Due to care giver duties, could op only in short periods. Ran 950 mWatts and was surprised to have Europeans and JA answering my CQ. N2CX—Had to fit contesting in around chores. Shakedown for MP-1 proved very successful. JR0BAQ—It was my enjoyable time just as in past QSO Parties. I made a mistake that during most of contest time the attenuator was ON. See you all QRPers in next party! G3XJS—Conditions were particularly good on 10m during (my) Saturday evening, with openings into the West, and mid West. My best ARCI Contest entry yet. Thanks for the FUN. N9MZP—Could only operate a limited number of hours. Stayed only on 40 meters and was running 1 watt. N0RC—Thanks all who dug out my <1W sig, I appreciate you efforts. The ARCI QSO parties are one of my favorite events. K8ZFJ—Where did all the RTTY QRM come from on 40M? N2CQ—Great activity but my antenna stuck toward Japan and no JAs worked. (Preliminary excuse for score). K7RE—Local severe thunderstorms caused high QRN on 40 and

even 20 meters. New 40M MOXON beam came down very early AM Sunday. KR0I—Missed the early 10 meter opening to Europe but did manage to work GM4XQJ and HP1AC Sunday afternoon. Also caught AL7OK and AL7FS on 15 just before the end. K5NZ—Had great time moving the good ops to other bands! Just for the record, QSY 15? means would you be good enough to try a QSO with me on 15m.. HI HI. W0UFO—Got a late start and slow at times but was on and off for a great time. W2AGN—Started to work only 4 hours but got carried away. First time I used computer logging drove me nuts! WR4I—Started this on the outside on our deck since weather was so nice but had to move indoors after swarms of lady bugs kept getting into my face, nose, ears, etc! WA1GWH—I like to try strange antennas. Operated entire contest with 90 ft center fed insulated wire laid out on the lawn east-west. It was fed with 300 ohm twin from a Johnson Matchbox. WX7R—10 Meters much better in OR this time! Not quite up to last cycle's "QRP Heaven" but it is gettin' closer. Now when we gonna do this on 6 meters? WA7LNW—Band conditions were mixture of normal to below normal here in southwestern Utah, near Zion National Park. NC7X—The ARCI SPRING/FALL QRP contests are among my favorites. Great show for some poor condi-

tions out West. Had to dig thru the ion fog for many Q's during daylight. N4EUK—Lots of fun for operating a short time. N6GA—Started on 10 meters Saturday morning, got as many Europeans as USA stations! Used the K1 on 15 and 20, and the K2 on 10. Mojo was really flowing! VE5ZX—It was fun. It seems to me that those of us that only have to send a single digit power level have a speed advantage over those who have to send a 4-5 digit membership number. W8RU—Thanks to all for the QSOs. W9KV—Had a great time, but would sure like to see more participants. WA4DEC—It was a good contest and stations spread out a little more this year. Activity did not seem too high, perhaps due to Pacificon. W7/JR1NKN—Thank you for the QSOs. WZ2T—My first time running a full SO2R. I think had I not missed all day Saturday helping a friend with a tower, I would have broken 1 million points and 300 Q's. AB0GO—Lots of fun, as usual, but didn't find as many signals as last year. K5ZTY—Sorry that I didn't put in a better effort guys. My weekends seem to be too busy lately. I had fun what few Qs I made though. Thanks ARCI for putting it on. KI0II—Good conditions about anytime I got on. KQ0I—20 and 40 were miserable here, but 15 was better than usual, so it kind of evened out. Really some good operators, it was fun. K0FRP—Conditions were not the best but 10m had a good opening to Europe. 40m was not well populated or stations stayed on 20m late into the evening. N0AX—It was a lot of fun moving multipliers between 20, 15, and 10. I encourage all participants to check out the North American QSO Parties in January and August! KO7X—Nice DX opening Saturday evening. W0LQ—Really hadn't geared up for a test, but sure enjoyed the little I did. K5HDX—I heard a 100 mW station in there, but never got his call. QRP ops have good ears! WA3GYW—I worked more stations than I thought that I would. Propagation was very good.

### HOLIDAY SPIRITS SPRINT 2000

The Holiday Spirits Sprint was held December 3, 2000 with a solar flux of 155, and an A-index of 10. Most contestants reported good conditions, especially on 40 m. With the good conditions more folks are using the QRP power levels with results that often surprise them.

For those of you who like to compare to last year's event, the number of participants was up from 54 to 57 (not much of a change) while all of the top three scores were below

#### TOP THREE

K5ZTY 399,260

K0FRP 294,294

N0UR 249,908

#### BAND WINNERS

10	N3CZB	560
15	WA0OTV	1,665
20	K9OSC	48,825
40	K9PX	90,470
High Bands	N4BP	226,489

last year by about 15%. Last year's solar flux was 145 and an A-index of 15. One would think scores should have been higher. Like sports the stats—these don't tell all the story.

Next year's event will be Dec. 2, 2001.

### 2000 Holiday Spirits Homebrew Sprint

W3DP—Good conditions on 40. Light activity first 2 hours. FB ops. AA2YO—All operation with homebrew transmitter and homebrew receiver on 40 meters with 200 mW of power. N5UW—Lots of noise on 20 m today, but worked some new folks for the first time. Had fun! K9OSC—Had fun time. Good operators and fine competition. 4 hours is just right. AF4PP—Another great ARCI contest! Enjoyed cranking back the drive to under 1 W. Maybe next time try < 250 mW. K4AGT—Got 2 new states. Only 1 to go! W4MVZ—This contest is at a bad time. Would be better Saturday 11 AM to 3 PM. Contest on Sunday is difficult due to Sunday dinner. WJ4P—Lots of fun! Thanks! N1EI—Activity seemed down from past years. VE7BLU—Age 78. Without QRP types ham radio would be finished. Ham since the 30's. WD4IFN—Almost missed it! First QRP ARCI test. W3TS—Ran the 160 m ARRL QRP and lost a lot of sleep, but still had a little contest "drive" for the sprint—then the relatives came to visit and I had to QRT. K9OSC—Had a great time. Good operators and fine competition. Four hours is just right. W4NJK—Great homebrew test. Heard fair amount stations on 20 in CA but poor conditions. Still managed 7 SPC's best, BC, ND, and FL. K1 was a real performer and much fun! WB3AAL—Wow, 40 meters was very good. I had several people come back to my CQ at the same time. K0FRP—I had some weak ones I could not pull out. But for the most part a good Sprint after working the 160 m contest. Double 294, now that's [a] tough [score] to do. N7RVD—Super conditions! After many years of 10-15 qso per hour contest rates, it was a real blast to work two 35 QSO hours. A VERY BIG THANK YOU to everyone that pulled me out. W2AGN—Gave the new K1 a workout on 40 and 20. Worked great. Sierra served on 10M with the DL-QRP amp, and used the K2 on 80 and 15. Great conditions, lots of fun, as always. N0UR—Maybe I will keep this ol' HW-9. Nice little contest. W2QU—Tough to operate and babysit at the same time! My 18 month old daughter always wants to play with the paddles! Lots of fun nonetheless. N0RC—A non-contest station, called to ask what was going on. I took a few minutes to explain, then told him my power was only 900mW, his response was "WOW!" KD3FG—What fun -- I love these sprints! It always amazes me where I can contact with 5W and a simple 20m wire dipole in my attic. WA4CHQ—Normally run 900mw, but decided to try my Dixie Pixie (450mW) and was really amazed! I forgot that I was operating out of a mint tin! AA7EQ—

### Running of the Bulls 2000

This was a QRP ARCI sponsored piggy-back contest on ARRL CW Sweepstakes that took place November 4 and 5, 2000. The idea was to encourage more participation in the QRP category. Operators could volunteer to be a "Bull" or a "Matador". A Bull agreed to operate a minimum of 15 hours during the

contest and call CQ as much as possible. Being a Matador was less stressful without the longer operating time and CQ requirement. The goal was to have a Bull in each of the 80 sections. We got a bit over half with 42 sections with Bulls. The piggy-back scoring was the number of Q stations contacted during the CW SS if you were a Bull or the number of Bulls contacted if you were a Matador.

As expected being a Bull wasn't easy. Holding a frequency with a mighty 5 watts was uncommon. However, many Bulls suggested running the event again next year, so we will. Mark your calendar for November 3, 4, and 5, 2001 for another Running of the Bulls.

QRP ARCI President Jim Stafford—W4QO, who along with Ed Hare—W1RFI dreamed up this event, promised a plaque and an ARRL Handbook for the top Bull and for the top Matador. The top Bull was K5NZ from STX with 132 Q stations. The top Matador was KO4PY from NC with 24 Bulls worked. At press time in early-February Joe

#### BULLS

Place	CallSec	Qs	
1	K5NZ	STX	132
2	K0FRP	CO	127
3	K7RI	WWA	100
	(N0AX op)		
4	N4ROA	VA	91
5	N0UR	MN	85
6	N7IR	AZ	83
7	K9AY	GA	74
8	K7LOW	OR	62
9	WZ2T	NNY	58
10	AF5Z	STX	56
11	WB3AAL	EPA	54
12	K9IUA	ND	53
13	W2EB	WNY	52
14	N9SE	IN	45
15	W4FMS	SFL	44
16	K6MI	SJV	36
17	KX7L	WWA	36
18	K4FB	WCF	34
19	AA0ZZ	MN	33
20	N7RVD	WWA	32
21	W4QO	GA	27
22	W4IM	VA	25
23	K7RE	AZ	22
24	W9FHA	IN	21
25	W2XS	NLI	13
26	KA9NZI	IL	12
27	W6RCL	LAX	10
28	AE4EC	NC	8
29	W4DU	GA	7
30	AG4CZ	KY	6
31	N6WG	EB	2
32	KH6B	PAC	2

#### MATADORS

Place	Call	Section	Bulls
1	KO4PY	NC	24
2	KB0R	MN	16
3	WD3P	MDC	13
4	N2CQ	SNJ	8

Spencer— KK5NA, was preparing the plaques.

### 2000 RUNNING OF THE BULLS

AE4EC—Tried calling CQ several times on the hour but had only two stns come back to my CQ and they were not Q stations. AF4PP—Rig was a Sierra at 1 to 2 watts, battery power, and either an 80M dipole or 40M inverted Vee. Conditions were great especially on 15M. AG4CZ—Mast would not lock upright so I had to switch to a backup vertical and couldn't hear a thing. Managed to squeeze in 109 QSO's over the week-

end on a short vertical stuck in the backyard. KOCO—Played just enough to spend 5 bucks and get my pin, but found bulls K5NZ and K0FRP plus several more Q stations. Good conditions. K0FRP—Q's 760 in 76 sections. 127 Q stations worked. K5NZ—Great QRP activity! Many Matadors put a dart in this Bulls back! Thanks for all the QSO's! K6MI—The only band I could call CQ on was 10 meters, and even then the highest rate was 38/hr in the first hour. Being a Bull for the first time encouraged me to try and call CQ. K7LOW (K7FD op)—Lots of fun! The K2 worked fantastic! Thanks to all who

worked our club station. K7RE—Many more Q stations this year, hopefully more next year. I'll be looking for them! K9AY—What a great idea to stimulate QRP activity! Good conditions and high awareness of the fun/challenge of operating QRP in a major contest seemed like a great combination. K9IUA—This was a blast, let's do it again next year. I called CQ for probably 15 of my 16 hours on the air, just waiting to see what my trolling would bring in. KA9NZI—Despite rather disappointing results I think this was an excellent idea, and I hope it will be continued next year. This bull was made into ham-

### 2000 HOLIDAY SPIRITS SPRINT

QTH	Call	Score	Pts	SPC	Power	Bands	Time	Rig	Antenna
AL	K4AGT	18,566	114	17	LT5	20	1.5	OHR100	Dipole
AZ	AA7EQ	20,192	91	16	LT5	40,20,15,10	4	K2	GAP Titan
BC	VE7BLU	17,450	35	7	LT1	20,15,10	2.75	K2	134' CF Zepp
CA	W6ZH	203,910	341	51	LT1	160,80,40,20,15,10	4	K2	Yagis, vert
	W6SU	39,000	60	15	LT1	160,80,40,20,15,10	1	K2	R7, 3 ele beam
	W4NJK	16,715	35	7	LT5			K1	20 m dipole @ 15'
CO	K0FRP	294,294	539	78	LT5	40,20,15,10	4	TS850	Yagis
	N0RC	116,800	220	44	LT1		3.5	K2	Attic dipole
CT	N1EI	46,265	103	17	LT250	80,40,20,15	4	OHR500	80 m doublet @ 50'
FL	N4BP	226,489	507	61	LT5	20,15	3	K1	TH7DXX @ 65'
	W4MVZ	142,100	350	58	LT5	80,40,20,15,10	3.5	IC738	GAP Titan @ 5 m
GA	K4BAI	156,016	398	56	LT5	40,20,15,10	4	FT1000MP	TH6DXX, dipole
	AF4PP	50,280	147	24	LT1	40,20,15	4	Sierra	80 m dipole
	K4GT	16,050	85	13	LT1	20	3	Sierra	C3
HP	HP1AC	41,250	150	25	LT5	20,15,10	4	HW9	TA 33jr
IA	W0PWE	83,660	207	38	LT1	40,20,15,10	3	HB, Argo 505	Trap and open sleeve dipole
	KQ0I	22,792	148	22	LT5	20,15	1.75	TT 580 Delta	Multiband dipole
ID	K7TQ	5,735	35	3	LT5	40	0.5	K2	GAP Titan
IL	KG9PQ	9,744	87	16	LT5	20,15,10	2	TS470	Hamsticks
IN	K9PX	90,470	370	33	LT5	40	4	K2	80 m loop
KT	K4AVX	17,462	82	13	LT5	40,20,15	2	MFJ Cub, DSW-40, Argosy	80 m dipole
MD	KB3WK	109,320	272	31	LT1	80,40,20,15,10	4	K2	
	KD3FG	50,968	158	28	LT5	40,20,15,10	3	K2	20 m attic dipole
	N3FZX	5,840	30	4	LT5	40	1.5	TAC-1	135' OCF dipole
MI	K8CV	74,618	273	38	LT5	40,20,15,10			
MN	N0UR	249,908	483	68	LT5	40,20,15,10	3.5	HW-9	3 el yagi, dipole
	W0QG	16,076	62	14	LT5	40,20	2	K2	Horizontal loop
MO	WA0OTV	1,665	111	15	GT5	15	2	TS530S	Indoor dipole 7' off ground
MT	AC7GM	5,035	5	1	LT5	20	0.5	Red Hot NC20	G5RV
NH	W1PID	3,850	55	10	LT5	40,20	0.75	MFJ Cub	OCF dipole 136'
NJ	W2AGN	134,760	280	56	LT5	80,40,20,15,10	4	K1, K2, Sierra	180' Zepp, KT34
	W2JEK	22,056	84	12	LT5	40,20,15	2.75	OHR500	Dipole & Ground Plane
	N2YVF	14,282	102	13	LT5	40	3.5	ARK-4	Dipole
	AA2YO	13,400	70	8	LT250	40	4	HB	
	W2QU	9,520	85	16	LT5		3	TS850S	Butternut Vert
OH	KB8X	16,270	115	14	LT5	40	4	OHR100A	G5RV @ 35'
	AB8FJ	6,050	30	5	LT5	40	1.5	SWL-40	Random wire
OK	K5DP	158,150	307	45	LT1	40,20,15,10	4	HW9	40 m horiz loop
	N5UW	68,212	252	33	LT5	40,20	3	OHR400	TA33 & Butternut vert
ON	VE3ZT	29,295	155	27	LT5	80,40,20,15,10	2		
PA	W3TS	48,760	88	18	LT250	80,40,20,15,10	1	HB Superhet Xvr	Inv Vee & 2 el yagi
	WB3AAL	27,680	162	14	LT1	40	3	SW40+	HF9V
	W3DP	24,950	190	15	LT5	40	2.25	OHR100A	G5RV
	KF3DY	567	27	3	LT5		0.5	MFJ 9040	Inv vee
	N3CZB	560	20	4	LT5	10	2	Century 21	
SC	W3RDF	191,994	399	58	LT5	160,80,40,20,15,10	4	K2	Quad
WJ4P	156,535	237	37	LT250	160,80,40,20,15,10	3.5	K2	OCF 80 m dipole	
TX	K5ZTY	399,260	602	90	LT5	40,20,15,10	4	K2	C4S
KI0G	25,704	153	24	LT5	40,20,15,10	4	QRP+	Long wire	
	KK5PJ	24,800	110	18	LT1	20	3.5	SW20	6 el yagi
	K5HWT	6,190	34	5	LT5	20	1	SW20	Dipole @ 24'
VA	KK4R	47,550	186	25	LT5	80,40,20	3.2	NC40A, DSW80, OHR100	Doublet
	WA4CHQ	8,080	44	7	LT1	40	1.5	DixiePixie	dipole
	N4UY	7,744	49	8	LT5	15,10	3.5	GM10, GM15	Wire dipoles in attic
WA	N7RVD	111,728	273	48	LT5		2	K2	3 el yagi @ 45'
	W7JRK	44,800	200	32	LT5	15,10	3.25	TS680V	Delta loop
WI	K9OSC	48,825	279	25	LT5	20	3.25	TS450S	D4 rotatable dipole @ 20 ft

(Check log: WD4IFN)

[www.qrparci.org/](http://www.qrparci.org/)

burger, but will do it again anyway. KX7L—I didn't quite make the 15 hours (got about 13 in). The rate meter was usually in the 30-40 zone during S&P, but dropped immediately to 25 when I started calling CQ. N2TPA—Seems like conditions were too good. Primarily, all I could hear was west coast stations. I had to hunt to find sections near me. N4ROA—Hey! What a blast. Thanks to ARCI for promoting the Bull thingie. It made me operate much more than I would have, therefore, much more fun. N6WG—I operated on 40m only for the SS. Calling CQ was not very productive, so resorted to traditional S & P mode. I was really impressed with the ears of some of the A and B stations. N7IR—Personal best in the CW SS. Also highest percentage of QRP stations worked: 12.4%. N9SE—I worked about 19hrs of the contest using a trap dipole up 25' and K2. I S&P'd most of Saturday night. I tried CQing more on Sunday. W2XS—Had fun, but didn't work as many QRP stations as I would have liked. W4DU—Great conditions. A total of 15 QRP stations. I had good luck calling CQ, but not as many QRPers as I thought. W4FMS—Just completed my new Elecraft K2 in time for CW SS. As most noted, veryslow run rate competing with the big guns. Tnx ARCI for a great contest. I'll be in it again next year. W4IM—Many more 'Q' contacts this year than last. Only had 11 hours but called CQ a larger % than before. It was great to work so many QRP'ers! W4QO—Great Contest. Heard and worked many more Q stations this year but could not find K9IUA in ND for WAS! Oh well, always next year. W6RCL—I tried calling CQ a lot, but found it was difficult to hold a frequency. Several times QRO stations moved right in on me. Not exactly a Bull, not exactly a Matador! W8IW—Strong storms and a major power outage from 3pm Saturday until 11 pm on Sunday covering the total 30 hour SS period. W9FHA—Where were the Q stations? Most of the Q stations had great signals and ranked close to the big boys. WB3AAL—While running the contest on one computer I was working on the configuration on another and working on the EPA Calendar all at the same time. Do I get extra points for that? WD3P—Fun little contest in the middle of SS. Should have signed up as a Bull. WD5CBL—Back on air after 8 years. Mainly looking for states.

#### Mark your Calendars:

**Hoot-Owl Sprint**--May 27, 2001

**Milliwatt FD**--June 23-24, 2001

**Summer Homebrew Sprint**--July 15, '01

### 2001 Hootowl Sprint

**Date/Time:** May 27, 2001; 8:00 pm to 12:00 pm Local Time. CW only.

**Exchange:** **Member** - RST, State/Province/Country, ARCI Number

**Non-member** - RST, State/Province/Country, Power Out

**QSO Points:** **Member** = 5 points

**Non-member, Different Continent** = 4 points

**Non-member, Same Continent** = 2 points

62 April 01

**Multiplier:** SPC (State/Province/Country) total for all bands. The same station may be worked on more than one band for QSO points and SPC credit.

**Power Multiplier:**

0 - 250 mW = X 15

250 mW - 1 W = X 10

1 W - 5 W = X 7

Over 5 W = X 1

**Suggested Frequencies:**

	General	Novice
160 m	1810 kHz	
80 m	3560 kHz	3710 kHz
40 m	7040 kHz	7110 kHz
20 m	14060 kHz	
15 m	21060 kHz	21110 kHz
10 m	28060 kHz	28110 kHz

**Score:** Points (total for all bands) X SPCs (total for all bands) X Power Multiplier. Entry may be All-band, Single-, High-, or Low-Band. Entry includes a copy of logs and summary sheet. Include legible name, call, address, and ARCI number, if any. Entry must be received within 30 days of contest date. Highest power used will determine the power multiplier.

### Milliwatt Field Day 2001

**NOTE:** You do NOT have to run less than 1 watt to play in this contest! Usual QRP power levels are just fine. However, because this is a piggy-back contest on ARRL's Field Day you need to use their definition of SSB QRP which is 5 w PEP.

**Date/Time:** June 23, 2001 1800Z to June 24 2100Z CW, SSB, DIGITAL

**Exchange:** Same as for the ARRL contest. See May QST issue for exchange details and full rules.

**QSO Points:** Same as ARRL rules. Phone counts one point/QSO. CW counts 2 points/QSO. Digital counts 2 points/QSO. Power Multiplier: See ARRL rules. Multiplier based on transmitter power and power source.

**Bonus Points:** No special QRP ARCI bonus points. Just use the ARRL ones.

**Score:** Same as ARRL rules. Total number of QSO points times the power multiplier plus bonus points.

**Entry Classes:**

One watt or less - one operator

One watt or less - two operators, one TX

Five watts max - one operator

Five watts max - two operators, one TX

Club class

In short, use the ARRL rules and scoring then send me a summary sheet.

*The QRP Quarterly*

Entry must be received within 30 days of contest date.

### 2001 Summer Homebrew Sprint

**Date/Time:** July 15, 2001; 2000Z to 2400Z CW HF only

**Exchange:** **Member** - RST, State/Province/Country, ARCI Number

**Non-member** - RST, State/Province/Country, Power Out

**QSO Points:** **Member** = 5 points

**Non-member, Different Continent** = 4 points

**Non-member, Same Continent** = 2 points

**Multiplier:** SPC (State/Province/Country) total for all bands. The same station may be worked on more than one band for QSO points and SPC credit.

**Power Multiplier:**

0 - 250 mW = X 15

250 mW - 1 W = X 10

1 W - 5 W = X 7

Over 5 W = X 1

**Bonus Points:** For homebrew gear (per band) add 2,000 points for using HB transmitter, add 3,000 points for using HB receiver, or add 5,000 points for using HB transceiver.

**Suggested Frequencies:**

	General	Novice
160 m	1810 kHz	
80 m	3560 kHz	3710 kHz
40 m	7040 kHz	7110 kHz
20 m	14060 kHz	
15 m	21060 kHz	21110 kHz
10 m	28060 kHz	28110 kHz

**Score:** Points (total for all bands) X SPCs (total for all bands) X Power Multiplier + Bonus Points. Entry may be All-band, Single-, High-, or Low-Band. Entry includes a copy of logs and summary sheet. Include legible name, call, address, and ARCI number, if any. Entry must be received within 30 days of contest date. Highest power used will determine the power multiplier. ●●

#### The final decision...

on all matters concerning the contest rests with the contest manager. Entries are welcome via e-mail to [rfoltz@turbonet.com](mailto:rfoltz@turbonet.com) or by mail to:

**Randy Foltz**  
809 Leith St.  
Moscow, ID 83843

After the contest send your Claimed Score by visiting <http://personal.palouse.net/rfoltz/arcia/arcisum.htm>. Check the web page for 10 days after the contest to see what others have said and claimed as their scores.

[www.qrparci.org/](http://www.qrparci.org/)



## QRP ARCI STAFF

President/COB

**Jim Stafford—W4QO**

11395 West Road  
Roswell, GA 30075-2122  
(770)993-9500  
w4qo@amsat.org

Vice President

**Joe Spencer—KK5NA**

3618 Montridge Ct  
Arlington TX, 76016  
kk5na@quadj.com

Secretary/Treasurer and

Membership—Subscription/Renewal

**Mark Milburn—KQ0I**

117 E. Philip St.  
Des Moines, IA 50315-4114  
kq0i@arrl.net

Membership Chairman

**Dale Holloway—K4EQ**

438 Brookdale Drive  
Piney Flats, TN 37686  
Telephone 423-538-1555  
k4eq@arrl.net

Awards Manager

**Thom Durfee—W18W**

3509 Collingwood Ave. SW  
Wyoming, MI 49509  
wi8w@arrl.net

Contest Manager

**Randy Foltz—K7TQ**

809 Leith Street  
Moscow, Idaho 83843  
rfoltz@turbonet.com

## BOARD OF DIRECTORS

**Chuck Adams—K7QO**

Box 11840  
Prescott, AZ 86304-1840  
k7qo@hotmail.com

**Hank Kohl, K8DD**

2130 Harrington Road  
Attica, MI 48412-9312  
k8dd@arrl.net

**Jim Larsen—AL7FS**

3445 Spinnaker Drive  
Anchorage, AK 99516-3424  
al7fs@qsl.net

**Dick Pascoe—G0BPS**

Seaview House  
Crete Road East  
Folksestone, Kent CT18 7EG, UK  
dick@gqrp.com

**Joe Spencer—KK5NA**

3618 Montridge Ct  
Arlington TX, 76016  
kk5na@quadj.com

**Ken Evans—W4DU**

848 Valbrook Ct.  
Lilburn, GA 30247  
w4du@bellsouth.net

The club is now taking membership application and renewals via credit card - online - using the PayPal system. In fact, we prefer it. This is true for all applicants- *worldwide!* Simply go to the club web site, specifically, <http://www.qrparci.org/us2signup.html> and follow the instructions. Be sure to select the appropriate button for the area of the world you reside in (per box below).

PayPal replaces all previous methods of payments for non-US hams except that you may always send your payment directly to Mark Milburn, our treasurer; however, funds must be drawn on *a US bank and be in US dollars.* Make Checks out to: *QRP ARCI*

If mailing your application (if renewing, it helps to send in the mailing label from your QQ), send your application to:

**QRP ARCI—Mark Milburn, KQ0I**

**117 E. Philip St.**

**Des Moines, IA 50315-4114**

Need an *Information Pack?*

Send email to: [k3tks@abs.net](mailto:k3tks@abs.net), or...Send an SASE to:

**Danny Gingell, K3TKS**

**3052 Fairland Road**

**Silver Spring, MD 20904**

### TIPS:

1. Use the Online Member Lookup feature to keep track of your membership status—check <http://www.qrparci.org/lookup.html>
2. Is your data on file now incorrect? Use online form to send info to our database manager: <http://www.qrparci.org/input.html>

**USA—\$15 / Canada—\$18 USD / Non-US/VE—\$20 USD per year**

## New Member/Renewal Form

CALL \_\_\_\_\_ QRP ARCI# (or "New" if new member) \_\_\_\_\_

Full Name \_\_\_\_\_

Mailing Address \_\_\_\_\_

City \_\_\_\_\_ State/Country \_\_\_\_\_

Post Code (ZIP + 4 for USA) \_\_\_\_\_

Previous Callsign(s) (if any since you joined the club) \_\_\_\_\_

(The following is optional and is not released to others)

Email address \_\_\_\_\_

Comments \_\_\_\_\_

## **Become a Famous Author!**

### **Write a Review for the QRP Quarterly**

Have you just purchased a new gadget, rig or kit that you would like to tell the QRP world about? Then write a review and send it to the QRP Quarterly! Reviews are handled by our Special Features Editor, **Larry East—W1HUE** (see page one for address). We have no strict guidelines for reviews, but we do ask that you include the manufacturer's basic technical specs and any results of technical tests that you have performed. If you are not sure about some aspects of the device that you are reviewing, don't guess; ask the manufacturer for clarification. (We reserve the right to also contact the manufacturer for additional details or clarification.) Please try to be as objective as possible: tell about the good as well as the bad features. Larry prefers to receive articles in machine-readable form as ASCII text files on PC format floppy disks or as email attachments.

If you want to send word processor files, Larry can handle MS Word 6/95/97, WordPerfect 5/6 and "Rich Text File" (RTF) formats (please don't do any fancy formatting or embed graphics within WP files). Figures (drawings and photographs) can be supplied as "hard copy" (good quality, B&W or color prints for photographs) or as digitized images (GIF, TIFF, JPEG, PhotoCD, PCX or bitmap files). If you want your disks, drawings, etc., returned, please enclose an SASE with sufficient postage. ●●

QRP means something different to all of us, but I think conservation of energy is a part of its appeal. Our tiny radios draw 1/100th to 1/10th that of the HF rigs used by the average ham, and we think nothing of powering our entire stations from solar power or 8 AA-cells.

For those of us in California, this aspect of the QRP philosophy just went mainstream. We're under continuous threat of blackouts due to a failed deregulation of the power industry, and new power sources are slow in coming. Part of the problem is California's high rate of population growth. But as a society, we've gotten addicted to bright lights in unused rooms, multiple computers per person, dozens of things powered by wall-warts, and a stifling standard of home heating.

Fortunately there's a simple short-term solution, obvious to any veteran milliamp-counter: turn stuff off! A significant reduction in personal power utilization is possible without going totally

native.

In the long term, we can only hope that this crisis will foster a true revolution, with an emphasis on alternative energy sources and on conservation. Many people tried to start this revolution in the 70's,

their knowledge of energy efficiency beyond ham radio. Let's help our family, friends, neighbors, and colleagues do the right thing. Let's also tell the manufacturers of everything from air conditioners to Zip drives that low power consumption

just became their most important new feature. The U.S. Environmental Protection Agency even has a program to encourage the manufacture and purchase of equipment that meets certain efficiency standards (see [www.energystar.org](http://www.energystar.org)). As far as I can tell, there's no Energy Star category for amateur radio gear yet, but you can bet I'll be lobbying for one.

A lot of QRP gear uses decades-old analog technology. But next time you fire up your unpretentious little station, pat yourself on the back: our present and future energy

problems have put you right back at the cutting edge.

Wayne Burdick, N6KR, Elecraft ●●

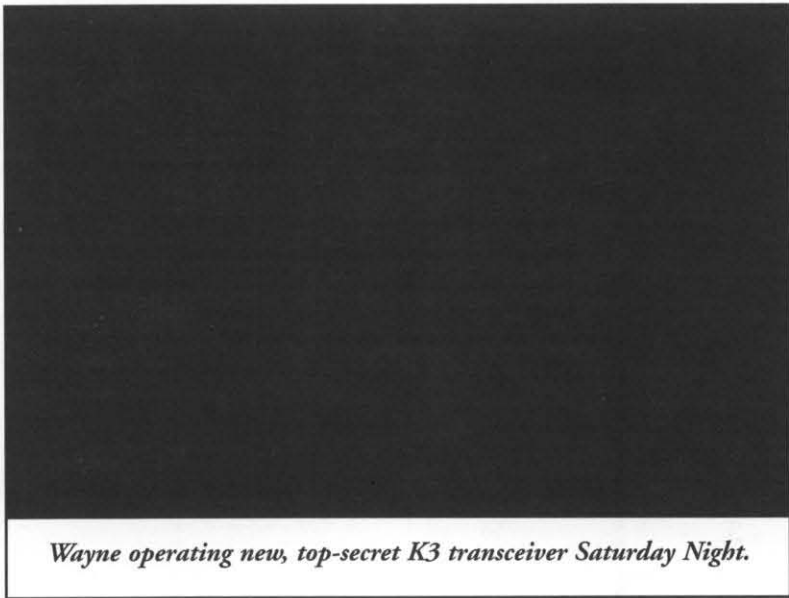

*Wayne operating new, top-secret K3 transceiver Saturday Night.*

but when the oil crisis ended, the incentives and enthusiasm dried up.

I'm hoping that QRPers in California, and elsewhere, will now start to apply

## The Last Word

The QRP Quarterly invites readers to submit original technical and feature articles as a service to their fellow QRP enthusiasts. Although The QRP Quarterly cannot pay for submissions accepted for publication, it will acknowledge, with thanks, authorship of all published articles.

Due to space limitations, articles should be concise. Where appropriate, they should be illustrated with publishable photos and/or drawings.

Full articles should go to any of the volunteer editors for review. Information for columns should be sent directly to the column editor. See the ToC for addresses. Submit technical and feature articles with a printed copy and a copy on disk (if possible). ASCII text is preferred. Photos and drawings should be camera-ready or .tiff format. Other formats can be used with prior approval.

Technical and feature articles should be original and not be under consideration by any other publication at the time of submission to the QRP

Quarterly or while the QRP Quarterly is reviewing the article. If you contemplate simultaneous submission to another publication, please explain the situation in a cover letter.

Material for possible use in the QRP Quarterly should be sent to only one of the editorial volunteers, not to several at the same time. The QRP Quarterly editors and columnists will transmit the submission to others on the staff if they believe it better fits another category.

Accepting advertisements for publication in the Quarterly does not constitute endorsement of either the product or the advertiser.

Material cannot be returned unless accompanied by sufficient postage.

The act of mailing a manuscript constitutes the author's certification of originality of material.

**Opinions expressed are those of the authors and do not necessarily represent those of the QRP ARCI, it's officers, Board of Direc-**

### tors, Staff or advertisers.

The QRP Quarterly will occasionally consider reprinting articles previously published elsewhere if the information is especially useful to members of QRP ARCI. If your article has been published, include the name of the publication and the issue it appeared in. In all such cases, the QRP Quarterly will obtain permission to reprint from both the author and the original publication and acknowledge the source of the material.

The QRP Quarterly will occasionally print information first appearing on QRP-L after obtaining the permission of the author and ascertaining that the information is not scheduled to appear in another publication.

Copyright of materials published in the QRP Quarterly remains with the author. Although the author retains the right to reuse the material, the QRP Quarterly requests that reprints of the material in other publications acknowledge first publication in the QRP Quarterly. ●●

**FDIM 2001**  
**Four Days In May**

**May 17 – 18 – 19 – 20 at the Dayton Hamvention**

QRP Amateur Radio Club, International (QRP ARCI), proudly announces the sixth annual "Four Days In May" QRP Conference commencing Thursday, May 17, 2001—the first of four festive days of 2001 Dayton Hamvention activities. Mark your calendar for these four days and register early for this not-to-be-missed QRP event of the new century. Amateur Radio QRP presentations, workshops and demonstrations will be the focus of the full day Thursday QRP Symposium to be held at QRP ARCI headquarters—the Ramada Inn Dayton South.

Here is a brief overview of the four days:

Thursday: QRP Symposium: 8:00 AM til 4:30 PM Contribution: \$15.00

Topics include:

“SMT Construction”—George Dobbs G3RJV

“Interference to Amateur Radio”—Ed Hare W1RFI

And more—monitor the QRP-F, QRP-I and QRP ARCI web site (<http://www.qrparci.org/>) for details on other presentations.

Thursday Evening: Author Social, 7:00 PM till 11:00 PM—No Charge

A chance to meet and talk with the QRP Symposium Speakers

Friday Evening: Vendor Social, starting at 8:30 PM—No Charge

Friday evening has been set aside for QRP Vendors. Here is a chance to eyeball the latest equipment and talk with the vendors.

Saturday Evening: QRP ARCI Awards Banquet\* - 7:00PM to 9:00 PM - \$25.00 per ticket

Saturday evening starts with the annual QRP ARCI Awards Banquet honoring QRPers who have made major contribution to QRP & Amateur Radio. We will also announce the winners of the various “build-it contests”. Fantastic “door prizes”, great speaker, tons of fun - be there.

(\* NOTE: This is a change from Friday to Saturday.)

Later on Saturday Evening: Display of the Building and Design Contests entries and winners, PLUS the Radio Show—FREE!

Saturday evening provides time for QRPers to socialize with the QRPers from around the world. Show off your projects and collections at the Radio Show!

All entries to the building and design contests will be on display. This year we have two general categories:

1. Wide open category - bring your latest homebrew or kit project.
2. The second contest is “in the works”. Monitor the QRP-F, QRP-I and QRP ARCI web site (<http://www.qrparci.org/>) for details.

Please use this form to register. Complete and send with a check made out to QRP ARCI to:

**Ken Evans**  
848 Valbrook Court  
Lilburn, GA 30047

<b># tickets</b>	<b>Name</b> _____
<b>FDIM Seminar</b> _____ @ \$15.00 = _____	<b>Addr</b> _____
<b>Awards Banquet</b> _____ @ \$25.00 = _____	<b>City</b> _____
<b>Total Enclosed</b> = _____	<b>Call</b> _____
	<b>E-mail</b> _____

(Please include e-mail address for confirmations.)

# High-Performance QRP Kits



[www.elecraft.com](http://www.elecraft.com)

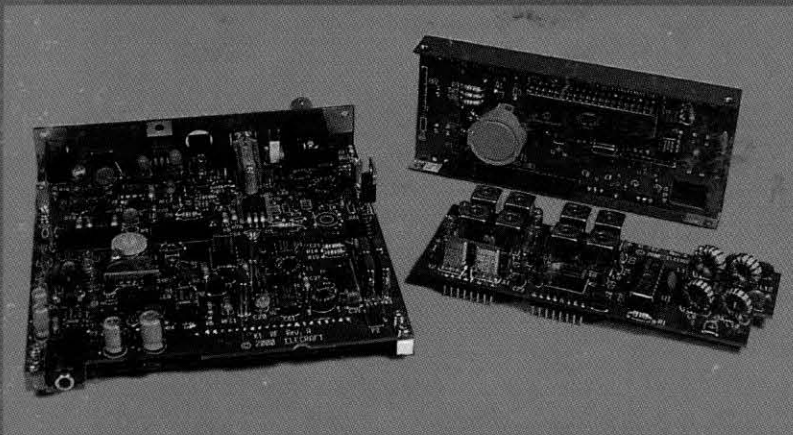

"I just have to say thanks...my K2 performed flawlessly on the Island of Abaco and during the CQWW CW Contest." – Ed, WA3WSJ

"This is such a beautiful piece of equipment. The attitude and performance of the people at Elecraft are outstanding, and reflected in the product!" – Allan, W6MEO

We're so busy designing exciting new kits for 2001 that we've decided to let our customers do the talking. Just ask anyone with a K1 or K2: they'll tell you about the hot receiver, excellent signal reports, no-wires assembly, and of course the *mojo* that seems to be built into every Elecraft kit. But if they get too emotional on you, visit our web site, where you'll find rational, objective information. See how our all-band, SSB/CW transceiver, the K2, stacks up against the world's best rigs. Check out the small size and versatility of the K1 dual-bander. Download a complete owner's manual. It won't be long before we'll have *you* talking, too!

 ELECRAFT

P.O. Box 69  
Aptos, CA 95001-0069

Phone: (831) 662-8345  
[sales@elecraft.com](mailto:sales@elecraft.com)

