

QRP Quarterly

Volume 43 Number 1

January 2002

\$4.95

Journal of the QRP Amateur Radio Club International

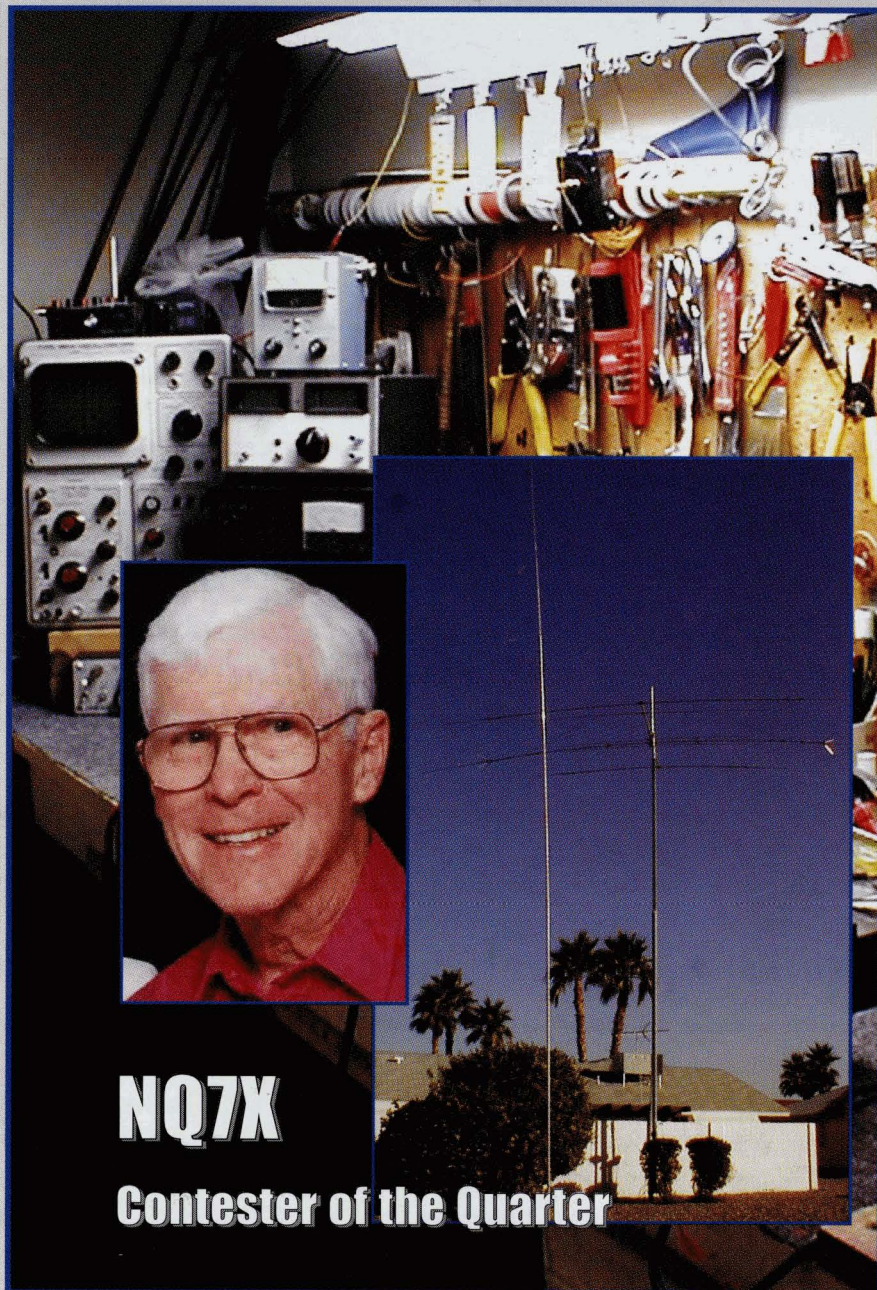

NQ7X

Contester of the Quarter

- *Who Comes Here?*
A Message from New
President KK5NA
- *Review* — Elecraft K1
4-Band Board
- Laptops for Field
and Hamshack
- More Digital QRP
Homebrewing
- Freddy's Fabulous
Frequency Finder



QRP ARCI is a non-profit organization dedicated to increasing worldwide enjoyment of radio operation, experimentation and the formation and promotion of QRP clubs throughout the world.

NEW From Patcomm



The PC-500 Dual Banders

For \$395.00 you get lots of built-in features such as both CW & SSB modes, an Iambic Keyer with our patented CW Keyboard Interface, adjustable 1 to 15 Watts of output power and Patcomms' unique DVF (Digital Variable Filter) filtering system providing a 600Hz to 2.8kHz continuously variable filter within the AGC loop for superb receiver selectivity. VOGAD and RF Clipping are used on SSB Transmit to provide that Big Radio "Punch". This radio can be ordered with your choice of any two Ham Bands between 160 and 6 Meters, and when ordered with the VOX option is PSK-31 ready. This is the ideal rig for QRP and Portable operation. **ALL THIS FOR ONLY \$395.00**

New Lower Prices on these Patcomm Radios



PC-9000 HF+6 Transceiver

Compact, rugged 40 Watt Ham Band Transceiver with our unique DVF (Digital Variable Filter) continuously variable filtering system and our patented CW Keyboard Interface. You get coverage of all HF Amateur Bands plus 18 Watts out on 6 Meters. Low power mode lets you operate QRP at 5 Watts output.

Reg \$799.00 (FM Adapter \$79) Now \$650.00 Incl FM Adapter !

PC-16000A HF Transceiver

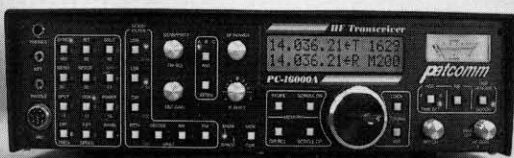

Reg \$1,749.00 Now \$1,295.00

100 Watt with General Coverage Receive. Collins IF Filters and DSP Audio Filtering make this an exceptional rig. DSP features include 5 "Brick Wall" filters plus Auto Notch and a De-noiser. Other features include our built-in patented CW Keyboard Interface and automatic CW and RTTY Decoder. Operates on CW, SSB and AM with output power adjustable from 1 to 100 Watts. Here is a full featured rig which is easy to use and delivers solid performance.

patcomm
corporation

Phone: (631)862-6511
Web: www.patcommradio.com
7 Flowerfield Suite M100

Fax: (631)862-6529
E-mail: patcomm1@aol.co
St. James, NY 11780

NEW MATH

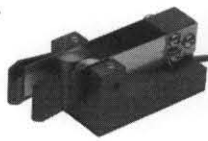

Miniature Paddle Key

Model PK-1

\$44.50



Iambic Keyer

Model K-4

\$54.00

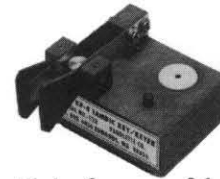

Key/Keyer Combination

Model KP-4

\$87.00

Excellent feel, fast, rugged.
Fine pitch adjust screws.
Magnetic bottom with 2 mates, RFI filter & 3' keyline. Only 1" x 1-3/4"; 1.5 oz.
Knee mount available.
(Add \$3.00 shipping)

12 functions with two 50 character memories. Has beacon mode, 4-year battery and RFI filter.
1-1/2" x 2"; only 1 oz.
1/8" mono & stereo jacks.
(Add \$3.00 shipping)

All the features of the Models PK-1 and K-4 in a lightweight, precision machined case.
1-1/2" x 2"; only 1.7 oz.
Knee mount available.
(Add \$3.00 shipping)

Send check or M.O. to: Paddlette Co. * P.O. Box 6036 * Edmonds, WA 98026. Sorry, no credit cards.
Shipping by U.S. Mail, first-class. Info: Bob, K17VY, Tel: (425) 743-1429, E-mail: bham379627@aol.com

NOTE: See our website www.paddlette.com for info on our new BP-K1 subminiature "backpacker" (BP) customized for direct attachment to Elecraft's K1 tilt stand.



MORSE Express

A Division of Milestone Technologies, Inc.

"Everything For The Morse Enthusiast"

- ✓ Keys ✓ Paddles ✓ Bugs ✓ Keyers
- ✓ Software ✓ Kits ✓ Books ✓ Tools

www.MorseX.com



Free Catalog

303-752-3382
2460 S. Moline Way
Aurora, CO 80014

A Division of Milestone Technologies, Inc.

Kanga US

New Products Available at Dayton:

- Hands Electronics RTX-109 - All Band SSB/CW Transceiver--6 or 20W version.
- R2Pro by KK7B - High performance DC RX module.
- DK9SQ Folded Vertical - All bands 80 - 10 including WARC. No Traps!
- Tormet Electronics VFO Module in a Clock Oscillator Module.

Coming soon from Hands Electronics:

- Monoband xcvr for PSK31/MFSK/RTTY for any band
3.5 - 50 Mhz

Still available:

- Spectrum Analyzer and Tracking Generator by W7ZOI and K7TAU
- R1, miniR2, T2, and LM2 by KK7B
- DK9SQ Mast, Loop, and Dipole
- Kits from Kanga Products, Hands Electronics, and Sunlight Energy Systems



Kanga US
3521 Spring Lake Dr.
Findlay, OH 45840 419-423-4604
www.bright.net/~kanga/kanga/kanga@bright.net

QRP Books

Quality Books for the Low Power Enthusiast

Antennas ♦ RF Design ♦ Reference Manuals
Operating ♦ Proceedings ♦ Measurement

21 Myers Heights Road Lansing, NY 14882

www.QRPBooks.com

Table of Contents

QRP Quarterly

Volume 43 Number 1—January 2002

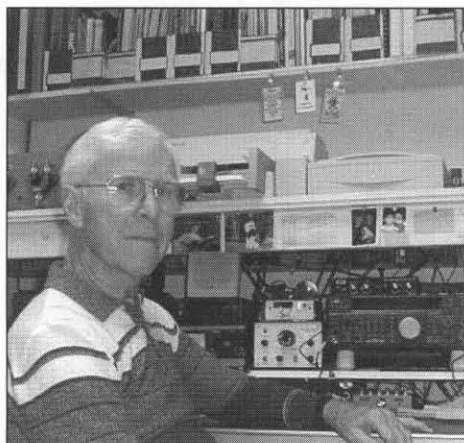

On the cover and page 37

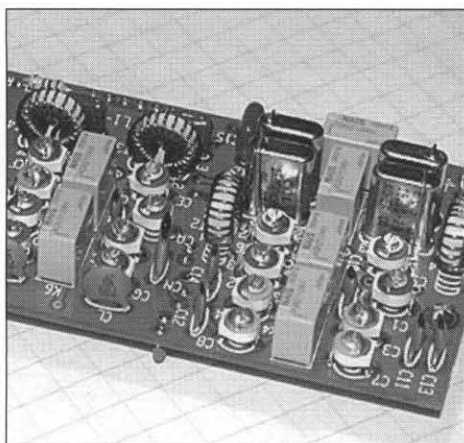

page 20

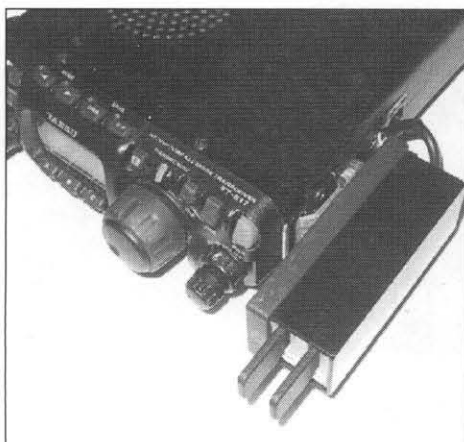

page 32

Technical

- 6 Idea Exchange—Mike Czuhajewski—WA8MCQ
 - Quickie No. 40: Vertical Base Connector* — Joe Everhart, N2CX
 - Losses in 50 vs. 75 Ohm Coax* — James Duffy, KK6MC
 - Inexpensive Source of 40M QRP Crystals*
 - Calibrated Dial for a 3-Turn Pot* — Tom Hamblin, VE3TMH/VA3HN/VE3HIE
 - Cheap (Free) Batteries* — W2EB, KB9OCE, WA8MCQ
 - Good Contact Cleaners* — N8YG, W6TOY, WA8MCQ
 - Japanese Transistor Coding System* — Tom Scott, KD7DMH
 - The NJQRP “Islander” Pad Cutter* — WA8MCQ
 - More Variable Capacitor Sources*
 - An RF Probe in a Small Phone Jack* — Brice Hornback, KA8MAV
 - Intermittent Alligator Clip Leads* — WA8MCQ
 - Soldering Fume Hazards, Lead Safety* — Stan McIntosh, KD4BTH
 - Noninductive Resistors Not Always for Dummy Loads* — WA8MCQ
- QRP Online
- 17 Test Topics and More... #10—Joe Everhart—N2CX
- 22 Laptops for the Field and the Hamshack—Preston Douglas—WJ2V
- 26 Digital QRP Homebrewing—Geroge Heron—N2APB
- 32 The FT-817-Paddle Combo—Dick Arnold—AF8X
- 32 “TOAST” – QRP Transceiver of the Near Future?—Petr Prause—OK1DPX
- 33 Freddy’s Fabulous Frequency Finder—Bill Currie—VK3AWC
- 34 QRV? Dah-di-dah-dit Dah-dah-di-dah—Mike Boatwright—KO4WX
- 46 One More Idea to Exchange—Mike Czuhajewski—WA8MCQ
 - Thoughts on Soldering Technique*—Danny Gingell, K3TKS

Operating

- 37 Floyd Smithberg—NQ7X, Contester of the Quarter—Randy Foltz—K7TQ
- 39 Adventures in Milliwatting—QRPP International—Jim Hale—KJ5TF
- 40 QRP Contests—Randy Foltz—K7TQ
- 45 Contest Announcements

Reviews

- 20 The KFL1-4 Four-Band Module for the Elecraft K1—T.J. “Skip” Arey—N2EI

Columns and Departments

- 3 Base Current—Jim Stafford—W4QO—QRP ARCI President
- 5 Who Comes Here?—Joe Spencer—KK5NA—Incoming QRP ARCI President
- 16 Ramblings of a Peaux Displaced Cajun Lad in Maine—Joel Denison—KE1LA
- 36 QRP Clubhouse-The Winter Doldrums—Mike Fletcher—KL7IXI/7

Miscellaneous

- 4 Announcements
 - Board of Director Nominations*
 - QRP Hall of Fame Nominations*
- 25 Four Days in May—Dayton Hamvention 2002
- 47 New or Renewal Membership Application
- 47 QRP ARCI Officers and Directors
- 48 IMHO—Ten Things I’ve Learned from QRP—Gary Breed—K9AY
- 48 The Last Word

QRP QUARTERLY EDITORIAL STAFF

Editor
(Position Open)

Associate Editor & Features
Larry East—W1HUE
15355 S. Rimline Dr.
Idaho Falls, ID 83401-5917
w1hue@arrl.net

Associate Editor & Idea Exchange
Mike Czuhajewski—WA8MCQ
7945 Citadel Dr.
Severn, MD 21144-1566
wa8mcq@erols.net

Associate Editor—Contests
Randy Foltz—K7TQ
809 Leith St.
Moscow, ID 83843
rfoltz@turbonet.com

REGULAR COLUMNISTS

Digital QRP Homebrewing
Geroge Heron—N2APB
2419 Feather Mae Ct.
Forest Hill, MD 21050
n2apb@amsat.org

Milliwatting
James L. Hale—KJ5TF
HCR 65 Box 261B
Kingston, AR 72742
kj5tf@madisoncounty.net

QRV
Mike Boatright—K04WX
1013 Latham Rd.
Decatur, GA 30033
ko4wx@mindspring.com

Test Topics...and More
Joe Everhart—N2CX
214 NJ Rd.
Brooklawn, NJ 08030
n2cx@voicenet.com

Neat New QRP Stuff
Greg Buchwald—K9QI
161 Lill Av.
Crystal Lake, IL 60014
agp002@email.sps.mot.com

QRP Clubhouse
Mike Fletcher—KL7IXI/7
Poulsbo, WA
kl7ixi@attbi.com

peaux displaced cajun lad...
Joel M. Denison, Sr—KE1LA
POB 542
Strong, ME 04983-0542
hamjoel@juno.com



Base Current

Jim Stafford—QRP ARCI President

w4go@arrl.net



Time flies when you're havin' fun! Hardly seems like 27 months ago that I became your president. My first "official" action was to attend the Pacificon hamfest and QRP bash in Concord, CA in late 1999. What a great event. Wish I could have gone again. That was the first of quite a few "official" activities as the president. All of which as I recall were quite enjoyable. The club has made some great strides during these 2+ years. Wish I could take the credit but it a truly amazing bunch of volunteers that make it happen. Our flagship product, the *QRP Quarterly* has grown in stature during that time under the successive (and successful) leadership of KU7Y, NA6E, and NM4T. The magazine has received rave reviews from just about everyone I come in contact with. Unfortunately for you and me, all these folks have moved on as they say and left us with no one to continue at the helm of the magazine. Although I have acted as the interim "caretaker" for this issue, hopefully we will have found someone to take over by the time you read this. If not, please at least inquire about the position. It is a big one but not totally overwhelming and we need to continue with a great QQ.

I think it is through the evolution of the magazine that we have also seen our membership (I should say our paid membership—once a member and always a member) grow by about 20% to nearly 2000. Our actual membership numbers have recently passed 11,000 with the membership of KD7OHW of Chandler, AZ. This kind of support is a simple indication of the raw attraction of QRP in the amateur ranks. We find a full spectrum of members from brand new hams to seasoned old timers. Thanks for staying active in the club.

When I came into this position, I had several goals. Not all were met but many have been. Here are a few more: we have 1) a club callsign—K6JSS; 2) a club kit in the form of the QRP Cub Project; 3) an Action Team who jump in regularly to take

on a project; 4) a more dynamic website, with member lookup, PayPal membership payments, a QRP forum online, and online voting. Our contest department has grown to add several new contests for QRPers and to attract other QRO ops to our ranks. This includes PSK31 contests, 160 meter QRP, and the Running of the QRP Bulls. By the way, this late info in from K7TQ who made all these new contests as well as the "old" ones possible—our winner for the chief "bull" was N0UR while K5ZTY and K7TQ (yes, Randy) snagged the most "bull." Congrats to all who worked some stations during the ARRL CW SS and sent in their logs. During these two years, we have seen record numbers of attendees at the club's Four Days in May festivities at Dayton, with nearly 400 each year participating in some fashion. Thanks to W4DU for heading up these great events.

I can not overlook the hard work of our Directors—those folks who serve 4 years (or try to). These folks do a lot more than simply decide on the "policy" of the club. Most are involved in some way or another with the "cook and bottle washing" activities of the club. I've already mentioned W4DU (FDIM), then there was K8DD (Toy Store), Joe Spencer (VP as well as a director). AL7FS, K4AHK, and G0BPS also pitched in when needed with the various chores. Thanks to these chaps who (again) made my job easy. You'll have a chance to endorse 3 directors to serve our club for the next four years. Just check the web site. Lastly, I would like to thank (again) Mark Milburn our very able Sec/Treasurer for doing a very big job handling all the membership-subscriptions-renewals and the database for all of us. There is so much to that job that I can't possibly do it justice.

Now to the future, Joe Spencer, KK5NA, our current VP, is now your new President and CEO. Congratulations, Joe. You are in for the ride of your life. I know you will have many exciting new ideas for the club and again it is the volunteers including all the writers for QQ and the Action Team that make it all possible.

Thanks again for making this such a great ride and remember, "The Thrill Is Back." ●●

Announcements

Board of Director Elections

Candidates have been nominated and agreed to serve for the club's Board of Directors for terms beginning April 1, 2002 and serving for 4 years. The current incumbents completing their terms on April 1 are: Hank Kohl, K8DD, Joe Spencer, KK5NA (the new club president), and Bill Harding, K4AHK.

Those standing for election follow. A short statement from the candidates is included here. A full statement is included on the web site. You may send in your ballot via US mail or you may vote online at <http://www.qrparci.org>. You must be an active, paid up member to vote by either method. Use the lookup feature on the club web site to see the status of your membership. Votes must be postmarked by February 28, 2002.

Tom Dooley, K4TJD Norcross, GA

I have been a ham since late 1996, definitely not a long timer in the Amateur Radio world! In spite of that, I have played with electronics for many years.

I built my first Heathkit in 1969, a FET VOM. I have built over 25 Heathkits, but none of them were Amateur Radio products. Although I loved electronics, I never knew a Ham radio operator while I was growing up...bummer. I loved electronics enough to sign up in the Air Force in 1972 for Airborne Communications training. I worked on C-124s and C-130s during my military career. I got out of the military in 1978 and college about the same time and got my CPA certificate in 1981.

I have served many roles in many model aviation clubs with the longest term being Treasurer of the International Radio Controlled Helicopter Association (IRCHA) from 1989 to 1997. I was the President of IRCHA from 1997 through 1999.

If I become part of the leadership team of QRP ARCI, I would like to work toward continuing and growing the relationship with the ARRL, to both of our benefits. No one organization is a successful island by itself. We must be well connected to grow.

I also feel that my experience will bring additional strength to a group that is already strong. I would love to step up to the plate to learn from the group and to participate in continuing the growth of the QRP ARCI organization.

Danny Gingell, K3TKS Silver Spring, MD

I have decided that I will place my name on the ballot for QRP ARCI Board of Directors for 2002. I have previously served as The QRP ARCI Net Manager for many years and also several terms on the BOD. I am currently managing The *QRP Quarterly* back issues sales and Services, sometimes called the warehouse. I will bring continuity and experience to the New BOD. We are growing as a Hobby and as a Club. It is very important that we keep new members in mind as we consider new directions and plans for QRP ARCI and QRP in General. I believe that I can help keep QRP ARCI on track and continue to lead the QRP Community into the future. I am a LifeTime QRPer and I WILL VOTE on every issue presented to the BOD, just as I have in the past.

Hank Kohl, K8DD Attica, MI

I am currently serving on the Board of Directors and have done so for the past 8 years.

As a nominee for the Board of Directors of QRP-ARCI I hope to help keep the club moving forward. The big thing is to keep QRP-ARCI in front of the rest of Amateur Radio and spread the word that "QRP is!" and "Life is NOT too short for QRP!" Also to support the many events that ARCI helps sponsors. I currently manage the Toy Store—all the club items such as books, tee shirts, etc. I also manage all the rooms for FDI. I will bring continuity to the club.

QRP Hall of Fame Call for Nominations

It is the proud honor of QRP ARCI to announce the 2002 QRP Hall of Fame. It is

now time to submit your nominations for this prestigious award. If you feel someone has had a significant impact on the QRP community through outstanding accomplishments (technical, operating, organizational, etc.), they would be a candidate for this honor.

It is important to do more than simply tossing out a name. We need to have a few paragraphs giving some details of the accomplishments, telling us why the person is worthy of being in the QRP Hall of Fame. Don't count on all of the voters knowing everything about your favorite QRP hero; you think they are worthy of the honor and it's your duty to convince us—the voters. The award is sponsored by QRP ARCI, but a nominee need not be a member of the club. The voting body consists of officers and board members of QRP ARCI, along with recent winners of the award. Winners will be announced at the banquet during the Four Days in May activity at Dayton on May 18, 2002.

While we have no list of specific requirements to meet for induction, we do have some guidelines. In general, nominees should be someone who has made significant contributions to QRP in one or more areas, and preferably things benefiting a large number of people. Long term contributions carry more weight than limited, short term ones. Nominees have a much better chance of induction if they have been actively serving the QRP community for an extended period of time, i.e., several years. Naturally, the nomination letters should only include information on achievements that are related to QRP. There are no quotas and no limits. If the voters don't feel that any nominees truly deserve the honor this time around, no one will be inducted simply for the sake of having someone to announce at Dayton.

Last year's winners were George Heron, N2APB and Peter Zenker, DL2FI. A full list of past winners and other information about the QRP Hall of Fame may be found on the club web site. Nominations should be forwarded (preferably by email) to Club Secretary Mark Milburn, KQ0I@arrl.net, 117 E Philip St., Des Moines, IA 50315-4114. ●●

Who Comes Here?

Joe Spencer—KK5NA, Incoming QRP ARCI President

kk5na@quadj.com



This past year seems to have flown by. Seems only a short time ago I was writing about being the new vice president and suddenly I am the president of this great organization. I bid Jim a

trepidacious farewell as president. He has done such an excellent job during his term and has left me with some large shoes to fill! Thanks for all your great work, Jim, over the last years as a director, VP and especially as President. I hope you will stay around, stay active and be there to advise us as we take QRP ARCI into the future.

We are fortunate to have an on-going group of excellent volunteers manning the many areas of leadership/stewardship of this organization. There are now vacancies on the Board of Directors and we also need a new Vice President. If anyone is interested please let us know and we will get you into the nomination process.

I am very excited about the future of QRP and QRP ARCI. QRP is the fastest growing part of Amateur Radio and is constantly gaining more recognition by the world as a significant community in this hobby. As you know QRP is being addressed and targeted by the Radio manufacturers, magazines, publishers of books and major radio organizations. Most contests have a QRP category and now the ARRL has a QRP DX award. Things are happening!

The title of my column, "Who comes here?" is meant to represent the fact that all who come to QRP may now find something for themselves. It has become an open and diverse part of the hobby to ALL who wish this kind of experience. Where it used to be an area requiring die-hard perseverance and extreme technical skills, it is now possible to build very good transceivers from kits or from scratch. And there exists a great deal of local, written, and on-line technical help and knowledge readily available to all to aid at every step of the process. There are more and more

avenues of QRP for all types of amateurs to pursue, digital, phone, cw, satellite, and ATV.

The more hams that experience QRP, through clubs, Hamfest presentations etc., the more hams that become QRP ops.

These events have come about due to you (the QRPers) and to the work of many people, Jim Stafford, Doug Hendrix, Ed Hare, George Heron, George Dobbs, and many, many others who preach, demonstrate, and live QRP. QRPers show the world that great things can be done with low power, that great radios can be made into kits and built and operated by anyone and at a reasonable price. They demonstrate the way this hobby is meant to be. Their relationships with each other, their approach to operation—friendly competition, helpful clubs/organizations that value their members and are not political organizations full of cliques and special interest areas for a few members.

With that said, back to QRP ARCI. Craig has done a fantastic job with the QQ but he is unable to continue in that role. The Quarterly will go on and will still continue to have the excellent content it has had in the past. The QQ is filled with the best articles every month! It seems that each page has something interesting to read and/or try. We are blessed with many excellent contributors each month. Jim and Larry are doing the work on this issue and will provide details on the future of the publishing of the magazine. Mike Czuhajewski produces the Idea Exchange and it continues to be a great source of ideas and information. Randy Foltz, K7TQ has been keeping the QRP Contests filled with good events. Thom, W18W is doing a great job with the Awards, Steve, N4EUK has our membership flying high, and Mark, KQOI does a fantastic job as secretary/treasurer...what a big job that is...but he makes it seem easy.

We have a very good Board of Directors that helps keep us on the "straight and narrow" and guide us in the day-to-day operation, thanks to them for a great year and I look forward to the next one. Hank, K8DD of course manages the "Toy Store" and keeps available all the neat QRP goodies we sell. I have probably

forgotten someone, so let me apologize in advance, but know that I am pleased to have each of the many talented, devoted and energetic people to work with.

I am not technically "retired" as Jim is and my time not quite as flexible, but I hope to be able to devote the time necessary to do a good job as president.

I hope to get the QRP community to pull even closer together and continue to prosper.

As you know we have an Action Team that does "one-shot" tasks for the club and helps advise or perform research, etc. Contact Jim for information on joining the Action Team.

I hope that Jim will continue the fine work he does on the website. It is an excellent source of information about QRP ARCI and QRP in general with links to many other great sites.

There are many things coming up this year, Four Days in May at Dayton, the QRP Hall of Fame for 2001, many contests and events, Pacificon, Atlanticon, Arkicon, HAMCOM, and many more, it won't be a boring year for sure.

I must admit that I don't have much information about FDIM 2001 as yet, but I am sure it will be as good as it is every year, I hope to get there this year, for the first time!

The QRP ARCI has a great group of people that keep it doing such a great job and providing quality QRP information, representation and fraternity. I look forward to serving as the president and working with them to continue serving you the members. This club, as any club should be, is subject to the will and pleasure of its members. Let us know what you think, what you would like to see happening, or better yet get involved! ●●

FOUR DAYS IN MAY

*The Greatest QRP
Experience of the Year!*

Dayton, Ohio
May 16-17-18-19, 2002

Info at: www.qrparci.org

Idea Exchange

Technical Tidbits for the QRPer

Mike Czuhajewski—WA8MCQ

wa8mcq@erols.com

IN THIS EDITION OF THE IDEA EXCHANGE:

Quickie No. 40: Vertical Base Connector — Joe Everhart, N2CX

Losses in 50 vs. 75 Ohm Coax — James Duffy, KK6MC

Inexpensive Source of 40M QRP Crystals

Calibrated Dial for a 3-Turn Pot — Tom Hamblin, VE3TMH/VA3HN/VE3HIE

Cheap (Free) Batteries — W2EB, KB9OCE, WA8MCQ

Good Contact Cleaners — N8YG, W6TOY, WA8MCQ

Japanese Transistor Coding System — Tom Scott, KD7DMH

The NJQRP "Islander" Pad Cutter — WA8MCQ

More Variable Capacitor Sources

An RF Probe in a Small Phone Jack — Brice Hornback, KA8MAV

Intermittent Alligator Clip Leads — WA8MCQ

Soldering Fume Hazards, Lead Safety — Stan McIntosh, KD4BTH

Noninductive Resistors Not Always for Dummy Loads — WA8MCQ

QRP Online

Quickie #40: Vertical Base Connector

Since he missed an issue or three in the early days, Quickie #40 from QRP Hall of Fame member and New Jersey QRP Guiding Light Joe Everhart, N2CX, represents a little over ten years of an unending string of technical quickies for QRP Quarterly readers. This issue's installment presents a quick and dirty base for portable antennas.

In the past several years thickets of portable vertical antennas have sprung up every weekend across the country. They

are not germinated from the seed of red fruit but from mail order catalogs specializing in outdoor sports and endeavors. In short, the unorthodox use of telescoping fishing poles has spread by efforts of a modern-day Johnny Appleseed from Missouri.

I certainly have used my share of them! Beginning with the South Bend and Cabelas 20 footers, then the 14 footers from Cabelas, lately I've also used some inexpensive 10-footers from Wal-Mart and a couple of PVC pipe trials as well. One

common need for all them is a base connector to terminate element wires and the necessary ground radials, connecting them to a coax feedline. This Quickie describes my favorite solution.

Figure 1 is a top view of the base connection plate while Figure 2 shows the bottom. It's an octagon made of .062 inch (1/16") double-sided copper clad pc board stock. There are connection points at each of the eight vertices for ground radial attachment. Three of the four flat faces hold additional connection points. On either side of the center are two ceramic standoffs for support of a loading coil and for connection to the vertical wire and coax connector. The latter is a BNC mounted near the third flat face for coax feedline attachment.

Figure 3 shows details of the base plate. It is not an equilateral octagon. Symmetrically around the center, the four flat sides are dimensioned to 2-1/2 inches. This gives enough clearance for the ceramic standoffs and the BNC connector. The eight vertex holes are about 5/32" to clear 6-32 hardware. Ceramic standoff holes are 1/8" for the 8-32 hardware used. The BNC connector hole is D-shaped to prevent rotation of the connector as described in an earlier Quickie. It begins as a 1/4" round hole. A flat side is made on one side of the hole then the remainder is opened up with a rat-tail file to accept the threaded base of the connector.

The center hole diameter is whatever you need to fit over your vertical mast. The one in Figure 1 is about 1-3/4 inches for use with a 1-1/4 inch PVC mast. In use, the connector plate is held several inches above the ground by resting on several screws in the vertical mast (with PVC pipe) or by a Velcro™ strap wrapped around the mast. (See Figure 4.)

Ground-mounted verticals need a substantial number of ground radials to achieve reasonable efficiency. This is a case where size doesn't matter but quantity does. I've found that at least four are needed when I first adjust the loading coil. But for good efficiency a minimum of 8 is a good compromise. And if you can double

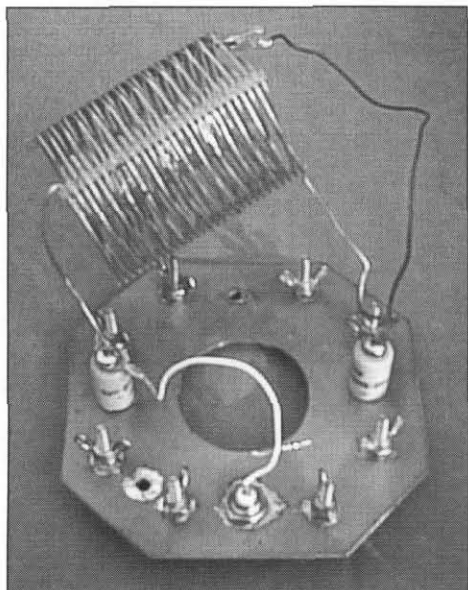

Figure 1—Top view of the base connection plate. The feedline connects from this side.

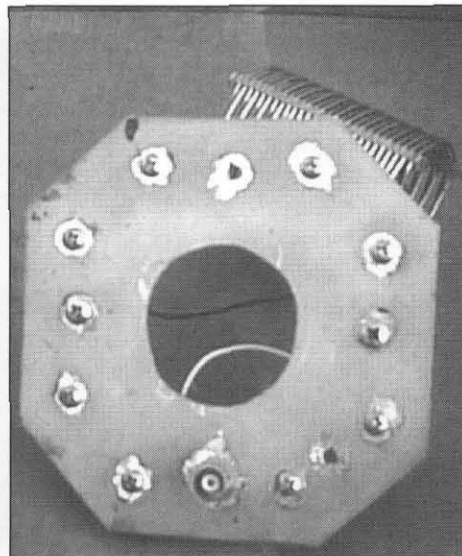

Figure 2—Bottom view of the base connection plate. The feedline connects from this side.

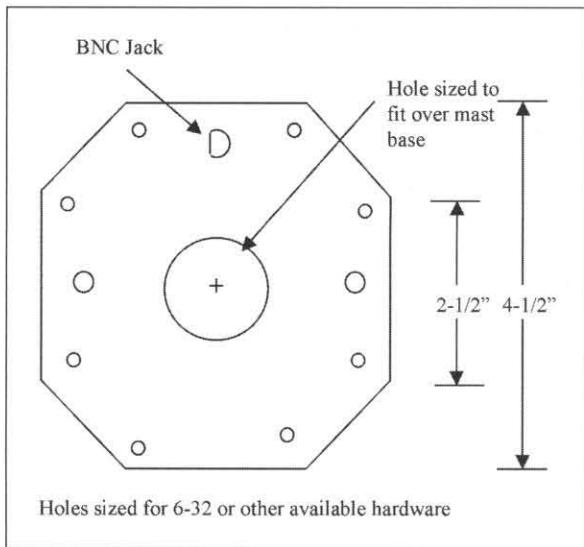

Figure 3—Details of the base plate.

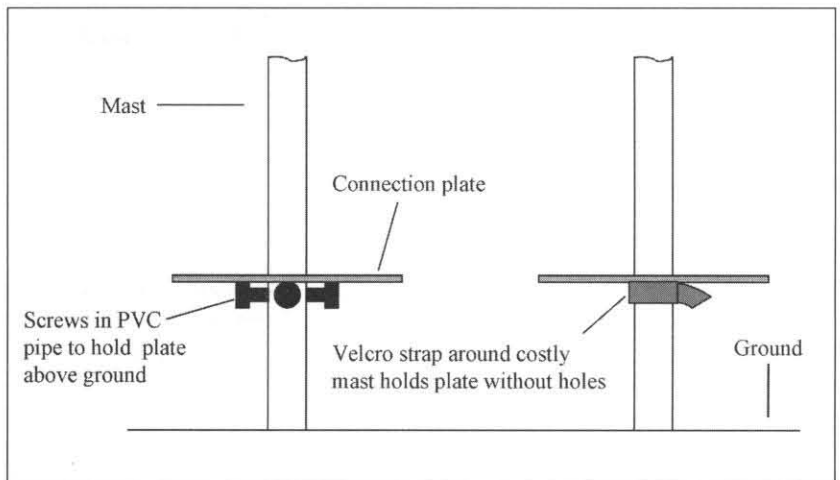

Figure 4—The base plate is supported by several screws around the mast if PVC pipe is used. For a mast that you don't want to put holes into, use a Velcro strap as shown at right [WA8MCQ drawing].

that number results should be even better. As many have found, the exact length is not critical particularly since proximity to ground detunes any radial resonance you try for. I compromise by making them about 16 feet long for 40 meters and up. If you use too few, your meager power will dissipate as inevitably as the usual byproduct of a beach beer blast.

Some care must be used in making sure that the base connector will stand up to the outdoor environment. The copper cladding will certainly oxidize very quickly. I tinned the surface around each hole to ensure that the hardware will have a low-resistance connection to both top and bottom surfaces. For the radial connection points the hardware stackup is a bolt through the plate, a nut on the other surface and a wing nut on top of that (Figure 5). This is adequate for connection to lugs on ground radials and use of wing nuts makes connection and disconnection easy without additional tools.

Alternatively you can terminate the

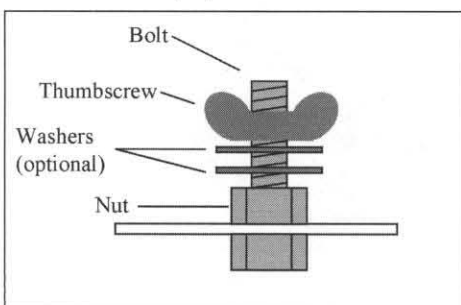

Figure 5—Use nuts, bolts, thumbscrews (and optional washers) to connect bare wires to the base plate [WA8MCQ drawing].

radials in alligator clips which are clipped to the bolts. If bare wires are to be connected, some flat washers between the nut and wing nut will have a better mechanical joint. The type of hardware used is important. I used 3/4-inch stainless steel bolts and nuts for the radial connections. I would have used stainless steel wing nuts but they were not available locally so I substituted pot metal instead. If you can find nickel plate brass that would be fine, too, but bare brass or ordinary steel hardware will corrode very quickly, giving very poor electrical connections.

The standoffs are nice ceramic jobs I scrounged from some surplus gear—actually, as I recall, an antenna tuner! A suitable substitute would be some round or square nylon or Plexiglas rod appropriately drilled and tapped. Wood is not recommended since it will conduct to the ground plate when damp. The Miniductor is likewise scrounged from one of the “anything for 50 cents” boxes at a hamfest. Making homebrew air-core inductors has been discussed in NorCal’s QRPP magazine by Dave Gauding, NF0R of the St. Louis QRP Society. The vertical antenna wire is connected to one of the standoffs by means of an alligator clip. A short jumper on the other terminal goes to another “minigator” clip used to short unused loading coil turns.

OK, that's the base connection for the fishing pole verticals. A future Quickie will describe several schemes I've used to secure the masts to the ground.

— de N2CX
n2cx@voicenet.com

Losses in 50 vs. 75 Ohm Coax

A while back on QRP-L someone suggested that 75 ohm coax (such as used CATV cable) was not the best choice for feeding ham antennas, suggesting that it may have more resistive loss as well as higher losses due to the impedance mismatch and increased SWR. James Duffy, KK6MC (“Dr. Megacycle”) of Cedar Crest, NM, had this to say in reply:

Comparing 50 ohm and 75 ohm coax with equal diameter center conductors and similar construction, we find that 75 ohm coax will have lower losses. The losses in a coax cable are given by:

$$A(\text{in dB}/100 \text{ ft}) = (0.435/Z * D) * [(D/d) * (K1+K2)] + \text{dielectric losses}$$

where Z is the characteristic impedance of the line, D the outside diameter, and d is the inner conductor diameter. K1 and K2 are braid and strand factors respectively which deal with the type of construction of the outer conductor.

The dielectric losses depend only on the dielectric used in the coax construction and the frequency of operation. They are independent of the characteristic impedance of the coax. They are usually unimportant at HF for the dielectrics found in most good quality coax. If you have a 19th edition of the ARRL *Antenna Book* you will find that this equation is essentially similar to Equation J in Table 2 on page 24-20. [It's the same page and table number in my 15th edition, but labeled as Eq. 10. —WA8MCQ]

Now, since Z appears in the denomina-

tor, the losses are inversely proportional to the line impedance. For lines of similar construction, 75 ohm coax will have lower losses than 50 ohm coax. This is also the reason why balanced feeders are thought of as lower loss than coax. Balanced feeders almost always have a higher impedance than the coax they are being compared with.

You can verify this by looking up the feedline losses for various coax types in the *ARRL Antenna Book* or *Handbook*. The difference is not great, a few tenths of decibels, but it is real.

What of additional losses for a 50 ohm antenna fed with 75 ohm coax? Consider a 10 MHz dipole fed with a 50 ohm feed point impedance. The SWR with 50 ohm coax is 1:1. For 100 ft. of RG-58 coax (such as Belden 8240), the line losses will be 1.1 dB. Now if we feed the antenna with CATV 75 ohm coax, RG-6, the SWR will be 1.5:1. The matched line loss will be 0.8 dB, and we must add in the additional losses due to the higher SWR. This information can be found in Figure 14 in the aforementioned *ARRL Antenna Book*. At an SWR of 1.5:1 and a matched line loss of 0.8 dB, the additional losses are off the bottom of the chart and will be much less than 0.1 dB! Call it 0.1 dB for the sake of argument. Now we have 1.1 dB losses for the 50 ohm coax case and 0.9 dB losses for the 75 ohm case. Not an earth shattering difference, but still it does not support the contention that the 75 ohm coax will be lossier.

Suppose that the antenna feedpoint impedance is 25 ohms, presenting a 2:1 SWR to the 50 ohm coax and a 3:1 SWR to the 75 ohm coax. The 50 ohm coax will have an additional 0.2 dB loss bringing the total line loss to 1.3 dB, and the 75 ohm coax will have an additional 0.4 dB loss bringing the total loss up to 1.2 dB. The 75 ohm coax is still better, but not by much; call it a wash. As the feed point impedance goes lower, the additional losses in the 50 ohm coax grow less fast than those in the 75 ohm coax. At a 10 ohm feedpoint impedance the losses are about equal, but at that point one should think about using some sort of matching at the antenna.

Of course with antenna impedances on the high side of 75 ohms, the 75 ohm coax will always have lower losses than the 50 ohm coax since the matched line loss is lower and the SWR grows faster on the 50 ohm coax than on the 75 ohm coax.

So I don't think that there is much to worry about when using RG-6 CATV cable, at least at HF. I am not sure that it gains a whole lot either, but it certainly will not lead to the excessive losses implied, particularly on 40M.

Of course there is some oversimplification in the above arguments, but the basic premise holds. For some reason transmission lines are one of the most misunderstood topics in ham radio. Perhaps because we all slept through high school trigonometry? I hope that this helps.

— de KK6MC/5
jamesd1@flash.net

Inexpensive Source of 40M QRP Crystals

Years ago, Doug Hendricks, KI6DS, and Jim Cates, WA6GER, co-founders of the NorCal QRP Club, took note of the fact that crystals could cost \$7.50 and up. It was obvious to them that it was not especially encouraging to QRPers who wanted to build and experiment with simple rigs. They decided to do something about it and placed an order for custom crystals for a QRP frequency and made them available at a reasonable price. (This is not something that you undertake on a lark since you have to lay down perhaps a couple thousand dollars to get a quantity large enough to keep the NorCal price down.)

The crystals are in the small metal holders with wire leads, and they've had a few different frequencies available over

the years. He currently has them available for 7040 and 7122 KHz. (They will soon add 14060 to that; Doug will post an announcement on QRP-L when those arrive. They used to have 10116, but those are long gone.)

The price is \$3 each postpaid. Doug requests that checks and money orders be made out to Doug Hendricks, not to NorCal. You can order from Doug Hendricks, 862 Frank Avenue, Dos Palos, CA 93620.

Calibrated Dial for a 3-Turn Pot

Multiple turn pots are great for QRP rigs with variable voltage tuning diodes since they really slow down the tuning rate. Calibration can be a problem, though; digital counter dials are available, but can be pricey and you'd have to have a calibration chart to interpret the numbers. Here's another approach from Tom Hamblin, VE3TMH, VA3HN, VE3HIE (who says they're allowed to hold up to 10 calls in Canada):

About a year ago I bought a NorCal 40A from my friend Brian, VE3VAW. It's a great little rig and I call it my K0. Because the tuning pot was a bit noisy and definitely faster than I liked, I decided to install a multiturn pot. I selected a 3-turn pot instead of a 10-turn unit because its tuning rate is more appropriate and a 3-turn pot can be directly calibrated.

The front panel picture (Figure 6) tells the story. There are 3 concentric circles:

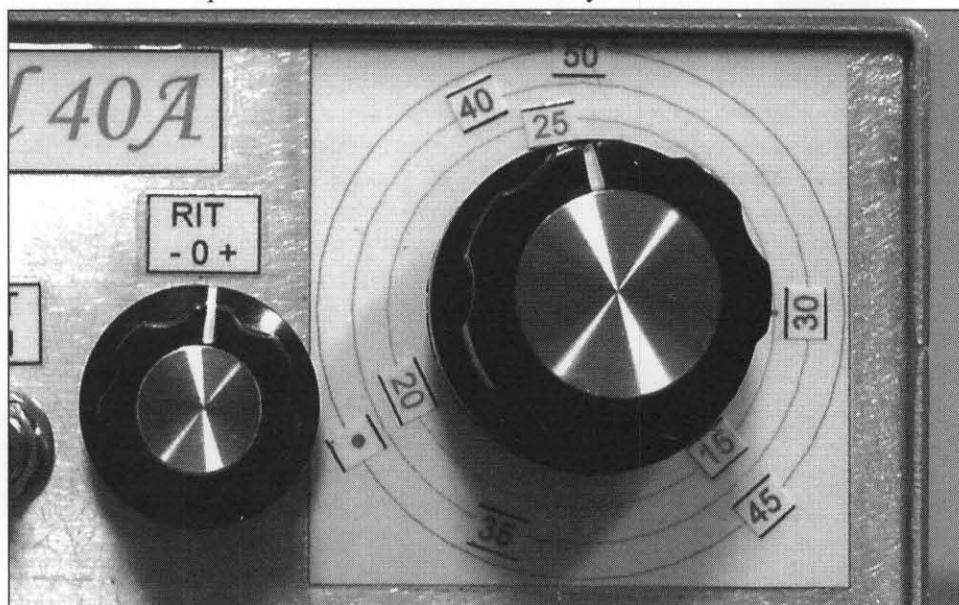

Figure 6—Three color-coded circles provide a handy dial for a 3-turn pot. Calibration points are indicated with matching colors. A dot on the outer circle marks the spot for W1AW.

red, green, and blue with calibration points every 5 kHz. The inner red circle covers 7013 to 7030. The center (green) covers 7030 to 7043 and the outer (blue) covers 7042 to 7051. I had another friend generate the circles in AutoCAD [a popular computer drafting program] and I printed them on a label sheet. Alternately they could be made manually with a compass and colored pencils.

Hidden behind the knob are crosshairs through the center of the circles. The horizontal red line at 0 degrees [barely visible at the 3 o'clock position, to the left of the number 30] marks the counterclockwise end of travel of the 3-turn pot. Similar pencil marks drawn on the front panel helped me center the concentric circles exactly on the center of the (enlarged) mounting hole. I also made a mark at the top of the label that is now hidden behind the 50 kHz calibration point. The top edge of the label exactly matched the top edge of the front panel. It took three tries to get it perfect. Print some extras!

The 5 kHz calibration points were made in Microsoft Word using a 1x1 Table and printed in matching colors on a label sheet. One of the calibration points is a blue dot on the outer circle to mark the 7047.5 kHz frequency for W1AW, a very useful marker. The other labels were also made in Word using 1x1 Tables. After trimming with scissors, the calibration points were carefully placed on the circles with the tip of an Xacto knife while listening to the output of the NorCal 40A on my Argosy 2. Finally, I covered the whole front panel with one layer of clear packing tape to protect the labels and calibration points.

In actual operation it is easy to remember and/or check whether the tuning pot is in its first, second, or third turn. Like I said, it's a great little rig!

— *de VE3TMH, VA3HN, VE3HIE hamblin@mirusinternational.com*

Cheap (Free) Batteries

Want a possible source of used but free rechargeable batteries? Here are some ideas:

From Bill Lazure, W2EB (n2tpa@juno.com) on QRP-L—It never amazes me how a thrifty person can get by nowadays. I wanted a battery backup for my equipment, but couldn't get the funds from the

XYL. After a few phone calls, I discovered that a large local burglar alarm company uses 12 V, 7.2 AH Gel Cells as a backup on their local alarm panels. They swap them out every two years, good or bad. A quick trip to the pallet in the yard, and I have a free back-up. Give it a try!

From Mike Truax, KB9OCE (KB9OCE@aol.com), also from QRP-L—Don't forget to feed your HT with free batteries, too. They can be had by the bagful at just about any 1 hour photo lab. They come out of disposable cameras and my tester shows them as good as new.

From me, WA8MCQ—A source of non-rechargeable batteries is used Polaroid Spectra instant film packs. We used the cameras quite a bit at work before we went digital, and generated a goodly amount of empty packs. But when the film is gone the small batteries in them still hold a fair amount of power. One of our senior technicians used to collect and use them all the time. While they aren't major powerhouses, they do provide useful power.

Along the same lines of the burglar alarm company replacing batteries regularly, hospitals do the same. My friend John Ward, W3OJ (ex-KA3GNG and AA3OJ), is a closet QRPer. Before he finished off his engineering degree and became an examiner for the Patent and Trademark Office, he worked for years as a medical technician at area hospitals. He used to provide local QRPer's with a steady stream of gel cells and lead acid batteries which were removed from various pieces of medical equipment. As with the alarm systems, they are replaced on a rigid schedule regardless of condition, and most of them were still quite good.

Good Contact Cleaners

QRP equipment uses potentiometers, switches and other things that can develop contact problems over time and require cleaning to restore proper operation. There were some recent recommendations on QRP-L:

From Brad Mitchell, N8YG (n8yg@yahoo.com)—Some time ago I was introduced to Caig Labs' Cramolin contact cleaner. My friend claimed that this stuff was great for cleaning old potentiometers, etc. I kept remembering using the TV tuner

cleaner that Radio Shack used to sell. You would spray it on, and a week or so later the problem was back.

Well, I finally broke down to search out the Cramolin product, only to find that Caig Labs no longer sells that particular item, but I did find some stuff called R5 Power Booster. I paid a lot for a small can, but I tried it on a bad pot about 2 months ago, and it's still working great. So if you have scratchy pots, don't give up—try R5 from Caig Labs.

Bruce Muscolino, W6TOY (w6toy@erols.com) said, "Caig is the supplier recommended by the boatanchor groups. It is trouble free and lasts! They use the Caig product DeOxit." [The "boatanchor" folks have an Internet discussion group about old, large, tube type ham equipment. — WA8MCQ.]

WA8MCQ note—I found this info on their web site, which contains a lot of information on their products:

CAIG Laboratories, Inc.
12200 Thatcher Court, Poway, CA 92064
TEL: 858 / 486-8388
FAX: 858 / 486-8398
E-mail: caig123@caig.com
WebSite: <http://www.caig.com>

Brad recommended the R5, while the boatanchor folks like DeoxIT. According to the web site, they are essentially the same product but with different solvents. Both use the same basic concentrate, but DeoxIT uses a petroleum naphtha carrier solvent, with drying time of 2 to 5 minutes, while the R5 uses DuPont Vetrel as a carrier, and dries in 10 to 15 seconds.

Some distributors of Caig products include Antique Electronics Supply (www.tubesandmore.com), RadioShack.com, MCM Electronics (www.i-mcm.com), and Techni-Tool (www.techni-tool.com). AES is one of the companies that still sells air variable capacitors. Techni-Tool is a well established and respected provider of hand tools and production equipment; we've dealt extensively with them at work for years.

Japanese Transistor Coding System

Here's one of those useful bits of information that deserve to be repeated every few years for benefit of the newer folks. If

you've ever looked at transistors in electronic equipment from the Far East you know that they use a system different from our 2N method, and it's more descriptive. Until you look up an unfamiliar 2N number you don't know if it's an NPN or PNP, audio or RF, or even an FET, but their part numbers have that coded into them. Here's a clue, posted to QRP-L by Tom Scott, KD7DMH:

I was sent this "decoder ring" of imported transistor part numbers and thought I'd share it with you folks. It may be helpful when trying to identify appropriate cross references, understanding a circuit you are troubleshooting, or scavenging parts to use for QRP. I had not realized they followed a pattern, but the ones I know of do seem to follow this key.

2SA	PNP	RF
2SB	PNP	Audio
2SC	NPN	RF
2SD	NPN	Audio
2SK	FET	
3SK	Dual Gate	FET
2SG	SCR	

I was told that this is several years old and may have been expanded by now.

— de KD7DMH
tomrscott@sterlink.net

Additional WA8MCQ info—While these don't tell a great deal about the parts, they do give some helpful information. For example, if you're trying to figure out which transistors in a junked VCR might make a good VFO or low power QRP amplifier and you want an NPN device, you know you can consider those starting with 2SC and ignore the rest.

Although I don't have the codes available for different types, I do know that diodes start with a 1 instead of 2. Also, these numbers are frequently abbreviated on device packages. For instance, a 2SC1824 might be marked C1824, 2SD486 might be marked D486, etc.

The NJQRP "Islander" Pad Cutter

Or, "Street Level Pads for the Manhattan Builder." A lot of QRPers are familiar with Manhattan construction, especially those who frequent QRP-L or who attend any of the major QRP gatherings around the country. Popularized in the QRP community by Jim Kortge, K8IQY,

it's a variation on "ugly construction" introduced years ago by Wes Hayward, W7ZOI. (That was in a QST article circa 1982, co-authored with his son, Roger Hayward, KA7EXM.) While that older method uses high value resistors as tie points, Manhattan construction uses small pads punched or cut out of PCB material and glued down onto a large piece of unetched PCB stock. These are then used for tie points.

This requires some method of cutting or punching out the pieces, as well as the mess of working with adhesives such as Crazy Glue or Super Glue (cyanoacrylate), along with worries about the heat of soldering melting the glue and making the pads lift up. Basil "Dov" Rabinowitz, AD0V of Brooklyn, NY, came up with the idea of cutting isolated pads directly on the base PCB stock, eliminating the glued pads. His article in *QRP Homebrewer* issue #6 from the NJ QRP club (August 2001) details the long trip between concept and reality, but in the end he found the perfect tool in a jewelry tool store. (At work we occasionally order things from jewelry tool catalogs. Not all of it is applicable to homebrewing, but they do have a lot of neat things.)

What he ended up using is shown in Figure 7, and is now available from the NJQRP Club as the "Islander" Pad Cutter (details follow later). George Heron, N2APB, sent me one to play with and it's a neat little tool. About 1-3/4" long and with a 1/8" shaft, it's a hollow, diamond tipped end mill. The 0.4" long working end is 5 mm outer diameter and 3.5 mm inner. It's coated inside, outside and on the end with tiny bits of industrial diamond. The concept is simple; put it into a drill press, rev it up and make a light plunge cut into the copper surface of the PCB stock. The tiny diamond chips on the end cut out a circle, leaving an isolated pad of copper in the center which is perfect for Manhattan construction.

Although they recommend using a Dremel cutter and the drill press accessory for it, and cranking the speed way up, I put it into a regular drill press in the machine shop at work. The belts on the drive were set for 540 RPM and I was too lazy to change it, but it worked well enough to get a quick feel for it. I experimented on a scrap of PCB material and the results are shown in Figure 8. A couple of transistors

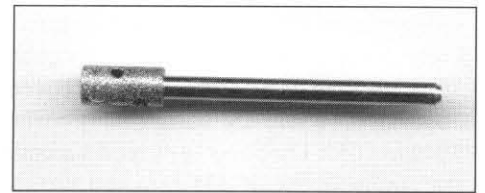

Figure 7—The "Islander" pad cutter from NJQRP, a diamond tipped tool for making "street level" pads for Manhattan construction.

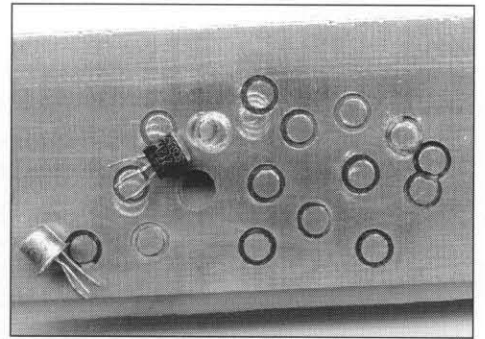

Figure 8—Some test pads made with the cutter, with a pair of transistors for reference. (Some of the rings are darker than others; I was having a hard time getting a satisfactory picture and was experimenting with darkening some rings with a marker for better contrast.)

give an idea of the size of the pads.

In use, cut down just far enough to completely break through the copper, and then stop. If your drill press has a depth stop, you can set that for repeatable holes. Be careful not to cut too deep, or you end up with a hole instead of a pad. After cutting a few and getting a feel for how deep to go (I did it manually each time), I deliberately kept on going to make a hole to see how hard it would be to do it by accident. It took a good while longer and I found that just doing things by ear and feel (and paying attention) is safe enough.

They do recommend using a drill press; as with any end mill, it's important that the cutter come down perpendicular to the board, otherwise it will want to walk off and be impossible to control. You also need to keep a good, firm grip on the board to hold it in place so it doesn't try to walk. If you have a drill press vise that will accept the size of board you want to cut, it wouldn't be a bad idea to use it. (As with any machine operation there is some possibility of injury; the article gives some safety tips.)

They mention using compressed air or a fine toothbrush for cleanup. I washed mine off instead, since it was already wet from cutting. The article included some notes from K8IQY, who said that he kept some water on the surface while cutting so that the copper wouldn't clog the cutter. I did my tests with water on the board and would never consider doing it dry. It helps keep down heating of the cutter if you do a lot of pads at one time, but the main benefit is that it also keeps the fiberglass dust in suspension instead of flying around and getting into your lungs and on your skin. After cutting, cleanup is as simple as washing it off, preferably in conjunction with a small brush; no worry about fiberglass poofle dust all over the workbench to make you itch! Washing also gets rid of the residual copper bits.

Since I didn't have a small brush handy and simply running water over it didn't get rid of all of the fiberglass sludge in some cuts, I took the point of a dull Xacto knife and ran it around the rings to help clean them out. Being at work I had the luxury of being able to examine the pads under a stereo zoom microscope to see if there were any copper filaments shorting things out. There were a few very small ones, but not big enough to worry about. Since the pad is only isolated from the main copper of the board by a very narrow moat, they recommend verifying isolation with a meter to be safe.

Unlike traditional Manhattan construction, the pad is at the same height as the surrounding board and not above it; this requires a little extra caution. Be careful when attaching wires and leads, to be sure solder doesn't bridge the moat and short it out. And be sure the leads soldered onto the pads don't extend over the moat and touch the ground plane beyond.

The NJ "Islander" Pad Cutter is available for \$9 postpaid in the US and Canada (\$2 extra for DX). Make check or money order payable to "George Heron, N2APB" and send to: George Heron, N2APB, 2419 Feather Mae Court, Forest Hills, MD 21050. (Or, send payment electronically over the Internet to n2apb@amsat.org via the PayPal system.)

(The basic idea of cutting isolated pads in PCB material has been around for a very long time. The *QRP Quarterly* had an article on it in October 1992, and even then it was far from new. In that issue, WA1MAC

detailed his use of an automotive repair tool, a spot weld cutter, which made the pads. I'll write about that in a future issue.)

— de WA8MCQ

More Variable Capacitor Sources

Someone asked about sources of these on QRP-L and Carl Seyersdahl, KZ5CA, recommended checking with Ocean State Electronics, which is a fairly well known supplier among QRPers. Pages 58, 59 and 60 of their online catalog have variable caps of several types. Their web site is at <http://www.oselectronics.com/cindex.htm>

Ray Colbert, W5XE, suggests trying the Crystal Set Society; their web site is <http://www.midnightscience.com/>

Old timers will remember the once ubiquitous 365 pF "broadcast" variables. These and similar ones with less capacitance were found by the gazillions in old AM and AM/FM radios back in my youth. In the last couple of decades they have totally disappeared from consumer electronics as technology advanced and electronic tuning took over. They still appear at hamfests now and then, or in dusty surplus houses, and a few years ago some folks had some new ones made by what is said to be the last remaining maker of variable caps in the country. At least some of the companies listed below sell these new caps, and all are sources of at least a few of these hard to find parts. Yes, prices are getting up there, but at least they ARE available.

The two firms mentioned above, plus Antique Electronics Supply of Tempe, AZ, have 365 pF variables. Some also have dual or triple section caps, 365 pF or more per section. To save you a bit of time, I've already done some comparison shopping at their web sites to give some idea of prices; these are current as of Thanksgiving day, 2001. (These are all of the "receiving" type for low power applications, although some companies also have "transmitting" variables of various types.)

Crystal Set Society: \$10.95, single 365 pF section, \$21.95, dual 365 pF sections (these are all the caps they have).

Ocean State: \$10.95 single 365, 19.95 dual 380 pF sections, \$19.95 triple 500 pF (plus others).

AES: \$11.95 single 365 pF, \$24.95 for triple section; plus others.

There may be other good sources of variable caps, but these are all that I can come up with at the moment. The AES web site is <http://www.tubesandmore.com>

— de WA8MCQ

An RF Probe in a Small Phone Jack

RF probes are simple—just a diode, capacitor and usually a resistor as well—and are quite useful in homebrewing. People have put them into a lot of different packages over the years, and here's one of the smallest and cutest I've ever seen. Brice D. Hornback, KA8MAV of Indianapolis, IN, announced his version on QRP-L recently and gave the link to his web page which contains the photos shown here. After he received feedback from myself and several others he expanded the text and added more photos and the schematic. What follows is the text from his web page.

This is the RF Probe I built for the QRP-L Elmer 101 (2001) Course. It's no secret I like to make things "tiny." As with most projects, I always have trouble finding just the right enclosure. This was no exception. I wanted something small, metal, and with a point on one end. I looked and looked but couldn't find the "perfect" enclosure. While I was sitting at my desk thinking and staring at my straight key, I saw something. There, right in front of me was the answer. A 1/8" shielded phone jack!

[WA8MCQ—The schematic is shown in Figure 9 and many homebrewers will recognize it instantly. The classic circuit has been around "forever" and has appeared in the ARRL handbook for decades.

The output from the junction of the

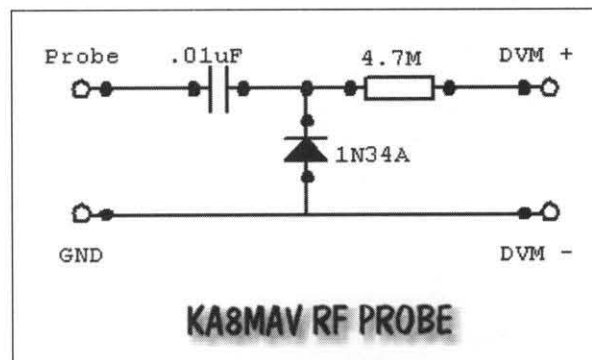

Figure 9—Schematic of the RF probe. See text for discussion of the value of the 4.7M resistor.

diode and capacitor is a DC voltage equal to the peak voltage of the signal applied. But the usual way of referring to AC and RF voltages is by the RMS value, which is 0.707 times the peak value. We could connect a voltmeter to this point and read the peak value, then multiply by 0.707 but it's simpler to use the resistor. It forms a voltage divider in conjunction with the input impedance of the meter such that the output is approximately 0.707 of the peak, and thus the numbers on the meter correspond directly to RMS with no conversion needed.

In the "old days" people used VTVMs (vacuum tube voltmeters), which had an input impedance of 11 megohms, thus the 4.7M resistor. This results in an output that is 0.7006 times the input, within 1% of the RMS value. Most people have been using digital voltmeters for quite some time, and these have an impedance of 10 megohms. Using the 4.7M resistor with one of those gives an output of 0.680, which is almost 4% off. For better accuracy with the typical digital voltmeters usually in use, the resistor should be 4.14 megohms. This gives an output of 0.7072.

That's a nonstandard resistor value, but you can hit it with a pair of resistors in series—3.9M and 240k are perfect. Another suitable value for the smaller is 220k, resulting in 4.12M, for an output of 0.708. Adding the extra resistor could be an unacceptable complication in a very small area, and the 4% error is not unreasonable. Alternately, if you have several 4.7M resistors to choose from, you could select the one closest to 4.14M as a compromise.]

Figure 10—The alligator clip jumpers aren't the best thing to use. Shielded cable would be better. But these were just sitting there and they make it easy to clip to the leads of my DVM. I simply clipped off one end of each. Note: Most alligator clip jumpers are NOT soldered to the wires. Pull back the rubber covering and check them first. Solder the clips to the wires if needed. These came from Radio Shack and were already soldered.

Figure 11— I used a gold-plated header pin as the probe tip. I first used a wire brush on my Dremel to clean the tip of the phone plug. Then I tinned it with solder. Once it was ready with a little glob of solder on the tip, I touched the header pin and the soldering iron to it to quickly solder it

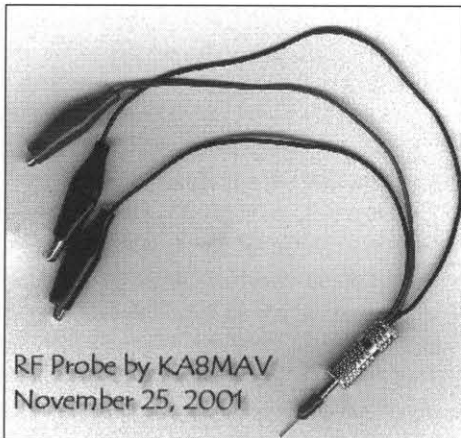

Figure 10—Overall view of the RF probe. Not clear in this B&W photo, there is one red (+) lead and two black ones (-). One black goes to the meter and the other to ground of the circuit under test.

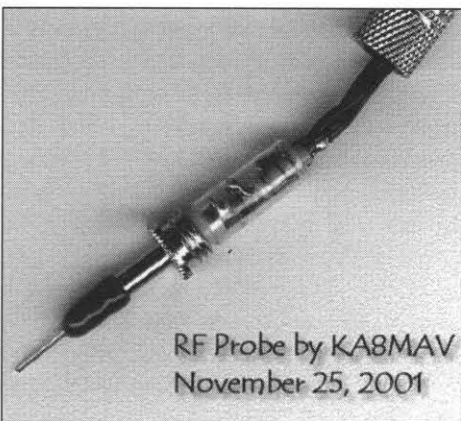

Figure 12—Inside view of the probe. The "boot" over the junction between the end of the plug and the probe tip is the "red covering" he mentions.

on. The red covering is a rubber toggle switch cover from Radio Shack with a pinhole poked into the end of it. Once the header pin was soldered onto the end of the phone jack, I simply slid the red cover over the end.

Figure 12—Here's a photo of the inside of the RF Probe. Notice the clear rubber tube covering the components? This is a shielded 1/8" phone plug from Radio Shack. Not only are they GREAT for RF Probes, but they make pretty decent connectors for keys too!

Figure 13—A closer look at the insides. I used the bodies of the components themselves to insulate them from the surrounding metal (ground). Yes, that's a 1/2 watt resistor crammed in there. I also

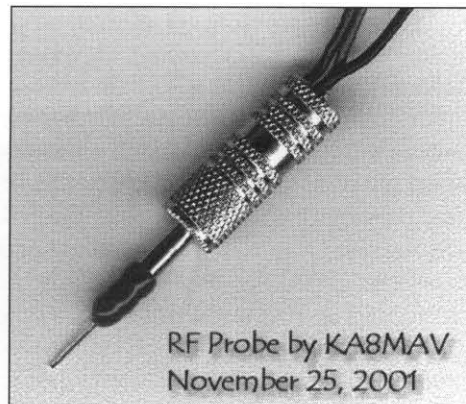

Figure 11—Close-up view of probe.

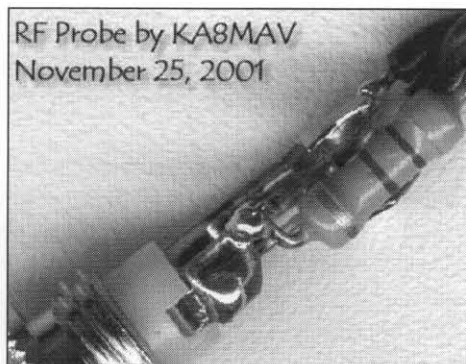

Figure 13—Close-up of the components.

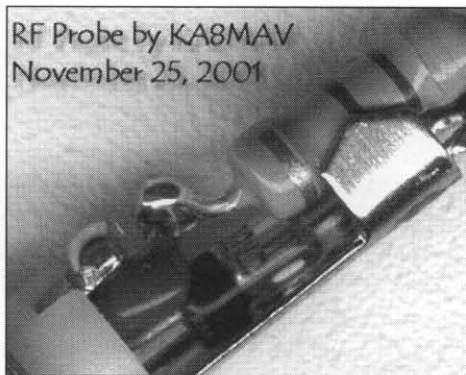

Figure 14—Another close-up of the components. The diode is more visible in this photo than the last.

used a little file to clean up the solder joints a bit as they had some sharp points on them.

Figure 14—Here is a much closer look. This shows how I used the bodies of the parts as insulators. Also, be VERY careful bending the leads this tightly. That's the second diode I used, as the first one shattered. They really are glass! Little glass shards everywhere. Be careful.

Check your work with a magnifying

glass to make sure there aren't any solder bridges.

If you want to see the full color pictures, you can find them at http://www.qrppi.com/KA8MAV_RF_Probe.htm

— de KA8MAV
(bdh@cyberbound.net)

Intermittent Alligator Clip Leads

When I first saw his web site and noticed that he used alligator clip leads, I made a quick comment and he added the note to be sure they are soldered. I told him that while these leads are sold everywhere, they are frequently not soldered (which makes them cheaper to produce). Many of the ones I've seen in the last 15 years have the alligators simply crimped onto the wires, resulting in connections that can eventually go bad and give problems.

Whenever I get a new set, either at home or work, the first thing I do is remove the plastic boot and inspect them to see if they are crimped or soldered, and repair as necessary. (Brice noted that removing the boot is much simpler if you first insert a screwdriver into the jaw and force it open all the way.) By the way, although I use the term "crimp" it's usually just a pair of small tabs folded over the wire.

To solder, I just jam the tip of the iron onto the point of the crimp and feed in a lot of solder. I don't worry about melting the insulation a bit since the boot will be slipped back on later and cover it up.

He told me that the ones he had from Radio Shack were soldered but you can't always count on that if you get them elsewhere. A few minutes spent checking, and perhaps soldering, will save some grief in the future.

— de WA8MCQ

Soldering Fume Hazards, Lead Safety

Here's some discussion on the subject from QRP-L:

From Stan McIntosh, KD4BTH (mcintosh@triad.rr.com)— "The subject of lead in solder fumes seems to be a 'QRP-L evergreen,' much like the QRP-ness of a directional antenna (factoring 'gain' into power calculations), harmonic noise of Ramsey transmitters, or whether no-coders should be allowed to continue to breathe the same air as the rest of us. So, please forgive me if I have already related this

story in a previous round of solder-related exchanges. However...

"A few years ago, at my former place of employment, we were looking at a non-traditional application for solder flux resin. In this application, there were going to be lots of hot surfaces, with a potential of 'flux' fumes. I contacted a consultant that specializes in solder-related issues. He said that the main hazard of flux fumes would be to people that have elevated tree allergies. Otherwise, according to a list of references he gave me, rosin fumes are innocuous.

"While I had the consultant on the phone, I also asked about traditional solder flux uses and related hazards. He quickly dismissed the idea of lead in fumes as urban legend, but cautioned that lead poisoning is still a risk. Lead is a very soft metal, and it can rub off with handling. Eating, drinking, and smoking during soldering should be prohibited, since they can all provide a means of transferring lead into the body through the mouth. Any person soldering should also be very careful to wash thoroughly before going on to another activity.

"After talking with him, I began to wash religiously as a wrap-up to tinkering at the bench. Even now, I won't leave the bench without heading straight for the lavatory."

A later post to QRP-L from Stan after receiving private comments--

"All I could relate was what the consultant told me, and what the documents that he provided supported. As someone with a severe asthmatic allergy to cotton dust, I can appreciate the problems with being sensitive to a series of compounds. As someone that has worked with some very potent sensitizers, and has had to read the accompanying literature, I will have to stick with my belief that solder flux is not a major sensitizer for most people. We were not made with a cookie cutter, so some people can be very sensitive to compounds that are quite harmless to the majority of the population.

"The bottom line is to use some sense, ventilation, and see a physician if symptoms start to appear.

"As for lead and plumbers, the poisoning would be from ingestion, rather than transdermal absorption. If someone solders and then fails to adequately wash before eating, smoking, nail biting, etc, then lead

can transfer through the process."

Someone later said that there is no lead in the smoke from soldering, just flux boiling off, and that lead requires a much higher temperature to evaporate. Leon Heller, G1HSM (leon_heller@hotmail.com), had this reply:

"You do get very small particles of lead in the fumes, even though it actually does not evaporate. As the flux evaporates in the molten solder it often sputters and will then carry the lead particles with it. It's the flux that can be quite nasty; some people get sensitized to it. I can't say it's ever bothered me much, though. I used to hold solder in my mouth, and strip thin tinned stranded wire in my teeth."

[WA8MCQ comment—Considering the possibility of lead ingestion, I would never hold solder in my mouth, as many people do. As for stripping wire with the teeth, that's between an individual and his dentist!]

From Brice Hornback, KA8MAV (bdh@cyberbound.net)— "Lead poisoning occurs when a person swallows or inhales lead in any form. The result can be damage to the brain, nerves, and many other parts of the body. Acute lead poisoning, which is relatively rare, occurs when a large amount of lead is taken into the body over a short period of time. Chronic lead poisoning, which is a common problem in children, occurs when small amounts of lead are taken in over a longer period.

"Lead poisoning can cause high blood pressure, digestive problems, nerve disorders, memory loss, and muscle and joint pain. In addition, it can lead to difficulties during pregnancy, as well as cause reproductive problems in both men and women.

"If blood levels of lead are high enough, the doctor may also prescribe chelation therapy. This refers to treatment with chemicals that bind to the lead and help the body pass it in urine at a faster rate. There are four chemical agents that may be used for this purpose, either alone or in combination. Edetate calcium disodium (EDTA calcium) and dimercaprol (BAL) are given through an intravenous line or in shots, while succimer (Chemet) and penicillamine (Cuprimine, Depen) are taken by mouth. (Although many doctors prescribe penicillamine for lead poisoning, this use of the drug has not been approved by the Food and Drug Administration.)

“For more information contact the National Lead Information Center at 1-800-LEAD-FYI (1-800-532-3394). Materials are available in Spanish and English.”

Noninductive Resistors Not Always for Dummy Loads

In a post to QRP-L, someone mentioned being in a Radio Shack store and seeing their 8 ohm, 20 watt noninductive resistor and wondered if it would be worthwhile to put six in parallel to come close to 50 ohms and make a good load with reasonable dissipation. A bit of discussion followed; there was some speculation, but no one actually did any tests, so I bought a few and did it myself.

Before I get into that, I'll present some commentary made by Steve Yates, AA5TB (aa5tb@arrl.net):

“Even with good non-inductive resistors it is usually better to parallel several high resistance resistors than it is to series connect several of low resistance. The inductance of every resistor will add together in the series configuration and will limit the useable upper frequency limit. The best approach that I have found (probably learned from the late Doug DeMaw, W1FB) is to parallel several resistors together by using some scrap double-side PC board as low impedance end connections.

“Simply drill holes where the leads will protrude and solder them to the copper. This minimizes the inductance. With very small resistors there may be too much capacitance between the end plates but with standard carbon resistors of a couple of watts or greater rating this isn't a problem because of the large spacing. I usually use four 2 watt, 200 ohm resistors in parallel. This gives me 50 ohms and easily handles 5 watts.

“The configuration of six 8 ohm resistors in series discussed by some may be fine for the lower part of the HF spectrum.”

Unfortunately, after doing some tests it turns out that the latter statement is overly optimistic.

The item in question is Radio Shack number 271-120 and it looks just like the other power resistors they sell. The front of the package says “Non-inductive for audio applications,” and the rear says, “non-inductive from 0-20 kHz.” Since they cost

about a dollar and a half each, I only bought 3 of them, which would give 24 ohms and allow me to get some useful data. Six would be 48 ohms and, if truly noninductive, would give an SWR of about 1.04:1 regardless of frequency. Using only 3 should give a constant SWR of 2.08, and cost half as much. It isn't important if my tests show an SWR number of 1.04 or 2.08; what is important is to see if the number remains relatively constant with increasing frequency, or if it goes up significantly. If it does shoot for the sky, it would make a poor dummy load.

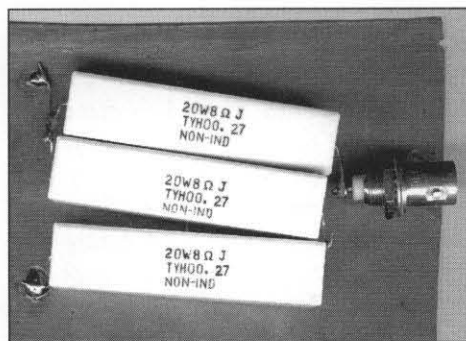

Figure 15—Three 8 ohm “noninductive” resistors in series to ground for the initial network analyzer evaluation. (When this photo was made, the left end of the top resistor was soldered to ground to test a single resistor by itself.)

I wired them in series on a piece of scrap circuit board with a BNC socket on it (Figure 15) and took it to work to check it out with an HP 8753D vector/scalar network analyzer. At one time you could say “network analyzer” and everyone knew what it meant, but with the explosive growth in computer networking that's no longer true. Now you have to specify “RF network analyzer.” The basic concept is that it applies a signal, sweeping across a frequency range that you specify, to a component or device under test, examines it with a receiver sweeping along in frequency in step with the generator, and gives a graphic display of the signal level coming out of the device versus frequency.

Something that does this is called a scalar network analyzer; it just gives the amplitude of the signal. You could do the same thing with a spectrum analyzer with built-in or external tracking generator, or even do it manually by sweeping a VFO across a frequency range and recording the output at various frequencies with an RF

probe. All accomplish roughly the same thing but with different degrees of sophistication, ease of use, accuracy and cost.

But all we have at this point is the amplitude of the signal. While that's very useful, with some additional circuitry we can also get phase information on the output signal with respect to the input. This drives up the complexity and cost, as well as the usefulness of the equipment. Together with some sophisticated computer processing, it becomes extremely useful. It's now called a vector network analyzer and can easily run into a few tens of thousands of dollars as does the HP 8753D.

To evaluate a single component rather than a network of components, the signal is applied and the reflected signal is measured. By analyzing the phase of the reflected signal with respect to the forward, you can tell if the device under test looks like a pure resistance at any given frequency, or whether it contains some reactance. In fact, it can also tell whether the net effect is inductive or capacitance reactance, give the value in ohms, and even calculate how much inductance or capacitance that equals at a given frequency. It's a really neat device.

I programmed the 8753D to sweep from the lower limit of 30 kHz up to an arbitrary frequency of 100 MHz. It will go up to 3 GHz, or 6 GHz with the doubler turned on, but limiting it to 100 MHz allows for better resolution, and quite frankly I expected the resistors to poop out well below that frequency. And they did. It gave a fairly good SWR of 2.15:1 at 1 MHz; remember, a purely resistive 24 ohms would give an SWR of 2.08. However, it ramped up pretty steeply above that, hitting 4.7 at 28 MHz, 9.4 at 50, and 23 at 100 MHz. Remember, those numbers are for something that, if perfect, would still give an SWR of about 2 across the board. Details are given in Figure 16.

With the push of a few buttons, the 8753D can alternate between SWR and Smith chart displays, as well as giving numerical readouts of the specs at selected frequencies. The impedance information shown here is in the familiar $R \pm jX$ format, where R is the resistive portion and jX is the reactive part. The sign on jX indicates what type it is; positive is inductive, and negative is capacitive.

This first set of readings was taken with the resistors in the side by side physi-

MHz	SWR	R	X
0.03	2.15	23.19	+j0.08
1	2.15	23.37	+j2.02
7	2.5	23.69	+j14.98
10	---	23.89	+j 20.0
14	2.8	24.25	+j 28.1
21	3.6	25.18	+j 42.5
28	4.7	26.58	+j 57.7
50	9.4	35.2	+j 114
75	16.5	63.9	+j 215
100	23.0	187	+j 425

Figure 16—Results from one set of tests on three resistors in series, nominally 24 ohms. If a perfect, noninductive resistance, the SWR would stay around 2.1:1 at all frequencies. Since the sign of X is positive, it means that it is inductive reactance. Although it varies with frequency, the net indicated inductance is around 318 nH over the HF range.

cal configuration shown in the photo, suspended above the ground plane of the board by a few cotton swabs. I ran another set of numbers with them spaced well away, to reduce the distributed capacity affects, and the next day I ran several tests with them spaced apart from each other and from ground in various ways. There were noticeable differences in the figures, but all results were equally horrible, dashing any hopes that a different physical layout might help make this a suitable load.

Before wiring the resistors I examined one of them under the industrial X-ray machine at work. It was obvious that there were two windings, but it was hard to tell if they were wound together or in opposite directions from each other. One thing that

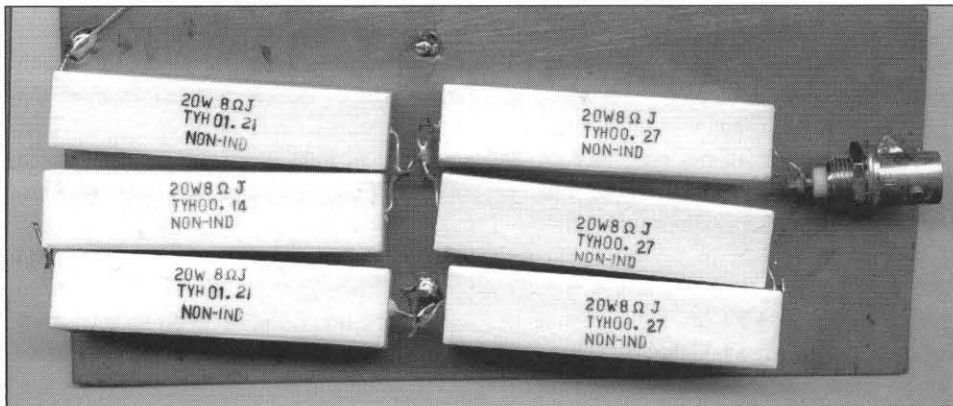

Figure 18—Six of the resistors in series now, and getting to be an expensive test! We're up to a little over \$9 at this point, plus another buck and a half for the one shown in Figure 17. If perfect resistors, this 48 ohms would give a fairly constant SWR of 1.04:1. It isn't and doesn't.

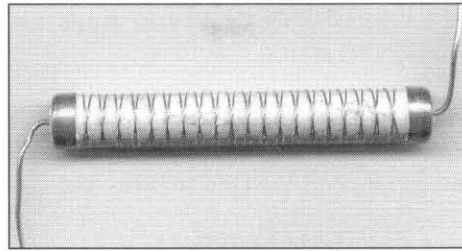

Figure 17—The “noninductive” resistor with the body broken away. Note that there are two windings of bare resistance wire, wound in opposite directions.

was obvious was that it was not a technique I had read about in which wire is wound in one direction along half the length then in the opposite direction the rest of the way to make the magnetic fields cancel out.

I later cracked off the rectangular body of one resistor to see how it was wound. There is a long ceramic bobbin with two windings, as shown in Figure 17. They are wound in opposite directions, crossing over each other at regular intervals along the entire length. Since the wire is bare, they are shorted to each other at the crossing points.

I didn't want to bother trying to extrapolate the figures to get something that would correlate directly to six resistors in series. Although it was starting to get a bit expensive, I bought 4 more the next day—three more for testing along with a replacement for the one broken open. While that one was still perfectly good, its physical characteristics had changed and was no longer identical to the others. For instance, the capacitance to ground would probably be different.

After doing several more test runs with the original 3 resistors in various physical configurations I wired the additional 3 in series as shown in Figure 18. I measured the DC resistance with 4 different Fluke meters, and three of them agreed on 47.1 ohms. As with three resistors, I found that I got noticeably different results depending on the physical configuration, which varied mutual coupling and capacitance to ground. But even the “best,” with them strung out in free space as much as possible, was quite horrible as far as an HF dummy load is concerned.

The results shown in Figure 19 were obtained with them aligned as shown in Figure 18, spaced above ground a bit. By the time I got around to adding the 3 new resistors I was getting quite sick of repeatedly pushing buttons all over the panel of the analyzer, so I cut it off at 50 MHz. The trend was clear, and additional numbers would only be good for shock value! Remember, the circuit is now approximating a 50 ohm load instead of 25, so no interpretation or conversion of numbers is needed.

While these resistors are readily available and perfectly fine for their intended application, which is clearly indicated as audio use, they should not be considered for use as an RF dummy load. For the same price of about nine dollars plus tax there are many alternatives which would produce a much better load, at least at QRP power levels.

— de WA8MCQ

MHz	SWR	R	X
0.03	1.07	46.5	+j0.15
1	1.13	46.7	+j5.1
3.5	1.44	47.1	+j17.7
7	2.04	47.8	+j 35.5
10	2.7	48.8	+j 51
14	3.8	51.0	+j 72.8
20	6.0	55.8	+j 107
24	7.8	61.1	+j 134
28	9.9	68.7	+j 164
30	10.9	74.1	+j 181
40	16	---	---
50	13.6	---	---

Figure 19—With six of the resistors, for a nominal 48 ohms, the SWR should be about 1.04. At 30 kHz it's about right (the actual resistance is 47.1) but it doesn't make a very good load much above 1 MHz.

QRP Online

As I say every issue, there's been a huge amount of QRP info flying around the Internet for years, and it's still there!

QRP-L, which I call the "QRP Daily," is the online QRP discussion forum started in 1993 by QRP Hall of Fame member Chuck Adams, K7QO (K5FO at the time). It continues to run several dozen postings per day on a variety of topics related to QRP.

QRP-F is an alternative QRP forum started by the QRP ARCI in October 1999 to take some of the load off QRP-L.

The forum, QRP-F, requires a web browser such as Internet Explorer or Netscape, while QRP-L is a mail reflector and only requires an e-mail account. (If you go to the QRP-L home page, you can check out all the archived messages back to Day One.)

To check out the online QRP world, go to these URLs:

QRP-L – Go to <http://qrp.lehigh.edu/lists/qrp-l/> and you're at the home page where you can sign up, read the archives, etc.

QRP-F – Go to <http://www.qrparci.org/> and click to enter the site, then click on QRP-F on the menu at the top.

And while you're on those home pages, don't forget to check out their lists of QRP related links; and at each link that you go to, check THEIR lists as well, since not all sites list all others. In addition to the QRP ARCI site, another excellent place to use as a jumping-off point for checking out QRP related sites is the NorCal home page, run by Jerry Parker WA6OWR, at <http://www.fix.net/~jparker/norcal.html>.

You'll find quite a wealth of QRP info online.

The Fine Print

The usual rules apply—just get your technical tidbits to me any way you can, online or US mail, handwritten or on disk, and hand drawn schematics and graphics are perfectly fine; I usually redraw everything on the computer. N2CX always sends along his own computer drawings, but you don't have to! Don't worry if you're not a professional writer or artist; I do all the editing and drafting, and all you need to do is get the rough info to me. ●●

Send your QRP ideas,
big or small, to Mike at:
wa8mcq@erols.com

Ramblings of a Peaux Displaced Cajun Lad in Maine

Joel Denison—KE1LA

hamjoel@juno.com

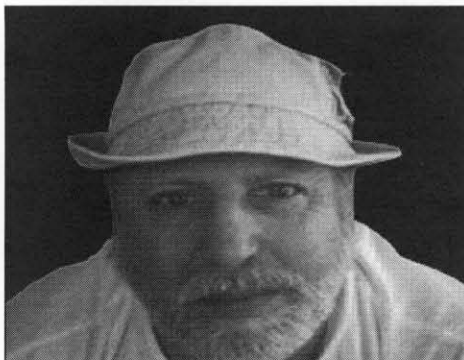

Hi y'all, how did u do it in SS this year? HI listened a while... sounded like lots of folk was havin' lots of fun. Kinda stirs my remembrance of Claudette—She married Alphonse, u kneaux....

Anyhow me and Claudette was going out at the time and between crawfishin', gatorin', fishin', huntin', Claudette, and hammin' ...sumthin' had to geaux... Too many things to do and not enough time to do 'm... Course now, Claudette got into my hammin' time—she would log, check for dupes, clean the shack and rub my back when ah was sending code for long times...

Then too, she would clean fish, skin gators, sort crawdads, and meaux de grass so ah culd ham and save my energies for her later in the moonlight, less of course, the skip and DX was good that

nite... then she would spot and log for me... what a gal!

One nite she come in the shack and grabbed my headset and made an announcement... seems ah had a decision to make... hammin' or her. Suprised, ah stopped my code and stood up and grabber her by her arms and asked.... "can't this wait till after the contest?" But she would not hear anything ah said... finally she turned and said... "Look FuFu.... Alphonse likes me and wants to spend lots of time with me while u just fish, hunt, and play radio!"

Hmmmm—this was serious... ah was losing contacts and this argument could geaux on for hours... so ah took time to think... U kneaux I like Alphonse and it sure seemed like ah would be doing Alphonse a favor if he had this little woman at his side... and that would free up time for me to do meaux hammin'...

"Claudette," I said... "I loves ya woman... but thair are sum things a fella can't do without... Ah wish u and Alphonse the best of everything.... U been a good girl friend... gotta geaux now... my QSO count is dropping..."

Without a word Claudette lowered her head and turned and walked outta the shack... so ah went back to contesting... However, in a few minutes this bucket of

SALT WATER comes gushing outta this pail and onto my radio... WOW!! Rice Krispies ain't got nuttin on the snap, crackle and pop ah heard that night! Sparks and flashes what would make a lightnin' bug feel inferior... Three moccassins jumped frum behind the xmitter finals and headed for safer territory... Meanwhile ah had jumped outta a window and could hear them hot tubes snap crackle and pop...

All this time Claudette stood by the door and just smiled... Then she threw the bucket at me and walked off... ah was heartbroke... my station gone up like a rocket... sure made me sad...

Then my Cajun Mama come outside and pulled me aside... she said, "look heah FuFu, iffing u gonna date a woman, the woman comes first... u dummy... got ur priorities straight, young fella!" Then she fell down laughing and crawled back into the house...still on her knees, in tears, laughin'. My Cajun Paw came out and looked at me, then at the radio shack and the now ruined radio... "Well son, U got u self off easy this time... be careful with them women, u hear?" And then just like mama he got to laughin'... heck between the two of them rolling outta bed and laughin' all nite it was hard to got myself to sleep...

Always check ur priorities... ●●

Test Topics and More...#10

Joe Everhart—N2CX

n2cx@arrl.org

Wow, the Microvolt Signal Source is finally done! Designed for Test will describe performance of the final project and discuss some late minute lessons learned. It's been a long time coming and, quite honestly, I'm glad that it has been finished. The pleasant results are as expected. A couple of construction details are described that are useful for other homebrewing projects as well as the MSS.

Coming to Terms

A very powerful testing technique called the substitution method is presented. Several examples are shown to describe its usefulness. This method is so basic to test and measurement in general that it should be part of any homebrewer's bag of tricks.

Stimulus and Response must once again be sacrificed due to space limitations. It is expected to resume with the next issue tackling the question "What is the best way to measure SWR?"

Designed For Test

The Microvolt Signal Source first begun in TTAM No. 5 back in October 2000 has now finished its construction and checkout! Admittedly I am a little prejudiced but it did turn out quite well. Photo 1 is an internal view with the top cover removed. Note that several of the top cover nuts have fallen off! The compartment cover internal nuts have two corners to hold them in place, but the top cover nuts are very weak since they are soldered on only one face. This is a shortcoming of the construction method used that needs refinement. Photo 2 shows an external view of it with all the covers installed. Other photos and diagrams throughout the year have shown it in various stages so they won't take up valuable space here.

Before we get to final test results here are a couple of tips gleaned during its construction.

As mentioned in TTAM No. 9 the compartment cover mounting screws were not recessed so that the covers would fit flush. As it turns out this did not seriously degrade shielding. Accurately cutting the internal compartment covers became very difficult. While I had meant to build all compartments to exactly the same size, my

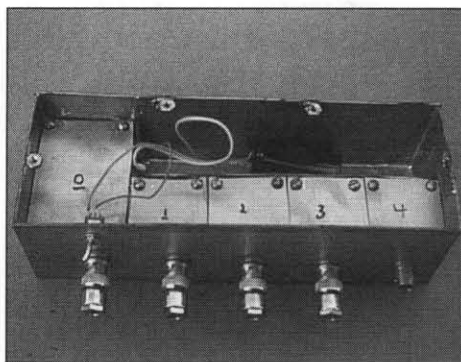

Photo 1. Internal view.

limited craftsmanship scuttled that idea. Instead each cover was cut to fit individual compartments. And since mechanical strength was not important, the covers were made from 0.02" thick double-sided pc board stock. The ordinary 1/16-inch thick material is fine, but I found that the thinner stock could be cut and trimmed with a good pair of household scissors.

Also as a result of the construction variation each compartment cover had to have its mounting hole screws located individually. The method for doing this was as follows. First, a thin piece of acetate sheet was cut into pieces to match each compartment. Then the sheets were placed one at a time where the compartment covers would go—after the mounting nuts were soldered in place, of course. Then, holding them exactly centered, a black indelible marker was used to place a dot lined up with the center of each mounting nut. Finally, the acetate rectangles were temporarily taped to the cover pieces and clearance holes drilled where the nut holes were marked.

The next improvement is not mandatory, but it makes life easier. An earlier column (TTAM No. 8, July 2001) described one method of constructing a well-shielded precision 50-ohm termination. It consisted of a 49.9 ohm, 1% resistor soldered inside a BNC male connector. The ground end of the resistor was soldered to a hole in a round scrap of p.c. board stock that was then soldered over the end to provide shielding. Several of these were made and they do work, although one potential handicap was not mentioned. With ordinary BNC connectors there is a tendency for the

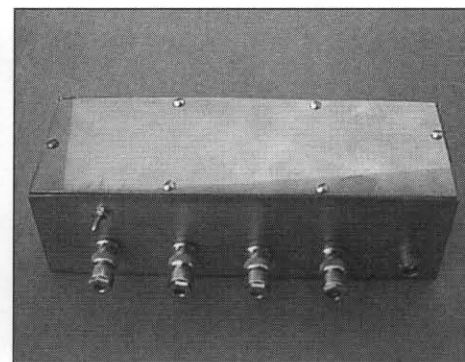

Photo 2. View with covers installed.

center pin to be pushed back into the connector body with repeated use. Eventually this gives an intermittent connection. One solution is the rather messy process of securing the resistor inside the body with epoxy. This works OK, but complicates construction.

I was fortunate enough in my scrounging to come up with some Bendix 39100-2 connectors. These have a one-piece inner body that mates the center pin through an insulator to a grounded flange that is firmly in place by a threaded back piece. The latter normally holds coax cable braid in place but serves in this case to hold the whole thing together. On the left side of Photo 3 you can see these pieces along with a 1/4 watt 49.9 ohm, 1% resistor.

To the right side are first another inner body with a resistor soldered in place, and finally the completed inner body. On the latter, the open end is completely shielded by a scrap of copper foil soldered in place. This copper foil by the way is very handy

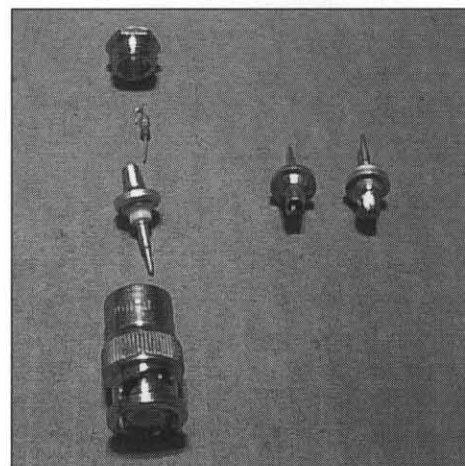

Photo 3. Bendix connector assembly.

for homebrewing. It is available from craft shops that sell supplies for leaded glass crafters. Available in various widths (I like 1/4 inch), it is backed by a high temperature adhesive and a \$5.00 roll will last for years! And while you are in the craft shop check out the 50-watt soldering irons. They are great for soldering p.c. board boxes together.

Now for the wrap-up on MSS performance.

The main idea was to develop a stable RF source with various output levels from 100 mV down to 1 uV.

The internal signal source is a crystal oscillator with a low-noise output at 7.04 MHz although the same design should work on any spot frequency over the HF range with an appropriate quartz crystal. The levels were to be settable and repeatable by home constructors without exotic parts or test equipment. The most sophisticated commercial instrument needed is a DMM. The only other test gear required is a simple diode detector that could be constructed from Radio Shack parts.

As they say, "the proof is in the pudding" so let's see how well the output levels were achieved. Testing was done using a calibrated HP 8568B spectrum analyzer after the signal source was calibrated with the simple test equipment outlined. Table I compares the original desired (spec) levels, the expected values based on the 1% components used, the measured values and dB difference between the desired and measured values. The measured operating frequency was 7.041 MHz.

The lowest output level is only approximate since the internal noise floor of the analyzer is only 5 dB or so below the level indicated.

The results are embarrassingly close. It was expected that the effects of resistor tolerance and possibly leakage between sections would cause a gradual degradation of accuracy at the lower levels. To quote another old chestnut, "Your mileage may vary."

A non-qualitative test was done to verify leakage due to imperfect shielding. The 1 uV output was connected to a Sierra transceiver to verify that the receiver was set to oscillator frequency. A satisfyingly weak signal was observed at 7041. Then a one foot test lead was run around the exterior of the MSS case to check for leakage. With the top over removed, a very faint signal could be heard in the Sierra. With the top cover in place there was no evidence.

A second test was to run a two foot length of coax from the Sierra input to the MSS case and sniff around the case (with the top cover in place). With the coax shield grounded and the center conductor held near the MSS case, only a very faint signal could be observed with the lead near the oscillator end. However when the center conductor was shorted to the case near the oscillator end, leakage that seemed to be about the 1 uV level could be heard. With both the shield and center conductor at the 1 uV connector end, nothing was observed, and the level did increase the closer the center conductor was connected to the oscillator end.

Finally, magnetic field leakage was checked with a two-inch diameter loop at the test end of the two-foot coax cable. With the MSS cover off, leakage was observed, particularly with the loop in some orientations near the oscillator end. The observed level was probably 3 to 6 dB above the 1 uV level. With the cover in place, the leakage was observed only with the test loop near the oscillator end and it was below the 1 uV level.

In short, the shielding is doing its job quite well. So long as coax cable is used for connection to one output of the MSS at a time, output level accuracy should be unaffected by leakage. If long test leads are used, they should be positioned away from the oscillator end of the MSS in order to preserve calibration.

Overall it exceeds expectations. However far more effort was necessary to

bring it to completion than was anticipated. There were a number of design and implementation changes along the way that have been described in this column and in several Joe's Quickies. But there is not enough space to document all of the final details in this column. However a more comprehensive set of drawings, photos and descriptions are being made available at the NJQRP web site. To see the latest info go to the web site at www.njqrp.org and click on the link to "Projects" and then to "Microvolt Signal Source." There should be sufficient detail there for interested parties to duplicate the MSS. However it is not a project to be undertaken lightly.

A number of folks have expressed a desire to have a kit make for the MSS. Whether or not such a kit will be made available is being examined. There is a fair amount of precision work needed to cut the various enclosure parts to precise dimensions and quite a bit of skill and experience is required to do the construction. In its present form it is definitely a project suited for the advanced homebrewer. Other enclosure options are being pursued that can be built by those with lesser experience and time. If a simpler solution can be found, the kit may appear as an NJQRP project. If not, it is still something that master homebrewers may want to tackle. However aside from the case most other components are readily available through familiar mail order sources.

Coming To Terms

Substitution—A powerful technique used in testing is the so-called "substitution" method. In it, several tests are done on a given circuit or device, one set of tests in the "normal" configuration and another with part of the original components replaced by others and another set of measurements made. The idea is that the substituted parts have similar properties to the ones replaced, but are easier to measure.

One example of this was described in Wes Hayward's landmark article on crystal lattice filters. In the article he characterizes individual quartz crystals using simple test setups. To measure the series resonance of a crystal, he feeds an RF signal through the crystal and monitors the amount of RF that passes through it. A simplified setup is shown in Figure 1.

At the crystal's series resonance, its effective series inductance and capacitance

Spec.Level	Calculated Level	Measured Level	dB Difference
100 mV	100 mV	100 mV	Set level
20 mV	20.0 mV	20.4 mV	+2 dB
1 mV	1.05 mV	1.02 mV	+2 dB
50 uV	54.8 uV	51.8 uV	+3 dB
1 uV	1.14 uV	1.06 uV*	+5 dB

Table I. Microvolt Signal Source Test Levels.

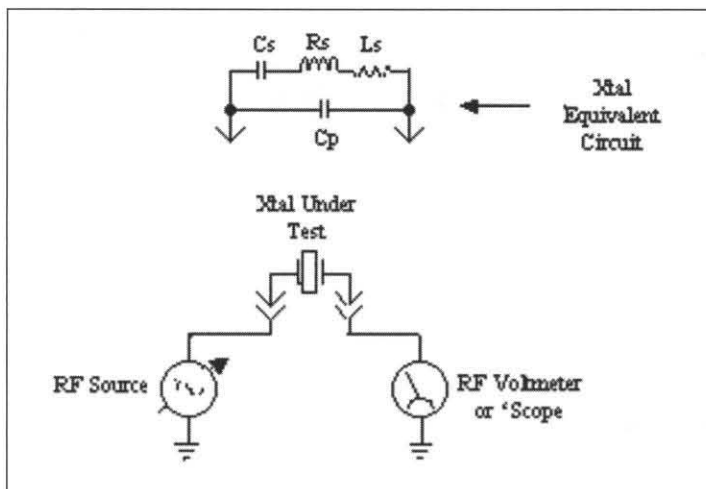

Figure 1. Simplified crystal test system.

(L_s and C_s) have equal reactance so their effects cancel leaving only the effective series resistance. The output level is then noted. Now without changing any settings the crystal is replaced by a potentiometer connected rheostat style as in

Figure 2: The pot is then adjusted to give the same output level reading as with the crystal plugged in. Finally the potentiometer is removed from the test fixture and its resistance is measured using a DC ohmmeter. Neglecting stray capacitance and inductance of the pot leads, the DC resistance value is equal to the crystal's series resistance.

The beauty of the whole procedure is that the crystal's series resistance value is measurable without any fancy test equipment. Commercial test sets to do the same measurement cost many \$k. Of course they are more precise, but that's overkill for homebrew crystal filter design.

An example of a related type of test is one used to measure the loss of some types

of baluns. 1:1 baluns are simple. As shown in Figure 3, you connect the balun between signal generator or low-power transmitter and dummy load. To measure insertion loss you measure the input power from the source and compare it to what's delivered to the load. That's fine, but how do you do it with, for example, a 4:1 balun? Many of us have 50-ohm power meters and 50 ohm dummy loads, but not gear intended for 200 ohms!

The answer is to use two identical baluns connected back to back. Figure 4 illustrates this. The desired 50 ohm impedance is preserved at both ends so common test equipment is does the job. The insertion loss of each balun is simply half the total. Actually the same method works for any pair of baluns so long they are identical and one side of each matches 50 ohms.

There are numerous other ways that the substitution method can be used. More will probably be discussed in future columns to

show how we homebrewers can use smarts instead of dollars to use simple gear for sophisticated measurements.

Of course the substitution method depends on the assumption that the substituted components respond linearly and that definitely is a topic for the future.

Stimulus and Response

While I do have a topic for next time many of the best topics for this section of the column and for the others as well come from queries from others. So please send in some feedback about what you would like to see in the future or what past topic you'd like to learn more about. You can send e-mail or snail mail to my addresses below or see me in person. I'm always glad to answer whatever questions you may have.

Reference

1. Wes Hayward, W7ZOI, "Unified Approach To The Design Of Crystal Ladder Filters," *QST*, May 1982 page 21. ●●

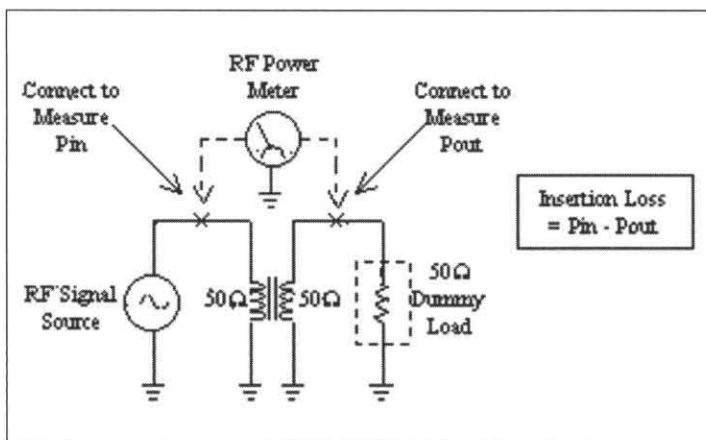

Figure 3. 1:1 balun insertion loss measurement.

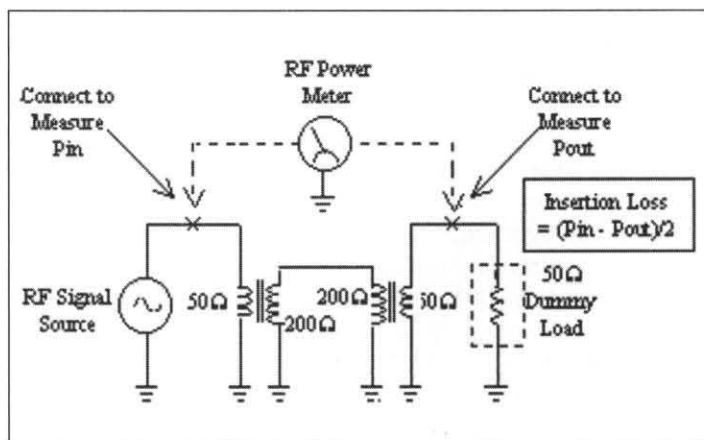

Figure 4. 4:1 balun insertion loss measurement.

The KFL1-4 Four-Band Module for the Elecraft K1 Transceiver—A Builder's Review

T. J. "Skip" Arey—N2EI

tjarey@home.com

If you are like most Elecraft transceiver users, you hang out on or at least periodically check the Elecraft E-mail List Server. A common practice on this list is for users to make suggestions and for the designers Eric Swartz, WA6HHQ, and Wayne Burdick, N6KR, to banter back and forth with us about wishes for the rigs and new features, accessories, etc. What often happens is list readers will get a sense that something is in the air and you can just see Wayne and Eric grinning into their monitors as the many users speculate on what the next neat thing to come out of Aptos, California will be.

That was the case in mid-October of last year. Word started to circulate that something really neat was going to be unveiled at Pacificon. Many of us loyal Elecraft K2 owners had just finished melting solder installing the new Audio Filter and Real Time Clock board. My personal "wish" has always been for Elecraft to someday announce a "K3" general coverage receiver. (I can dream can't I?) The team at Elecraft was really playing this one close to the vest. All was revealed on Friday October 19th. The KFL1-4 Four-Band Module for the K1 was released to its waiting public. Lisa Jones was swamped with orders that following Monday when she arrived for work. Of course, my order was in that first pile too.

The Elecraft K1, for those who are unfamiliar, came on to the QRP scene as a diminutive two-band CW transceiver designed with lightweight, portable operation in mind. With its many advanced features and excellent QRP performance, the rig developed a following to rival that of its big brother the Elecraft K2. I had been using my K1 for business trips, during lunch hour at work and on vacation. I had configured my version for 40 and 20 meters and had loads of fun. My only com-

plaint was that on big contest weekends it would be hard to find a nice quiet frequency to ragchew on. The KFL1-4 board solved this problem and made a great transceiver even better.

Eric and Wayne have figured out a way to squeeze two more bands into the K1's form factor without sacrificing any of its

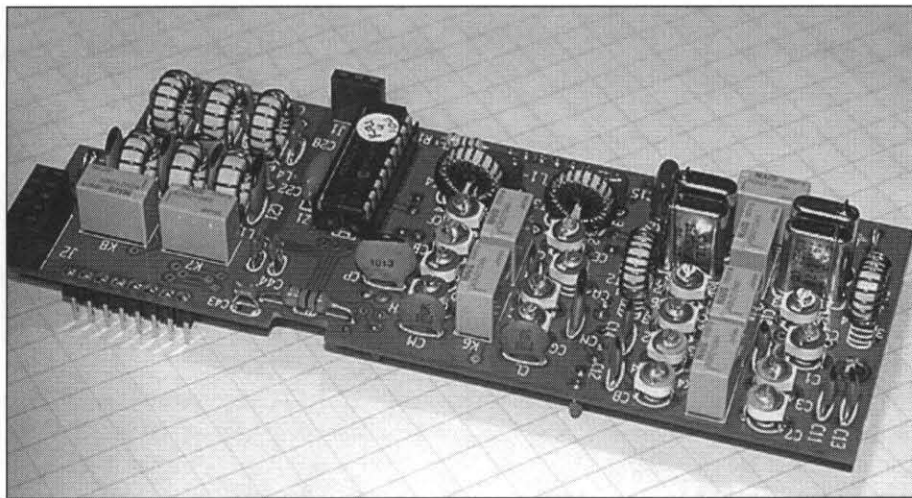

operability. The four-band module covers several of the most popular HF bands. 40 and 20 meters provide activity day and night, and are important for contests, Field Day, and QRP events. 30 meters has a small but active CW segment, and as a WARC band provides a "haven" from contests. The fourth band can be either 15 or 17 meters (the decision to be made at build-time). 15 meters is a traditional low-noise, daylight DX band, and is very active during Field Day. 17 meters is another contest-free zone, and stays open a bit longer than 15 meters. Most importantly, the change to four bands allows for use of all the option features that are available for the K1 including the Automatic Antenna Tuner, the Noise Blanker and the Internal Battery Pack. The four-band option for existing K1s (KFL1-4) is \$129. But if you have yet to experience the fun of portable operation or great kit building, the complete four-band K1 transceiver kit is priced at \$349.

My KFL1-4 board kit was received within two weeks of my order. Kit quality has been exceptional from the day Elecraft opened its doors. This new board was up to

this tradition. All parts were well packed and of the highest quality. The double-sided printed circuit board is solder-masked with plated through holes (see the accompanying photo). The construction manual exceeds the industry standard, the classic "Heathkit" manuals of bygone days. Prior to receiving my kit, I had downloaded a copy of the manual from the Elecraft web site (www.elecraft.com) so I had a good sense of what I was facing.

Let me back track a bit to the construction of my original two-band K1 for a moment. The K1 transceiver is designed around a Control Board, an RF Board that contains such essentials as the VFO and last but not least, the Filter Board. The Filter Board contains the LC circuits and crystals that make the rig work on the bands chosen by the user. The original two-band configuration allowed for a choice (at time of purchase) of any two of the following bands: 80, 40, 30, 20, 17 and 15 meters. As I mentioned earlier, I chose 40 and 20 meters. The most difficult part of building my original K1 came in the area of alignment. The 20 meter sections were very touchy compared to the 40 meter band and it took more than a few trips to the Elecraft listserv to get things going in the right direction. I was a little concerned that getting four bands tweaked just right would be even more difficult, especially since the band sections in this new design "borrow" capacitance from one another to get all bands to resonate. As it turned out, I had nothing to fear.

The KFL1-4 kit went together in two leisurely evenings. As with all Elecraft kits, if you follow the directions in the manual explicitly you will not have any surprises. The user has to make only one major decision during the build, that being choosing either the 15 or the 17-meter

band. Crystals are provided for either path. (I chose 15 as I find it a bit more productive than 17 given my operating habits.) The closest thing to difficulty I found was those steps that required adding parts to the bottom of the board, requiring soldering on the top of the board near previously installed components. Care needs to be taken to keep your soldering iron in a position that does no harm. But with such care, a standard body "Weller" style soldering pencil with a fine tip fits in without trouble. Some people have difficulty working with toroids (ten in this kit) but this has never been a problem for me. With this board design, you do have to be careful to observe the direction of the windings to assure proper hole alignment and functionality. Again, following the manual to the letter will keep you on the right course.

Experienced Elecrafters will discover that the relays supplied with this board are somewhat smaller than those in previous Elecraft kits. These new relays have the added advantage of having pin positioning that prevents installing them in the wrong direction.

The manual takes into account all the various permutations of accessories that a user might have installed in a previously built K1. The builder is instructed as to

what to remove, reposition and when. Here some folks may run into a bit of trouble. If you have the KAT1 ATU option, you must temporarily re-solder R36 on the back corner of the RF board. This is in particularly cramped quarters. Extra caution needs to be taken to avoid melting the casing of J8. When I have a bit of time I plan to look into the possibility of connecting R36 from the bottom of the RF board as I only need to use it for alignment purposes.

Speaking of alignment, it was a breeze. I actually found it much less troublesome than the original two-band board. In my case, the audio peaks were high enough that I could essentially tune the rig by ear on the receiver alignment steps. Transmitter alignment benefits from an analog Wattmeter but can be accomplished with the K1's own power meter as well. The "smoke test" went without a hitch. The existing firmware on the K1's Control board and on the KAT1 ATU recognized the four-band module without any questions or concerns. Actually, this is not too surprising as they would likely encounter two-band board combinations of all the bands the new Filter Board presents.

Perhaps the nicest compliment I could pay this design is that the new four-band version of my K1 works as well on the air

as the previous two-band incarnation. When I get to playing with my K1, my K2 starts to collect dust. It's just a fun radio, period! I've previously written in several forums of how pleasant I find the audio and signal filtering on the K1. The KFL1-4 has proven itself on all four bands. The versatility of two additional bands is a vast improvement that I expect will make those off-hours on business trips that much more enjoyable. When I use the rig on my lunch break at work, having 15M as well as 20M gives me a bigger chance to come up with a few casual QSO's in the limited time I have available. I'm also finding 30M a respite from the creeping SSB signals on 40 in the evenings. I know some folks will wish the design accommodated 80 meters but, for myself, I'm not all that productive on 80 and the portable use my rig gets does not really lend itself to antennas that would take real advantage of that band. Like many folks who take the four band option on their previously built K1's, I'll probably rebuild the two-band board for 80 and 17 just for the fun of it.

So Eric and Wayne have hit another one out of the park with the KFL1-4 board. Building this kit and operating my four-band K1 only leaves me with one question: Hey guys, what's next??!! ●●

2002 Spring QSO Party Announcement

Date/Time: April 13, 2002; 1200Z through April 14 2400Z. You may work a maximum of 24 hours of the 36 hour period. CW only.

Exchange: Members – RST, State/ Province/Country, ARCI Number; Non-member – RST, State/Province/Country, Power Output.

QSO Points: Member = 5 points; Non-member, Different Continent = 4 points; Non-member, Same Continent = 2 points.

Multipliers: SPC (State/Province/ Country) total for all bands. The same station may be worked on more than one band for QSO points and SPC credit.

Power Multiplier:

0 - 250 mW = x15

250 mW - 1 W = x10

1 W - 5 W = x7

Over 5 W = x1

Suggested Frequencies:

160 M 1810 kHz

80 M 3560 kHz

40 M 7040 kHz

20 M 14060 kHz

15 M 21060 kHz

10 M 28060 kHz

Teams: You may enter as a team of either 2 to 5 members per

team, or unlimited number of operators as long as a maximum of 5 transmitters on the air at a time. You compete individually as well as on the team. Teams need not be in the same location. Team captain must send list of members to Contest Manager before contest.

Score: Points (total for all bands) x SPCs (total for all bands) x Power Multiplier.

Entry may be All-band, Single-, High-, or Low-Band. Entry includes a copy of logs and summary sheet. Include legible name, call, address, and ARCI number, if any. Entry must be received within 30 days of contest date. Highest power used will determine the power multiplier.

The final decision on all matters concerning the contest rests with the contest manager. Entries are welcome via e-mail to rfoltz@turbonet.com or by mail to

Randy Foltz
809 Leith St.
Moscow, ID 83843

After the contest send your report by visiting: <http://personal.palouse.net/rfoltz/arciform.htm>. Check the web page at <http://personal.palouse.net/rfoltz/arcihighclm.htm> for 2 weeks after the contest to see what others have said and claimed as their scores. ●●

Laptops for the Field and the Hamshack

Preston Douglas—WJ2V

e-mail

Ever think about setting up a ham shack that could easily go on the road? Or, into the hills? Are you looking for a computer to carry into the field for Field Day logging? Or, for PSK-31, or RTTY, or SSTV while you travel? And if you really must work while on the road, these same machines can take care of your e-mail chores as well. Here's how you can do it all for about \$300 (especially if you already have the software), and give your back a break at the same time.

What to look for, and where to find, these wonderous machines

Before I can give you a parts list for this project, I'll have to explain about these machines. They are "sub-notebooks," which means they are much smaller and lighter than most laptops. They usually weigh less than four pounds, with battery, and have nine or ten inch screens. They can be unbelievably cheap too! The main thing is to find a reputable brand machine that won't die on you the first time it meets with a small accident.

Be sure to look for a machine that has an active matrix screen (the best kind). Otherwise, screen readability may suffer. Consider also the minimum size screen you need. It is possible to find machines such as a Libretto sub-notebook or a Sony C1X that weigh less than two pounds. However, long term use of these machines almost guarantees eyestrain. I prefer the Toshiba Portege line of small machines, and particularly the Portege models T610 and 300CT, which have Pentium 90 and Pentium 133 CPUs respectively. There is also a later version, the T3020CT. At about four pounds, these machines are much more usable. This article was written on a 300CT; I left my much faster Sony Picturebook C1X at home. The sharp, active matrix screen in the 300CT is about an inch larger than the screen on the T610, and more rectangular, making it more amenable to 1024/600 standard resolution. The screen on the 300CT is excellent. However, the screen on the T610 actually appears to be brighter and sharper. For comparison, the screen on the smallest Sony, the C1X and its successors, is about half the size of the T610. But, I find that

their screens are just too small for daily use.

Machines of this class are perfectly capable of doing the things most hams require, even if they are not "state of the art." The T610 comes with about 16 Mbytes of RAM, and is expandable to 48 Mbytes. The 300CT has 32 Mbytes of RAM, expandable to 64 Mbytes. The memories of both machines can be expanded by adding a card through a hatch. If you find a machine with extra memory already installed, that's all the better.

Consider also how easy it might be to change the hard drive (HDD), should you need more data storage. For instance, the HDD in the T610 is only accessible by opening the whole machine. I don't advise you to do that yourself (more on this point later), so you are essentially stuck with the 750 Mbyte sized drive. In addition to coming with a much larger HDD (1.6 Gbyte), the 300CT drive can be changed by opening an external hatch-without risking damage to the internal parts. (Another advantage of the 300CT is that it has a built-in 33.3 kb/sec. modem.) Alternatively, there are machines out there with larger drives already installed. Not surprisingly, machines with expanded memory and/or larger hard drives command somewhat higher prices

Don't forget that, in an effort to save weight, many of these machines have components that are not internal to the notebook. For example, Toshiba took the floppy drive out of its Portege series, as is typical of most machines of this type. The floppies are generally supplied as an external device, connected through a "dongle" cord to a special connector. You may also need a docking port of some kind, in order to mate these accessories to the notebook. The 300CT, for instance, needs a minimal docking station (or "port bar") to be useful. You will need its little port bar accessory to connect a floppy drive to the machine, as it does not have the connector on the body of the machine itself. Don't buy a 300CT without the port bar! There is also a 300CT multimedia docking port, which includes a CD ROM, all the usual legacy ports, small stereo speakers, and video

monitor connection, and is often seen for as little as \$50 on the used market. It will make for a very complete small system for shack and field. There is a docking port for the T610 as well, but it doesn't include a CD and it isn't essential. If you already have a Toshiba laptop, and you have an external floppy with the sub-mini "D" connector, it will probably work with these machines, and you will then be ready to go. Otherwise, factor in the cost of a Toshiba external floppy (about \$65 on auction). Another alternative might be an accessory that connects through a PCMCIA card interface. Again, the cost of this accessory must be figured into the total system price. Finally, consider spending a mite more for the later model Portege 3020CT. Try to buy the 3020 with its proper matching floppy drive, as this model requires a different connector than the older models' floppy drive. The 3020 has a Pentium 300 and comes with at least 64 megs of ram and a massive 6 Gig hard drive. This is an early "super thin" machine, and it weighs in under three pounds. The long life battery should give you over three hours on a charge, too.

To give you a notion of what these machines look like, Figure 1 is a picture of my T610 with the external CD-ROM used to install program files. Figure 2 shows a later model T3020, with its external floppy drive.

Next, you have to know where to buy these things. In a word—Ebay. Online auctions are like twenty meters. On twenty, you should do a lot of listening before you push the talk button (or grab the key). On Ebay, you should do a lot of watching before you start bidding. Once you've observed Ebay for a while, you'll learn how to minimize your risks. There is always a small risk when you buy something on Ebay, but that's where used computers go. I have looked at other online auctions, and frankly, size matters. The smaller auctions have fewer sellers, fewer buyers and less competition. Reserves are generally higher on these smaller sites. Just keep in mind that you are buying used goods and there won't be any guarantee. Figure to pay about \$125 for a bare T610; about \$200 for a T610 with the floppy

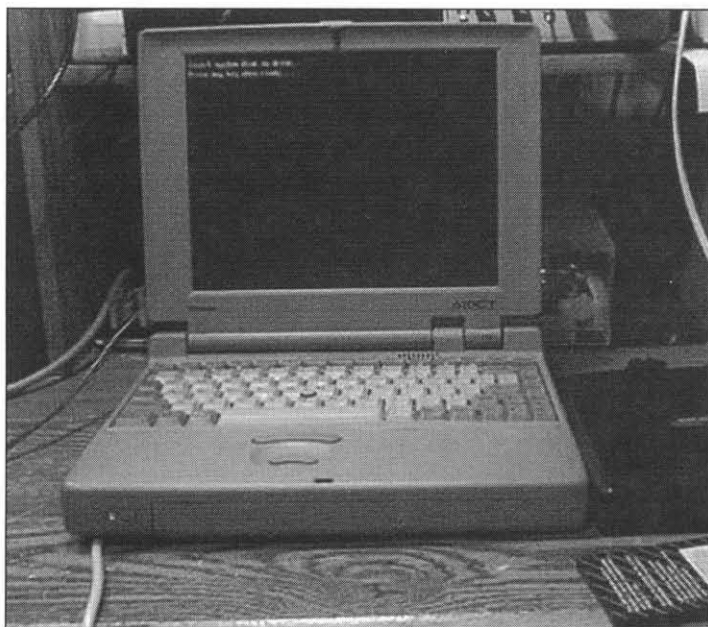

Figure 1. Toshiba Portege T610.

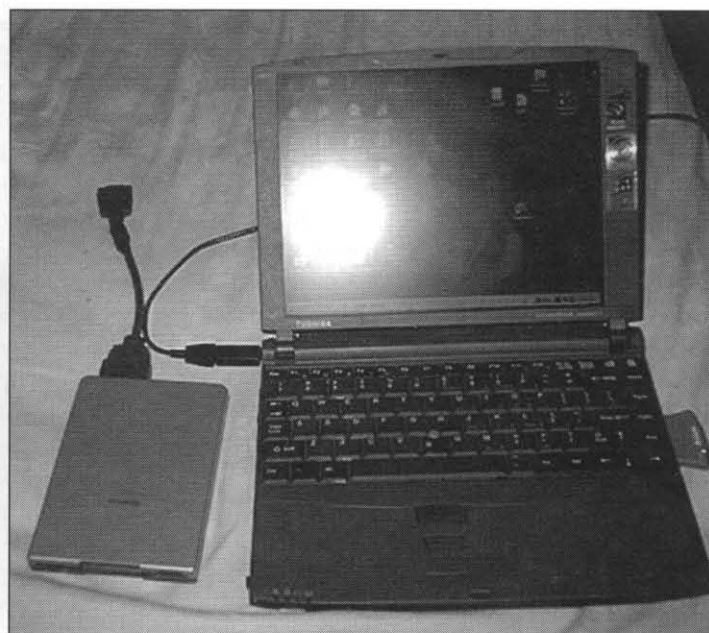

Figure 2. Toshiba T3020 with external floppy drive.

drive. 300CTs run about \$50 to \$75 more. Remember, if you buy a 300CT, make certain it comes with the little port bar that is essential to its operation. The 3020 CT sells consistently for around \$400, and it is worth the price, if it comes with the floppy disk drive.

Possible Problems

Some notes about the features of the Toshiba machines should be helpful, if you decide to look for one. Other machines in this category have similar problems. The weak points in the Toshiba laptop line are the screen/hinge system and the battery/charger system, again typical of most sub-notebooks. The screen connects to the base via a flexible flat cable that may fail. Daring technicians may wish to try to repair the connections, but opening these machines is chancy. The insides have several of these flexible cables, and they have almost no slack. They are plugged into fragile sockets that will break easily as you lift the keyboard to reach the innards, at which point you have essentially killed the machine. My record is one fixed and two killed. On the other hand, if you have a dead screen, you have little to lose. The folks at Toshiba will not sell repair manuals to the public, and their so-called support volunteers sneer at requests for assistance in repairing innards, preferring to provide long lists of repair facilities. Of course, it makes no sense to pay a repair firm a couple of hundred dollars to fix a

machine that is worth less than the repair bill. (New LCD screens can cost closer to a thousand dollars!) On the other hand, if you have a software problem, the Toshiba web site (www.Tohsiba.com) has a good collection of updates for these machines, including video, audio, utility, BIOS upgrades, drivers, and patches.

The other problem is the batteries and the internal charger. The Li-ion batteries can die in a shorted or open state, which will blow out your internal charger (which is interconnected with the internal power system) and this internal failure will keep the machine from booting. If you have a failing or failed battery, GET IT OUT OF THE MACHINE before it hurts the computer's internal power supply/charger. One way to identify a bad battery is with the optional external charger. Each of these machines has an optional external charger available, and it is a good investment. Get the correct one for your machine/battery. A bad battery will light a RED led on this charger, and that's your signal that you should not use it in your computer anymore. I have opened the battery cases. They are pretty sophisticated; there is a circuit board with an IC, and repairing the battery with new cells will not be easy. When I tried prying up the cells in one of these units, I shorted the circuit board, thus adding to my death toll. The cells appear to be oversize (fat) AA style, for those who would like to try a repair. On the other hand, I have found that opening the battery

case and force-charging it on my home-brew shack charger saved one "red" battery, at least temporarily.

Despite these flaws, most of my machines have been very reliable.

How to get this machine up and running

The other consideration is that these machines may well come without an operating system, i.e. Windows. Microsoft takes a dim view of copying their products, and many people remove the OS before they sell their machines. This is the major part of the project: installing an operating system. Keep in mind that the installation is made much more complex in a laptop because Windows does not have the drivers for the outboard CDs used with laptops. Yes, I know Win 98 SE has basic drivers for CD drives, but it probably does NOT have the ones you will need to get your external CD working—another reason to find an external floppy and its driver, meant for this machine. Once you have located a suitable machine, you will need to get Windows installed, along with your various application programs. There are two basic methods for installing Windows 98 into these machines. The first takes longer but is easier for some less sophisticated users. I have used both methods successfully. For the first method, you will need the following:

1. The basic computer, and if it is a 300CT it must have the port bar.

2. A compatible floppy drive (I borrow the one that came with another Toshiba I already had.) Almost all Toshibas (but not the 3020) use the same floppy connectors and recognition of the floppy drive is built into their BIOS.)

3. A PCMCIA outboard CD ROM drive with DOS drivers on floppy. EXP makes one that is \$169 retail, and they can be found at www.expnet.com. You can find these drives for less than \$100, for an older model. You don't really care if it's 8x or 20x drive with these machines. You may even be able to borrow a CD-ROM to get yourself up and running.

4. DOS on floppy. I use a three floppy disk set of v6.22, which works very well.

5. A full (not upgrade) version of Windows 95 or 98. On the 300CT, Win 98 SE is preferred because it will handle the USB port better. (Of the models discussed, the 610 CT does not have USB; the others do; also while all these machines have PCMCIA slots, the 300CT and 3020 have Cardbus capability associated with these slots, which is necessary if you plan to use the PCMCIA port for wireless networking—earlier PCMCIA slots don't have this capability, which I learned from bitter experience. My research has led me to believe that there are no wireless network PCMCIA cards made that do not require Cardbus technology.)

The "climb-the-ladder" clean installation goes like this:

- First, using the outboard floppy drive and the startup disk from your DOS set, format the hard drive.

- Then install DOS 6.22 (or similar late version of DOS) on your system. While this installation will be overwritten later by Windows, DOS is necessary because the driver installation disk from EXP (or other CD manufacturer) will look for some basic DOS files before it can set up the CD drivers.

- Once DOS is installed, plug the CD into the PCMCIA slot and run the DOS setup from the CD installation disk. You will be presented with a complicated looking screen that requires you to choose a memory segment and interrupt. Most of the time, the defaults will work. If you get errors on reboot, and the CD won't load, then reinstall with a different interrupt (usually either 11 or 14 will work.) Now,

your computer should be able to "see" the CD, usually as the "D:" drive.

- OK, now load your Win 95 or Win 98 CD into the CD ROM drive, and install the system. It should take you about an hour to get it all done on a little machine like these. (Well, they aren't that fast compared to the latest models, but who cares?) You will reach a point where a screen asks you if you are using a network or other device to load in Windows, and you should answer this question "NO," else you'll run into problems. The installation will restart your machine several times.

- Once Windows 98 SE is installed, and before you install more programs, it is a good idea to change your hard drive to FAT 32. The only disadvantage to starting the process using a DOS installation as we did here, is that the HDD will have been formatted in the older FAT 16 system. This simply means the subsystem used to do the hard drive housekeeping is using a less efficient system than the superior Win 98 FAT 32 subsystem. There is a utility in Win 98 to convert the drive. It is reached by clicking START/PROGRAMS/ACCESSORIES/SYSTEM TOOLS/DRIVE CONVERTER. The conversion process may take an hour or more, so don't try this on battery power. You will have a terrible mess if the computer shuts down in the middle of this process. Note, that the machine will work quite well without the conversion, but it will be a shade faster and will have a bit more room on the HDD after conversion. If, however, you are planning to use compression to double the HDD space, FAT 32 won't work. Compression will slow your machine, but if you absolutely must fit more software on the drive than will fit in its native space, compression is your only choice. In that case, stick with the FAT 16.

- Now is a good time to load your antivirus software too. If you have Norton, put it in. If you don't have a good antivirus already, go to <http://antivirus/cai.com/cgi-bin/ipe/connect.cgi> and download the FREE InoculateIT. The magazines say that this software is as good as the expensive stuff and, did I mention it's FREE? There is no excuse for running a machine without this protection—you will be protecting yourself and everyone in your address book.

The second method, or direct Win 98

install, sounds simpler, but it can be very difficult to get it working in practice:

1. Make a diskcopy of your Windows boot disk, and make sure it boots up your machine to a C: prompt.

2. Copy the Win 98 driver file (the .inf file) from the Win 98 directory of your external CD ROM drive's drivers disk to the boot disk you just made. (If you lost your floppy disk with the drivers on it, you can download them from the manufacturer's site. EXP's site will allow you to download a file that recreates the driver disk on a fresh floppy.)

3. Modify the config.sys and autoexec.bat files to add the driver commands to the boot disk. This is the hard part. You will need to know which interrupts are available for the CD and modify the command line in the Config.sys file accordingly. Here are the lines from my customized Win98 boot disk for reference:

```
[in the config.sys file add:  
device=expcdi.exe /P:3 /I:10 /D:cd]
```

```
[in the autoexec.bat add: LH  
MSCDEX.EXE /D:cd /L:D ]
```

Note: the word "cd" in the two expressions above are labels of convenience; but they must be the same word in both the config.sys and autoexec.bat files. And of course, the number following the "I" is the interrupt. Read your computer's manual for available interrupt suggestions. Try 11 or 14 if 10 doesn't work.

4. You'll know when it's working because the lights will come on in your external CD, and it will start preparing to install Win98! From that point on, just let it format the drive and install the OS!

Now, you can also skin this cat other ways. You can, theoretically set up a LapLink program to use a floppy on another machine, but I've never tried that. Linux fans may also have ways to install that OS, but that's beyond this article. You may also find a version of Windows on floppy disks, in which case you may not even need an external CD ROM. However, the only floppy version of Windows I've come across is Win 95 (1st Edition) which is a rather poor choice these days, since it is six years behind current systems. Nevertheless, you can climb the ladder from a set of these disks, using updates, and that way you won't need to install DOS first. If you already have Win95 on floppies, one alternative would be to start off with Win95; then you can install the CD

ROM drivers for Windows and use a Windows 98 upgrade CD. The experts say upgrades are less desirable than so-called "clean" installations of full versions. Like I said, there are several ways to skin this cat. I prefer doing a clean, original installation of Win98 SE.

Now, what do I do with this new toy?

You will have a sense of satisfaction when you see Windows come up cleanly the first time. Bask in the glow for a moment, and then start thinking about

what you want the machine to do. The machine should be able to handle most ham-related programs with ease. The sound cards in the Portege machines appear to be compatible with all of the current ham software. I have Digipan running on all these machines, and I have experienced no problems at all. There is no question that serious DSP crunching will tax these little computers, but for field work, or even utility work in the shack, they're perfect. I have even taken to using my 300CT in the shack with the multimedia

docking port when I am home. The big desktop has a noisy fan, so I just leave it off. Of course, I can't promise you that any specific program will work, but they do for me.

PSK 31 and Digipan are a must, of course. The mode was made for QRP! In addition, you might want to try some of the other "designer" modulations, such as multi-tone FSK. Logging programs should also work quite well. You might also want to add Gram, or one of the other popular signal analysis programs. Enjoy!! ●●

Four Days in May—Dayton Hamvention 2002

Please mark your calendars and make your arrangements to attend the QRP premier event of the year, the Four Days in May (FDIM), scheduled for May 16, 17, 18 and 19, 2002 at the Dayton Hamvention. For a more detailed explanation of this year's event and a view of the several past FDIM events, please visit the QRP ARCI web site @ <http://www.qrparci.org/> and click on the FDIM-Dayton link. Last year, over 300 QRP enthusiasts participated in the FDIM 2001 event. Make sure that YOU are part of FDIM 2002!

For those who are not familiar with the FDIM event, this event starts one day in advance of the three day Dayton Hamvention. This is the reason for the name, FDIM, as we add a fourth day to the Dayton event to provide a special day just for QRP seminars and get togethers/socials. The FDIM does not conflict with any of the daytime Dayton Hamvention events, while providing QRPers two additional evenings of QRP vendor displays, QRP building/design & display events, a special QRP banquet and opportunities to meet many of the our fellow QRP enthusiasts face to face. You gotta come and feel the power of QRP!

Registration

All registration information will soon be on the QRP ARCI web site @ <http://www.qrparci.org/>. For your convenience, QRP-ARCI accepts payment through PayPal!

Hotel

The official motel for all QRP activities is the Ramada Inn Dayton Mall which

was previously the Days Inn South Dayton. Send email to our room coordinator, Hank Kohl, k8dd@arrl.net, if you want to be on the list. The rate is still being negotiated, but it will be very competitive for Dayton this weekend of the year.

Events Overview

Here is a brief rundown on the tentative schedule of the FDIM event:

Thursday - May 16, 2002

QRP Symposium: 8:00 AM to 4:30 PM
Contribution: \$15.00. Topics include:

"Solar Power," Mike Bryce, WB8VGE (prosolar@sssnet.com)

"SMT Technics," Peter Zenker, DL2FI (DL2FI@online.com)

Several other very interesting presentations are being planned so keep tuned to QRP-L, QRP-F and the QRP ARCI web site @ <http://www.qrparci.org/> for up to date announcements.

Thursday Evening - May 16, 2002

Author Social: 7:00 PM until 11:00 PM
No charge. A chance to meet and talk with the QRP Symposium Speakers.

Friday Evening - May 17, 2002

Vendor Social, starting at 8:30 PM
No Charge. This evening is set up to allow the QRP vendors to display, demonstrate and discuss their products and latest offerings with YOU, their target audience. You get a better chance to talk to the Vendors without the other 29,000 Amateur Radio Enthusiasts!

Saturday Evening - May 18, 2002

QRP ARCI Awards Banquet:

7:00 PM to 9:00 PM

\$25.00 per ticket. This is the annual QRP ARCI Awards Banquet honors QRPers who have made major contributions to QRP and Amateur Radio. We will have a special speaker and announce the winners of the various "build it contests." We will hand out fabulous quality and quantity of door prizes as well as have lots of fun!

Later Saturday Evening - May 18, 2002

Displays PLUS the Radio Show:

9:00 PM to ? (after the Banquet)

No Charge. This provides QRPers time to socialize and view the displays of the Building and Design contest entries and winners. Plus, you can display and show off your projects and collections at the Radio Show!

For the latest on the building and design contests, please visit the QRP ARCI web site. <http://www.qrparci.org/>

Whew, can you believe the amount of activities planned? If you have been before, you know that you must come again. If you have not made it to FDIM in the past, this is a "Must Attend" type of event. You will not be disappointed. Please continue to monitor QRP-L, QRP-F and the QRP ARCI web site at <http://www.qrparci.org/> for additional updates and details.

—Tom Dooley, K4TJD

FDIM Chairman

tdooley@atl.mediaone.net

●●

Digital QRP Homebrewing

George Heron—N2APB

n2apb@amsat.org

DDS frequency synthesis continues to be a hot topic and the technology gets better every day. Our spotlight project this issue is the "kit" that started it all—the WB2V DDS VFO—and we'll add some mods to make it hotter yet. Plus, our evolving design of the Digital QRP BreadBoard takes shape now with availability of the HC908 Daughtercard and the first software program for homebrewers building the project along with us. So once again, warm those soldering irons and fire up the source code editor because we're going to have some more fun with microcontroller projects.

We received lots of positive feedback on the 3-part format of this column introduced in our inaugural column last time. It seems there is indeed a thirst for microcontroller-related projects, and our approach of spotlighting a kit already on the market and providing mods for it is of great interest to QQ readers. Such a project is easy to do when you already have the inexpensive base kit or when you can still obtain it from the originating QRP club or designer.

We received even further encouragement on the evolving design approach taken with our Digital QRP BreadBoard project. When complete, this 6" x 9" board will serve as more than 15 different accessories on your workbench, on your radio table, and in your backpack for field use—all by merely downloading different software to it from your PC. Talk about flexibility! Couple all this with free development software, no extra programming hardware needed and availability of an inexpensive bag-o-parts BreadBoard kit, and you have a winner project.

Our online companion to this column, the Digital QRP Homebrewing website (www.qrparci.org/digitalqrp) received hundreds of visits within its first week of opening. QRPers are finding that this website contains much more detailed material than we can include in this printed column. It presents a continual flow of information in a timely manner, and we think homebrewers appreciate that kind of technical accuracy and completeness in our projects. Visit our "online column" often to stay

current in between printed issues of QQ.

So let's get into this issue's projects: a DDS VFO and the first application for the BreadBoard project—a scaling voltmeter.

Spotlight on... The WB2V DDS VFO

Some years ago, specifically in July of 1997, Curtis Preuss, WB2V presented a mini-landmark article in the pages of QEX entitled "Building a Direct Digital Synthesis VFO." Curt had obtained one of the then-new AD9850 DDS chips from Analog Devices and he constructed an experimenter's breadboard consisting of that DDS chip, a PIC microcontroller and an LCD display in order to demonstrate the ease and flexibility of producing a fair quality, digitally constructed VFO.

FAR Circuits provided the pc board then (still available today), and many

homebrewers used this DDS project over the years as the basis for their own DDS VFO experimentation. In fact, in that same era, the Ham-PIC users group formed and a number of us started optimizing the original PIC16C54 program, adding extra capabilities, converting over to the more user-friendly PIC16F84, and generally learning lots about PICs and DDS chips along the way. An entire collection of these mods and software updates is posted on the Ham-PIC Resource website. (See Note 4 for the web page's address.)

The Original Circuit

The entire DDS VFO article is posted (with permission) on our companion DQH website, but the schematic is reproduced here in Figure 1 for easy reference.

A Microchip PIC16C54 is the heart of the project, taking input from a shaft encoder S1 and sending frequency control commands to the AD9850 DDS at U2. The

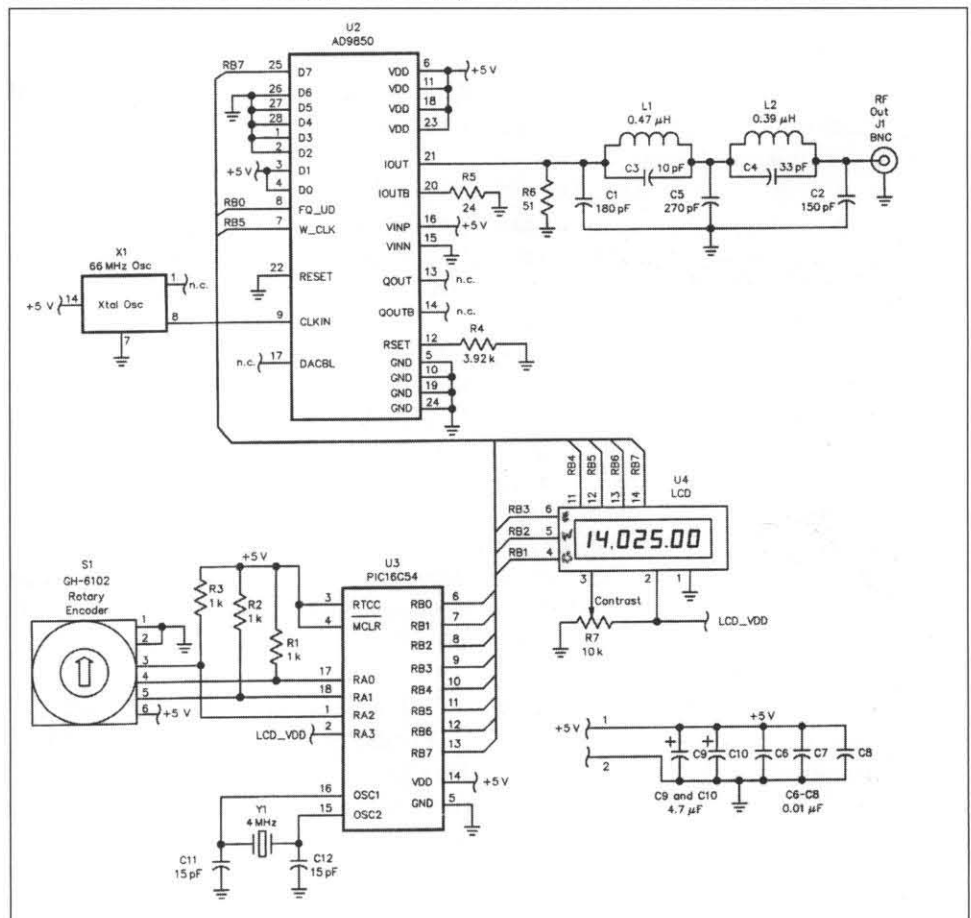

Figure 1. Schematic of the WB2V DDS VFO. (From July 1997 QEX, reprinted with permission of the ARRL.)

LCD (U4) displays the specific frequency being output by the DDS.

The DDS chip contains a 32-bit phase accumulator, a 1-bit look up table and a 10-bit D-to-A converter. When clocked at 66 MHz, a maximum usable frequency of 20 MHz is possible after applying a low pass filter

as shown on the "Iout" output pin 21. The DDS frequency is set by the PIC sending a 32-bit frequency control word, 3 control bits and 5 phase-modulation bits serially to the 9850. Turning the shaft encoder commands the PIC microcontroller to send new frequency and phase information to the DDS, which is also reflected in a new text string sent to the LCD.

The Evolution Begins

Several homebrewers were quite active on the Ham-PIC mail list, contributing their observations and modified programs to the Resource Page for others to use. Craig Johnson (AA0ZZ), Bruce Stogh (AA0ED), and most recently Chuck Olson (WB9KZY) have made some of the more prolific changes to WB2V's the original design, adding calibration, memories, altered tuning rates, and more.

Another notable homebrewer experimenting with the code was Ron Taylor, G4GXO. Ron decided that the tuning was too slow when used as a VFO in his custom-designed transceiver and he determined that he could significantly speed up the tuning rate by splitting the control and display software in the PIC into two PICs—which is where our real story actually begins this time, told in Ron's own words.

Fast Tuning DDS System Using 2 PICs

"After building and using an AD9850 DDS synthesizer based upon information from several DDS and PIC projects, I very quickly came to appreciate one of the chief limitations of the single-PIC control system, particularly when used in synthesizers employing a 'slow' LCD frequency display.

"The problem with the type of configu-

ration shown in Figure 1 is that for every tuning step the processor has to perform a complete program cycle, often involving long iterative computations and slow dialogue with the LCD processor. The time taken for these activities limits the number of frequency tuning steps that the system can execute over a given time period, and if not compensated for in some way, it would produce an unbearably slow tuning rate. A couple of techniques are used to overcome this. Firstly, variable rate tuning is used whereby the frequency step size increases with the speed of rotation of the tuning control. Secondly, a rotary encoder of relatively few increments per revolution is used to allow a reasonable rotation rate with the variable step rate function.

"I found the variable rate tuning off-putting and at times difficult to use. After attempting without success to improve on the scheme, I decided to try a new approach, with the aim of producing a true 'VFO feel' to the tuning.

"I rebuilt the synthesizer, exchanging my home made 32-step ex-PC mouse shaft encoder for a reasonably priced 512-step HEDS 9100 encoder from Farnell. I then adapted a fine piece of software called siggen3a, jointly developed by WB2V, AA0ED and AA0ZZ. This software was designed to operate on a single PIC DDS system for use as a signal generator or local oscillator for direct conversion transceivers. The very logical program structure and highly comprehensive line documentation was a real benefit. Having never programmed PICs before, I used this program as a combined tutorial and crash course in 16F84 programming! I first modified the LCD routines slightly to make them compatible with my display. Next, I added an IF offset routine to adapt the sys-

tem for use with my Belthorn SSB IF module. Once I checked that the software worked in a single PIC system, I took the bold step of splitting the software into two programs each running on a 16F84 PIC - one to scan the controls and manage the DDS, and the other to convert binary frequency data into ASCII and manage the LCD. A simple serial interface allows the two PICs to communicate.

"Referring to Figure 2, both PICs are clocked at 8.86 MHz (my transceiver has a 10 MHz IF and these crystals just happened to be available and were far enough away from the IF frequency so as to avoid interference.)

"The key to increasing the system tuning speed is that both processors run independently, allowing the tuning and display processes to run in parallel until the LCD PIC calls for the current frequency. When this happens, the DDS PIC passes the frequency word over the serial interface and resumes scanning the controls and managing the DDS. Once it has received a new frequency update, the LCD PIC processes it, formats it and feeds it to the LCD processor for display. An additional 10 ms delay in the frequency request routine further increases the time available to the DDS PIC for the tuning process. The result is a nice 'VFO-like' tuning action with 10 Hz steps and a 10 kHz per revolution (double encoder size) tuning rate. Despite the resultant display lag and delays, the processes run fast enough so as not to be noticeable to the eye. The tuning action limits at about 2 revolutions per second. With further program and hardware optimization, this could be increased significantly. For example, the IF shift routine resides in the DDS PIC to allow USB/LSB switching with my single crystal carrier

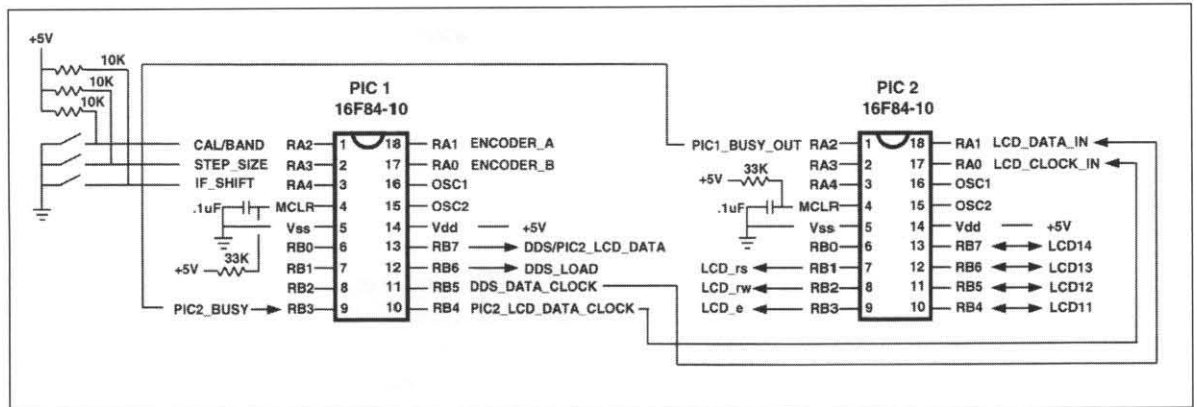

Figure 2. Dual PIC-controlled DDS synthesizer.

oscillator and typically asymmetrical ladder filter. With two carrier crystals and a symmetrical lattice filter, this routine could reside in the LCD PIC, freeing up processor time for the tuning routines.”

Reproducing the Dual PIC DDS VFO

Recalling that in this portion of our Digital QRP Homebrewing column we like to present modifications to already-available kits, we'll next present some guidelines for those readers wishing to create a dual-PIC version of the original WB2V DDS VFO.

The first order of business is getting the original VFO circuit built and working. The circuit boards are still available from FAR Circuits (see Notes section), as are the AD9850 DDS chips. The more modern PIC16F84 can be used in place of the 16C54 and the software is available on the Ham-PIC Resource Page.

Once the original DDS VFO is working (or perhaps you had one built previously!), you can add the second PIC, following the schematic in Figure 2. The software for each PIC processor in the G4GXO system is downloadable from our column's companion website—just program the PICs using your EPIC programmer, MPLAB, or whatever convenient method you have to get the programs into the PICs.

Since the time of G4GXO's experimentation, Craig, AA0ZZ and Bruce AA0ED have evolved and optimized this dual-PIC solution even further. You can see their software programs on the Ham-PIC Resource Page.

So There You Have It

There's no reason why you too cannot have a DDS VFO and play alongside the digital guys. My DDS VFO is used at times as a plug-in replacement for the VFO in my Sierra transceiver, as a signal source for the bench, or as an LO for a direct conversion transceiver ... the possibilities are endless!

The Digital QRP BreadBoard

In the previous installment of this section, we overviewed the concept and goals of the BreadBoard project. This time we're going to get into the details of the first hardware and software blocks—the micro-

controller “heart” of the system, some I/O in the form of a keyboard and LCD, and an analog input port that will serve us in the first BreadBoard application—a simple scaling voltmeter.

Background

For those tuning into this BreadBoard project for the first time, here's a brief recap of what's happening. The Digital QRP BreadBoard is an evolving homebrew project being designed and presented in this column, serving as a general purpose QRP accessory that can be used on the operating bench and in the radio shack in a variety of ways. Approximately 6”x9”x1.5” in size, this project contains a number of peripherals that QRPers find useful in applications around the shack—an LCD, shaft encoder, DDS chip, audio amplifier, RS-232C serial port, general purpose I/O buffers, and a daughterboard expansion port all provide convenient design flexibility.

You'll be able to download new software from this website and reprogram your Digital BreadBoard, allowing it to serve as a memory keyer, an audio filter, a keyboard-driven data terminal, a controller for your HF rig, a frequency counter, and more. Sharp readers will glean that we'll even be able to make an inexpensive portable PSK31 controller with the DSP daughterboard to be introduced in a near-future installment of the Digital BreadBoard project.

The Digital QRP BreadBoard is being

offered as a kit. See reference 2 at the end of this article for ordering details.

The Microcontroller

We selected the popular Motorola 68HC908AB32 microcontroller as the heart of the BreadBoard project. It was necessary to select such a CISC (complex instruction set controller) instead of a low-end RISC (reduced instruction set controller) like those in the Microchip PIC family. The software already being designed to control the many peripheral chips and I/O functions would be present great programming challenges in a RISC device because of inherent program memory and register memory addressing restrictions. The 'HC908 is the Motorola equivalent of the popular 8051-class of processors from Intel, SST, and others offering plentiful I/O capabilities, unrestricted addressing and high clock speeds.

Another deciding factor in the selection process was the massive amount of I/O pins available for controlling all the hardware peripherals in the system—the LCD, DDS, pushbuttons, LEDs, 7-segment displays, keyboard, keypad, serial port, et al. Eight separate I/O ports provide up to 51 general purpose input and output pins. Many of these pins are software configurable to serve as analog interfaces, contain integrated pull-up resistors, and couple to the interrupt structure of the processor. We'll truly be able to work wonders in interfacing the HC908 to all the devices we want to control.

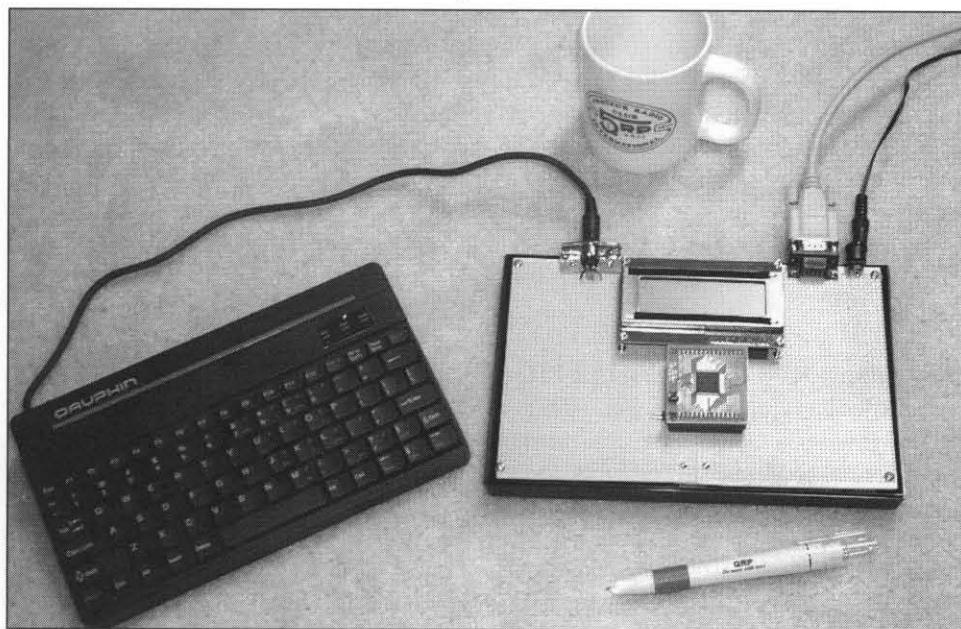

Figure 3. Digital QRP BreadBoard—Phase 1.

Working in conjunction with the physical I/O pins, the HC908 has some internal macro functions that greatly ease the programmer's job. The microcontroller has built-in modules for asynchronous communications providing an RS-232 serial port, timer modules for frequency counting and timing, programmable interrupt timing for precise interval control, an 8-bit/8-channel A-to-D converter, a keyboard interrupt module, and a watchdog timer. This microcontroller is really quite amazing and is perfect for use on our BreadBoard.

Plentiful memory is a must for a CISC microcontroller being used in a large application such as ours. Our HC908 has 32 kilobytes of flash memory that will hold the software program itself. There is 1 kilobyte of RAM space available for data variables and other time-changing data. The controller also has built-in EEPROM (electrically erasable programmable read only memory) that will be used to store user-set configuration, calibration and custom string data that needs to be used every time the BreadBoard is turned on.

From a software perspective, the HC908 supports an enhanced version of the Motorola HC05 programming model. It has 16 addressing modes (direct, indirect, indexed, etc.), a 16-bit index register and stack pointer, and extensive loop controls (e.g., BRCLR n). It supports memory-to-memory data transfers and can perform fast 8*8 bit multiplication and 16/8 division. These last two capabilities will prove quite valuable when it comes time to scale input values and calculate SWR, power, and filter coefficients. Finally, the microcontroller's hardware and software architecture is optimized for controller applications and for C-language support as we'll see downstream when the Metrowerks "Code Warrior" development tool is presented.

The HC908 Daughtercard

Although not yet mentioned, sharp readers would probably suspected a potential problem with our selection of the 68HC908AB32 microcontroller. A device having so many pins (specifically 64) would be required to be packaged as a PQFP surface mount device—a plastic quad flat pack. But not to worry! There is a plan...

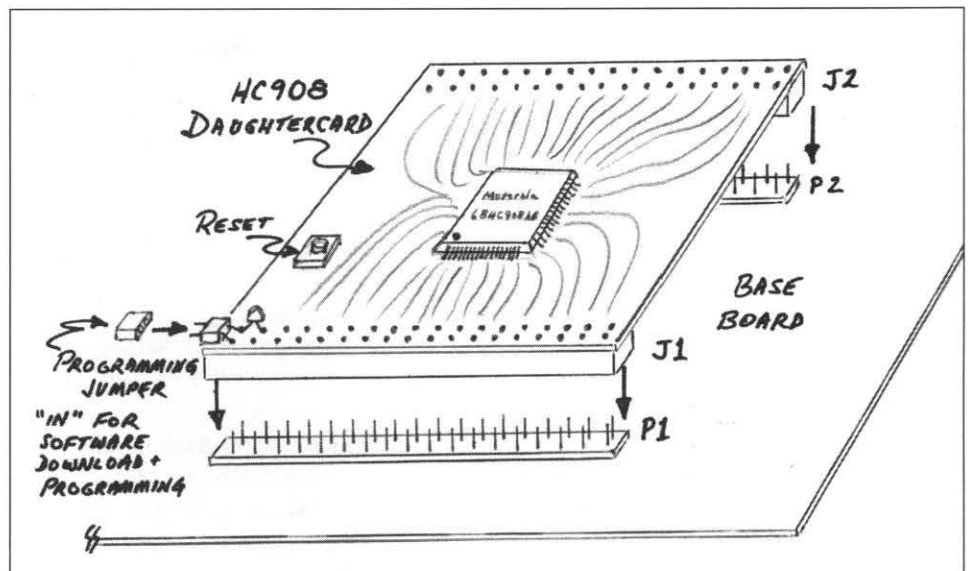

Figure 4. Daughtercard on Base Board.

To enable homebrewers to start building right away, we've created a 2" x 2" pc board for the surface mount HC908 microcontroller.

Also contained on this daughtercard are the components required for clock generation, a MAX-232 chip for serial communications, a voltage regulator and a RESET pushbutton. All I/O pins of the HC908 are brought out to edge connectors that permit this daughtercard to be plugged into mating pin headers on a prototype base board containing all other components. Once the design has solidified and stabilized in the coming months, the microcontroller daughtercard can be unplugged and transferred to the pc version of the base board.

The HC908 Daughtercard is shown in Figures 4 and 5. The 64-pin PQFP device is soldered in the center of the card's top side and its many I/O pins are connected by top-side traces to two 34-position sockets located on either side of the card. These long sockets will plug into mating pin headers located on the base board, as illustrated.

A small pushbutton is also provided on the top side of the daughtercard. This normally-open momentary contact switch serves as a manual RESET for the system.

A 2-position pin header and LED are mounted in the lower corner of the card's top side, serving to configure and indicate the boot loader feature. (More on this feature in the Programming section.)

The bottom side of the Daughtercard contains the surface mount components required for clock generation on the microcontroller—a crystal, two capacitors and a resistor. Also located on the bottom side are the LM78L05 3-terminal voltage regulator and associated filter caps, and the components used for serial interface—the MAX-232 level translator for the RS-232 communications port and the five electrolytic capacitors used for charge

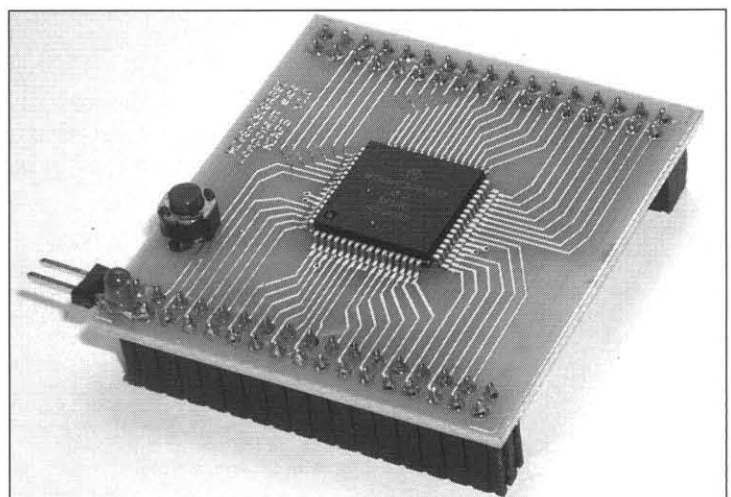

Figure 5. HC908 Daughtercard.

pump operation.

Creating a daughtercard in this manner for the microcontroller proved to be a very enabling decision. Besides being able to transfer the card from the prototype base board to the final pcb base board, one could easily use the HC908 Daughtercard for other applications. There is lots of capability in this little 2"-square standalone card—just supply 9-12 Vdc and a serial comm line from your PC and you'll be able to download and burn new programs into your HC908 microcontroller.

Getting Software into the HC908

One of the prime goals for this project was to have the BreadBoard be easily and inexpensively reprogrammable, even after built and used long-term by the homebrewer. Of course the unit has ample onboard flash memory, simplifying the board design and making for a non-volatile project. (That is, the microcontroller retains its program memory even when power is removed.)

But getting the software program into the device is sometimes a concern for microcontroller homebrew enthusiasts due to the expense of the "programmer." Oftentimes it's necessary to purchase a \$100-or-more programming board from

the manufacturer that will allow you to burn your custom software into the controller's flash memory. In many cases one is able to homebrew this programmer (as in the case of the PIC devices), however this is yet another project that must be done before getting to the fun part of experimenting with your intended project.

However the good news is that our 68HC908AB32 device has the ability to be in-circuit programmed, which means that a conventional +5 V power supply and proper timing is all that's required in order to burn a new program into its flash memory ...even while on the target pcb of your project! We've developed a special boot loader program that allows you to download the binary image of your program over the built-in RS232 serial data port connected to your PC. All you need to do is develop a program with the (free) software development tools on your PC, download it to the BreadBoard and bingo, you'll be running your new and improved program. In this way you'll be able to take advantage of newer software programs that we'll be providing for download on this website, or you can develop your own customized versions of the programs. Pretty cool, eh?

When it is time for you to get a new

software program into your HC908, connect your PC's serial port to the daughtercard, install the jumper on the Boot Loader pin header and then press the RESET pushbutton to reset the processor. The daughtercard's LED will illuminate, indicating that the boot loader software is running. You'll next transfer the binary file of your new software from your PC using a communications program like HyperTerminal (standard in the Windows Accessory folder). Once the software is downloaded to the HC908 controller, the boot loader proceeds to burn the software into the controller's flash memory. When successfully completed, the daughtercard's LED is turned off and the new program be run. (More detailed instructions for this boot load operation are supplied in the kit manual and on this column's companion website.)

1st Program: Scaling Voltmeter

If you're intending on building up the Digital QRP BreadBoard and experimenting along with us in this journey, the first thing you'll need to do is order the HC908 Daughtercard. It comes assembled, tested and pre-programmed with the boot loader program, and with the first software application for our BreadBoard—the Scaling Voltmeter program.

The Scaling Voltmeter software program is designed to read an analog input port, scale the value to reflect the actual voltage, and display that voltage reading on the LCD. A standard IBM-compatible PC keyboard is used by the operator to input the scaling factor and to command the readings to be started. The program may be used to read the relative power by connecting the analog input pin through a suitable interface circuit to the RF output of a transmitter. Refer to the diagram in Figure 6 for an example application.

The voltmeter program is constructed by designing some common libraries of routines for: LCD output, keyboard input, analog input, system initialization, and for the math that performs the scaling. These routines are "glued together" in the main-line of the program that executes when power is applied to the system. The liberally-commented source code for this software program is posted on our companion website and is available for individual scrutiny. The website also goes into much greater description on the software con-

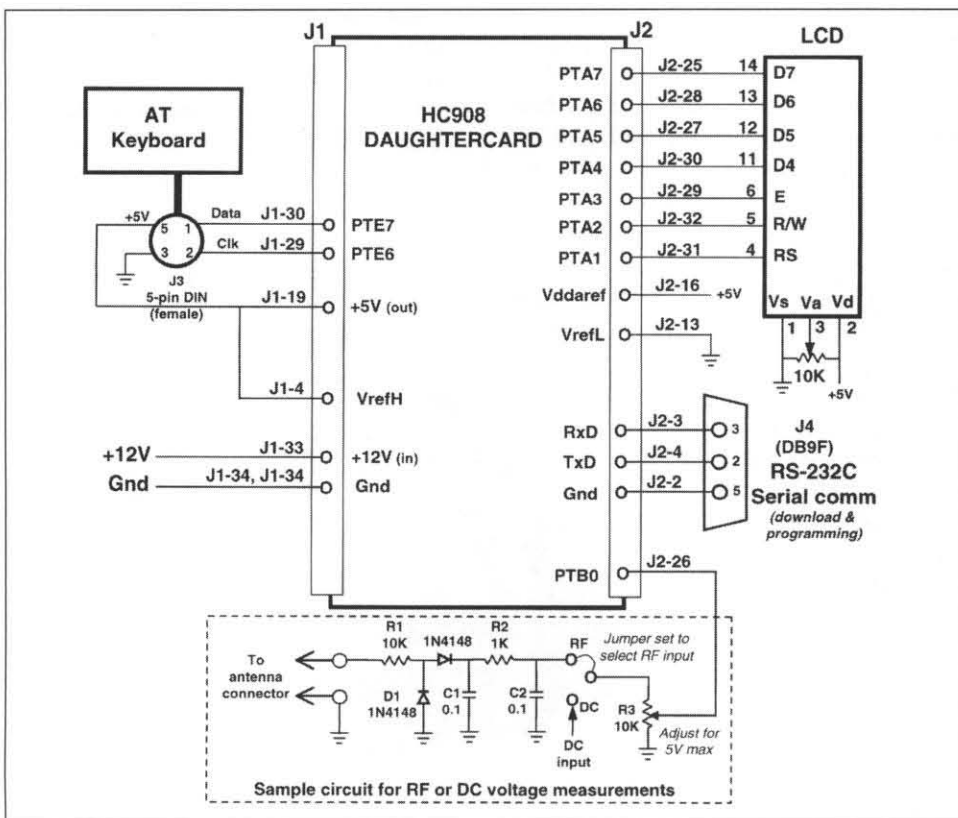

Figure 6. BreadBoard Phase 1—Scaling Voltmeter.

struct and operation, thus providing an instructional tutorial, of sorts.

Gathering parts for the building up the first BreadBoard project is very simple. The HC908 Daughtercard is available from the NJQRP Club. The IBM-compatible keyboard can be borrowed from your main PC, or you could obtain a \$10 surplus mini-keyboard like the Dauphin unit pictured in Figure 3. The LCD can be any standard 2-or-4-line display sporting the popular Hitachi 44780 controller chip. (Digi-Key and Jameco have several applicable displays.) Just ensure the connecting pins match the functions shown on the BreadBoard schematic diagram. Then all

you need to do it get a few diodes, caps and resistors for the analog interface, melt some solder to hold it all together and apply a 12 Vdc power supply. If all is wired properly, you'll see a welcome message displayed on the LCD and you'll be in business!

Don't Forget to Visit the Website

We'll really start picking up steam now and you should frequently visit this column's companion website. (See Note 1 for the URL.) We already have lots more material posted concerning this first application, and we'll be giving some insight as to the next functional block to come alive.

Next time in these pages we'll be adding some exciting frequency synthesis capability to the BreadBoard, leveraging the DDS VFO project described in the first section. Everybody loves a VFO...well, we're shortly going to have a real flexible one to use as a frequency generator, a local oscillator, a test source, and more. Join in with us and stay tuned for some real fun coming this way!

73, George N2APB

Acknowledgements

Special thanks go to Craig Behrens, NM4T, who has been a collaborator, an enabler and a major cheerleader for the Digital QRP Breadboard project. His encouragement and contribution has been a decisive factor in bringing this project to the QRP community.

The Digital QRP Breadboard kit is being provided by the volunteer efforts of NJQRP Club. Parts procurement, manual publication, order processing and sorting/shipping operations are being handled by the club's "kitting team"—AA3UR, WA3OWT, KE3S, NU3Y and N2CX—thanks guys!

Notes

1. Digital QRP Homebrewing website located at: www.qrparci.org/digitalqrp.
2. Preuss, Curtis W, WB2V, "Building a Direct Digital Synthesis VFO," *QEX*, July 1997. *QEX* is a publication of the ARRL. (This article is completely reproduced, with permission, on the Digital QRP Homebrewing website.)
3. FAR Circuits, 18N640 Field Court, Dundee, Illinois 60118. July 97 *QEX* DDS board available for \$7.50+ \$1.50 shipping.
4. Ham-PIC Resource Page, located at www.njqrp.org/ham-pic, contains the source code files for many of the modified versions of the DDS VFO program.
5. Ron Taylor, G4GXO, 89 Belthorn Road, Belthorn, BLACKBURN, Lancs, UK BB1 2PA. E-mail: ron.taylor@cwcom.net.
6. Digi-Key, www.digi-key.com
7. HC908 Daughtercard—sembled, tested, with manual, pre-programmed with the software in this column. Send \$25 check or M.O. to "George Heron, N2APB," 2419 Feather Mae Ct., Forest Hill, MD 21050. (DX orders add \$5 extra.) PayPal payment also accepted, send to n2apb@amsat.org.

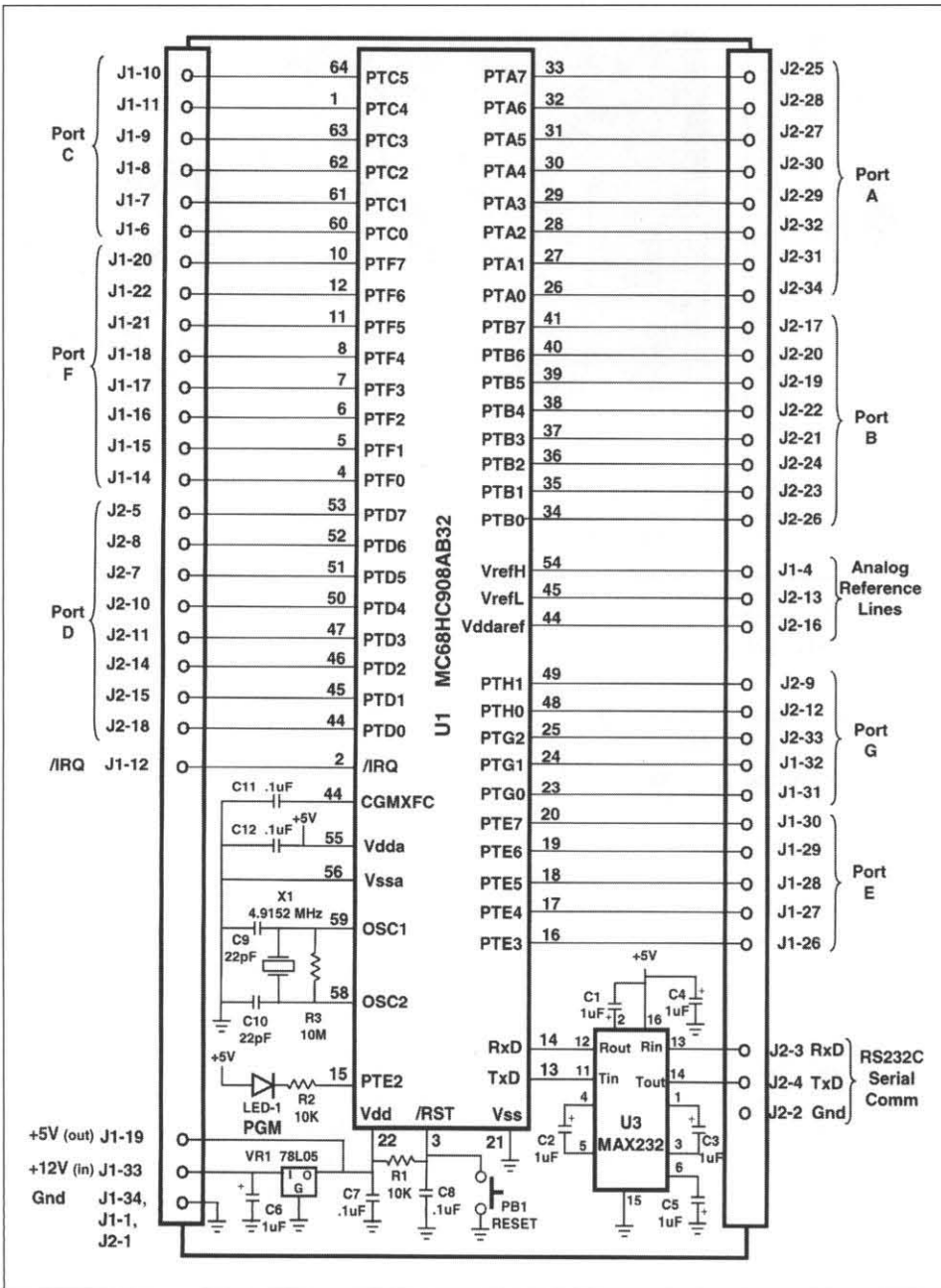

Figure 7. Schematic for the Digital QRP BreadBoard system—Phase 1.

The FT817-Paddle Combo

Dick Arnold—AF8X

I have two excellent pieces of equipment, the Yaesu FT 817 and the Palm Mini-Paddle, which I have combined into an integral unit. The Mini-Paddle comes with an optional magnetic base, however, there is no where on the FT 817 where it can be placed and be in a comfortable operating position, so using this paddle meant attaching it to some kind of base and operating on the desk top in the conventional manner.

The FT 817 has the option of keying

the built-in keyer with the mic up and down buttons, enabled in menu # 36. I took advantage of this feature and modified my Mini-Paddle by installing an RJ 45 plug in the base and added an offset tongue to engage the strap bracket on the rig. The paddle may still be retracted into the housing just as it was intended. To attach the paddle you first engage the tongue into the slot of the strap bracket, and then swing the assembly inward to insert the plug until the locking click is

heard. This secures the paddle in an ideal operating position. The paddle can be left attached unless the microphone is needed for phone operation, then a thin piece of whatever is handy, can be inserted between the rig and paddle to release the locking clip on the RJ 45 plug. The paddle may then be removed in the reverse order of attachment. I have found that having the rig and paddle configured this way is preferable especially when operating portable. ●●

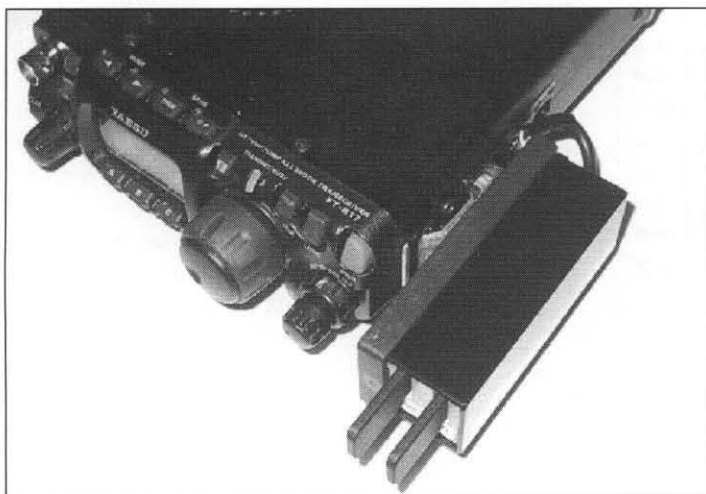

FT817 with the paddle attached...

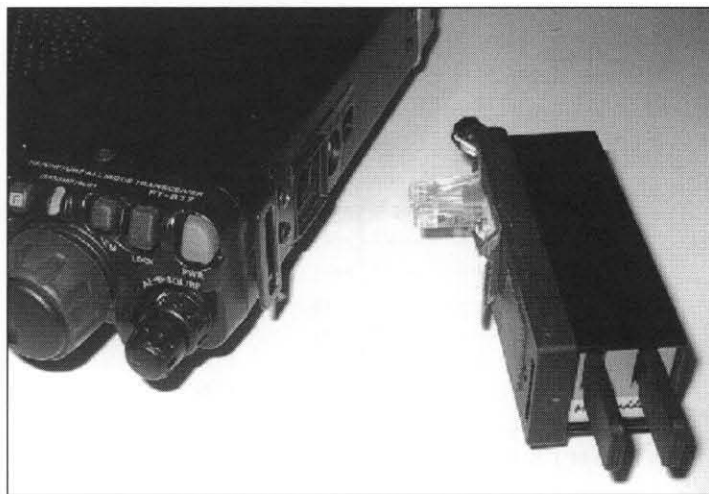

...and with the paddle detached.

“TOAST” – QRP Transceiver of the Near Future?

The QRP transceiver of the near future will be almost indistinguishable from a normal notebook. More exactly, what you see will be a notebook. Only an expert will be able to find it on the Ham desk.

The virtual front panel of the transceiver with the control elements will be displayed on the smaller part of the notebook's display, driven by a trackball. The call signs of all stations up the time on band and their frequencies will be on the bigger part of the display. Also displayed are geographic location and distance, signal strength, date of the last connection with these stations and if we have their QSL cards and what diplomas they are authorized for. On request, a record of the last connection can be displayed.

The operator can change the look and contents of the virtual front panel according to personal preference. The extremely high stability of the frequency will be provided by receiving exact signals from satellites.

The operator will choose from the displayed stations and will click on one call sign. In this way, the transmitter will be automatically tuned to the frequency of the selected station. The

connection is almost fully automatic. The computers exchange basic information about their operators such as name, address, personal photo, data and picture of their transceiver, picture of their town, local time, and other circles of interest the station offers as a subject of discussion. This information is displayed on the screen and during the connection, a complex picture of the other operator is shown. Both operators can then react to, and discuss the displayed information.

The station logbook will be automatically filled out. The stations will be able to automatically exchange virtual QSL cards during a connection and the "cards" will be stored in the PC memory. A true luxury will be the printing of a classical (paper) QSL card, and having it sent via "snail mail" (by request only!).

The transceiver will be in the form of a very thin box, located under the notebook as a pad. The changing of bands will be achieved by exchanging the whole transceiver. Each of these will be optimally adjusted to one band.

Because of its shape, it will be known as TOAST. Who will make them?

—Petr Prause, OK1DPX

<http://www.qsl.net/ok1dpx/future/toast.htm>

Freddy's Fabulous Frequency Finder

Bill Currie—VK3AWC

Victoria, Australia

[This note originally appeared in the March 2001 issue of "Lo-Key," the newsletter of the CW Operators' QRP Club (Australia) — on the web at: <http://www.users.on.net/zietz/qrp/club.htm> It is reproduced here by permission of Lo-Key's editor, Don Callow, VK5AIL.

—WIHUEJ

If you are like me, you probably have a box full of coils, chokes and old IF transformers that you drag out and look at every so often and then chuck 'em back into the box. You could make use of some of these unmarked treasures, if you knew a bit more about them. Knowing the inductance would be a big help—better still, if you knew which frequencies the things would cover you would know if you could use them or not.

Freddy's Fabulous Frequency Finder (FFFF) uses a two-terminal oscillator to test any RF inductors that you may have. The inductor is connected to the oscillator terminals and the frequency is read from your frequency meter. Provision has been made to connect sections of a calibrated double-ganged capacitor in series or parallel with the inductor under test. I used a 270 + 270 pF poly-varicon capacitor but an air spaced one with identical sections would do. Separate switches for SERIAL IN/OUT and PARALLEL IN/OUT are provided. The circuit schematic is shown in Figure 1 and a sketch of my FFFF is shown in Figure 2.

With both switches OUT, you can read

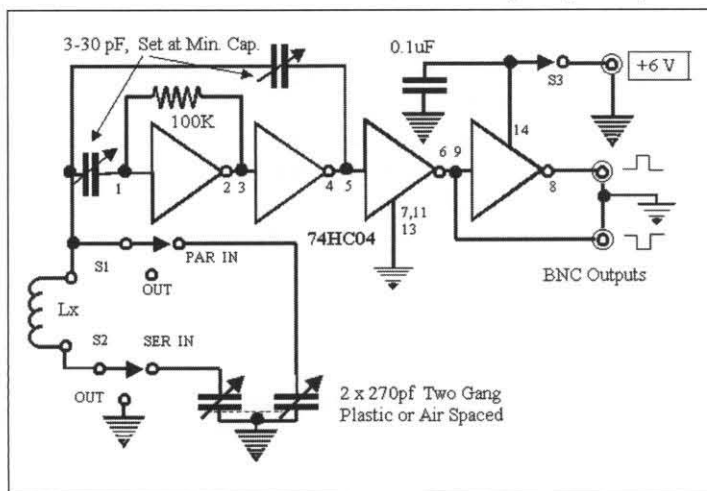

Figure 1. The circuit.

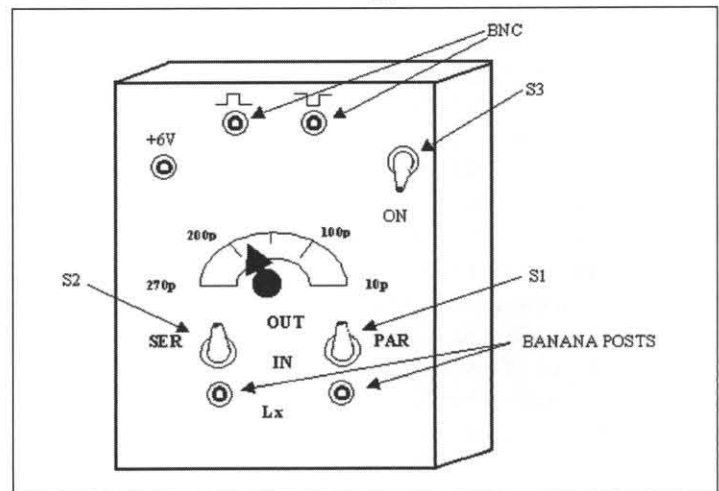

Figure 2. The box.

Math Corner

The formula for resonance in an LC circuit is

$$f = \frac{1}{2\pi\sqrt{LC}} \quad \text{with } f \text{ in Hz, } L \text{ in Henries and } C \text{ in Farads}$$

To find the Inductance using FREDDY

$$L = \frac{10^6}{4\pi^2 C f^2} = \frac{25,330}{C f^2} \quad \text{with } f \text{ in MHz, } L \text{ in microHenries and } C \text{ in picoFarads}$$

the resonant frequency of the inductor (with a stray capacitance of about 10 pF). By using the switches, you can determine frequency coverage by sweeping the capacitor from one end to the other. If you are winding coils, you can adjust the turns to give you the frequency you want with a specific capacitance. You will need to allow for the stray capacitance of course.

The circuit will operate from 5 or 6 volts and uses two sections of a 74HC04 Hex Inverter in a Franklin oscillator circuit. The two other sections are used as buffers to feed your frequency meter or as a driver for other use. You can of course use FFFF as a temporary VFO, a VXO or a VCRO (V Ceramic Resonator O) and for this application, a regulator such a 7806 or 78L06 would assist the stability of the circuit.

The FFFF is ideal for checking the frequency of crystals and ceramic resonators.

Just put the SERIAL and PARALLEL switches to OUT and connect the XTAL or Cer-Res. You will now be able to read the operating frequency. This frequency may differ from the marked value due to stray capacitance or lack of it. To see how much you can 'swing' the frequency, switch in SER or PAR or both. I found I could 'swing' a 7.200 MHz ceramic resonator from below 7.000 MHz to slightly above 7.300 MHz, with both switches IN.

You may wonder why I called this device Freddy's FFF—well it is in appreciation of the help that Freddy gave me in the design and testing of FFFF. By the way, Freddy is the shack cat and while not a great conversationalist, went out of his way to oversee the construction and testing phases of this project. Any donations of cat food (Freddy likes the Gourmet stuff) would be appreciated! ●●

QRP? Dah-di-dah-dit Dah-dah-di-dah

Mike Boatwright—KO4WX

ko4wx@mindspring.com

It was April 1991. After studying for my Novice exam and listening to code tapes for about two months, I decided it was time to try and become a ham radio operator. Bright and early Saturday morning, I drove over to Southern Tech and found the VE session. Nervous, and very unsure, I sat down to take the code test. The 20 WPM test sounded like machine gun fire. I could pick out an occasional letter of the 13 WPM session. Then came five words per minute.

For the first minute or so, I was totally confused and couldn't make head nor tail of anything. Then I heard something that made sense and letters started to appear on paper. When the test was finished, my heart was pounding. The guy giving the test said that we could pass if we had exactly 25 characters straight-one minute of solid copy-or could answer seven questions out of ten correctly. Looking over what I had written down, I knew there was no way I could answer the seven questions.

He told me to check over my work and make sure it was correct and then he'd check it over to see if I had gotten enough solid copy. Looking it over, I noticed that I had written down that the QTH was "Wackson, GA." I'd never heard of "Wackson, GA," but I had been fishing down near "Jackson, GA" before, so I erased the "W" and put a "J" in its place and turned in my work. Would you believe that I got exactly 25 characters of solid copy, including that "J"? And then I went on to not only pass my Novice exam, but the Technician exam as well! It was definitely a happy dance day!

Just before my ticket arrived in June, I bought myself a Radio Shack HTX-100 10-Meter radio. At the peak of an incredible solar cycle, KD4BDE worked the world on 25 Watts, SSB, into a dipole at 20 feet. My most memorable contact was with Australia, one night about 11 PM (Eastern time, US)—I think I received a 45 signal report, but I was ecstatic.

That fall, one of my elmers told me to "put down the microphone" and "pick up the key." At the Lawrenceville, GA, ham fest that November, I bought an old Heathkit SB-102 in the bone yard. The guy I bought it from gave me his address and

phone number in case I had trouble.

Well, I learned more about radio that next month or so trying to get and keep that radio on the air, let me tell you! He offered to buy it back from me, but in the end, after putting it up on his bench, we got it going. It never put out more than about 20 or 30 Watts, but I was able to use it on the Novice HF bands, so I was happy.

In January, I worked 90 stations in two weeks during the ARRL Novice Roundup (one of the last Novice Roundups—frankly, I am sad to see it go). Three days after the end of the contest, on a business trip to Raleigh, NC, I took my General exam, and passed the 13 WPM, first try! My elmer's advice and the Novice Roundup paid off!

Later that Spring, I passed my Advanced Test (one of the hardest exams I've ever taken—and that with a degree from Georgia Tech) and received the call, KO4WX that I still have today.

It took me two tries to pass the 20 WPM code test. At the Atlanta Hamfest in June, I failed the code miserably on Saturday morning, but passed the Extra written. They told me I could come back the next day and try again. They must have slowed the tape down a little on Sunday morning, because I was actually copying some code. No way I had a minute of solid copy, but I thought I might have a go at the questions. When I handed in my work, I told the examiner that I swore I heard the guy was operating with a "Carolina Window" antenna (think I had a problem with that code group, huh?). He swore that that was what he heard as well and he passed me!

I used to go to Field Day and watch the guys work CW all night long. They'd sit there chatting with each other, and still log the contacts into the computer and send the exchange back. I was in awe and dreamed that someday I could do the same thing. But I struggled with making CW contacts and am embarrassed to think about how many QSO's that were lost to "QRM" that were really because I was too embarrassed to send QRS.

Then about three or four years ago, I got hooked up with the North Georgia QRP club, joined QRP ARCI, and even went to my first FDIM this past spring.

I've always loved building stuff, ever since my grandparents gave me a Radio Shack shortwave radio kit when I was 8. Construction has always been my favorite part of the hobby.

Problem with a lot of this QRP gear that I have been building, though, is that it is mostly CW equipment. So somewhere along the way, I found that I really had to improve my code speed—while the FCC said I knew 20 WPM, but there was simply no way I could hold a QSO at anywhere near that speed.

So for the past few months, I've really been trying to get on the air and operate. Some of you have suffered through my QSO's, and I'm grateful for each and everyone. But last week, I copied down "NICE FIST"—you cannot imagine how good that felt!

As part of our effort to get folks on the air, the North Georgia QRP Club has sponsored a friendly "Worked All States in 2001" competition. Four guys have already earned it, and as I write this, I am one state away from mine (Nevada). How did I get all the states? Well quite a few came during contests, particularly, the Spartan Sprints, the ARS Bumblebee and the QRP ARCI QSO party. And then, at the beginning of November, I decide to have a go at the ARRL CW Sweepstakes.

Wow! Those guys really scream! Early in the contest, the code speeds are lighting fast. On Saturday, I only made about 20 or 30 contacts in about 5 hours, because I would have to sit and listen over and over to a station send its exchange, until I was sure that I had it right, and could follow the serial number sequence. But you know what? I did log the contacts, and did end up in their logs as well (I even have QSL cards to prove it!).

By Sunday afternoon, however, either they had slowed down considerably, or I my code speed had increased. I had my keyer set for 25 WPM, and found myself hearing a station call CQ (or QRZ?) and would call him right back, and get the exchange, first time! Whew!

So with some trepidation, I volunteered to be a "Cub Fox" this season. The Cub Fox Hut is basically the same as the regu-

lar fox hunt—the designated “fox” for the evening calls CQ FOX and works as many hounds as he can in a 2 hour period. It goes on for weeks, with the ultimate goal of whoever gets the most “pelts” wins the contest.

The difference between the Cub Fox Hunt and the regular hunt is that it is intended for the folks who can't scream along at 20 or 30 WPM. We usually go at about 10-12, but will slow down if necessary. Now you might think that 12 WPM is slow, but in 2 hours, I worked 43 stations—a personal record!

Where am I heading to with all of this and why is it the subject of this issue's column? Well, I used to think that a ham license gave me permission to test out my equipment—but that's often as far as I got. To be QRV means you are ready to operate—and that includes being ready to send and receive Morse code (if that's the mode your equipment is designed to operate, as most simple QRP gear is).

I need to remember sometimes that I need to “put down the iron and pick up the key!” If you've got that NOGAnaut working, get it on the air! Call CQ. If you are new to QRP, borrow a rig—most guys that build a lot of stuff, like me, have a few to spare and would gladly loan you a rig—and not only that, they'll come help you put up your antenna as well (thanks Mike and Sam!). If you are looking for somebody to practice with, send me an e-mail (ko4wx@arrl.net). I'd love to make a schedule with you!

If you love to build stuff, keep building, but get that equipment on the air! At

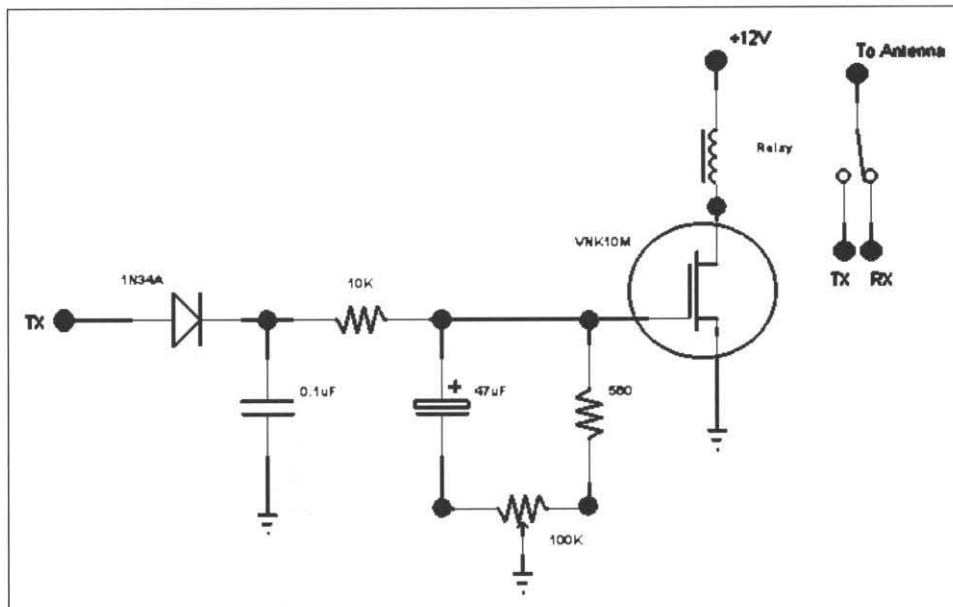

RF Sensing Transmit/Receive Switch

the beginning of this year, was still pretty nervous about holding a long QSO in CW. Now I am finding CW to be a whole lot of fun!

Hey, I Gotta Build Something!

OK, just to keep our irons hot until next time, here is a little circuit I have used to sense RF and automatically switch from receive to transmit. Try building this yourself Manhattan style (hint, draw the schematic on a piece of PC board and glue “pads” where the black “dots” in the schematic are—you're on your own to figure out how to hook up the relay, but try putting it upside down on the PC board).

I've seen circuits very similar to this in

QRP Quarterly before, but I arrived at these values experimentally. You can use just about any FET (JFET, etc.) that can take the current needed to drive the relay. The VNK10M is pretty robust and seems to do the trick for me.

The variable resistor sets the turnaround delay. If it is too slow for your tastes, try reducing the size of the electrolytic capacitor (or increase, if it is too fast). This won't give you QSK, but it's better than forgetting to switch to transmit before keying, like I often do...

Until next time, let's get QRV!

72 de Mike, KO4WX



QRP CALLING FREQUENCIES				
	CW		SSB	
160M	1810		1910	1843 Europe
80M	3560	3710 Novice	3865	3690 Europe
40M	7040	7110 Novice	7285	7090 Europe
		7030, 7060 Europe		
30M	10106			
20M	14060		14285	
17M	18096			
15M	21060	21110 Novice	21385	21285 Europe
12M	24906			
10M	28060	28110 Novice	28885	28360 Europe 28385 Novice

QRP Clubhouse—The Winter Doldrums

Mike Fletcher—KL7IXI/7

kl7ixi@attbi.com

As winter conditions force many of us of indoors, the great band conditions and lack of outdoor activities around the house encourage time in the shack.

But the winter months also mean opportunities for QRP clubs to generate meetings brimming with ideas and activities to keep members coming back for more. These ideas can also be used with radio clubs formed by our benighted QRO brethren. A couple of great QRP presentations or activities might cause these folks to see the light, and turn down the power. So for the next four monthly meetings, consider some of the following ideas.

How about manning a club station and participating in the Freeze Your B___ Off? This annual event, sponsored by the Arizona ScQRPions, is held in February. Outdoors, yet! Each of your contacts generate multiple points via a low temperature multiplier, the lower the better. Multiple operators are not only an advantage in this instance, they also help to keep spirits up. Having a bunch of your buddies around allows someone to help with creature comforts (such as manning a fire or a stove) and adds to the fun.

Consider also a winter QRP SwapFest during a club meeting. No doubt you have a few rare bargains lying around the shack, and could be persuaded to let go of them for a paltry sum. And then, with all that cash burning a hole in your pocket, you can bring home some new rare bargains, much to the delight of everyone (well, almost) in your household.

Develop an inexpensive kit to support club activities. Clubs can be very helpful in this regard. For instance, more than one ham has thought seriously about a project involving one of the FAR circuit boards, but has been put off by the idea of having to collect toroid coils, capacitors, resistors, antennas, useful accessories, and more. Many newer hams simply don't know how or where to collect these parts. And, ordering these parts in very small quantities can be pretty expensive. But, if a few club members get together and share a parts order, the whole idea becomes very feasible. The newer hams also gain the benefit of some built-in Elmers, and are

thus much more likely to consider building something.

You could also have a series of meetings to build and troubleshoot a common kit, such as the Tuna Tin 2, Stinger Singer Frequency Counter, or a copper J-Pole antenna. How many of the club members

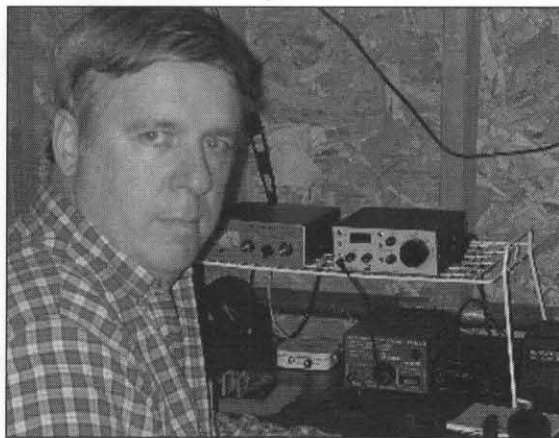

don't build their own gear because of a lack of test equipment and/or experience? Or, maybe they tried it once, had a bad experience, and are reluctant to try again. For even more enjoyment, consider having one of your more knowledgeable hams work up some notes on the kit, and explain how it works as the kits are being built. If you are really adventurous, have a class in etching a project PC board. Or, if the idea of regularly scheduled meetings doesn't work out, establish an on-call Elmer program. Then, if the new ham has a problem, he or she can easily find someone to bail them out. This is a win-win situation for the club, in that each member ends up with a working and useful QRP item and the activity involves several members.

Have a Saturday antenna party for a ham who needs a wire in the air. Newer hams are especially susceptible to running into problems that are hard for them to solve, but old hat to one of the old timers. Antenna installations are particularly likely to require some ingenuity in getting a wire high up in a tree or fitting an antenna into an unusual space. And, the more minds available to solve the problem, the better off you are. Alternatively, you might consider a mobile antenna tune-up clinic. After all, not everyone has access to an antenna analyzer. In fact, the club might even buy this instrument, and then make it

available as a part of the clinic.

Another idea might be a Saturday expedition into an uncommon county. Put this QTH on the air, make some county hunters happy and spread the QRP gospel at the same time. The same idea holds, of course, for islands (i.e., IOTA) or special events. You might learn to like the idea of being on the other side of a pile-up.

Plan a QRP presentation for the local DX club or a hamfest. Some hams never become interested in low power because of the belief that at least 100 watts of power is needed to compete on today's crowded bands.

Individual club members could also host a winter meeting at their QTH. Think about having the chance to show off your very own super station to someone who would really appreciate it. Potluck anyone?

Part of the success common to successful clubs is attracting new blood and having a varied agenda of activities. Not everyone is interested in contests, burning solder, ragchewing, or digital modes. But, a winter of meetings has the potential to provide a variety activities and presentations where something will interest just about everyone.

Clubs

Not every club has a website. In each column I'll try to introduce new clubs, and clubs without a web presence. This month is the Cascade QRP Club.

Celebrating their fourth anniversary in November, the Cascade QRPers meet in Tigard, Oregon on the second Saturday of each month. Drawing from the Vancouver, Washington and Portland metro area, meetings usually have 15 hams in attendance. No dues or charter, the club meets for brunch, 9 A.M. at the Old Country Buffet on Highway 99. Homebrew and kit building are popular interests. The club has a mailing list on Topicana at cascadeqrp@topica.com.

If you would be interested in having your club profiled in this column, drop me a line at kl7ixi@attbi.com, or via snail mail at 2162 NE Kevos Pond Dr., Poulsbo, WA 98370. Send along some pictures or other artifacts of your activities. ●●

Floyd Smithberg—NQ7X Contester of the Quarter

Randy Foltz—K7TQ

rfoltz@turbonet.com

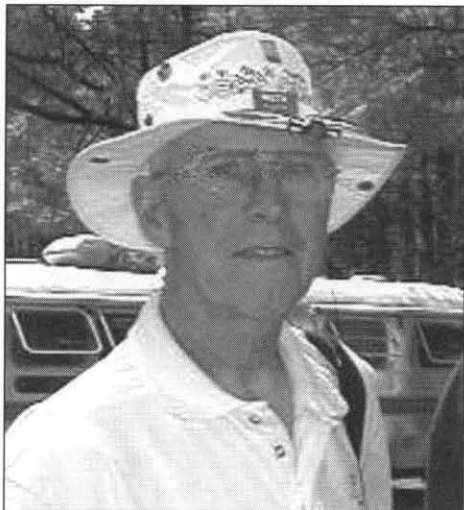

Floyd Smithberg, NQ7X—January QO's Contester of the Quarter.

This issue's Contest Operator of the Quarter is Floyd Smithberg, NQ7X. Some contest operators are like marathon runners. They excel at staying in there and lasting the entire duration of the contest. Others are like sprinters. They put in a limited time, but make the best of that time. NQ7X is one of the best at putting a limited amount of time to the best use. I first noticed NQ7X in the QRP-L Fox Hunts. His strong signal and those heavy weighted dahs were just too distinctive to miss. If you take a look at either the Spring or Fall QSO Parties, you'll find Floyd in the top 10. If you dig a bit deeper you'll notice that he makes those high scores in about half the operating time that the other top operators do. I'll give you two examples. In the 2001 Spring QSO Party he was 9th in 9 hours while the other top ten averaged 18 hours. The 2001 Fall QSO Party results found him in 8th place in just 11 hours. The average operating time of the 1st through 7th place finishers was over 20 hours. Floyd has found that unique skill that enables him to make the very most of his time on the air. Let's see if we can get a few pointers from him.

K7TQ: Before we attempt to learn your secrets, let's find out a little more about you, Floyd.

NQ7X: I live in Sun City West, Arizona and have been a ham for more than 60 years. Until the last five or six years I didn't operate QRP. As Brian, K7RE, told you in the July issue we both decided to try QRP contesting, not expecting any really outstanding results. Both of us were amazed with our results from QRP contesting when we first actually tried it. We began with QRP only events, and worked our way up to the big international contests, entering in the QRP class. Now my contesting is limited to QRP ones or those that have a QRP category.

K7TQ: I've looked at your contest submissions and see that you use a Kenwood TS850 and a triband beam with a 40 m extender.

NQ7X: Right, but although I use the TS850 for contesting, I've built and used most of the NORCAL, SW, and Emtech rigs. I also have an Elecraft K1 in my old '89 Honda hatch back and have a 4 band module waiting to be built. I've made a few contest QSOs mobile with the K1. The beam is a HyGain Explorer with the 40 m extender. It is up about 43 feet on a crank up tilt over tower. Some other equipment that I use is a homebrew variable SCAF filter that does a super job of slicing off high side QRM. Another part of my standard setup is a CMOS III keyer and a Schurr paddle for fills.

K7TQ: A CMOS III keyer...I guess you don't use a logging program.

NQ7X: I have been using TR Log since I started QRP contesting with an HP200. The HP200 is a small palm top PC that runs MSDOS 6.2. It will run for weeks on just 2 AA cells. It is really a QRP

contest PC! I have a TR Log life membership and now use it on my old IBM 486 computer that is dedicated to contesting with DOS only on it. I'm too old now, 83, to change my ways and have to get used to another program.

K7TQ: I use TR Log also and really appreciate it. Do you have any suggestions for using it during a contest?

NQ7X: I try to spend some time with the TR contest simulator at 30+ wpm at rates of 70 to 100 Qs per hour. This helps to sharpen the CW skills before the contest. During the contest I set the code speed at 23 or 26 wpm and get very few requests for repeats from anyone. I'll drop down to 20 wpm or below late in the test to pick up a few slower operators. I should mention that I use a higher keyer weighting, as it produces a distinctive sound that is more easily picked out of a pile up. I am told by operators that they can always spot me in a pileup by that distinctive keying. It



The antenna "farm" at NQ7X.

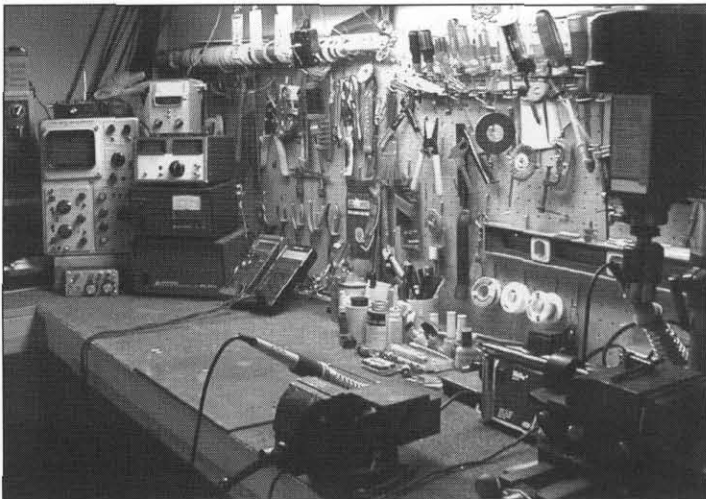

NQ7X's well-appointed workshop.

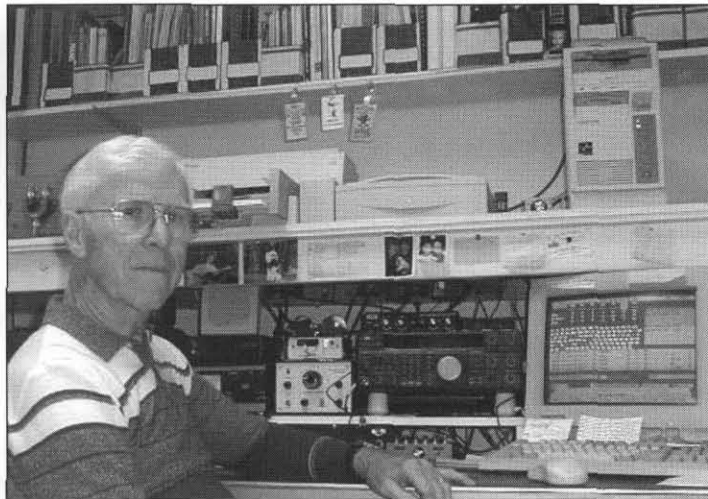

Visualize this layout when you work Floyd in the next contest!

has sort of become my trade mark. Also when I don't connect on the first call when S&P, I'll put the complete received exchange in the exchange window and drop my call once again with the CMOS III, repeating this until I get him or give up. I then only have to hit <Enter> to complete the Q. If you're having trouble copying some of the speed wizards this procedure will help.

K7TQ: Let's review a bit here. Jim, N0UR, in the April issue said he split his time in QRP contest 75% to CQ and 25% to S&P. Brian, K7RE, in the July issue said he did S&P more than most other top operators. What are your ideas on S&P, Floyd?

NQ7X: I do about 60% S&P in QRP contests and about 90% S&P in the QRO contests I enter. As my operating time is quite precious, I try to make every minute count.

K7TQ: When you are CQing and the rate starts to fall, what do you do to get it back up again?

NQ7X: I will try S&P. If this doesn't produce, I change bands. I prefer CQ when the rate is good, for example 25 Qs per hour or more. Also I try to work a different area. It is sometimes difficult working through the east coast to Europe from here in the western US, so I'll try working South America, the Carribean, or the Pacific at those times.

K7TQ: Brian, K7RE, said one of these tricks was to keep the dial constantly moving while S&P'ing. What can you add to this?

NQ7X: I always keep moving. Three or four calls and I'm outa here! Never waste time on a big pile up. Make a few

calls and then move on. You can come back if it is a multiplier you need. They will most likely still be there. Jotting down the needed station with the time and frequency is a help if you don't use a rig with digital memories. Quite often in the big contests, a rare multiplier will be looking hard for QSO's toward the end of the event. That is the time to pounce and nail that rare station. Of course, it all depends on propagation as well. It is possible to completely miss that station by waiting for a better time, too. Many times though, the rare stations are one that have been set up just for the contest, so they will have a good signal and will be on for the entire event.

K7TQ: Do you time your operating during a contest to when you think the most operators will be on?

NQ7X: Nope, my circumstances dictate when I can get on and it frequently isn't the best propagation or activity time. I can only operate when I'm NOT doing my caregiving duties which eliminates 1500-1900Z and 2330-0400Z for me.

K7TQ: That certainly does limit your contesting opportunities. Both of those time slots seem to me to be productive. Tell us which contests you enjoy the most.

NQ7X: I particularly enjoy the DX SSB contests. It seems more personal and fun recognizing countries by their accents.

K7TQ: I heard that you were an accomplished DX operator.

NQ7X: In my 60+ years of operating I have worked approximately 320 countries. These were mostly at well above QRP levels (1 kW). About 309 of them are confirmed, but I no longer chase QSLs. On

satellite I've worked 103 countries on AO10 and AO13, but have few QSLs for those contacts. At QRP levels in the last 5 or so years I've worked 180 countries on CW and SSB, but not all of those are confirmed either. I'm no longer a QSL chaser, as you can tell but I do QSL any direct cards. I know what I have worked, and as my time is precious these days, I have the self satisfaction of those accomplishments.

K7TQ: Floyd, to summarize I'd say that you accomplish those high scores by using about the same set of tricks that the other top operators use. These are constantly moving and searching for new contacts, not wasting time trying to break a pile up, ability to copy CW well at 25 wpm, and knowing when to change operating methods. You certainly do it as well as anyone I know. Your ability to make so many contacts in such a short time is an inspiration. Thanks for the discussion

NQ7X: Thanks for the opportunity. Sorry I can't offer any surefire, magical tricks...just get on the air and listen, listen, listen. Hope to hear you all on the air often.

This is the last version of Contest Operator of the Quarter that I will author. We've talked to Jim, N0UR, Brian, K7RE, Cam, HP1AC, and now Floyd, NQ7X. I know that you've become better acquainted with each of them. I also hope you've picked up a contest hint or two along the way. Next time you work one of these guys in a contest, take a moment to say good afternoon to them and wish them well in the 'test. See you in the next contest.

—Randy B. Foltz, K7TQ

●●

Adventures in Milliwatting—QRPP International

Jim Hale—KJ5TF

kj5tf@madisoncounty.net

Milliwatting has become more popular among QRPers in recent years. Kits, contests, and awards that highlight extreme low power communication seem to be gaining in overall popularity. And the newest ham mode, PSK31 is “forcing” even QRO hams to lower their power.

One of the most popular QRP organizations on the Internet is QRP-L, and many ARCI members are also current or past members of QRP-L.

Now on the Internet comes a new E-list, organization, and webpage called QRPP International. The home page is located at the following URL address: <http://www.qrpp-i.com/>

When you visit the QRPP I homepage there is a link to subscribe to the e-list with a few clicks. It's very easy to do. So far the postings on the QRPP I list have been very good, and on topic. There is only a fraction of the traffic you see on QRP-L, and no controversy. Hopefully, QRPP International will draw new members from the general ham ranks, and more long time QRP'ers and milliwatt operators. Membership is free, but donations are welcome.

The QRPP International webpage is very new, but webmaster Brice D. Hornback, KA8MAV has put together a really professional looking site. The first thing you will see is the following introduction:

“Welcome to QRPP International!

QRPP International is a club for amateur radio operators around the world to share their experience and knowledge as well as help others learn about the lowest power (less than 1 watt) and most fun aspect of amateur radio. We currently have 143 members around the world with more joining every day.” (As of 11/15/01.)

We all love building kits, and on the main QRPP International page you learn about a new kit called the “Tiny Tornado” transceiver. The Tiny Tornado is a modified Pixie type circuit with parts for 40M or 80M. At the moment its “sold out,” but I suspect that new runs will come in time. From the pictures on the site I'd say it and a 9 V battery could fit inside an Altoids tin with lots of room to spare.

On the “QRPP Radios” page there are

links about this kit, and many other links to various pages on the Pixie transceiver. Also the KnightLites “KnightSMite” kit, and NorCal's SMK-1 kit. Both are sold out, but there is some great information on mods for these kits if you are lucky enough to have one, or if you are able to get your hands on one. The schematic diagrams are available and these kits are not hard to build using “dead bug,” “ugly,” or “ugly dead bug” style construction—Hi!

There are links for information on the NorCal 38 Special, NorCal 49er, Tixie, DWM Peanut Whistle Two, Tuna Tin 2, Atlanticon “Snap” transceiver, Foxx-3 transceiver, the Micromountaineer, Jersey Fireball, SW Labs, and others.

In another section of the QRPP International webpage you'll find “QRPP Projects.” Two projects caught my eye right away. If you have a rock bound simple transmitter or DC receiver, how about the “PTO” VFO Kit from WA6OTP?

The next project came from the NorCal QRPP newsletter, and written by John N3AAZ. This one is the perfect L network, tuner for the backpacker. There is no feed-line to mess with, and will tune a 100ft wire for 80 to 10M.

The “QRPP Links” page is loaded with many good things. Too many to try and review here, so you'll just have to see it to appreciate it.

There are some other sections like “Product Reviews,” and the “QRPP Museum.” Not much there now, but the group is pretty new. I'd love to see everyone send in pictures of QRPP radios for the Museum. There must be some of the W1FB projects still around that can be photographed and added to the Museum

page. Long live the Pebble Crusher! And I'm sure there are others that should be included there as well.

ARRL approves QRP DXCC award

The December QST has arrived here and we see the article in there about the new QRP DXCC award. This is a welcome change, and overall it looks to be set up pretty well. Some may feel that because QSL cards don't need to be sent to ARRL for proof, that the award is inferior to the regular DXCC. I don't see this as a big problem. After all, this is a hobby, and if someone wants to cheat they are only hurting themselves. The reason we do this is because it's fun. If someone wants to bypasses the fun to get some wallpaper, they are the ones who lose.

Someone commented on QRP-L that with 5 watts, a person could just about earn the QRP DXCC in a weekend during one of the major CW DX contests. This is exactly correct. Or if they chose to take it easy, in only a year's time they could earn the QRP DXCC.

Right now I know of a handful of QRP operators who are already working on DXCC with less than 1 watt. This started as a personal challenge. They took this upon themselves in pursuit of only the FUN, because at that time no award existed. However, recently QRP ARCI has made a milliwatt endorsement available to their existing QRP DXCC, and QRP WAS award.

As more and more hams undertake the 5w QRP DXCC, I wonder how many will go on from there and go after the “ultimate” challenge of DXCC using less than 1 watt? ●●

***Don't Miss an Issue of QQ —
Keep Your QRP ARCI Membership Up-To-Date !***

***Check the mailing label on this issue,
then go to www.qrparci.org and renew online.***

***Use the convenient PayPal option
for credit card payments.***

QRP Contests

Randy Foltz—K7TQ

rfoltz@turbonet.com

Greetings fellow QRP contest operators. This issue of QRP Contests contains the results from the Summer Daze SSB Sprint, the End of Summer PSK-31 Sprint, and the Fall QSO Party. There are also announcements for the Winter Fireside SSB Sprint, the Spring QSO Party, and the Hoot Owl Sprint. If you'd like to see the scores of any QRP ARCI contest in 2000 or 2001 sorted by score take a look at: <http://personal.palouse.net/rfoltz/arci/past.htm>

After each contest you can use the High Claimed Scores form at: <http://personal.palouse.net/rfoltz/arci/form.htm> to send me your contest summary. Your log can be sent separately by either email or regular mail. Watch the claimed scores change nightly at 9 PM Pacific Time for 2 weeks after the contest by looking at <http://personal.palouse.net/rfoltz/high-claim.htm>. This web page contains only those results submitted by using the web page form above.

On to the results!

Summer Daze SSB Sprint

The Summer Daze SSB Sprint for 2001 was held on August 5. Participation was down as it has been for the last several years. The mid-summer date does not appear to be a good one because of other activities. The mid-winter SSB contest does a better job of drawing participants. The Summer Daze SSB Sprint will, therefore, be given a rest for 2002. Thanks to all who have participated over the years.

Soapbox

K0RDS—Did not get the chance to work

Mark your Calendars:

Fireside SSB Sprint <i>Feb 10, 2002</i>	Spring QSO Party <i>April 13 & 14, 2002</i>	Hoot Owl Sprint <i>May 26, 2002</i>
---	---	---

many. Band conditions bad here. **K2WY**—Bands very weak. My first contest. **KG7TG**—First contest with FT817; first contest for which I've submitted a score. **WA9TZE**—Due to "M" flare, lost 20 M for 25 minutes. Checked the other bands but little activity for the ARCI con-

Summer Daze SSB Sprint Top Three:	
N9NE	43,078
WA9TZE	34,125
KG4CHX	27,120

test, so stayed on 20 M. 60 Qs in 4 hours is lots of work, but enjoyable. **N9NE**—First-hour Qs on 10 meters with 'Ten-Tenners' and a last-minute run on 75 meters with non-contester Midwesterners resulted in a large number of 'unique' QSOs (really, honest!!) **KG4CHX**—Worked as much DX as state side. Terrible on 40 meters never heard anyone. Never heard anyone on 80 either! DX was great on 20!!

End of Summer PSK-31 Sprint

The 2001 version of the End of Summer PSK-31 Sprint was held on September 9. This was the second year we've had this sprint and interest seemed to be down from the first event. Perhaps this was due to more PSK-31 operating events, an erosion of the novelty of the mode, or

the fact that many PSK-31 folks want to have an extended QSO rather than a short quick contest exchange. Soapbox comments in both this year's and last year's contest have reflected this preference. On the plus side there are comments that new states or countries have been worked during the contest. The 2002 sprint is scheduled for September 8. We'll revisit whether this contest will continue after the 2002 event.

Soapbox

K4AGT—This contest proved the viability of QRP, but I would rather use PSK-31 for ragchewing than contests. **N9WW**—Local rainstorm limited operating time and

End of Summer PSK-31 Sprint Top Three:	
N3FX	31,164
W4JHR	15,876
NN9K	15,260

QSB resulted in a few missed QSOs. A fun afternoon, though. Thanks! **W3HF**—Could only operate for the last hour or so, due to family commitments, but still had a great time. Maybe next year I'll be on for longer. **N0HRL**—I enjoyed my casual effort in this fun little sprint. Lots of signals rather crowded together, with a lot of non-contest stations mixed in.

Summer Daze SSB Sprint 2001									
QTH	Call	Score	Pts	SPC	Power	Bands	Time	Rig	Antenna
CA	WK6I	4,914	54	13	LT10		4	K2	C3SS @ 30'
	NK6A	1,638	39	6	LT10	20	1.5	K2	C4
NC	KG4CHX	27,120	113	24	LT2	20,10,15	4	K2	Tribander @ 55'
NY	K2WY	945	27	5	LT10	20,15,10	1	Scout 555	
TX	K0RDS	357	17	3	LT10	20	0.25	SG2020	20 m delta loop
WI	N9NE	43,078	181	34	LT10	80,40,20,15,10	4	K2	80 m zepp, tribander
	WA9TZE	34,125	195	25	LT10	20	4	TS870S	EX-14
	NK9G	805	23	5	LT10	40,20,10	1	FT817	R7
WY	KG7TG	476	17	4	LT10	20	3	FT817	DX-EE

End of Summer PSK-31 Sprint 2001

QTH	Call	Score	QSO Pts	SPC	Power	Time	Rig	Antenna
AL	K4AGT	3,150	50	9	LT5	2	TS830S	GAP Titan DX
CA	WK6I	4,914	54	13	LT5	2		
	W6ZZZ	560	20	4	LT5	4	IC756pro	HB 80/20 m fan dipole @ 25'
CO	N0LX	9,240	88	15	LT5	3.8	Alinco DX-70	10-80 m window
	N0IBT	2,457	39	9	LT5	3	TS870	Dipole
FL	N1ZZZ/4	704	64	11	GT5	2.3	TC746	Apartment zepp @ 30'
	K4FS	560	20	4	LT5	2		
GA	W4JHR	15,876	108	21	LT5	4	K2	80 m dipole
HP	HP1AC	4,158	54	11	LT5	3	IC706	TA33 jr
ID	N6YIH/7	1,470	35	6	LT5	4	TT Paragon	Dipole
IL	NN9K	15,260	109	20	LT5	4	TT Pegasus	C3 @ 45'
	N9MZP	13,083	89	21	LT5	4	TS450	G5RV
	N9WW	1,218	29	6	LT5	2	SWL PSK-20	Inv vee @ 40'
KY	AG4CZ	13,699	103	19	LT5	4	TS570	1/4 wave vert
	KD9B	1,302	31	6	LT5	3	IC706	G5RV @ 20'
MD	N3FX	31,164	159	28	LT5	4	FT920	Triband yagi @ 65'
MN	N0UR	14,000	100	20	LT5	4	FT920	3 el yagi
	N0HRL	1,960	35	8	LT5	2	FT817	Attic dipole
NM	K5AM	3,500	50	10	LT5	1	HB transceiver	Tribander
PA	WB5NHL	2,912	52	8	LT5	4	SWL PSK-20	Indoor Isoloop
	W3HF	1,960	40	7	LT5	1.2	SWL PSK-20	Attic dipole
UT	K7RJ	805	23	5	LT5	2		
VA	KU4FP	3,311	43	11	LT5	4	TS440S	Carolina window

WB5NHL—How can you beat lots of QRP PSK and country #46 to boot. Normally, a listen and pounce operator but first time calling CQ and getting a call.

N6YIH/7—Had a ball. Did not know this radio would work at 5 watts. Had to turn everything all the way down to get 4 watts output. I will be back again for the next one. THANKS. **N1ZZZ/4**—Funny being a “big gun” at 30 W, hihi. Doing pretty well with an apartment dipole. Fun contest.

N3FX—A fun contest! Propagation only fair, but good enough. The number of PSK testers is growing, but not as fast as I’ve expected. **K7RJ**—Thanks for the new state, number 48 for me on 20 meter PSK-31 QRP with my PSK-20! All I need on 20 is AK and, of all things, VT. What a great thing to see so many people show up.

Fall QSO Party

The Fall QSO Party for 2001 was held September 29 and 30. When I scheduled it back in November 2000, it appeared to me to be a good weekend. The conflict with Pacificon was avoided as well as any with the major state QSO parties. WHOOPS! What I didn’t find was the CQWW RTTY contest was the same weekend. As those of you that participated found out, 40 M RTTY operations made for a difficult time.

For 2002 I’ve moved the contest back to its traditional third weekend in October. It looks to me like there will be no major on-the-air conflicts. Only Pacificon will conflict with the 2002 Fall QSO Party. Life is full of choices.

The Fall QSO Party and the Spring QSO Party are the two big events on the ARCI calendar. I’ve often wondered how many hams take part in these two events.

Fall QSO Party—Top 10	
N4BP	2,300,400
K0FRP	1,669,800
K7RE	1,612,261
N0UR	1,527,360
NC7W	1,313,053
N9NE	1,166,375
K7TQ	1,100,386
NQ7X	776,454
WA4DOU	764,946
W4DEC	739,431

The listings in this issue for the Fall QSO Party have 94 folks that sent in logs. Of course, nowhere near every one sends in a report. This year I took eight of the top ten logs, because they were electronic, and found that there were 620 unique calls in those reports. It seems safe to say that 650 to 700 hams made at least one Fall QSO

Party contact.

The top ten once again has several familiar calls. In his usual spot at the top was Bob, N4BP, holding forth from Florida with a mighty 900 mW signal. Al, K0FRP, and Brian, K7RE, ran a close race for second. K7RE had more QSO points as well as more multipliers, but K0FRP made up for it with the less than 1 W power multiplier. You will undoubtedly recall that Brian was the Contest Operator of the Quarter in the July issue. The Contest Operator of the Quarter from the January issue, Jim, N0UR, was fourth. While on the topic of Contest Operators of the Quarter, take a look at NQ7X in eighth place. Floyd is this issue’s Contest Operator of the Quarter. What is really remarkable about his score is that he did it in 11 hours, about 1/2 the number of the other top 10 finishers!

The box containing the Category Winners deserves a comment or two. Take a look at K9PX in the 40 M band only category. Jim has a respectable score of 213,528 points in 11.5 hours of operation on 40 M. Rather than complain about the RTTY contest, Jim got on the air and operated! A tip of the contest manager’s hat to you Jim. You will receive a very well deserved certificate for your efforts.

FALL QSO PARTY 2001

QTH	Call	Score	Pts	SPC	Power	Bands	Time	Rig	Antenna
AL	W4DEC	739,431	1067	99	LT5	160,80,40,20,15,10	18	K2	A4S @ 70'
	K4AGT	7,644	84	13	LT5	20	2	OHR-100	GAP Titan DX
AZ	K7RE	1,612,261	1657	139	LT5	40,20,15,10	24	K2	TA33
	NQ7X	776,454	973	114	LT5	40,20,15,10	11	TS850S	3 el yagi w/ 40 m extender
	N7CEE	616	22	4	LT5	20,15,10	1	K2	HB Vert
BC	VE7BLU	4,550	65	7	LT1	20,15,10	3	K2	80 m zepp
CA	NK6A	237,153	491	69	LT5	40,20,15,10	4	K2	C4 @ 40'
	AD6GI	149,765	389	55	LT5	40,20,15,10	14	K2	40m short dipole, dipoles
	W4NJK	47,586	309	22	LT5	40,20,15,10	5.6	IC781	40 half square
CO	K0FRP	1,669,800	1380	121	LT1	80,40,20,15,10	18.5	TS850	Tall yagis
	N0TK	461,622	758	87	LT5	40,20,15,10	15	K1, NC20, HTX-100	Attic dipoles
	N0RC	51,744	224	33	LT5	15,10	5	TS570D	Attic antenna
	W9KV	9,100	100	13	LT5	20	1.6	Norcal 20	Multi-band dipole
CT	K1SWL	156,156	429	52	LT5	80,40,20,15,10	12	FT840	Dipoles @ 40'
	N1EI	141,270	277	34	LT250	80,40,20,15	11	OHR500	80 m doublet @ 50'
	W1VT	136,150	389	50	LT5	20,15	3.5	K2	C3S
FL	N4BP	2,300,400	1620	142	LT1	160,80,40,20,15,10	24	K2	TH7, 402BA, dipoles
	W4FMS	692,265	1041	95	LT5	160,80,40,20,15,10	7	K2	A4S @ 40'
	K4FS	41,006	202	29	LT5	40,20,15,10	11		
G	G3XJS	1,470	35	6	LT5	15,10	1.5	K2	DX32
GA	AF4PP	190,414	469	58	LT5	80,40,20,15,10	14	K2	44' doublet @ 50'
	KE2WB	162,309	393	59	LT5	80,40,20,15,10	8	HW9	131' dipole @ 40'
	K4GT	8,295	79	15	LT5	20,15	1	K2	C3S
IA	KB0JUL	149,380	388	55	LT5	40,20,15	8	Argonaut 509	Dipoles & Inv vee
	W0PWE	147,600	410	36	LT1	20	7.25	Mahattan built SST20	Open sleeve dipole @ 45'
ID	K7TQ	1,100,386	1483	106	LT5	40,20,15,10	24	K2	C4S @ 50'
	W7CNL	94,164	354	38	LT5	10	11	Argosy	TA33 @ 42'
IL	N9WW	36,540	174	30	LT5	40,20,15,10	5	FT301SD, K1	Multi-band dipole @ 35'
	N9RY	14,497	109	19	LT5	20	2.5	K1	Inv vee in attic
	W9CUN	3,710	53	10	LT5	80	1.5	TT Delta 580	40 m horiz loop @ 8'
IN	K9PX	213,528	744	41	LT5	40	11.5	K2	80 m loop
	KA8MAV	35	5	1	LT5	40	0.3	HW8	Hamstick
KY	K4AT	218,624	488	64	LT5	40,20,15,10	8.3	TS870	40 m dipole, R7
MD	K3CHP	465,080	755	88	LT5	80,40,20,15,10	23	FT817	Vert & 3 el yagi
	W3ERU	396,634	691	82	LT5	80,40,20,15,10	18	TS850SAT	40 m loop & triband beam
	W3MWY	37,632	192	28	LT5	40,20,15	6	Argo 556	23' vert wire @ 60'
	K4JSI	32,396	178	26	LT5	40,15,10	4	QRP+	30' Al foil doublet in attic
	WA3GYW	9,345	89	15	LT5	80,40,20,15	1.5	HW8	130' long wire @ 20'
ME	K0ZK	214,305	471	65	LT5	40,20,15,10	10	K2	20 m dipole
	W1QHG	62,930	290	31	LT5	20	3.5	K1	Carolina windom
MI	KA1DDB	386,463	717	77	LT5	80,40,20,15,10	18	Sierra	G5RV @ 35'
	K8AAX	148,554	393	54	LT5	80,40,20,15,10	5.25	QRP+	Carolina windom
	AB8DF	9,240	88	15	LT5	40,20,15,10	3		
MN	N0UR	1,527,360	1376	111	LT1	160,80,40,20,15,10	22	K2, FT920	Wire yagis
	K0SQ	504,861	829	87	LT5	160,80,40,20,15,10	12.3		
	K0PC	355,740	660	77	LT5	40,20,15,10	6	K2	Tribander @ 40'
	W0UFO	257,075	565	65	LT5	40,20,15	12.75	NC20, NC40, MS15	Dipoles, Zepp
	N0HRL	3,150	50	9	LT5	40,20	2	K1	Attic dipole
MO	K0LWV	123,032	338	52	LT5	80,40,20,15,10	6	TS520	CF Zepp @ 20'
	KCOM	56,525	95	85	LT5	80,40,20,15,10	17		
	WA0OTV	1,204	86	14	GT5	15	2	TS530S	Indoor wet noodle
NC	WA4DOU	764,946	934	117	LT5	80,40,20,15,10	15.75	FT990	C3SS & Inv vee @ 40'

QTH	Call	Score	Pts	SPC	Power	Bands	Time	Rig	Antenna
NH	W1PID	9,408	96	14	LT5	80,40,20,15,10	2	FT817	OCF dipole
NJ	W2AGN	537,420	689	78	LT1		19	HW8, Argo 515	KT34A, 40m dipole, 300' hor. loop
	N2CQ	402,960	552	73	LT1	80,40,20,15,10	7	TS850sat	TA33jr & CF Zepp
	K2JT	195,000	375	52	LT1	160,80,40,20,15,10		Sierra	Doublet
	K2T	195,000	375	52	LT1			Sierra	Doublet
	W2JEK	148,029	371	57	LT5	160,80,40,20,15,10	5	FT840	Dipole, gnd plane, end fed
NY	K2QO	67,830	255	38	LT5	80,40,20,15,10	7	Omni 6+	140' loop & HF2V
	W2QYA	23,400	117	20	LT1	40,20,15	8	HW-8	Inv vee
	N2JNZ	5,700	57	10	LT1	20,15,10	6	Argo 509	AR-10 & DXEE
OH	W8VE	150,535	391	55	LT5	80,40,20,15,10	8	TR7	C4S
	WB8ZWW	114,380	301	38	LT1	20,15,10	9.5	Sierra	Carolina windom
	K8UPR	57,190	215	38	LT5	40,20,15,10	8	FT817	R8
	N8ET	34,104	168	29	LT5	40,20,15,10	2		
	AB8FJ	34,104	168	29	LT5	80,40,20,15,10	4.5	Argonaut II	Random wire
	K8CZ	9,744	87	16	LT5	40	4	FT757GX	HF6V
OK	K5OI	32,032	176	26	LT5	80,40,20,15,10	6	K2	Random wire
OR	N7OU	584,640	928	90	LT5	40,20,15,10	7	K2	Wire beams
PA	WB3AAL	658,560	784	84	LT1	80,40,20,15,10	15.5	K2	HF9V
	K3WW	512,190	813	90	LT5	80,40,20,15,10	15	K2	C3, Skyhawk, 402CD, 80m vert
	W3BBO	457,968	752	87	LT5	80,40,20,15,10	14	K2	Verticals
	N3AO	325,822	629	74	LT5	80,40,20,15,10	8.5	K2	Yagi & inv vee
	NA3V	187,922	433	62	LT5	80,40,20,15,10	7	IC756	130' doublet @ 65'
	KW3U	96,278	299	46	LT5	80,40,20,15,10	11	FT920	R7 & long wire
	K3HX	56,826	369	22	LT5	40	8.75	TS870	40 m dipole @ 42'
	N3CZB	168	12	2	LT5	20	3	MFJ9020	
TN	NU4B	285,936	552	74	LT5	40,20,15,10			
	KW4JS	103,635	315	47	LT5	80,40,20,15,10	11	K2	Multi band loops & vert
TX	W5USJ	235,690	481	70	LT5	40,20,15,10	9		
	K5QLF	2	2	1	GT5	20	0.03	K1	Doublet
UT	NC7W	1,313,053	1477	127	LT5	80,40,20,15,10	23		80m loop
VA	K3SS	210,665	463	65	LT5	80,40,20,15,10	10	FT757GX	Inv vee @ 35'
	N4UY	111,800	260	43	LT1	40,20,15,10	9	Argosy	Wire dipoles
	KG4LDY	6,006	66	13	LT5	80,40,20,15	2	TT Jupiter	DXCC @ 20'
WA	N0AX	512,940	618	83	LT1	160,80,40,20,15,10	9		
	K7ED	65,520	234	40	LT5	20,15,10	7		
	KX7L	43,680	195	32	LT5	80,40,20,15,10	5	IC735, 2N2/40	Inv el & delta loop
	N7RVD	21,735	135	23	LT5	20,15,10	1.25		
WI	N9NE	1,166,375	1333	125	LT5	80,40,20,15,10	22.5	K2	80 m CFZ & Tribander
WV	WA8WV	98,518	454	31	LT5	40	9.5	FT1000MP MKV	EF240 @ 40'
	K8KFJ	36,260	185	28	LT5	40,20	4	IC706MKII	14AVQ
DX	HP1AC	357,595	601	85	LT5	20,15,10		IC706MKIIG	TA33jr
DX	PA9RZ	35	5	1	LT5	10	1	FT817	GAP

Category Winners

Less than 250 mW	N1EI	141,270
10 M band only	W7CNL	94,164
15 M band only	WA0OTV	1,204
20 M band only	W0PWE	147,600
40 M band only	K9PX	213,528
80 M band only	W9CUN	3,710
20, 15, 10 M bands only	HP1AC	357,595

Teams

Aluminum Kings	
N4BP, K0FRP, K7RE, N0UR, N8ET:	7,143,925
NJQRPeaNuts Team	
N2CQ, N2CX, W3BBO, W2AGN, AA1MY:	1,398,348
Eastern PA QRP Team	
N3AO, WB3AAL:	984,382
Watt Me Worry?	
N0AX, K7SS, N7ED, NX7L:	556,620

Soapbox

AD6GI—Great time! Highest score I have achieved; revealed numerous things I need to change before the next contest and will need to start this right now. **AF4PP**—Good conditions and fantastic operators made for a very fun weekend. The beautiful Fall weather enabled a 100% backyard effort. **G3XJS**—HF conditions were about the worst I can remember for an ARCI contest, with signals being VERY weak and watery. **K0FRP**—Good to see 10/15m doing well, 40m RTTY was rough. Had fun. **K0LWV**—Plenty of RTTY QRM. **K0PC**—Good conditions and turn out for this contest. Lots of fun but I only had 6 hours to put in it. **K1SWL**—Good conditions! **K2JT**—A dozen QSOs in the last hour sure helped. **K2QO**—I did not have much time to play but conditions seemed really good, except for the RTTY QRM on 40. **K2T**—Results better than expected, thought the RTTY contest would create more QRM, only 40 M at night affected. **K3CHP**—Heavy digital pollution on 40 meters. **K3HX**—Are RTTY people deaf? Was repeatedly QRMed by 20 over RTTY signals. **K3SS**—Missed our Canadian friends. Only worked two VE3s and one VE5. **K3WW**—Still seemed a bit slow, so worked the RTTY Contest simultaneously quite a bit of the time. **K4AT**—It was lots of fun at times but the RTTY contest in the CW subband was trying at times. **K4JSI**—Hope next year's event won't be opposite a major contest. Glad to see 10 M open! Looking forward to next year. **K5OI**—Had lots going on this weekend but did get in some time. Enjoyed talking to many old friends. **K7ED** (WA0RJY, op)—Great fun! **K7RE**—I worked for 23 hours and 58 minutes. 10 and 15 M were just great. I worked Cam HP1AC on 20 and 10M, as well as ZP6BX (Paraguay), yes they were both QRP. **K8CZ**—Had a great time in my first ARCI contest in spite of the restriction on operating time and QRM from the RTTY Contest. Better luck next time, see you all then. **K8KFJ**—Very limited operating time but had fun giving out WV mults. **K9PX**—Nice to hear so many guys braving the 40 M RTTY. QRM again!! **KA1DDB**—I had a great time, thanks! **KB0JUL**—I look forward to the QSO parties each year. 15 and 20 M were great from Iowa. 40 M had too much QRM from digital stations. **KC0M**—This was a great contest, I got to play with a new beam and

logging program. **KG4LDY**—Very impressed by quality of operators. Very clean CW fast enough but not too fast to copy. **KW3U**—Lots of quality ops out there, only wish I could have worked 24 hours. **KX7L**—My first somewhat serious attempt at this contest. It was good fun, but a K index bouncing from 3 to 5 made it a little rough. Hope to try again next year. **N0AX**—This year, I turned it down to just 1W instead of 5 for the extra power multiplier—turned out well. One of these years, I will get a full-time entry together. **N0HRL**—Didn't have a lot of time, but had fun. Certainly was a good workout for the filters, hunting around all of those RTTY signals. Thanks for another fun event. **N0RC**—Fun time as always. **N0TK**—Lots of familiar call signs. **N1EI**—Bands seemed kind of noisy on Saturday. Better Sunday. **N2JNZ**—Thanks to Bob, N4BP for 3 bands!!! And Cam, HP1AC for a NEW mW country!!!! **N3AO**—Always good to be in this contest. And nice to hear familiar calls as well as new ones. I look forward to the next contest! **N4BP**—Highlights: Coast to coast with K7FD on 40 M, 2xK2 <1W. HP1AC on three bands, JA3ARM on 10 M. Lowlight: RTTY everywhere. **N4UY**—Thanks to those who organized and played in this event—challenging and lots of fun. Held my old Argosy down to 450 milliwatts. Good to find the QRP sigs among the 40 M RTTY. **N7CEE**—I only had an hour to operate, and even that was sporadic due to other obligations. We were about to leave for an overnight camping trip, and I should have taken the rig along! **N7OU**—Good to hear so many familiar calls pounding in. Looking forward to Sweepstakes QRP next month and already plotting my strategy. **N9NE**—Lots of fine 'ears' out there. Several stations were worked on four bands. High point was contacting ZL1TW after midnight on 20 mtrs K2 to K2 with 589 reports. **N9RY**—Good time even with town house antenna restrictions. **N9WW**—Sporadic operating schedule, but I enjoyed every minute and QSO. Thanks, Randy. **NA3V**—Nice buzz of activity on upper bands including 10 M, which helped to make up for the RTTY QRM on 40 M. **NK6A**—Thanks for another fun contest. Could only operate a few hours over the time period. Missed a few good openings on 10 M. **PA9RZ**—Only one station heard and worked. Because of

the beautiful "Indian Summer" like weather I spent more time outdoors than in the shack. **VE7BLU**—Was I the only one using a straight key? **W0PWE**—With the QRM on 40 I decided to stay on 20M and use my Manhattan style SST. **W0UFO**—Too much digital QRM on 40 M, otherwise much fun. **W1PID**—Lots of fun. Thanks. **W1VT**—91 contacts in 3.5 hours. I heard JA6PA calling someone I worked on my run freq—so I moved the beam and worked him! **W2AGN**—Wanted to try without benefit of K2. I definitely missed those filters on 40M!! **W3BBO**—Another fun test. Had to limit my operating time. **W3ERU**—Bands were good. RTTY was a terrible. Worked all bands. 1st time. Good time. **W4DEC**—Band not too good at Theodore, Alabama. **W4NJK**—Great contest with good participation! Odd QSB at times plus QRM from both many participants and RTTY at times. Good fun and skill builder, TNX all for QSOs. **W5USJ**—Nice to have band conditions fairly good across 40 to 10 meters. Didn't get started until Sunday morning but scored as well as I have in previous events. **W7CNL**—The band (10M) had deep fades with signals barely perceptible one minute and good copy a few minutes later. 8P6BX was a new one two way QRP. **W8VE**—This is my first Fall QSO Party. I entered the Running of the Bulls in 2000 CW Sweepstakes and had a great time. I also placed 1st in my section in the ARRL 10 M contest. **WA0OTV**—Just got on for a couple of hours this year and handed out a few points. Had a ball. The 15 M band was wide open. **WA3GYW**—It was a very good contest. **WA4DOU**—Pretty good conditions. Best DX was JA, ZL, and a few Europeans. 80 meters needs more activity. Thanks to all for the QSOs. **WB3AAL**—Fighting the RTTY stations was a challenge. Best DX was EC5CEE on 15 M, EA5AKM on 15 M, HP1AC on 10 & 15 M and KH7T on 10 M. Thanks for all the Qs guys! ●●

**CU in the QRP ARCI
2002 SPRING QSO PARTY!**

**April 13, 1200Z
through
April 14, 2400Z**

2002 Spring QSO Party

CONTEST ANNOUNCEMENTS

2002 Winter Fireside SSB Sprint

Date/Time: February 10, 2002; 2000Z to 2400Z, SSB HF only

Exchange: Members — RS, State/Province/Country, ARCI Number; Non-member — RS, State/Province/Country, Power Output.

QSO Points: Member = 5 points; Non-member, Different Continent = 4 points; Non-member, Same Continent = 2 points.

Multipliers: SPC (State/Province/Country) total for all bands. The same station may be worked on more than one band for QSO points and SPC credit.

Power Multiplier (PEP): Note the higher SSB power limits!

0 - 500 mW = $\times 15$
500 mW - 2 W = $\times 10$
2 W - 10 W = $\times 7$
Over 10 W = $\times 1$

Suggested Frequencies:

80 M 3865 kHz
40 M 7285 kHz
20 M 14285 kHz
15 M 21385 kHz
10 M 28385 kHz

Score: Points (total for all bands) \times SPCs (total for all bands) \times Power Multiplier.

Entry may be All-band, Single-, High-, or Low-Band. Entry includes a copy of logs and summary sheet. Include legible name, call, address, and ARCI number, if any. Entry must be received within 30 days of contest date. Highest power used will determine the power multiplier.

The final decision on all matters concerning the contest rests with the contest manager. Entries are welcome via e-mail to rfoltz@turbonet.com or by mail to

Randy Foltz
809 Leith St.
Moscow, ID 83843

After the contest send your report by visiting: <http://personal.palouse.net/rfoltz/arciform.htm>. Check the web page at <http://personal.palouse.net/rfoltz/arcihighclm.htm> for 2 weeks after the contest to see what others have said and claimed as their scores.

Date/Time: April 13, 2002; 1200Z through April 14 2400Z. You may work a maximum of 24 hours of the 36 hour period. CW only.

Exchange: Members — RST, State/Province/Country, ARCI Number; Non-member — RST, State/Province/Country, Power Output.

QSO Points: Member = 5 points; Non-member, Different Continent = 4 points; Non-member, Same Continent = 2 points.

Multipliers: SPC (State/Province/Country) total for all bands. The same station may be worked on more than one band for QSO points and SPC credit.

Power Multiplier:

0 - 250 mW = $\times 15$
250 mW - 1 W = $\times 10$
1 W - 5 W = $\times 7$
Over 5 W = $\times 1$

Suggested Frequencies:

160 M 1810 kHz
80 M 3560 kHz
40 M 7040 kHz
20 M 14060 kHz
15 M 21060 kHz
10 M 28060 kHz

Teams: You may enter as a team of either 2 to 5 members per team, or unlimited number of operators as long as a maximum of 5 transmitters on the air at a time. You compete individually as well as on the team. Teams need not be in the same location. Team captain must send list of members to Contest Manager before contest.

Score: Points (total for all bands) \times SPCs (total for all bands) \times Power Multiplier.

Entry may be All-band, Single-, High-, or Low-Band. Entry includes a copy of logs and summary sheet. Include legible name, call, address, and ARCI number, if any. Entry must be received within 30 days of contest date. Highest power used will determine the power multiplier.

The final decision on all matters concerning the contest rests with the contest manager. Entries are welcome via e-mail to rfoltz@turbonet.com or by mail to

Randy Foltz
809 Leith St.
Moscow, ID 83843

After the contest send your report by visiting: <http://personal.palouse.net/rfoltz/arciform.htm>. Check the web page at

<http://personal.palouse.net/rfoltz/arcihighclm.htm> for 2 weeks after the contest to see what others have said and claimed as their scores.

2002 Hootowl Sprint

Date/Time: May 26, 2002; 8:00 p.m. to 12:00 p.m. Local Time. CW only.

Exchange: Members — RST, State/Province/Country, ARCI Number; Non-members — RST, State/Province/Country, Power Output.

QSO Points: Member = 5 points; Non-member, Different Continent = 4 points; Non-member, Same Continent = 2 points.

Multipliers: SPC (State/Province/Country) total for all bands. The same station may be worked on more than one band for QSO points and SPC credit.

Power Multiplier:

0 - 250 mW = $\times 15$
250 mW - 1 W = $\times 10$
1 W - 5 W = $\times 7$
Over 5 W = $\times 1$

Suggested Frequencies:

160 M 1810 kHz
80 M 3560 kHz
40 M 7040 kHz
20 M 14060 kHz
15 M 21060 kHz
10 M 28060 kHz

Score: Points (total for all bands) \times SPCs (total for all bands) \times Power Multiplier.

Entry may be All-band, Single-, High-, or Low-Band. Entry includes a copy of logs and summary sheet. Include legible name, call, address, and ARCI number, if any. Entry must be received within 30 days of contest date. Highest power used will determine the power multiplier.

The final decision on all matters concerning the contest rests with the contest manager. Entries are welcome via e-mail to rfoltz@turbonet.com or by mail to

Randy Foltz
809 Leith St.
Moscow, ID 83843

After the contest send your report by visiting: <http://personal.palouse.net/rfoltz/arciform.htm>. Check the web page at <http://personal.palouse.net/rfoltz/arcihighclm.htm> for 2 weeks after the contest to see what others have said and claimed as their scores. ●●

One More Idea to Exchange

Mike Czuhajewski—WA8MCQ

wa8mcq@erols.com

Thoughts on Soldering Technique

George "Danny" Gingell, K3TKS of Silver Spring, MD provided these comments after a discussion at an "Elmer 101" session on whether and how to clean the bare PCB and component leads.

Homemade boards, or professionally made ones that have been sitting around for a long time before use, may have oxidation or full blown corrosion. (They might even have protective coatings.) I prefer to use ScotchBrite™ pads from 3M or a couple of plain red gum erasers. These work nicely on pads or component leads. *[ScotchBrite is available in different colors, each with a different grade of abrasiveness. —WA8MCQ]*

One cleaning method is to secure two of the erasers to a block of wood or the workbench itself, using drywall screws and a couple of small washers. The idea is to be able to easily replace or adjust the erasers. Just place the component lead between the eraser sandwich and apply a little pressure with one finger while rotating and removing the component from the cleaning assembly.

Some leads such as diodes and some capacitors will not withstand much stress. These should be held with flat pliers such as duckbills to prevent stress to the component connection. Most semiconductors fall into this special category also.

As always, anything that is static sensitive needs even further precautions during handling. Anyone working on static sensitive devices should have a proper wrist strap (with a megohm or more in series to ground).

With new components such as those supplied with kits you are not likely to have much need for lead cleaning. Still it is good to know how to deal with the problems of lead corrosion. There are lots of "new old stock" (NOS) components on the flea market scene [old but still unused parts]. I am also sure that I have lots of old stock components in the basement that will need cleaning before use; some that were "new stock" kits several years ago!

I guess the real answer is to use the least abrasive necessary to do the job. Sandpaper or emery paper should only be

used in the most stubborn cases. (RARELY!) The only thing that I ever used sandpaper or emery paper on was enamel coating on magnet wire leads for coils.

Also, anything used to clean corrosion is likely to leave a residue. Someone on QRP-L mentioned cleaning with fine steel wool, which before the invention of ScotchBrite pads was one method of choice for cleaning homemade boards. Bear in mind that most steel wool pads contain a petroleum product coating the steel wool as part of the manufacturing process. Any residue can be cleaned with dishwashing liquid followed by plain water and blow dry. Do not use a hair dryer on boards with components already mounted. The dry air static could kill a perfectly good project. It works fine for bare boards, though.

[Another drawback of using steel wool is that it can leave tiny steel filaments as it catches on sharp edges. These can cause shorts. Be sure to clean carefully after using steel wool and keep an eye out for this. —WA8MCQ]

A lot has been mentioned about component leads and whether to solder first or cut first. I personally have always put the leads thru the holes and bent them at a 45 degree angle and soldered, and then clipped. The scissors type of cutters is preferred, but not really necessary. I have used my old baby telephone dikes (diagonal cutters) for years with perfect results. Someone mentioned the cut-off ends of leads flying away with this method. Yes, they can and is exactly why you should wear safety glasses while doing this type of work. I generally hold the lead to be clipped with my left hand while clipping with my right. I then put the "scrap lead" in the Scrap Lead Box or Tin. They come in handy for jumpers, hole cleaning tools, and a number of other uses around the workbench.

I notice that many also like to have their components up tight against the PCB. I tend to have a different approach. I like mine away from the board for several reasons. That 1/32" inch of space may allow you to attach a test lead probe and it also allows just enough lead length to fit back in easily if the lead is lifted for testing or

repairs. In some cases it is best to clip a lead at the component body and use it's lead for the connection to the replacement part.

There are a few rare cases where the leads must be cut to fit before installing the component, as mentioned by someone else on QRP-L using the Elecraft K2 kit as an example. There are also component lead bending jigs but these are not needed for most of our applications.

I've used a number of items over the years to space my parts away from the board—flat toothpicks, book matches with the heads snipped off or strips of old business cards placed under the parts until after soldering. They can also be doubled up if you like more space.

Another useful item is a handful of small alligator clips to attach to component leads as heat sinks or ground straps while handling and soldering components.

[I suspect that the risk of destroying semiconductors while soldering may be somewhat exaggerated. I would presume that such things have been made more robust over the years than they were decades ago, and proper soldering techniques (meaning good preparation and quick application of heat) go a long way to minimize component damage from heating. I've been soldering professionally and at home for about 38 years now and never used a heat sink after my mid-teens.

I do admit to destroying one component during soldering without a heat sink, a diode, but that was about 26 years ago. A combination of proper technique, good preparation and luck goes a long way! Of course I can't officially endorse non-use of heatsinking, since employers might take a dim view of that, or someone might ruin some expensive components in their home projects and blame me! —WA8MCQ]

Small glass diodes can be damaged quite easily. This is also a good reason to hold them with long nose pliers before bending the leads to fit the board hole spacing.

I hope that some these comments will be found useful. You are free to use them or not; I don't profess to be an expert by any means, but they work for me.

—de K3TKS, k3tk@abs.net

●●

QRP ARCI STAFF

President

Joe Spencer—KK5NA
3618 Montridge Ct.
Arlington, TX 76016
kk5na@quadj.com

Past President

Jim Stafford—W4QO
11395 West Road
Roswell, GA 30075-2122
(770) 993-9500
w4qo@arrl.net

Secretary/Treasurer and
Membership/Subscription Renewal

Mark Milburn—KQ0I
117 E. Philip St.
Des Moines, IA 50315-4114
mark.milburn@juno.com

Membership Chairman
Steve Slavsky—N4EUK
12405 Kings Lake Dr.
Reston, VA 20191-1611

Awards Manager
Thom Durfee—W18W
3509 Collingwood Ave. SW
Wyoming, MI 49509
wi8w@arrl.net

Contest Manager
Randy Foltz—K7TQ
809 Leith St.
Moscow, ID 83843
rfoltz@turbonet.com

BOARD OF DIRECTORS

Bill Harding—K4AHK
10923 Carters Oak Way
Burke, VA 22015
k4ahk@ix.netcom.com

Hank Kohl—K8DD
2130 Harrington Rd.
Attica, MI 48412-9312
k8dd@arrl.net

Jim Larsen—AL7FS
3445 Spinnaker Dr.
Anchorage, AK 99516-3424
al7fs@arrl.net

Dick Pascoe—G0BPS
Seaview House
Crete Road East
Folkestone, Kent CT18 7EG, UK
dick@trickie.com

Joe Spencer—KK5NA
3618 Montridge Ct.
Arlington, TX 76016
kk5na@quadj.com

Ken Evans—W4DU
848 Valbrook Ct.
Lilburn, GA 30247
w4du@bellsouth.net



QRP ARCI is now taking membership applications and renewals via credit card—*online*—using the **PayPal** system. In fact, we prefer it—this is true for all applicants—worldwide! Simply go to the club website: <http://www.qrparci.org/us2signup.html> and follow the instructions. Be sure to select the appropriate button for the area of the world you reside in (per box below).

PayPal replaces all previous methods of payments for non-US hams, except that you may always send your payment directly to Mark Milburn, our Treasurer. *Funds must be drawn on a U.S. bank and be in U.S. dollars.* Make checks out to: QRP ARCI.

If mailing your application (if renewing, it helps to send in the mailing label from your *QQ*), send it to:

QRP ARCI—Mark Milburn, KQ0I
117 E. Philip St.
Des Moines, IA 50315-4114

Need an Information Pack? Send e-mail to k3tks@abs.net, or send an SASE to:

Danny Gingell, K3TKS
3052 Fairland Rd.
Silver Spring, MD 20904

TIPS: 1. Use the Online Member Lookup feature to keep track of your membership status—check: <http://www.qrparci.org/lookup.html>
2. Is your data on file now correct? Use the online form to send info to our database manager: <http://www.qrparci.org/>

US—\$15 • Canada—\$18 • Non-US/VE—US\$20 per year

New Member or Renewal Form

CALL _____ QRP ARCI# (OR "NEW" IF NEW MEMBER) _____

FULL NAME _____

MAILING ADDRESS _____

CITY _____ STATE/COUNTRY _____

POSTAL CODE (ZIP+4 FOR USA) _____

PREVIOUS CALLSIGN(S) (IF ANY SINCE JOINING) _____

(THE FOLLOWING IS OPTIONAL AND IS NOT RELEASED TO OTHERS)

E-MAIL ADDRESS _____

COMMENTS _____

Become a Famous Author! Write a Review for QRP Quarterly

Have you just purchased a new gadget, rig or kit that you would like to tell the QRP world about? Then write a review and send it to the *QRP Quarterly*! Reviews are handled by our Special Features Editor, Larry East—W1HUE (see page 3 for address). We have no strict guidelines for reviews, but we do ask that you include the manufacturer's basic technical specs and any results of technical tests that you have performed. If you are not sure about some aspects of the device that you are reviewing, don't guess; ask the manufacturer for clarification. (We reserve the right to also contact the manufacturer for additional details or clarification.) Please try to be as objective as possible; tell about the good as well the bad features. Larry prefers to receive articles in machine-readable form, as ASCII text files on PC format floppy disks or as e-mail attachments.

If you want to send word processor files, Larry can handle MS Word 6/95/97, Word Perfect 5/6 and Rich Text Format (RTF) formats. Please don't do any fancy formatting or embed graphics within WP files! Figures (drawings and photographs) can be supplied as "hard copy" (good quality B&W or color prints for photographs) or as digitized images (GIF, TIFF, JPEG, PhotoCD, PCX or bitmap). If you want your disks, drawings, etc. returned, please enclose an SASE with sufficient postage. ●●

IMHO—Ten Things I've Learned From QRP

Gary Breed—K9AY

k9ay@k9ay.com

With apologies to David Letterman, here are my Top Ten reasons why QRP has been a valuable ham radio experience. —*de K9AY*

#10—Wow, you really can work the world with almost no power!

The second QSO with my first homebrew 20M rig was a KH6, which showed me what QRP could do. In contests, I have worked QRP DXCC, WAS, 160M WAS—each in just one weekend!

#9—The outdoors is more fun when you take along a radio

My first attraction to QRP was having an HF radio with me when camping, hiking, picnicking, or just out in my backyard. A rainy day or a cold night in a tent is no big deal if you have something fun to do on the radio.

#8—Little radios are fun to build

Although I have focused more on antennas in the past few years, I find myself thinking about QRP rig design a lot. There is magic in turning a pile of parts into something that really works!

#7—Little radios are fun to operate

Nothing is more fun than “doing more with less.” I still marvel at the efficiency of size, weight and cost that a QRP radio and a simple antenna can deliver. What a great feeling to tell the guy you're working, “I'm up here on the summit of Gray's Peak at



Field Day 2001—1B-10p Battery at our family's cabin in Wisconsin.

14,270 feet.” or, “TNX FER 599 PLUS RPT—RIG HR IS HB—PWR 5W”

#6—Contesting with QRP is a blast

I have seen some of the biggest “big gun” DXers and contesters get excited about QRP. They have discovered the variety I enjoy in my own operating. In the past year, I have competed in major contests with QRP, low power and high power — they were all lots of fun!

#5—QRP is a just a power level

Time for a serious philosophical discussion: What is QRP? My definition is simple—5 watts maximum power output. Which leads to the next item...

#4—QRP is fun without being a major lifestyle choice

I appreciate those who have chosen a minimalist approach to ham radio, but

that's not my thing. If I'm going to run low power, I want the biggest, most efficient antenna and the best receiver. And I will be delighted to work anyone who is using a Tuna Tin transmitter, Neophyte receiver and loading up the raingutter!

#3—QRP taught me to be a better operator at all power levels

QRP really forces you to hone your operating skills. To get the most Q5 QSOs, you need to thoroughly understand propagation, make the right antenna choices, and send (or speak) clearly and accurately.

#2—Sometimes QRP isn't enough

With poor conditions and/or QRM, five watts might not cut it. The Amateur Radio Service rules say we must use the least power necessary to maintain communications. Sometimes you need 50, 250 or 1500 watts for a successful QSO.

...and #1—QRP taught me to listen!

Non-QRPer's think that being heard is the hardest part of QRP. What they forget is that hearing better will help you be heard! You need to hear the other guy for any 2-way QSO. You need to listen carefully to use the right timing for a station to pick out your QRP signal. You need to listen to evaluate propagation and gauge the QRM level. The most important piece of equipment at any ham radio station has the operator's ears mounted on the sides, with gray matter between them! ●●

The Last Word

The *QRP Quarterly* invites readers to submit original technical and feature articles as a service to fellow QRP enthusiasts. Although the *QRP Quarterly* cannot pay for submissions accepted for publication, it will acknowledge, with thanks, authorship of all published articles.

Due to space limitations, articles should be concise. Where appropriate, they should be illustrated with publishable photos and/or drawings.

Full articles should go to any of the volunteer editors for review. Information for columns should be sent directly to the column editor. See the page 3 for addresses. Submit technical and feature articles with a printed copy and a copy on disk, if possible. ASCII text is preferred. Photos and drawings should be camera-ready or in TIFF or JPEG format. Other formats can be used with prior approval.

Technical and feature articles should be original and not be under consideration by any other publication at the

time of submission to *QRP Quarterly* or while the *QRP Quarterly* is reviewing the article. If you contemplate simultaneous submission to another publication, please explain the situation in a cover letter.

Material for possible use in *QRP Quarterly* should be sent to only one of the editorial volunteers, not to several at the same time. The *QRP Quarterly* editors and columnists will transmit the submission to others on the staff if it better fits another category.

Accepting advertisements for publication in *QRP Quarterly* does not constitute endorsement of either the product or the advertiser.

Material cannot be returned unless accompanied by sufficient postage.

The act of mailing a manuscript constitutes the author's certification of the originality of the material.

Opinions express are those of the authors and do not necessarily represent those of the QRP ARCI, it's offi-

cers, Board of Directors, staff or advertisers.

The *QRP Quarterly* will occasionally consider reprinting articles previously published elsewhere if the information is especially useful to members of QRP ARCI. If your article has been published, include the name of the publication and the issue it appeared in. In all such cases, the *QRP Quarterly* will obtain permission to reprint from both the author and the original publication, and will acknowledge the source of the material.

The *QRP Quarterly* will occasionally print information first appearing on QRP-L after obtaining the author's permission and ascertaining that the information is not scheduled to appear in another publication.

Copyright of materials published in *QRP Quarterly* remains with the author. Although the author retains the right to reuse the material, the *QRP Quarterly* requests that reprints of the material in other publications acknowledge the first publication in *QRP Quarterly*. ●●

W4RT
Electronics™

Perfect Accessory Quartet for the FT-817
ONE-TOUCH TUNE™ • **ONE-PLUG POWER™**
ONE-BOARD FILTER™ • **LDG Z-II Autotuner**

Tuning the YAESU FT-817 has Never Been Easier!

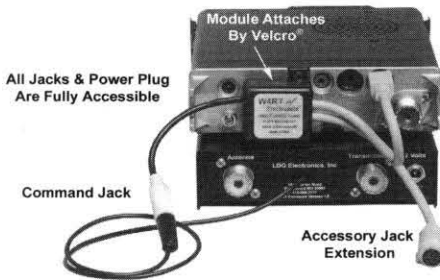

All Jacks & Power Plug Are Fully Accessible

Command Jack

Accessory Jack Extension



ONE-TOUCH TUNE™
\$59.95

Plug to FT-817 ACC Jack

ACC Jack Extension

NEW!

- Works with Manual Tuners (e.g., ZM-2)
- Works with Auto Tuners (e.g., Z-11)
- Requires No External Power
- Commands the FT-817 to Produce An Unmodulated Carrier for Tuning

ONE-BOARD FILTER™

AT LAST THE FT-817 CAN HAVE BOTH CW & SSB FILTERS!
• Collins Mechanical Filters
• 500-Hz CW & 2.3-kHz SSB
• Only \$299.95 INSTALLED

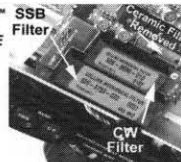

PLUG-IN FILTERS
500-Hz CW: \$124.95
2.3-kHz SSB: \$139.95

ONE-PLUG POWER™

Rapid Charging Now!



\$59.95

Replaces Existing Battery Door and Tray



\$9.95

The Most Comprehensive FT-817 Reference Guide Available! The Famous Yellow Book by VE3AYR

*** Z-11 Owners ***
Make Your LDG Z-11 ONE-TOUCH TUNE™ Compatible!
Only \$9.95 (incl. S/H in USA)

Molex Connector to the FT-817

- 1650 mAh NiMH Batteries
- Over-Current & Over-Temp Fused
- Use FT-817 Internal Charger
- Use NiMH Fast External Charger

W4RT Electronics & LDG Electronics Have Collaborated to Provide You

The Ultimate FT-817 Tuning Solution!

- Tune by Just Pressing the Tune Button on the LDG Electronics Z-11 QRP Autotuner!
- Requires Only ONE-TOUCH TUNE™ and the Z-11 Compatibility Kit. Simple Installation!

LDG Z-11 AUTOTUNER

\$239.95 Package
Z-11 & One-Touch Tune



W4RT Electronics™ Offers the LDG Z-11 Tuner Fully Assembled, Modified and Tested to be ONE-TOUCH TUNE™ Compatible!

ORDER ON-LINE or BY FAX

• **www.W4RT.com** •

W4RT Electronics • fax: 256.880.3866

In the UK or Europe, Contact Waters & Stanton PLC: www.wspc.com
Unless otherwise stated, shipping & handling charges apply. Prices may change without notice.
W4RT Electronics is a Division of Optical E.T.C., Inc. W4RT Electronics, ONE-TOUCH TUNE, ONE-PLUG POWER, & ONE-BOARD FILTER are trademarks of Optical E.T.C., Inc. Copyright © 2001 by Optical E.T.C., Inc. All rights reserved.

BallDog Lambic Key \$24⁹⁵

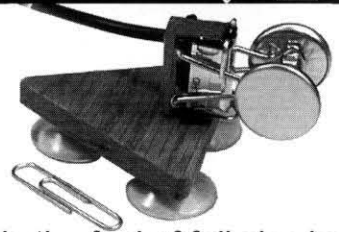

Rivals the feel of full size keys!

1 oz, 2"W x 2.5"L x 1.5"H
Adjustable spacing and tension
3' pre-wired cable with 1/8" plug
Money Back guarantee!
Visa/Master Card Accepted
S & H only \$2.50

Toll Free 1-877-227-9139 AmateurRadioProducts.com

— **FAR CIRCUITS** —

Printed Circuit Board Design and fabrication for Amateur Radio and hobby projects

18N640 Field Ct.
Dundee, Illinois 60118
(847)836-9148 Voice/Fax

Catalog: www.cl.ais.net/farcir/
Email: farcir@ais.net

GigaParts®
Online Superstore!

www.gigaparts.com

Secure On-Line Ordering

Free UPS Ground on orders over \$200



Own the hottest little radio for the coolest price around.

FT-817
\$725.00*

YAESU
Choice of the World's top DX'ers™

Call TOLL FREE (866) 535-4442

4925 University Drive, Suite 140
Huntsville, Alabama 35816
Tel: (256) 535-4442

Email: hamsales@gigaparts.com
Open Mon-Sat 10-7 & Sun 1-4

*Price and availability subject to change

HEX-PAC™
Portable

1. On the move
2. Pick a band
3. Getting ready
4. Up it goes
5. On the air... less than 30 minutes!

MINIATURIZED CONTROLLED FIELD ANTENNAS
Traffie Technology
www.hexbeam.com
421 Jones Hill Road, Ashby, MA 01431-1801
978-386-7900 Phone/Fax 1-888-599-BEAM Toll Free USA

Our K1 transceiver just became a 4-bander! With its small size, low current drain, and 5-watt+ output, the dual-band K1 was already a great rig for home or field operation. But we've taken the K1 to a new level with our KFL1-4 option, which covers 40, 30, 20, and your choice of 17 or 15 meters—all on a single plug-in module. Adding the internal auto-tuner (KAT1), internal AA battery pack (KBT1), and wide-range tilt-stand (KTS1) makes the K1 a truly "trail-friendly" radio. For more details on the K1, as well as on the K2 all-band, 15-watt SSB/CW transceiver, please visit our web site.

"My son built a K1, and was very impressed. As the ex-chief engineer of Heath, may I offer my congratulations for a kit job well done – and I should know!" – Mike Elliott, W8KRR

"This is really a kit? In my 20+ years now of playing with electronics and building kits I have NEVER seen a kit that fits together like this. It's magic." – Randy Rathbun, NV0U

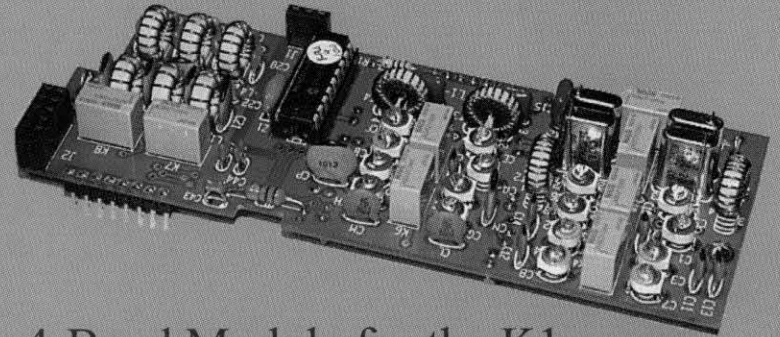

4-Band Module for the K1



www.elecraft.com

 **ELECRAFT**

P.O. Box 69
Aptos, CA 95001-0069

Phone: (831) 662-8345
sales@elecraft.com

