

# QRP Quarterly

Journal of the QRP Amateur Radio Club International

Volume 43 Number 3

July 2002

\$4.95

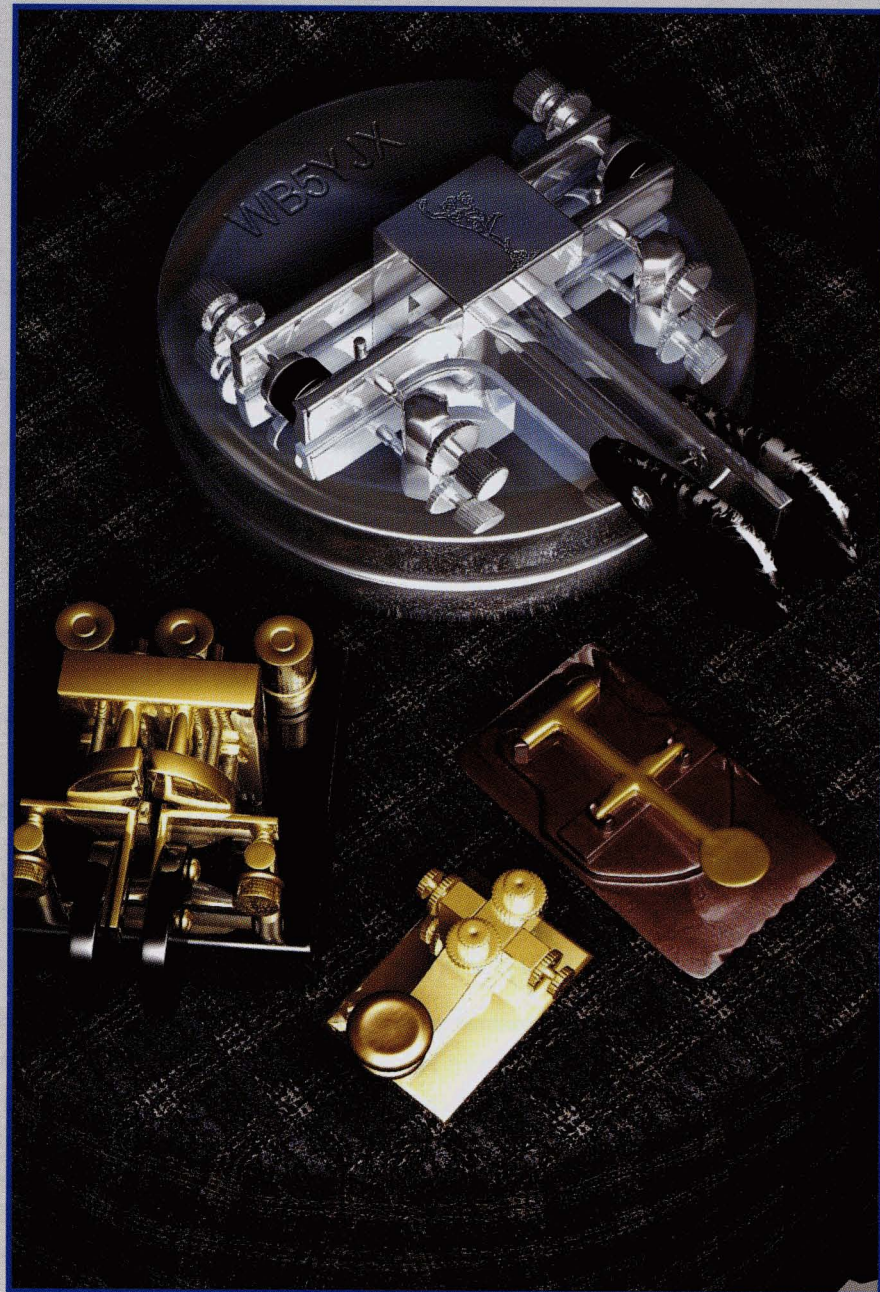

- An Interview with Steve "Melt Solder" Weber, KD1JV
- Reports and Photos from Arkiecon and FDIM
- Reviews: LogiKit Keyer and Contest Software
- End-Fed 1/2-Wave 20M Portable Antenna
- All-QRP Contest DXpedition to Jamaica



QRP ARCI is a non-profit organization dedicated to increasing worldwide enjoyment of radio operation, experimentation and the formation and promotion of QRP clubs throughout the world.

## NEW From Patcomm



## The PC-500 Dual Banders

For \$395.00 you get lots of built-in features such as both CW & SSB modes, an Iambic Keyer with our patented CW Keyboard Interface, adjustable 1 to 15 Watts of output power and Patcomms' unique DVF (Digital Variable Filter) filtering system providing a 600Hz to 2.8kHz continuously variable filter within the AGC loop for superb receiver selectivity. VOGAD and RF Clipping are used on SSB Transmit to provide that Big Radio "Punch". This radio can be ordered with your choice of any two Ham Bands between 160 and 6 Meters, and when ordered with the VOX option is PSK-31 ready. This is the ideal rig for QRP and Portable operation. **ALL THIS FOR ONLY \$395.00**

## New Lower Prices on these Patcomm Radios



### PC-9000 HF+6 Transceiver

Compact, rugged 40 Watt Ham Band Transceiver with our unique DVF (Digital Variable Filter) continuously variable filtering system and our patented CW Keyboard Interface. You get coverage of all HF Amateur Bands plus 18 Watts out on 6 Meters. Low power mode lets you operate QRP at 5 Watts output.

**Reg \$799.00 (FM Adapter \$79) Now \$650.00 Incl FM Adapter !**

### PC-16000A HF Transceiver



**Reg \$1,749.00 Now \$1,295.00**

100 Watt with General Coverage Receive. Collins IF Filters and DSP Audio Filtering make this an exceptional rig. DSP features include 5 "Brick Wall" filters plus Auto Notch and a De-noiser. Other features include our built-in patented CW Keyboard Interface and automatic CW and RTTY Decoder. Operates on CW, SSB and AM with output power adjustable from 1 to 100 Watts. Here is a full featured rig which is easy to use and delivers solid performance.

**patcomm**  
corporation

Phone: (631)862-6511  
Web: [www.patcommradio.com](http://www.patcommradio.com)  
7 Flowerfield Suite M100

Fax: (631)862-6529  
E-mail: [patcomm1@aol.co](mailto:patcomm1@aol.co)  
St. James, NY 11780



# MORSE Express

A Division of Milestone Technologies, Inc.

**"Everything For The Morse Enthusiast"**

- ✓ Keys      ✓ Paddles   ✓ Bugs      ✓ Keyers
- ✓ Software   ✓ Kits      ✓ Books    ✓ Tools

**www.MorseX.com**



*Free Catalog*

**303-752-3382**  
2460 S. Moline Way  
Aurora, CO 80014

A Division of Milestone Technologies, Inc.

## Kanga US

### New Products Available at Dayton:

- Hands Electronics RTX-109 - All Band SSB/CW Transceiver--6 or 20W version.
- R2Pro by KK7B - High performance DC RX module.
- DK9SQ Folded Vertical - All bands 80 - 10 including WARC. No Traps!
- Torment Electronics VFO Module in a Clock Oscillator Module.

### Coming soon from Hands Electronics:

- Monoband xcvr for PSK31/MFSK/RTTY for any band  
3.5 - 50 Mhz

### Still available:

- Spectrum Analyzer and Tracking Generator by W7ZOI and K7TAU
- R1, miniR2, T2, and LM2 by KK7B
- DK9SQ Mast, Loop, and Dipole
- Kits from Kanga Products, Hands Electronics, and Sunlight Energy Systems



**Kanga US**  
3521 Spring Lake Dr.  
Findlay, OH 45840 419-423-4604  
[www.bright.net/~kanga/kanga/kanga@bright.net](http://www.bright.net/~kanga/kanga/kanga@bright.net)

# QRP Books

**Quality Books for the Low Power Enthusiast**

**Antennas ♦ RF Design ♦ Reference Manuals**  
**Operating ♦ Proceedings ♦ Measurement**

**21 Myers Heights Road Lansing, NY 14882**

**[www.QRPBooks.com](http://www.QRPBooks.com)**

# Table of Contents

## QRP Quarterly

Volume 43 Number 3 — July 2002

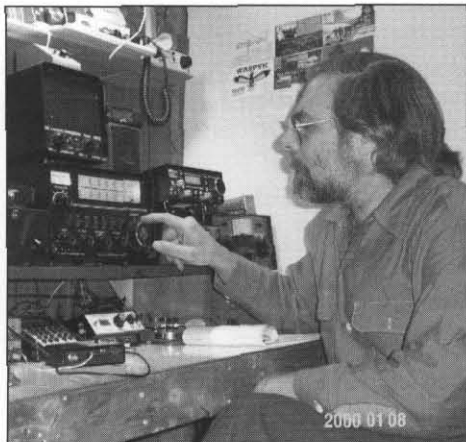

page 6

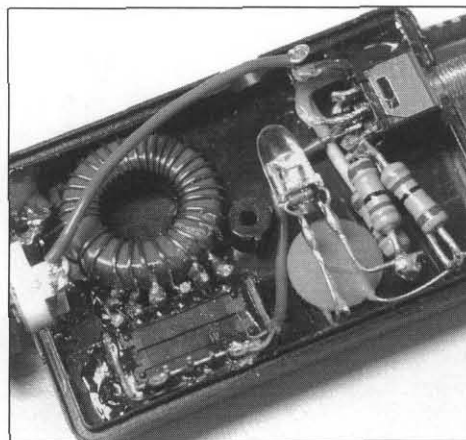

page 22



page 44

### Technical

- 8 Idea Exchange—Mike Czuhajewski—WA8MCQ  
*Cheapskate's Portable Power*—Joe Everhart, N2CX  
*Testimonial for the WA8MCQ BNC Repair Tool*  
*NE602 Not Gone for Good, Part 2*—Paul Harden, NA5N  
*KD1JV Frequency Counter Mod*—Monty Northrup, N5FC  
*Overtone Operation with the NE602/612*—W3IRZ  
*Improved Signal Isolation for MFJ Coax Switch*—Sam Billingsley, AE4GX  
*Micro Moments #1: An Intelligent Controller for your Rig*—George Heron, N2APB  
*Homebrewed Open-Wire Feedline*—Charles Moizeau, W2SH  
*Source of Ceramic Spreaders*—William Colbert, W5XE  
*Open Wire and Spreaders, A Cynic's View*—James Duffey, KK6MC  
*Two PCB Paddles*—Steve Weber, KD1JV  
*More on Diode Detector Response*—WA8MCQ  
*QRP On-line*
- 22 20-Meter End-Fed 1/2-Wave Antenna, Tuner and SWR Indicator  
—Louis Hlousek—W7DZN
- 24 Digital QRP Homebrewing—George Heron—N2APB  
*The PIC-Based APRS Weather Station*  
*Digital QRP Breadboard—First Application: SWR Measurement*
- 34 Test Topics and More...#12—Joe Everhart—N2CX
- 37 Convert Your Power Meter to Read CW and PEP—Ian Keyser—G3ROO
- 38 Variable Power Supply Regulator/Current Limiter—Steve Weber—KD1JV
- 41 QRV? "Seeing" Radio Signals—Mike Boatright—KO4WX

### Operating

- 30 QRP is! (Confessions of a QRO Op Gone QRP)—Ed Muns—WØYK
- 43 Milliwattling: 30M QRSS Beacon Activity—Jim Hale—KJ5TF
- 52 2002 FYBO Results—Bob Hightower—NK7M
- 54 QRP Contests—Randy Foltz—K7TQ  
*Winter Fireside Sprint 2002*  
*2002 Spring QSO Party*
- 58 Contest Announcements
- 60 Kazo Kontesting—Michael Sealfon—WA2OCG

### Reviews

- 46 Review: LogiKit CMOS-4 Keyer Kit—Tom Hammond—NØSS
- 48 Let's Talk About Contest Logging Programs—Randy Foltz—K7TQ

### Columns and Departments

- 3 Across the Editor's Desk—Mike Goins—WB5YJX
- 4 From the President—Joe Spencer—KK5NA
- 36 QRP Clubhouse—Mike Fletcher—KL7IXI/7
- 40 Ramblings of a Displaced Cajun Lad in Maine—Joel Denison—KE1LA
- 61 IMHO—Homebrew is Alive and Well—Jerry Hall—WØPWE

### Miscellaneous

- 4 Two More Inducted into QRP Hall of Fame in 2002
- 6 Interview: Steve "Melt Solder" Weber, KD1JV
- 20 Arkiecon Report—Mike Goins—WB5YJX
- 42 Member Profile: RV3GM/QRP—Oleg V. Borodin—RV3GM
- 44 Ramblings of a Peaux Cajun Lad at FDIM—Joel Denison—KE1LA
- 47 NoGa Donates K2 to Science Museum—Pickett Cummins—AD4S
- 63 New or Renewal Membership Application
- 63 QRP ARCI Staff and Directors
- 64 The Last Word

## QRP QUARTERLY EDITORIAL STAFF

Managing Editor  
**Michael Goins—WB5YJX**  
3030 Shadowbriar, #225  
Houston, TX 77082  
mgoins@usa.net

Associate Editor  
**Larry East—W1HUE**  
15355 S. Rimline Dr.  
Idaho Falls, ID 83401-5917  
w1hue@arrrl.net

Associate Editor  
**John King—KB3WK**  
9936 Whitworth Way  
Ellicott City, MD 21042  
kb3wk@arrrl.net

Associate Editor & Idea Exchange  
**Mike Czuhajewski—WA8MCQ**  
7945 Citadel Dr.  
Severn, MD 21144-1566  
wa8mcq@comcast.net

Associate Editor—Contests  
**Randy Foltz—K7TQ**  
809 Leith St.  
Moscow, ID 83843  
rfoltz@turbonet.com

### REGULAR COLUMNISTS

Digital QRP Homebrewing  
**George Heron—N2APB**  
2419 Feather Mae Ct.  
Forest Hill, MD 21050  
n2apb@amsat.org

Milliwatting  
**James L. Hale—KJ5TF**  
HCR 65 Box 261B  
Kingston, AR 72742  
kj5tf@madisoncounty.net

QRV  
**Mike Boatright—KO4WX**  
1013 Latham Rd.  
Decatur, GA 30033  
ko4wx@mindspring.com

Test Topics...and More  
**Joe Everhart—N2CX**  
214 NJ Rd.  
Brooklawn, NJ 08030  
n2cx@voicenet.com

QRP Clubhouse  
**Mike Fletcher—KL7IXI/7**  
Poulsbo, WA  
kl7ixi@attbi.com

peaux displaced cajun lad...  
**Joel M. Denison, Sr—KE1LA**  
POB 542  
Strong, ME 04983-0542  
hamjoel@juno.com



## Across the Editor's Desk

Michael Goins, WB5YJX—Managing Editor

mgoins@usa.net



Welcome to the July issue of *QRP Quarterly*! Things have been a bit hectic with the magazine in the recent past, and a lot of people have worked really hard behind the scenes to get the April issue and this issue done in record time so that we are back on our production schedule. We are hopefully back on track now, and each future issue will be meet the coming deadlines. Thanks to all for your understanding.

As the new managing editor, I want to take a moment to introduce myself to those of you who don't already know me. I'm down in the Houston area, and as hard as it is for me to believe sometimes, I've now been licensed for twenty-five years. Always a QRP'er, I've operated for the entire time with low power. The last four or five years I have run only one watt, operating primarily on SSB and CW (with an occasional excursion into PSK to check it out). Through the years, I've used most of the QRP rigs out there at one time or the other, and I've also used several QRO rigs turned down to one watt. DXing has always been one of my favorite pastimes, and I've worked a lot of countries using this power and a relatively simple homebrew multi-band vertical dipole and wire antennas.

A recent move from some acreage out in the country to an apartment in the city

will likely see me operating primarily CW and PSK now, as I try to make sure that my operating doesn't interfere with others. That same move will probably necessitate me writing an article or two about "different" antennas (like the magnetic loop for 10-40 meters I'm now working on), unless someone already has an antenna or two they'd like to share with those of us operating under severe antenna restrictions.

This column in the April issue contained a new set of submission guidelines. If you have an article you'd like to submit, please follow those guidelines and forward it to me for review. I promise you will hear from me in a few days. And don't worry about being a "professional writer." There are some very talented individuals here who can help with the writing part.

Finally, I want to take a moment to say thanks to all who contribute to not only this issue, but to the magazine, both "up front" with their regular columns, and from "behind the scenes." Some of the most innovative hams in the world write for *QRP Quarterly* on a regular (or irregular) basis, and you have seen, and will continue to see, their names and call signs within these pages. Without the many hours of assistance provided by these individuals, there would be no *QRP Quarterly*. They are the magazine.

Welcome to this issue. We hope you enjoy it!

—Mike Goins, WB5YJX

### On the July Cover:

*No, it's not a photograph! Sean McCarty did these 3D illustrations of some of my keys. One on the far right is a plastic (darned if it doesn't LOOK like plastic too!) non-functional telegraph key that was a Rin-Tin-Tin prize from the late '40s. The big one is my Long Island Mercury (I hadn't intended my call to be so prominent), the small straight key is one of Marshall Emm's from Christmas last year and the little dual paddle is one of G4ZPY's. Now, let's hear from Sean:*

—WB5YJX

"Ok, a little biography, here it goes...I am 20 years old and interested in graphics since the age of 17. I have gone through a series of interests before finding my true calling and passion. I am majoring in the graphic arts and am aspiring to become a professional 3D modeler, or 3D animator for the next 'Shrek' type film. I do have a definite interest in HAM radio. In fact I have a lot of similar interests to my fathers' (Roger, KD6CC), from audio to glowbugs. I guess you could say that I inherited my Dad's analytical thinking and my Mom's artistic abilities."

—Sean McCarty

## From the President

Joe Spencer, KK5NA—QRP ARCI President

kk5na@quadj.com



Well, thanks to Mike Goins, the staff, and a few others, *QQ* is well back on track and the content just keeps getting better. It is like QRP in general, full of good substance, with an outstanding group of people that keep it growing and providing for the community. We are fortunate to have such excellent contributors to the *QQ*. Most issues are worth the price of the whole year's subscription. Two of my favorites are the issues with

Paul Harde's articles "Solar Phenomenon of the Active Sun" from January and April of 1998. If you don't have these in your library they are worth tracking down.

This year's HOF inductees are two at the top of the QRP experience and have provided the hobby with many great article, projects and experiences.

FDIM was a rousing success and we owe a hearty "Well Done" to all those responsible. All the activities and presentations were excellent and it seems a great time was had by all.

I hope you all have a great QRP Field Day this year and hope to work you on the air there or in one of the other upcoming

QRP events. There are many good ones: QRPTTF, QRPAField, FYBO. A favorite of mine is "The Flight of The Bumblebees" put on by the Adventure Radio Society (ARS), coming in July. These and many other contests now have QRP sections that provide opportunity to communicate with each other and compete with ourselves to see what we can do with little power and minimal equipment. Look for the NOR-TEX QRP group as K5RAC in most of these QRP events.

As usual, I am late getting this article to Mike, so I will cut it short and wish you all good QRP and good DX.

—Joe KK5NA

## Two More Inducted into QRP Hall of Fame in 2002

The QRP Hall of Fame is an honor bestowed by the QRP ARCI on those who have made outstanding contributions to the QRP community (membership is not required to be nominated or inducted). Starting in 1992, and then picking up again from 1996 to present, there are currently 27 who have been inducted.

We are pleased to announce that two more people were inducted into the QRP Hall of Fame this year, as announced at the QRP banquet at Dayton. They are:

Rich Arland, K7SZ  
Jim Kortge, K8IQY

Both are well known figures in the QRP community, and have made substantial contributions over the years. Here is some information on them, compiled from some of the nomination letters.

### Rich Arland, K7SZ

[Compiled from nominations written by W4DU and WA8MCQ]—

Rich served three terms on the Board of Directors of the QRP ARCI and has published a number of QRP items, but unlike most people, he wasn't just "preaching to the choir" by writing for the QRP journals, to be read only by those already in the QRP community. His works have appeared for

the most part in the mainstream ham press, giving widespread publicity to our aspect of the hobby. He not only entertained and enlightened us, but he also kept—and keeps—QRP in the eye of the general ham community, acting as a spokesman and "evangelist" of QRP to the mainstream of amateur radio.

Rich has written for many ham journals. This includes a QRP column in *World Radio* magazine that ran for more than 6 years, a QRP series in *CQ* magazine, and numerous QRP articles in *QST* during the mid to late '90s. He has authored four books on QRP, one of which is published by the ARRL.

In addition to writing on the subject, Rich has spoken on QRP at hamfests around the country. His presentations are informative, entertaining, and well received by the attendees. Rich's writing and speaking efforts have gained national and international recognition and respect for him as a radio amateur and for QRP as a vibrant force in our hobby. Many current QRPers were first introduced to it by Rich's efforts. For two years now, Rich has been the master of ceremonies at the New Jersey QRP Club's Atlanticon QRP forum.

The past five years have seen an unprecedented increase in QRP activity and recognition of it as a major part of

amateur radio. Many have called QRP the "renewal of amateur radio." Some of the credit for this is due to the work Rich has put into it. The ARRL recognized both the value of QRP and Rich's contribution when, in January 2000, they added a QRP column to *QST* and asked Rich to be the first editor. Just like his QRP column in *World Radio*, its appearance month after month serves as a subtle but constant reminder to all readers that QRP is a viable, respected and vital side of our hobby, enjoyed by many.

Rich's QRP voice was also heard worldwide, literally, expounding on QRP. The well-known short-wave radio station HCJB in Quito, Ecuador, has a regular program on ham radio. They asked Rich to record a six-part series on QRP, which was broadcast at least annually for many years.

One nomination letter said, "I firmly believe that the QRP Hall of Fame should not only honor those who are currently well known and popular within the QRP community, both in the traditional paper publications and on the QRP-L mail reflector, but should also honor those who have made significant long term contributions to QRP, and especially those who have been publicizing QRP to the 'outside world' and bringing others into the QRP community. Rich fits both categories."

## Jim Kortge, K8IQY

[Compiled from the nomination submitted by George Heron, N2APB]—

Jim's contributions to the QRP and homebrewing community over the last four years have been nothing short of spectacular. He is a meticulous and creative RF designer, a producer of kits, a patient and informative instructor, a public speaker at QRP events, an accomplished and published technical writer, and an absolute master craftsman who has done more to champion the extremely successful "Manhattan-style" construction technique than anyone else in our hobby.

[While Jim readily admits that he did not create the technique, which has been around for quite some time, he did introduce it to the QRP community and helped make it very popular. —WA8MCQ]

Kortge is the designer of the immensely popular 2N2/40 Transceiver, a 40M transceiver constructed solely of 2N2222 transistors and winner of a NorCal design contest a number of years ago. He wrote an article, published in NorCal's QRPp magazine, concerning the 2N2/40, and it was the subject of tremendous excitement in ensuing years as others built his design.

In the recent 8 months, he has sponsored and actively "manages" a very popular "2N2/40" email list on Yahoo, wherein over 20 hams have been building their own versions of Jim's 2N2/40 transceiver. He has painstakingly encouraged every neophyte homebrewer, helped to source and find parts, and has updated his design to yield more readily reproducible results—the sign of a good design, and of an excellent designer. There are many 2N2/40 transceivers on the air now because of Jim's assistance and careful guidance along the way, and that group is very loyal and appreciative to Jim. [Although a relatively small number of people actually built the rig by way of the mail reflector, at one point there were about 150 subscribers to it, showing the intense interest in the subject. —WA8MCQ]

Since designing the 2N2/40 Transceiver, K8IQY, has evolved the design to produce a 2N2/6 Transverter. This project was the subject of a paper and talk at a prior year's Atlanticon and FDIM QRP forums. To listen to the presentation, and to read the very thorough technical manuscript which was published in the respective proceedings, even a staunch and

inveterate QRP technical veteran (such as some of us) stands in awe of his work.

Jim then went on to build another variant of the 2N2-series, but this time focusing on the Manhattan-style technique that made him famous. He designed and produced the 4017 Transverter, which again was presented in full technical glory at Atlanticon and FDIM QRP forms. Further, the design was so good and so sought after, the NJQRP collaborated with Jim to produce a kit of his 4017 design. This project was very well received, and ultimately sold over 200 kits around the world.

His next project is not as well known because it is so new on the scene, but many people will get a chance to see and hear of it at the Atlanticon QRP Forum this year. Jim is presenting a topic close to his own interests—crystal calibration and measurement techniques, and I can tell you (since I've just completed editing the *Proceedings*) that the paper is just awesome. Further, the NJQRP Club is once again collaborating with Kortge to produce the test equipment he's describing, in the form of a Precision VXO Kit which will be announced at Atlanticon 2002. I predict that this project will be of great interest to many hams in the QRP and homebrewing community. [WA8MCQ note—I was at Atlanticon in April. The paper and presentation were both outstanding, and the kit form of the Precision VXO is a work of art. Due to demand from attendees, the NJ QRP Club is going to produce a kit of the crystal test fixture itself, in addition to the VXO.]

Jim Kortge is an affable, modest and very accomplished technician in the QRP and homebrewing scene. His technical, speaking, publishing, and educational contributions stand heads and shoulders above the average QRPer, and we are so fortunate to have him in our hobby.

## Administrative notes:

The QRP Hall of Fame year used to be kicked off with a call for nominations in the October issue of the *QRP Quarterly*, but we later moved that to January. Unfortunately, this year's January issue came out in April. Last fall I had asked the club to find someone else to administer the program, but when April rolled around, no one had been found. When it appeared that there would be no HoF this year, I quickly offered to come out of retirement.

Time was short and things would have to be done in somewhat of a last minute panic, but that didn't worry me since I had already done things that way twice before! In both cases, nomination letters were received early, but I was late in starting up the balloting process. This time was a bit different since there would be little time to get nominations sent in. But with the Internet, it was possible to get the word out to a large QRP audience very quickly, and we received nominations on 14 people.

There are no quotas or limits for being inducted. Anyone who gets at least a 2/3 FOR vote is inducted. (The voting body currently consists of the officers and board of directors of the club, and the last two sets of inductees are offered the opportunity to vote as well, if they wish).

There are no nominating committees; nominations are accepted from anyone and everyone who wants to send one in. It's open to the entire QRP community, whether a member of the club or not, and membership is not required to be nominated or inducted.

If your favorite QRP hero doesn't yet appear on the list below, start thinking about how you'll write your nomination letter, and have it ready to go when the call goes out next January.

—de WA8MCQ

Chuck Adams, K5FO (1998)	Paul Harden, NA5N (1999)
Brice Anderson, W9PNE (1996)	Wes Hayward, W7ZOI (1996)
Rich Arland, K7SZ (2002)	Doug Hendricks, KI6DS (1997)
Dave Benson, NN1G (1999)	George Heron N2APB (2001)
Michael Bryce WB8VGE (2000)	Jim Kortge, K8IQY (2002)
Wayne Burdick, N6KR (1998)	Roy Lewallen, W7EL (1992)
George Burt, GM3OXX (1996)	Rick Littlefield, K1BQT (1996)
Jim Cates, WA6GER (1998)	Dick Pascoe, GØBPS (1997)
L. B. Cebik, W4RNL (1999)	Randy Rand, AA2U (1992)
Mike Czuhajewski, WA8MCQ (1997)	C. F. Rockey, W9SCH (1996)
Tom Davis, K8IF (1996)	Gus Taylor, G8PG (1998)
Doug DeMaw, W1FB (SK) (1992)	Adrian Weiss, WØRSP (1996)
Rev. George Dobbs, G3RJV (1992)	Peter Zenker DL2FI (2001)
Joe Everhart N2CX (2000)	??? (2003)

Current members of the QRP Hall of Fame, with year of induction shown.

## Interview: Steve "Melt Solder" Weber, KD1JV

QQ staff

<http://www.qrparci.org>

This month's interview is Steve "Melt Solder" Weber, KD1JV. Steve lives and works in the White Mountains of New Hampshire, and is known to most of the folks in QRP radio operating as the developer and packager of a number of special, very limited-run kits. Current "Melt Solder" offerings include a LED Frequency Counter/Digital Dial, and his newest personal build (and we hope future kit), "The Backpacker," a shirt-pocket sized dual band, DDS rig. Past kits have included the MS-15 and the MS-30 VXO tuned QRP transceivers, a digital RMS RF watt meter, several keyers (including a version of the famed W7ZOI 555 keyer in SMT), and DDS VFOs. All are no longer available. Details of his current offering of limited edition kits are available at Steve's website at <http://www.qsl.net/kd1jv/>.

A guest speaker at Alanticon in 1999, Steve presenting a well-received paper entitled, "Troubleshooting 101." His most recent claim-to-fame is as the designer/developer of the latest NorCal kit offering, the "Nor'easter," a digital, PLL tuned short-wave radio designed to be built in the ubiquitous Altoids tin. Doug Hendricks of NorCal announced this new radio kit while at Arkiecon in early April, and the Nor'easter is due out sometime later in the year (for details on the Nor'easter and a multitude of other great information, see the NorCal site at <http://www.fix.net/~jparker/norcal.html>).  
—Editor

### Now the interview:

**QQ:** Tell us about you, Steve. Let's start with the non-radio stuff first.

**SW:** I was born and raised in South Plainfield, New Jersey, which is in the central part of the state. I lived and went to school there until going away to college to study Electrical Engineering at Lowell Technological Institute, in Lowell, Massachusetts. Unfortunately, I never got a degree, mainly due to the fact I had no interest in, and failed to pass (several times), Organic Chemistry, a required course.

Instead, I got a job at a very small, start-up electronics company which produced custom load cells and strain gauge instrumentation. It was here that my self-taught electronic skills were honed, polished, and greatly expanded. I worked at this job for about 10 years before moving on.

Eventually, I left the electronics field for various reasons (okay, I got laid off and didn't feel like looking for a new job), and became what is best described as a "mountain bum" for a number of years. During

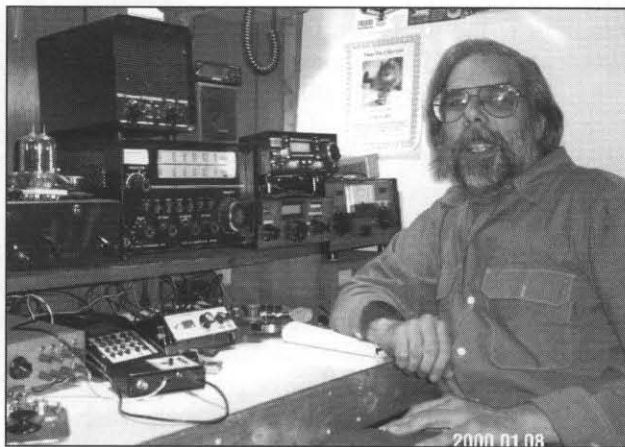

**Steve Weber, KD1JV has earned his "Melt Solder" moniker with many homebrew projects. Just a few of them are evident in this photo.**

this period, I hiked most of the Appalachian Trail, spent several summers as the caretaker of various hiker cabins in Vermont and New Hampshire, spent a summer in Yellowstone Park, and in general, enjoyed a peaceful, stress-less existence.

Life was good until my life savings started to run out and I realized it was time to settle down again. Not wanting to live in or near the "big city" again (or to look for a "real" job after having been out of the industry for such a long time), I started up a TV repair shop in Berlin, New Hampshire so I could continue to enjoy hiking and camping in the near-by wilderness areas.

**QQ:** Steve, how long have you been operating at QRP power levels?

**SW:** I guess since I first became a ham back while I was in high school in 1968. I always liked to build one-tube transmitters, and I see in one of my old logs I made a contact across town to a friend of mine

on 40 meters using a two transistor, 120 milliwatt (input) transmitter on 2/14/1969. I spent most of my time on 2 meters though, using a five watt AM tube transmitter built from plans in the Handbook. Worked all over the Tri-State area with that rig and a five element beam.

**QQ:** At what level do you do most of your operating?

**SW:** Mostly at about five watts for CW. A little more on SSB.

**QQ:** Tell us about your current station.

What equipment do you use, what modes do you operate, what antenna(s) do you use fixed (and/or portable), etc.

**SW:** My station consists mostly of a collection of homebrew gear. I have an old Drake 2B receiver that occasionally gets used, and a recently acquired Patcomm 9000, which is used mostly for SSB or on the bands I don't have a homebrew rig for. I only do CW, and SSB occasionally, and haven't gotten into any of the digital modes or anything exotic. My antenna is a simple, coax feed, three-band fan dipole, supported by a five foot PVC mast in the center of the roof of my single

story repair shop. I also have an Astron A-99 CB 5/8 vertical, tuned to 10 meters.

I often operate in the field during the summer months. When in the field, I use a N2CX "Gusher" dipole. This summer I'll also be using a new "tent pole" vertical for 20 meters above the tree line areas.

**QQ:** What was your first station? Your first QRP station?

**SW:** Hum, The first station was very modest, being a poor high school student. I first started by trying to use a five tube, Heathkit general coverage SWL Receiver, and a Johnson Viking Adventurer transmitter loaned to me by my neighbor. Never made a single contact with that set up, and probably made a lot of QRM, hi. It took me a while, but I was able to save up for a Hammarlund HQ-110. It wasn't much better than the Heathkit, and I didn't keep it long. Eventually, thanks to a part-time job after school, I was able to save up enough money to buy a used Drake 2B (not the one



I have now though). That was when I finally started to make contacts.

The first QRP station I had had to be one of the many one tube transmitters I was fond of building in high school, and of course, the five watt 2 meter AM rig mentioned earlier.

**QQ:** When you were first getting started in amateur radio, did you have an "Elmer" or mentor? If so, how valuable was the experience?

**SW:** My dad was a TV repairman, which is maybe why I got interested in electricity and electronics at a very early age. He was also a great help in bringing home old TV and radio chassis for me to strip for parts.

My best friend's dad was a ham and a top-notch homebrewer. Just looking at the stuff he built inspired me greatly. Then there was the guy up the street from me, who was a VHFer. He gave me parts and loaned me his nice Millen grid dip oscillator (GDO) and his Greenlee punches. Plus all the guys at the local radio club. So, yes, I'd have to say they were all invaluable to me as a young ham and homebrewer.

**QQ:** So your interest in amateur radio really did have an influence on your choice of career paths, or was it that your career path lead you to amateur radio?

**SW:** My interest in building stuff lead me to ham radio, and that did indeed lead me into a career in electronics. Having an Advanced class ham license and a First Class Radiotelephone ticket with radar endorsement by the time I had graduated high school no doubt sealed my fate.

**QQ:** Do you do any specialized operating, like contesting, DXing, foxhunting, mobile, or portable operating? Any specialized gear you use for it?

**SW:** I'm mostly a builder, not an operator. I like jumping into the various QRP contests and sprints now and again, and I try to work most of the field events, but not in a competitive way. I do try to work DX when I hear it, but I don't actively chase it. I rarely drive farther than to the grocery store, so mobile operation is of no interest here, and the foxhunts have gotten too crazy for me to participate anymore. I am doing more and more portable work, like putting the Appalachian Trail on the air.

**QQ:** Do you belong to any radio clubs or organizations?

**SW:** No, neither local, or nationally. There's simply not enough hams in this

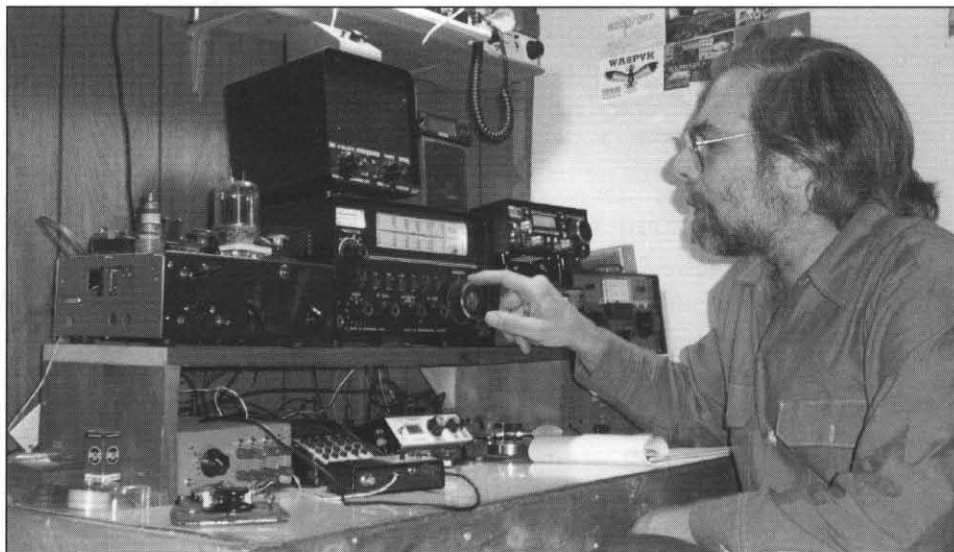

Imagine this shack setup the next time you work KD1JV.

area to support a local club. It was tried once, and didn't last long.

**QQ:** One of the greatest things about amateur radio is that there are so many different areas in which to get involved.

What are your primary interests at the moment, and what areas of radio have you been involved with in the past?

**SW:** My major interest has always been, and most likely will always be, the designing and building of stuff, although someday I really should put down the soldering iron for a while and concentrate on operating, hi.

**QQ:** Sometimes operating at low powers can be a real challenge, even for those with experience. What advice would you give someone just getting started in low power (QRP) radio?

**SW:** I'd tell them to put up the best arial they can and learn to be patient and persistent.

**QQ:** Where do you see QRP/amateur radio going in the future?

**SW:** I have no idea. Hopefully, we will continue to see the ranks of QRP operators grow and amateur radio in general to be healthy and around forever. ●●

### A Sad Note: Roger McCarty, KD6CC, SK

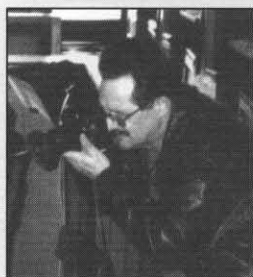

Just prior to going to press, an automobile accident in Riverside, California took the life of Roger McCarty, KD6CC, father of Sean McCarty, the graphic artist who did this issue's cover art.

For those who may not have known Roger, he was active as a member of Lake Perris QRP Society, in Riverside County, California, and he was both an excellent solid-state and glowbug builder. According to those who knew him best, he was also a rock-solid solid CW man.

I barely knew Roger myself, the two of us having only just recently met when I emailed him about some graphic artwork containing his name and call that had appeared in the front part of *QST* a few months ago.

One thing led to another, as they tend to do sometimes when QRPers talk, and we started out discussing the artwork, and ended up talking about building, chasing DX, and low power operations in general. It was in that first conversation that he mentioned it had been his son, Sean, who had done the artwork that appeared in *QST*, and he made sure I knew just how proud he was of Sean's ability.

This month's cover features Sean's artwork, and it seems only fitting that it worked out to be a variety of special CW keys and paddles. Please consider it a tribute to a CW op from his son, his many ham friends, and from those of us who barely had a chance to meet him.

—WB5YJX

# Idea Exchange

## Technical tidbits for the QRPer

Mike Czuhajewski—WA8MCQ

wa8mcq@comcast.net

### IN THIS EDITION OF THE IDEA EXCHANGE:

*Cheapskate's Portable Power*—Joe Everhart, N2CX

*Testimonial for the WA8MCQ BNC Repair Tool*

*NE602 Not Gone for Good, Part 2*—Paul Harden, NA5N

*KD1JV Frequency Counter Mod*—Monty Northrup, N5FC

*Overtone Operation with the NE602/612*—W3IRZ

*Improved Signal Isolation for MFJ Coax Switch*—Sam Billingsley, AE4GX

*Micro Moments #1: An Intelligent Controller for your Rig*—George Heron, N2APB

*Homebrewed Open-Wire Feedline*—Charles Moizeau, W2SH

*Source of Ceramic Spreaders*—William Colbert, W5XE

*Open Wire and Spreaders, A Cynic's View*—James Duffey, KK6MC

*Two PCB Paddles*—Steve Weber, KD1JV

*More on Diode Detector Response*—WA8MCQ

*QRP On-line*

### Cheapskate's Portable Power

Cranking right along, here's #42 in the endless series of Joe's Quickies from QRP Hall of Fame member Joe Everhart, N2CX of Brooklawn, NJ—

A really neat feature of QRP operation is that you are not tied to the ac power grid. Most of the time, in fact, low-powered rigs will operate for hours and hours using only small portable battery packs. These take a number of forms and can be seen in ads at the back of *QST* and at various hamfests. Available in several varieties, they are 12V gel cell batteries packaged in a fabric pouch for great portability. Weighing at most a couple of pounds, they even feature belt loops for use with hand-held radios.

Several years back, Radioshack.com had a special deal on one for under \$30.00 that I did not buy at the time and was sorry for later. I figured that the Dayton Hamvention was a good place to buy one, so I searched the flea market and vendor stalls in a quest to find one. But I suffered sticker shock at the price. There were none for sale at less than \$50-60! Being basically frugal by nature (my XYL, of course, says I'm cheap), I decided to do without.

But my fellow NJQRP cohort in crime George Heron, N2APB, reminded me that as a certified homebrewer I should build my own. And furthermore I couldn't be in a better place to find the parts for one!

A very short trek through the flea mar-

ket area uncovered a gentleman selling 12V, 2.1 ampere-hour gel cell "pulls" from medical equipment. When asked how much, he replied that they were \$3.00 each or 5 for \$10.00. What's more, he said that if I had a voltmeter I could select ones most likely to be good. A short trip to another vendor netted a DMM for \$8.00 to do the testing. Figure 1 is a photo of one of the batteries.

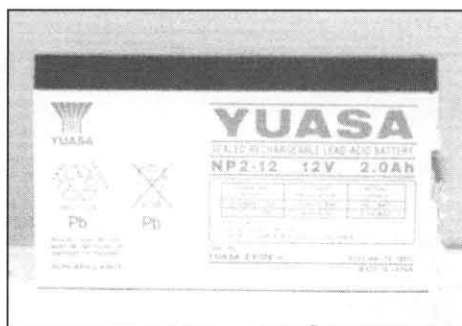

**Figure 1—An example of a typical surplus gel cell battery.**

Another vendor was selling cell phone and camera cases. For \$12, I got a good-quality unit that was a good fit for one of the batteries. It had a Velcro™ flap for top access and a belt loop to make it easy to carry.

Once home, the pack went together very easily. I soldered a length of twin-conductor speaker cable directly to the battery terminals and put a standard 5.5 x 2.1

mm coaxial power jack on the other end. With a double plug cable (more about that later), this could power my Sierra, NC-20 or other homebrew QRP rigs. Now, this was a fast construction job done the night before an NJQRP meeting, so I really did not think things through as well as I should have.

The next morning I stuffed the cable into the pouch and packed it into a box of show and tell stuff for the meeting. Within a few seconds I smelled smoke! Whoops! I suspected the portable power pack, so I pulled it from the box and found it was hot. Upon lifting the flap, I discovered that the two-conductor cable, for then unknown reasons, had charred and shorted the two conductors together. Even small gel cells have a low enough internal resistance that they can supply lots of amps to a short circuit.

Now, how to remove the short! The wires were soldered directly to the terminals, so I could not easily disconnect them and they were smoking hot! Wire cutters were not immediately handy, and besides, I'd have to carefully cut the wires one at a time to keep from burning up my dikes. I used a paper towel to yank the wires off, but still ended up with singed fingers. Needless to say the show-and-tell ended up being an object lesson in what not to do.

Failure analysis showed that the outer conductor of the coaxial power jack had shorted to the exposed "+" battery terminal when the cable had been stuffed into the pouch. With no short circuit protection, the wires got hot enough to melt the insulation so they shorted directly together. Okay, we learn from our mistakes (at least the ones we survive), so now it was time to rebuild, but the next time things would be done right.

The second version incorporates several protective measures:

The wires are not soldered directly to the battery lugs, but connected with insulated slip-on terminals (Radio Shack 64-4039). This lets you yank 'em off quickly if something goes wrong.

A solid-state "fuse" is wired in line with the "+" lead to limit short circuit cur-

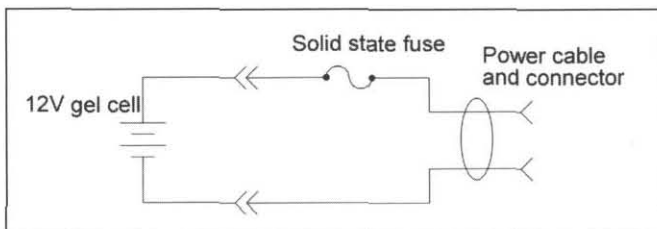

Figure 2—Battery power source with protective “fuse.”

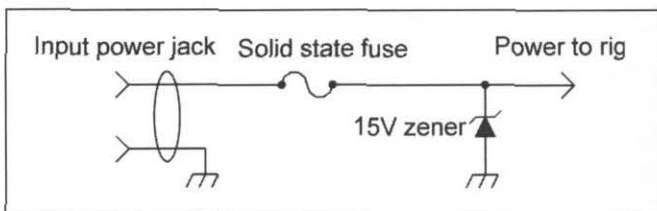

Figure 3—Modernized “dummy diode” with solid-state “fuse.”

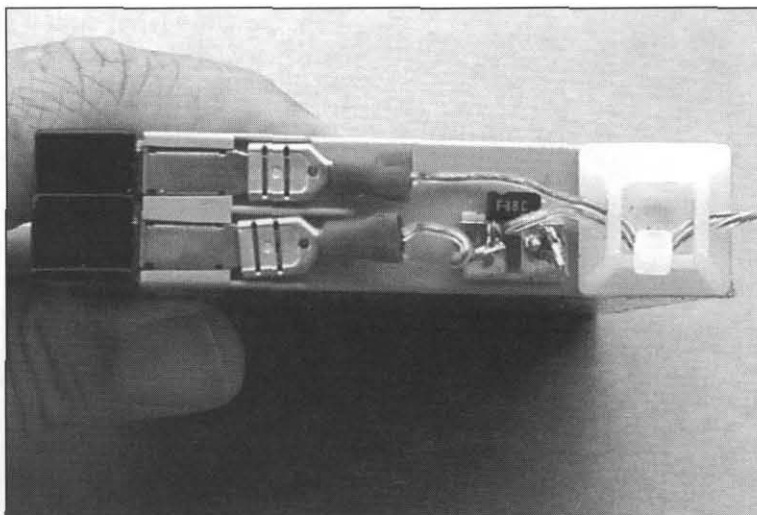

Figure 4—Top of battery with quick-disconnect connectors and solid-state fuse mounted on piece of PCB material.

rent. Many battery pack manufacturers build them into their products to prevent failure if the pack is short-circuited.

The battery terminals and other exposed “hot” points are insulated to prevent inadvertent shorting. This can be done in any number of ways, but duct tape is an expedient, easy to remove (though not very elegant) solution.

The cable is firmly connected mechanically to the battery pack to keep it from being inadvertently yanked off when it (inevitably) falls off the edge of your operating position.

The second version was built into the same belt-clip pack as the first. However a local Radio Shack was having a clearance sale, and I found several old-style cell phone pouches with a little more internal room. This extra room allows storage space for adapter cables. Since it was in a clearance sale bin, it cost only \$1.00. Now that warmed the cockles of my frugal heart!

The circuit is utter simplicity (Figure 2) and indicates the detail described above. The battery terminal lugs were from an assortment (RS 64-4039). Radio Shack and others carry a variety of them. They are crimp lugs which provide a solid mechanical connection with an insulated barrel to prevent accidental short circuits.

The so-called solid-state fuse is a relatively new device. It will supply a current of several amps continuously. Made by several manufacturers, they are positive current thermistors with a normal resistance of a fraction of an ohm. When current through them exceeds their rated

value, they rapidly heat up and go to a high-resistance state until current is removed.

I have used several types, depending on which I could get my hands on. DigiKey carries the TYCO/Raychem line called Resettable Devices—inventive name, that! The Raychem LTP190 measures about 0.4 inches square and .04 inches thick, with solderable tabs at each end. It will run all day at 1.9 amps with a series resistance of only .057 ohms, but it goes into its high-resistance state above 4.2 amps. DigiKey currently carries them for about 70 cents in small quantities.

For the power pack described in this Quickie, I did not want to make a special DigiKey order, so I found an NTE functional replacement locally. Dubbed the NTE15009E, it has a maximum rated current of 1.5A and an internal resistance of .042 ohms. Two dollars for two of them beat spending the \$25 or more of my usual DigiKey order.

By the way, these resettable devices or solid-state fuses or whatever you call them are good replacements for common fuses in QRP gear. My Quickie #2, back in the Jan, 1991 *QRP Quarterly*, was on Dummy Diodes. I recommended a transient suppressor diode on equipment DC power lines and a series diode. As pointed out at Atlanticon 2002 by my friend Jim Kortge, K8IQY, a more modern protection circuit uses a solid state fuse and a common 15V 1W zener diode. It automatically provides overvoltage and reverse voltage protection. This circuit is so inexpensive and simple that it is worth adding to all of your

QRP rigs. And if you jack up the supply voltage to get more power out, remember to use a higher voltage zener diode! Figure 3 shows the revised circuit.

Now back to the battery pack! As you can see in Figure 4, construction is straightforward. The power cable is a couple of feet of light-gauge speaker cable with one end terminated in a coaxial power jack. The cable is passed through a cable tie hold-down that has sticky-backed foam tape to hold it secure. A tie wrap secures the cable to the hold-down. At the other end of the cable, the negative lead is crimped onto a lug which connects to the “-” side of the battery.

The positive lead is soldered to a scrap of PC board stock that is about 1/2 inch square. This is divided into two insulated sections with a hacksaw through the copper foil. The solid-state fuse is soldered across the gap and a short wire is soldered to the “hot” side and connected to the battery with a female clip as with the negative lead. The PC board scrap is held in place on the battery end using double-sided foam tape.

Not shown in the photo is the hi-tech insulation that covers the whole thing—I just use duct tape over the whole end of the battery to prevent shorts!

Earlier I mentioned that I use a coaxial power jack on the power cable and a double plug cable to connect to my QRP rigs. This is my solution to the age-old dilemma we all face with power connectors. It really is driven in my case by how I charge the gel cell. Under normal conditions, I use a “13.8” volt wall wart that supplies a charg-

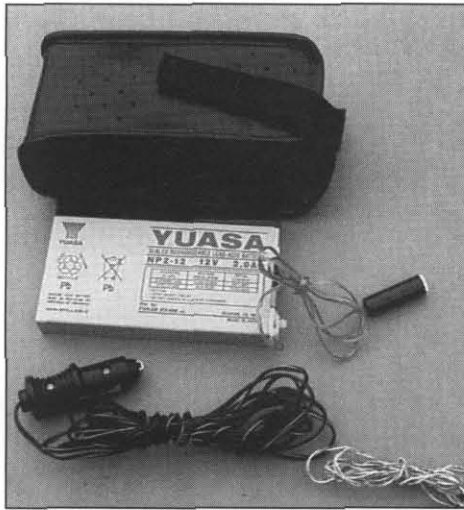

**Figure 5—The finished product.**

ing current of about 150 mA. This is just below the C/10 charging current I normally use and is very convenient. Furthermore, the wall wart cable terminates in a coaxial power plug. Other charging schemes I use are a 100-150 mA solar panel and my 12V automobile power system. Connection to either is through a so-called cigar lighter plug with a cable that ends with a—you guessed it—coaxial power plug.

Figure 5 is a photo of the entire ensemble. The cheap Radio Shack belt-loop pouch at the top can hold the battery pack plus both of the adaptor cables. The cigar lighter cable is at the center of the photo and the homebrew double-plug cable is at bottom right.

This year I'm looking for a 4 A-H or larger gel-cell battery for more power!

—de N2CX

n2cx@voicenet.com

### Testimonial for the WA8MCQ BNC Repair Tool

I got e-mail from Preston Douglas, WJ2V, a while back, saying that he wanted to borrow the homemade "Smashed BNC Socket Restoration Tool" that I described in this column a few issues back. He had damaged one of the input connectors on his Tektronix 465 scope and wanted to try restoring it rather than take everything apart to replace it. I mailed it to him, it did the trick, and his scope was back in use.

A tool like this can't fix BNC connectors that have been severely damaged, and there is always some risk of destroying the connector in the process. However, it can

restore a lot of them if not too badly damaged and it's used with care. And even if the connector doesn't survive the attempt, you're no worse off since it had to be replaced anyhow.

I'm sure a lot of other QRPers have made simple special purpose tools that were not available commercially or were too expensive. If you've done it, send me some details and I'll share them.

### NE602 Not Gone for Good, Part 2

As I mentioned in the last issue, a while back it was believed that the NE602 was both obsolete and no longer available. I said that Paul Harden, NA5N, had some QRP-L and GQRP-L posts about the history of the problems with getting this chip, and that I'd present a compilation later. Here it is, taken from three posts that I could find, as far back as August 2000. (There was at least one before that.) These are mostly his words, although I've shuffled things around a bit and had him check it over first to be sure I didn't mangle things too much.

*Please note that Paul has a new e-mail address: na5n@zianet.com*

The NE602 is in fact obsolete, and has been for years. It was the original IC mixer designed and produced by Signetics, a company now long gone. The NE602 is obsolete by number designation only, but still alive and well and available as the NE612 or SA612 (The NE612 is the plastic IC version and therefore cheaper than the ceramic SA612. The NE612AN indicates the thru-hole version).

The ever-famous chips are manufactured in the Philips Semiconductor plant in Albuquerque, about 85 miles north of me. I visited there and had a nice discussion with an applications engineer about the history of the NE602's. They were quite shocked to learn of the widespread usage of NE602/NE612's by hams/QRPers, a market for these mixer chips they were unaware of. They claim there are no immediate plans to discontinue making the NE612's. They do tend to wait until the worldwide stock gets very low before making more, as they don't like to tool up for an IC without making several tens of thousands at a time. This long story will prove that NE602 = SA602 = NE612 = SA612.

The original NE602 was designed/manufactured by Signetics for the 45 MHz

FM wireless telephone market. A little later, the wafer was redesigned a bit to allow the internal oscillator to operate to 200 MHz and the RF to 500 MHz. This was re-designated the NE612, and was intended to replace the NE602. However, customers kept ordering the NE602, getting angry at Signetics because their distributors were out of stock, etc. So when they made the chips, they made a jillion NE612s, and labeled some of them NE612 and the rest NE602 to satisfy the users of both parts. This is why contemporary data books show the exact same specifications for both NE602 and NE612. They came from the same wafer.

Signetics was bought out by Philips, who evidently continued this practice for a short time, then decided it was rather redundant. They announced that the production of NE602s had been discontinued and listed it as an obsolete part, giving QRPers around the world various fits of apoplexy and suicidal tendencies, feeling that doomsday had struck. What wasn't well understood is that Philips continued to support production of the NE612, as they do today.

Then to make matters worse, disaster struck the Philips plant in Albuquerque in the spring of 2000. A wild grass fire in northwest New Mexico threatened three main electrical lines that run from the "Four Corners" electrical generating plant to Albuquerque. Smoke from the fire caused one of the high-voltage lines to arc, tripping the circuit offline. Virtually the entire electrical load for Albuquerque and southern New Mexico was now transferred to the two remaining feeders, which could not handle the full load, causing brownouts, voltage spikes, etc. until they, too, failed.

Where I live in Socorro, New Mexico, I remember the brownouts hit about 4:15 PM, outages on and off until the entire grid went down about 5 PM, and stayed off until about 11 PM. It was one of the longest power failures in US history. We just figured it was Y2K about 3 months late. (PS—I worked 40M CW QRP that night by candlelight, and it was the quietest conditions I ever heard on 40M!!! And every QSO I heard seemed to be a QRPper).

The extreme voltage fluctuations as the feeders were failing caused a transformer at the Philips plant in Albuquerque to catch on fire. I remember seeing it on the TV

news, in which they said it caused mostly smoke damage from the burning transformer and burned a couple of storage rooms. At first the damage was considered to be minor. However, it was soon learned that the smoke and water contaminated all of the IC fabrication "clean rooms" and equipment, and caused heat damage to the room where the IC film masters were stored.

This means some of the very touchy negatives used for making the dies had to be redone. The NE612 film master was now molten emulsion. These film masters were the originals from the old Signetics company. And all of the clean rooms and die-making machinery had to be cleaned and refurbished to ensure that no contamination would occur in the IC fabrication process.

Philips had to completely redo the artwork for the majority of their ICs. They were basically unable to manufacture ICs at the Albuquerque plant for months. It was about 8 months before they got all their wafer machines back on line, which left a huge hole in the semiconductor industry. I know it just about killed several cell phone manufacturers because delivery contracts for parts were suddenly postponed for six to eight months.

The first production to get back on line was the larger scale 20 mm dies (for the large multi-pin ICs used in cell phones, etc.), then the 10 mm, and finally the 5 mm die production (which the NE/SA 602/612s fall under) became operational in late July. Philips Semiconductor announced that the Albuquerque plant was again 100% operational and running at 100% capacity.

According to an article in early August in the *Albuquerque Journal*, Philips was running at 100% capacity before the fire, followed by many months of limited capacity following it. So now that they were at full IC production again, they were woefully behind in their production schedules, for which some of their ICs will end up being manufactured over a year late. The world supply of SA612ANs (the thru-hole version) was nearly exhausted at their distributors in the fall of 1999, producing a known shortage, and they were not due for production until September 2000. [*The SA612 is essentially the same as the NE612 but with a wider temperature range.* —WA8MCQ]

The worldwide supply of NE602/NE612s virtually dried up during 2000 as a result of this fire and the nearly year backlog of manufacturing quotas. The first run of NE612s in 2 years finally occurred in September 2000. This huge shortage of NE612s, combined with the fact that NE602s have been discontinued/obsolete, is what convinced QRPer that these nifty little chips were no more. I was told that 20,000 units were manufactured in 2000, or what Philips believes is a 2 year supply. This is also why the release of the Elecraft K1 (with 5 NE612s!) was delayed from the promised "after Dayton" to late in the year, as were other kits. It just wasn't clear when Philips was going to schedule the NE612s for production.

So yes, the NE602 is dead, but the perfectly compatible NE612 and SA612 are still available, and Philips has no plans at the present to discontinue them.

For final clarification:

NE602 = plastic DIP, rated 0C to +70C  
OBSOLETE

SA602 = plastic DIP, rated -40C to +85C  
OBSOLETE

NE612 = plastic DIP, rated 0C to +70C  
AVAILABLE

SA612 = plastic DIP, rated -40C to +85C  
AVAILABLE

For our QRP purposes, the NE612 is EXACTLY the same as the NE602. NE612s are still being made, still available from most vendors, is not obsolete, and should be available for several years yet to come. If a vendor tells you the NE602 is obsolete, then have him check on the NE612. If he claims those are obsolete also, it just means they do not carry them.

—de NA5N  
na5n@zianet.com

### KD1JV Frequency Counter Mod

Some time ago Steve "Melt Solder" Weber, KD1JV, put out a limited edition frequency counter kit. Monte Northrup, N5FC posted this fix for it to QRP-L. By the way, Monte has an excellent web page with all sorts of homebrew goodies, some of which have appeared in the QRP Quarterly. I highly recommend that you check it out. The URL is:

<http://www.io.com/~n5fc>

As a matter of fact, the page even describes how he installed the KD1JV counter in his TenTec Century 21. Here's what he had to say about a problem with the counter—

I built the frequency counter kit and installed it as a digital dial in my old analog Century 21, and it is currently working very well. However, I want to tell you about a problem I encountered, and my fix for it. I suspect some others may encounter the same problem.

When I first installed the counter and attached it to my VFO (the Century 21 VFO tunes 5- 5.5 MHz), it seemed to count it quite nicely; however, the SW2 "DISPLAY-SHIFT" switch was exhibiting some strange behavior.

After power-on, it displayed as expected in the xxx.x kHz mode. When I pressed it to change the display to xx.xx MHz mode, it went to '8888' for about a second, then displayed the xx.xx MHz mode for even a shorter fraction of a second (impossible to read), then returned to the xxx.x kHz mode. Every once in a great while (1 of 100 button presses), it would behave normally, moving to the xx.xx MHz mode when I released SW2, then staying there until I pressed it again.

Further, it was impossible to move it into the IF OFFSET modes using SW2. The manual states that if you depress SW2 for 5 seconds or more, it will move to the IF\_A OFFSET mode. But no matter how long SW2 remained depressed, it stayed in the XXX.X kHz mode.

I checked the voltage directly on U1 pin 2 (where pushbutton SW2 connects) while pressing the switch: 4.89 VDC when un-pressed, 0V when pressed. Also, I measured the resistance from U1-2 to ground (with power off): 4.9M with SW2 un-pressed, 0.3 ohms pressed. All as I would expect. Thinking C1 might be bad, I patched a 0.1  $\mu$ F cap from ground directly to U1-2. No difference. Thinking there might be a short from U1-1 to U1-2 (causing a reset), I measured resistance between those two pins. It measured 5 Meg.

Then I noticed that the pin serving SW2 (pin 2) is right next to the microcontroller's RESET pin (pin 1). I also noticed that the RESET pin had no external pull-up resistor. Hmm...An examination of the AT90S2313 data sheet indicated that the RESET pin has an internal pull-up of somewhere between 100-600k. Mine mea-

sured 620K. Also, the data sheet stated that a reset can be initiated by a pulse of only 50 nS (or shorter). Given the high input impedance of the RESET pin and the narrow pulse required to initiate a reset, I wondered if the pushbutton's pulse might be coupling into the reset circuit.

I placed a 0.01  $\mu$ F capacitor from socket U1-1 (RESET) to a nearby ground. Voila! It all works as expected now.

The frequency counter works nicely as a display for the Century 21, and tracks my commercial frequency counter nicely all the way across the bands. Since the heterodyne oscillators in the C21 used untrimmed crystals, some bands were off by as much as 2.5 kHz. However, by noting the lower band edge "000.00 kHz" during transmit into a dummy load, and applying the SW2 IF offset per the instructions, I was able to construct a table of values, by band, for calibrating the frequency counter upon power on, or after a band-change. I simply clear the counter to raw-count mode, move to the calibration value (from my table), press SW2 until I enter the correct IF OFFSET mode (Mode C for 80 and 40 meters, Mode B for 20-10 meters), and PRESTO! My digital display is correct!

Thanks for a great kit! It's just what I needed!

—de N5FC  
n5fc@io.com

### Overtone Operation with the NE602/612

One of the regulars on QRP-L, Leon Heller, G1HSM, asked if anyone had been able to get an oscillator with the NE602/612 to work with a 3rd overtone crystal. He said that he was using a 50.15 MHz crystal in a simple receiver but it only wanted to oscillate at the fundamental, even with a tunable series resonant trap

tuned to the fundamental.

Mike Branca, W3IRZ (w3irz@att.net) had this reply—

The NE-602 works very well as an overtone oscillator but the circuit looks a little unconventional. We ran into this problem with the Georgia Sierra (Sierra from the ARRL handbook that was re-frequenced to use all computer crystals) when making the radio work on 10 and 6 meters.

The oscillator section of the NE-602 could be compared to a grounded collector transistor oscillator, assuming that the transistor is an NPN and a bypass capacitor on the collector, and that pin 6 is the base and pin 7 is the emitter. For the '602, connect the crystal from pin 6 to ground as usual. Then use the usual capacitive divider of 27 pf from pin 6 to pin 7 and 68 pF from pin 7 to ground.

Now for the new stuff, shown in Figure 6: at pin 7, connect a 0.01  $\mu$ F cap. Wire the other side of it to the new parallel connected coil and trimmer that will resonate at the desired overtone frequency. Ground the other side of the new coil and trimmer. Works like a charm.

[Leon later replied that it worked like a charm.]

—de Mike, W3IRZ

### Improved Signal Isolation for MFJ Coax Switch

Sam Billingsley, AE4GX of the North Georgia QRP Club, posted this fix for an MFJ antenna switch to QRP-L—

My trusty old MFJ coax switch is a Model 1700B and I've had it for years. (See Figure 7.) There may be a later model with these fixes incorporated.

The enclosure has two switches of six positions each for connecting up to 6 rigs

and 6 antennas. The box is about 10" wide, 3" high and 1.5" deep so the coax connectors and the switches are in close proximity.

Internally, the wires are unshielded, and runs are made from the coax connector center pin to the switch locations. In some positions these runs are up to 8" in length.

Even though the unused rig and antenna positions are grounded to the enclosure by the switches, there are some positions that have 8" wires in parallel with similar runs on the other switch. Hence there is a lot of mutual coupling. In fact, with strong receive signals on one antenna, you can actually hear the signal (down in strength of course) on another RX position even though it's technically grounded. Figure 8 gives the basic idea of the layout.

As the first step to improve the situation, I replaced the unshielded wire for the common switch positions with coax and grounded the common coax connector end to the enclosure. Figure 9 shows the result.

I also noted that two of the positions of each switch are very close to their respective connectors, with the shortest wires, so these should be used first. The connectors having longer wire runs should be used less frequently.

This simple change greatly improved the signal isolation between rigs and antennas.

See the following link for color pictures of the switch and mod:

<http://www.qsl.net/ae4gx/MFJCoaxswmod.html>

[Sam later had some additional comments on the NoGA QRP mail reflector]—

I only grounded the coax at the connector end. I stripped back the shield a bit

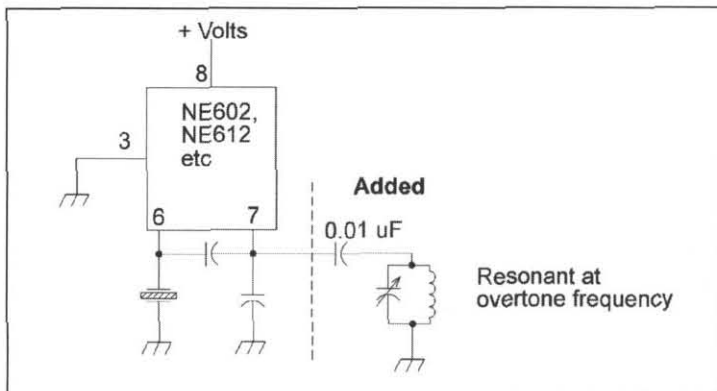
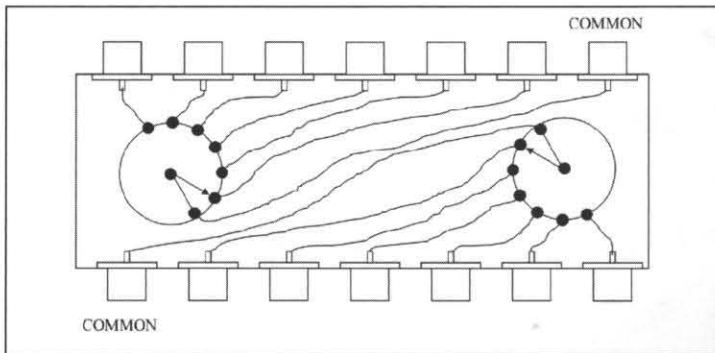

Figure 6—Adding a tuned circuit resonant at the operating frequency allows use of overtone crystals with the NE602/612.



Figure 7—The MFJ antenna switch.



**Figure 8—WA8MCQ drawing (not to scale) gives the basic layout of the MFJ antenna switch. Not shown here, all wires are grounded at the switches except the ones selected. Long runs of wire lead to signal coupling, even when grounded.**

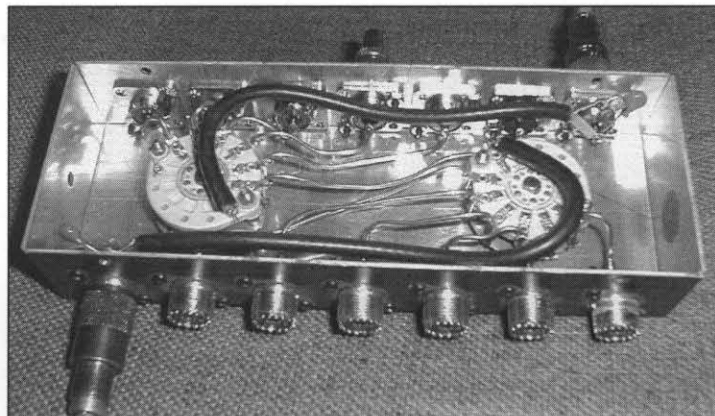

**Figure 9—The modified antenna switch. (This photo is also on the web site.)**

from the other end, cut it off and then taped it to prevent a possible accidental short.

I had read about potential ground loop problems but thought that in this small box it wouldn't matter. The real reason was that on the switch end there was no nearby location to solder the shield to a grounded spot.

This isn't a milled, sectionalized coax switch, so I'm not expecting that level of isolation.

I don't claim originality for this modification. I vaguely remember reading about it somewhere, probably Hints and Kinks in *QST*. I was just trying to pass on a little improvement.

You could, of course, put shielded coax on all runs but I didn't think I needed it.

There is one more additional simple mod that you could make. The bare wire runs from the connectors to the switches are almost in parallel between the switches. You could add a metal shield (aluminum or PCB material) between the longest two runs. This would shield the two basic sections from all direct leakage between them. Make sure you don't short one of the bare wires to the shield if you do this.

The antennas positions are numbered 1 to 6, with 6 being the shortest wire from the switch to the coax connector. The rig side are letters from "A" to "F," with "F" the shortest to the switch from it's connector.

So, if you only have a couple of antennas and rigs normally connected, use 6 first then 5, etc., for the antennas, and F first then E, etc., for the rigs. This will insure that the bare wires used the most are the shortest. (The last two positions on the

switches are so close to the switch that it would be useless to put coax on them anyway.)

—de AE4GX  
sambillingsley@earthlink.net

### Micro Moments #1: An Intelligent Controller for your Rig

George Heron, N2APB, guiding light of the NJ QRP group and member of the QRP Hall of Fame, offered to supply a number of short pieces for the Idea Exchange. But don't worry about him dropping his column. Just like N2CX who keeps up his Quickies even after he started

a column, this isn't replacing George's, just supplementing it. You can contact George at n2apb@amsat.org. Here's his first installment—

This is the first of many short pieces concerning ideas, experiments and projects relating to use of microcontrollers in ham radio applications. One's technical toolbox today is burgeoning with the many different processors and techniques, and this ongoing segment in the Idea Exchange column will attempt to sort them out and perhaps plant the seed for your own scathingly brilliant next project.

To illustrate how simple a microcon-

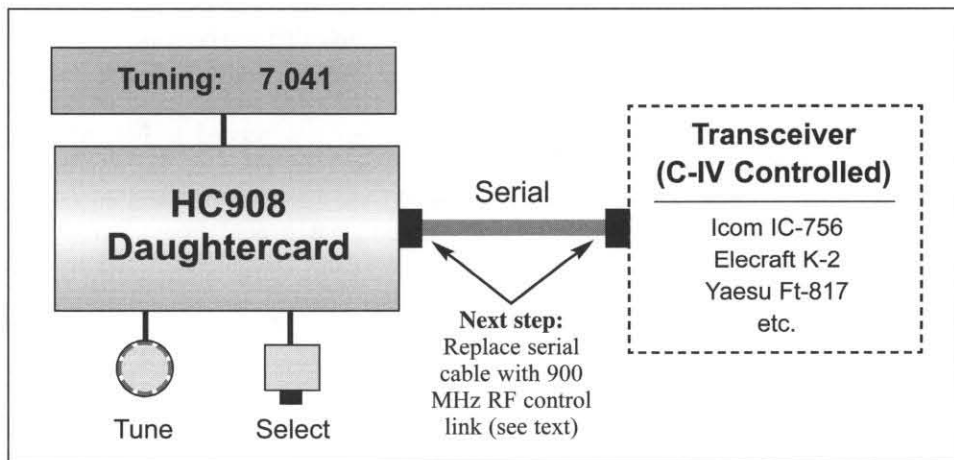

**Figure 10—Block diagram: The Intelligent controller delivers serial data to the auxiliary control port of popular transceivers, thus commanding them to change mode, change frequency, start scan, etc., just as would be done manually by the operator using front panel controls. The software program in the HC908 Daughtercard microcontroller accepts the "tune" shaft encoder and "select" push-button inputs from the operator and commands the requested action to the transceiver. The LCD displays status information about the transceiver and prompts the operator for required actions. The serial cable connecting the Intelligent Controller and the transceiver will be replaced with a 900 MHz RF data modem in the next installment of this project, thus enabling operation without the encumbering cable connection.**

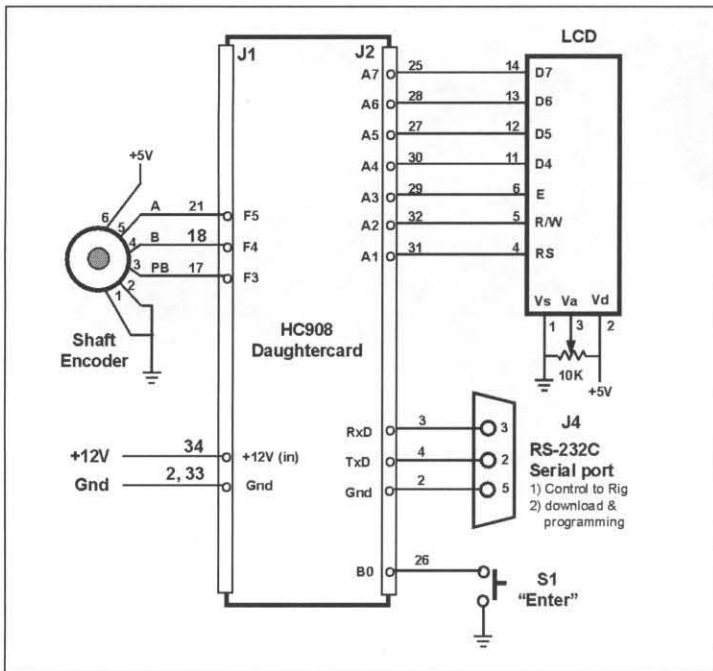

**Figure 11—Schematic.** Simple I/O devices (shaft encoder, LCD, serial port and a pushbutton) are all that's needed to allow the HC908 Daughtercard to perform as a CI-V intelligent serial controller for your rig.

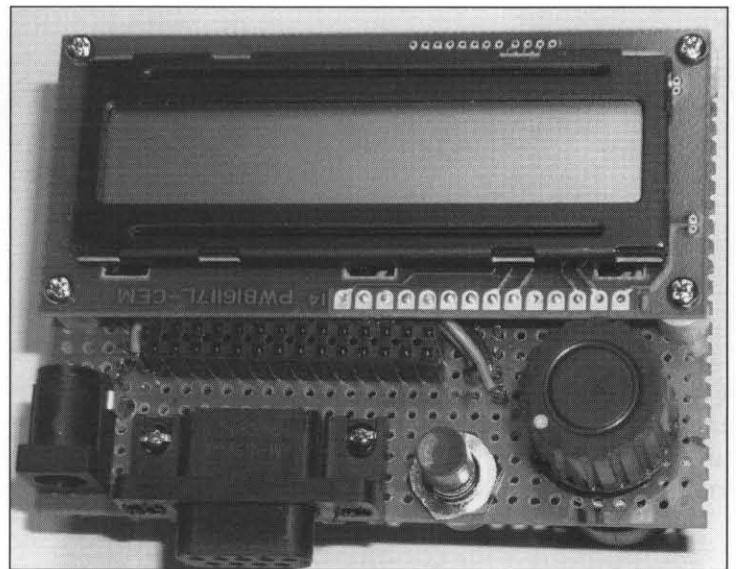

**Figure 12—Top view of Intelligent Controller.** Overall about 3" x 2" in size, the LCD is attached to a perf board that also contains: (R-L) the shaft encoder, pushbutton, DB9F RS232 connector and the 12V power jack. (The double row connector above the DB9F connector is intended for the 900 MHz data transceiver to be used as the control link, replacing the serial cable in the next installment of this project.)

troller-based project can be, I'll illustrate the design of an Intelligent Controller that can be connected to your HF transceiver AUX control port to provide remote control tuning, band changes, and essentially anything else that can normally be accomplished manually with the rig's front panel controls. Figure 10 shows the block diagram, and figure 11 is the schematic. A small hand-held unit measuring 2" x 3" x 2" contains the microcontroller, an LCD, a pushbutton and a serial connector that is used to connect to your rig's AUX jack on the back panel. Auxiliary control ports are standard now on many modern transceivers—e.g. Elecraft K2, Icom IC-706, Yaesu FT-817—and software has been developed to control each of these transceivers.

I used the HC908 Daughtercard developed in the regular Digital QRP Homebrewing column located elsewhere in these pages. If you've been following along with that column's "Digital Breadboard" project, you know that it uses the 68HC908AB32 "CISC" microcontroller which provides a rich and powerful instruction set and plentiful number of I/O ports for controlling many peripherals like LCDs, switches, etc. Digital buffs might believe that it would be simpler to use the

popular PIC microcontroller.

I chose the Motorola 'HC908 chip, however, in order to break out of the programming straight jacket that RISC processors present and to provide lots and lots of I/O bits to work with as a standard computing module that can be reused on many different projects. Further, a boot loader has been designed and no extra or expensive hardware is needed to program the HC908—all you need do is connect up your PC via the serial port and download the latest/greatest new program from the Internet to the Daughtercard and it programs itself!

Constructing the Intelligent Controller is a straight forward exercise in combining standard peripherals for the user interface and for connection to the transceiver being controlled.

The HC908 Daughtercard is a self-contained computing module that requires only 12V to operate. The oscillator, voltage regulator, and serial port RS232 drivers are all contained on the card. The homebrewer merely needs to wire the LCD display device, a shaft encoder, a pushbutton and a DB9F serial jack to the respective J1 or J2 connector pins on the Daughtercard.

Construction of my initial unit was

complete in less than 60 minutes. Making up a cable to connect your rig might take a little more time, as each transceiver's AUX port is different—see your radio's manual for correct pinout. Add another two minutes for downloading/programming the HC908, and you'll be in business.

The software program contained in the Intelligent Controller is menu driven and pushbutton selected. Based on the relatively standard Communications Interface protocol, version 5 (CI-V), the program displays the radio's various controllable functions (e.g., frequency, band, filter, antenna, etc.) when the operator turns the shaft encoder. Once a desired function is dialed up, say "frequency tune," the Select pushbutton is pressed and the software presents the dial frequency on the LCD, allowing the operator to tune the radio much as if it were being done at the rig's front panel controls. See the full list of controllable functions listed in the appendix of your radio's manual, or you could do an Internet search on "CI-V" to find tons of information concerning the functions supported by different vendors.

Okay, so let's now address the big question...why one would want to have such a remote controller device for a transceiver? Besides the obvious answer



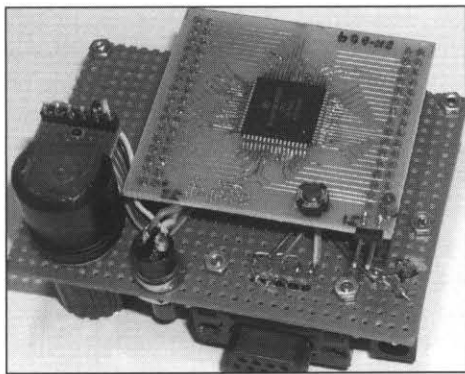

**Figure 13—Bottom view of Intelligent Controller. The “brains” of the project is the HC908 Daughtercard, plugged into the dual 34-position pin headers on the perf board. This modular and flexible microcontroller is the basis of the ongoing project described in the Digital QRP Homebrewing column in each issue of *QRP Quarterly*. The 68HC908AB32 microcontroller doesn't need any specialized or expensive programming hardware—just download the program from your PC and you're off and running with a new project!**

that any homebrewer would give “Because it can be done,” there are indeed several legitimate reasons that a gadgeteer ham would want a device such as the Intelligent Controller.

Customization of radio functions can easily be done. For example, one could establish a set of memory channels or preferred configuration settings that are unique to the individual operator(s), time of day or operating mode (contesting, rag chew, DXing). At the touch of a button, these settings could place the radio in a pre-defined condition.

The Intelligent Controller also presents a common interface to multiple radios, thus allowing easy transition from rig-to-rig in the shack with minimal shifting of mental gears. For example, I own several Icom radios, and this Intelligent Controller conveniently handles each of them. If I wanted to bring a different vendor's radio into the fold, I would merely dial up a different menu item on the display to select the vendor-specific set of options on, say, a Kenwood UHF rig, and I'd be in business.

A follow-on to this project will eliminate the physical connection of the serial cable going to the rig being controlled. A small, 900 MHz RF data modem card will

be plugged into a connector already present on the prototype unit, shown just above the DB9F in Figure 12. (Figure 13 shows the other side of the unit). This wireless control link will communicate with a small box plugged into the AUX connector of each radio to be controlled, thus enabling the operator to roam about the immediate area and operate the rig without being tethered by a serial cable. This feature enables quick and easy change from one rig to the next, while reducing the number of cables on the bench.

I hope I've illustrated how easy it can be to build up and use a microcontroller for use in the shack. In future Micro Moments, I'll describe approaches to simple micro-controlled test equipment and tie in some of Joe (N2CX) Everhart's techniques described in his regular TTAM column...after all, synergy makes the world go 'round!

#### NOTES:

1) Complete and detailed background, software listings and guidance for constructing the Intelligent Controller are available online at [www.njqrp.org/digital-homebrewing](http://www.njqrp.org/digital-homebrewing). Just look for this project on the left side of the page.

2) The Intelligent Controller is not being offered as a kit by the NJQRP, but the HC908 Daughtercard itself is indeed available for purchase. You'll find this computing module convenient for many custom projects.

—George Heron, N2APB  
2419 Feather Mae Court  
Forest Hill, MD 21050  
Email: [n2apb@amsat.org](mailto:n2apb@amsat.org)

#### Homebrewed Open-Wire Feedline

Posted to QRP-L by Charles Moizeau, W2SH—

I decided to undertake ladder construction because of my utter dissatisfaction with what is commercially available. A dozen years ago at a hamfest I bought some #14 enameled solid copper with 5/16" diameter polystyrene spacers heat fused to the wire. The seller said that it was commercially made and had been stored for years in his attic. I had never seen this feedline before or since. I was only able to buy his 75-foot roll, but it worked out well. Twenty or thirty years ago, there was sold solid copper wire feedline with white plastic insulators about 1 1/4" long and 3/16"

diameter. This was crap. The enamel insulation and the spacers both cracked after a few months outside.

I presently require a 180-foot long feedline. I got some solid #14 enameled wire manufactured by Phelps Dodge, but the insulation didn't hold up. Varnishing the wire with \$23-a-quart marine varnish didn't work for very long. What is now showing great promise is bare solid copper wire with three coats of rust proof paint. This paint is latex based, and has worked beautifully for me painting iron railings and anything metal that lives outside.

I remember as a kid seeing open-wire feedlines with wax-impregnated wooden dowel spreaders. If it worked for the OTs, well why not for me? I combed through *QST* for the 1920s and 1930s. I noted, (but unfortunately ignored), a couple of comments saying that such spreaders didn't hold up very long. Somewhere else I read that a mix of two parts beeswax to one part paraffin was what was best.

I have long respected bamboo as having a very high strength-to-weight ratio. I also like to eat Chinese food. So, you guessed it, I started pocketing my eating instruments after the meal, much to the amusement of the waiters. At any Chinese grocery bamboo chopsticks are available in a variety of shapes and sizes, as cheaply as 500 for seven bucks. I bought a bunch. I sized their diameters with a drill bit gauge and eyeballed them for straightness. I discarded nearly half of the lot. I cut the keepers to two-inch lengths, and drilled and notched their ends.

I baked about two hundred of these spreaders in a 180-degree F. oven for 24 hours to drive out any moisture. Then they were cooked in the wax mixture for half an hour. The first batch cooked at too high a temperature and came out dark brown. I then got a candy thermometer and limited the wax temperature to 180 degrees F. (Paraffin melts at about 110 degrees F. and beeswax at slightly less). Wax is inflammable, so I used a large high-sided stock pot and was careful [*editors note: wax should always be melted in a double-boiler for safety reasons*]. I kept peace in the family by really cleaning up the kitchen afterwards. I mounted the spreaders to the paralleled conductors stretched between two trees. Eschewing metallic ties, I used braided Dacron 50-lb. test kite line to lash the spreader to the wire with a

constrictor knot. I left the feedline out all winter. The bamboo spreaders and kite line ties both held up, but the wax impregnation on the spreaders and the varnished enamel insulation on the wire did not survive very well.

The newest batch of bamboo spreaders was baked dry for 24 hours, then dunked in hot linseed oil thinned with paint thinner. When dry, they were dunked four times in the expensive marine varnish with two days' drying time between dunkings. They've held up well outside this winter, as has the painted wire.

Now it remains to construct the feedline by putting the two together. The wax mixture in the stock pot has been used most successfully to impregnate my rope halyards.

The brief moral to this long story: those two guys who wrote to *QST* 65-70 years ago were right—wax impregnated spreaders don't last a long time. Have I done the right things? Certainly not all of them. But I've learned a lot, and bamboo is a lot cheaper than Teflon® rod.

—de W2SH  
W2SH@aol.com

### Source of Ceramic Spreaders

William Colbert, W5XE, replied with this—

For those still interested in the ceramic type spreaders, Daburn Electronics and Cable still has all sorts of ceramic type insulators, including the 2 inch spreader types for making open wire feeders. They also make a very nice dipole-type insulator which has a top section for rope or wire attachment away from the radiating wire holes. Very strong—used one to support a 300 ft. vee beam. Additionally, Daburn has lots of antenna type wire, actually wire of all types. Haven't ordered anything in recent times, so don't know if they are cost effective, but their catalog is on line at:

<http://www.daburn.com/~daburn/home.html>

My *E&E Handbook* 1946 edition and the *E&E Antenna Handbook* both make reference to 300 ohm line. And in my 1947 *ARRL Handbook*, American Phenolic shows an ad for 72, 150 and 300 ohm twin lead. They also had a replacement polystyrene windowpane ready to drill and

replace a glass pane near the operating position.

—de W5XE  
W5xe@juno.com

### Open Wire and Spreaders, A Cynic's View

Finally, here's an opposing viewpoint on this sort of thing. Actually, this was posted to QRP-L a day before the ones above. This is from James "Doctor Megacycle" Duffey, KK6MC—

After several go-arounds with home-made open wire line, I have decided that given the relatively low cost, and in my application reasonable performance, of the "450 ohm" ladder line, open wire line is not worth the effort.

I have made the open wire line from hard drawn wire, enameled magnetic wire, and some hookup wire in gauges ranging from 14 to 22. The size and type of wire you use doesn't make much difference.

Good spreader materials are hard to find. Plastics designed to be used indoors generally depolymerize rather quickly outside, at least at my altitude (7000 ft). This includes the plastic coat hangers, hair curlers, and theme paper binders. I had the best luck with the gray PVC pipe made for electrical conduit. This does make rather heavy feedline though. You can also buy UV resistant plastic stock, either round or square, to make your own.

It is hard to place the spacers evenly without introducing twist in the line. It is best to keep the open wire line under tension when being used.

In practice, open wire line, as well as the modern ladder line, will not exhibit the

low loss often quoted. Dust, pollution, wind, and moisture all conspire to increase loss. Nonetheless, either open wire line or ladder line will have lower losses than commonly used coax such as RG-213 or RG-58. Until it rains. Then the ladder line and open wire line will both exhibit increased losses, but the ladder line will be worse. New Mexico is rather dry, so those days when it rains or snows are few and far between. If I lived in the Northwest, or Southeast, I am sure that I would have a different opinion.

Both coax and ladder line have their advantages and disadvantages. I usually replace one with the other when I am changing antenna systems.

—de Dr. Megacycle, KK6MC/5  
jamesd1@flash.net

### Two PCB Paddles

Steve "Melt Solder" Weber, KD1JV of Berlin, NH, is well known on QRP-L for his technical insights, design prowess, and string of limited edition QRP kits. His web page is at [www.qsl.net/kd1jv](http://www.qsl.net/kd1jv) and has some of his projects. Here are two of them:

#### 1. Lightweight PCB Paddle, 0.8 oz.

I decided to make a small, lightweight paddle out of some scrap PCB material, instead of buying something pre-made. The results surprised me. The paddle is very responsive and easy to use. In fact, I like the feel better than a fancy, expensive paddle I own.

The paddle is made from two different thicknesses of double sided printed circuit material. The arms and base are made from 0.032" stock, and the paddle arm support

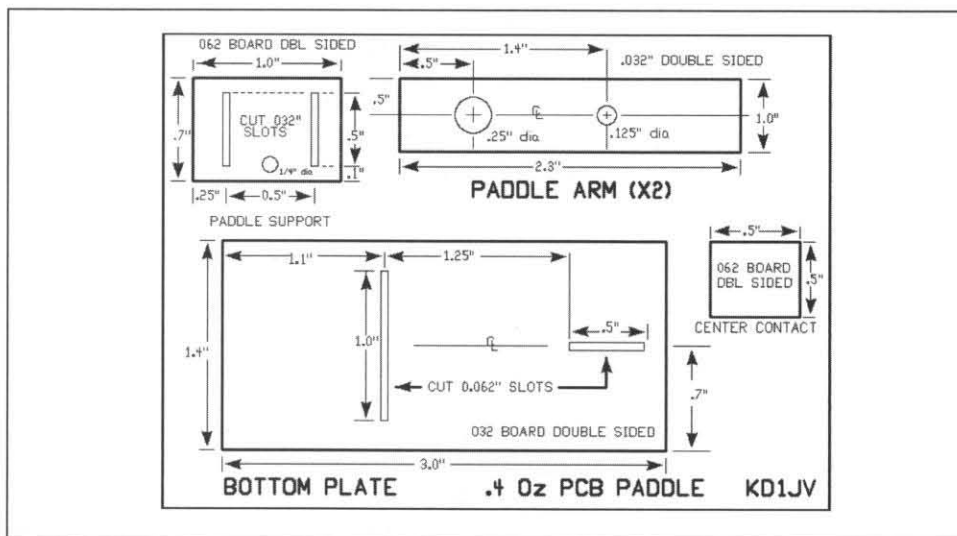
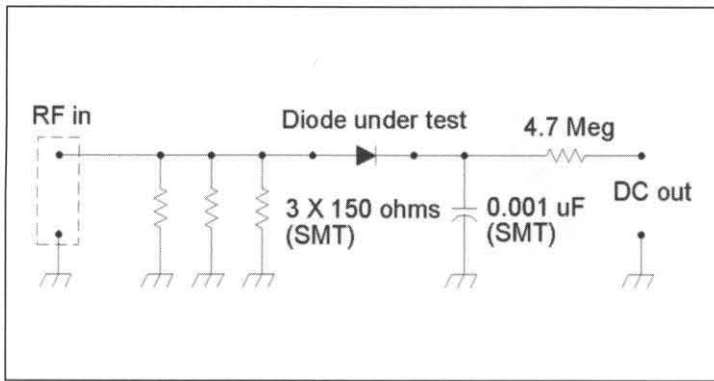

Figure 14—Dimensions for the parts of the KD1JV PCB paddle.





**Figure 19**—Schematic of the diode test fixture. By the time I was done, I had 18 identical circuits built with surface mount parts on 2 pieces of scrap PCB stock. The PCB pads were milled out and are identical at all 18 positions.

### More on Diode Detector Response

I ended up testing the frequency response of several more diodes since the last issue but ran out of time to do a detailed report. For now, I'll give a few of the highlights, including the most important observation, the different responses of three groups of diodes: small signal germanium and Schottky diodes, small signal silicon diodes, and power rectifiers, both silicon and Schottky. (I also have one small signal Schottky diode on which I deliberately degraded the frequency response to make it as poor as a Schottky rectifier.)

This started out as a quest to see what sort of frequency response Schottky rectifier diodes like the 1N5819 have when used in an RF detector circuit. As expected, the short answer is not very good at all if you're looking for accuracy up to 500 MHz, but still usable across the HF range for things that only require relative indications and not absolute accuracy. Having the name Schottky in the description of the part is not a guarantee of good performance as an RF detector. The internal capacitance can vary dramatically between a rectifier and small signal diode, and that's what makes the rectifiers poor as diode detectors if any sort of accuracy is needed.

Figure 19 shows the test circuit, which is the classic diode detector. Although it usually uses a 50 ohm input termination, I used three 150 ohm surface mount resistors in parallel due to availability. (The capacitor and 4.7M resistor are also SMT.) It's fed by a lab quality signal generator swept manually through specific frequencies from 1 to 500 MHz at a constant output level (+15 dBm), with the output of the

detector measured with a Fluke digital multimeter. My initial tests were with a Rohde & Schwarz generator, and I later switched over to an Agilent E4433B. (That's the new name for the old Hewlett Packard test equipment division.) I don't know the price range of either, except that they both fall into the category of "I don't even want to think about it."

Figure 20 is rather cluttered, but gets the basic idea across. The top set of curves are a 1N34 germanium diode and 3 different types of Schottky small signal diodes. Those include a 1N5711 in a glass package with leads, half of an HSMS2804 surface mount diode pair (Agilent, available through Allied Electronics), and another diode in a glass package with leads which is one out of a matched set of 4. The part number for the set is 5082-9496, an HP/Agilent part number that does not appear on a search of their web page and was probably a custom product. I would suspect that the individual diodes are probably similar to the well known 5082-2800. The latter is also available at Allied, but more expensive than the surface mount types.

The curves are pretty much identical, and give a good idea of how the output level of the generators vary with frequency. Note that 3 of them rise up at the 500 MHz end while one dips instead. This shows the small differences in output flatness of the two Agilent E4433B generators that were available.

The lower set of curves is from 1N4002 and 1N4007 silicon rectifier diodes, a 1N5818 Schottky power rectifier (lower voltage brother of the 1N5819)

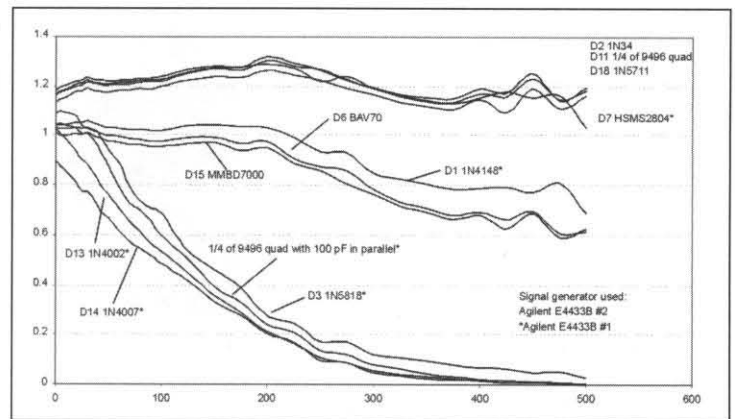

**Figure 20**—The frequency response of several diodes. Top set: germanium and small signal Schottky; middle set, small signal silicon. Bottom set, silicon and Schottky rectifiers.

and—surprise, surprise!—another of those '9496 small signal Schottky diodes. It wasn't bad; I just made it look that way. All of the rectifier diodes have relatively large internal capacitance due to their construction, and it is effectively in parallel with the diode. As frequency increases and reactance of the capacitance goes down, the diode has an ever decreasing "resistance" across it, resulting in reduced DC output.

To prove that it is the capacitance that degrades the frequency response, I connected a 100 pF surface mount capacitor across another small signal Schottky diode from the '9496 matched set. This value is on a par with the internal capacitance of the rectifiers, and the results speak for themselves.

The center set of curves was a bit of a surprise. These are from small signal silicon diodes. They include the popular 1N4148, a BAV70 and MMBD7000. The latter two are surface mount. When looking at data sheets, they have similar or even lower capacitance than the small signal Schottky diodes, and I would have expected them to have responses similar to the top set of curves. (Note that one of these diodes was done on the alternate signal generator and the dip at the 500 MHz end matches that of the diode in the top set). I expected the somewhat lower output, due to the higher voltage drop of silicon diodes, but the drop in response with increasing frequency was a distinct surprise. I have no clues here; perhaps a reader with a physics background can answer this one.

My recommendation would be to avoid

use of Schottky rectifier diodes in RF detector applications, and to be wary of small signal silicon diodes as well. That's not to say that either should be avoided completely, as they can still be useful in many applications. They should not be used if absolute accuracy is required over a wide range, such as a diode detector being used for measuring the absolute power of a signal. But they are perfectly usable for applications requiring only relative indications (ie, "tune for maximum signal," etc).

Unfortunately, when selecting diodes, you can't go by a rule such as "avoid Schottky rectifiers at all costs." In some catalogs, they lump both small signal Schottkys and what we traditionally consider rectifiers under the heading of "rectifier." In fact, when I bought the 1N5711 small signal Schottky diodes from the local Active Electronics store, the label clearly indicated that it was a Schottky rectifier. (And technically it is, just a low powered one.)

A good rule to follow is to disregard the word "rectifier" and consider both the physical size and package or junction capacitance. If it's a small glass diode or surface mount part on the order of an SOT-23 package in size (0.120' x 0.055"), it's probably safe to assume it's a small signal diode. If it's a larger surface mount part or a leaded part with black plastic body (like a 1N4002 or similar rectifier diode), then it's probably not going to be useful as an RF detector. In the data sheets, look for capacitance values on the order of 2 pF or less. If significantly above that, don't consider it for use as a detector.

In the April issue I mentioned that Allied Electronics carries many of the Agilent (HP) diodes. If you're online, you can check their web page for information and pricing. Go to [www.alliedelec.com](http://www.alliedelec.com). The quickest way to get at them is to use

the search box at the upper right of the page. Under Select Search Scope, click on "Mfr.'s part # contains" and enter HSMS in the search block (it's not case sensitive). This series is surface mount. For the leaded diodes, search on 5082. That will pull up some unrelated info since other things contain that string of numbers, but it will include the HP diodes. And remember that TR1 tacked onto the end of the part number means it's available at that price only in tape or reel with very large minimum orders. BLK is the exact same part, but sold in "bulk" with minimum orders of 1 piece and somewhat higher prices (they just snip a few parts off the reel).

In the future, I'll go into more details on my diode tests. It will include the different responses of detectors with different load resistors on the output of the diode, at 10k, 100k, 1M and 14.7M. That last one is with no load resistor on the output, being loaded down only by the 10M input impedance of a digital multimeter with the obligatory 4.7M resistor in series. (Hint—the frequency response stays the same, but the output level drops as the load resistance is decreased.)

—*de WA8MCQ*

### QRP Online

As I say every issue, there's been a huge amount of QRP info flying around the Internet for years, and it's still there!

QRP-L, which I call the "QRP Daily," is the online QRP discussion forum started in 1993 by QRP Hall of Fame member Chuck Adams, K7QO (K5FO at the time). It continues to run several dozen postings per day on a variety of topics related to QRP (and, unfortunately, many not related in the least).

QRP-F is an alternative QRP forum started by the QRP ARCI in October 1999

to take some of the load off QRP-L. The forum, QRP-F, requires a web browser such as Internet Explorer or Netscape, while QRP-L is a mail reflector and only requires an e-mail account. (If you go to the QRP-L home page, you can check out all the archived messages back to Day One).

To check out the online QRP world, go to these URLs:

QRP-L: <http://qrp.lehigh.edu/lists/qrp-l/> and you're at the home page where you can sign up, read the archives, etc.

QRP-F: go to <http://www.qrparci.org/> and click to enter the site, then click on QRP-F on the menu at the top.

And while you're on those home pages, don't forget to check out their lists of QRP related links, and at each link that you go to, check THEIR lists as well, since not all sites list all others. In addition to the QRP ARCI site, another excellent place to use as a jumping-off point for checking out QRP related sites is the NorCal home page, run by Jerry Parker WA6OWR, at <http://www.fix.net/~jparker/norcal.html>. You'll find quite a wealth of QRP info online.

### The Fine Print

There are three simple rules for this column:

1. You write and sketch.
2. I retype, edit, and redraw.
3. *QRP Quarterly* readers enjoy.

Do it any way you like; snail mail (no anthrax, please), floppies, or e-mail (no viral attachments, please). The Severn mailman and comcast.net are standing by!

●●

## **QRP Quarterly is a great place for "show-and-tell" about your construction projects!**

- Contributions for the "Idea Exchange" go to Mike C. at: [wa8mcq@comcast.net](mailto:wa8mcq@comcast.net)
- Send article ideas to Managing Editor, Mike Goins at: [mgoins@usa.net](mailto:mgoins@usa.net)
- Product reviews are handled by Larry East: [w1hue@arrl.net](mailto:w1hue@arrl.net)

# Arkiecon Report

Mike Goins—WB5YJX

mgoins@usa.net

The night before Arkiecon involves a tremendous supper (that would be “dinner” to those of you not familiar with the regionally applicable use of the term “supper”), with some 150 QRPers from all over crowded into the Rib Eye Restaurant for the annual get-to-know-the-other guys/gals-meal. This year hams from Oklahoma, Arkansas, Texas, Maine, New Mexico, California, Missouri, Iowa, Kansas, Illinois, Tennessee, Oregon, Arizona, and the United Kingdom filled two rooms, and people had to travel back and forth to say their hellos. The food was great (and the service excellent), the camaraderie even better, and it’s a heck of a way to meet people and puts names you’ve heard over the years to faces you may (or may not!) wish to see. “Turkey Fries” and “Fried Pickles” abounded, and only the least adventuresome of the group didn’t at least try one or the other. Afterwards, a group gathered in the “Breakfast Room” at the Guesthouse Inn and music (and radio talk) poured forth for all to enjoy. (Note: I could hear the music in my room, door closed, and I was two rooms away!). Doug had some “official” Arkiecon music handbooks that he shared so all could be sort of on the same page musically, and it was definitely worthwhile. He played his three-quarters size guitar, while Chuck Carpenter, W5USJ, accompanied him (or was it the other way around?) on his beautiful mountain dulcimer. JayBob’s son, Derek, was there playing guitar too, as was Nick Kennedy, WA5BDU (banjoist extraordinaire). Jerry Hall, WØPWE, graciously brought along his really well-built Manhattan-style version of the SW-30 (with modifications, of course!), and some of the fellows from up Iowa way ran some coax out the window to a hamstick. Several of us played with the rig when the loud European stations on 30 meters finally became too much to resist. Jerry might be tempted into revealing more about his rig in a later *QRP Quarterly*, as there was much interest in both it and the unique cabinet he used.

After a while (actually, sometime after 1 a.m.), everyone retired and got ready for the forums and hamfest the next morning.

There were sellers both inside and out,



**The traditional pre-Arkiecon supper was a memorable feast.**

with all kinds of gear and used parts available. I saw at least two Argonaut 515s outside (one looked nearly new!), and at least one of them left for a new home. Several other QRP rigs were also for sale used, including a mighty tempting MFJ for 30 meters that included the battery pack that I really should have taken home myself.

Things at the forums opened up on the first day with a special award being presented to Doug Hendricks from his alma-mater (Pittsburg State) followed by a letter from the president of the university praising Doug’s contributions to both radio and his field of vocation, teaching. Well deserved. No one really knows just how busy Doug actually is, and between his Norcal responsibilities, all the kitting he does, his commitments to the school, family, friends, etc., I don’t know how he does it all (I’m just glad he finds time to do the Norcal part!). Doug also made the announcement about Norcal’s latest kit project—a SWL radio with a digital read-out, combining surface mount (SMT) and regular through-hole devices, designed by Steve “Melt Solder” Weber. And it fits in an Altoids can, the regular kind, or one of WIREX’s famous (infamous?) Zomboids cans. (By the way, he has more, with or without mints, and also quality circuit boards already cut to fit this size can.)

The venerable and gracious Reverend George Dobbs, G3RJV, opened the forums on Saturday morning with a frank discussion of minimalist radios, and in doing so, he turned a new phrase that has already worked its way onto qrp-l. “Pelf,” a Celtic word, is a term he used to describe the



**There was music, too (not necessarily performed at QRP volume)!**

acquisition of that which is not really needed, and it seemingly applies to the “I-have-the-latest/greatest/most-radio-station” concept of operating. He went on to describe the “soulfulness” of radio, and how QRP radio is truly different. As always, his presentation was humorous, and right to the heart of the issue. He discussed how in the past everyone used to build, and how now is seemed that outside of the QRP community there was a sort of race to acquire all you can where things have changed from a “want” to a “need” approach—the “Pelf” he referred to earlier. He also presented a chart of signal strengths showing how a station that was 5-9 at 1 kW is still 5-3 at 250 mW, and I saw more than one newcomer or non-QRPper raise an eyebrow in surprise (some of us knew it all along!). The need for output filtering was mentioned as necessary, and we’ve all heard some low power rigs that fit into this category. Lastly, he reinforced that which we already knew about building (for better or worse!)—whenever there is a piece of homebrew gear in the station, that is what a visitor seems to gravitate toward (not the hundred-button, two-color-dial, several-thousand-dollars radio sitting behind it). Mention was made of the various G-QRP publications, and they went quickly. All are still available at [www.gqrp.com](http://www.gqrp.com).

The legendary antenna expert, Roy Lewellan, W7EL, opened some eyes with his discussion of S-units and radios and what that means in the real world. He explained the effects of SWR on antennas, asking (and answering) the questions like



**Jerry, W0PWE shows off his SW-30 (modified, of course) and accessories.**

how does it affect efficiency, impedance matching, and feedline length, and just what does some SWR ratio actually mean? The results surprised many in attendance and negated many myths that seemingly continue regarding the importance of ultra-low SWR. His gain/dB/dBi comparison was excellent and certainly changed a few minds (and antenna decisions) that morning. I think Nick, WA5BDU, best described it in his post as “we learned the black art of applying snake-oil to antenna claims.” When you can make a dipole have gain over a dipole, you know what you’re doing (right or wrong).

Graham Firth, G3MFJ, did a superb presentation on the control of the FT-817, and shared a number of step-by-step progressive interfaces he’d built. Early on he had most of us in the room when he did his “Essex girls” joke and then played his Peter Seller’s version of Cole Porter’s song, “Night and Day.” The music was performed by an orchestra, and the words were all done in

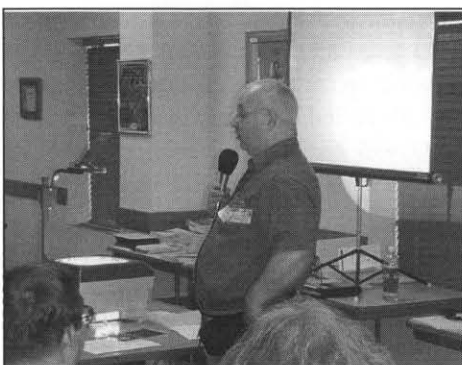

**G3MFJ, Graham Firth talked about the FT-817, with plenty of added humor.**



**This lightweight beam was demonstrated by Vern Wright, W6MMA.**

CW, complete with tone changes as needed for emphasis. Really wild!

Reverend Dobbs returned later with information on building in his presentation, “Keeping the Soldering Iron Hot!,” referring to a number of the more-or-less prominent building techniques. One test version of a circuit had the components stuck through a piece of cardboard and then wired together, while another used the “dead bug” or “ugly” style of construction. A new (at least to me) method he mentioned used a narrow woodworkers chisel to cut strips off the circuit board between component placement. (I’ve done that with a hacksaw, but had never considered the chisel and its ability to do fine lines and curves). He went on to mention Manhattan style, the use of perfboard, homemade hacksaw grids (in a checkerboard-type pattern), the use of regular etched circuit boards, and the New Jersey pad cutter. He even mentioned a small hold-down arrangement he uses to keep his hands away from the chisel when he uses it.

Roy Lewellan, W7EL, returned later to discuss Antenna Modelling Software and to ask the question, “Does that new antenna really work?”

The major aspects of his presentation had to do with not only the use of antenna



**Antenna myths and proper modeling were covered by Roy Lewellan, W7EL.**

software, but the user’s understanding of what Roy so appropriately called “garbage in, gospel out.” Good data will give you good results, while poor data will provide poor results. The only problem is that you might not realize you are getting poor results if you don’t take into account all of the factors that apply to a particular antenna. As Roy puts it, “Computers do what you tell them, not necessarily what you want, and the software follows along the same lines—it analyzes what you put in, not necessarily reality.” You tell the program the wire length, diameter, position, loads, non-radiating transmission line, etc., and the program tells you the pattern gain, front/back ratio, source impedance and SWR, load dissipation and currents. What can be modeled include yagis, dipoles, phased arrays, W8JKs, ZL Specials, Inverted Ls, Beverages, and even a Quadrifilar Helix. He closed with a discussion of antenna type, positioning and takeoff angle that was enlightening to all present. After the presentations, he spent time with those who wanted to see his software in action, and there was a crowd gathered around his laptop at the rear of the room.

While Roy was finishing up, Vern Wright, W6MMA, was putting his new multiband two element beam together and we all moved outside to have a look while the free barbecue was being setup (thanks again, JayBob!). The antenna was seriously impressive as it can switch from six meters to twenty meters (and every band in between) with a relatively simple boom and element adjustment. And did I mention it weighs something like six or seven pounds and that L.B. Cebik’s considerable antenna skills were applied to its design? It’s definitely worth checking out, and I hope to have an article on it and Cebik’s data available in *QRP Quarterly* soon.

Finally, whether you attended Arkiecon or another QRP event, don’t forget just how much trouble it is to put on such an affair. Without the likes of the individuals we have within this segment of Amateur radio, such events wouldn’t take place. An appropriate public or private email, letter or phone call would seem appropriate, and with any luck at all, these same folks will see to it that we QRPers have some place to go next year.

*The photos were taken by Henry Schneider, W5HNS—thanks!* ●●

# 20-Meter End-Fed 1/2-Wave Antenna, Tuner and SWR Indicator

Louis Hlousek, W7DZN

lhhousek@nvcbell.net

This 20-meter antenna and tuner is designed to be efficient, simple, small, and lightweight. It will work with QRP rigs up to about five watts, the main limitation being the voltage rating of the variable capacitor in the tuning circuit. An end-fed resonant 1/2-wave wire can have a feedpoint resistance of about 5000 ohms, which implies a peak voltage of 220 volts across the tank circuit at five watts. The DIP switch I used is rated at 1 amp (non-switching), and is adequate for well over 10 watts. The toroidal inductor is good for over 10 watts at typical CW duty cycles. The bridge resistors are 1/2 watt, and will be adequate for tuning at two watts and for intermittent tuning at five watts since the power is distributed among the three resistors and the antenna. Scaling up the ratings of the components would allow use at commensurately higher powers.

the current flowing into the wire is small. Even so, there must be a flow of current into the tuner to cancel it. This can be provided by a ground, a small counterpoise, or in the case of this design, the current is

tor. The capacitor is adjusted to bring the entire circuit (inductor, capacitor and antenna) into resonance, meaning its impedance is purely resistive. The tapped turns on the toroidal inductor act as a transformer converting the high resistance of the resonant circuit to 50 ohms.

Selecting among the taps provides a fairly coarse adjustment of the impedance, but often gets close enough to yield an adequately low SWR. If not, closing additional switches at higher taps effectively shorts out successive turns of the entire inductor and can be used to fine-tune the match to 50 ohms. Remember, going from tap 4 to tap 5 is a 25% change in turns ratio, but shorting one turn of the total 30 turns is only a 3.3% change.



As this photo shows, the 20-meter end-fed antenna, tuner and SWR indicator makes a small package for portable operation.

## Care and Feeding

The ends of a 1/2-wave wire are current nodes, which means the current is very low and the voltage very high. So, a resonant end-fed 1/2-wave wire will have a high feedpoint resistance. If it weren't for radiation resistance (and a small amount of wire resistance), the resonant wire would have infinite Q and infinite feedpoint resistance. Radiation resistance limits the Q and limits the feedpoint resistance of the wire to several thousand ohms. As with other antennas, thinner wire will have higher self-inductance and lower self-capacitance so it will have higher Q and higher feedpoint resistance, which is good in this case because it minimizes the need for a counterpoise (see below).

## Ground, Counterpoise, or No?

All currents flowing into and out of the tuner must sum to zero. The currents in the center conductor and shield of the feedline, due to the applied power, are equal and opposite, so they sum zero. So what about the current flowing into the antenna wire? Since the feedpoint resistance is very high,

allowed to flow on the outside of the feedline.

If the antenna wire is not exactly 1/2-wave long, or detuned from resonance by the proximity of nearby objects, its impedance will be lower, the feedpoint current will be higher, and the counterpoise current and voltage will be higher. Under these conditions, you will find that the SWR will vary significantly when you touch the rig. This can be addressed by adjusting the length of the antenna, adding a counterpoise at the tuner, and/or adding a choke balun in the feedline at the transmitter. Two passes of the RG174 feedline through five or six FB-73-2401 ferrite beads works well for the balun. Alternatively, you can wind five or six turns of the feedline into a 2-1/2 to 3 inch diameter coil.

## Tuner

A variable capacitor is connected across the toroidal inductor forming a tank circuit. The antenna constitutes a load that is in parallel with the inductor and capaci-

## SWR Bridge

tor. When the double-pole double-throw switch is set to the "Tune" position, RF power from the transmitter is applied to a bridge circuit comprised of the three 51-ohm resistors and the input to the tuner. If the tuner input impedance is exactly 51 ohms resistive, the currents in both legs of the bridge are equal and there is no voltage across capacitor, LED, and diode. If the antenna is something other than 51 ohms resistive, there will be a RF voltage across the bridge, which will light the LED.

Because the LED is powered by the RF applied to the circuit, its sensitivity to SWR is higher at higher drive level. The capacitor and diode in the bridge form a voltage doubler that helps overcome the forward voltage drop of the LED, making the SWR indicator more sensitive. The LED will extinguish below an SWR of about 1.2:1 with a drive level of only two watts.

If you are going to use the SWR indicator with more than a few watts of drive, it would be advisable to put a current limiting resistor in series with the LED to prevent burning out the LED. Because of the bridge circuit, the highest SWR than the transmitter will see, irrespective of the tun-





This installment of the DQH column is very exciting in that we come one step closer to having a useful and fully functional piece of test gear. We present a couple of simple hardware modules for the Digital Breadboard project which, when added to the HC908 Daughtercard and LCD already presented in prior issues, combine to form an incredibly useful piece of test equipment in the shack and in the field—an antenna analyzer. The core of the frequency scanning and SWR computation engine is described in these pages and on our companion website, allowing everyone to evolve their Digital Breadboard project to the next functional level. We heavily leverage the techniques and technology devised by Joe Everhart, N2CX in his TTAM column elsewhere in these pages, thus achieving a synergy, synchronously and syntonically from which everyone benefits. (See Joe's column for definition of these Three Syn's.)

Our "Spotlight" section in this installment introduces a special project being done by a very talented QRPer—Dave Ek, NKØE. Dave has a unique blend of interests that will result in a PIC-controlled APRS weather station that will be of great interest to homebrewers, QRPers out in the field, and many other hams at their home stations. He has graciously agreed to let me play along with him on this adventure in PIC design, and we're starting off with some basics of getting started in PIC programming with the ubiquitous PIC16F84 chip. Many readers have asked us to describe the basics of getting set up to use this specific microcontroller, and I could think of no better way than by sharing several issues of this column with Dave as he describes his cookbook approach. In the end, you'll end up with a very cool project that can be used as an automated and Internet-connected, APRS-capable personal weather station for the radio shack.

## Spotlight on...The PIC-based APRS Weather Station Project—Part 1

I'm Dave Ek, NKØE, and George has graciously granted me some of his regular Digital QRP Homebrewing column space so I can share my latest project with you as it develops. I've been a ham now for about

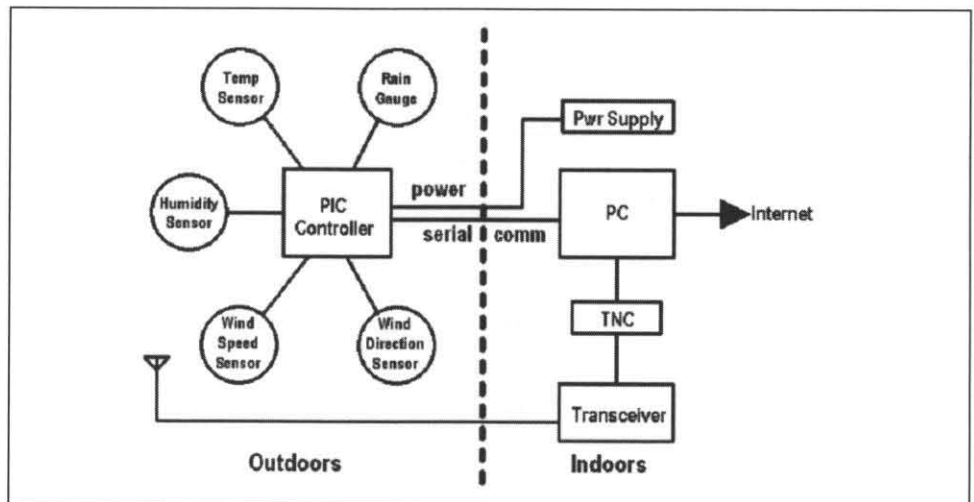

Figure 1—Block diagram of the PIC-based weather station, with APRS interface.

six years, and I've been playing with the PIC16F84 microcontroller for three of those years. My first design was a system of digital setting circles for an astronomical telescope using rotary encoders and a serial link to a PC (see <http://home.earthlink.net/~digicircles>). More recently, I designed the Serial CW Sender, a circuit that allows you to key your CW rig via contesting software running on your Palm PDA. The Serial CW Sender was featured in the July, 2001, issue of *QRP Quarterly*, and you can read more about it and the accompanying software at <http://home.earthlink.net/~golog/>.

Lately I've been experimenting with packet radio and APRS (Automatic Position Reporting System). APRS is quite different from your typical packet BBS. Instead of connecting to a single BBS system, you use APRS software (like WinAPRS or UIView) to periodically beacon your station position on the standard APRS frequency (144.39 MHz), and to plot on a map the positions of other APRS stations heard. Some APRS stations act as digipeaters so that your beacon (and others) is heard over much wider areas. It's typical for my APRS software to show locations of stations all over the state and also in neighboring states. In addition, some stations act as Internet gates, rebroadcasting position beacons onto the Internet where they're heard and displayed at <http://www.findu.com/>. It's pretty neat

to see my station beacon, sent from my station as RF, show up seconds later on the Internet!

"So what?" you say? Good question. It turns out that APRS packets aren't limited to position information. I can send messages, send short emails (I can do this through satellites or even the International Space Station), and even broadcast weather conditions using APRS. Weather, of course, is especially near and dear to the hearts of many hams, since many of us are active as weather spotters during storm season. It occurred to me that being able to automatically beacon weather conditions at my QTH would be especially cool. But alas, I had no weather station, and I couldn't see myself spending several hundred bucks to buy one.

But hey, I could design and build a weather station, again using a PIC microcontroller as its brains. This is the kind of project that I live for. I know that I can make it work, but I'm not exactly sure what it's going to look like when it's done. You know what I mean—it's full of opportunities to learn. After all, it's the journey, not the destination, right?

So, over the next few issues, N2APB has invited me to use his column to share my progress as I tread this path. I'll do my best to include enough information so you can follow along if you also want to end up with a cool homebrew weather station. You'll see that there are many QRP appli-

cations both for PICs and also for the circuitry we'll be using to interface our weather sensors. You can even tag along when I venture down those blind alleys and dead ends—after all, we learn as much from our mistakes as our successes. And rest assured that, as I write this, I really don't know how this project is going to look at the end. I only know that it'll provide some great entertainment over the next several months.

So, let's get started!

## Requirements

It's generally good to know what you want your end product to do when you start a project like this. Quite simply, I want to be able to measure the weather conditions at my QTH, record them on my PC, and then broadcast them periodically using my APRS software and station. In particular, I want to be able to measure temperature, relative humidity, barometric pressure, wind speed and direction, and rainfall. I also want to be able to easily control the time interval between measurements and allow different intervals to be used for different quantities (say temperature every minute and relative humidity every 10 minutes). I don't want to require that all sensors be present, because I'll probably implement them one at a time. I also want to be able to use my PC to do any calibration and conversion so that the weather station itself only has to return raw data (this allows me to fine-tune my sensor calibrations without having to modify the weather station firmware). This will require me to write some PC software, but that's not a problem for me.

I've already decided to use the PIC16F84 microcontroller for this project. I'm using it because it's cheap, easy to program, and I know that it'll do everything I need to do. The PIC will have the job of gathering sensor data and transmitting it to the PC whenever the PC asks for it. The PIC and the PC will communicate via a serial port on the PC. Some of you smart guys know that the PIC16F84 doesn't have serial communications capabilities built in, but I have an answer for that. I'll tell you about it next time.

Figure 1 is a block diagram of how I envision the design of the PIC Weather Station. Obviously, the sensors need to be located outside. I anticipate locating the controller board with the PIC near the sen-

sors outside. I need three lines—two for data and one for ground—for communications between the controller and the PC. If I use 4-conductor phone cable, I can use the spare conductor to provide power to the controller board from inside the house. The PC will be running software that will periodically request sensor data from the controller. When it gets the data, it will process it to turn the raw measurements like voltages into the desired values and then pass the data to the APRS software, which will periodically broadcast it using the TNC and transceiver. Those of you with broadband Internet connections might choose to relay the weather data over the web, too.

I really don't know what this thing will look like when it's finished, but I do know that some of the sensors will need to be "enclosed" to ensure that they give accurate consistent readings. For example, the temperature sensor needs to be shielded from direct sunlight. I'll think more about this as we go on.

## Getting Started

In order to use PICs in electronics projects, you need to be able to do three things:

1. Write the program for the PIC
2. Compile the program
3. Put the program into the PIC

The first two are handled by software you run on your PC. I use a program called MPLab from Microchip, the maker of the PIC chips. MPLab is free, and you can download it from Microchip's web site at [www.microchip.com](http://www.microchip.com). It includes a source code editor and a compiler and can be used to write code for any of Microchip's PIC microcontrollers. MPLab can also directly control many of the commercial PIC programmer devices on the market; these are the hardware modules used to transfer the code into the chip itself. If you use MPLab to write your PIC code, you'll be using assembly language. It looks cryptic and daunting, but it's not nearly as hard as many people make it out to be. Nevertheless, if you prefer to program in C or BASIC, you can also buy other development tools. I'll be using the free MPLab tool for this project. Although I'm not going to try to teach you everything you need to know about writing code in assem-

bly, I'll try to point out the highlights and make sure my code is commented well so you can figure it out. If you're interested in learning how to program PICs in assembly language, get a book by David Benson (not K1SWL) titled *Easy PIC'n*. It's a good introduction. Also read the article by John Hansen W2FS in the October 1998 *QST* Magazine titled "Using PIC Microcontrollers in Amateur Radio Projects." That article got me started with PICs.

Besides being able to write and compile the code for the PIC, you also need to be able to load the code into an actual PIC chip. That's where the PIC programmer comes in. This is a hardware device, usually controlled by software running on your PC, that transfers the compiled PIC code into the chip's ROM memory where it will stay forever, or until you overwrite it with another program. If you'd rather go with a commercial PIC programmer, one economical choice is the EPIC Plus programmer made by Micro Engineering Labs. The EPIC Plus can be purchased from a variety of sources. Jameco (<http://www.jameco.com/>) sells it for about sixty bucks. If you're cheap like me, and I'll bet you are, you'd rather build one for a few bucks that works just as well. The *QST* article by W2FS describes a programmer called the Ludipipo (or JDM) that can be built easily. In fact, you can even get a PC board from FAR Circuits. Another popular homebrew programmer is the No-Parts PIC Programmer by Michael Covington. I use software called IC-Prog to control my Ludipipo. It's free, and can be downloaded from <http://www.ic-prog.net/>. IC-Prog works with quite a few different programmers and shows schematic diagrams of several of them on the web page.

A great thing about this PIC chip is that it can be easily reprogrammed without any lengthy erasure process. With some types of EPROMs, it is necessary to expose the chip to UV light for a lengthy time to erase it prior to reprogramming. The PIC16F84 is an EEPROM (electrically-erasable programmable read-only memory) and can be reprogrammed simply by running it through the programming process again.

I should stress that there are many web pages devoted to various designs for homebrew PIC programmers, and there are quite a few programs that can be used to control them. I suggest the Ludipipo and IC-Prog simply because I'm familiar with

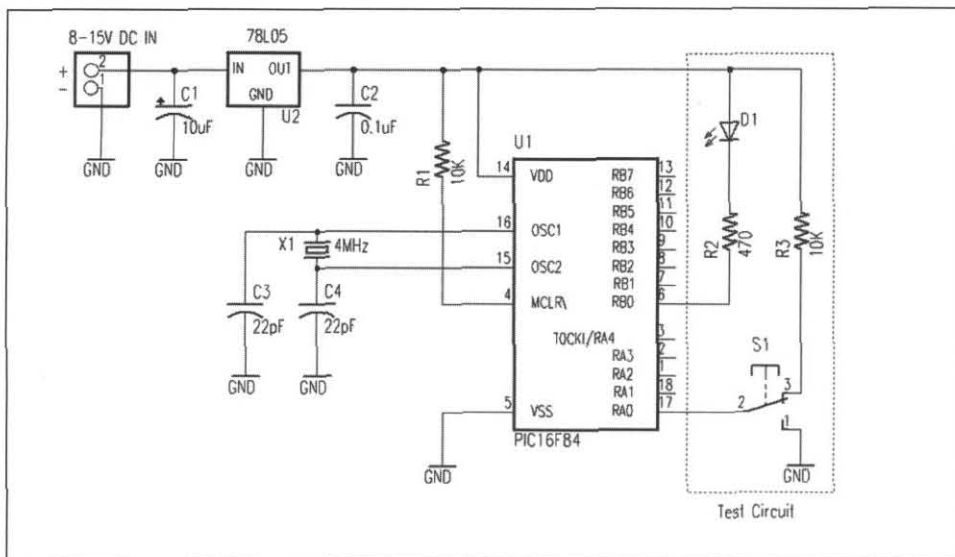

Figure 2—Diagram of the PIC demonstration circuit.

them and I know that they work. If you're brand new to PICs, using these should help to guarantee success. If you're adventurous or experienced, use whatever tickles your fancy.

### What PICs Do

Before we get too far down the road with programming PICs, we should probably discuss what they are and how they work. A PIC microcontroller is a single-chip package that combines a microprocessor, ROM program memory, and RAM variable memory, along with several input and output logic gates. This makes them a one-chip computer, with an operating system supplied by you, the programmer. The PIC16F84 has 13 digital input/output lines. As inputs, they can either be high (+5V) or low (ground). As outputs, they can either be driven high or low. You can decide which lines are inputs and outputs, and can even switch a line from being an input to being an output during program execution.

The PIC16F84 requires a few external components in order to operate. A simple circuit for a PIC is shown in Figure 2. First, a regulated voltage supply is needed. The PIC16F84 can use a supply voltage from 3 to 6V DC. I usually use a 78L05 voltage regulator to provide +5V DC to the chip. A clock signal is also needed. There are a few different ways to do this, but I'm using a 4 MHz crystal for high speed and precise timing. We'll need both later for this project. A 4 MHz crystal, along with two 22 pF capacitors running from either lead to ground, will yield an ultimate

instruction speed of one million instructions per second in the PIC. The only other component needed is a 10k resistor to hold the reset line high. Taking this line low will cause the PIC to reset, which will start execution of its program from the beginning, like it would when first powered up.

The circuit includes a few extra components so that we can demonstrate that the PIC actually does something after we program it and stick it in the circuit. D1 is an LED that can be turned on and off using pin 6 of the PIC. R2 limits the current flowing through the LED. Pin 6 needs to be defined as an output in this case, and you should be able to see that when pin 6 is high (+5V), no current will flow through D1. When we take pin 6 low (to ground), current flows through the LED and it lights. S1 is a switch we can use for input, connected to pin 17, which must be defined as an input. Pin 17 is normally held high, but goes low when S1 is pressed. We can make the LED light when S1 is pressed, or we can make it go out-whichever we prefer. A sample PIC program on the Digital QRP Homebrewing web page uses S1 in this manner to control the lighting of D1.

That's going to wrap up this first installment of the PIC Weather Station project. Your homework assignment is to build a programmer for the PIC16F84 (like the Ludipipo), and then download some programming software (like IC-Prog) and the MPLab software from Microchip. After that, lay out the circuit shown above (use a solderless breadboard-it works great

for PIC circuits) and then cruise over to the Digital QRP Homebrewing web site (<http://www.njqrp.org/digitalhomebrewing/>) and grab the sample PIC program to try out. Next time, we'll cover adding serial communications capabilities to the circuit so it can easily communicate with a PC. After that, we'll be ready to start adding sensors to our weather station.

—73, Dave NKØE  
email: [ekdave@earthlink.net](mailto:ekdave@earthlink.net)

### The Digital QRP Breadboard...First Application: SWR Measurement

This is the fourth installment of our evolving Digital QRP Breadboard project and we're ready for the first real application. Last time, I mentioned an exciting milestone looming ahead for this project...and we're now prepared to state that milestone is an antenna analyzer. This issue's column will establish the algorithmic and computational foundation necessary for us to get there.

As a short recap, and as chronicled in detail on this column's companion website ([www.njqrp.org/digitalqrp](http://www.njqrp.org/digitalqrp)), let's first overview where the project currently stands.

### Review of Current Status

So far we've developed a small computing module called the HC908 Daughtercard that is the brains of the project. It holds the Motorola 68HC908AB32 microcontroller unit (MCU). This self-contained 8-bit microcontroller runs at 8 MHz and has a memory complement of 32 KB of programmable FLASH for program storage, 1k of non-volatile EEPROM for calibration and data constants, and 1KB of volatile RAM for variable and temporal data storage. The 'HC908 has 51 programmable I/O bits, with some dedicated and built-in higher level blocks for A/D conversion, timing and serial port registers. The microcontroller is mounted on a 2" square pc board that plugs into the main board of the Digital Breadboard, or into any other project you might have on your workbench. (You can see an example of how this HC908 Daughtercard is being used as an intelligent controller in the Idea Exchange column elsewhere in this issue).

Other components on the Digital Breadboard include a 4 line x 20 character LCD, an input port for a common IBM PC

compatible keyboard, and a Direct Digital Synthesis frequency source.

Of course, there is software “glue” that holds all these components together, enabling it to actually do something for us. Thus far, we’ve developed simple programs to input characters and voltages that get displayed. We can also generate any given frequency from the sub-hertz region up to 20 MHz. These are useful building blocks or routine libraries, but as yet they perform no synergistic purpose.

This condition will change with the project updates this time.

### This issue’s project:

#### Antenna Analyzer Building Blocks

Now that we have some project basics in place—computing module, I/O devices and a user interface—we’ll start developing some “functional building blocks” that we later use to make a full piece of test gear for the bench. We’re going to start by building a basic absorptive SWR bridge that will be driven by our computer-controlled frequency source (i.e., the DDS) and whose output will in turn drive your antenna system. The analog “results” of the SWR bridge will be read by the built-in A/D converter on the HC908 microcontroller. By sweeping the DDS frequency across a given ham band, and computing the SWR of the antenna system at various points along the way, we’ll have ourselves a rudimentary antenna analyzer. Refer to the block diagram in Figure 3 that illustrates this system.

#### SWR Bridge and Diode Detectors

Referring to Figure 4, a Wheatstone bridge is composed of 50 ohm resistors with the antenna as the “unknown” leg of

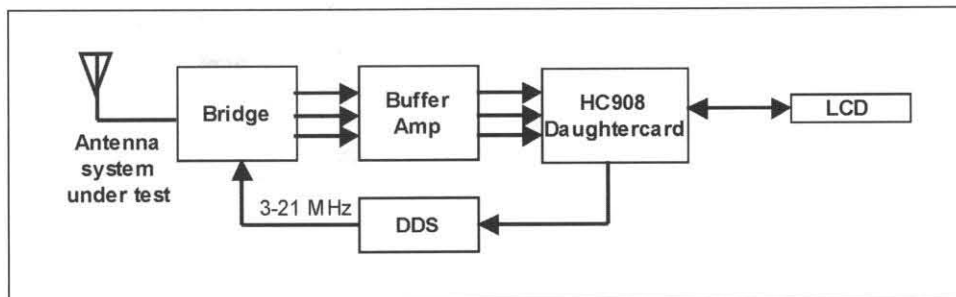

Figure 3—Block diagram of the SWR measurement system.

bridge. When the antenna is at resonance, presenting a minimum impedance with a pure 50-ohm resistive “real” component, the bridge is balanced, and the AC voltages on each side of the bridge are identical. No AC current flows between the legs.

However when the antenna system is not resonant, the complex impedance of the antenna is not 50-ohms but something greater, which creates a bridge imbalance. The 1N34 diode samples that AC signal imbalance, rectifies it, and after filtering, the DC signal is directly analogous to “reflected” sample of more familiar SWR bridges

We sample the “forward” power using another diode detector on the original incoming signal. These forward and reflected DC signals are presented to the next stage for compensation, buffering and amplification.

#### Buffer Amp

There are two reasons for employing the op amp circuits in Figure 5. The first amplifier in each path (FWD and REV) compensates for the nonlinearities in the diode detectors when the bridge is operated at very low power levels. These first stage op amps employ 1N34 diodes in their feedback paths to counteract this problem

with the bridge diodes. This action essentially moves the natural knee of the curves closer to zero, thus improving the accuracy of the readings FWD and REF readings ultimately presented to the A/D input on the microcontroller.

The second purpose for the op amps is to amplify. The DC signal levels coming from the bridge, and through the unity gain of the first compensation stage, are fairly low. In order to make the most use of the 8-bit A/D, we need to amplify the detector voltage up to the 5V range of the A/D. Further, the output of the op amp circuits is quite low which provides a better condition when presenting signals to the 10k input impedance of the A/D. (The output impedance of the diode detectors themselves is approximately 100k ohm. If those signals were directly input to the A/D, they would be greatly affected by the lower impedance of the A/D.)

#### Building the Bridge and Amp

Recalling that we’ve already constructed the other major system components in previous issues—the HC908 Daughtercard microcontroller, LCD, and DDS—all we need to do is build up the breadboard/prototype SWR bridge and compensation amplifier. Of course, later downstream

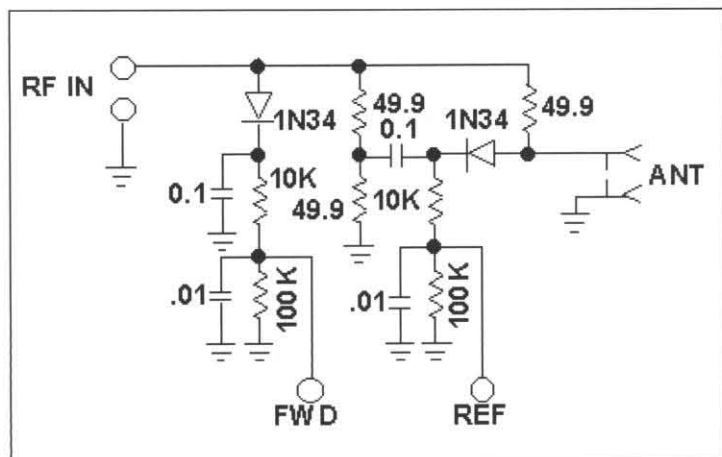

Figure 4—Schematic of the SWR bridge and diode detectors.

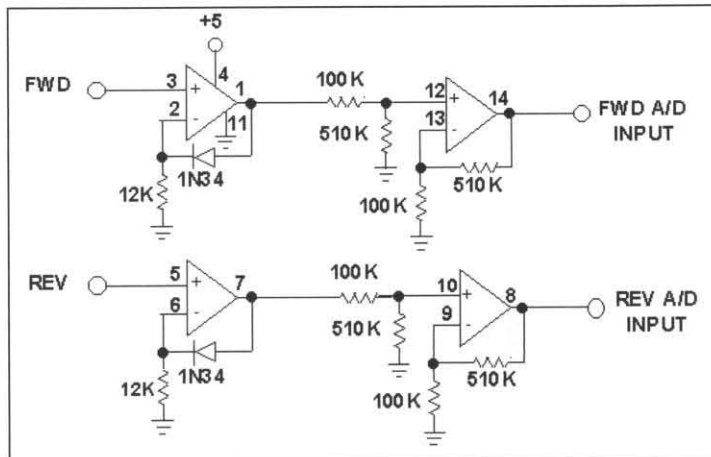

Figure 5—Schematic of the LMC6485 buffer amp.

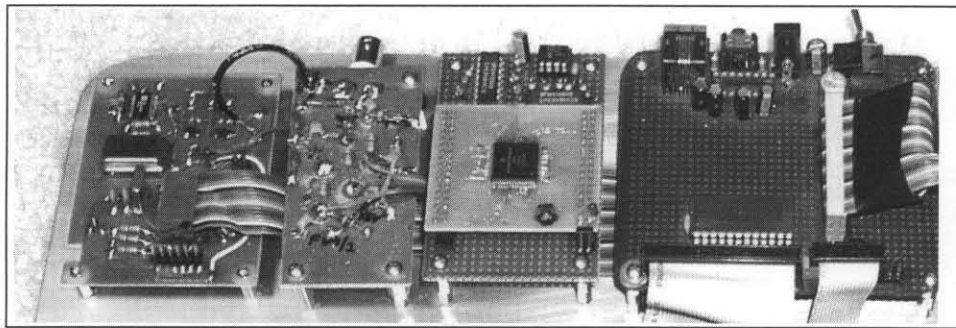

Figure 6—Photo showing layout of the project during heavy-duty debug.

we'll have a pc board developed for all of this, but for now you'll be able to participate in the evolution of the project by homebrewing the project along with us.

No special cautions are necessary concerning the construction of either board. In the examples shown in Figure 6, Manhattan style construction was used to make the bridge board, and perf board construction was used to create the amplifier board.

Shown L-R are the DDS board, the SWR Bridge, the Buffer Amp with the HC908 Daughtercard plug-mounted above it, and the interconnect test base board which supplies the power, attaches the LCD and the In-Circuit Emulator (not

shown but off the photo to the right.)

### Connecting the Modules

Referring to Figure 7, you'll see the schematic of the whole system as it is connected together. I think you'll agree that this shows just how simple and straightforward the hardware design can be for an antenna analyzer. The HC908 Daughtercard is at the center of the project—physically in the schematic, and literally in concept. The functionality packed into that 2" square board allows us to design a significantly capable instrument by only adding a few other components.

### Software Makes it all work!

As usual, the software program we're

describing here, and its corresponding library of routines, are located on the Digital QRP website.

After power is applied and the initialization of I/O devices and variables is done, the mainline of the program is executed. The mainline is a simple loop that performs the following actions over a pre-determined range of frequencies:

- Set DDS frequency
- Display frequency on LCD
- Read analog signals from bridge/amp
- Compute SWR
- Store SWR in list for post-processing

When the scan is complete, the program analyzes the list of scan data to determine antenna resonance (the frequency of the minimum data point) and the Q of the antenna system (how sharp the dip is).

### Setting the DDS Frequency

The DDS frequency, phase and control bits are serially delivered to the device via three I/O lines coming from the HC908 Daughtercard: data, clock and load. Per the details provided in the AD9850 data sheet, the HC908 delivers these 40 bits of programming information by repeatedly setting the data line to the desired value, and toggling the clock line in order to move the data bit into the DDS chip. After 40 such bit clocks, the load line is toggled which instructs the DDS chip to put that 40-bit programming word into effect. At that point, the output of the DDS changes and the new frequency is present on its output.

### Display Frequency on LCD

The frequency is displayed to the LCD by placing the binary coded decimal (BCD) value of each digit into seven sequential locations LCD\_dat+0 through LCD\_dat+6. These digits represent the 10 MHz position through the 10 kHz position in the frequency display. The LCD driver routines take these BCD numbers and display them to specific locations in the LCD memory, thus making them appear on the display itself.

The numbers contained at these locations represent the start of increment/decrement functions (used in scanning), and in subsequent calculation of the DDS programming 40-bit word (used in setting the DDS frequency.)

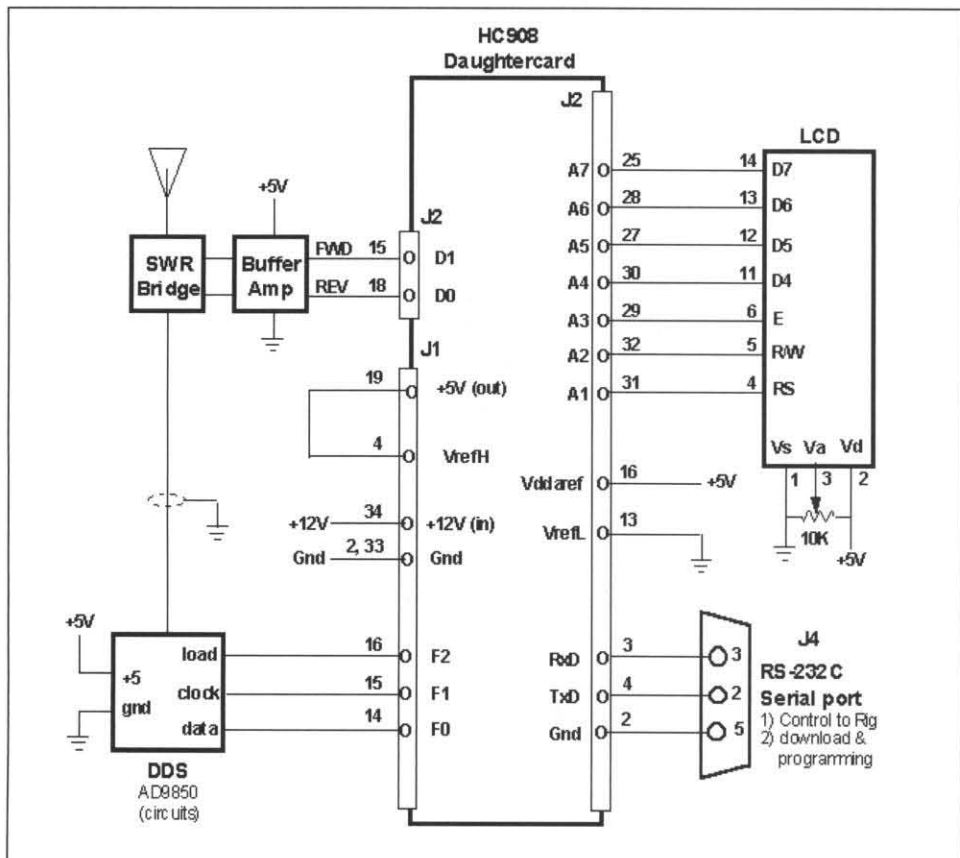

Figure 7—Schematic of the entire Antenna Analyzer system.

## Read Analog Signals

The forward voltage FWD and reverse voltage REV are merely read as 0-5V analog voltages by the A/D converters built into port D of the HC908. These 8-bit converters quantize the analog signal to one of 256 values, based on the analog signal presented on the respective port D input pin. Thus a granularity of 19.531 mV is achieved. This level of precision is entirely adequate for determining even the low-end knee of the diode detectors primarily because of the compensation diode placed in the second op amp circuit for each signal path.

## Compute the SWR

Using measured values to calculate SWR means that instrument is self-calibrating. This is a good thing in test equipment! The following simple equations are coded in the software, using the FWD and REV signals read by the A/D:

$$P = \text{FWD}/\text{REV}$$

$$\text{SWR} = (1+p)/(1-p)$$

## Store the SWR in list

Each frequency sample's computed SWR is stored in a list in RAM memory for processing at the conclusion of the scan.

## Next Time...

That's it for now. Enough information has been presented described here and on our companion web page to allow most homebrewers the opportunity to get a rudimentary frequency scan and SWR analysis loop together for their antenna system at the home QTH. You know where your antenna is resonant—that is, which frequencies it is tuned for—and you can check the operation of your evolving Digital Breadboard against that known condition.

In the next installment (Oct 2002), we'll add a few more human interface components and corresponding software modules to complete the antenna analyzer application of our Digital Breadboard.

This work will result in a real usable piece of test equipment for the shack.

Then in the following issue (Jan 2003), we'll introduce a small DSP plug-in card that will allow us to perform audio modulation and demodulation functions... leading up to a stand alone portable PSK31 station!

Indeed there is much more fun ahead. Please feedback on how you are enjoying the project and what uses you are planning for the Digital Breadboard and the HC908 Daughtercard. Who knows, maybe we can collaborate on a project together and chronicle its development here in these pages!

(NOTE: Be sure to often visit the online version of this column at the companion website: [www.njqr.org/digital-homebrewing](http://www.njqr.org/digital-homebrewing). We regularly place additional project material, color photos, software listings and other project information there for homebrewing readers to use.)

—de George, N2APB

●●

## New Product Announcement: The Elecraft K2/100 100W HF Transceiver Kit

Elecraft's K2 transceiver is now available in a 100-watt model. The K2/100 is based on the K2, with the same features and same world-class receiver performance. It's the only transceiver available that has the portability and efficiency of a QRP transceiver, but—when you need it—packs a 100-watt punch.

Created by Elecraft co-founders Wayne Burdick, N6KR, and Eric Swartz, WA6HHQ, the K2/100 takes HF transceiver kit building to a new level. By using an integral heat sink as its top cover, the K2/100 retains exactly the same form factor as the base K2.

The K2/100 includes a number of features that distinguish it from other 100-watt transceivers:

- Silent, diode-switched transmit/receive (no relays).
- Built-in remote control port with true RS-232 levels.
- Light weight and low receive-mode current drain for enhanced portability—the ideal rig for DXpeditions and field use. (Team Vertical has just completed CQWW CW using three K2/100s as part of their multi-op at 6Y2A.)
- Instant switching between high and low power modes just by

rotating the POWER control. (In low-power mode, the 100-watt stage is bypassed and turned off to minimize current drain.)



- Dual power supply capability, with automatic switching to a low-current backup supply or battery for emergency operation at the 15-watt level.
- All basic K2 features, including dual VFOs, multiple memories, split TX/RX operation, RIT/XIT, full break-in CW, memory keyer, narrow IF crystal filtering, excellent RX dynamic range, and IF-derived AGC.

The K2/100 shares a number of K2 options, including the KSB2 SSB adapter, KNB2 noise blanker, K160RX 160 m adapter with second receive antenna jack, KAF2 audio filter / real-time clock, and MH2 Heil / Elecraft microphone.

The K2 sells for \$589, and the KPA100 100W Integration Kit (internal), which completes the K2 as a K2/100, sells for \$349.

The K2/100 was introduced at the Dayton Hamvention May 17th and is now available from Elecraft.

For more information or to order, visit [www.elecraft.com](http://www.elecraft.com) or contact [sales@elecraft.com](mailto:sales@elecraft.com).

●●

## QRP is! (Confessions of a QRO Op Gone QRP)

Ed Muns—WØYK

Team Vertical

**W**ow...what a blast! Operating QRP from 6Y during the CQWW CW Contest may be the highlight of my 40-year Ham experience so far. Imagine breaking 10 records on a weekend where the A-index was 95 and the K was 7! K2KW, N6BT, N6XG, KE7X and WØYK operated 6 single-op QRP entries (K2KW did two!) to surpass all 6 North American QRP SO single-band records as well as 4 of the 6 world records.

One month earlier, I'd never operated QRP and had no desire to torture myself in that manner. Then, a few weeks before CQWW CW, I was on the phone with Tom, N6BT, about some Force 12 antennas he was designing for my rather windy ridge top location in the Santa Cruz Mountains. He asked if I would like to join "Team Vertical" for the upcoming CQWW with their QRP caper. The 160 single-op position was open and 80 might open up depending on how Bill's, K6KM, health shaped up in the next few days. Bill had just returned from South America and was fighting something picked up from that trip. I was instantly skeptical about a QRP operation, then quickly became a believer because neither Tom nor team leader K2KW would go to this effort without there being a big opportunity...or, just a heck of a lot of fun. Either way, I knew I'd enjoy myself. Little did I know how much I'd enjoy myself.

My first (dumb) move was to exhibit a bit too much excitement to my partner Mary...and, communicate in a typical male fashion, totally ignoring all my "Mars-Venus" training. It went something like this.

**Ed**—Team Vertical's invited me to Jamaica for CQWW.

**Mary**—Neat. When is it?

**Ed**—The weekend following Thanksgiving. It's really cool—we're going to operate QRP with the big Team Vertical antenna farm. We could break some North American and World records.

**Mary**—Neat. When do you leave?

**Ed**—Huh? Oh, the Monday before Thanksgiving.

**Mary**—The Monday BEFORE Thanksgiving?



Contest DXpedition antennas DO NOT spoil the view of a tropical beach!

**Ed**—Uh...yeah, why?

**Mary**—Well, I guess you won't be spending Thanksgiving with me, and at this late date I'll have little chance to make other plans. How could you do this on Thanksgiving?

**Ed**—That's when CQWW CW is...every year. "Thanksgiving" is just a time marker pegging the annual occurrence of this important event. When I think of CQWW CW, I locate it in time relative to "Thanksgiving," but I don't actually think of the social aspects of "Thanksgiving" itself...turkey, family, etc. I really hadn't thought of that angle until you brought it up just now.

**Mary**—How could you do this?

**Ed**—Do what?

**Mary**—How could you leave me on Thanksgiving and not even discuss it.

**Ed**—We ARE discussing it. You can go if you want. If you don't want me to go, then I'll tell Kenny and Tom that I can't make it.

**Mary**—Of course you're going to go. I want you to go. It's just that its Thanksgiving and I wasn't included in the decision.

**Ed**—Decision? I'm asking you...we're "discussing" it.

**Mary**—Well, it sure doesn't feel like it to me. But, don't misunderstand. I really do want you to go. I'm just hurt that I wasn't more a part of the decision.

**Ed**—[Totally confused] Let me get this again. You're hurt that I'm leaving you

over Thanksgiving. Yet, you want me to go and are fully supportive?

**Mary**—Sure. This isn't about your going or not. It's about how you aren't including me in the decision.

**Ed**—I don't get it, but I really do want to go, and you do seem to be saying that you want me to go but I have a feeling that you're not happy about something. (Etc., etc. for the next 2 weeks.)

Later, down in Jamaica, I'm lamenting to Walt, N6XG, about this pre-flight domestic discussion and he tells me it was a snap for him. How so, I ask. Simple, he says, "I told my wife about the trip, but that since it would be over Thanksgiving, of course I wouldn't be going." She immediately says, "Oh no, you must go. It gives me the opportunity to go out to New York and visit our daughter. What a great coincidence." This sounded somewhat like my spousal conversation except his partner seemed happy. Then it hit me. Mars vs. Venus. We're focused on the facts; they're focused on the interaction. And, Walt, the old pro, deftly remembered his Mars-Venus education.

OK, back to CQWW. I am off to a shaky start, but with only two weeks left, I need to prepare. Plane tickets...no problem Mon...5 minutes on the Internet and I'm all booked. Radio? Ah, I have a TS-50 I took to Damascus for the YKØA operation back in '94 so I proudly announce to Kenny that



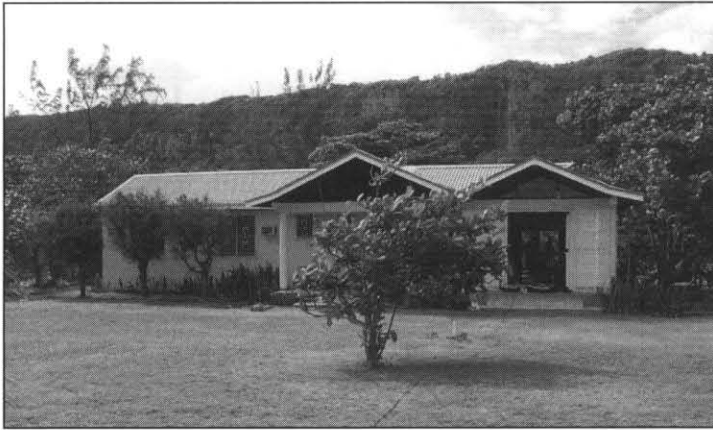

The QTH was comfortable and modern.



Kenny, K2KW, shows off the "Team Vertical" antenna farm.

I'm all set in the rig department. "Nope," he says, "not allowed." "What?" I exclaim. "Unacceptable receiver characteristics... won't handle the pileups." "OK, what IS acceptable?" I ask. So, he explains the various radios that are fine, such as one of my TS950s, but the rest of the crew is taking Elecraft K2s. Not ever having experience with a K2, he is taking his JRC, also partly because he wants to work 6 meters. Tom is also taking his TS850... "just in case the K2s don't work out." So far as we know, no K2s have been tested in big multi-station expedition with potentially huge pileups. But, theoretically, the K2 should perform great.

Well, this was music to my ears. I love building stuff and it had been over 30 years since I built my last Heathkit or anything homebrew of any significance. So, this offered a great excuse to build a K2 which I had been coveting ever since Eric, WA6HHQ, of Elecraft had given a presentation at an NCCC meeting last year. At the time, my only concern was... "What in the world would I DO with a QRP rig once I enjoyed the construction phase?" Elecraft is located just down the hill from me in Aptos, so I arranged to pick up my kit, along with all the various accessory kits, the next day.

With everything else going on in my life, including SS participation for the club, I didn't get started on the K2 until a week before departure...not a lot of margin for issues. Well, other than an un-programmed IOC chip (which controls all the relays and other internal K2 devices), the kit went together flawlessly. The basic kit took me 36 hours, and I got the audio filter and computer interface modules completed as well. That was all I really needed. Just

as I had ordered the K2, we had learned that K6KM wouldn't be able to make the trip, so I was moved into the 80-meter position. Thus, I didn't need the 160-meter module and since we weren't operating SSB, I didn't need that one either. However, I just barely finished the rig before leaving and had no opportunity to operate it...not a way to "prepare" for the trip.

I met up with the other 4 guys at LAX where our non-stop Air Jamaica flight originated. While I knew most of the guys, this was the first time I had met Fred, KE7X. Fred is a really cool EE professor at Bozeman University in Montana, and has been going on expeditions with Kenny for 10 years. Our flight was a red-eye arriving at 6:30 a.m. Tuesday morning before the contest. Two drivers filled their cars with our gear and antennas (with barely enough room for ourselves) and we headed for the villa, 35 miles away on the North coast of Jamaica, just West of Discovery Bay. The groundskeeper and 3 household staff greeted us with a pristine tropical abode. Within minutes of arriving, we pushed the furniture out of the way, set up two large operating tables and soon the living room was a nerd's paradise. Power cables were run from the breaker box and duct-taped to the floor. Kenny unpacked his JRC and Acom 1000 Amplifier on 6 meters in 5 minutes! The 2-element Sigma-6 vertical array was erected on the coral with waves lapping at their bases, and then the 150' of LMR-400 I brought down was connected. Kenny had 6 meters on the air roughly 30 minutes after arrival and worked the US and European openings as they appeared the rest of the day, interspersed with serious antenna construction.

Ultimately, we built 23 vertical elements, configured into 4 basic antenna types:

1. SVDA (Switchable Vertical Dipole Array)—full-size center-fed vertical dipoles in a 2-element set of driver and parasitic reflector. The reflector is switchable to a director, but we didn't use that feature. All directivity was northward to our main running directions: Northwest (US) to Northeast (Europe). On 10m and 15m, 2 of these pairs were phased to create a 4-element array on Europe.
2. Sigma Vertical—shortened center-fed vertical dipoles with "T-bar" capacity end-loading. Also, configured in 2-element parasitic driver/reflector pairs for 6 and 40.
3. 1/4-wave vertical-bottom loaded with a coil, two elevated tuned radials.
4. Inverted-L—compliments of a local 50' tree, two elevated tuned radials.

Here's the band-by-band antenna complement:

- 6m:** 2-element Sigma manually "rotated" by moving the reflector to favor US or Europe depending on openings.
- 10m:** 2-element SVDA on US/JA, 4-element on Europe.
- 15m:** same as 10.
- 20m:** 2-element SVDA pointed at 20 degrees.
- 40m:** 2-element Sigma on US and a second array on Europe.
- 80m:** 2-element base-loaded 35' tall vertical array pointed at 20 degrees.
- 160m:** 50' tall wire inverted-L

By Tuesday evening, all elements were constructed and 10/15/20 were operational. Wednesday, the 40s and 80s were

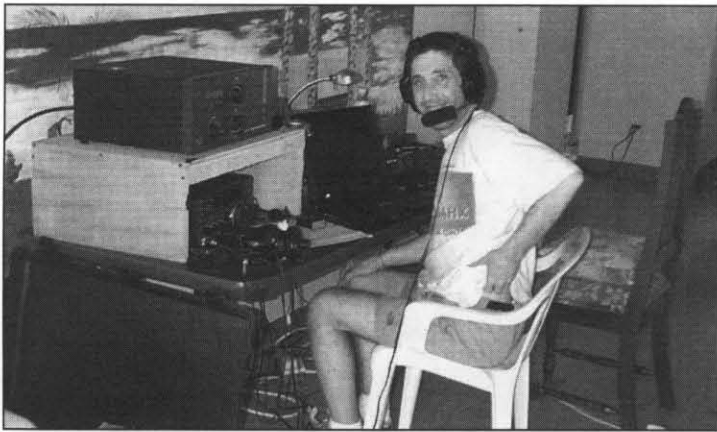

**K2KW with an amp and mic—operating before the contest!**



**That's more like it—the QRP setup with the new K2.**

erected and tuned. Never operating from the Caribbean before, I wanted to get as much airtime as possible on the band before the contest, so I operated 80 through the night Wednesday, from about 5 p.m. until 7 a.m. the next morning. For the first half of Wednesday night, the band sounded like 20 meters—no noise, and lots of loud Europeans. Then, the band noise rose up and stayed that way for the rest of our stay. Kenny and Tom say it's unusual to have such band noise at this location based on previous experience—usually the low bands are as quiet as a mouse. Thursday we constructed the 160-meter inverted-L and it played wonderfully Thursday night. The plan was for me to do both 80 and 160 as single-band efforts...that is, until Tom came down with a severe case of the flu. On Friday, he began to get better close to contest time, but was worried that he wouldn't have the stamina to battle his 40-meter assignment all night. So, we decided that I would do 40, Tom would do 80 as best he could, and Kenny would put in a few hours on 160 after 10 died.

I had to quickly adjust my mind from 80 meters to 40 meters as we reconfigured stations just a few hours before the contest by moving coax lines, coax switches, and building new CT Bin files. On 40 prior to the contest, I could clearly and loudly hear all over Europe, but no one would come back to my calls. I was enlightened that in 6Y, you can hear Europe on 40 and 80 a couple hours before being able to work anything there, even with a kilowatt. Eventually, my QRP signal was heard, and I began running stations. I couldn't believe how well 5 watts was playing. My excitement and anticipation for the contest was quickly squelched when the contest bell went off. I couldn't find a running spot anywhere in the lower 80 kHz of 40 meters! In the first 8 minutes, while everyone else was wildly running, I managed only one W8 in the log. Experimentally, I discovered two things. First, I had to add "CQ" to my CQ message...the 6Y4A call (sans kilowatt) wasn't enough in the initial bedlam. Second, I had to "Search and CQ" because holding a

frequency longer than a few minutes proved futile and pouncing just as much so. While trying to run, I squeezed between two loud stations and was constantly moving my TX VFO 50-100 Hz back and forth to optimize my running frequency. Eventually, the band settled down and I settled into my techniques that began the run. Then, I had the opposite problem...the pileups are HUGE. Kenny and Tom warned me about them, but you have to hear them to believe it. Fortunately, the K2 RX handled them quite well. For those of you who heard Eric's RX presentation at the November meeting, everything he said proved out. The RX really handled the signal overload. My problem then became my own personal ability to pull out the calls from the bedlam. The next 14 hours were incredible. What a high to be running Europe, USA, JA and the Pacific around 1000z. This was what all the preparation was for and I thoroughly enjoyed it.

However, my excitement kept me from sleeping enough during the day, and



**Why are these hams smiling? Because they're having fun at a contest DXpedition, and because QRP is really working well!**



**And now, a message from one of our sponsors—and fellow op, N6BT (right) of Force 12.**

Band	Call Used	Operator	QSOs (duped)	Z	C	ClaimedScore	NA Record	World1 Record	# Of CQs [2]
10	6Y1A	K2KW	2,578	31	99	843,700	242,686	431,060	5,523
15	6Y9A	KE7X	2,166	28	93	637,670	186,102	364,344	4,819
20	6Y2A	N6XG	1,209	23	64	238,728	208,392	230,528	3,706
40	6Y4A	WØYK	1,337	22	72	298,168	90,240	117,262	5,632
80	6Y8A	N6BT	588	14	55	86,763	6,389	105,595	937
160	6YØA	K2KW	162	6	17	7,567	2,232	28,670	198

[1] Note that none of the previous World Records came from NA, so if our claimed scores hold (and are not surpassed), we will have brought 4 World Records to the region.

[2] Does not include multiple CQ's from the CT "Repeat" function, only the initial CQ button push! Looks like WØYK holds the CQ record!

### Final results (claimed) of the 6Y multi-SO operation, listed by band.

Saturday night was a bit more difficult. It was also a series of ups and downs. A JA called in at 0700Z, uncharacteristically early and actually prior to his sunset, so I thought I was in for a very hot band that night. Then, just as quickly, the band died; even the US stations were hard to hear and got watery and fluttery like a polar path during a disturbance. Somewhat later the band peaked again and I started running JAs (along with the US and some Western Europeans). But, suddenly, "poof," no pileup again.

The net result was that my QSO total dropped way below my anticipated rate and overall goal. It was a constant battle to hold a CQ frequency. Right in the middle of my CQ some European and an occasional W would just start CQing on my frequency. I had previously determined that fighting it out was futile, but by now I was feeling more confident, so I pushed back and guess what? I was able to chase stations off my run frequency. Not all the time, but more than I would have thought possible. Then, VQ9X starts CQing beneath my CQs. He obviously couldn't hear me, and I missed a new zone and

country. A 4X called me, but didn't confirm my report, so I had to scratch him from the log. There were many mults like this that slipped through my fingertips. I feel that my mults (22 zones and 72 countries) were lower than they could have been. Looking at other 40 meter results today, convinced me of this. I also felt I could have gotten more out of the pileups, so more practice in that department is planned this coming year. However, 23 hours into the contest (with solar indexes of A=95, and a K=7), I surpassed the 40-meter QRP world record!

All and all, I was learning a whole new kind of operation ...QRP with a typically high antenna gain and a great location for running the USA, EU, and JA. As Kenny explained at the earlier, 5 watts is "only" 4 S-units down from full legal power. And, if your antennas/location are optimized, as ours were, for a S9++ signal advantage over the typical expedition Yagi, then ta daa...it is very much possible to "rock 'n roll" with QRP. This tiny 3-lb K2, that is mostly air inside anyway, was commanding the world. What a thrill indeed.

The net result is that I have a com-

pletely new perspective on "QRP." Transmitter power is just one element of the total system, and not nearly as important as other elements, like location and antennas that are matched for that location. This is not about verticals being better than Yagis. It's about verticals exploiting a salt-water location in a way no Yagis could ever do. Even the 23 vertical elements on our oceanfront didn't look that impressive compared to how they performed. Moreover, the analysis supports the operating experience.

Yes, indeed, "QRP is!"

Thanks again to Force 12 for the loan of the antennas, and to Elecraft for technical support. ●●

*QQ Editor's note: This article was originally published in the Northern California Contest Club December 2001 newsletter, "The Jug," and is re-published here with the express permission of the author, Ed Muns, WØYK, and the assistance of Mary Cherry, NA6E. Our thanks to both Ed and Mary for sharing the story of this DXpedition.*

### ANNOUNCEMENT: GØBPS Elected Vice President of QRP ARCI

The QRP ARCI Board of Directors is pleased to announce that Dick Pascoe is the new Vice President of the club. Dick is well-known to nearly all members as an active QRP operator, G-QRP Club stalwart, and member of the QRP ARCI Board of Directors.

## Designed for Test

Syntonicity, Synchronicity and Synergy are the theme of the "Designed For Test" portion of the column this time around.

Syntonicity these days has an abstruse meaning that deals with the philosophy of learning. However, it used to be used to indicate proper alignment of various tuning components in a radio set to make it operate properly. Synchronicity has to do with activities that operate in time synchronization, and synergy means that the whole is greater than the sum of its parts.

In this context, N2APB and I have begun coordinating our homebrew projects, and the results will appear in future installments of the Digital Homebrewing column by George Heron and Test Topics And More.

By being collaboratively attuned to each others efforts (syntonicity), and meshing them synchronously, the synergy results in projects that benefit from both our best efforts. In short, two heads are better than one! I am a generalist and analog specialist with a smattering of digital and software knowledge, while George is a real software "head" as well as a master of packaging and construction. We complement each other pretty well.

If you are not familiar with Digital QRP Homebrewing because it's "that computer stuff," please take another look. What the column presents is an evolving digital breadboard. It uses a basic processor element based on a microcontroller complete with a simple keyboard and liquid crystal display for operator interaction. This is the brains and the heart of his ongoing project.

So much for the basics, but what else can it do? Well the answer to that is being described in each succeeding installment of the column. The idea is to start simple and to build out from there. George's system is modular and well-adapted to expansion in the form of plug-in circuit cards, and each card will add another function to the Digital Breadboard.

Those other plug-in functional boards are where TTAM comes into the picture. Succeeding TTAM and Digital QRP

Homebrewing columns will present a variety of enhancements, both in the realm of test equipment and other QRP homebrew goodies for the Digital Breadboard.

Modules under consideration include:

- Digital Multimeter module
- Audio generator
- Precision RF voltmeter
- Precision RF wattmeter
- Precision-controlled DC source

While these functions obviously already exist elsewhere, they take on a new dimension when used under computer control. When integrated together to generate and detect signals cooperatively, they can be used for an automated test system capable of precision measurements that would be very difficult or tedious when done manually. And what's more, the Digital Breadboard can feed data to, and be controlled by, a personal computer whose computational horsepower, expanded display capabilities, and large data storage ability offer possibilities for very powerful testing.

The first such module for the Digital Breadboard is a DDS signal generator covering the HF region. In fact, the previous Digital QRP Homebrewing presented this design. Combining a tuning range of the entire HF spectrum, sub-Hertz resolution, and good spurious-free output, it is a handy test instrument for any ham shack.

One of the simplest is to use it in conjunction with an oscilloscope to form a whole new instrument—a rudimentary network analyzer. The analyzer measure peak response frequencies, cutoff frequencies of high-pass, lowpass or bandpass filters, or even amplifiers in your QRP receiver. A stepped voltage output from microcontroller (in sync with the frequency sweep of the DDS) can sweep the scope's x-axis (horizontal) while the scope's y-axis (vertical) axis displays amplitude response of the measured circuit. And several variations on this them make it even more useful:

- Connect low impedance circuit directly to 'scope vertical input
- Use a high-z probe from TTAM #11 across high-impedance circuits

- Use simple diode detector to rectify RF and produce DC output

In addition, a simpler application is to use the built-in frequency sweep capabilities to show the resonance of tuned circuits. Some applications include:

- Series resonant tuned circuits and Q
- Parallel resonant tuned circuits and Q
- Quartz crystal resonant frequencies (as described in Hayward and Demaw crystal filter design articles in *QST* and reproduced in the ARRL publication *QRP Power*).

In fact Digital QRP Homebrewing in this issue of the *QRP Quarterly* describes one way of measuring resonance and Q of parallel tuned circuits.

The Digital Breadboard/DDS combination can also be used in conjunction with a simple resistive bridge for SWR measurements. An earlier instrument of this sort, the Rainbow Analyzer, was described by N2APB and N2CX at FDIM 1998. It used a microprocessor controller to automatically do antenna SWR measurements. However it used a wide-range voltage controlled oscillator as the RF source and suffered some frequency resolution and stability shortcomings.

The DDS overcomes those limitations. It is a wide-range, very stable, and ultimately controllable RF source gives which much better control and precision in measurements. This means that the resulting analyzer has improved performance including LF antenna measurements for non-ham band uses such as the 73, 136 and 160-190 kHz bands. In addition, since it has improved frequency resolution and stability, it is well as suited for adjustment of high-Q antennas such as the so-called magnetic loops. The latter are difficult to measure with more common instruments due to their limited adjustability and stability. This new and improved Antenna Analyzer is the topic of a presentation at FDIM 2002.

In fact this column is somewhat shorter than usual since working on the Analyzer and preparing for FDIM have consumed time normally devoted to TTAM.

## Coming To Terms

A common term used with test equipment is *compensation*. While it has a variety of meanings (depending on the exact context), it generally means using components or circuits to lessen an undesirable characteristic of another component or circuit in order to improve performance.

I like to think of two types of compensation. The first is what I call open-loop compensation, and not surprisingly, the second involves feedback to give closed-loop improvement.

One example of the first kind is the frequency compensation used in oscilloscope probes as described in TTAM 11 last time around. An oscilloscope has a high input impedance shunted by a capacitance. This gives it an inherent low pass response which limits its high frequency response. Increasing input impedance by merely putting a large resistor in series worsens the response. However, shunting the series resistor with a small capacitor adds a high-pass response that can be made to exactly cancel the scopes low pass action. The price paid for thus increasing impedance is that the voltage sensitivity is reduced, but this is often an acceptable compromise.

Integrated circuits use a form of inherent compensation. While resistors, diodes and transistors within ICs have relatively poor tolerance characteristics, since they are fabricated simultaneously on a common piece of semiconductor material, they are closely matched to each other. So IC design takes advantage of the close match by balancing the components against each other so that performance does not rely on their absolute values, but the match between them. And the same effect offers temperature compensation as well since the component variations remain matched with temperature changes. Being on the same substrate, the components remain at basically the same temperature.

Yet another form of open loop compensation is familiar to homebrewers who build their own VFOs. Frequency stability can be achieved by counterbalancing the temperature drift of inductors with suitably chosen compensating capacitors whose temperature coefficient changes their capacitance in exactly the opposite direction.

The final form of open-loop compensation is temperature compensation of crystal

oscillators. Several methods are employed. The oldest and simplest is to house the crystal oscillator in a small temperature controlled oven. Small enough to fit on a pc board, these ovens use temperature sensors and heaters to maintain the oscillator at a constant temperature greater than the highest anticipated ambient value. Thus once they reach their final setting, the oscillators do not drift due to temperature variation of their surroundings.

A more sophisticated crystal oscillator, the Temperature Controlled Xtal Oscillator (or TCXO) uses internal temperature measurement components to sense the ambient temperature and slightly retune the crystal to maintain a relatively constant frequency. This is basically the same idea as using temperature compensating capacitors to stabilize a VFO, though it is somewhat more complicated. While not as stable as ovenized oscillators, TCXOs are much smaller and cheaper, and consume far less power.

A handicap of each of the above open-loop schemes is that they do their compensation based on an estimate of drift made during initial design. If the component values change in unexpected ways there is no way for open-loop compensation to remove those effects.

On the other hand, closed-loop compensation measures the basic parameter of a circuit that is most important and continuously readjusts the correction to correct any drift or variation that happens whether expected or not. Modern high quality electronic equipment makes extensive use of closed loop feedback for compensation.

Receivers have historically used several forms of feedback compensation. Before the advent of Phase Locked Loop (PLL) tuning, most FM receivers used Automatic Frequency Control (AFC). AFC keeps a receiver tuned to its input signal by detecting any drift in tuning and readjusting the receiver's local oscillator to counteract the drift.

AM or SSB transmitters maintain their linearity and constant output power using Automatic Level control (ALC). ALC works by monitoring a transmitter's output power and adjusting amplifier stage gain to eliminate any power variation.

High-priced test equipment does auto-calibration by periodically performing internal performance testing and automatically readjusting itself to compensate for

any performance changes detected.

In a sense, the NJQRP Antenna Analyzer described at FDIM 2002 does this by design. In measuring SWR and impedance, a microcontroller monitors the drive level of an internal signal generator and performs its measurement calculations based on the drive level. Most simple ham-quality test equipment calibrates its drive level in the factory and relies on simple feedback to attempt to maintain constant levels. By not constantly measuring drive levels, they do not compensate for long term drift that inevitably takes place. As the saying goes—*drift happens...*

The final form of closed loop compensation is the familiar Phase-Locked Loop. The PLL uses a feedback loop to compare the phase of a sample of an oscillator's output signal to the phase of a stable reference oscillator. Any drift in output phase (and phase change with time is frequency) is automatically removed by retuning the oscillator.

## Stimulus and Response

An attendee from the recent NJQRP Atlanticon queried me about a project that Jim Kortge, K8IQY, discussed during the presentation. Jim's project is a Precision Variable Crystal Oscillator or PVXO. The question was, just what would I use it for?

The simple answer is that the PVXO is intended for use in measuring quartz crystal characteristics. And why measure quartz crystals? Well that has a very good answer. Wes Hayward, W7ZOI, has written several excellent articles on homebrew quartz crystal filters that describe these measurements (see References at the end of the column.) One of the necessary items needed to run the needed tests is a very stable signal generator that can be tuned accurately down to one Hertz or less.

This can be done with an ordinary signal generator or VFO, but getting that kind of resolution and stability is lots of work. Jim reasoned that since crystals are inherently stable, and since you need a bunch of them to match for filters anyway, you might as use one of them in a test oscillator. And, in his usual very painstaking manner, Jim designed a superb piece of test gear well suited to the task. Jim's prototype unit has been put to good use in matching crystals for filters in his very popular 2N2-40 rig. While no kit is currently sold for the 2N2-40, there has been

lots of demand from homebrewers for filters, so Jim matched up a bunch and made them available as an aid to those rolling their own rig.

Now I have other uses for this device as well. One of my on-going homebrewing projects is a never-ending series of variable crystal oscillators (VXOs), and guess what—you need to do the same sort of measurements for them as you do for filters! So when I saw the PVXO I just had to have one.

That's just a teaser. Future TTAM columns and articles in the QRP Homebrewer will present lots of material on how to use this new piece of test gear. Meanwhile, you can read more about it in the 2002 Atlanticon Proceedings. See <http://www.njqrp.org/atlanticon/proceedings.html> to order one, or you can purchase a PVXO kit from NJQRP. (<http://www.njqrp.org/pvxo/index.html>)

That's about it for now. Please be sure to send in questions on test issues, test

equipment, or circuits. You can send them to me by snail mail or e-mail, or look me up at one of the NJQRP meetings or one of the QRP symposia.

**Ref 1**—Wes Hayward, W7ZOI, "A Unified Approach To The Design Of Crystal Ladder Filters," *QST*, May 1982.

**Ref 2**—Wes Hayward, W7ZOI, "Designing and Building Simple Crystal Filters," *QST*, Jul 1987.

••

## QRP Clubhouse

Mike Fletcher—KL7IXI/7

kl7ixi@attbi.com

### Summer at last!

Even here in the Pacific North "wet" the sun's rays are peeking through the clouds. Field Day is just a few weeks away and rigs built over the winter have yet to go to the field.

Speaking of the field, what better opportunity to expose some QRO Ops to the fun of QRP than inviting them to join a QRP Field Day and see for themselves? And don't forget spouses, especially on a SSB station. Something about YLs on a radio always equals increased contacts.

Boy Scouts still have radio, electronics, and Morse code merit badges. Another source for new blood in a club, and the Scouts do know how to camp.

### Clubs

- The North Georgia QRP Club and Flying Pigs QRP International sponsored the "buildathon" at this year's Dayton Four Days In May (FDIM) QRP Seminar. Thirty-eight hams built the NoGaQRP Club version of a Stockton meter, designed to fit into an Altoid tin. If you haven't built one of these little kits they are the perfect accessory for a ZM-2 tuner if you prefer to see waving meter needles instead of a LED. (FDIM is covered in more detail in other pages of this issue.)

- The Long Island QRP Club participated in the Ham Radio University 2002 for Long Island, with a set-up of QRP rigs and portable antennas. Norm Wesler, K2YEW, gave a seminar on Low Power Communications Fun.

- The Colorado QRP Club will be manning two Field Day QRP stations, one urban, another in the Colorado foothills.

CQC's Field Day 2001 score was third overall in the nation.

- The Houston QRP Club presented four QRP seminars during the June Ham-Com in Arlington, Texas and are preparing a Field Day effort.

- Welcome to the Indiana QRP Club who is working on their website. Drop by their Guest Book and sign in: [www.accent-tech.com/qrp/](http://www.accent-tech.com/qrp/).

- A club website I always enjoy visiting is the Australian QRP Club. The club has a Yahoo mailing list and some great information for newcomers to QRP. Their website is: <http://www.alphalink.com.au/~parkerp/qrp.htm>.

- The Little Thunder QRP Club in Thunder Bay, ON now has a club call sign: VE3LTQ.

### Congratulations

And while not a club item, I'd like to offer *QRP Quarterly's* congratulations to the youngest ham to be licensed this winter, six-year-old Jessica Dowding, KD7PIO, of Bountiful, Utah. A great effort for this QRP-sized Technician.

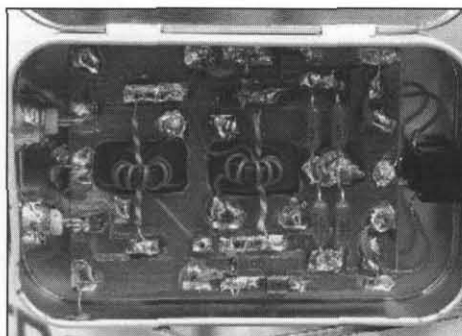

### Mailing Lists

The Internet has become an indispensable source of information, especially for Ham Radio information and archives. Several groups have moved to the Yahoo Groups/Clubs area. One such group of interest is the hfpack, the HF Portable Group with some innovative ideas on backpack and portable setups. I recommend setting your membership profile to "No email." Don't send me email, I'll read the messages at the Web site, as it is an active group and tends to fill up a mailbox.

Another active list is the QRP-Canada Reflector, "the small list with the big heart."

### Get Your Club Noticed

If you would be interested in having your club profiled in this column, drop me a line at [kl7ixi@attbi.com](mailto:kl7ixi@attbi.com), or via snail mail at 2162 NE Kevos Pond Dr., Poulsbo, WA 98370. Send along some pictures or other artifacts of your activities to share with your fellow QRPers.

—de Mike, KL7IXI/7

••

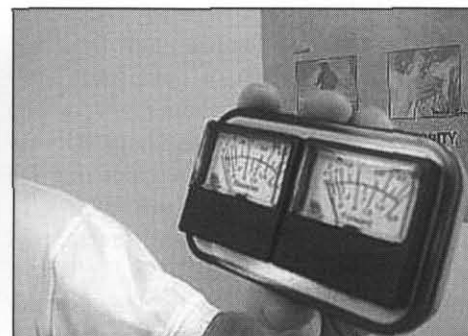

**W3IRZ's original NoGaWatt prototype, inside and outside. Photos courtesy of the North Georgia QRP Club.**

# Convert Your Power Meter to Read CW and PEP

Ian Keyser—G3ROO

ian@g3roo.fsnet.co.uk

The following article was submitted by Ian Keyser, G3ROO, and was originally printed in the G-QRP publication, *Sprat* (issue 110).

Licensed since 1962, Ian is married to Margaret, MØROO, and they have two grown children. In 1979, he founded Kanga Products (then known as Kanga Electronics), and when taken ill in 1984-85, he took on GØBPS as a partner. Up until the early 90s, he wrote extensively for various magazines, including *SWM*, *Rad Comm* and *SPRAT*. In 1992, he sold his interests in Kanga Products so he could spend more time in amateur radio and his second love, gliding.

The article covers the design of a PEP module for upgrading VSWR bridges or power meters, or to be included in a new homebrew meter. The folks in the G-QRP liked it so much they requested he supply it as a kit. It is available directly from Ian, or through Bill Kelsey at Kanga, U.S.A. via their web site at [www.bright.net/~kanga/kanga/](http://www.bright.net/~kanga/kanga/).

## CW-PEP Power Meter Conversion

Those who have email and subscribe to the G-QRP list will know that since *Sprat* 109, there has been some ongoing correspondence regarding PEP and CW power measurements.

While CW power is relatively easy to measure, single sideband (SSB) has a 'mean' output power of between 10 and 20 percent of the peak output (providing the amplifiers are not being overdriven), and it is a little more difficult to measure accurately. Our output powers for various modes, as far as our license is concerned, was calculated for SSB as being the same total output power of a fully modulated 150 watt AM transmitter.

Back in the 70s when QRP SSB was rare in the G-QRP club and I was SSB manager, long frank discussions were held on this subject and finally the levels were set at 10 watts PEP and 5 watts CW.

Measurement of your PEP is not difficult and never has been! All we require is our power meter to display the peak voltage from its detector. Of course during SSB measurement the meter does not have time to display this reading and so will indicate a much lower level.

All that is required is a simple 'sample and hold' circuit with a time constant of one second or so enabling the moving coil meter to indicate the reading. The meter, then calibrated under CW conditions, will indicate the peak readings during SSB conditions.

Other requirements for the circuit are that it will have an overall gain of one,

enabling it to be 'retrofitted' to most power meters, and a single supply line. My circuit has been tested with the Stockton power meter and works superbly.

In my station I have a switch on both forward and reverse meters and usually run with the forward power on PEP and reverse on CW. This enables me to read CW output power while sending CW (meter remains reasonably steady) and I am unable to retune the ASMU (Aerial System Matching Unit) without switching back to CW on the reflected power meter. The 'hang' when switched to PEP makes tuning very difficult!

A single LM324 quad op amp is used. Two amps used on the forward PEP meter and the other two spare op-amps in the package are used as drivers in the CW mode. The reason for this is that if we were to use a switch to select PEP from the module, and then CW direct from the detector, a difference in readings will be obtained. This is due to the meter loading the detector in the CW mode as the op-amp input impedance being very high causes negligible loading. This will require the meter to be recalibrated for full scale deflection. This can easily be done using a transmitter with known output.

I have included on the PCB range resistors and presets in series to enable easy calibration. Three ranges have been included as my meter has full scale deflection of 1, 10 and 500W. The value of the resistors and presets will have to be obtained by observation of the component values in the old design. As the value will have to be increased to compensate, I would suggest the same value be included as the fixed resistor and a preset of 25% of that value would be sufficient for adjustment. In my case, the value was less than 10%. Each range resistor is selected by a panel mounted two pole, three way switch, and an additional single pole two way switch is required for PEP or CW selection.

If there is sufficient interest in this design I will have PCB's and kits made up. I can be reached by email at [ian@g3roo.fsnet.co.uk](mailto:ian@g3roo.fsnet.co.uk).

—72/73, Roo

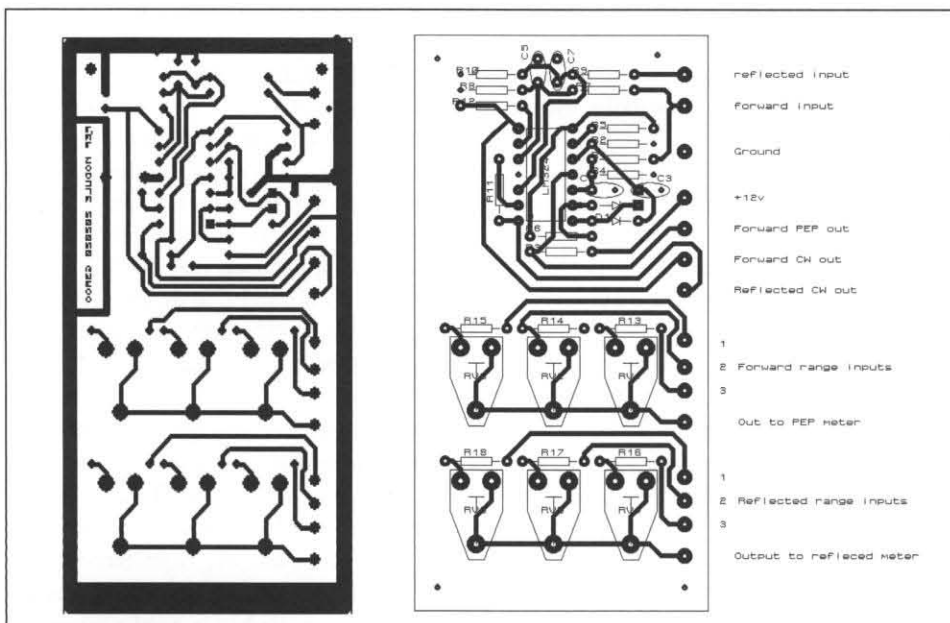

PCB foil pattern (left) and parts layout of the CW/PEP conversion board.

# Variable Power Supply Regulator / Current Limiter

Steve Weber—KD1JV

kd1jv@moose.ncia.net

This regulator board provides a variable 0 to 14 volt output and a 0 to 2 amp current limiting function. Ideally, the regulator should be powered with a raw DC supply of at least 15 volts with a full current rating of 2 amps. However, the regulator can be used to add variable output and current limiting to any fixed output supply, like a 13.8V bench supply or Gel-Cell battery, with some reduction in the maximum output voltage available.

## How It Works

The voltage regulator is comprised of three major active parts: 1) the pass and driver transistor, 2) the error amplifier and 3) a voltage reference. The unregulated raw DC is applied to the emitter of a PNP power transistor, Q1, a MJE2955T. A PNP transistor is used instead of an NPN so that a “low drop out” regulator configuration is achieved. By using a PNP transistor, as little as 0.5 volts may be dropped across the transistor. Had a NPN been used, as much as 2 volts might be lost across the transistor.

The output voltage on the collector of the pass transistor is applied to a voltage divider and then to the negative (–) input of the error amplifier, 1/4 of an LM324 op-amp, U1A. The positive (+) input of the error amplifier is connected to the voltage output control pot, which in turn is connected to the voltage reference, an LM78L05 +5 volt regulator. If the voltage on the (+) input is greater than the voltage on the (–) input, the output of the amplifier goes positive. This applies base current to the driver transistor, Q2, a 2N3904. As Q2 turns on, it pulls Q1’s base current to ground, which causes the voltage on its collector to rise. At the point at which the collector voltage causes the (–) input of the error amp to be equal to the (+) input, the output of the error amp stabilizes. Capacitor C3 keeps the error amp from oscillating around that point.

As larger amounts of current are drawn from the output of the regulator board, larger amounts of current must be drawn through the base of the pass transistor to ground to keep the output voltage constant. An LED diode, D1, in series with the base of the pass transistor, provides a visual indication of the amount of base current

being drawn, and hence a rough indication of the output current.

In order to sense output current, a 0.1-ohm resistor (comprised of five, 0.5-ohm resistors in parallel), R5, is placed in the return path of the output ground to the raw DC supply.

Note: The output “ground” cannot be connected to the input supply “ground;” doing so would short R5 resulting in no current limiting action.

One ampere through R5 will result in a 100 mV drop. This current sense voltage is then amplified by a non-inverting amplifier, U1B, by a factor of 10. This gives us a more reasonable voltage to compare to. This amplified current sense voltage is compared to the current limit set point, determined by the voltage on the wiper of the “I LIMIT” control, V2. Op-amp U1C is used to compare the output current to the set point voltage. When the output current-generated voltage on the (+) input of the comparator exceeds the set point voltage on the (–) input, the output of the comparator goes high. This turns on Q3, which pulls the reference voltage on U1A to ground, which makes the output voltage of the regulator board turn off. R11 isolates the input of the op-amp from the output voltage control pot, V1. Without this resistor, if the wiper were set to the top of the control, Q3 would try to short out the reference voltage regulator.

D2 is connected back to the input of the comparator, through a normally closed switch, so that once triggered, the comparator latches on. Op-amp U1D is used to light an LED for a visual indication that an over-current situation occurred. If the over-current LED comes on, you know you need to find a fault in the circuit you are powering.

A 1N4001 diode is reverse-connected across the pass transistor, Q1. This protects the regulator circuit should the output voltage exceed the input voltage. This might happen if a large capacitance is connected across the output and the input voltage drops faster than the output when the supply is turned off. Or, it might happen if the regulator is being used to charge a Gel-Cell battery and the supply is turned off before the battery is disconnected. There is also a

diode (D4) connected in series with the supply to the op-amp and reference regulator. This prevents damage to these parts if the input voltage polarity is incorrectly connected. There is a risk that C1 might explode if the input voltage is reversed, so this condition is to be avoided! [A 3-amp or larger Shottky diode could be connected between the (+) input power connector and the rest of the circuit for complete reverse-polarity protection; in that case, D4 could be eliminated. — W1HUE]

## Construction

How you build the regulator is not critical; any method of construction is acceptable. Circuit boards for the regulator will be available from FAR Circuits for \$4.50 each plus shipping and handling. Look for the “KD1JV Power Regulator Board” on Fred’s web site, <http://www.farcircuits.net>.

## Power-Up and Test

Before you put power to the regulator board, do a double check of component placement. Make sure you didn’t mistake the 78L05 regulator for one of the transistors. Use your ohmmeter to make sure that neither the input nor output is shorted to ground. Turn both the voltage out and current limit controls fully clockwise. Now apply power (being sure to observe the correct polarity) to the board. Place a voltmeter across the output and see that you can adjust the voltage out, from maximum down to zero (0) volts. The actual maximum output voltage from the regulator board will vary depending on the raw DC voltage used and the exact output voltage of the 78L05 used as the reference voltage. The 78L05 output can vary by  $\pm 250$  mV from unit to unit and due to the influence of the voltage divider network, the actual output voltage can deviate as much as 1 volt from the specified 14 volts maximum.

Turn the output voltage back up, then turn the current limit control all the way down. The over-current LED light should come on. Turn the current limit control back a bit and push the reset button; the LED should go off. If the board passes these tests, it is ready for final packaging and use.

If you have trouble, the most likely



cause is a misplaced part or a bad solder connection. It is also possible that there is an open track on the circuit board. If you can't see anything obvious, use an ohmmeter to check continuity. [If the current limit fails to work, you may have the input and output "grounds" directly connected together thus shorting R5. —WIHUE] Typical voltages are not given on the schematic, as most of them will vary depending on what the output voltage is set to and how much current is being drawn from the regulator.

### Packaging

It's always a good idea to package a power supply in a box, generally a metal one. Five-way binding posts are recommended for the supply output terminals. Note that the output ground of the supply is "floating," as output current must flow through the current sense resistor for the current limiting function to work. Therefore, the output ground of the supply must not be connected to the frame of the box it's enclosed in. In addition, neither should the ground of the raw DC supply feeding the board. The only ground connected to the box should be the green ground wire of the AC cord. If both the AC line ground and the raw DC supply is grounded to the box, it is possible that if the device being supplied by the regulator is also connected to AC ground, say by connecting up an oscilloscope ground to the device, the current limit sense resistor will be by-passed and you will lose the current limit function.

A board-mounted heat sink should be adequate in most situations, but see the next paragraph for when it will not. It will become marginal if near rated current is being drawn at low output voltages for more than a few minutes at a time. Adding a 12-volt cooling fan will help a lot.

### The Raw DC Supply and Ripple

If you plan on making a self-contained AC-line powered bench supply with this regulator board, you will need to add a raw DC supply, consisting of a power transformer, full wave rectifier and filter cap. Since we are using a "low drop out" regulator scheme, a 12.6 volt transformer will provide enough voltage, provided the ripple voltage is kept low. The peak, zero-current DC voltage from a 12.6 volt RMS transformer will be about 15.8 volts. ( $12.6$

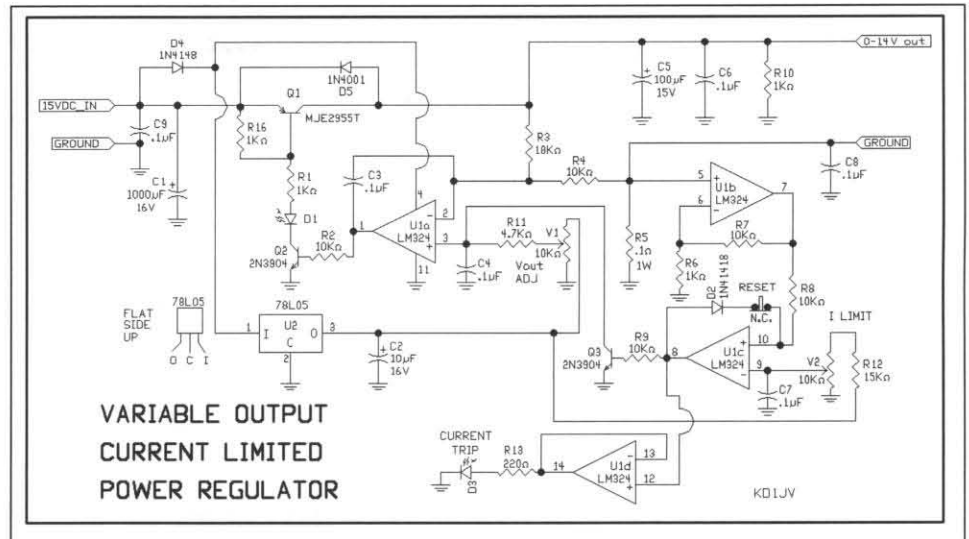

Figure 1. Schematic diagram of the regulated power supply.

$\times 1.414 = 17.8 - 2$  (rectifier drop) = 15.8V) Assuming a 0.8 volt drop across the pass transistor at 2 amps and a maximum output of 13.8 volts, the amount of ripple on the raw DC supply needs to be no more than about 1 volt in order to keep ripple off of the supply output. This means a pretty big filter cap. The exact value can be calculated by the formula:  $C = I \times t / E$ , where C is in mF, I is the current in mA, t is time between half cycles of the rectified wave form in ms (7.5 ms for full-wave 60 cycle) and E is the amount of ripple. So,  $C = 2000 \text{ mA} \times 7.5 \text{ ms} / 1 \text{ V} = 15,000 \text{ mF}$ . Instead of one big 15,000 µF cap, three 4700 µF caps can be used in parallel. Be sure to use rectifier diodes that can deliver a large surge current into the filter caps!

It is common to use an 18 volt RMS transformer to power a 13.8 volt supply. This greatly reduces the size requirements of the filter cap, since we're starting out with about 25 volts. However, this greatly increases the size of the heat sink needed for the pass transistor. Over 20 watts will be dissipated by the pass transistor at 13.8

volts output and full current output of 2 amps. The dissipation will be even higher if the output voltage is set lower than 13.8 volts. A larger heat sink will be required and the voltage rating of C1 must be increased from 16 volts to at least 25 volts.

### Changing the Voltage Output and Current Limiting Control Range

The maximum voltage output can be changed by adjusting the value of R3. The value needed can be calculated by  $(V_{\text{max}} - 5) / 0.5 = \text{kohm}$ . The maximum current limit can be changed by adjusting the value of R12, up to a maximum of 5 amps. One amp at the input to U1c, so set the maximum voltage at the top of the I-Limit control equal to the desired maximum current limit.

### Using the Regulator to Charge a Gel-Cell Battery

Since Gel-Cell batteries like to be charged with a constant voltage and limit-

R1,6,10,16	1k 1/4-watt 5%	D1,3	T1 size Red LED
R2,4,7,8,9	10 k 1/4-watt 5%	D2,5	1N4148
R3	18 k 1/4-watt 5%	D4	1N4001
R5 (a,b,c,d,e)	0.5 ohm 1 watt 5%: (5) 0.5 ohm 1/4-watt in parallel	Q1	MJE2955T
R11	4.7k 1/4-watt 5%	Q2,3	2N3904
R12	15k 1/4-watt 5%	U1	LM324N — do not sub!
R13	220 ohm 1/4-watt 5%	U2	78L05 100 mA, +5V reg.
C1,5	1000 µF, 16V Electrolytic	V1,2	10k linear pots
C2	10 µF, 16V Electrolytic	S1	Normally closed pushbutton switch
C3,4,6,7,8,9	0.1 µF monolithic or disk	Heat sink	Avvid 529802B25

Figure 2. Power supply parts list.

# Ramblings of a Displaced Cajun Lad in Maine

Joel Denison—KE1LA

hamjoel@juno.com

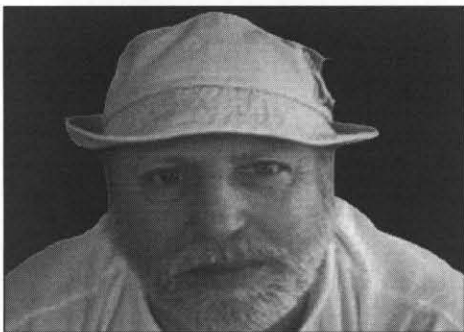

## A phone call to mama...

As u kneaux, my cajun mama lives back in louziana, southwest louziana, cajun country, and avery now and then ah call her on the phone... here bees one of them calls.

"Hello mamma? This is ur son, joel, up heah in maine..."

"What u mean, joel who?"

"Ask daddy, he may remember me..."

"Hey paw, got one on the line named joel and claiming to be one of ours, u remember that one...?"

"Yea maw, he's the one with the qrp infection."

"High son, according to ur daddy this is ur mamma speaking, what can ah do for u...And how's ur qrp infection?"

"It's not an infection, mama, it's a radio thing..."

"Oh good, peaux boy, we thought u was suffering thair..."

"Oh no mama, fact is ah is gotten ready to geaux do fdim with the flying pigs and qrparki..."

"Aw son, u need to leave that urologist alone and got u self a good shrink."

"No maw u don't understand..."

"Listen heah, son, ah ban round long enough to kneaux a problem when ah hears one...and u bees loud and clear..."

"Oh mama, I herd u done won the cajun 22 shootout...is that true?"

"Sure thing, Son... even got a medal for saving old doc leblanc's life..."

"Really, maw, what happened?"

"Seemed he was sittin' with his big old hinnie jutting out when a bumble bee come sat on it...He's allergic to bees u kneaux...Well, ah shot that little critter from 50 yards... clean hit, fact is I ain't nicked old doc much at all...maybe one drop of blood, that's all...Well, after they decided ah wasn't trying to kill the old codger, doc leBlanc said any woman what would look at his hinnie at his age deserved a medal..."

"That's great maw, and did they find the bullet too?"

"Oh yeas, son... u could tell it was the right bullet... The face of that surprised bumble bee was right on the front of the bullet...Did u kneaux alphonse and claudette be 'specting again...?"

"Really maw?"

"Oh yeah, great big to-doo over at thair place...seems alphonse done nailed the back door and windows shut tight...he be an insecure man u kneaux, heck she done said it was his, she got no reason to lie bout that...Son u remember that big old gator, stomper... what live up at the end of the bayou? One of the trappers caught him, but had to turn him loose..."

"Why was that, maw?"

"Well, seems his 22 shell kept bounc-

ing off the critter... and then when he put old stomper in his boat, the dang boat sank... at that point pierre thought it might be best to set stomper free before he got the critter mad.

"All that's good to heah, maw.. Guess things going ok for u and paw..."

"Yeah, son, ah just cooks up some of my good ole cajun kickapoo juice now and then and all paw's miseries just seem to fade by the bayouside...leroy boudreaux done got one of them ham licenses, u kneaux..."

"Really, maw?"

"sheaux nuff, son...fact is, the 'lectric company ban looking for him ovah a month now..."

"What happened maw?"

"Seems he short cirtuited some power lines with an antenna project... heck they lost 'lectricity from new iberia to thibedeaux, louzianna... The last thing folk saw of lero y he was in his pirogue headed cross vermilion bay heading towards the gulf of mexico.... If the fishing is good he won't be back for a month or so..."

"Wow, seems u ban having lots of 'citement thair maw... thanks for all the information and I'll call u later..."

"Ok son, now u take care of that qrp problem u heah?"

"Yes, mama..."

Sometime ah wonder why ah don't call home meaux. Then ah call home and find out...:-)

—de joel in maine

●●

(See Joel's "report" on FDIM on page 44)

## (Variable Power Supply...continued)

ed current, this regulator will do a good job of charging them. You will, however, need to add a toggle switch in series with the current limit reset switch so that the latching function can be turned off. This will cause the regulator to produce current pulses into the battery. By monitoring the brightness of the current indicating LED, you can tell when the battery is charged (when the LED gets dim).

## Adding Metering

You can add markings to your voltage and current limit knobs simply enough, but it would also be nice to have metering. Analog meters are simple enough to add, but can be expensive if bought new and take up a fair amount of front panel space. Relatively inexpensive 3.5 digit digital panel meters are available from several surplus dealers. A 200 mV full scale meter can be placed across the current sense resistors and read the current without the

need for any other scaling, as 100 mV = 1 amp. Be advised, though, that many of these digital panel meters need to have an isolated, floating supply in order to work. Typically, this is a 9-volt battery. If you want the meters to run from AC, you will need to build a supply to run the meters. A small transformer with two 6.3-volt secondary windings would work. Add a rectifier and filter cap to each secondary to power each meter.

— de KD1JV

●●

# QRV? "Seeing" Radio Signals

Mike Boatright—KO4WX

ko4wx@mindspring.com

Last week, a friend of mine told me that he had just bought a new ICOM IC-756PRO. He said that what he liked the most on the rig was the bandscope—that fancy thing that tells you where the guys with the 10 kHz wide signals are.

That got me to thinking—have you ever wondered how one of those things works? It is quite simple, if you think about it. All it really takes is (1) a way to scan the band looking for signal levels, and (2) a way of measuring and plotting signal levels. Measuring signal levels is pretty easy—nearly all commercial rigs, and a lot of kits, have a device that does that. It is called the "S-meter." And most commercial rigs (and nearly all VHF rigs) have a scanning device—usually implemented using a thing called a Voltage Controlled Oscillator or VCO.

## The Voltage Controlled Oscillator

The simplest VCO can be built using a component called a varactor diode. All diodes have an interesting property in that when they are reverse biased, they behave just like a capacitor. As the reverse bias voltage is increased, the capacitance is reduced. Most diodes can be used as varactor diodes (for example, the 1N4001—the cockroach of rectifier diodes, available at any Radio Shack store—is often used in simple NE602 receiver circuits (such as in Vectronics and Ramsey kits), however, certain diodes perform better than others.

The following circuit (values are for 80 meters) is an example of a VCO built using a MV104 varactor diode (available from Mouser, Digikey, etc.).

The MV104 varactor diode has two diodes in it, connected "back-to-back." Using two diodes in this way prevents the alternating RF voltage (in the oscillator) from driving the diode into "forward conduction" (that is, during one half of the cycle, the sum of the reverse bias and the RF voltage could go negative and the diode is no longer reverse biased). The downside is that you have two "capacitors" in series, so the total capacitance is cut in half.

In this circuit, the Main Tune (10k) variable resistor varies the reverse bias voltage on the MV104 in the VFO tank circuit. The elegance in this circuit is its over-

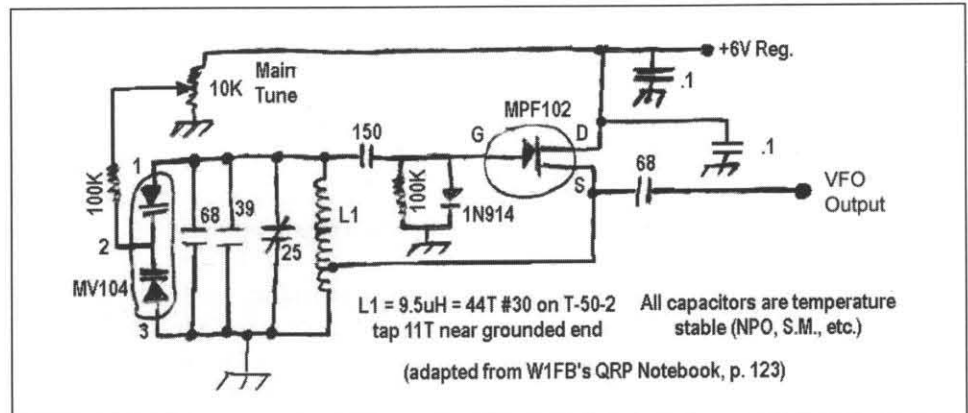

My hand-drawn diagram of a "classic" voltage-controlled VFO circuit.

all simplicity. However, such simplicity does come at a cost—for one thing, the variable capacitance changes over a range of voltages, normally in the range of 1 or 2 volts to about 20 volts; if your voltage falls outside of the range, the varactor will not perform properly (in the example VFO/VCO circuit, it is possible for the voltage to drop below 1 volt at the low end of the tuning range).

A scanner is simply a receiver that uses a VCO over a selected range of frequencies. Special circuitry varies the voltage applied to a VCO either in steps (e.g. "channels") or in a "ramp" (also called a "sweep"). The "scanner" component of the bandscope uses ramp voltage control, since HF frequencies are not channellized. As the voltage increases, the frequency increases in a (nearly) linear fashion.

## Measuring Signal Strength

Many simple QRP rigs do not have frills like Automatic Gain Control (AGC) and an S-meter. How is it, then, that even

without a visual indication of signal strength, you can send and receive RST reports? Well, to the ear, signal strength becomes loudness when transduced by a speaker (or headphones), and the ear is a fairly decent detector of relative loudness (1 dB is defined as the smallest perceptible change in loudness that the ear can hear).

Recovering a DC signal that is proportional to the signal strength from the detector stage of a receiver, and measuring it with a meter or other indicator, is one way to obtain a visual indication of signal strength (see the following diagram).

In this basic signal strength detector circuit, diodes, D1 and D2, form a voltage doubler that rectifies the audio energy coupled in via C1. The resistor, R1, (say, 1M ohm) and the capacitor C2 (say, 4.7  $\mu$ F) form an RC circuit—the larger the R (resistance) or C (capacitance) the longer it takes to charge and/or discharge the capacitor. The rectified current charges the capacitor to a certain level, depending on the signal strength of the signal, and as the

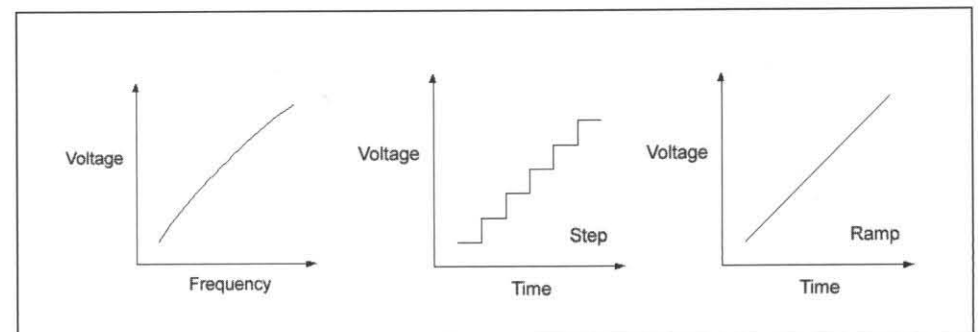

The voltage-to-frequency characteristic (left) of the VCO can be controlled by either a series of voltage steps (center) or a continuous voltage ramp (right).

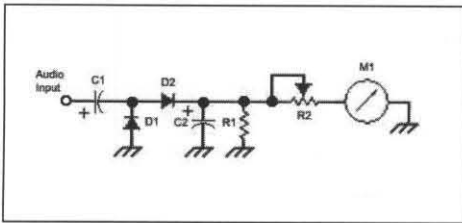

**A simple signal-strength measuring circuit (diode detector).**

signal strength drops, the resistor discharges the capacitor. The delay this introduces in charging and discharging serves to “smooth out” the voltage that is constantly varying, and keeps the needle from jumping around wildly.

The variable resistor, R2, limits the current going through the meter, M1, and is used to calibrate the signal strength indicator. The circuit can be connected directly to the audio output of a receiver, making

it a “signal strength” receiver. This device is useful to compare relative signal strengths, but does not indicate absolute received signal strength (since some radios might be more sensitive on some bands than on others). To make more practical use of this circuit as an S-meter in a receiver, you should include an isolation buffer (a unity gain amplifier with a high impedance input) followed by an audio amplifier, and connect it in the audio chain before the volume control.

#### Putting it Together

We now have two of the basic elements of a bandscope—a VCO and a way of measuring signal strength. Sweep the VCO over a fixed portion of the band, convert the RF to audio, measure or sample the signal strength over the sweep bandwidth, and plot the results (say, signal strength on a Y-axis and voltage or frequency on the X-

axis). Voila! You have a bandscope!

Ah, you say, but how do I sweep the VCO, and how do I automatically graph the resulting signal strength? Well that is, as Paul Harvey says, “the rest of the story.” It is actually quite simple using a ramp generator circuit and a Cathode Ray Tube (CRT). We’ll talk about that in the next installment of this column. Hopefully, you’ll begin to see that from some pretty basic and simple building blocks, we will build up a fairly useful piece of test equipment that will help us in all sorts of ways. Oh, by the way, that bit of bandwidth over which you sweep your VCO is also called spectrum—and so the technical term for this bandscope we’ve been describing is a spectrum analyzer.

But until then, let’s just grab a little bit of that spectrum and get QRV, shall we?

—72 de Mike, KO4WX



## Member Profile—RV3GM/QRP

Oleg V. Borodin—RV3GM

Lipetsk, Russia

As far as I can tell at the moment, I am the lone member of QRP-ARCI from Russia. I currently live in Lipetsk (KO92so), a large industrial metallurgical center located 400 kilometers south of Moscow.

I’m thirty-nine years old, married, and have two sons, one eighteen, the other sixteen years old.

I’ve been actively involved in Amateur Radio since 1976, beginning as a short-wave listener (SWL). Ten years later, in 1986, I received a radio license as UA3GVR. In 1989, I upgraded to an extra-class license and received RV3GM, the call sign I now use.

Although the new license allowed me to operate at much more than five watts, I still operate only CW and only at QRP power levels. My current favorite power is two watts of output, and the majority of my QSO’s are conducted at this power level. At present, I have worked about 80 countries toward the completion of a DXCC, have worked all continents, and I have also obtained a QRP-Master Trophy from the G-QRP Club.

Because of some problems, I was QRT for several years, and I am really enjoying a return to my favorite hobby, QRP radio.

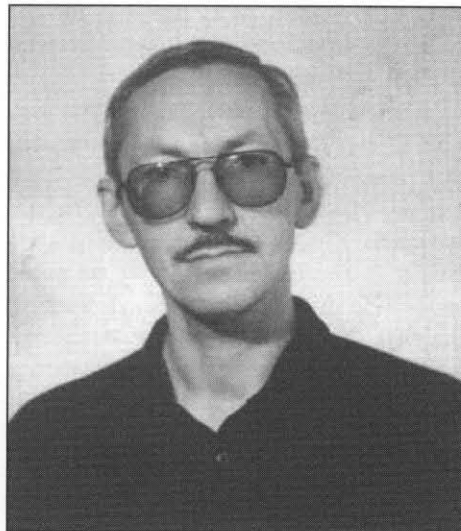

**Oleg Borodin, RV3GM/QRP.**

I am also glad to see that the special code “72” has been supported by the G-QRP Club and that it is frequently used by QRPers all over the world.

The equipment used here is simple, consisting of a NorCal-20 transceiver with two watts of output to a longwire antenna. I also have a small collection of QRPp DC-VXO transceivers, including the Micro-80 and the Tiny Tornado that I use for the 80,

40, 20, 30, and the 10 meter bands. These small radios have a power output that ranges from about 100 mW all the way up to 500 mW.

I also have a wide-band broadcast receiver in my shack that does double duty. I have improved this receiver by added an IF-oscillator with product detector to allow it to receive CW/SSB. Connecting this same receiver to my computer gives me PSK-31 receive capability, and my near-term plans are to build a transceiver similar to the PSK-20 so I can operate the PSK mode.

In the near future, I will be organizing a Russian QRP Club and I am currently organizing a regular, weekly, World QRP Round Table that will meet at 14.060 on Saturdays at 10.00 and 22.00 UTC.

I consider myself successful as a Ham, and hope to leave my own small track in the history of Amateur Radio.

I wish all the best for all you out there, and I’ll be glad to meet you on, or near, the regular QRP frequencies.

—72! From Oleg, RV3GM/QRP

...and welcome to the QRP Net on Saturdays!



## Milliwatting—30M QRSS Beacon Activity

Jim Hale—KJ5TF

[kj5tf@madisoncounty.net](mailto:kj5tf@madisoncounty.net)

Late this winter I started to notice some postings on QRP-L by Paul Stroud, AA4XX. He and some other extreme QRPers were running something called QRSS beacons on 30 meters. While Paul brought all this to QRP-L, the QRSS 30 meter experiments were actually initiated by Johan, ON5EX. To me, this sounded like a fun thing to do.

With QRSS, a CW signal is sent very slowly, and repeated. Paul would choose a code word and start his QRSS beacon on schedule at a set power. Listeners tune in and copy the code word, and log a signal report. Then, at a set time, Paul would reduce power and start the beacon again.

This would go on for a preset duration, and in a few days they would start again.

For Paul's AA4XX/B station, QRO is 500 mW, and he uses a dipole antenna. I was interested in knowing more about his operation, so I followed the links Paul posted in his messages, and downloaded a copy of ARGO.

<http://www.qsl.net/padan/>

ARGO is a powerful DSP audio analyzer that uses your computer's sound card. To copy a QRSS beacon, you simply connect your RX audio to the sound card input jack on your computer, fire up your radio, start the software, and tune into the preset frequency. The idea is that if you watch the waterfall, have a narrow bandwidth, and are properly centered on the correct frequency, you have a long time to look for signs of a signal.

With QRSS10 it takes 10 seconds to send a dot and 30 seconds to send a dash, and QRSS is popular in some Earth-to-Moon and LowFers experiments. Paul mentioned in his postings that QRSS30, 60, or 120 can be copied at levels as far as 30 dB below the noise floor.

While that's simply amazing, when I copied AA4XX/B running QRSS3 it was really hard to sit still for long enough to record the 4 letter code word!

That's not to say that I didn't enjoy it, because I did. But working with CW that is coming that slow is really a challenge. As you decode the visual signal on the screen,

the mind tends to wander around the room, and before you know it you've looked away from the screen. When you look back you wonder if you missed anything, and so it goes until the code word has been copied at least twice to be sure.

To show just how effective this can be though, while running QRSS10, AA4XX/B was logged by ON5EX, Johan, in Belgium, and ON6UL, Luk, also in Belgium, with only 2.5 mW. In a mid week session, running only 500 uW, correct code words were copied by the following, N4SO, Ken (AL), AE5K, Don (AR), WØCH, Dave (MO), and ON5EX, Johan, in Belgium. All in all, a pretty amazing experiment, and I hope I can join in again some time in the future.

They also did some experiments on 30 meters using the Slowfeld digital mode. I think this is a faster way to go, but I didn't catch the results on QRP-L, so I can't report on that mode this time. If interested, visit the following webpage to download the G3PPT SlowFeld freeware program:

<http://www.muenster.de/~welp/sb.htm#rtty>

To keep up with these extreme QRP experiments, check out the following links. There is a list that you can join too, and really be in the thick of it. Most things have peaks and valleys, so I'm sure new blood is always welcomed.

For full information on QRSS have a

look at these websites:

<http://www.qsl.net/w0ch/qrss/qrss.htm>  
<http://www.usssc.com/~turner/qrssl.html>

Yes, there is a QRSS list. Anyone interested in subscribing to the QRSSKnights list just needs to send an email to: [qrss@cmts.be](mailto:qrss@cmts.be) A message will then be sent back to the sender with details on how to send messages to the list.

Here's a list of some of the more notable 30M QRSS contacts in recent weeks:

ON5EX and AA4XX/B — 500  $\mu$ W QRSS beacon

AA4XX and WØCH/B — 10  $\mu$ W QRSS beacon

WØCH and AA4XX — 100  $\mu$ W QRSS60 2X QSO

ON6UL and AA4XX/B — 1 mW QRSS beacon

VK2ZTO es DF3LP/B — 350 mW QRSS beacon (approx 24,000km path distance)

I didn't calculate the miles per watt on these. But they must be close to some kind of a record.

—Jim, KJ5TF ●●

### Do YOU enjoy milliwatting?

Let Jim know what you have been doing...

"Personal best" miles-per-watt  
What kind of rigs you use  
Modulation: CW, PSK-31, QRSS or ?  
Low Bands, High Bands, VHF/UHF  
How active you are on the bands

E-mail: [kt5jf@madisoncounty.net](mailto:kt5jf@madisoncounty.net)

# Ramblings of a Peaux Cajun Lad at FDIM

Joel Denison—KE1LA

hamjoel@juno.com

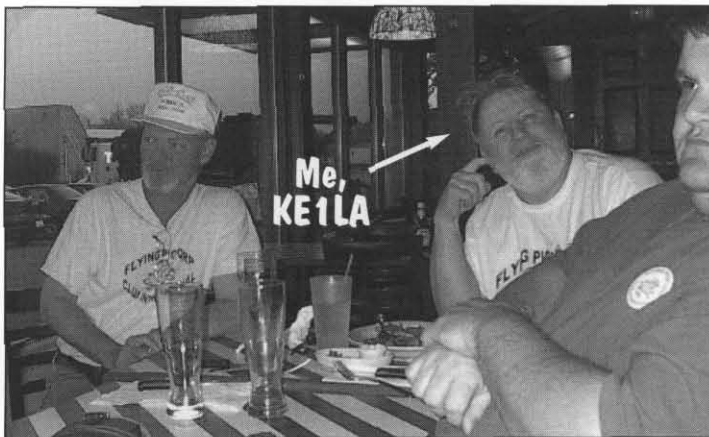

**H**igh Y'all! Kinda bare with me heah...I'm still trying to understand FDIM...seems thair is Hamvention, FDIM, Flying Pigs, all at the same time almost...

Kinda like going to a triple wedding of twins and then trying to find out who married who after averybody done got themself drunk...

On the FDIM thingie....somebody worked hard, cause it went smooth as silk...ah got to see all kinds of big wheel type folk... even rubbed shoulders with Chuck Adams, and Ed Hare, and Adrian Weiss....to only name a few....wow man...

The kit building program was a blast...and the results just beautiful...them folk built some nice what meters... and most of all....dey all had fun...

And the homebrewing process was truly amazing...such beautiful radios...and utter thingies....oh and the talks, man I tell u...I could kinda follow most of them however some was over mah head...

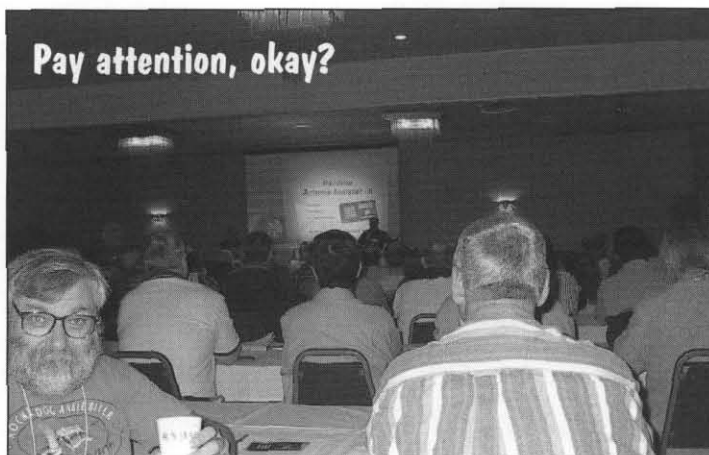

Course the piggies had a Q and Drink session....great pork and beer guys... thanks...and the awards banquet... Tom had his hands full with the board up thair and the hall of famers...Man when it come to being somewhere where they was knowledgeable folk....fdim was in high cotton...then u could run ovah to hamvention and take in the sights or talks, when fdim had a rest period...

The onlyest time ah can remember that many folk gathering together and laughing and learning sew much was the Boudreaux family reunion back in Louziana....



The craziest thing what ah saw was the flying pigs getten one of thair own to talk at the banquet for five minutes...I understand the speaker took 20 minutes or so...them Mike an Tom pulled him from the mikephone and sent him back to his seat...and both of them are piggies... No respect I tell u, no respect... :-)

My memory is about as good as a three dollar bill, so bare with me darlin...oh, ah wants to say high to Jill... Understand she bees a beauty queen...a real southern belle...Don't got me wrong now, I ain't calling her a ding a ling...only the real thing...like the cola....Ur hubby walked the line at fdim, Jill ... u done picked a gud man...



Gots to say THANKS to Mike Hall. He made it possible for me to be thair at fdim and he done treat me like ah was royalty....some bodies musta paid him one hades of a lot of money to put up with me 4 days...

Whoevers what done the ground work for the very first FDIM can rest asured that thair early tradition is being carried on with what folk that be doing FDIM now...

U kneaux, I discovered qrp folk be lots different from qro folk...seem to bees meaux patient and understanding and just

sumthin about them sets them apart...sure was a pleasure getting to kneaux u folk...

Oh we missed the net on wed nite, mostly due to fatigue...U gotta remember u start FDIM out like a ball of fire, and just like on ur honeymoon, U seem to burn up all the fuel before u kneaux what done happened....

So From this cajun's point of view.... FDIM bees like a great big four day crawfish boil and party...no weigh u gonna come outta dat without meaux fun than what u could imagine... Really, it's that good...

—72 de Joel, KE1LA



### Meaux FDIM Pictures:

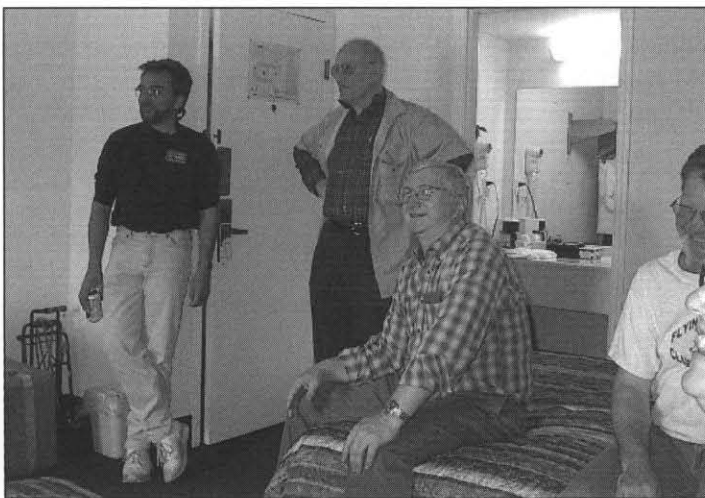
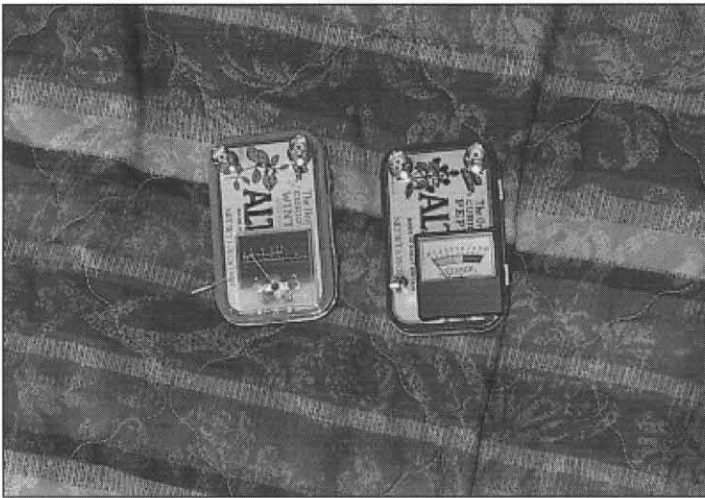

# Review: Logikit CMOS-4 Keyer Kit

Tom Hammond—NØSS

n0ss@earthlink.net

I love building kits, especially electronic keyers, but one of the least enjoyable facets of building electronic devices (for me anyway) is having to scrounge difficult-to-find parts, or components which aren't hard to find, but which I can't obtain locally. It always seems I wind up having to go to more than one vendor, and end up paying a lot of cash for shipping and (in some instances) "handling." Then you have to determine what type of case you want to use (it'll almost always be too big).

And don't forget the pain of going from place to place, trying to find acceptable pushbuttons for the message buttons. The switch must:

- Be easy to actuate, but not too easy.
- Give you a bit of tactile feedback, so you'll know you really did press it.
- Be small enough to fit into the case.
- Be easy to install.
- Most of all, be reliable and not prone to becoming noisy after only a short life span.

Idiom Press has produced CMOS Super Keyer kits for a bunch of years... more than I can remember anyway. The problem was that their "kit" only included the PC board and all of the parts that mounted on the PC board. But that was it... none of the other required parts were included in the kit, leaving it up to the builder to decide how he wanted to outfit his keyer, and then to go find all of the missing parts.

Most of the missing parts could be found at the local Radio Shack, but you could not find reasonably priced pushbuttons there! By the time I bought all of the remaining parts at The Shack, I had invested a total of about \$85 in the complete list of parts, and sometimes this still didn't include the case. I loved the keyer, but hated the parts search.

Well, Idiom Press/Logikey (AKA Bob Locher, W9KNI) finally did it! They've come out with a new keyer kit, aptly dubbed the "LogiKit CMOS-4."

It's a complete (!) kit, including all required components, a killer case, and a

set of tactile pushbutton message switches, all for very nearly the price I was having to pay for the old kit plus individual parts from R/S.

I am fortunate in that I was able to field test what I think was only the second LogiKit CMOS-4 ever produced. I also got to help proof the assembly manual as well, and although I still haven't seen the User Instruction Manual, I do know it has been printed. Assembly of the kit went without a single hitch—everything fit where it was supposed to, and all parts were provided—nothing was missing.

The assembly manual has you first install the monitor speaker onto the bottom half of the keyer case. Then you install the connectors, which also mount onto the bottom of the case. There are only three connectors to mount: external DC input (5.5mm x 2.5mm coaxial jack), paddle input (1/8" stereo jack) and keyer output (RCA jack). The installation of the DC power connector was a bit "tight" since there was little "wiggle room" between the jack and the speaker. But the manual offers easy-to-follow steps to simplify the installation of the power jack.

From there, you begin installing components.

First to be populated is the pushbutton mounting board. It gets four (4) small PC board-mount tactile feedback pushbuttons with pushbutton caps about 1/4" in diameter. The buttons are arranged in two groups of two, and have a nice solid "feel" to them.

Next to be populated is the main (keyer) PC board. Parts installation goes logically, and builders should experience no problems with assembly of the PC

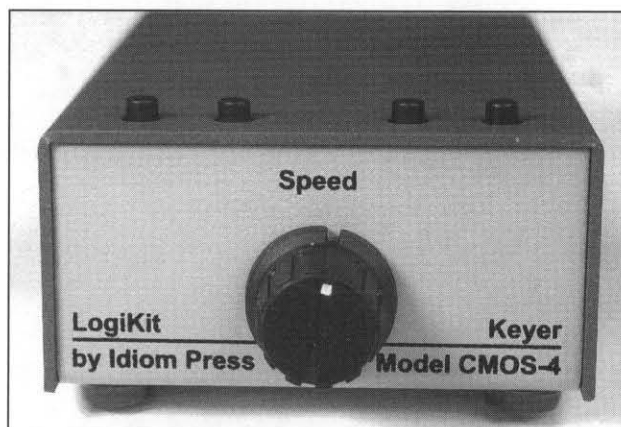

The LogiKit includes an attractive case for a professional finished product.

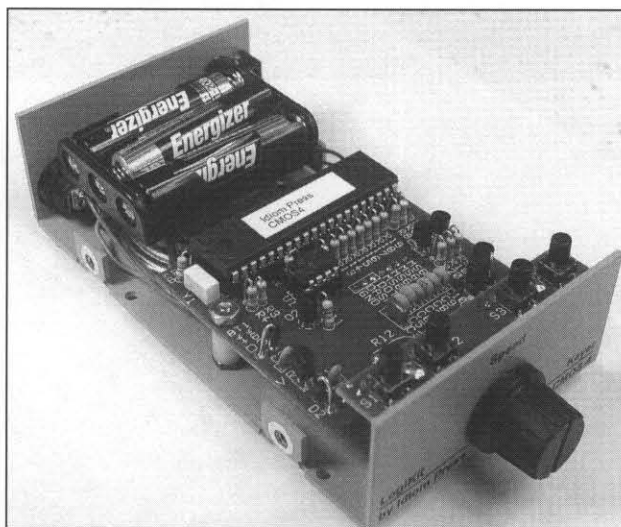

Inside view of the completed LogiKit CMOS-4

board.

Final assembly consists of attaching the main and pushbutton PC boards and connecting the few wires that attach to devices not on the PC board.

The most difficult part of the entire (approximately three hour) assembly was soldering one of the leads to a lug on the speed control pot that is quite close to the bottom of the chassis and difficult to access. If I build another one of these kits, and I may well do so, I think I'll attach the speed control wires to the pot before I mount it to the front panel.

Final assembly was a snap. The two halves of the case fit together like a glove



(similar to cases made by that "E-something" company...).

Operationally, the LogiKit CMOS-4 performs just like its older siblings. It's silky smooth to send with, easy to program, and keys either the positive key-lines of modern transceivers or the grid-blocked key-lines of many of the older rigs as well. CW speed is between 5 and 60 WPM, with an additional "high speed" range of 70-990 WPM for meteor-scatter ops. Yes, you read correctly—all the way up to 990 WPM!! For us mere mortals, who can no longer copy (or send) 990 WPM, you have the ability to select a user-programmable speed range. I chose 18-40

WPM, but any combination of two speeds between 5 and 60 WPM are available to you. And, unlike some other keyers, the Speed Control is linear. Weighting is fully adjustable from 25% to 75%, with 50% weighting being the default.

The keyer also includes keying compensation, to make up for the small (millisecond) delay between when the key is hit and the output arrives, which often results in a slightly "lighter" than normal character. It appears the best compensation for my K2 is between 2 and 4 mS—almost not required.

The monitor speaker has ample volume, and a volume control is provided on

the bottom of the case to adjust it to the desired listening level.

There are many more features of this keyer, but it would take too long to list them here. You can read about them on the Idiom Press web site at: <http://www.idiompress.com/cmos4.html>.

In short (too late for that now, Tom), this is just the keyer I've been looking (and hoping) for. 'Bout time! Thanks Bob.

I have no financial interest whatsoever in Idiom Press—I just happen to like their products.

—de NØSS

●●

## NoGa Donates K2 to Science Museum

Pickett Cummins—AD4S

[jpummins@netscape.net](mailto:jpummins@netscape.net)

The North Georgia QRP Club, "NoGa", along with the Atlanta Radio Club recently presented the "hands on" science museum, Sci-Trek, in downtown Atlanta with a brand new, complete Elecraft K2 transceiver. Elecraft also graciously helped with this project.

NoGa had been looking for a lasting and productive project to apply their excess kit funds to and Pickett, AD4S, proposed this project and arranged for the component acquisition and building/installation completion.

NoGaNought, Joe, W4JHR, volunteered to build the basic K2 and coordinate the installation of the optional components. Joe also built the SSB option. Assisting in the option building from NoGa were Guy, AF4MN, who built the antenna tuner and Tim, WD8DRM, built the audio filter. David, KG4LSK, from ARC built the noise blanker. The construction work was of the highest caliber and everything worked the first time it was powered up.

A web album of this project can be seen on the NoGa web site at [www.nogaqrp.org/projects/scitrek/scitrek.html](http://www.nogaqrp.org/projects/scitrek/scitrek.html)

The Sci-Trek Amateur Radio Station (STARS) has it's own call sign; W4WOW. You can check out the Sci-Trek web site at [www.scitrek.org](http://www.scitrek.org) and look for the STARS link on the bottom of the "Permanent Exhibits" page. ●●



Joe, W4JHR, getting ready to install the final options.



An engraved plaque was put under the front speaker screws so that no damage was done to the K2 case.



This is the official presentation. L/R are Doug, STARS Station Manager, Jim, W4QO, guiding light of the entire STARS project who received the K2 on behalf of STARS. Making the presentation were Penn, K4PE, President of ARC, NoGaNoughts, Joe, W4JHR who did all of the hard building work and Pickett, AD4S (right), who initiated and coordinated the project.

# Let's Talk About Contest Logging Programs

Randy Foltz—K7TQ

rfoltz@turbonet.com

In my job as QRP ARCI Contest Chairman, I see every log and summary sheet that gets turned in for scoring. A few are hand written on notebook paper, and a few more have been retyped into a word processor or a spreadsheet. Most, and certainly those with lots of Qs, are the result of using special contesting programs. With the help of a few users (and often the program author), I'll discuss the ones that I see used most frequently in our contests.

First of all, why use a contest logging program? To me it boils down to convenience. I don't have to keep a dupe sheet (a list of stations contacted) and I can take a little break while the computer sends CQ or the exchange. During the contest, I get a visual picture of the multipliers I've worked and those I need, as well as a running score. Finally, at the end of the contest in five minutes or less, I've got complete results, a well formatted log and summary sheet, and several reports that review such things as rates per hour and multiplier distribution. After getting over the fright of having the computer do all the record keeping and sending, it simply makes the contest more enjoyable for me. I'm sure other logging program users have similar thoughts.

We could get into a long debate over the features that a first class contest logging program should have. However, we will stick to the basic requirements. First of all, it should do the two most time consuming things in a contest—record keeping and dupe checking. In the record keeping category, I include recording the date, time, band, station worked, and both received and sent exchanges. These are the things you keep on your paper log during the contest. It should also be able to quickly, and with only a few key strokes from you, determine if a station is a "dupe" (you've already worked him). In some contests, such as all QRP ARCI contests, this must be kept on a per band basis. In others, such as Sweepstakes, it is a work only once operation. The dupe checking is what separates general logging programs from contesting programs.

I've got four items in my expanded list of basic logging programs. The ability to key the radio is a valuable additional fea-

ture. This eliminates the need for either a separate keyer or using the rig's keyer. If the program is going to key the radio, it needs a variety of "canned" messages. Ones that come to mind are the exchange, a repeat of the exchange for fills, some type of "thank you and good bye" message, and various messages to request fills from the station being contacted. In a slow paced contest, like many of the QRP ones are, a "canned" message that sends CQ sure is useful. A running tally of the score helps keep you motivated when the answers to your CQ s get far apart.

Another motivator is a running tally of what multipliers you've worked and those you still need. This tally also provides a reminder to move stations to other bands. For a little icing on the cake we can throw in computer control of the radio. It isn't necessary, but it sure is neat!

Given the first two features and a few of the next level down, I think you've got a very useable contest logging program. In the contesting world the popular ones are TR Log, NA, and CT, with WriteLog gaining in popularity. I'll focus on only those that I've had some experience with, or know a QRP operator that has used them. The list of PC-based programs I'll discuss includes TR Log, NA, QRP Dupe, and N3FJP QRP ARCI Contest Logging Program. For portable operations I've selected two, Golog and qrpLog, although the last one is not a contesting program.

## TRLog

TRLog was written by Larry Tyree, N6TR/7. It is one of the full featured contest logging programs and runs in DOS. Of the seven items I listed above, it will do all of them and a lot more. The big feature of TRLog is "mode" sensitive action. In this case, mode means whether you are CQ-ing or Search and Pouncing (S&P-ing). Let's say you have the program tied to your radio via the COM or the LPT port so it can key the radio for you. Let's also say that you are CQ-ing and you hit the return with the cursor in the currently empty call sign window, then the program will send CQ. A station comes back to you and you enter his call and hit return. If you have not

worked the station, your exchange is sent and the cursor advances to the window where you type in his exchange. Upon a successful completion of the exchange, a "thank you now good bye" message is sent, and you're back to CQ-ing. If the station is a dupe, the canned message that "you are a dupe and good luck in the contest" is sent and you're back to CQ-ing. TR won't let you "fake" the exchange. If the exchange is RST, SPC, and Number as it is for our contests, you must enter a valid SPC abbreviation and a number less than 99999 or you won't get out of the exchange box. (RST can default to 599 or 559, if you tell the program before hand).

A slightly different sequence of operations takes place if you are S&P-ing. Rather than sending a solicitation CQ, your first action is to type in a call that you want to answer. If you've already worked the station, the program will beep, flash a DUPE message on the screen, clear the call sign window, and await for you to enter the next call sign. Nothing has gone out over the air. Didn't waste your time or his. If it wasn't a dupe, the program sends your call and moves to the exchange window. When the stations answers, you type in his exchange and hit the enter key. Your exchange is sent and you are returned to the call sign window waiting for your next Search & Pounce victim. Again, you've got to get the correct format for the exchange or you don't get to log the call.

For both modes, there are "canned" messages to help you with asking for fills and giving fills. There is one key that allows you to use the keyboard to type and send messages. The "F" keys are assigned various messages. Because this is a DOS program, and probably because Larry doesn't like mice, you never have to take you hands off the keyboard to use the mouse.

There are windows that show which multipliers you need and those you have worked. Another window shows the current score. Yet another shows the last five QSO log information. There are a couple of rate windows, and each of these "windows" is a character based DOS-type window.

The program contains a CW contest

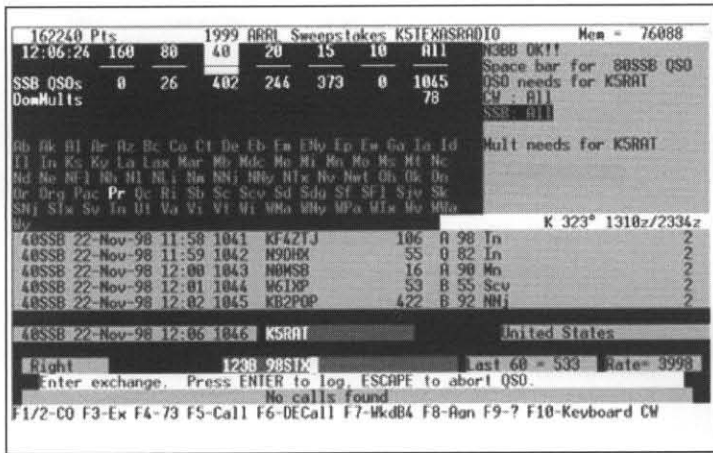

Screen shot showing TRLog in action.

simulator. In it, you CQ and the programs will answer from its own selection of real calls or use real calls that you've stored. Exchanges are sent and you've got to receive them correctly—well at least it checks the call sign, or you get zero points for the contact. If you think you've got the call sign correct and try to log it, but the program knows you didn't get it correct, you get a CW message that says "NO YOU HAVE MY CALL WRONG. IT IS K7TQ." The simulator is a really fine way to get comfortable with the program and with the fast pace of contesting.

This one is my favorite, as you might have guessed, and I could go on but there are others to cover. Just a final note on TRLog. I've often read that TR has a steep learning curve. Maybe, but the payoff for hanging in there is well worth the effort. The web page for TRLog is <http://www.qth.com/tr>.

The second logging program I'll discuss is NA. NA is one of the full blown, many features contest programs, and I see many QRP ARCI contest entries that have used this program. Like TRLog, it is a DOS program. N4BP is an ardent user of NA, so I asked him to write about it.

#### NA (Described by Bob Patten, N4BP)

Dave Pruett, K8CC, wrote NA to fill the void for domestic contests created by the first sophisticated computer logging program, CT. The appearance and key strokes used closely resembled CT to make the transition to this software as easy as possible. Over the years, both CT and NA have expanded to each support both domestic and DX contests. I've experimented with both, but found NA to be

more "user friendly" and better supported by its author.

While TRLog is probably more configurable than NA, it is more complicated to set up and use (steeper learning curve). NA does include a "Template Editor" which gives the program a limited ability to log contests not directly supported. Using TE, I've been able to use NA to log any of the various QRP club sprints like QRPTTF, BUBBA, FYBO, and QRP Afield. Several of these sprints do require some post editing to calculate the score, but the logging and dupe checking functions always work perfectly. NA does directly support the QRP ARCI Spring and Fall Parties, and with some persuasion, the author even expanded the Member Number Field to five characters when QRP ARCI member numbers passed the 10,000 mark.

NA provides computer control for any of the commercial transceivers that have provision for it. Even the Elecraft K2 works well when NA is configured for "KENWOOD1." In addition to the K2, I use this feature with an FT-1000MP and IC-706MKII. Using either a COM port or LPT port, NA provides keying for a transmitter. It also has a built-in software keyer that is operated by plugging a paddle into either a COM or LPT port (same port used for keyed line output) and exactly matches the speed of the pre-programmed messages.

Even the newest versions of NA will run on anything from an old 8088 CPU all the way to the latest Pentium chips. It will use any expanded memory that it finds available to log up to 16,000 QSOs in most contests (I've never hit that limitation—YET !?). To illustrate the extremes, I've

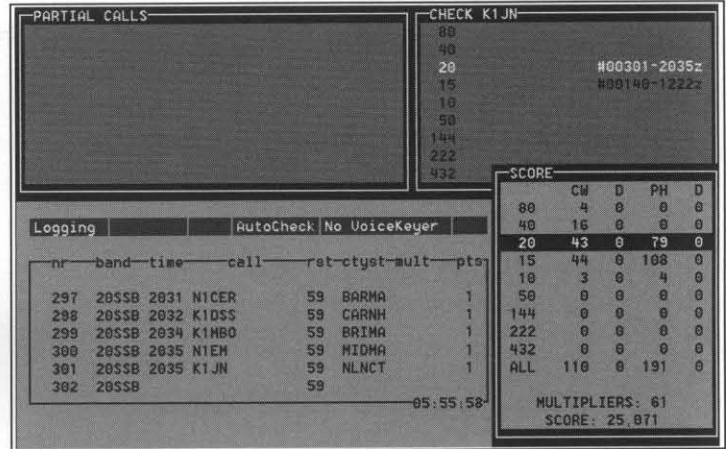

This screen shows NA's display setup.

used NA on a Poqet notebook (8088 CPU) and more routinely on a K6-2/450 desktop. Of course it runs faster on the desktop, but if "Supercheck Partial" is disabled, it runs just fine on the little Poqet.

There is a demo version of NA available on the DaTom website (DAve and TOM Pruett have shared in the writing of NA and its support software). The URL is: <http://www.datomonline.com>

Both Bob and I have attempted to give you a feel of what using a computer logging program is like. The programs described below follow in a general way what we have described above. Rather than repeat these descriptions for each of them, I've chosen to let the authors focus on what makes their programs unique.

In January of this year, I received an e-mail from Scott Davis, N3FJP. He was starting to write a Windows-based logging program tailored specifically to QRP ARCI contests. After a couple of iterations, he came out with N3FJP QRP ARCI Contest Logging Program. I gave it a whirl, and found it intuitive and quite easy to use. It does all the things I listed above except for radio control. In the Spring QSO Party I noticed a handful of users of this program, and I have asked Scott to say a few words about his program.

#### N3FJP QRP ARCI Contest Logging Program (Described by Scott, N3FJP)

N3FJP's QRP ARCI Contest Logging Program is an easy, efficient, and fun to use Windows based application designed for the following QRP ARCI contests Fireside SSB Sprint, Spring QSO Party, Hootowl Sprint, Summer Homebrew

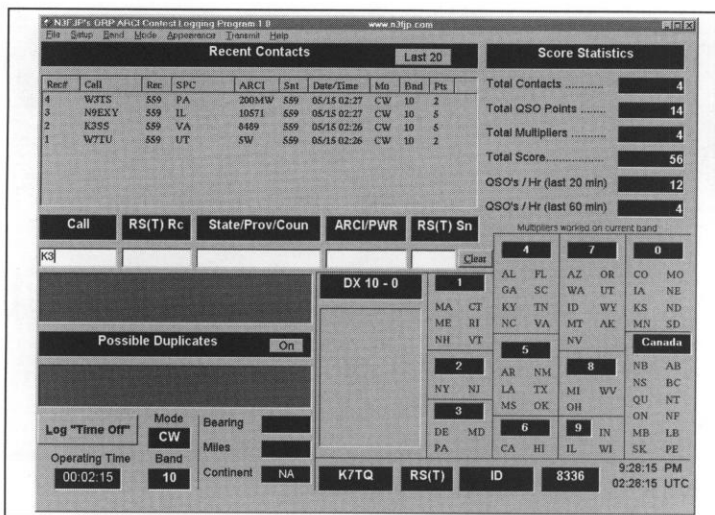

This is N3JFP's QRP ARCI Contest Logging Program.

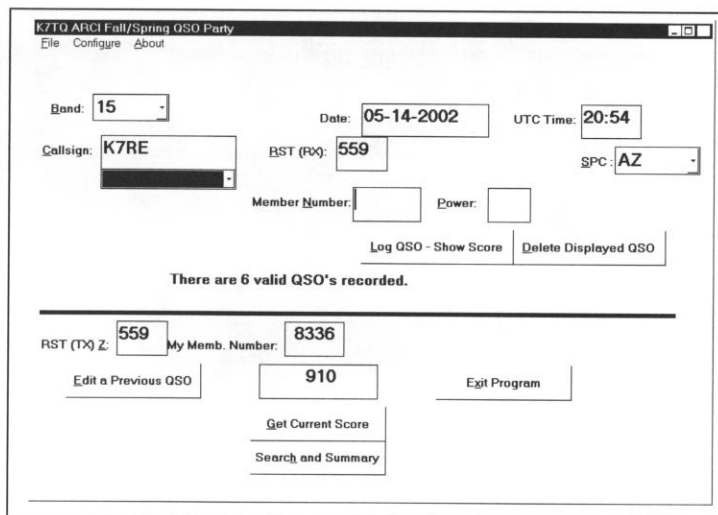

QRP Dupe's screen looks like this.

Sprint, Fall QSO Party, Holiday Homebrew Sprint, and Top Band CW & SSB Sprint.

The program checks for duplicates (including partials), lists all contacts, lists multipliers by band, provides a country look-up function, writes files for contest submission, and provides many current statistics. It can also be used to generate CW (via RTS or DTR comm lines) and voice (via sound card).

N3JFP's QRP ARCI Contest Logging Program is free to try and fully functional for 30 contacts. The registration fee for full use is only \$10. Please visit <http://www.n3fjp.com> and check out the software.

In the April 2001 issue of the ARCI *QRP Quarterly*, I featured Brian Kassel, K7RE. In that article, we talked about his contesting program QRP Dupe, and he said it was "a beginner's contest logging and duping program." I've asked Brian to expand on those comments.

### QRP Dupe (Described by Brian Kassel, K7RE)

This program was developed with just one goal in mind: To provide a very inexpensive contest logging application that is simple to use, and requires no configuration other than typing in your call sign, name, etc. Updates will be available for each of the QRP contests, as well as many of the more popular contests that include a QRP category.

CW send capabilities that use a simple serial port interface and synced to the operation of this program are now includ-

ed. Thanks to Brian AE9K for this feature.

Minimum system requirements for the CW send feature are a 486-66 or better. The logging portion will run satisfactorily on a 386-20, and perhaps a bit less. Windows 3.1 or above is also required.

This FREE BETA Version program is intended to allow prospective contest operators to enter the world of QRP contest operating with a minimal learning curve. Take a look at <http://members.dancris.com/~bkassel/index.htm> for more information.

That completes the PC-based logging programs I see most often used in QRP contests. Let's shift gears a bit and talk about the world of Palm-based programs. The two I'm most familiar with are Golog and QRPLog. I was in on the beta testing of some portion of both of these and found they each have a unique niche.

### Golog

In the same April issue with Brian, there was an article by David Ek, ABØGO (now NKØE), about using a Palm and a PIC microcontroller for contest logging. His program is called Golog. It stuffs most of the usual contest logging information onto a single Palm screen, and in spite of this compact requirement, it is easy and intuitive to use. It doesn't keep a running score or show multipliers, but does a great job of log keeping, dupe checking, and keying the radio. It also has a decent selection of "canned" messages for fills and thank you's. If you are an experience Palm user, Graffiti, the Palm handwriting recognition language, shouldn't be too much of

a problem. I used the program for a Spartan Sprint and my Graffiti skill level was just about right. The CW Sender utilizes a PIC16F84 microcontroller to key the radio. This frees the Palm programmer from having to worry about proper timing of the LPT or COM port handshaking lines that are used to key the radio. Since the April 2001 issue, David has included the ability to send CW with a paddle plugged

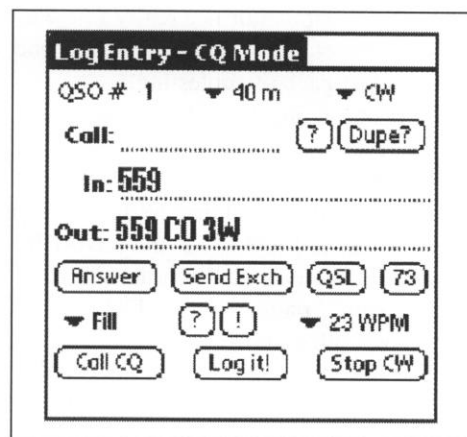

Golog fits this data on a Palm handheld PC.

into the CW Sender. The following is borrowed from David's web page:

Golog is a contest logger for Palm OS® and was written with the QRP field contester in mind. Golog is small (about 48k) and simple, and should run on any handheld computer running Palm OS version 3.0 or newer (in fact, it may run on versions as early as 2.0, but this hasn't been tested). Golog performs the standard contest logging functions, including duping, and can be set up for any contest.

GOLog includes a conduit for Windows-based PCs so that your logs can be transferred from your handheld computer to your PC in text form. Unfortunately, no support exists for Mac, Linux, or other platforms.

The other Palm based program is not a contest program, but has many of the features of one. QRPLog written by Jim Gelbort, N9WW, can keep logs, and with a few extra key strokes, do log searches (sort of a poor-man's dupe check). Here is what Jim had to say about his program.

**QRPLog** (*Described by Jim Gelbort, N9WW*)

Modern computer logging programs are great, and enable many operators to increase their contest Q rates, control a rig from the keyboard, track a zillion different awards, print QSLs, and operate digital modes in addition to plain, old log-book maintenance. But what are your choices if you step away from the shack for mobile, vacation, or field operations? You can always lug a laptop. Or rely on paper and pencil, then manually input those traveling QSOs upon your return. I chose a different approach, one patterned on the way so many of us jot notes, make appointments, or update an address book on the fly, then synchronize that information with a home or office computer. Yes, the popular Palm organizer, or any of its cousins, is the perfect solution for portable amateur radio logging, and qrpLog is an application I wrote specifi-

cally for the QRP community.

As a general-purpose logging program running on a quarter-pound handheld device, qrpLog will not perform many of the fancier tasks you expect of your desktop system. It will efficiently and unobtrusively handle the primary aspects of logging contacts, including entry, edit, storage, and display of time, date, call sign, band, mode, RST sent and received, op name, QTH, and notes for each QSO. Browsing through your contacts is easy with the scrolling table showing date, call sign, band, and mode. This list may be filtered by band and mode. Tapping any displayed QSO brings up a view of the contact details, and one more tap permits you to edit the current QSO entry or initiate a new one. In addition, you may assign each QSO to a user-defined category and organize your log with these custom categories, just as you might with the device's built-in Date Book or Address Book applications. QrpLog also supports the global Find function built-in to the Palm OS. With this feature, you rapidly search for any prefix or call sign even when qrpLog is not running.

Contact data is entered by a variety of techniques depending on the type of information. Date and time are automatically recorded when a new QSO is initiated, but are user-editable. Callsign, signal reports, name, QTH, and notes are manually entered via your choice of Graffiti handwriting recognition or the built-in pop-up keyboard. Band and mode are selected from a list. You may set the appropriate

UTC offset, as well as default band, mode, and RST. When you return from your mobile or portable excursion, it is a simple matter to export your qrpLog QSOs into a desktop logging program. Just place your handheld into its cradle and press the HotSync button. Your contacts will be saved to your computer in ADIF format, the universal QSO interchange protocol, and may be read by nearly any other logging application.

This application is available for free to any member of QRP-ARCI. To request a copy, please visit this website—<http://home.att.net/~n9ww/>—or email me at [n9ww@arrl.net](mailto:n9ww@arrl.net) specifying which handheld model and desktop operating system you use. The ADIF export function requires a computer with Windows98 or later and Palm Desktop 4.0 installed, but qrpLog itself will run on devices with Palm OS version 3.1 or later. I welcome any comments, questions, or suggestions and hope that qrpLog will add to your QRP experiences.

That completes the discussion of the four PC-based contest logging programs and the two Palm-based programs. If you haven't tried one of these, give it a try. After the initial shock of getting used to the computer doing things, I think you'll find it increases your enjoyment of contest operating. Each of the URLs above will be on the ARCI Contest Web page at <http://personal.palouse.net/rfoltz/arcitst.htm>

—K7TQ

●●

## QRP Contests are FUN!

*Mark Your Calendars:*

*2002 End-of-Summer PSK Sprint  
September 8, 2002*

*2002 Fall QSO Party  
October 19-20, 2002*

# 2002 FYBO Results

Bob Hightower—NK7M

nk7m@extremezone.com

## 2002 FYBO RESULTS—BY TEMPERATURE

(see who the *really* crazy folks are!)

Callsign	Category	QTH	Score	Low Temp	QSO Pts	SPCs	Location
N1QS	Field - MO	VT	133,632	5	87	32	Western slope of Mt. Mansfield
N9NE	Field - SO	WI	400,416	8	194	43	Abandoned industrial land
N7CEE	Field - SO	AZ	62,016	9	34	19	Kendrick Park, north of Flagstaff
W1SA	Field - SO	VT	50,688	14	44	24	<a href="http://www.wcvt.com/~alank/fybo1.jpg">www.wcvt.com/~alank/fybo1.jpg</a>
NØUR	Field - SO	MN	536,448	15	254	44	Parked in the middle of Eagle Lake
NX9Z	Field - SO	WI	60,000	16	50	25	???
AA5B	Field - SO	NM	335,232	17	194	36	Sandia Mountains, east of Albuquerque
NØHJ	Field - SO	CO	23,040	17	30	16	Mt. Herman, near Monument, CO
NØTU	Field - SO	CO	15,552	17	27	12	Mt. Herman, CO, 9064 ft. ASL
WQØRP	Field - MO	MN	255,360	18	140	38	Parking lot
KIØII	Field - SO	CO	61,440	18	32	20	"Back 40"
KG5N	Field - SO	CO	53,856	18	51	22	Field near Las Brisas Observatory
WD7Y	Field - SO	NV	88,704	19	77	24	In the "van tent"
N8KV	Field - SO	MI	25,200	20	35	18	Ice fishing shelter
W1PID	Field - SO	NH	720	20	4	4	???
K8UO	Field - MM	MI	127,280	27	74	43	Metro Beach, Lake St. Clair
W8PIG	Field - MO	IN	86,400	27	72	30	Mounds State Rec Area
N3XRV	Field - SO	PA	144,720	28	67	27	Woods behind house
WD7Z	Field - SO	NM	75,600	28	70	27	Cibola Nat'l Forest (nr Albuquerque)
K8JV	Field - MO	MI	16,720	28	38	22	Local park
AB7TT	Field - SO	AZ	3,600	28	10	9	Snow slope at 9,000 ft.
K7TQ	Field - MO	ID	43,520	29	34	16	Snow pit dug near Elk River
K5RAC	Field - SO	TX	77,280	30	69	35	<a href="http://www.kk5na.com/Feb2002/fybo2002.html">www.kk5na.com/Feb2002/fybo2002.html</a>
N3AO	Field - SO	PA	27,360	30	45	19	Tent/trees in "Back 40"
KW4JS	Field - SO	TN	17,952	31	33	17	???
W2AGN	Field - SO	NJ	28,800	35	45	20	Backyard
K5OI	Home - SO	NM	128	35	4	4	Freezing on the patio
N4MAP	Field - SO	GA	2,856	36	21	17	Inside / outside
NQ4RP	Field - MO	GA	7,776	40	27	12	Lake Laner, GA
KØCO/M	Field - SO	CO	216	40	3	3	Driving down I-70 to see grandkids
JRØBAQ	Home - SO	JA	18	50	3	3	Home station
AB8DF	Home - SO	MI	1,260	54	21	15	Home station
N7VE	Field - SO	AZ	5,152	60	23	14	Hill near home
KB1CKS	Home - SO	ME	720	60	24	15	Cellar
VE3NXB	Home - SO	ON	1,120	61	20	14	Home station
N9RY	Home - SO	IL	1,440	62	24	15	Cool corner of basement
KI8AF	Home - SO	MI	720	62	18	10	Unheated basement
VE6AAN	Home - SO	AB	224	63	14	8	Home
NK6A	Home - SO	CA	980	67	35	14	Home station
K4FB	Field - MM	FL	9,408	70	49	24	Mary Holland Park, Bartow
K7RE	Home - SO	AZ	5,805	70	135	43	Home station in DXpedition mode
K9IUA	Home - SO	IA	980	70	49	20	Home station
AA7EQ	Home - SO	AZ	777	70	37	21	Home station (too much rain!)
NØBN	Home - SO	CO	480	70	20	12	Log cabin w/ warm fireplace :-)
K8CV	Home - MO	MI	630	72	35	18	Home station
WB7AEI	Home - SO	WA	228	74	19	12	Home station
NQ7X	Home - SO	AZ	208	75	16	11	Home station
WB6BWZ	Home - SO	GA	4	75	2	2	The shack
NA5N							—CLASSIFIED—

## RESULTS BY CATEGORY

### FIELD OPS:

Callsign	Category	QTH	Score	Low Temp	QSO Pts	SPCs	Location
NA5N				—CLASSIFIED—			
K8UO	Field - MM	MI	127,280	27	74	43	Metro Beach, Lake St. Clair
K4FB	Field - MM	FL	9,408	70	49	24	Mary Holland Park, Bartow
WQØRP	Field - MO	MN	255,360	18	140	38	Parking lot
N1QS	Field - MO	VT	133,632	5	87	32	Western slope of Mt. Mansfield
W8PIG	Field - MO	IN	86,400	27	72	30	Mounds State Rec Area
K7TQ	Field - MO	ID	43,520	29	34	16	Snow pit dug near Elk River
K8JV	Field - MO	MI	16,720	28	38	22	Local park
NQ4RP	Field - MO	GA	7,776	40	27	12	Lake Laner, GA
NØUR	Field - SO	MN	536,448	15	254	44	Parked in the middle of Eagle Lake
N9NE	Field - SO	WI	400,416	8	194	43	Abandoned industrial land
AA5B	Field - SO	NM	335,232	17	194	36	Sandia Mountains, east of Albuquerque
N3XRV	Field - SO	PA	144,720	28	67	27	Woods behind house
WD7Y	Field - SO	NV	88,704	19	77	24	In the "van tent"
K5RAC	Field - SO	TX	77,280	30	69	35	<a href="http://www.kk5na.com/Feb2002/fybo2002.html">www.kk5na.com/Feb2002/fybo2002.html</a>
WD7Z	Field - SO	NM	75,600	28	70	27	Cibola Nat'l Forest (nr Albuquerque)
N7CEE	Field - SO	AZ	62,016	9	34	19	Kendrick Park, north of Flagstaff
KIØII	Field - SO	CO	61,440	18	32	20	"Back 40"
NX9Z	Field - SO	WI	60,000	16	50	25	???
KG5N	Field - SO	CO	53,856	18	51	22	Field near Las Brisas Observatory
W1SA	Field - SO	VT	50,688	14	44	24	<a href="http://www.wcvt.com/~alank/fybo1.jpg">www.wcvt.com/~alank/fybo1.jpg</a>
W2AGN	Field - SO	NJ	28,800	35	45	20	Backyard
N3AO	Field - SO	PA	27,360	30	45	19	Tent/trees in "Back 40"
N8KV	Field - SO	MI	25,200	20	35	18	Ice fishing shelter
NØHJ	Field - SO	CO	23,040	17	30	16	Mt. Herman, near Monument, CO
KW4JS	Field - SO	TN	17,952	31	33	17	???
NØTU	Field - SO	CO	15,552	17	27	12	Mt. Herman, CO, 9064 ft. ASL
N7VE	Field - SO	AZ	5,152	60	23	14	Hill near home
AB7TT	Field - SO	AZ	3,600	28	10	9	Snow slope at 9,000 ft.
N4MAP	Field - SO	GA	2,856	36	21	17	Inside / outside
W1PID	Field - SO	NH	720	20	4	4	???
KØCO/M	Field - SO	CO	216	40	3	3	Driving down I-70 to see grandkids

### HOME OPS:

Callsign	Category	QTH	Score	Low Temp	QSO Pts	SPCs	Location
K8CV	Home - MO	MI	630	72	35	18	Home station
K7RE	Home - SO	AZ	5,805	70	135	43	Home station in DXpedition mode
N9RY	Home - SO	IL	1,440	62	24	15	Cool corner of basement
AB8DF	Home - SO	MI	1,260	54	21	15	Home station
VE3NXB	Home - SO	ON	1,120	61	20	14	Home station
NK6A	Home - SO	CA	980	67	35	14	Home station
K9IUA	Home - SO	IA	980	70	49	20	Home station
AA7EQ	Home - SO	AZ	777	70	37	21	Home station (too much rain!)
KB1CKS	Home - SO	ME	720	60	24	15	Cellar
KI8AF	Home - SO	MI	720	62	18	10	Unheated basement
NØBN	Home - SO	CO	480	70	20	12	Log cabin w/ warm fireplace :-)
WB7AEI	Home - SO	WA	228	74	19	12	Home station
VE6AAN	Home - SO	AB	224	63	14	8	Home
NQ7X	Home - SO	AZ	208	75	16	11	Home station
K5OI	Home - SO	NM	128	35	4	4	Freezing on the patio
JRØBAQ	Home - SO	JA	18	50	3	3	Home station
WB6BWZ	Home - SO	GA	4	75	2	2	The shack

# QRP Contests

Randy Foltz—K7TQ

rfoltz@turbonet.com

In this version of QRP Contests, you will find the results from the Winter Fireside SSB Sprint and our really big one, the Spring QSO Party. There are also announcements for the next few contests, specifically the PSK-31 Sprint and the other really big one, the Fall QSO Party. Let me take a few lines to give you some Fall QSO Party history. Back in 1998, and before, the contest was held on the third weekend in October. That is the same weekend as Pacificon. As QRP activity at Pacificon has grown, so has the conflict with the Fall QSO Party. In 1999, there were 5 weekends in October, so contest chairman, AB7TT, moved the party to that open weekend. All was fine and nearly everyone was happy. In 2000 when there weren't five weekends in October, so I moved it back to the 3rd weekend and just accepted the conflict with Pacificon, but many western QRPers, including me, weren't happy. In 2001, I decided to avoid the conflict with Pacificon. A seemingly plausible solution would be to move it to the fourth weekend of October. Nope that is CQWW DX phone weekend with activity on 40 meters extending down below 7.040 MHz. I chose the last weekend in September, which looked good to me. As you may remember, that was the CQWW RTTY contest with activity again extending down below 7.040. For 2002, I've moved it back to the third weekend in October.

So many contests, so many hamfests, so little time.

As a reminder, a contest submission to QRP ARCI consists of a summary sheet and a copy of your logs. The High Claimed Scores reporting form is a satisfactory substitute for a summary sheet. So are the summary sheets printed by most contest logging programs. You do still need to send me a copy of your logs, and without them you won't be eligible for any certificates or further claim to fame. I use contest submissions as a gauge of the popularity of a contest. Unpopular contests don't survive.

After each contest you can use the High Claimed Scores form at <http://personal.palouse.net/rfoltz/arci/form.htm> to send me your contest summary. Use either regular mail or e-mail to send me your logs. All the QRP ARCI contests as well as

*Mark Your Calendars:*

<i>2002 End-of-Summer PSK Sprint September 8, 2002</i>	<i>2002 Fall QSO Party October 19-20, 2002</i>
--	--

other contest information are listed at <http://personal.palouse.net/rfoltz/arci/arcist.htm>.

Ok, here is what you folks have done lately...

## Winter Fireside Sprint 2002

The 2002 Winter Fireside SSB Sprint was held on February 10th. Thirty-three stations sent in reports, down from last year's over fifty reports. On the plus side, there were two stations, W6ZH and KG4CHX, who did the sprint with less than two watts PEP. Two other brave souls, W3TS and W6SU, ran only 500 milliwatts PEP! You've got to admire those guy's determination!

Winter Fireside SSB Sprint Top Three:	
VX6ZZ	22,307
K5ZTY	16,093
N9NE	12,096

We also had a QRO station from Australia, VK2CZ, join in the fun for 45 minutes. I'm always pleased when QRO stations answer our CQ QRP TEST calls. As you reported last year, the best bands for QRP SSB were 15 and 10. Let's hope that the solar flux for next year's event will support those bands.

## Soapbox

**AL7GQ**—All stations worked were on 15 Meters with S-7 to S-9+ signals. **JRØBAQ**—Thanks to Ian KA7SOL, the only station I worked in the contest. Several stations could be heard on 15 and 10 but were very weak. Hope to see you all on next QRP contest. **K1EV**—Thank goodness I could tune the inverted vee on the upper bands. Tri-bander will be up for the next one. **K3DCS**—Watched Olympics with a little "Fireside" SSB work. **K5ZTY**—I don't do much phone contesting but this one is one of my favorites.

Plenty of activity tonight and lots of member numbers. Kudos to the guys that did this with the x10 power level. **K8KFJ**—SSB was super fun. Wish I had more OP time for it. **K9IUA**—Conditions seemed bad this year, nowhere close to last year's. Operated for only two hours before I just gave up. Sorry about that. Nice to hear people's voices. **KA7SOL**—My first QRP SSB Sprint! 15 meters was best band, but QRN made it tough copy. Can't wait for CW Sprint! **KC1FB**—Great fun! Unfortunately I had a sore throat and was hoarse. Couldn't talk for long stretches, so worked a few short spurts. The California stations were strong here in CT. **KG4CHX**—Good DX to South America and Asia. **KIØII**—Conditions seemed to be in and out. Always fun to hear voices! **N9NE**—Worked two VK, two AK, a KH6, Canadian Provinces, BC, straight east through Quebec, but no contacts with neighbors IL, or MI. **NA3V**—Intended to hand out a couple of contacts, but wound up staying for 2 3/4 hours. It was fun to hear the voices of a lot of hams I have worked CW. **NK6A**—Working stations running 1W or less is always exciting and unbelievable. Had two in the log. Worked Maui, Hawaii, (KH6HE) twice off the back of the beam. **VA7DER**—This is the first time I have heard more than a handful of stations on a QRP SSB Sprint. Sure is a lot easier on CW. **VE6AAN**—First ever QRP SSB contest. Was told I had a familiar call. (Gee, I don't get on the air all that often! Must be the Internet). **VK2CZ**—had to leave for work at 0745am local time Monday (2045 UTC Sunday), great conditions, sorry to those I had to cut short. **VX5ZX**—Quite poor conditions but I enjoyed myself. This was the last time I could use the VX prefix in a contest. **W3TS**—80 meter frequency is very busy in the east. 40 meter frequency overrun with super strong SWBC stations. Maybe the SSB Sprint could be run 2 hours earlier. **W6ZH**—SSB with 1.9 watts is hard



2002 WINTER FIRESIDE SSB SPRINT

QTH	Call	Score	Pts	SPC	Power	Bands	Time	Rig	Antenna
AB	VE6AAN	840	30	4	LT10		1	TR-5	40 m dipole, vert
BC	VA7DER	9632	86	16	LT10		4	FT817	TH3 @ 20'
CA	W6ZH	71640	199	36	LT2	80,40,20,15,10	4	K2	Vert, 2 el 40 m yagi, KT34XZ
	NK6A	49896	217	33	LT10	15,10	3.5	K2	C4 @ 40'
	W6SU	10080	56	12	LT500		2	K2	Beam, vert, dipole
CO	KIØII	30625	175	25	LT10	20,15,10	2	Omni VI	Carolina windom
	AL7GQ	770	22	5	LT10	15	0.75	SG2020	G5RV
CT	K1EV	18032	112	23	LT10	80,40,20,15,10	4	K2	Inv vee @ 32'
	KC1FB	5964	71	12	LT10	20,15,10	1	FT7, QRP+	Butternut butterfly 2 el beam
GA	K4BAI	14231	107	19	LT10	20,15,10	1.5	FT1000MP	TH6DXX
	K4GT	1421	29	7	LT10	15,10		K2	C3S @40'
	WB6BWZ	35	5	1	LT10	20	1.3	FT817	End fed inv-L @ 40'
HI	KH6HE	4977	79	9	LT10	15,10	2	HTX-100, FT301	3 el triband yagi
IA	K9IUA	16464	112	21	LT10	20,15,10	2	Argosy	55' dipole @ 20'
IL	W9HL	14616	116	18	LT10	20,15,10	4	K2	R7000
JA	JRØBAQ	35	5	1	LT10		0.5	TS440V	DJ2UT beam @ 50'
KY	KF4OTG	882	21	6	LT10	20,15,10	2.25	K2	TA33M
NC	KG4CHX	29000	116	25	LT2	40,20,15,10	4	K2	Sommers log-yagi 807
NY	WB7OCV	2296	41	8	LT10	20,15,10	4	SG2020	4BTV
OH	NG8S	3654	58	9	LT10	40,20,15,10	3.5	K2	G5RV
	AB8FJ	1120	32	5	LT10	15	2	Argo II	Random wire
PA	W3TS	35910	114	21	LT500	80,40,20,15,10	2	OMNI 6+	Inv vee, yagi @ 52'
	NA3V	25032	149	24	LT10	80,40,20,15,10	2.75	IC706PROI	130' doublet
	K3DCS	1568	32	7	LT10	20,15,10	3.5	FT817	Carolina Windom & dipole
	WBØIWG	14	2	1	LT10	10	2	FT77S	Dipole
SK	VX6ZX	223076	514	62	LT10	20,15,10	4	IC736	C31XR, EF240, 80/160 vert
TN	KW4JS	4823	53	13	LT10	40,20,15,10	3	K2	G5RV, Vert
TX	K5ZTY	160930	418	55	LT10	20,15,10	4	K2	C4S
VK	VK2CZ	464	58	8	GT10	10	0.75	TS940S	7 el yagi
WA	KA7SOL	4389	57	11	LT10	20,15,10	3	IC 706MKIIG	R7, wire
WI	N9NE	120960	360	48	LT10	40,20,15,10	4	K2	Triband beam, CFZ, rot dipole
	W9WIS	44702	206	31	LT10	40,20,15,10	4	Omni	GAP Titan
WV	K8KFJ	2912	52	8	LT10	80,40,20	1.5	IC706MKII	Vert+80m dipole

work! **W9HL**—Not as many stations heard as last year. Still had a good time, really had to work to dig the stations out. **W9WIS**—Had a great time again this year but had to work harder. Conditions not as good as last year. Thanks to everyone that I made contact with especially KH6HE, in Hawaii! **WB6BWZ**—Started late in the Sprint. K5ZTY was the only station heard calling “CQ QRP Sprint” on 10 meters - 40 meters. Need to configure equipment so I can call “CQ” with the digital voice keyer.

2002 Spring QSO Party

The 2002 Spring QSO Party was a tremendous improvement over last year, with nearly 110 folks submitting a report. Conditions were also improved over last year, with a solar flux of 220 compared to last year at 140. We didn't quite get all the benefits of the solar flux because the plan-

etary A index was 15, making conditions a bit rough on 80 meters and 40 meters with a little impact thrown in on 20 meters just to keep us humble. I always find participants comments on conditions interesting. This year they ran from “great conditions” through “marginal” to “poor.” Depends on your expectations and outlook, I suppose.

Usually I limit folks soapbox comments to two lines, but this one is too good to shorten. Bill Kelsey, N8ET, wrote, “Murphy always arrives for the QRP Tests, and this was no exception. TR quit talking to the Omni 6, and it delayed me a couple hours getting started. I finally started working the contest while troubleshooting the data comm problem. Finally found a broken cable, and then found the data interface card in the Omni 6 was not functional. Plugged in a data unit from an Icom and got going mid afternoon. After many

hours of noticing that the 40 meter beam did not seem to have much directivity, I noticed that someone had switched the dipole and beam feed lines. At least the rotor got a good work out! The contest seemed slow most of the time. It was a struggle to stay in front of the rig the whole contest period. Rates were way down. I did manage to make some 160 meter QSOs. Next year I will have the RX antennas connected, and that should help even more!”

That certainly is a sad story, Bill, but readers take a look at Bill's score. 1,116,540 points for 6th place overall. Most of us would love to have such bad luck! A tip of the contest manager's hat to you Bill for your perseverance and operating skill. Think what he could do without all those handicaps.

In the soapbox comments are several that indicate first participation in QRP

**SPRING QSO PARTY 2002**

QTH	Call	Score	Pts	SPC	Power	Bands	Time	Rig	Antenna
AL	W4DEC	842240	1280	94	LT5	160,80,40,20,15,10	18.5	K2	A4S @ 70'
	KS4L	139944	408	49	LT5	80,40,20,15,10	7	K2	Horiz loop
	K4NVJ	80066	301	38	LT5	40,20	7.5	K1	136' dipole
	AB9CA	37380	178	30	LT5	40,20,15,10	10.5	IC707	40 m dipole
AZ	K7RE	2045940	1677	122	LT1	40,20,15,10	24	K2	Tribander, rot dipole @ 40'
	NQ7X	265050	465	57	LT1	40,20,15,10	8	TS850S	3 el tribander
	AA7EQ	45108	179	36	LT5	40,20,15,10	5	K2	GAP Titan, inv vee
BC	VE7SL	294224	592	71	LT5	40,20,15,10	5.9		
CA	W6ZH	290745	585	71	LT5	160,80,40,20,15,10	8.5	K2	Triband yagi, 2 el 40 m, vert
	NK6A	231924	502	66	LT5	40,20,15,10	7	K2	C4
	W3SE	130340	532	35	LT5	15	9	FT817	A3 @ 30'
	WA7SPY	102396	318	46	LT5	40,20,15,10	15.5	K2	Carolina windom 40
	AD6GI	67032	266	36	LT5	20,15,10	6	K2	Dipoles
	KB9LGJ	47320	260	26	LT5	15	13	K1	Dipole
	AD6JY	46592	208	32	LT5	40,20,15,10	7	K2	HF9V
	CO	KØFRP	1396500	1330	105	LT1	160,80,40,20,15,10	21	TS850
KIØII		408240	567	72	LT1	80,40,20,15,10	10	TT Omni VI	2 windoms @ 30'
NØTK		381108	698	78	LT5	40,20,15,10	14	K1, HTX100	Attic dipoles
WFØK		20300	116	25	LT5		2	Emtech 80/20	65' long wire in attic
DE	KBØLUR	5159	67	11	LT5		1.5	K1	Dipole
	WB3GCK	45320	206	22	LT1	40,15	7.5	SW-40, MS-15	24' HB Vert
FL	N4BP	2672640	1856	144	LT1	160,80,40,20,15,10	23	FT1000MP	TH7, 402BA, dipoles
	KG4FSN	57057	247	33	LT5	20,15	9	NW20, MS15	Dipole
	AF4LD	14364	108	19	LT5	40	7	MFJ-9040	Dipole
GA	K4BAI	363832	712	73	LT5	80,40,20,15,10	6.75	FT1000MP	TH6DXX, dipole, inv vee
	KE2WB	350056	658	76	LT5	80,40,20,15,10	13	HW9	131' dipole @ 40'
	AF4PP	120400	344	50	LT5	40,20,15,10	7	K1, K2, Sierra	Crossed doublets @ 50'
	K4GZZ	35126	193	26	LT5	20,15,10	11	FT920	TH3
HP	HP1AC	107702	314	49	LT5	20,15,10		IC706	TA33jr
ID	K7TQ	171710	446	55	LT5	40,20,15,10		K2	C4S @ 50'
IL	N9WW	29673	157	27	LT5	80,40,20,15	7	K1, FT301SD	Multi-band dipole @ 35'
	N9RY	13776	123	16	LT5	20	2.5	TS570D	Attic inv vee
	N9EXY	11025	105	15	LT5	40,15	7		
	W9CUN	7826	86	13	LT5	40	5	TT Delta 580	40 m horiz loop @ 8'
	WB9MII	450	15	3	LT1	20	0.75	FT817	Indoor G8PG vert
IN	K9PX	304934	947	46	LT5	40	15	K2	80 m loop
	N9AVG	71400	255	40	LT5	40,20,15	7	K1	44' dipole
	K9UT	26838	142	27	LT5	20,15	3	K2	Sloper
KS	WBØSMZ	756	27	4	LT5	20	2	NorCal 20	Butternut vert
KY	K4AVX	51373	179	41	LT5	40,20,15,10	2	FT817	40 m dipole
	N4LH	4872	58	12	LT5	40	1.5	HW8	80 m delta loop
MA	NB1B	328055	721	65	LT5		8	K2	C3 @ 60'
	AA1MR	197880	388	51	LT1	40,20,15	17	K1	80 m dipole
	K1GDH	47880	180	38	LT5	80,40,20,15,10	6	HW9	G5RV, TA33jr
	W1XH	43183	199	31	LT5	80,40,20,15,10	6	FT817	70' random wire
ME	AA1MY	702706	1033	96	LT5	40,20,15,10	17	IC706	2 - 88' zepps @60'
	KØZK	498456	828	86	LT5	40,20,15,10	18.8	K2	20 dipole in attic
MI	K8CV	255136	544	67	LT5	160,80,40,20,15,10			
	AB8DF	145530	378	55	LT5	80,40,20,15,10	5	K2	105' dipole @ 40'
	KI8AF	82992	304	39	LT5	40,20,15	8	K1	Zepp
	K8DD	72324	287	36	LT5	80,40,20,15	2	K2	G5RV @ 70'
	N8TDH	12495	119	15	LT5	40	6	MFJ-9040	Dipole
	WA2OCG	6370	65	14	LT5	40,20,15	3	FT817	Maldol whips
MN	NØUR	1224000	1200	102	LT1	160,80,40,20,15,10	18	K2	Yagi, wire
	NØHRL	6048	72	12	LT5	40,20	4	K1	Attic dipole

QTH	Call	Score	Pts	SPC	Power	Bands	Time	Rig	Antenna
MO	WAØOTV	2698	142	19	GT5	15	4	TS530S	Indoor dipole
MS	K5HQV	182329	427	61	LT5	80,40,20,15,10	10	FT1000MP	140' dipole, ham stick
MT	AC7GM	10080	90	16	LT5	40,20,15	3.25	DX77	G5RV
NC	N4HAY	110700	369	30	LT1	20	8.75	K2	5 el 20 m yagi @ 73'
	WB2QAP	12971	109	17	LT5	40	3	K1	Isotron 40 m
NH	W1PID	4690	67	10	LT5	80,40,20,15	3	FT817	OCF dipole
NJ	N2CQ	1068235	1327	115	LT5	80,40,20,15,10	16	TS850	TA33jr, doublet
	W2AGN	303260	514	59	LT1	80,40,20,15,10	17	QRP++, Argo II	300' horiz loop, KT34, dipole
	K2JT	229200	382	60	LT1	160,80,40,20,15,10	5	Sierra	Doublet
	W2JEK	105609	321	47	LT5	160,80,40,20,15,10	5.5	FT840	Dipole, gnd plane, endfed dipole
	K2PQ	90902	302	43	LT5	40,20,15,10	7	TS850	Dipole, random wire
NM	W5TTE	4158	54	11	LT5	20,15	4.5	FT101F	End fed wire
NY	W2QYA	63360	192	33	LT1	40,20,15	14	HW8	Inv vee
	K2UD	6930	77	9	LT1	40		49er, SMK1, 2N2/40	End fed 1/2 wave
OH	N8ET	1165540	1154	101	LT1	160,80,40,20,15,10		Omni VI	
	WB8RTJ	54026	227	34	LT5	40,20,15,10	3.5	FT920	C4SXL, dipoles
	KB8X	29260	190	22	LT5	40	6.75	OHR 100	40 m dipole @ 35'
OK	K5AAR	222950	490	65	LT5	80,40,20,15	14	HB Xcvrs	TA33, dipole
	KA5J	1134	27	6	LT5	20,15	0.3	IC735	Inv vee @ 25'
ON	VE3IGJ	26642	173	22	LT5	20	10	K2	Inv vee
PA	N3AO	438060	745	84	LT5	160,80,40,20,15,10	11		
	K7SZ	241150	530	65	LT5	80,40,20,15,10	12.5	K2	TH7DX @ 52', 40 m EDZ
	K3WW	209286	453	66	LT5	160,80,40,20,15,10	7	K2	40 2CD, 1/4 wave vert, C3
	W3TS	138600	264	35	LT250	160,80,40,20,15,10	3	HB superhet	160 m tee, inv vee, 2 el yagi
	W3ZMN	135905	353	55	LT5	80,40,20,15,10	12	K2	Dipole, vert
	K3HX	127946	481	38	LT5	20		TS870	20 dipole @ 30'
	N3IUT	81312	264	44	LT5	80,40,20,15,10	16	K2	C4 @ 60'
	WB3AAL	47300	215	22	LT1	20	6.5	K2	Beam
	K3NVI	21735	135	23	LT5	80,20,20,15	4	TS130V	Long wire, vert, mini-quad
RI	K8ZFJ	58240	208	28	LT1	80,40,20,15,10	12	Argonaut 515	G5RV
SK	VE5RC	8624	77	16	LT5		0.6	K2	2 el tribander
TN	NY4A	1168160	1490	112	LT5	160,80,40,20,15,10	21.5		
	K4BX	71120	254	40	LT5		7	K2	Dipole
	KW4JS	35931	177	29	LT5	40,20,15,10	7.5	K2	Vert, double Zepp
	N4QZU	2646	42	9	LT5	20	0.5	DSW20	G5RV
TX	W5USJ	277662	601	66	LT5	40,20,15,10	16		
	W5TA	29141	181	23	LT5	20	1.75	Red Hot 20	HB 5/8 vert
	KZ5J	17780	127	20	LT5	20	6	K1	Dipole @ 7'
UT	KD7AEE	685860	1065	92	LT5	80,40,20,15,10	9.5		
	WA7LNW	571242	938	87	LT5	40,20,15,10		K2	272' wire loop
	W7TU	162127	437	53	LT5	20,15,10			
VA	K4JM	138138	506	39	LT5	80,40,20,15,10			135' inv L
	K3SS	43680	208	30	LT5	80,40,20,15,10	5	FT757GX	Inv vee @ 35'
	N4ROA	9555	105	13	LT5	80,40	1.5	K2	450' loop
	K4UK	5208	62	12	LT5	40,20	0.66	K2	160 m dipole
VT	W1SA	11648	104	16	LT5	40,20	1.5	K1	TH6DXX, 40 m half square
WA	K7NTW	470645	791	85	LT5	40,20,15,10	20	TT Omni VI+	40 m vert, 2 el quad
WI	N9NE	726138	1017	102	LT5	160,80,40,20,15,10	14.5	K2	Tribander
	NK9G	44352	192	33	LT5	40,20,15,10	10	TS940S	PRO 57, 40 m rot dipole
	WA9PWP	5124	61	12	LT5	40,20,15	1.5	K1	20' wire in tree
WV	WA8WV	155700	519	30	LT1	40	8.3	FT1000MP MKV	EF240 @ 40'
	K8MIA	134568	356	54	LT5	80,40,20,15			
	K8KFJ	12446	127	14	LT5	80	3		

ARCI contests. We welcome you, and hope that you found the contest experience enjoyable. I hope to hear from you again in the next one.

A look at the top ten once again shows that running 1 watt to get the 10x multiplier pays off. Five of the top ten used 1 watt. There were the usual favorites, N4BP, K7RE, KØFRP, and NØUR, as well as a few new ones to the top ten box.

Take a look at the team scores. Once again, the Aluminum Kings ruled the roost. That five member team placed 1st, 2nd, 3rd, 4th, and 6th. You have to combine the other top 18 finishers to equal the score of the Kings. If you didn't work several of these guys, you just weren't trying. FB Kings!

One final note. Take a look at the entries for Georgia and you will find K4BAI. If you take a look at the list of competitors in the World Radiosport Team Championships, you will also find K4BAI, John Laney, as one of the teams representing the USA. Selection as a team member indicates that an individual is one the very best in contesting—World Class, for sure. I'm very impressed and pleased that John participates in our QRP ARCI contests. The WRTC 2002 is July 13th and 14th during the IARU HF World Championship, which may be over by the time this issue gets out. Nevertheless, good luck in Finland, and thanks for participating in our contests, John. Next time you run across K4BAI in our contests take a bit of time to say hello.

The next QRP ARCI contest of this size is the Fall QSO Party in October. See you there.

### Soapbox

**K9PX**—No other contests this weekend. Nice scheduling, Randy. **K8KFJ**—Unfortunately other commitments kept my operating time to a minimum. Was able to grab a few Qs on Saturday evening on 3.5, so just did the single band thing this time. **K3HX**—Surprising amount of activity on 20 meters. Highpoint was being called by LZ2RS. Best QRP DX in years. Looking forward to next sprint and FD. **N4HAY**—Excellent test of new antenna! **N4ROA**—Unable to operate much, but sure did enjoy what time I had. **WAØOTV**—15 meters was good this year. It was nice hearing a lot of old friends on the band. **W5TTE**—Been a long time since I got into one of

these contests. Almost forgot how much fun they are. Didn't have much time on this one, but I'll be back at it with dedication in the Fall. **K4GZZ**—Great contest. FISTS guys were in there too! Bands were not that great, but it really didn't matter. **N9RY**—Still amazed at what 5 watts and simple antenna provides. **K5HQV**—Conditions were marginal here on Sunday.

### 2002 Spring QSO Party

#### Top Ten:

1	N4BP	2,672,640
2	K7RE	2,045,940
3	KØFRP	1,396,500
4	NØUR	1,224,000
5	NY4A	1,168,160
6	N8ET	1,165,540
7	N2CQ	1,068,235
8	W4DEC	842,240
9	N9NE	726,138
10	AA1MY	702,706

#### Category Winners

Less than 250 mW	W3TS	138,600
15 m band only	W3SE	130,340
20 m band only	K3HX	127,946
40 m band only	K9PX	304,934
80 m band only	K8KFJ	12,446
High bands	W7TU	162,127
Low bands	N4ROA	9,555

#### Teams

Aluminum Kings — N4BP, K7RE, KØFRP, N8ET, NØUR — 8,504,620

NJQRPeaNUTS — W2AGN, N2CQ, N2CX, AA1MY, K2PQ — 2,165,103

Team Utah — WA7LNW, W8EQA, KD7AEE, W7WIK — 1,257,102

Eastern Pennsylvania QRP Club — N3AO, WB3GCK, WB3AAL, KB3TS, N3RBN — 530,680

15 meters was the workhorse. Just never heard too much activity on 10 meters either day. Worked everyone I could hear. **WA9PWP**—Just testing the K1 with internal batteries and there were stations that needed to be worked! **AF4LD**—New member and first QRP ARCI contest. **K4UK**—Got in only 40 minutes. Was watching the Masters Golf Tournament. **K9UT**—My first contest and really enjoyed it! **NK9G**—Used new "HamPilot" software with Palm IIIe & Graffiti soft-

ware. Software great! Graffiti no way again! Keyboard next time. **K2JT**—Would be nice if we had a little more elbow room on 20 meters. **K18AF**—Lots of band noise (QRN), but enjoyed the contest and more contacts than I thought I would. Thanks to all. **W2JEK**—Great contest. **N4LH**—Just dropped in to revive the good old HW8 given me by my late buddy, W4ELO. The party was lots of fun! **KB9LGJ**—Thanks for the hard work Randy! **K4NVJ**—FUN. More time would have been more fun! **KØZK**—I do a jazz radio show on Saturday nights so I miss Saturday night operating. **W1SA**—Enjoyed by first QRP event with my new K1! **KS4L**—Great fun! Thanks for a FB contest! **K3NVI**—Poor band conditions! **W3TS**—Only had a little time to operate. Tried to work as many as possible, but 40 meters seemed "dead" at the end. **WB9MII**—Time was limited but enjoyed the contest immensely. Milliwatt can be done from inside a condo. **NB1B**—Just finished the K2 yesterday—planned to get on for a while, wound up staying longer than expected. Couldn't believe working the JAs with one call the KH2 even more surprising. **WB9AAL**—Managed to work 6.5 hours between painting and having a migraine headache. I still had a ball. Thanks to everyone for all the QSOs. **VE5RC**—Just finished my basic K2 rig so thought I'd try it out on and off during the contest. Worked great and I'm looking forward to putting in a greater effort next go around. **WFØK**—Could not work more than 2 hrs, but enjoyed the fun. There were a lot of patient ops who did not object to repeating numbers. I'll plan on working all the ARCI contests. **N9AVG**—Had a blast despite the poor propagation and local thunderstorms. A battery powered K1 and a dipole provided 7 hours of fun for me this weekend. Bring on the Hoot Owl Sprint! **NQ7X**—Tough conditions, signals would drop out in the middle of an exchange, but fun anyway. Thanks to ARCI and all who hung in there. **WB8RTJ**—First time in the contest and had a great time. What better to do on a rainy weekend. 72s to all. **W2AGN**—Conditions pretty poor, lots of QRN. Started off with QRP++, but needed receiver in K2. **K8ZFJ**—Great fun, even with a dusty old Argo 515 and rusty CW ears! **AB8DF**—Weather was too nice for an all out effort. Got on Saturday after all the chores were done and Sunday for a

couple of hours. 20 meters was disappointing. **NOHRL**—Thunderstorms cut me short Sat night. Nice weather Sunday—was hard to stay at the radio. **W6ZH**—No KL7 or KH6 this time. Did get call from Cam, **HPIAC**. **W4DEC**—Enjoyed contest but bands seemed to come and go. Stations were spread out a little more than in former contests and for the most part contestants were polite. **AA1MY**—Bands really punky but worked good DX. Very spotty propagation. Plagued by very old/troublesome laptop w/dead clock and many lock-ups. Lost 80 meter Qs. **AF4PP**—Great contest...thank you for taking the time to promote, score, manage, etc. It is much appreciated. **KØFRP**—Conditions were not the best but did my best pulling through the weak ones. 10 meters was not good here in CO, 13 Qs was all I could get. **AB9CA**—Had a great time. Stayed longer than I had planned. Only my second contest, and my code is not so good yet, so thanks to all the other ops for their patience. **KIØII**—Planned on working high bands only but was not making many contacts so jumped into the 40 meter fray for some needed contacts and multipliers. Always a fun event. **K7NTW**—QRP ops come through with flair in spite of rotten band conditions. East coast spotty, but still a blast of a contest. **N4BP**—Doubled last

Spring's score. One watt is definitely the way to go. Thanks to all who moved from band to band for me. Surprised to be able to work ten states on 80 meters. **N9WW**—High background noise levels made for tough conditions. Thanks to all ops who hung in there to work me. **KBØLUR**—First ARCI Sprint for me—fun despite poor conditions. **WB3GCK**—I operated while on a camping trip to Lum's Pond State Park in Delaware. Great fun handing out DE as a new multiplier for many stations. **KZ5J**—This was my first QRP ARCI contest and I had a blast. The highlight of the test was working NØRC and his mighty 250 mW. **K4AVX**—Thanks to KØFRP, who looked up my QRP ARCI # as my first QSO. I was portable and forgot to take it with me! From his score, it looks like I didn't take up too much of his time!! **K4BX**—Will play more next year and hopefully conditions will be better. Never heard a sig on 10 meters. **NK6A**—here seems to be more CA activity this year than previous years. Either that or band conditions were so poor I barely got out of my own backyard. **AD6GI**—Limited time, but had a lot of fun. Found S+P to work best on this one for me. Thanks to the many fine operators for their excellent ears. **K2PQ**—Other than Spartan sprint or FOX hunt first serious attempt at a contest.

Was antenna poor with coax fed 40 meter dipole. Put up random wire on Sunday. I'll be ready for the fall. **K8MIA**—Had a great time with some bad band conditions at times. Thanks guys. Looking forward to my membership number. **N9NE**—I did work stations on all HF bands and worked several DX stations. The best was TL8DV in Central Africa on 10 meter CW (Dave gave me a 579!). **K7RE**—Had more QSOs than ever before, but didn't match the total with SPCs that I needed. Still, it was great fun, if not a little slow on Saturday due to Friday's solar flare. **N2CQ**—Not the best conditions in memory. Good activity on Sat night late but tough sledding on Sunday. **NO5W**—15 meters was the money band here with 20 meters having very high QRN. 10 meters was open from time to time but not many stations trying it. Maybe next time conditions will be better. **W5USJ**—Completely surrounded by thunderstorms Sat and Sun. Too much noise to do much good on 40 meters. Missed the best opening on 10 meters. One of my better scores for this event. **AD6JY**—Usually I just play in the contests and hand out a few points, but I had more QSOs than usual in this one. **W5TA**—First time I've participated in this contest. Lots of fun! I'll be back. ●●

## Contest Announcements

### 2002 End of Summer PSK-31 Sprint

#### Date/Time:

September 8, 2002; 2000Z to 2400Z - 20 meter band & PSK-31 only

#### Exchange:

Members — State/Province/Country, Name, ARCI Number  
Non-members — State/Province/Country, Name, Power Out

#### QSO Points:

Member = 5 points; Non-member, Different Continent = 4 points; Non-member, Same Continent = 2 points

#### Multipliers:

SPC (State/Province/ Country) total.

#### Power Multiplier:

0 - 250 mW = x15  
250 mW - 1 W = x10  
1 W - 5 W = x7  
Over 5 W = x1

#### Suggested Frequency:

20 meters: 14070.15 kHz

#### Score:

Points x SPCs x Power Multiplier.

Entry includes a copy of logs and summary sheet. Include legible name, call, address, and ARCI number, if any. Entry must be received within 30 days of contest date. Highest power used will determine the power multiplier. Only one signal on the air at a time.

The final decision on all matters concerning the contest rests with the contest manager. Entries are welcome via e-mail to [rfoltz@turbonet.com](mailto:rfoltz@turbonet.com) or by mail to

Randy Foltz  
809 Leith St.  
Moscow, ID 83843

After the contest send your Claimed Score by visiting <http://personal.palouse.net/rfoltz/arc/arcisum.htm>. You must still submit your logs by either e-mail or regular mail if you use the High Claimed Score form. Check the web page for 7 days after the contest to see what others have said and claimed as their scores.

### 2002 Fall QSO Party

#### Date/Time:

October 19, 2002; 1200Z through Oct. 20, 2400Z. You may work a maximum of 24 hours of the 36 hour period. CW only.

#### Exchange:

Members — RST, State/Province/Country, ARCI Number  
Non-members — RST, State/Province/

Country, Power Out

**QSO Points:**

Member = 5 points; Non-member, Different Continent = 4 points; Non-member, Same Continent = 2 points

**Multipliers:**

SPC (State/Province/ Country) total for all bands. The same station may be worked on more than one band for QSO points and SPC credit.

**Power Multiplier:**

0 - 250 mW = x15  
250 mW - 1 W = x10  
1 W - 5 W = x7  
Over 5 W = x1

**Suggested Frequencies:**

160 meters	1810 kHz
80 meters	3560 kHz
40 meters	7040 kHz
20 meters	14060 kHz
15 meters	21060 kHz

10 meters 28060 kHz

**Teams:**

You may enter as a team of either 2 to 5 members per team or unlimited number of operators as long as a maximum of 5 transmitters on the air at a time. You compete individually as well as on the team. Teams need not be in the same location. Team captain must send list of members to Contest Manager before contest.

**Score:**

Points (total for all bands) x SPCs (total for all bands) x Power Multiplier.

Entry may be All-band, Single-, High-, or Low-Band. Entry includes a copy of logs and summary sheet. Include legible name, call, address, and ARCI number, if any. Entry must be received within 30 days of contest date. Highest power used will

determine the power multiplier. Only one signal on the air at a time.

The final decision on all matters concerning the contest rests with the contest manager. Entries are welcome via e-mail to [rfoltz@turbonet.com](mailto:rfoltz@turbonet.com) or by mail to

Randy Foltz  
809 Leith St.  
Moscow, ID 83843

After the contest send your Claimed Score by visiting <http://personal.palouse.net/rfoltz/arci/arcisum.htm>. You must still submit your logs by either e-mail or regular mail if you use the High Claimed Score form. Check the web page for 7 days after the contest to see what others have said and claimed as their scores.

Contest results are published in *QRP Quarterly* ●●

## Kazo Kontesting

Michael Sealfon—WA2OCG

[wa2ocg@aol.com](mailto:wa2ocg@aol.com)

How to turn a springtime business trip to Kalamazoo, Michigan into a very pleasant contesting experience? Pack a Yaesu FT-817 and all the necessary operating accoutrements into a simple Jansport backpack, suffer the numerous security indignities at two major airports, and walk like the Hunchback of Notre Dame weighted down with luggage, briefcase, etc.

My usual station-in-a-pack consists of the FT-817 with Radio Shack 1600 mAH batteries, a Radio Shack 3Amp power supply (yes, complete with noise—I was able to place the unit behind a brass planter to reduce the hash), MFJ 945E mobile antenna tuner, MFJ Bencher key, a pair of Radio Shack Optimus Nova 64 foldable headphones, four Maldol antennas for 10-40 meters, and a camera tripod modified to electronically mimic a vertical antenna counterpoise. The tripod idea was “borrowed” from the Alpha-Delta Outback design. All three tripod legs are connected by 14 gauge copper wire and fed into the BNC base-plate which holds the Maldol antennas. All this gear weighs approximately 25 pounds, but is easily carried in a backpack.

The Kalamazoo QTH was located on the nineteenth floor of a twenty-story high-rise apartment complex, and the open patio faced east to south. I had to angle the antenna outward at a forty-five degree angle to clear the concrete, but this seemed to work well (see photo).

Conditions for the ARCI Spring Contest seemed excellent, and to my great surprise I was able to make fourteen QSOs in FL, AL, ME, NJ, TX, CO, and other closer states on 40, 20, and 15 meters with relatively good signal reports. Two of the strongest signals were from N4BP, and N2CQ. When not on the air, the rig made for some nice European and Asian shortwave listening. Even with a marginal antenna, being nineteen stories high certainly makes a difference!



The portable antenna used for WA2OCG's ARCI Spring QSO Party operation in Kalamazoo (“Kazo”).

I'm looking forward to Field Day 2002 and using the same station on battery power. Hopefully, I can make it to the roof of the high-rise, and have an unobstructed field of view. The QSO totals should be dramatically improved. Hope you all can have as much fun as I did! ●●

## IMHO—Homebrew is Alive and Well

Jerry Hall—WØPWE

<http://www.qsl.net/w0pwe>

In late April an article appeared in the *Scientific American* entitled “R.I.P. for D.I.Y. Science Tinkerers Continue To Take It On The Chin.” The article addressed the lack of enthusiasm for “do it yourself” (D.I.Y.) projects that is apparently evident in all areas of scientific endeavor. Ham radio was mentioned several times in the article, and one ham was even quoted as saying “The art of home-brewing one’s own electronic equipment is pretty much a lost one.” I was a little shocked when I read the article because it didn’t seem to describe ham radio as I know it.

I returned to the hobby after an extended absence early in the year 2000, and what drew me back was all the homebrew activity in the QRP community. It seems that if the *Scientific American* article is correct, then the QRP world is in remarkable contrast to the trend noted in other fields of amateur science. I am not familiar with trends in amateur astronomy, robotics, and some of the other amateur science fields mentioned in the article, but I most certainly believe that if hams are feeling D.I.Y. is dead they haven’t discovered the world of QRP. As QRP enthusiasts, we are fortunate to have clubs that promote homebrew construction and make it affordable for everyone. We have many kit makers catering to our needs, and we have lots of support from fellow builders and gurus. In this article, I have tried to document the positive homebrew climate we live in and point out why it doesn’t look to me like homebrew construction is dead. This is based only on my experience in a time frame of roughly 1970 until the present; your perspective may be different.

### Better Ingredients

I believe the homebrewer today has more parts and better parts to build with than ever before. Those parts are also more readily available than they used to be. The explosion of wireless technology worldwide has driven chip makers to develop and market devices we could only dream about in years past. Many of these devices have trickled down to the ham homebrew market and have a price/perfor-



**Kids like homebrew too. Here, Ed Hare, W1RF1, is instructing the author's son during the building event at the Iowa QRP Convention 2001.**

mance ratio that makes them very attractive. The proliferation of microcontrollers and microprocessors in our homes, offices, and cars has also given us some pretty cool homebrew ingredients as well. We can thank cell phones for the NE602/SA612 chips so common in our QRP rigs, and cheap microprocessor crystals allow us to have high performance crystal filters for just a few dollars. DDS and DSP chips keep getting better all the time, and some of our projects use that kind of technology.

### Parts Are Readily Available

When I was a kid trying to build gear in the early 70s, I always had trouble finding parts. My dad was a ham and a homebrewer from way back so I had some parts on hand, but it seemed like every project had plenty of parts that I just couldn't find. In a nearby city there was a store that sold parts to radio and TV repair shops, and when I got desperate enough I would go there and try to get a part. It was a dingy, dirty, and disorganized place in the bad part of town. The people who worked there were generally unfriendly, and if you didn't have an exact part number you were usually out of luck. Worst of all, their parts were all behind the counter, so there was

no browsing. Some large suppliers would do mail order back then, but you more or less had to masquerade as a legitimate business in order for them to sell to you. They also generally had large minimum order requirements, and service was pretty slow.

Today we have many excellent parts sources available to us. Digikey and Mouser are the ones you most often hear about in the ham community, and they are both excellent. They have large catalogs full of high quality parts, and they will sell to anyone. For the most part, they have reasonable minimum order and service charges, they don't mind selling you one or two of an item, your order usually ships the day you place it, and you can even have it on your doorstep tomorrow if you want to pay for overnight shipping. You can also go to their web pages and check availability (which is seldom a problem) and you can get data sheets and product information there as well. If you need additional information on a part, a quick call to their office will usually have a data sheet on it's way to you in minutes via e-mail or FAX. In addition to the big commercial sources, there are also many smaller companies and individuals that offer great deals on some of the more hard to find parts. The NOR-

CAL parts kits are another excellent source for homebrewers, and have been offered in assortments of toroids, capacitors, and resistors, and for a minimal cash outlay you can have a pretty impressive parts inventory.

Homebrewers typically like to scrounge parts from discarded equipment, and in the old days, radios and televisions were about all we had to pick from. Those certainly had some good parts in them, and as a kid I appreciated the supply of 365 pF variable capacitors available at curbside on any given garbage night. Today's electronic discard however, contains a wider range of devices, and things like cordless phones and VCRs can have some pretty useful parts in them.

### Better Tools

If you search the Internet a little you will find all kinds of nifty freeware that can make your homebrewing efforts more productive and enjoyable. Sound card software is available that will help you characterize filters. If you want to make your own circuit boards, there are several very nice CAD programs available. There are tons of programs you can download that will walk you through the design of output filters, matching networks, antennas, etc., and there are even SPICE freeware programs available on the Internet. Simulating a circuit using SPICE is not as difficult as it may sound, and using these programs and simulation offers the homebrewer a great way to learn about circuits and try out ideas before warming up the soldering iron. If you want to work with microcontrollers, most chip makers provide assemblers and development tools on their web sites for free, and programming circuits are simple to build and well published.

Setting up a test bench doesn't have to be an expensive endeavor either. Some very nice kits are available for things like LCR meters and frequency counters, and good oscilloscopes and signal generators can be found at hamfests and on e-bay for a reasonable price. The ubiquitous "antenna analyzer" is also a very handy thing to have on the bench, and a search of the QRP literature will turn up a number of construction projects for simple test equipment. Many of these projects make nice starter projects for the beginning homebrewer.

### Plenty of Great Circuits to Build

The *Scientific American* article notes the passing of some publications that catered to the tinkerer like *Popular Electronics* and *Byte Magazine*. There was a time when these publications were very popular and some of the ham magazines seemed to contain more construction articles. I randomly pulled the December, 1978, *73 Magazine* from my collection and noticed that it had twenty-five construction/technical articles, ranging from code practice oscillators to an X-band transceiver. Granted, we don't see that kind of material all in one place on a monthly basis anymore. Still, there are plenty of good projects to be built, and new ones are being developed all the time. The monthly ham magazines and publications like the *ARRL Handbook* are still excellent sources. In the QRP world we have periodicals put out by several clubs, either in paper form or on the Internet, and many individuals are publishing projects and technical info on their own web sites. The web sites of chip makers are also a source for project information, and some even have application notes that include board layouts and micro-controller source code.

### Talented Elmers

We QRPers are really rich in this area. We have many talented and highly experienced folks willing to help us solve a problem or understand a circuit. In the old days, it was hard to gain access to this kind of technical expertise because you generally only had the talent pool in your local area to draw from. Now, with the Internet, your "Elmer" can live anywhere in the world, and may very well be an expert on the topic of your question. With all the newsgroups, various ham related reflectors, and QRP-L, you have easy access to some excellent help.

The *Scientific American* article mentions the technical elite, professional engineers and scientists who tinker in order to keep up to date. The article states that "...these elite have left other amateurs so far behind that it is hard to draw new people into their ranks." Again, I believe the QRP world runs counter to this statement. On QRP-L, for example, we see excellent posts by leading designers, engineers, physicists, and authors. Whether the question relates to biasing mosfets, or calculating the efficiency of some newfangled

antenna design, these people can boil it down to the essential details and present it in a manner that anyone can understand. They are indeed way out ahead of many of us, but from what I can tell, they are patient and more than willing to help those who are bringing up the rear.

There are also many great examples of "Elmering" in the QRP community; some I have witnessed and many I have not. One excellent example is the 2N2-40 group on Yahoo.com. John Wagner, N1QO, organized this group to build the 2N2-40 Manhattan style transceiver designed by Jim Kortge, K8IQY. Initially, some group parts buys were made and some people donated parts so that a partial kit of parts could be offered to the builders at a very minimal cost. The designer himself sorted hundreds of crystals and put together kits of matched crystals and various other parts for two different versions of the crystal filter. These were made available to the builders at a very reasonable cost, and when people started building they started asking questions, Jim was right in there, answering each and every one. Whether it required a sentence or a page to answer, he provided the answer quickly and in a polite and professional way. What a great opportunity for homebrew and education! You get to build a rig from scratch, and you have a direct line to the designer in the process. Where else but the QRP world does that kind of opportunity exist? And with that kind of assistance, your homebrew project is almost guaranteed to be a success. After 10 months in operation, the list is still going strong and it has 156 members. Since the beginning, over 2100 messages have gone back and forth, and the Yahoo files area contains a wealth of information in the form of schematics, parts lists, calibration procedures, waveforms, and pictures of completed rigs. Many of the people who built rigs in this group were building their first homebrew radio.

### Kits and More Kits

When I returned to the hobby in 2000, I was amazed at the quantity of kits available, the excellent quality of the offerings, and the low prices of these kits. No one will deny that the passing of Heathkit left a

*continued on page 64...*



## QRP ARCI STAFF

President

**Joe Spencer—KK5NA**  
3618 Montridge Ct.  
Arlington, TX 76016  
kk5na@quadj.com

Vice President

**Dick Pascoe—G0BPS**  
Seaview House, Crete Road East,  
Folkestone, Kent, CT18 7EG, UK  
g0bps@gqr.com

Secretary/Treasurer and  
Membership/Subscription Renewal

**Mark Milburn—KQ0I**  
117 E. Philip St.  
Des Moines, IA 50315-4114  
mark.milburn@juno.com

Membership Chairman  
**Steve Slavsky—N4EUK**  
12405 Kings Lake Dr.  
Reston, VA 20191-1611

Awards Manager

**Thom Durfee—W18W**  
3509 Collingwood Ave. SW  
Wyoming, MI 49509  
wi8w@arrl.net

Contest Manager

**Randy Foltz—K7TQ**  
809 Leith St.  
Moscow, ID 83843  
rfoltz@turbonet.com

Past Presidents

**Jim Stafford—W4QO**  
w4qo@arrl.net  
**Mike Czuhajewski—WA8MCQ**  
wa8mcq@comcast.net  
**Buck Switzer—N8CQA**  
n8cqa@att.net

## BOARD OF DIRECTORS

**Tom Dooley—K4TJD**  
4942 Dock Ct.  
Norcross, GA 30092  
tdooley@attbi.com

**Ken Evans—W4DU**  
848 Valbrook Ct.  
Lilburn, GA 30247  
w4du@bellsouth.net

**George (Danny) Gingell**  
3052 Fairland Rd.  
Silver Spring, MD 20904-7117  
k3tks@abs.net

**Hank Kohl—K8DD**  
2130 Harrington Rd.  
Attica, MI 48412-9312  
k8dd@arrl.net

**Jim Larsen—AL7FS**  
3445 Spinnaker Dr.  
Anchorage, AK 99516-3424  
al7fs@arrl.net



QRP ARCI is now taking membership applications and renewals via credit card—*online*—using the **PayPal** system. **In fact, we prefer it**—this is true for all applicants—worldwide! Simply go to the club website: <http://www.qrparci.org/us2signup.html> and follow the instructions. Be sure to select the appropriate button for the area of the world you reside in (per box below).

PayPal replaces all previous methods of payments for non-US hams, except that you may always send your payment directly to Mark Milburn, our Treasurer. **Funds must be drawn on a U.S. bank and be in U.S. dollars.** Make checks out to: QRP ARCI.

If mailing your application (if renewing, it helps to send in the mailing label from your *QQ*), send it to:

**QRP ARCI—Mark Milburn, KQ0I**  
117 E. Philip St.  
Des Moines, IA 50315-4114

Need an Information Pack? Send e-mail to [k3tks@abs.net](mailto:k3tks@abs.net), or send an SASE to:

**Danny Gingell, K3TKS**  
3052 Fairland Rd.  
Silver Spring, MD 20904-7117

TIPS: 1. Use the Online Member Lookup feature to keep track of your membership status—check: <http://www.qrparci.org/lookup.html>  
2. Is your data on file now correct? Use the online form to send info to our database manager: <http://www.qrparci.org/>

US—\$15 • Canada—\$18 • Non-US/VE—US\$20 per year

## New Member or Renewal Form

CALL \_\_\_\_\_ QRP ARCI# (OR "NEW" IF NEW MEMBER) \_\_\_\_\_

FULL NAME \_\_\_\_\_

MAILING ADDRESS \_\_\_\_\_

CITY \_\_\_\_\_ STATE/COUNTRY \_\_\_\_\_

POSTAL CODE (ZIP+4 FOR USA) \_\_\_\_\_

PREVIOUS CALLSIGN(S) (IF ANY SINCE JOINING) \_\_\_\_\_

(THE FOLLOWING IS OPTIONAL AND IS NOT RELEASED TO OTHERS)

E-MAIL ADDRESS \_\_\_\_\_

COMMENTS \_\_\_\_\_

## **Become a Famous Author! Write a Review for QRP Quarterly**

Have you just purchased a new gadget, rig or kit that you would like to tell the QRP world about? Then write a review and send it to the *QRP Quarterly*! Reviews are handled by our Special Features Editor, Larry East—W1HUE (see page 3 for address). We have no strict guidelines for reviews, but we do ask that you include the manufacturer's basic technical specs and any results of technical tests that you have performed. If you are not sure about some aspects of the device that you are reviewing, don't guess; ask the manufacturer for clarification. (We reserve the right to also contact the manufacturer for additional details or clarification.) Please try to be as objective as possible; tell about the good as well the bad features. Larry prefers to receive articles in machine-readable form, as ASCII text files on PC format floppy disks or as e-mail attachments.

If you want to send word processor files, Larry can handle MS Word 6/95/97/2000, Word Perfect 5/6 and Rich Text Format (RTF) formats. Please don't do any fancy formatting or embed graphics within WP files! Figures (drawings and photographs) can be supplied as "hard copy" (good quality B&W or color prints for photographs) or as digitized images (check with the Editor for acceptable formats). If you want your disks, drawings, etc. returned, please enclose an SASE with sufficient postage. ●●

major void, but as QRPers we are fortunate to have many people working hard to fill that void. QRP clubs like NORCAL and NJQRP have done a wonderful job of producing kits and making them available to us, and we owe them a huge thank you. They have not only given us an incentive to build, but they also push us to expand our skills and try new techniques, like Manhattan construction, Islander construction, and surface mount technology. They really do a top-notch job, and their kits reflect that. The boards and components are professional quality and they provide excellent documentation and assembly instructions. This takes a tremendous amount of work, and it is all done entirely by volunteers who are extremely dedicated and want to share the joy of homebrew with as many of us as possible.

We are also fortunate to have so many companies producing kits that cater to our needs. Many of these companies have

grown from roots similar to those of Elecraft. A talented designer built gear for his own use and soon found others wanting similar equipment. A few articles were published, a few kits produced, and before long a viable company is born. These companies probably aren't as big as Heathkit, and they don't market products with as much mass appeal as Heathkit did, but they do provide the QRP'er with lots of interesting things to build. Whether it is a little PIC keyer or a full-featured transceiver like the K2, there most surely is something to match everyone's skill level and operating interests. To get a feel for how many kits are actually available, I searched the links from a couple of QRP club web pages and found sixteen companies offering kits. Between those companies and the various QRP clubs, I counted about 160 kits that were directly related to QRP or homebrewing. In my quick search, I didn't find all the companies or clubs who make

kits, and I didn't count every kit and all the variations of the different kits. The number, while very rough, does indicate that QRP operators like to build kits and that their wishes are not going unanswered.

### Conclusion

I feel fortunate that I discovered what was going on in the QRP world before I learned that homebrew had been pronounced dead. Otherwise, I might have believed it and perhaps I would have stayed away from this hobby that has provided me so much enjoyment since my return. I believe that homebrew will always be alive. The parts and where we get them may change, building techniques may change, and our information sources may change, but I don't think people will ever fail to recognize the joy that comes from building your own gear.

—de Jerry, WØPWE

●●

## The Last Word

The *QRP Quarterly* invites readers to submit original technical and feature articles as a service to fellow QRP enthusiasts. Although the *QRP Quarterly* cannot pay for submissions accepted for publication, it will acknowledge, with thanks, authorship of all published articles.

Due to space limitations, articles should be concise. Where appropriate, they should be illustrated with publishable photos and/or drawings.

Full articles should go to any of the volunteer editors for review. Information for columns should be sent directly to the column editor. See the page 3 for addresses. Submit technical and feature articles with a printed copy and a copy on disk, if possible. ASCII text is preferred. Photos and drawings should be camera-ready or in TIFF or JPEG format. Other formats can be used with prior approval.

Technical and feature articles should be original and not be under consideration by any other publication at the time of sub-

mission to *QRP Quarterly* or while the *QRP Quarterly* is reviewing the article. If you contemplate simultaneous submission to another publication, please explain the situation in a cover letter.

Material for possible use in *QRP Quarterly* should be sent to only one of the editorial volunteers, not to several at the same time. The *QRP Quarterly* editors and columnists will transmit the submission to others on the staff if it better fits another category.

Accepting advertisements for publication in *QRP Quarterly* does not constitute endorsement of either the product or the advertiser.

Material cannot be returned unless accompanied by sufficient postage.

The act of mailing a manuscript constitutes the author's certification of the originality of the material.

Opinions express are those of the authors and do not necessarily represent those of the QRP ARCI, it's officers,

### Board of Directors, staff or advertisers.

The *QRP Quarterly* will occasionally consider reprinting articles previously published elsewhere if the information is especially useful to members of QRP ARCI. If your article has been published, include the name of the publication and the issue it appeared in. In all such cases, the *QRP Quarterly* will obtain permission to reprint from both the author and the original publication, and will acknowledge the source of the material.

The *QRP Quarterly* will occasionally print information first appearing on QRP-L after obtaining the author's permission and ascertaining that the information is not scheduled to appear in another publication.

Copyright of materials published in *QRP Quarterly* remains with the author. Although the author retains the right to reuse the material, the *QRP Quarterly* requests that reprints of of the material in other publications acknowledge the first publication in *QRP Quarterly*. ●●

**W4RT**  
Electronics™

Perfect Accessory Quartet for the FT-817  
**ONE-TOUCH TUNE™** • **ONE-PLUG POWER™**  
**ONE-BOARD FILTER™** • **LDG Z-II Autotuner**

*Tuning the YAESU FT-817 has Never Been Easier!*

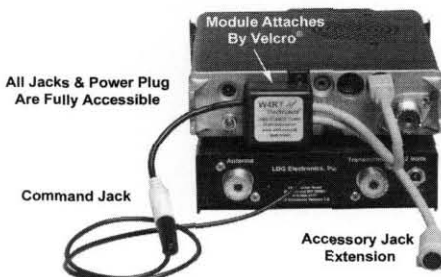

All Jacks & Power Plug Are Fully Accessible

Command Jack

Accessory Jack Extension

**NEW!**

**ONE-BOARD FILTER™** SSB Filter

AT LAST THE FT-817 CAN HAVE

**BOTH CW & SSB FILTERS!**

- Collins Mechanical Filters
- 500-Hz CW & 2.3-kHz SSB
- Only \$299.95 INSTALLED

PLUG-IN FILTERS

500-Hz CW: \$124.95  
2.3-kHz SSB: \$139.95

**ONE-PLUG POWER™**

Rapid Charging Now!

External  
Charger Jack

\$59.95

Replaces Existing Battery  
Door and Tray

Molex Connector  
to the FT-817

- 1650 mAh NiMH Batteries
- Over-Current & Over-Temp Fused
- Use FT-817 Internal Charger
- Use NiMH Fast External Charger

W4RT Electronics & LDG Electronics Have Collaborated to Provide You  
**The Ultimate FT-817 Tuning Solution!**

- Tune by Just Pressing the Tune Button on the LDG Electronics Z-11 QRP Autotuner!
- Requires Only ONE-TOUCH TUNE™ and the Z-11 Compatibility Kit. Simple Installation!

**LDG Z-11  
AUTOTUNER**

**\$239.95 Package**  
Z-11 & One-Touch Tune

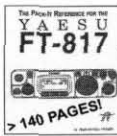

\$9.95

The Most Comprehensive  
FT-817 Reference Guide Available!  
The Famous Yellow Book by VE3AYR

**\*\*\* Z-11 Owners \*\*\***  
Make Your LDG Z-11  
ONE-TOUCH TUNE™ Compatible  
Only \$9.95 (incl. S/H in USA)

W4RT Electronics™ Offers the LDG Z-11 Tuner  
Fully Assembled, Modified and Tested to be  
ONE-TOUCH TUNE™ Compatible!

**ORDER ON-LINE or BY FAX**

• **www.W4RT.com** •

W4RT Electronics • fax: 256.880.3866

In the UK or Europe, Contact Waters & Stanton PLC: www.wsplc.com  
Unless otherwise stated, shipping & handling charges apply. Prices may change without notice.  
W4RT Electronics is a Division of Optical E.T.C., Inc. W4RT Electronics, ONE-TOUCH TUNE, ONE-PLUG POWER, & ONE-BOARD FILTER  
are trademarks of Optical E.T.C., Inc. Copyright © 1999 by Optical E.T.C., Inc. All rights reserved.

Ball Dog Lambic Key \$24<sup>95</sup>

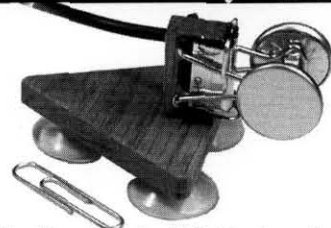

*Rivals the feel of full size keys!*

1 oz, 2" W x 2.5" L x 1.5" H  
Adjustable spacing and tension  
3' pre-wired cable with 1/8" plug  
**Money Back guarantee!**  
**Visa/Master Card Accepted**  
S & H only \$2.50

Toll Free 1-877-227-9139 AmateurRadioProducts.com

— **FAR CIRCUITS** —

Printed Circuit Board Design and  
fabrication for Amateur Radio and  
hobby projects

18N640 Field Ct.  
Dundee, Illinois 60118  
(847)836-9148 Voice/Fax

Catalog: [www.cl.ais.net/farcir/](http://www.cl.ais.net/farcir/)  
Email: [farcir@ais.net](mailto:farcir@ais.net)

**GigaParts**®  
Online Superstore!

[www.gigaparts.com](http://www.gigaparts.com)

Secure On-Line Ordering

Free UPS Ground  
on orders over \$200



Own the hottest little  
radio for the coolest  
price around.

**FT-817**  
**\$CALL\***

**YAESU**  
Choice of the World's top DX'ers™

Call TOLL FREE (866) 535-4442

4925 University Drive, Suite 140  
Huntsville, Alabama 35816

Tel: (256) 535-4442

Email: [hamsales@gigaparts.com](mailto:hamsales@gigaparts.com)

Open Mon-Sat 10-7 & Sun 1-4

\*Price and availability subject to change



1. On the move

2. Pick a band

3. Getting ready

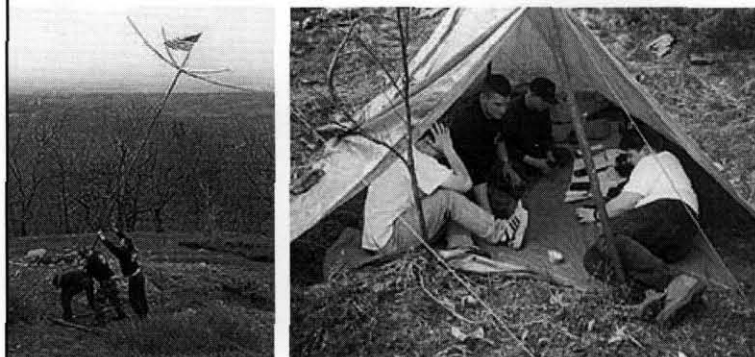

4. Up it goes

5. On the air ... less than 30 minutes!

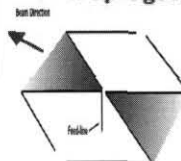

MINIATURIZED CONTROLLED FIELD ANTENNAS

Traffic Technology

[www.hexbeam.com](http://www.hexbeam.com)

421 Jones Hill Road, Ashby, MA 01431-1801

978-386-7900 Phone/Fax 1-888-599-BEAM Toll Free USA

Our K1 transceiver just became a 4-bander! With its small size, low current drain, and 5-watt+ output, the dual-band K1 was already a great rig for home or field operation. But we've taken the K1 to a new level with our KFL1-4 option, which covers 40, 30, 20, and your choice of 17 or 15 meters—all on a single plug-in module. Adding the internal auto-tuner (KAT1), internal AA battery pack (KBT1), and wide-range tilt-stand (KTS1) makes the K1 a truly "trail-friendly" radio. For more details on the K1, as well as on the K2 all-band, 15-watt SSB/CW transceiver, please visit our web site.

"My son built a K1, and was very impressed. As the ex-chief engineer of Heath, may I offer my congratulations for a kit job well done – and I should know!" – Mike Elliott, W8KRR

"This is really a kit? In my 20+ years now of playing with electronics and building kits I have NEVER seen a kit that fits together like this. It's magic." – Randy Rathbun, NV0U

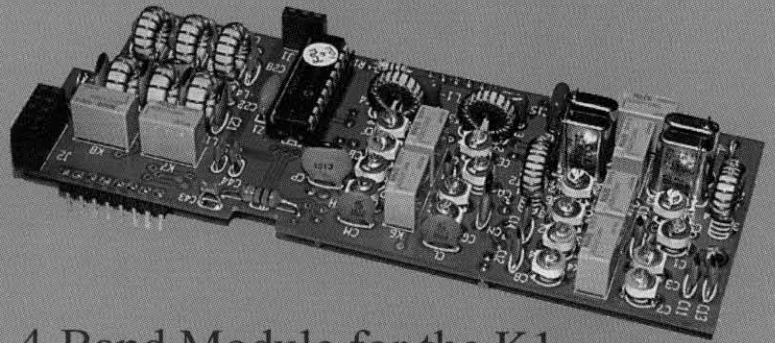

4-Band Module for the K1



[www.elecraft.com](http://www.elecraft.com)

 **ELECRAFT**

P.O. Box 69  
Aptos, CA 95001-0069

Phone: (831) 662-8345  
sales@elecraft.com

