

# QRP Quarterly

Journal of the QRP Amateur Radio Club International

Volume 43 Number 4

October 2002

\$4.95



The Tuna Twin Too  
... a companion receiver  
for the Tuna Tin transmitter

- An Interview with “Dr. Megacycle,” Jim Duffey, KK6MC
- A HF In-line Return Loss and Power Meter
- The ‘QuickieLab’ — A BASIC Stamp Design Platform
- The Electroluminescent Receiver
- Contest Results — Milliwatt Field Day, Summer HB Sprint



QRP ARCI is a non-profit organization dedicated to increasing worldwide enjoyment of radio operation, experimentation and the formation and promotion of QRP clubs throughout the world.



# The QRP-ARCI Toy Store



The **official** QRP-ARCI Coffee Mug. Used by the top QRP Fox hunters, contesters and casual operators found near the normal QRP Frequencies. Kelly Green on White and the Logo is on both sides. Coffee, tea or milk not included.



The QRP-ARCI patches are fully stitched, black on white. 3-9/16" wide x 2-1/2" high oval. And they can either be ironed on, or sewn on the finest evening wear!



Trouble reading those resistors? Plastic magnifiers for kit builders in a carrying case. Magnifiers are \$1.00 each.

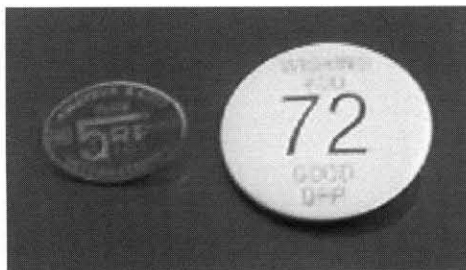

The blue and brass metal pins have a tie-tac pin and clasp on the back.

The White '72' pins say "WISHING YOU 72 GOOD QRP"



Midnight Blue mugs are still available.

All Prices PostPaid!

Patches \$5    Coffee Mugs \$8    Blue Pins \$7

2002 Dayton FDIM Proceedings...	\$17
2001 Dayton FDIM Proceedings...	\$17
2000 Dayton FDIM Proceedings...	\$16
1999 Dayton FDIM Proceedings...	\$16
1998 Dayton FDIM Proceedings...	\$16
1997 Dayton FDIM Proceedings...	\$16
1996 Dayton FDIM Proceedings...	\$16
Any 4 or more FDIM Proceedings...	\$13 each

**Antennas & Feedlines for QRP** by L.B. Cebik... \$16

**The North Georgia QRP Club Compendium, Vol. 1...** \$16

No shipping & handling on pins & patches when ordered with a coffee mug!

### QRP-ARCI Hats

Denim Blue Tan Charcoal Tan/Blue  
Tan/Green Green

Hats are \$15 each postpaid

Orders to:

QRP-ARCI Toy Store

1640 Henry

Port Huron, MI 48060

Checks made out to: QRP-ARCI

or PayPal to k8dd@arrl.net



A Division of Milestone Technologies, Inc.

**"Everything For The Morse Enthusiast"**

- ✓ Keys
- ✓ Paddles
- ✓ Bugs
- ✓ Keyers
- ✓ Software
- ✓ Kits
- ✓ Books
- ✓ Tools

**www.MorseX.com**



A Division of Milestone Technologies, Inc.

*Free Catalog*

**303-752-3382**  
2460 S. Moline Way  
Aurora, CO 80014

## Kanga US

### New Products Available at Dayton:

- Hands Electronics RTX-109 - All Band SSB/CW Transceiver--6 or 20W version.
- R2Pro by KK7B - High performance DC RX module.
- DK9SQ Folded Vertical - All bands 80 - 10 including WARC. No Traps!
- Torment Electronics VFO Module in a Clock Oscillator Module.

### Coming soon from Hands Electronics:

- Monoband xcvr for PSK31/MFSK/RTTY for any band  
3.5 - 50 Mhz

### Still available:

- Spectrum Analyzer and Tracking Generator by W7ZOI and K7TAU
- R1, miniR2, T2, and LM2 by KK7B
- DK9SQ Mast, Loop, and Dipole
- Kits from Kanga Products, Hands Electronics, and Sunlight Energy Systems



**Kanga US**  
3521 Spring Lake Dr.  
Findlay, OH 45840 419-423-4604  
[www.bright.net/~kanga/kanga/kanga@bright.net](http://www.bright.net/~kanga/kanga/kanga@bright.net)

# QRP Books

**Quality Books for the Low Power Enthusiast**

**Antennas ♦ RF Design ♦ Reference Manuals**  
**Operating ♦ Proceedings ♦ Measurement**

**21 Myers Heights Road Lansing, NY 14882**

**[www.QRPBooks.com](http://www.QRPBooks.com)**

# Table of Contents

## QRP Quarterly

Volume 43 Number 4 — October 2002



On the cover and page 27

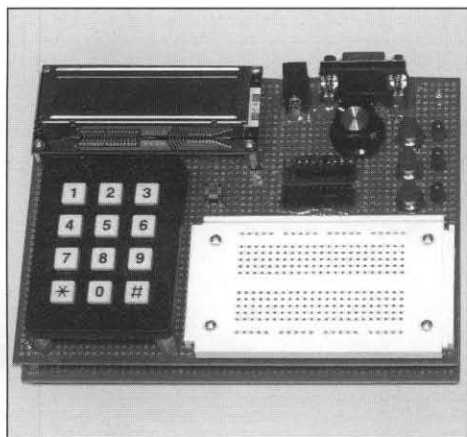

page 44



page 55

### Technical

- 8 Idea Exchange—Mike Czuhajewski—WA8MCQ  
*A Digital Voltmeter with Audible "Display"*—Joe Everhart, N2CX  
*Ignore Color Codes on IF Cans*—Paul Harden, NA5N  
*MFJ Manuals Available on the Web*—(DK3RED)  
*MFJ-259(B) Info on the Web*—(DK3RED)  
*Heathkit Schematics Online*—WA8MCQ  
*Good Info on the Elecraft Mail Reflector*—WA8MCQ  
*I/O Expander Adds Useful Functions in Small Projects*—George Heron, N2APB  
*Amplifier for 40M Milliwatt Rigs*—Jake Carter, N4UY  
*Decoupling Capacitor Rules of Thumb*—Dave Fifield, AD6A  
*Duct Tape as Insulation*—Bob Melville, K3WRV  
*AM/SSB Reception on the DSW Rigs*—Bill Mabry, N4QA  
*Another HW-8 Toroid Success Story*—AA3SJ, WA8MCQ  
*Frequency Alignment of TenTec 13xx Rigs*—Dennis Doran, WB8WTU  
*Microminiature QRP Crystals and FT-817 Filters*—WA8MCQ  
*QRP On-line*
- 17 An HF In-line Return Loss and Power Meter—Paul Kiciak—N2PK  
27 The Tuna Twin Too—Mike Boatright—KO4WX  
32 Improved AGC Performance for the Sierra Transceiver—Larry Wilson—KFØN  
34 Digital QRP Homebrewing—George Heron—N2APB  
*Digital QRP Breadboard—"Baseboard & Enclosure"*  
*Spotlight on...The PIC Weather Station Project, Part 2: Communications*
- 40 The Electroluminescent Receiver—David White—WN5Y  
44 The QuickieLab—George Heron—N2APB  
48 QRV? The Ubiquitous Cathode Ray Tube—Mike Boatright—KO4WX  
50 Test Topics and More—Joe Everhart—N2CX  
56 The Micro-80 Transceiver—Oleg V. Borodin—RV3GM

### Operating

- 33 QRP, QSOs and QSLs—The Joys of a Rookie QRPer—Rev. Fred Hembree—N4SSD  
58 QRP Contests—Randy Foltz—K7TQ  
*2002 Milliwatt Field Day*  
*2002 Summer Homebrew Sprint*

### Reviews

- 26 Review: Palm Radio Mini-Paddle and Code Cube—Richard Arnold—AF8X  
63 Review: Outbacker Joey Antenna System—David Gilson—KD3EM

### Columns and Departments

- 3 Across the Editor's Desk—Mike Goins—WB5YJX  
4 From the President—Joe Spencer—KK5NA  
4 Announcements  
*New QRP ARCI Members*  
*U-QRP Club Being Reactivated as RU-QRP*
- 43 Ramblings of a Displaced Cajun Lad in Maine—Joel Denison—KE1LA  
54 QRP Clubhouse—Mike Fletcher—KL7IXI/7

### Miscellaneous

- 5 An Interview with James "Dr. Megacycle" Duffey, KK6MC/5  
55 QRP Activities at Hamboree 2002  
56 Kentucky QRP Group  
64 New or Renewal Membership Application  
64 QRP ARCI Staff and Directors

## QRP QUARTERLY EDITORIAL STAFF

Managing Editor

**Michael Goins—WB5YJX**  
3030 Shadowbriar, #225  
Houston, TX 77082  
mgoins@usa.net

Associate Editor

**Larry East—W1HUE**  
15355 S. Rimline Dr.  
Idaho Falls, ID 83401-5917  
wlhue@arrl.net

Associate Editor

**John King—KB3WK**  
9936 Whitworth Way  
Ellicott City, MD 21042  
kb3wk@arrl.net

Associate Editor & Idea Exchange

**Mike Czuhajewski—WA8MCQ**  
7945 Citadel Dr.  
Severn, MD 21144-1566  
wa8mcq@comcast.net

Associate Editor—Contests

**Randy Foltz—K7TQ**  
809 Leith St.  
Moscow, ID 83843  
rfoltz@turbonet.com

### REGULAR COLUMNISTS

Digital QRP Homebrewing

**George Heron—N2APB**  
2419 Feather Mae Ct.  
Forest Hill, MD 21050  
n2apb@amsat.org

Milliwattling

**James L. Hale—KJ5TF**  
HCR 65 Box 261B  
Kingston, AR 72742  
sunwatt@starband.net

QRP

**Mike Boatright—K04WX**  
1013 Latham Rd.  
Decatur, GA 30033  
ko4wx@mindspring.com

Test Topics...and More

**Joe Everhart—N2CX**  
214 NJ Rd.  
Brooklawn, NJ 08030  
n2cx@voicenet.com

QRP Clubhouse

**Mike Fletcher—KL7IXI/7**  
Poulsbo, WA  
kl7ixi@attbi.com

peaux displaced cajun lad...

**Joel M. Denison, Sr—KE1LA**  
POB 542  
Strong, ME 04983-0542  
hamjoel@juno.com



## Across the Editor's Desk

Michael Goins, WB5YJX—Managing Editor

mgoins@usa.net



As hard as it is to believe, it's October already, and the holiday season is approaching. So is an increase in activity on 40 meters, so Mike Boatright's cover article, The Tuna Tin Too (receiver), should fit right into some holiday building plans. Mike spent a lot of time making it easy to build from all Radio Shack parts (and with all the changes in Radio Shack inventories, that was hard to do!) and a match for your Tuna Tin 2 (you do have a Tuna Tin 2 already sitting on a shelf, don't you?), so give it a try.

For those few who haven't built a Tuna Tin 2 (transmitter), you can contact Jay Bromley, W5JAY, at w5jay@arrl, or go to the NorCal website at <http://www.fix.net/~jparker/norcal/bttfut/bttfut.htm>.

Jay is the ARRL Arkansas Assistant Section Manager, lives in Fort Smith, Arkansas, and it's the Fort Smith QRP Group that does the kitting of the "Tuna Tin 2 Kit." They are available for only \$15 postpaid (and include a round board that will fit on a tuna can, all board-mounted parts, a crystal for 7.040, and a manual. You have to supply key jack, 3 RCA jacks,

a SPDT switch, hookup wire, and a tuna tin for the chassis. DX cost is \$20). Combined with Mike's little receiver, you can have a neat set on 40 meters quickly.

Now down to the other contents. This issue is filled with contributions from writers from all over, from reviews to state-of-the-art digital articles.

And I would be seriously remiss if I didn't take a moment to say thanks once again to all who participate in the three-month journey that is each issue of *QRP Quarterly*. Countless hours contributed by many, many volunteers make the magazine possible. Without them, there is would be no *QRP Quarterly*.

Finally, guys (and gals), remember that this is your magazine, and the staff and I count on you to share what you are working on with QRPers scattered all around the world. If you have an antenna article, a product review, or a new way of doing something old—whatever—email it to me and let's talk about how we can get your name and your article in a future issue of *QRP Quarterly*.

Bye for now, and I hope you enjoy this issue as much as we've enjoyed putting it together.

—Mike, WB5YJX



### Editor's Notes for Authors and Readers

#### A few common physical and electronic terms and abbreviations:

alternating current (AC)	hertz (Hz)	radio frequency (RF)
amperes (A)	henrys (H)	reflection coefficient (p)
ampere-hour (AH)	inches (in.)	root-mean-square (RMS)
bits per second (bps)	meters (m)	seconds (s)
decibels (dB)	miles (mi.)	siemens [mhos] (S)
direct current (DC)	miles per hour (MPH)	standing wave ratio (SWR)
farads (F)	ohms (Ω)	volts (V)
feet (ft.)	ounces (oz.)	watts (W)
grams (g)	pounds (lb.)	words per minute (WPM)

#### Power of ten prefixes:

$\times 10^3$ = kilo (k) — kHz, kW, kg...	$\times 10^{-3}$ = milli (m) — mW, mV, ms...
$\times 10^6$ = Mega (M) — MHz, Mohm...	$\times 10^{-6}$ = micro (μ) — μF, μH, μs...
$\times 10^9$ = Giga (G) — GHz, Gbps...	$\times 10^{-9}$ = pico (p) — pF, ps...
$\times 10^{12}$ = Tera (T) — THz...	$\times 10^{-12}$ = femto (f) — fW, fF...

## From the President

Joe Spencer, KK5NA—QRP ARCI President

kk5na@quadj.com



This year seems to be going by fast! The QQ is on track, the articles just keep getting better, and ham radio and QRP are still exciting to me and to the many others I talk to regularly.

QRP operation continues to grow, and is present in more and more magazine article, projects, field day sites and contests. Kits and building things seems to be the topic everywhere (especially K1s and K2s!).

George Heron and the NJ QRP club have some great kits and projects, and NorCal has not only a new short-wave

receiver coming out, but also a new 30 meter rig. This issue not only has the Tuna Tin Too receiver, but an article on the Electroluminescent receiver by David White! Speaking of George Heron, he has an article in *QST* this month on his great Badger kit. If you don't have one yet, look into it as it is a fun kit, a real treat at any event, and a handy keyer as well as an ID badge.

Oleg, RV3GM, checks in regularly and has provided some interesting MICRO-80 kits from Russia. He's in the process of starting up a QRP club there, so look for him on the Internet and in QRP-L.

Isn't this month's cover article great? Another fun project, The Tuna Tin Too (by Mike Boatright, KO4WX), and Mike Goins, QQ's editor and the staff are doing

a fantastic job on the *Quarterly*. Look for many new ideas and innovations soon.

For those who might have missed the July announcement, I want to let everyone know that Dick Pascoe, GØBPS, has agreed to serve and has been elected the QRP-ARCI Vice President. With him as VP and future President, we become even more International. We look forward to his help and continued leadership.

QRPers, keep doing what you are doing, building, operating, talking, teaching, and sharing. You are making an impact in the world of Ham radio, drawing more ops into QRP operations, and changing the way the world looks at cooperation and communication.

—Thanks, Joe KK5NA

## Announcements

### New QRP ARCI Members:

11259 N2IJF Gene Nitschke  
11260 KB2EGI Kip Burnett  
11261 K6VWE Stanford Rowe  
11262 AA3KC Stephen Biletz  
11263 W8NGO James Heath  
11264 AC7TR Steven Maclure  
11265 N5QC Stephen Nielson  
11266 WB1DFT Richard D'Auteuil  
11267 AL7V Frank Ilardi  
11268 N8UVF Matthew Hodges  
11269 M5ALU Allan Horsfield  
11270 W4OCJ Joe Dumond  
11271 K5IX Charles Hornburg  
11272 KD5AAD Michael Evans  
11273 K5UUH James Gilliland  
11274 KF8FG Michael Leech  
11275 KØJD John Seboldt  
11276 VK4LAJ Adam Jaroszuk  
11277 WD4FEO William Patterson  
11278 VE7HUN Dave McAllister  
11279 KJ4YM Mark Coleman  
11280 GØWFH Christopher Gresswell  
11281 K4OAH Garey Barrell  
11282 WB6CGO Darr Gruber  
11283 AB2II Patrick Casey  
11284 Michael Brainard  
11285 WA9NPS Robert Kallas  
11286 KCØLBT John Haoglund  
11287 KC9CBV Robert Krimm  
11288 KC8OAN Michael Whitco

11289 AI2M Dan Porter  
11290 JA9MAT Hidehiko Komachi  
11291 W8YMO Harrison Hooker  
11292 NØMQ Eugene Sailsbury  
11293 M5JSW Steve Woods  
11294 KD2DLN Charles Almind  
11295 DK3RED Ingo Meyer  
11296 Daniel Alli  
11297 WB4JRW David Rogers  
11298 N9EEZ Delano Swancutt  
11299 N1RR Charles Morrison  
11300 NG7Z Paul Beringer  
11301 Ken Franke  
11302 KG4TJW Alan Gordon  
11303 KD5DYY Leslie Eaton  
11304 KG4JNL Steve Wells  
11305 AE6IM Patrick O'Brien  
11306 W7QQ Bill Schwantes  
11307 KV6S Jim Moyer

### U-QRP Club being reactivated as the 'RU-QRP?' Club

Oleg Borodin, RV3GM, one of the few QRPers operating out of Russia at the moment, is currently in the process of reactivating the old U-QRP Club as the RU-QRP? Club.

George Gingell is now acting as the USA Representative and Treasurer. Oleg was the "Member Profile" for July 2002,

and will also be producing a club newsletter. George will handle the desktop publishing of it over here.

For those who might not know about Oleg's connection to the Micro-80 kits, he is currently shipping the kit around the world on a "donation" basis. Considering the price of continually rising cost of postage and parts, a donation of \$10.00 per kit should be considered by anyone wishing to give the Micro-80 a try.

Should you have an interest in the newsletter, a \$10.00 donation there too would not be out of line.

Funds raised with the sale of the kits and the newsletter will go in George's "PayPal" account (for the club), and will be used to purchase a K2 kit for the RV3GM/RU-QRP? Club.

Additional information about the club's development, the Micro-80 kits, or the coming newsletter can be obtained by contacting Oleg at <master72@lipetsk.ru> or George at <k3tks@u1.abs.net>, or you may be able to catch Oleg on the weekly World QRP Roundtable at 14.060 Saturdays at 1000 and 2200 UTC.

—72, Oleg Borodin, RV3GM,  
master72@lipetsk.ru  
—and George Gingell,  
k3tks@u1.abs.net

# An Interview with James "Dr. Megacycle" Duffey, KK6MC/5

Michael Goins, WB5YJX—Managing Editor

mgoins@usa.net

This month's interview is James "Dr. Megacycle" Duffey, KK6MC/5. Jim lives in Cedar Crest, New Mexico, at 6900 ft above sea level on the east slope of the Sandia Mountains, east of Albuquerque. Jim is known to many of those seriously involved in QRP radio as a regular speaker at various QRP events and as one of the more learned among us regarding antennas. —Editor

## Now the interview:

**QQ:** Tell us about you, Jim. Let's start with the non-radio stuff first.

**JD:** I was born July 14, 1950, in Brookings, South Dakota, and now live high on the east slope of the Sandia Mountains, east of Albuquerque, in Cedar Crest, New Mexico. I left Brookings High School after my Junior year, and obtained a BSc in Engineering Physics at South Dakota University, and later on, a PhD in Physics at the University of Nebraska.

My major interests are antennas, contesting, QRP, and operating through the satellites, and I like to backpack, cross-country ski, and I have a pretty serious interest in astronomy (I ground my own mirror). I also referee soccer, and at times it makes QRP-L arguments look pretty tame!

**QQ:** Jim, how long have you been operating at QRP power levels?

**JD:** Eight years. I've been active in QRP since 1994. I did operate a Heathkit Twoer at an optimistic 5 watts out in the late '60s as WNØMWN/WAØMWN, though. I was first licensed as a novice in 1965, and operated a Hallicrafters HT-40 at 75 watts input which, while not QRP, it wasn't exactly QRO either.

In 1994, I saw a notice for the QRP-L reflector on the antenna newsgroup. I eventually joined the group in the fall of 1994 just as the first Fox Hunt was beginning. I decided to join in the hunt, cranked my TS-850 down to 5 watts, and had no trouble working the fox. I was hooked on QRP, and have operated it as my primary mode ever since.

**QQ:** At what level do you do most of your operating?

**JD:** I occasionally crank up my Tuna Tin 2 at 500 mW, but mostly I run a QRP

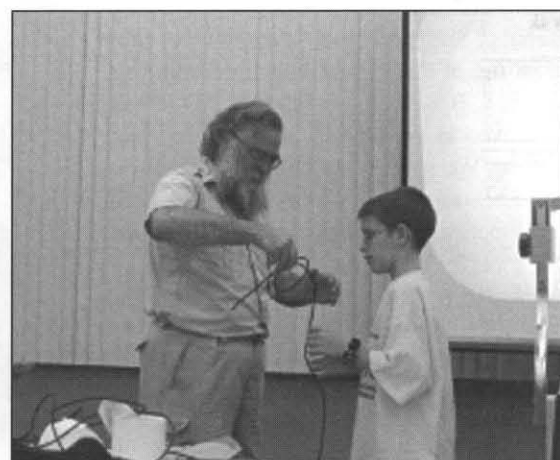

**Dr. Megacycle, Jim Duffey, KK6MC has gone from being a kid interested in ham radio (left) to helping kids understand how radio works and makes ham radio possible, as a regular speaker at QRP and other ham radio events (right).**

full gallon. I really should try QRP milliwatt one of these days.

**QQ:** Tell us about your current station. What equipment do you use, what modes do you operate, what antenna(s) do you use fixed (and/or portable), etc.

**JD:** I have a TS-850 as my main rig. It runs 5 watts effortlessly and has one of the best ham receivers ever built. I also have a OHR Classic 20/40 rig, and a K-1. On six meters, I run an ICOM-551D at a non-QRP 80 Watts. On 2 meters, I use a Kenwood TS-9130. I also have a Radio Shack HTX-100 for 10 meters, and use this combination for satellite work. I also have an SB-110A that needs repair, and a Yaesu FT-101E in the same boat. Too many projects, too little time.

I operate CW mostly. I do keep twice weekly skeds on SSB with my Dad, WAØOML, but other than those skeds and the SSB Sweepstakes, I don't operate phone much. I have dabbled with PSK31, Hellschreiber, and RTTY, but I don't get the enjoyment out of them that I do with CW. Go figure.

I have a 44 foot dipole up 30 feet, fed with 450 ohm ladder line in the center. It works great from 40 meters to 10 meters. On 80 meters and 160 meters, I tie the feeder conductors together and feed it as a vertical against a couple of elevated radials.

For portable operations, I use the K-1 or the OHR Classic. These are powered by a 7 AH 12 volt gel-cell that is charged with

a solar cell that puts out about 270 milliamperes. That combination will go all day and as much of the night as I can stay up. I use parallel dipoles erected as an inverted Vee for an antenna, supported by a 17 1/2 foot high extendable paint pole. I am fortunate in that New Mexico has lots of good sites for portable operation with high elevation and good radio horizons.

**QQ:** What was your first station? Your first QRP station?

**JD:** My first station was a Hallicrafters HT-40 transmitter and a Hammarlund HQ-110A receiver. I manually switched the antenna with a B&W coax switch and muted the receiver manually from the front panel. This was a typical, or maybe a bit better than typical, Novice station in 1965. My dad received his license shortly after I did and upgraded the transmitter to a Johnson Ranger II. Although this was (and is) a superb CW/AM transmitter, in retrospect he would have been better off buying a better receiver.

My first QRP rig was the OHR 20/40. It is a nice rig, with a solid receiver using a balanced diode mixer. It lacks a digital readout, but for most QRP uses, close enough in frequency is good enough. Lacking bells and whistles (other than a built-in keyer), time may have passed it by, but the performance of newer rigs has not. It's still a solid performer.

**QQ:** When you were first getting started in amateur radio, did you have an

“Elmer” or mentor? If so, how valuable was the experience?

**JD:** I had a variety of Elmers. My mother taught me the code when I was going for my First Class badge in Boy Scouts. She later took the Novice class with me at the local club, The Brookings Radio Research Society, WØBXO. Licensed as WNØMZI, she did not get on the air. We lived within 10 minutes of my high school, and I walked home at noon and operated 15 meters. Mom would turn the receiver on before I got home to get it warmed up (those old tube rigs drifted a bit). I would then get on the air when I got home and she would serve me a sandwich or something else I could eat in my hands while I operated. I thought everybody’s mother would do this for them, but I now realize that I was blessed.

After I upgraded to General, I still had to operate voice on AM. AM was going out, there were few people to talk to, and they were other impoverished teenagers and old timers. One day I came home from school and Mom said that a college freshman, Jim Wennblom, WAØARZ, had seen my antennas and stopped by. He was looking for someone to keep his Galaxy 300 while he was in school so he could use it to make contacts home. I could use it when he didn’t. I was in Seventh Heaven. SSB at last! Jim is now KØHW, and I connected with him at the Hamboree where I attended the Iowa QRP forum. After 30 years, I finally got the chance to thank him.

Ed Gray, WAØCPX (now WØSD), taught the code portion of my Novice class, and Dick Smith (call forgotten), taught the theory. Ed Collins, KØCXX (?) taught the theory for my General class. Jack Headley, WØKXZ, was very supportive even when I was young. He rewired our house when I was only nine and told my parents to keep the old wire for us kids to play with (it later became radials!).

**QQ:** So your interest in amateur radio really did have an influence on your choice of career paths, or was it that your career path lead you to amateur radio?

**JD:** I have always been interested in things technical, so ham radio was a natural pursuit. I am not sure that my career in physics came from ham radio, but it didn’t hurt at all. After all, nerds are nerds, and we are drawn to these activities.

**QQ:** Do you do any specialized operating, like contesting, DXing, foxhunting,



**Here is KK6MC enjoying some of the better things in life—good food, good drink and the outdoors. (The QRP rig must be nearby!)**

mobile, or portable operating? Any specialized gear you use for it?

**JD:** I contest, but not as much as I would like. I do as many of the QRP field events as I can, I do the Spartan Sprints (which are ideal contest warm up activities), and I operate Sweepstakes and the 10 meter contest. The only special equipment I use for contesting is a CMOS Super Keyer II.

I am also a casual DXer. If it is there I work it. A half dozen tries in a pileup and I call it quits. I keep telling myself that I will go for DXCC at the next solar maximum.

I was active in the first fox hunt, and I have operated them off and on since then. To me they have lost much of their informal appeal, and I don’t operate them much any more.

I do enjoy the satellites and operate the RS Mode A/K birds when I can. I started with Oscar 7 in its dying days. Mode A doesn’t require much in the way of equipment and I am surprised more QRPers don’t try it.

**QQ:** Do you belong to any radio clubs or organizations?

**JD:** Unfortunately, I am not much of a joiner. However at one time or another I have been a member of NorCal, ARCI, ARRL, MARS, AMSAT, and a couple of local clubs. Most of the local clubs have evolved into repeater organizations, and I have never been too fond of that mode, although I do use them from time to time.

**QQ:** One of the greatest things about amateur radio is that there are so many dif-

ferent areas in which to get involved.

What are your primary interests at the moment, and what areas of radio have you been involved with in the past?

**JD:** I do enjoy giving talks at various QRP forums. I’ve talked at all the major QRP forums west of the Mississippi. This gives me great pleasure, the hams are very receptive to QRP and it feels good to spread the QRP word.

I like to experiment with antennas. I have a 40 meter vertically polarized loop and a wire element Log Periodic fixed to the NE in the works. They should get put up before Sweepstakes. I also have parts from two 14AVQs in the garage and I want to make some 3/8 wave verticals from them.

I am also working on the winning VCXO design for Pacificon. I have a killer idea (watch me finish 2nd!).

I like to collect and measure audio filters. I have about 13 or 14 of them. Each has its pluses and minuses. This is one area that a collector can get involved without spending a fortune. I operate about 7 or 8 of them on a regular basis, and the performance of some of these filters is really amazing.

I also like weak signal VHF work (it has a lot in common with QRP), and I am getting a rover station ready for VHF. Here in the Southwest, there is not much activity on SSB and CW VHF, so it is quite rewarding to get on the air.

In the past I’ve been involved in satellite work and traffic handling. I still do some satellite work, but I no longer handle traffic. I used to operate a lot of SSB, but I now work CW almost exclusively.

**QQ:** Sometimes operating at low powers can be a real challenge, even for those with experience. What advice would you give someone just getting started in low power (QRP) radio?

**JD:** The first thing to do is to try it. Don’t hesitate. Almost all rigs can be turned down to the 5 watt level. I spent a lot of time thinking that QRP would be fun, but never tried it. I regret that hesitation now, as I see that I missed out of a lot of fun.

Getting the first QRP QSO is important. It gives one confidence that low power communications is possible and fun. I think 30 meters is the best band to try first. Listen and call a strong station calling CQ. There are usually loud stations calling



CQ near the FISTS frequencies, and they are eager to work people. If you can find a local QRPer, there is nothing wrong with setting up a schedule with him.

QSOs are a bit more difficult at 5 watts than at 100 watts, but they are not impossible. It just takes some patience. A support group is helpful; QRP-L serves this function on a global level. It is also likely that you can find locals to get together with to support your habit.

Remember that if you are working a typical 100 watt station, you will be about 13 dB weaker in his receiver than he is in your receiver. At S-9, you will not have many problems. At S-1 or S-2, you will.

Almost all ham radio activities call for a singular skill. Listening. Listen to the bands as often as you can. Make a commitment to listen regularly. Turn on the rigs and listen for 15 minutes every day, twice a week, or whatever. Then do it. Listen for different band conditions. Learn to know when the band is noisy. Learn to know when the band is open to where. Listen. A good set of headphones helps. A good antenna helps. You can't make contacts if you are not on the air. Get on the air.

**QQ:** Where do you see QRP/amateur radio going in the future?

**JD:** If I could predict the future I would be very rich! I see QRP growing. QRP is currently one of the fastest growing phases of the hobby. I expect that trend to continue for the foreseeable future.

It seems to me that niches of the hobby like QRP are becoming havens for hams that reject the direction that ham radio has become; slow code, repeater based, and appliance operation. These aspects of ham radio aren't bad in themselves, but the traditional ham radio activities like homebrewing and CW operations are best epitomized in QRP today. Many hams, both new and old, want to participate in these traditional ham activities, so these activities will continue to grow.

I always get questions from non-QRPer's at hamfests. It is a attractive portion of the hobby to many. I also get comments from non-hams who are impressed that I can build a radio in an Altoid Tin, power it with a 9 volt battery, and work across the country with it. These activities present our hobby in a much more positive light than does a trip into a shack with commercial radios all lined up.

Our QRP field activities are probably more representative of what emergency communications would look like in this country than many of the traditional field day setups do. Most of us operate from batteries on a daily basis, so the truest test of emergency communications, "Can you use it in a real emergency?" is answered everyday. And there are probably thousands of these stations throughout the country! I see these field contests growing. I also suspect that someone will do something to coordinate all of this emergency communications potential. It is often ignored in the traditional emergency tests.

The homebrew side of QRP is becoming quite sophisticated and elegant, yet paradoxically increasingly simple at the same time. Look at the offerings of SWL (Small Wonder Labs)—the Rock-Mite and DSW. These are innovative steps in radio design, and I think that we will see more of this in the future. The electronic keyer gets reinvented every few years by QRPer's, and we will have more goodies to see from other designers soon.

I see the commercial manufacturers realizing that QRP is an untapped potential and trying to exploit it. As a result of this, I hope that we will see some innovative

high performance commercial QRP rigs. We have begun to see some of this already, but no commercial company has quite come up with the perfect QRP rig, at least for me. But when Yaesu can sell 20,000+ 817s in a couple of years, it must make Kenwood, Icom, Ten-Tec, and Elecraft sit up and take notice of the potential QRP market.

The Internet has made a big impact on QRP. It has provided an avenue of communication that is largely responsible for the explosive growth of QRP in the 1990s, and there are literally hundreds of QRP web sites that answer almost question that a QRPer can ask. I see this trend continuing, with the offerings becoming more sophisticated. The monthly internet publications of several QRP groups are outstanding and available to all, and I expect to see more of these offerings.

QRP journals are the leading purveyor of homebrew information to the Ham Radio community, and I see this continuing, and possibly growing.

QRP is alive and healthy. It will continue to grow. We need to welcome newcomers graciously. The newcomers, along with us old timers, are the future of Ham Radio. ●●

## WRITE FOR QRP QUARTERLY

Become Semi-Famous!  
See Your Name in Actual Print!

It's easier than you think to become a QRP Quarterly author...First, you DO NOT need to be great writer (that's why we have editors). Just describe your project or activity in a logical, step-by-step manner. Find an article in a past QQ on a similar topic and use it as a general guide. Then, have a friend read your article to make sure you have included all the necessary information.

We DO need you to be organized — collect all the necessary drawings, graphs and photos that go with your article and save them as computer files, using a common format such as JPEG for photos, TIFF for drawings. Many hams are experienced computer users, and you can probably find a local ham to help with the 'graphics.' We can accept many (but not all) graphics formats—check with us if you have questions.

Remember, magazine printing is much higher quality than a web site. The typical 72 dots-per-inch (dpi) for web publishing is NOT good enough for a magazine. 300 dpi is fine, line drawings are even better with 600 dpi. When saving photos as JPEG, use the minimum compression setting.

E-mail manuscripts to the Managing Editor: [mgoins@usa.net](mailto:mgoins@usa.net)

# Idea Exchange

## Technical Tidbits for the QRPer

Mike Czuhajewski—WA8MCQ

wa8mcq@comcast.net

### IN THIS EDITION OF THE IDEA EXCHANGE:

*A Digital Voltmeter with Audible "Display"*—Joe Everhart, N2CX

*Ignore Color Codes on IF Cans*—Paul Harden, NA5N

*MFJ Manuals Available on the Web*—(DK3RED)

*MFJ-259(B) Info on the Web*—(DK3RED)

*Heathkit Schematics Online*—WA8MCQ

*Good Info on the Elecraft Mail Reflector*—WA8MCQ

*I/O Expander Adds Useful Functions in Small Projects*—George Heron, N2APB

*Amplifier for 40M Milliwatt Rigs*—Jake Carter, N4UY

*Decoupling Capacitor Rules of Thumb*—Dave Fifield, AD6A

*Duct Tape as Insulation*—Bob Melville, K3WRV

*AM/SSB Reception on the DSW Rigs*—Bill Mabry, N4QA

*Another HW-8 Toroid Success Story*—AA3SJ, WA8MCQ

*Frequency Alignment of TenTec 13xx Rigs*—Dennis Doran, WB8WTU

*Microminiature QRP Crystals and FT-817 Filters*—WA8MCQ

*QRP Online*

### Quickie #43, A Digital Voltmeter with Audible "Display"

QRP Hall of Fame member and one of the technical heavyweights of the New Jersey QRP Club, Joe Everhart, N2CX, presents #43 in his endless series of Technical Quickies—

This Quickie is the first in a hopefully long series that describes applications using the N2APB QuickieLab. The QL (for short) is introduced by George elsewhere in this issue and is a kind of junior version of the HC908 Digital Breadboard recently described in the separate N2APB *QRP Quarterly* column Digital QRP Homebrewing.

Briefly, the QL is a microprocessor breadboard based on the Parallax Basic Stamp—in particular the Basic Stamp II. It allows breadboarding of simple microcontroller circuits and easy programming of them using the simple language PBASIC.

A big advantage of the QL vs. N2APB's HC908 Breadboard is that the QL is a nearly self-contained system. All you need to program it is a Windows computer with a free program called basicw.exe (Ref 1). You can even program the Basic Stamp from the small Poquet computer using the supplied DOS program. You don't need any other fancy assemblers or development systems and

you don't have to worry too much about the low-level details involved in assembly language programming. George's Digital Breadboard is a powerful application development system but much of its power comes from working in assembly language.

On the other hand using the QL is not a free ride—quite literally. The Basic Stamp chip itself is \$49 and any project you build beyond the QL requires a new one. Of course if all you use is the QL, that's not a problem. Duplicating projects developed on the HC908 Digital Breadboard in other forms starts with the '908 chip which is much less expensive and more powerful than the Basic Stamp. So the tradeoff is ease of programming in a somewhat expensive chip with limited power (i.e., the Stamp), or programming in assembly language on a fully functional microcontroller chip (the HC908).

I submit that there is room for both options. In fact I find it easier to do early development quickly with the

Stamp, then "port" the project to a '908 or PIC for the final incarnation.

For some time now George and I have been discussing how to best introduce microprocessor applications to the QRP homebrewer world. There has been feedback indicating that his powerful HC908 Digital Breadboard is intimidating for some beginners. The QL, on the other hand, is intended as a stepping stone to introduce microcontroller applications and programming without being too stressful.

We hope that it will encourage its users to become interested in this fascinating facet of homebrewing and become proficient. And once proficient with this beginner's tool, perhaps they will "graduate" to the more powerful assembly language applications possible with the Digital Breadboard. Beyond its utility as a learning tool, the QL is also a convenient tool to quickly check out software routines and microcontroller application feasibility. Once an idea is proven to work, it can then be implemented on a larger, more powerful system.

George fully describes the QL elsewhere, but for completeness I'd like to briefly mention some of its features. Its heart, of course is the Parallax Basic Stamp-II (BS2) chip. Also on-board are a voltage regulator, a circuit breadboarding plugboard, several pushbutton switches, a number of individual LEDs and a small speaker. Additional features are accessed through a pre-programmed Scenix SX-28 I/O expander. This give access to an on-board A/D converter, a digital potentiome-

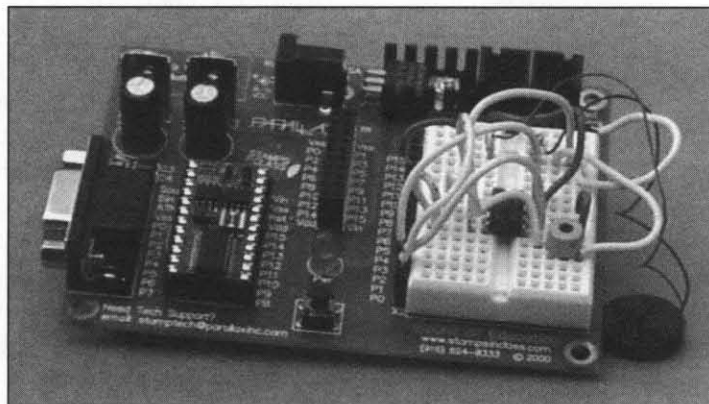
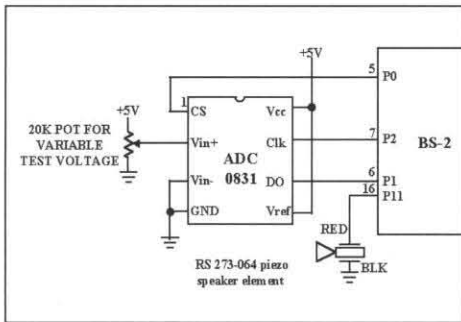

Figure 1—Quickie 43 on Parallax BOE.



**Figure 2—Simplified Audible Voltmeter schematic diagram.**

ter, a keypad, a liquid crystal numeric display and a frequency counter input. And there are provisions for plug-in “daughter boards” being developed for the Digital Breadboard.

This Quickie is a sample application to show how easily a unique function can be done with the Basic Stamp. It does not use the full power of the QL so it can be duplicated with little more than the BS2 chip. This “proof of concept” implementation was made using the Parallax Board of Education (BOE) as shown in Figure 1.

Ok, but what is this sample application? It’s a digital voltmeter with an audible “display.”

The Audible Voltmeter accepts DC inputs up to 5 volts and provides either of two audio outputs. In the same way a typical analog voltmeter moves a needle across its face, the Audible Voltmeter can produce a tone whose pitch depends on the voltage it’s measuring. Voltages near zero produce a low pitch that rises to over 2.6 kHz at full-scale inputs of 5 volts. This mode is handy for peaking or nulling a voltage as with an analog meter.

The user-selectable output is a numeric voltage indication but rather than a visual display, the indication is sent as three digits of Morse code. It consists of one digit indicating whole volts, the character R as a decimal point, one digit for tenths of volts and finally one for hundredths of volts. So 0.12 volts would be heard as “0R12” and 4.95 volts is “4R95”, etc.

Figure 2 is a “bare-bones” schematic diagram of the Audible Voltmeter. It shows the BS2 chip connected to a National Semiconductor ADC0831 (Ref 3) analog to digital converter, a pushbutton switch and a piezo-electric “speaker.” The figure also shows a trimpot that provides a variable DC input to the A/D converter for test-

ing. Not shown are the other BS2 connections for programming through an external computer and input power. These are provided by either the BOE in this example or the QL if that is your choice.

Operation is simple. The program is first loaded via an RS-232 interface from your computer. See Ref 2 for the program “AUD\_VM.BS2.” The program will be stored in non-volatile memory in the BS2 chip and will automatically run whenever power is applied. The program defaults to the Morse output mode and will continuously sound out the A/D input voltage at 12 wpm as long as the chip is powered—gets kinda old after a while...

To switch over to the variable tone mode, press the pushbutton switch until you hear a continuous tone. The tone’s pitch will vary depending on the A/D input voltage. Actually the tone is almost continuous. You can hear a brief pause every time a new A/D reading is taken. To switch back to the Morse output mode, press the switch again. Thus the switch lets you toggle back and forth between the Morse and variable tone modes at will. Remove BS2 power to turn off the Audible Voltmeter.

I won’t bore everyone with a program listing in this Quickie. A block diagram of the program and its listing are available for download on the NJQRP web site (Ref 2.) For those without web access, a hard copy is can be obtained by sending a business-size SASE to N2CX at the address listed at the end of this article.

While the complete listing isn’t here,

Number or Character	Morse Pattern	Byte Representation
1	.-.-.	01111100
2	..---	00111100
3	....-	00011100
4	....-	00001100
5	.....	00000100
6	-....	10000100
7	--...	11000100
8	---..	11100100
9	----.	11110100
0	-----	11111100
R	.-.	01010000

**Figure 3—Morse representation in computer memory.**

the routine used to provide a the Morse code output is rather interesting so I will lift the hood, so to speak, and show how it works.

A recent discussion on the QRP-L e-mail reflector dealt with how to encode Morse characters into a single binary string. One ingenious method was described in that thread by Glen Leinweber VE3DNL. In the method he describes, a dit is represented by a binary “0” and a dah by a “1.” So the digit “2,” which is ..--- in Morse encodes as 00111. Now to store them in a computer memory the 1s and 0s are inserted in order into eight-bit “bundles” called bytes. Numerals “1” through “0” have only 5 elements so there are three extra bits. To fill out the byte, the last valid Morse bit is followed by bit characters and 0 fill out the remaining slots. Figure 3 shows this representation for numerals 1 through 0 and the letter R. They are arranged in “0-9” order to clearly show the resulting patterns.

OK, so now you have the bits all packed up neatly in bytes, how do you get them back out? Figure 4 is a block diagram of that routine.

First, the bit pattern for the Morse character is obtained by reference to a table arranged as in Figure 3. In it the Morse character bit pattern corresponds to the location in the table. Thus the pattern for numeral “0” is in the 0th location, “1”’s pattern is in position 1, 2’s is in position 2, etc. A slight mental readjustment is necessary, as is often the case with computers

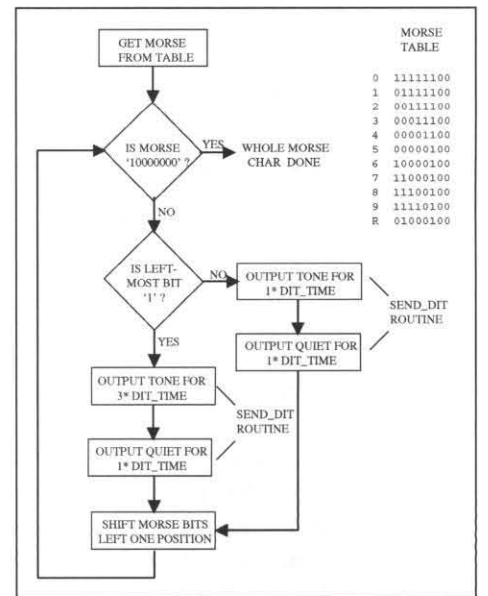

**Figure 4—Morse sending routine.**

since there is a 0th position in the table. The pattern is stored as variable MORSE. For this example, let's assume that we want to send the numeral "1." The pattern stored in MORSE is then 01111100.

Next a check is made to see if the character is finished being sent. As we will see later, this occurs when there is a single bit "1" in the leftmost position in MORSE. When this pattern is recognized we know that the whole character has been sent. Keep that though in mind as we go through this description. Since we just loaded 01111100 into MORSE the result of the comparison is NO.

Following the YES path we drop down to another decision block. This time we check to see if the left-most bit in MORSE is a "1" bit. Since we have not changed the original MORSE pattern the answer is NO. Having a "0" bit means that the first MORSE character to be sent is a dit so this path takes us the DIT ROUTINE.

The DIT ROUTINE simply sends out a tone to the voltmeter's piezo speaker for one DIT\_TIME then it times out a silent period of the same length. In this program the Morse characters are sent at 12 wpm so there is a tone for 100 ms followed by silence for 100 ms (actually there is a little more silent time than that but it is so short that it is not noticeable.)

Now that the DIT has been sent we remove the bit just sent from the MORSE pattern by doing a left shift. Each bit in MORSE shifts leftward and a "0" bit is added on the right hand side. The "used" bit that was on the left is shifted out into never-never land. MORSE now has the pattern 11111000.

The program now returns back up to the top where MORSE is once again checked to see if the whole character has been sent. You can see that the modified MORSE character does not match the pattern checked for.

But there is something different now when we enter the next decision block. This time, since the left-most bit is indeed "1" we exit via the YES path into the DAH ROUTINE.

This is much the same as the DIT ROUTINE except that a tone is sent for three DIT\_TIMES followed by a single DIT\_TIME silent period. This obviously is the dah we all know so well.

The program then shifts out the "used" bit and starts all over again. It proceeds

sending out dits and dahs as we have seen above until we have used up and discarded all of the bits we are interested in are used and the remaining pattern is 11111000. Which tells the program that the whole character has been sent and it can go on to its next task.

For a fuller understanding of how the entire program works please refer to the listing on the NJQRP web site as listed in Reference 2.

You have now seen how the Basic Stamp chip and a couple of other components can be assembled and programmed to come up with an audible readout voltmeter. By itself it has some limitations that can limit its usefulness. So think of it as a starting point. And on that note, check out Test Topics and More in this issue of the *QRP Quarterly*, where this basic circuit and program are augmented to make a more generally useful test equipment building block.

#### References:

1. The Basic Stamp, Board of Education and PBASIC software are all described on the Parallax, Inc web site at [www.parallaxinc.com](http://www.parallaxinc.com).

2. The Quickielab and a series of related projects, tutorials and complete program listings for QuickieLab programs can be found at [www.njqrp.org/quickielab](http://www.njqrp.org/quickielab)

3. A data sheet for the ADC0831 is available from National Semiconductor Inc through their web site at: <http://www.national.com/ds/AD/ADC0831.pdf>. You can purchase them for less than \$3.00 each as an ADC0831CCN (8-pin DIP) from Digikey and others mail order distributors.

—Joe Everhart, N2CX  
214 New Jersey Rd  
Brooklawn, NJ 08030

#### Ignore Color Codes on IF Cans

Small IF transformers have been used in homebrewing for a long time, and recently someone on QRP-L asked for a definition of their color codes (the adjustable cores on many of them have various colors). Unfortunately, according to this reply by QRP Hall of Fame member, Paul Harden, NA5N, ([na5n@zianet.com](mailto:na5n@zianet.com)), it turns out that they're just like toroidal cores—there is no industry standard color code and you can't go by the color unless you know who made it. Paul says:

The color coding used on IF cans tend to be manufacturer dependent. There is no standard that green means this, orange means that. If you know the specific manufacturer (Toko, Coilcraft, etc.), you can find this information on their websites. The IF cans from Mouser are color coded, and shown in their catalog and on their website.

The original purpose of the color coding was NOT to indicate any particular value in  $\mu\text{H}$  or something, but rather to make them easily recognizable by those inserting them into circuit boards for radios, TVs and CBs. It was so they wouldn't get the wrong IF cans plugged into the wrong spot on the boards. However, since components on most electronics today are all machine inserted and wave soldered, the color coding is less important (for industry, anyway).

Unfortunately, the colors have no meaning unless the exact manufacturer is known.

—DE NA5N

#### MFJ Manuals Available on the Web

Did you ever buy a used MFJ product that didn't have a manual? Or maybe something from Hy-Gain, Vectronics, Mirage or Ameritron? You might be able to find it on the web. Ingo Meyer, DK3RED, posted this URL on the GQRP mail reflector:

<http://www.mfjenterprises.com/manuals.php>

This is the Manuals section of the MFJ web site, where information on many of their products is available. Scan down the page and you'll see a pair of columns. Click on the model number in the left column ("Model") and you'll get an overview of the item. Click on the right column ("View PDF") and you'll get the manual (I checked a number of them, and none seem to contain schematics).

Along the top of the page are buttons for related companies—Hy-Gain, Vectronics, Mirage and Ameritron. If you go to those pages and poke around a bit you'll find a similar list of their products and manuals. (Again, no schematics were found.)

All manuals are in the Adobe Acrobat PDF format. If you don't have a copy of the free reader (currently on Version 5),

you can download a copy from the link on any of these pages.

### MFJ-259(B) Info on the Web

Ingo Meyer, DK3RED, was sent some scanned documents for the MFJ-259B (note the B) and put them on his web page:

The schematic is at <http://www.qsl.net/dk3red/mfj259b-sch.jpg> (578 kB).

A calibration procedure is at <http://www.qsl.net/dk3red/mfj259-cal.pdf> (149 kB).

Additional info on the 259B is at <http://www.qsl.net/dk3red/mfj259b.zip> (1426 kB).

He also said that the schematic for the MFJ-259 (without B) can be found at <http://www.qsl.net/dk3red/mfj259.zip> (313 kB) and the test/calibration procedure at <http://www.qsl.net/dk3red/mfj259test.zip> (429 kB).

(Ingo posted this information on the GQRP mail reflector.)

### Heathkit Schematics Online

I stumbled across an Internet site recently which has schematics for a wide variety of Heathkit items, including the HW-7, HW-8 and HW-9. They are broken up into a number of files; the HW-7 is split into 4, the HW-8 into 8, and the HW-9 into 9 (the latter appears as a single file on the site, but it's actually a ZIP file). They are in GIF or TIF format, depending on which rig you're looking at, and you'll have to paste them together if you want to look at the entire schematic at once.

The site has schematics for some of their other rigs, too, including several in the HW and SB series.

<http://www.circuitarchive.co.uk/heath.htm>

—DE WA8MCQ

### Good Info on the Elecraft Mail Reflector

Some time ago the Elecraft folks set up a mail reflector for users of their products. I've been subscribed to it for a few months now out of curiosity, even though I don't have any Elecraft products, and it's quite active. There is a lot of good info about their rigs, as well as a lot that is useful even if you don't have one.

The reflector gives the option of receiving messages as soon as they are posted or receiving them in digest mode once a day. To subscribe to the reflector, go to:

<http://mailman.qth.net/mailman/listinfo/elecraft>

There's also a lot of material on their web page, at <http://www.elecraft.com/>. Among other things, you can check out all the archives of the mail reflector, download their manuals in PDF format and read various technical articles. Even if you don't own an Elecraft and don't plan to, their web site and reflector are definitely worth checking out. If you do own an Elecraft, these are THE places to go for mods, fixes, tips, etc.

—DE WA8MCQ

### I/O Expander Adds Useful Functions in Small Projects

Here's Micro Moments #2, the N2APB answer to the N2CX Quickies. George Heron is one of the guiding lights of the NJQRP Club, and a recent inductee into the QRP Hall of Fame. This month's MM goes right along with his separate QuickieLab article, his Digital QRP Homebrewing column, and both the TTAM column and Quickie from N2CX.

Input and output pins are very precious resources in small digital projects these days. Our favorite small microcontrollers like the PIC, 8051, SX, BASIC Stamp, etc., may only have 8-to-16 lines of I/O available for use, while we typically have a need to drive LCD displays, LEDs and frequency synthesizers; and read A/D converters, keyboards, shaft encoders and more. Hardware interfacing is the name of the game, and you can never have too much I/O capability on a processor to handle all these tasks.

Well, here's a relatively simple project called the I/O Expander, or IOX for short, that will greatly ease that I/O pin crunch on your current microcontroller project. At first it looks like a clone of the common "serial LCD" controller – but when you look at the specs under the hood, you'll see an I/O processor that's chock full of goodies that we use everyday in our ham applications: serial display driver, frequency counting, A/D conversion, keypad processing and digital potentiometer control. Drop this single

chip IOX into your next design and you'll be able to handle a lot more I/O than you originally thought possible.

A Ubicom SX-28 is programmed to be controlled by the host microcontroller of your project over a simple 2-wire serial protocol, thus acting as the host's "henchman" in performing various I/O functions. The host (e.g., your PIC) issues a simple 1- or 2-byte command over this serial link and the SX processor goes off and does its thing. Sometimes the SX outputs the specified data (to the display or digital pot), while at other times it gathers input data (from the frequency counter, A/D converter, or keypad) and sends it back to the host over that same serial wire protocol.

The block diagram of Figure 5 illustrates this master-slave concept for expanding the I/O capabilities of a host microcontroller. For details of one implementation of the I/O Expander, see the QuickieLab schematic elsewhere in this issue and you'll see how easy it is to design it into your next project.

### Operation as a Serial LCD Driver:

The SX chip takes a byte in the range of 0-to-253 delivered by the host and displays it on the LCD display connected to its own I/O pins. When a special "command" byte of 254 is sent by the host, the SX chip waits for another character which is called the function byte. As can be seen in Table 1: I/O Expander Command-Response Structure, display functions include clearing the display, setting the cursor to home or to a prescribed position, blank display, scroll the display, and more. Thus when the host processor sends a 2-byte sequence of 254 and 1, the display will be cleared of all data.

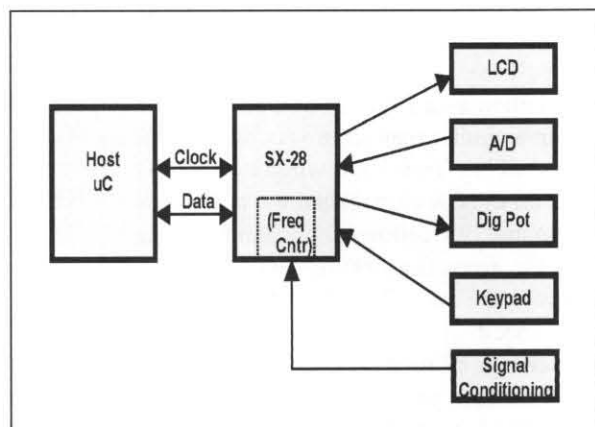

Figure 5—Block Diagram of I/O Expander in a System.

### Operation as a Frequency Counter:

Since the IOX software is often just sitting around waiting for some command from the host processor, I decided to make use of this idle time with a frequency counting routine. In fact, the IOX software is designed to always count the frequency being applied to its RTCC input pin. Whenever commanded by the host to "read frequency" (command 64 in Table 1), the SX chip sends back the most recent two-byte representation of the applied signal's frequency. The algorithm is very similar to the measurement routines used in other projects, including the "Antenna Analyzer I" project that N2CX and I did back in 1998.

The software counts transitions on the RTCC pin of the SX chip, and accumulates the counts in two internal storage locations. Based on the time base (command 65) issued by the host processor, the measurement window is shortened or lengthened and the host then multiplies the numbers accordingly after being receiving them from the SX. In this way frequencies from audio to 30 MHz can be measured.

### Operation as an A/D Controller:

As shown in the detailed schematic of the QuickeLab, a popular and inexpensive analog-to-digital converter is wired to the SX chip's I/O pins. The IOX software is able to initiate A/D conversions and read the resultant 8-bit data representing the analog signal on the ADC inputs. So if the host processor commands the SX chip to read the A/D (command 80), the I/O Expander initiates an A/D read cycle, awaits data conversion completion, and returns the 8-bit value to the host in response. The host then needs to process that value ranging from 0-to-255 into some meaningful data within its own program.

### Operation as a Digital Pot Controller:

In a similar manner, a very useful chip called an NV Trim Pot is wired to other I/O pins on the SX chip. When the host sends command 90 followed by another byte ranging from 0-to-99, the IOX software "moves the wiper" of that digital pot to that specified position (corresponding to percentage of rotation of the pot). In this way the host processor can easily control the gain of an amplifier, for example, if the digital pot is wired into the feedback loop of an op-amp.

### Operation as a Keypad Processor:

The IOX software running in the SX chip may be commanded by the host to read a 4 row by 3 column keypad in one of two ways. First, command 100 instructs the IOX software to merely return the current state of the keypad. If a key is pressed, a binary value in the range of 0-to-12 corresponding to that key is returned to the host as a response byte. But if no key is currently being pressed, a response value of 255 is sent back to the host.

A more conventional mode, initiated by the host sending command 101 to the SX chip, instructs the IOX software to send a key code whenever a key is pressed. This asynchronous operation of sending

unsolicited data back to the host is useful in the respect that key presses can initiate operations while the host software is off doing something else. This is like having 12 user-selectable interrupts, and is a powerful addition to the hardware/software developer using the I/O Expander.

### 2-Wire Serial Communication Protocol:

Host commands and IOX responses are exchanged by means of a simple 2-signal protocol using "clock" and "data". In the command mechanism, the host sequentially presents the data bits it wishes to send to the SX chip, on the "data" line, in least-to-most-significant bit order. For each bit it presents, the host delivers a negative-going

COMMAND	FUNCTION	RESPONSE
<b>LCD:</b>		
1	Clear LCD Screen	ACK
2	Home cursor on LCD	ACK
8	Blank LCD (retains data)	ACK
12	Hide LCD cursor	ACK
14	Show underline cursor	ACK
16	Move cursor 1 character left	ACK
20	Move cursor 1 character right	ACK
24	Scroll 1 character left	ACK
28	Scroll 1 character right	ACK
128+location	Position the cursor	ACK
128	Move to 1st character of 1st line	ACK
128+n	Move to nthcharacter of 1st line	ACK
192	Move to 1st character of 2nd line	ACK
192+n	Move to nthcharacter of 2nd line	ACK
64+address	Set character generator address	ACK
<b>FREQ COUNTER:</b>		
64	Read frequency	MSB, LSB
65, n	Set time base in ms (n= 8, 16, 32, 64, 128, 255)	ACK
<b>A/D:</b>		
80	Read A/D	Byte
<b>DIGITAL POT:</b>		
90, n	Set pot wiper to n (0-to-99)	ACK
<b>KEYPAD:</b>		
100	Read Keypad Byte	(0-11)
101	Keypad interrupt ON	ACK
102	Keypad interrupt OFF	ACK
103, n	Keypad interrupt response	Byte (0-11)
<b>SYSTEM:</b>		
200	Reset I/O Expander software	ACK

Table 1—I/O Expander Command-Response structure.

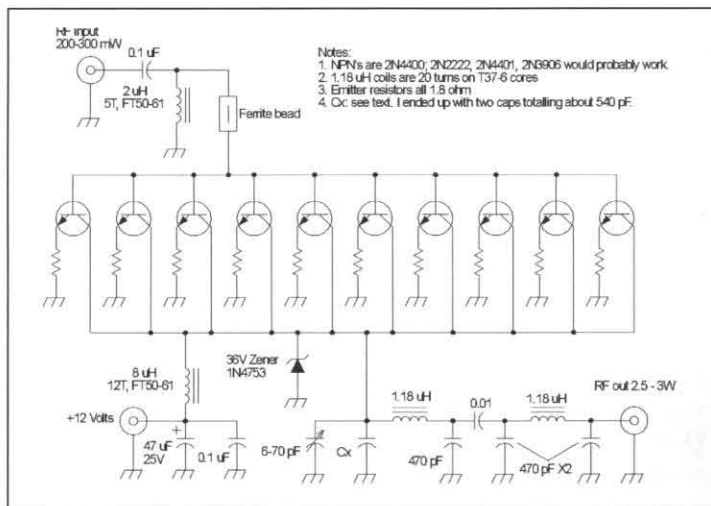

**Figure 6—The N4UY amplifier. (Although he used 13 transistors, only 10 are shown here.)**

pulse on the “clock” line that instructs the IOX software to read that data bit into a software accumulator. Once all eight bits are read, the SX chip sends a negative-going strobe back to the host in acknowledgement, using the response mechanism. In the response mechanism, the situation is reversed and the IOX software sequentially sets the “data” line with the bits of the response data and strobes the “clock” line to instruct the host to read the data bit. An acknowledge strobe is sent back to the SX chip once the byte has been successfully received.

This simple protocol makes two important assumptions: (1) the host processor’s “clock” and “data” I/O bits must each be bi-directionally settable and they must be quickly changeable to serve in this protocol; and (2) the timing of the pulses is known (and configurable) such that we can depend on certain “data valid” times to allow the I/O bits to be reversed. When the host processor is fast, such as with a PIC, this turnaround time can be quick and the resulting command-response speed of communication with the I/O Expander is correspondingly quick. The protocol also works with a slower processor, such as with a BASIC Stamp, but the 2-wire serial exchanges are commensurately slower too.

### Go Forth and Expand (your I/O)

By using the I/O Expander, you can easily control more hardware peripheral devices than possible with just a PIC, Stamp or 8051 microcontroller. An even more attractive feature is that the software

is simplified too – you needn’t worry about A/D conversion, frequency measurement or LCD coding intricacies... it’s all there in the SX chip for you. The IOX source code is provided on the project’s website ([www.njqrp.org/ioexpander](http://www.njqrp.org/ioexpander)) and you can add/change routines in support of your own favorite peripheral. If you don’t wish to program the SX chip on your own, you can order it from the NJQRP (see note at end). Any way you look at it, it’s easy to “go forth and expand your I/O”!

*Note:* An SX-28AC/DP microcontroller, programmed with I/O Expander software, may be obtained by writing a check or M.O. for \$15 payable to “Dave Porter, AA3UR” and sending to: Dave Porter AA3UR, 647 Middle Holland Rd, Holland, PA 18966. Payment is also accepted by PayPal sent to [njqrp-kits@comcast.net](mailto:njqrp-kits@comcast.net). Price includes shipping to US & Canada. DX orders add \$5.

—DE N2APB  
[n2apb@amsat.org](mailto:n2apb@amsat.org)

### Amplifier for 40 meter Milliwatt Rigs

Jake Carter, N4UY of Vienna, VA, has this 40 meter amplifier posted on his web page. It’s handy for boosting the power of rigs running a few hundred milliwatts, and can put out 2 or 3 watts. The picture here is black and white, but if you’d like to see it in color you can go to

<http://mywebpage.netscape.com/jakeycarter/4400amp.html>.

My amp is adapted from Doug DeMaw’s



**Figure 7—Strips of PCB material glued to the board provide connection buses for the bases and collectors.**

design described in the November 1979 *QST* article “Basic Amateur Radio—Transmitter Fundamentals.”

In that article Doug provides a schematic for a simple 40 meter transmitter. The transmitter’s PA stage consists of 4 parallel 2N2222s, each with a 1.8 ohm emitter resistor. I adapted his design by adding a few more transistors and using a slightly modified version of the NJQRP Club’s FireBall 40 amp low pass filter.

The RF enters through a 0.1 uF cap and a small ferrite bead to the PA transistors. A 2 uH inductor provides a DC return for the bases. 12 volt is applied to the collectors through an 8 uH choke. A 47 uF electrolytic cap and 0.1 uF cap bypass unwanted signals from the V+ source to ground. I used 13 2N4400’s in my amp; that’s all I could comfortably fit on the PC board base. I put 1.8 ohm resistors from each transistor’s emitter to ground.

I used the output filter from the NJQRP club’s Fireball 40 Amp. (The manual for that can be found on the NJQRP web page at: <http://www.njqrp.org/fireball40/fb40amp.pdf>.) Their manual calls for 450 pF of total capacitance (C15, et. al.) at the final transistor’s collector. I substituted a combination of capacitors totaling 540 pF (in addition to a 70 pF trimmer) for C15. I adjusted the total C15 capacitance until I got a nice output pattern on my scope and two peaks as I turned the trimmer cap through 360 degrees. [As someone mentioned several issues back, with a trimmer cap you should always see two peaks in the signal when turning it through a full 360

degrees. If there is only one peak, it indicates that the trimmer cannot properly tune the circuit. If it peaks only at minimum capacitance, there is too much capacitance in the circuit already. Yes, there is a peak, but it is probably not the maximum possible. Removing some capacitance in the external circuit will allow the trimmer to properly tune the signal to maximum.

If the signal only peaks at maximum capacitance, that indicates that there is insufficient capacitance in the circuit. With adequate capacitance, the trimmer will peak somewhere between the two ends, and then pass through that point again before completing a full turn. —WA8MCQ]

I initially included a Zener diode to protect the transistors but had difficulty adjusting the total C15 capacitance with the diode in the circuit, and my output was lower than I expected. I disconnected the diode and was able to adjust the C15 capacitance. I don't think the diode is necessary with 13 2N4400's—they stay cool driven with 300 mW.

The output is about 2.5 watts with 200 mW drive and a bit less than 3 watts with 300 mW drive, with power supplied by a 12 amp/hr gel cell.

For further reading check out "Low-Cost QRP Power Boosters" by Doug DeMaw, W1FB, *QST* July 1987 pp. 30-34; and "Parallel Small-Signal BJTs for More Power" by Doug DeMaw, W1FB, *Sprat* 91, p.25.

—DE N4UY  
jakecart@ix.Netcom.com

### Decoupling Capacitor Rules of Thumb

Someone on QRP-L posted a shopping list of parts to stock up on at hamfests, and included 0.1  $\mu$ F ceramic capacitors for use in DC power supply line decoupling (such as the N4UY amplifier shown in Figure 6). One of the NorCal technical gurus, Dave Fifield, AD6A, had this reply -

0.1  $\mu$ F caps are typically only good until about 20 MHz, when they start to become inductive. Twenty MHz is their self-resonant frequency (SRF). 0.01  $\mu$ F caps have a typical SRF of 100 MHz and 1000 pF caps of a few hundred MHz. A rough rule of thumb would be that 0.1  $\mu$ F capacitors are good for decoupling at 160 meters, 80 meters, 40 meters and 30 meters only.

If you are doing homebrew at 20 meters and above, I recommend decou-

pling with more than one capacitor. From 20 meters to 6 meters, I'd use 0.1  $\mu$ F in parallel with 0.01  $\mu$ F and for 2 meters/1.5 meters use 0.01  $\mu$ F with 1000 pF. For 70 centimeters, you should use 1000 pF with 100 pF.

Place the decoupling caps right next to each other. If you space them out, there is the possibility that you could unwittingly create VHF resonances that, far from decoupling signals to ground, actually increase signals on the power rail you are trying to decouple at certain frequencies.

[Additional WA8MCQ notes—Another rule of thumb when choosing a DC power supply line decoupling capacitor is to make sure they are ceramic. Due to different construction, other types of capacitors could have significantly lower SRFs. The SRF of a capacitor is the frequency at which it resonates with its own internal inductance. Up to that frequency the capacitor acts as a capacitor, but acts as an inductor above it.]

—DE AD6A  
dave@redhotradio.com

### Duct Tape as Insulation

Whenever we use duct tape ("duck tape") we usually assume that it's an insulator, but that's not always the case. Bob Melville, K3WRV, sent this note—

In his Quickie #42 in the July 2002 Idea Exchange, N2CX talks about using duct tape to insulate the terminals of a 12 volt battery. This may be a problem.

Apparently, there are two kinds of duct tape. One is the type actually used by the HVAC professionals when doing duct work, which I'll call type 1, and the type you can buy at Ace hardware, which I'll call type 2. The former is fairly shiny, and appears to have a metallic foil surface. If you look at the ducts in your basement, this is probably what the installer used.

I measured the resistance of a 3" spool of the stuff across the diameter and it was zilch. (My DVM won't read below 0.1 ohms). I then hooked my Radio Shack 1.5 amp power supply across the same roll, and blew the circuit breaker!

The type 2 stuff on a six inch roll measured infinity on the 20 kohm scale, and I assume this is what Joe used as insulating tape, and probably works okay (I'd been meaning to check it out for some time, and finally did). Both types look about the same, although there are more "fabric

lines" showing in type 2.

Moral of the story? If you're going to use duct tape to insulate things, check it with a VOM first!

By the way—does anybody remember using "slide binding tape" (another metallic variety) for making window antennae back in the 1960's? You simply cut a dipole or vertical out of the stuff, taped it on a window or in a bathroom, hooked one end of the coax to the antenna and the other to the plumbing or a ground. It worked fine at the 10 watt level. I think I first saw it in *Popular Electronics* or *Electronics Illustrated*.

—DE K3WRV  
bmelville@juno.com

### AM/SSB Reception on the DSW Rigs

For a while, QRP Hall of Fame member Dave Benson, K1SWL of Small Wonder Labs, produced some monoband CW transceivers with direct digital synthesis (DDS) VFOs, called the DSW series. Designed for CW, they have nice, sharp filters made from computer clock crystals. But sometimes people like to listen around the bands as well as operate, and this makes it difficult to receive other modes. Here's a simple modification posted to QRP-L by Bill Mabry, N4QA. This technique should also work with any other filter made from a batch of selected computer crystals, although some experimentation might be necessary to get the desired results. Bill says—

For a couple of years now I've been receiving AM/USB/LSB signals with my DSWs by bypassing Y1 and Y2 (the first two IF crystals). This may be done with an on-off switch connected from the 'input' side of Y1 to the 'output' side of Y2. Switch off for normal CW reception, and switch on for AM/USB/LSB reception. This allows sufficient passband without leaving the IF WFO (Wide Full Open), which not only passes on-frequency AM/USB/LSB signals but just about everything from everywhere else as well.

This mod is a little trickier to do [than some] since one must gain access to the bottom of the circuit board.

—DE N4QA  
n4qa@hotmail.com

### Another HW-8 Toroid Success Story

I received e-mail from Ed Kessler, AA3SJ, telling me about his recent pur-



chase of an HW-8 at a hamfest. When he checked it out he found that the receiver was working fairly well on 20 meters and 15 meters but dead on 80 and 40. He aligned the rig and now the receiver works well on all bands. However, one of the bands had low output power.

"When I keyed the transmitter to align it, I discovered that I had 2 watts on 80 meters, 1.5 watts on 20 meters and 1 watt on 15. However, I "ran out of minimum capacitance" on 40 meters and could only eke out about 450 mW. On a hunch I removed the toroids from the 40 meters filter section and measured them using an AADE L/C meter. They both measured almost exactly 8.5  $\mu$ H, 1.5  $\mu$ H more than specified. So I wound some T50-2 cores to 7  $\mu$ H and installed them. After tuning, the rig now puts out 2 watts on 40 meters as well.

"Tonight I came across your article from the early 90s on the toroid changes in the HW-8 and found them to be quite interesting. I thought I'd write and tell you that you can add my rig to your stats. Interestingly, the 80 meter section looks original and still works fine."

I always enjoy hearing about another HW8 fixed by replacing the output cores, but I quit keeping track of the number of cases when it hit 10 about six years ago. When I first discovered this problem I wondered whether it was an isolated instance, but over the years it became obvious that's not the case.

About ten years ago I reported on an interesting phenomenon—the ferrite toroid cores used in the 80 and 40 meter output networks of the HW-8 can go bad, lowering the output. Specifically, the permeability increases for some unknown reason, raising the inductance and throwing the tuning point of the network away from the band. Between that and the accompanying increase in core loss, the output is reduced. The cure is to replace the cores. I always advocate replacing them with the same type used originally, a ferrite with permeability of 40, although some people have successfully used type 2 powdered iron, as Ed did.

Either way, the important thing is to replace the bad cores. As I noted in the original article, simply removing turns to bring the inductance back to normal doesn't do a lot of good. Although the inductance is back to where it should be, the bad

cores still have elevated loss, holding back some of the power. It's far better to just get them out of there.

Interestingly, Heath used type 2 powdered iron cores (or something very similar) for 20 and 15 meters, and they do not exhibit this shift in permeability. Or if they do, it's not enough to be noticeable. Over the last 15 years I've had the opportunity to test between two and three dozen HW-8s on the bench, both at home and at my former part time job in a ham store. I never saw any case where significantly low output on 20 or 15 could be attributed to bad cores.

I did some experiments long ago (also reported in the Idea Exchange), zapping perfectly good ferrites and making them go bad, and tried the same thing with powdered irons. The change in characteristics of the ferrites was dramatic, but the shift in the powdered irons tested was so slight that it would have gone unnoticed if I had not done before and after measurements for comparison. The zapped powdered iron toroids had what appeared to be perfectly normal inductance and Q when measured on my Boonton 260A Q meter. The numbers were not in the least suspicious, but since I recorded both before and after values the difference could be seen.

The July 2001 Idea Exchange contained detailed coil winding information on replacing the entire set of HW-8 output coils, including the two bands that can go bad. If anyone needs a copy of the info, please contact me.

—DE WA8MCQ

### Frequency Alignment of TenTec 13xx Rigs

In a post to QRP-F, Pat O'Brien, K8LEN, asked if there was a simple way of aligning the TX/RX frequencies in the TenTec 1320. He said that he had followed the manual, using a separate receiver, but had no contacts and presumed that things were still off frequency. Dennis Doran, WB8WTU, had this reply:

Having worked on many of those rigs in the 13xx series, here is my "Simple Alignment" sheet. It may not be perfect, but it works! I suggest you follow the steps in order. The alignment procedure in the manual is silly and confusing.

#### Tools needed:

- A. Frequency counter
- B. Wattmeter, or other device to indi-

cate power out.

*Step 1*—Connect the rig to an antenna, tune around and find a CW signal. Peak the following transformers for maximum signal strength:

L6, L18 - Receiver front end

L7 - Receiver mixer

L5 - IF Amp

*Step 2*—L1 is the receiver BFO adjustment. This sets the IF passband, pitch of the received CW note, and the opposite sideband rejection. If improperly set, you will hear both sidebands of a signal (passband too wide). [WA8MCQ note—in the case of a CW signal, you will hear the signal on both sides of zero beat.]

Adjust L1 so that only the higher sideband (higher side of zero-beat) is received. This should be where the transformer slug is near the top of the can, but not all the way up. Set the tone (pitch) that is comfortable for your ears. When properly set, you will only receive that sideband, meaning as you tune lower in freq., and pass through zero beat, very little—if any—of the opposite sideband will be heard. The higher you adjust the slug, the tighter the bandpass will be. You can hear the bandpass "compress," for lack of a better word. Once you have that set to suit your tastes, move on to step 3.

*Step 3*—L14 is the transmitter offset. It sets the transmitter to the same sideband as the receiver, so that both are close to the same freq. Close is good enough, since you will be doing this by ear.

While transmitting into a dummy load, adjust L14 until the sidetone is the same pitch as the received signal. (A signal generator is the easiest way, but an on-air signal is good; just don't transmit on top of them. Switch between antenna and dummy load.) Match the tones with L14 as close as you can by ear.

Step 2 and step 3 will put your receiver and transmitter into alignment.

*Step 4*—While transmitting into a dummy load, adjust L12 and L13 for maximum power output. At 13.8 VDC supply, power output should be approximately 4 watts.

*Step 5 (RIT adjustment)*—Place a frequency counter probe on the R13 lead closest to transistor Q4. Note the frequency in receive mode. Now transmit into a dummy load and note the freq. Turn the

RIT shaft until the frequency is the same during both transmit and receive. Turning the RIT moves the receive frequency, so match the receive frequency with the transmit frequency, which does not change. At this point, install the RIT knob so that the pointer is on the mid-scale mark at the 12 o'clock position. Tighten the setscrew. Your 13xx rig is now properly aligned.

*NOTE:* When transmitting into a SWR of higher than 2:1, the final may go into oscillation (the sidetone becomes really "raspy"). This is due to coupling between the toroids in the power output filter. Push each of these toroids, 3 of them, I think, so that they lean away from each other. This will reduce the oscillation that occurs at higher SWR. These toroids are located at the left rear corner of the board, with the front panel facing you.

The TenTec 13xx series is a classic example of how the performance of a very good QRP rig is diminished due to a poorly written manual.

*Later feedback:* The gentleman who I replied to wrote back to say he used my procedure and aligned his rig in 5 minutes.

—DE WB8WTU

wb8wtu@yahoo.com

### Microminiature QRP Crystals and FT-817 Filters

I don't run ads in this column, although I sometimes tell of interesting products I've seen, and this is one of those announcements. A while back on QRP-L someone asked about buying 40 meter crystals and David Hinerman, WD8CIV, suggested this link on the web:

<http://www.expandedspectrumsystems.com>



Figure 8—Some of the tiny crystals available from ESS.

Look under Products and click on Cylindrical Crystals. These are in tiny cylindrical cans (what we used to call "watch crystals"), 3 mm diameter (about 1/8") and 8 mm long, not quite a third of an inch. (The 80 meter crystal is 10 mm long.) See Figure 8. They're available for 3560, 7040, 7190, 10106, 10125, 14025, 14060, 14200, 21025, 21060, and 28060 kHz.

Since these are so small, I wondered how much drive power they could handle. N4ESS of ESS sent along some manufacturer data which indicates a drive level of 50 to 100 microwatts, similar to computer or microprocessor crystals. It also indicated that the crystals in this series, which goes up to 30 MHz, are all fundamental, not overtone.

He said that they should be usable in just about any solid state oscillator design but indicated that using them in a tube rig would probably be disastrous. (That's the same thing people have been saying about microprocessor crystals. Although I haven't heard of anyone experimenting to see if it's true, I would expect that the drive level in a tube rig could destroy a microprocessor crystal.)

Prices are reasonable, at \$2.95 each for one, \$2.55 each for 2 to 10, and even less beyond that. The shipping is reasonable, too, which is a rarity these days; according to their order form it's \$0.60 for first class mail. For those without Internet access, their mailing address is Expanded Spectrum Systems, 6807 Oakdale Drive, Tampa, FL 33610, USA.

Not only are the prices reasonable, but the small size could come in handy if you're building a really tiny QRP rig. (The selection of frequencies is good, too.)

Another of their products is a series of filters for the Yaesu FT-817, a very small radio which is popular with many QRPers. These are available for 300 and 500 Hz for CW, and 2.5 kHz for SSB. Their listed prices are \$105 each, which is less than the current price for FT-817 filters from International Radio. They are based on a low cost series of 455 KHz mechanical filters from Rockwell Collins. (Note—I do not own an FT-817 so can't make any recommendations on these.)

—DE WA8MCQ

### QRP Online

As I say every issue, there's been a

huge amount of QRP info flying around the Internet for years, and it's still there!

QRP-L, which I call the "QRP Daily," is the online QRP discussion forum started in 1993 by QRP Hall of Fame member Chuck Adams, K7QO (K5FO at the time). It continues to run several dozen postings per day on a variety of topics related to QRP (and, unfortunately, many not related in the least).

QRP-F is an alternative QRP forum started by the QRP ARCI in October 1999 to take some of the load off QRP-L. The forum, QRP-F, requires a web browser such as Internet Explorer or Netscape, while QRP-L is a mail reflector and only requires an e-mail account (if you go to the QRP-L home page, you can check out all the archived messages back to Day One).

To check out the online QRP world, go to these URLs:

QRP-L: <http://qrp.lehigh.edu/lists/qrp-l/> and you're at the home page where you can sign up, read the archives, etc.

QRP-F: go to <http://www.qrparci.org/> and click to enter the site, then click on QRP-F on the menu at the top.

And while you're on those home pages, don't forget to check out their lists of QRP related links; and at each link that you go to, check THEIR lists as well, since not all sites list all others. In addition to the QRP ARCI site, another excellent place to use as a jumping-off point for checking out QRP related sites is the NorCal home page, run by Jerry Parker WA6OWR, at:

<http://www.fix.net/~jparkernorcal.html>.

You'll find quite a wealth of QRP info online.

### The Fine Print

I ran out of steam writing about my diode detector experiments, but at least I've already covered the most interesting parts. I'll have more later, some day. In the meantime, if you have anything for the Idea Exchange, send it along by e-mail or snail mail. As always, nothing fancy is required—anything I can read by computer or by eye is acceptable, and I take care of any necessary editing, drawing, etc.

●●

# An HF In-line Return Loss and Power Meter

Paul Kiciak—N2PK

kiciak@juno.com

Through the use of a high performance and internally sophisticated integrated circuit, an accurate HF in-line return loss and forward power meter is possible, covering an 80 dB input power range, using four integrated circuits. Simplicity in some designs sacrifices performance. In this case, simplicity is only external and no performance is lost.

You can adjust your antenna tuner with one mW of RF and then measure up to 300 watts, or measure the passband of that filter you just built—with the same instrument!

## Measurement Overview

A block diagram for this instrument is shown in Figure 1. The in-line directional couplers provide RF power samples,  $P_{fs}$  and  $P_{rs}$ , that are 40 dB down from the corresponding forward and reflected mainline powers,  $P_f$  and  $P_r$ . The RF samples are not rectified, as done in many SWR meters, but applied directly to the log amplifiers, A1 and A2. The log amp is demodulating, in that it converts the RF input voltage to a DC output voltage that is linearly related to the logarithm of the RF input voltage.

The integrated circuit used here for the log amps is the Analog Devices AD8307 [1]. Its typical conversion accuracy is  $\pm 0.3$  dB over an 80 dB input power range. This range extends from about  $-95$  dBW to  $-15$  dBW at the log amp input. Accounting for the 40 dB coupling factor in the directional couplers, the log amp input range corresponds to a mainline power range of  $-55$  dBW to  $+25$  dBW. Converting from dBW to watts results in a measured mainline power range of 3.16 microwatts to 316 watts, accurate to about  $\pm 7\%$ !

The high impedance log amp outputs are buffered by unity gain amplifiers, A3 and A4, to eliminate errors caused by loading of the subsequent stages. After calibration, the mainline forward and reflected powers in dBW are related to the unity gain amplifier outputs by:

$$P_{f,dBW} = K_1 \times V_{fl} + K_2 \quad (1)$$

and

$$P_{r,dBW} = K_1 \times V_{rl} + K_2 \quad (2)$$

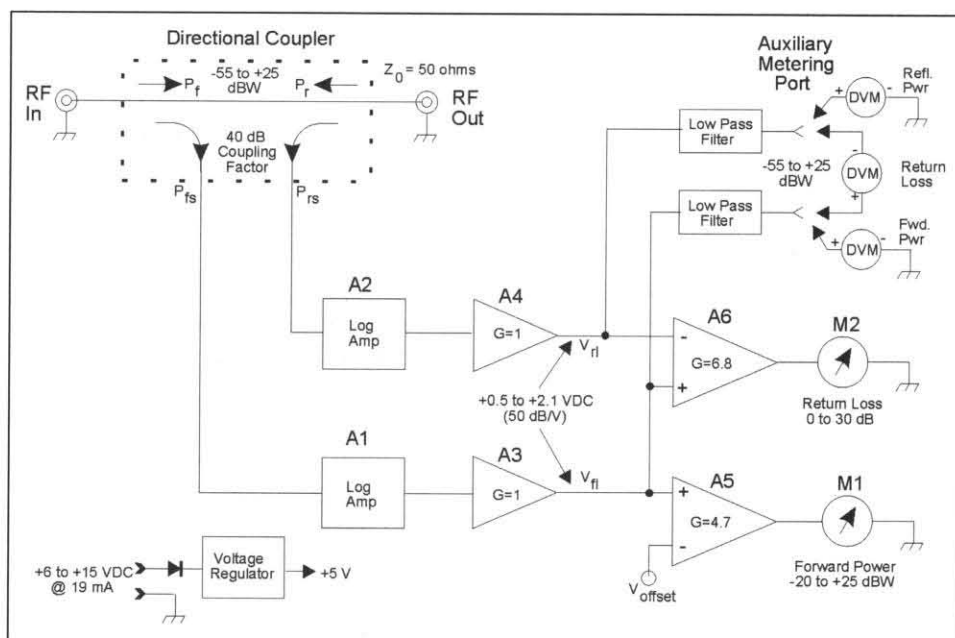

Figure 1—Block diagram of the HF in-line return loss and power meter.

Calibration is required to obtain near equality of like constants  $K_1$  and  $K_2$  in the forward and reflected paths. After calibration, we can measure DC voltages and relate them to mainline forward and reflected power, in dBW or watts, over the 80 dB range.

Instead of measuring SWR directly, we can simply measure return loss in dB, RL, by taking the difference of the log amp outputs [2]:

$$\begin{aligned} RL &= P_{f,dBW} - P_{r,dBW} \\ &= (V_{fl} - V_{rl}) \times K_1 \quad (3) \end{aligned}$$

In this design,  $K_1$  is set to a nominal value of 50 dB/V. The above difference can be taken externally using a single floating input digital voltmeter for enhanced precision or internally using the A6 amplifier, which drives the return loss meter, M2.

The DC forward voltage and an offset voltage are processed through the A5 amplifier which provides the needed gain and offset to drive the forward power meter, M1. The offset voltage allows the user to select the desired power range to be displayed on the forward power meter.

All circuits are powered by a single low dropout positive voltage regulator to facilitate battery operation. The combination of powering, the op amp input polarities and gains, and the ground referenced analog meters provides meter protection.

Meter disabling, used in some designs to eliminate spurious or erratic readings when RF is not present, is also not needed here since the two log amps typically have nearly identical outputs without RF.

Analog meters are used for the primary display to facilitate adjustment of antenna tuners. Watching a needle swing to a peak or a null rather than reading digits on a DVM is usually easier for most users. Both meters are calibrated using linear dB scales for both return loss and forward power. Each swings upward with increased return loss and forward power.

While the analog meters are sufficient for many uses, the auxiliary metering port and a DVM can be used to more accurately measure the entire  $-55$  dBW to  $+25$  dBW ( $3 \mu\text{W}$  to 320 W) range for both forward and reflected power as well as return loss. Since numerical values for  $K_1$  and  $K_2$  can be determined after calibration, it is a simple matter to obtain accurate values for forward power, reflected power, and return

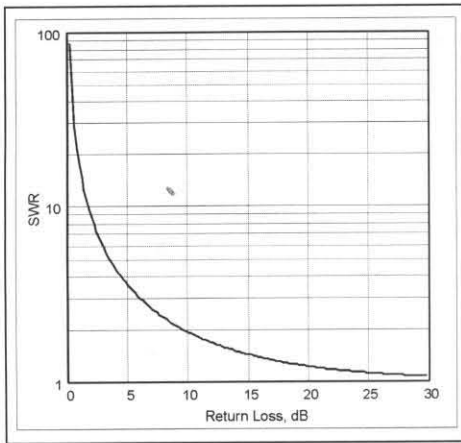

Figure 2—Graph for converting return loss to SWR.

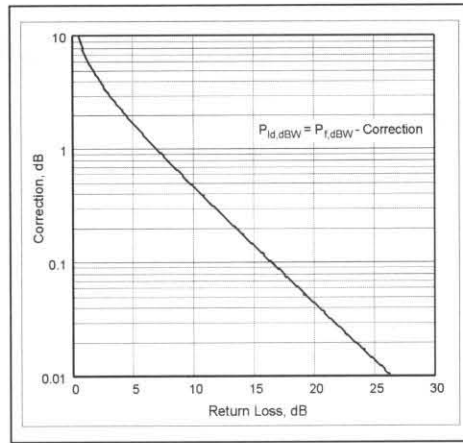

Figure 3—Load power correction using measured forward power and return loss.

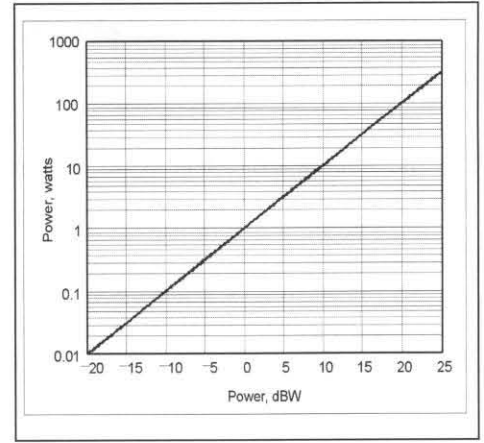

Figure 4—Graph for converting power in dBW to watts.

loss using the measured DVM voltages and a calculator. Figure 1 shows the DVM connections required to directly measure forward power, reflected power, and return loss.

### Return Loss and SWR

The key features of Figure 1 are simplicity, accuracy, wide power range, and independence of measured return loss from forward power. This last feature is particularly striking when transmitting SSB where the forward power meter continually fluctuates and the return loss meter barely moves.

Most radio amateurs use meters that measure the voltage standing wave ratio, VSWR, which is generally simply called SWR. This instrument breaks away from that trend by measuring and displaying return loss in place of SWR. Figure 2 provides a conversion between return loss and SWR, using this instrument's 0 to 30 dB return loss scale.

Most amateurs will want return loss higher than 10 dB (1.9:1 SWR) in normal operation and higher than 20 dB (1.2:1 SWR) in some cases. As you can see, you adjust your antenna tuner for a return loss peak rather than a SWR null. But that will take maybe 5 minutes to get used to.

The rationale for limiting maximum displayed return loss to 30 dB (1.07:1 SWR) is twofold. The first is to minimize the forward power required to adjust an antenna tuner and still be able to measure maximum displayed return loss, in this case 30 dB. Using -55 dBW for the minimum measurable reflected power and 30 dB return loss results in a forward power

of -25 dBW, or equivalently, 3 mW. In actual practice, 1 mW of forward power has been routinely used since the log conformance does not deviate too abruptly at the low end.

The second reason for the 30 dB limit is that the error in measured return loss increases with return loss, as will be seen later. This limit represents a trade-off between increasing measurement error and diminishing returns in efficiency.

A forward power range of 1 mW to over 300 watts, while maintaining good return loss accuracy, makes this instrument compatible with a wide variety of available RF sources.

### Forward Power vs. Load Power

This instrument measures forward power instead of load power. For high values of return loss, forward power can be used to approximate load power. Using the measured return loss and forward power, Figure 3 shows a correction factor in dB that can be subtracted from the measured forward power to get load power.

The error in using forward power for load power, without any correction, is less than 0.5 dB for return loss higher than 10 dB (1.9:1 SWR) and less than 0.05 dB for return loss higher than 20 dB (1.2:1 SWR). The added circuit complexity required to display load power instead of forward power is not warranted during normal operation. If needed, accuracy can be improved using either Figure 3 or the formulas in the sidebar.

This instrument displays forward power in dBW instead of watts. Figure 4 provides a conversion between the two.

Using power in dBW instead of watts is useful in that it more accurately conveys the impact of making power changes. For example, going from the typical transceiver output of +20 dBW (100 watts) to a QRP level of +7 dBW (5 watts) is a 13 dB decrease, or a little more than two S-units [3]. The difference seems smaller expressed that way and makes you want to give QRP a try, doesn't it?

### Directional Couplers

Several directional coupler and bridge circuits were studied for possible use in this instrument. The choices were narrowed to two circuits: the coupler used in the Tandem Match [4] and variations of the popular Bruene bridge [5]. The Tandem Match coupler is shown in Figure 5(A) and one variation of the Bruene bridge is shown in Figure 5(B).

The Tandem Match coupler has some nice features: simplicity, excellent directivity, scalable to different power levels, and 50 ohm load impedances on all ports. The Tandem Match coupler was built and tested.

While directivity [6] exceeds 40 dB on all HF amateur bands and coupling factor is flat to within  $\pm 0.35$  dB, it does have one disappointing characteristic for general HF use. Figure 6 shows the return loss measured at the input of the Tandem Match coupler with a 50 dB return loss termination at its output. The input return loss for the Tandem Match coupler is about 30 dB or better above 7 MHz, but steadily degrades to only 18 dB at 1.8 MHz, which is equivalent to an input SWR of 1.3:1.

So, while the Tandem Match coupler is

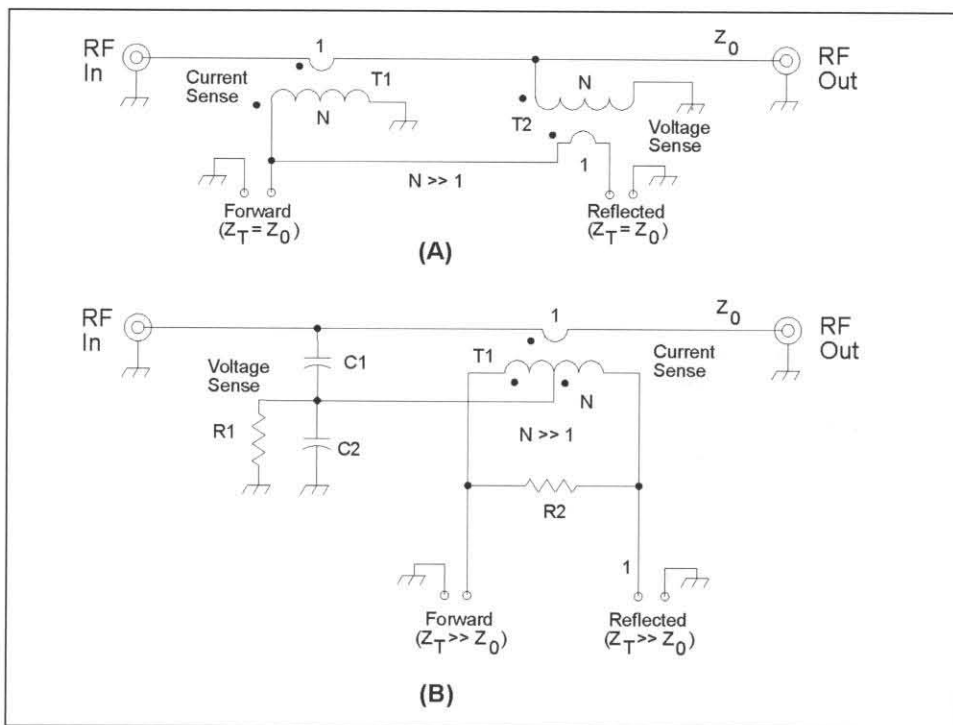

Figure 5—Directional couplers: (A) Tandem Match coupler, and (B) Bruene bridge (phase compensated).

capable of accurately sensing low SWR on the transmission line connected to its output, it does not do as well in presenting a low SWR load on the lower amateur bands to the transmitter. Surprisingly, no explicit mention has been previously made of this characteristic; perhaps, no one else has thought about measuring the SWR of the SWR meter!

While improving this characteristic through design changes was not exhaustively explored, it did appear that improving low frequency input return loss would likely result in reduced high frequency directivity [7].

The Bruene bridge, in various forms, has been used over the years in many homebrew and commercial in-line HF

SWR meters ranging from QRP to QRO capability. Input return loss is usually not a problem as long as the coupling factor in dB is high.

While there are obstacles to achieving good directivity, it can be done. Referring to Figure 5(B), the main obstacles to good directivity are: a) parasitic lead inductance associated with C2, b) high values for C2, c) excessive secondary wire length on T1, and d) impedance control in the bifilar secondary winding. The lead inductance and C2 result in a series resonance that progressively deteriorates bridge balance as the frequency is raised. Figure 7 shows the deterioration in 28 MHz directivity with increased parasitic lead inductance in an otherwise ideal Bruene bridge.

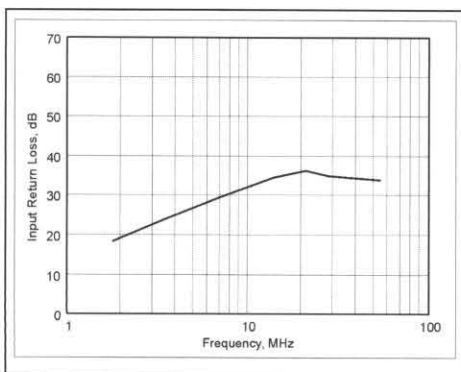

Figure 6—Measured Tandem Match coupler input return loss.

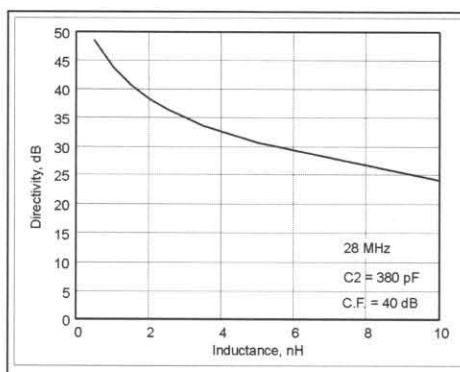

Figure 7—Bruene bridge directivity sensitivity to lead inductance.

The Bruene bridge used in this meter, including the log amps, was built and tested. Figure 8 shows the input return loss, directivity, and coupling factor. Some key characteristics are:

- input return loss exceeds 50 dB [8] for 1.8 - 30 MHz (41 dB at 54 MHz)
- directivity exceeds 40 dB for 1.8 - 30 MHz (33 dB at 54 MHz)
- the coupling factor is flat to within  $\pm 0.4$  dB for 1.8 - 54 MHz.

While the Bruene bridge is more complex, requires adjustment, and loses the 50 ohm termination feature when compared to the Tandem Match coupler, it was decided that the improved input return loss overcame those disadvantages.

### Circuit Description

The complete circuit is shown in Figure 9. Much of the circuit has been described in Measurement Overview and is supplemented here.

C1 provides the coarse bridge balance while C6 provides the fine adjustment. Four paralleled capacitors are used at C2 through C5 to provide low parasitic inductance. C2, C3, and C4 are chip capacitors that are mounted between the plates of C5. Refer to the next section for construction details.

The parallel combination of R1 and the log amp common mode input impedances extends the low frequency directivity of the Bruene bridge. It was necessary to keep T1 secondary inductance low and its total load resistance high to accommodate the relatively low common mode impedance of the log amps while maintaining high frequency directivity.

To accommodate the above characteristics and to maintain bridge directivity as

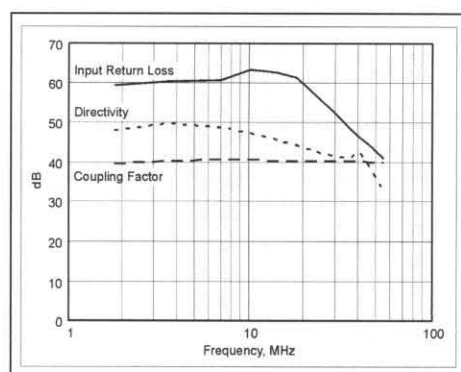

Figure 8—Measured Bruene bridge characteristics (including log amps).

high as possible, a modification to the Bruene bridge is made. The single resistor normally across the transformer secondary is split into three resistors, R2, R3, and R4. This provides reduced amplitude signals to the log amps and better impedance matching to the bifilar wound transformer secondary.

Each of the voltage and current senses has a nominal 46 dB attenuation. When the appropriate phases are summed for the forward signal, this amounts to a nominal 40 dB coupling factor. The difference provides the reflected signal. Ideally, the difference would be zero (infinite directivity in dB), but various imperfections limit the actual directivity. The differential inputs provided by the log amps are used to form the required sums and differences involving the capacitive voltage divider and the appropriate phases of the inductive current sense.

Pots R10 and R12 at the log amp outputs provide the adjustment of each gain to the nominal 50 dB/V. Pot R6 provides the offset adjustment to set the indicated reflected power equal to the indicated forward power when the actual return loss is 0 dB, an open or a short for example.

The U3A and U3B unity gain buffers are required to be nearly negative rail compatible since the log amp outputs range from about 0.17 V to 2.1 V. The auxiliary external metering port at J3 is filtered to protect the unity gain buffers against inadvertent shorts and reduce the effects of external noise. The log amp data sheet recommends that care be taken to keep unwanted signal sources away from these highly sensitive and wideband amplifiers.

The log forward and reflected voltages are subtracted in U3C which drives the reflected power meter M2. Since there is a large common mode voltage at the U3C input when the forward power is high, the R17 - R20 gain setting resistors are 1% tolerance to reduce the error caused by common mode response.

By providing the forward power signal to the positive input of U3C and the reflected to the negative input, the output voltage at U3C is 0 V for 0 dB return loss and +4 V for 30 dB return loss. Pot R29 provides the full scale adjustment for indicated return loss on M2.

Return loss meter protection is provided in two ways. Reverse meter swing is not possible since the U3C op amp output can

not go below ground and the minus lead of the meter is connected to ground. Forward swing meter protection is provided by the U3C op amp maximum output limit of +5V. That level is equivalent to a 25% over-current through the meter and has not been a problem.

Disabling the return loss meter in the absence of RF is not required since both log amps produce approximately 0.17 V output. This is displayed as 0 dB, within about 0.5 dB, or essentially no meter deflection.

The log forward voltage and an offset voltage are subtracted in U3D. Pot R26 provides control of the offset voltage which sets the minimum power point on the forward meter scale. Forward power meter protection is provided by essentially the same means as used on the return loss meter. Pot R31 provides the full scale adjustment for indicated forward power on meter M1.

The voltage regulator used at U4 is a low drop-out type (about 250 mV) to maximize utilization of battery capacity. When combined with the reverse input protection provided by the D1 Schottky diode, the minimum required DC input is +5.7 V and the current is 19 mA which is suitable for 9 V battery usage. At the high end, +15.5V should not be exceeded.

### Construction

The entire circuit, except for C17, C19, J3, J4, C22, C25, M1, and M2, is constructed on double-sided copper clad board. The board dimensions were selected to permit mounting inside an MFJ-948 antenna tuner. While this board was tailored to the MFJ-948 environment, it should be usable as is, or with minor modification, in many environments that have a pair of SO-239 connectors.

Figure 10 shows three pictorial views to assist in locating key components. The board is fastened to the shield side of the Transmitter SO-239 connector on the MFJ-948 using two shortened ring terminals soldered to one of the board's copper planes. The original pop rivets securing the SO-239 connectors were removed and replaced with 4-40 screws, nuts, and lock-washers.

The bridge components are split between both sides of the board for shielding. T1 and part of C1 are mounted on the side of the board that accesses the center

conductor of the SO-239 connector. The metal plane on this side of the board is dedicated exclusively to ground. The primary winding of T1 uses the center conductor of a short section of RG-8X. The shield of this coax is grounded at one end only using a small piece of tin sheet stock that also supports the coax and T1. The coax jacket is left on where it passes through the core. The fit is quite tight and will require a careful flattening of the secondary turns against the core and possibly either sanding down the jacket or softening the jacket with a heat gun just prior to sliding the core over the coax jacket. The jacket could also be replaced with teflon or fiberglass tape.

The plates of C5 use the above solid ground plane on one side and a section of the metal plane on the other side. The remainder of the split plane, except for some small pot mounting pads, is dedicated to ground and is connected to the plane on the other side using six jumpers equally spaced along the split plane dividing line. The relatively thin 0.031" board was used to maximize the capacitance available for C5 in a given board area. Standard 0.062" board can also be used with possibly some loss of high frequency directivity. C1 is formed with a short section of RG-8X coax with the outer jacket removed. The center conductor is attached to T1 in a fashion that permits the coarse bridge balance by sliding the center conductor in and out of the coax. The coax shield is soldered to C5 where it passes through C5. The ground plane around C1 on the other side is cleared to avoid shorting. Three holes are drilled through C5 for C2, C3, and C4, which are chip capacitors that just fit between the planes of C5. The chip capacitors are carefully centered between the planes to avoid shorting C5.

Two holes are drilled through C5 for two of the three T1 secondary leads. The center-tap for T1 is soldered to the ground plane. R2 - R4 and the remaining board components are located on the opposite side of the board.

Just a few general comments about the style of dead bug (ugly) construction used here are in order.

First, the DIP module ground lead(s) are carefully bent and trimmed in length to be even with the top surface of the module and as close as possible to the body of the module without snapping off the leads. The remaining leads are cut at the point

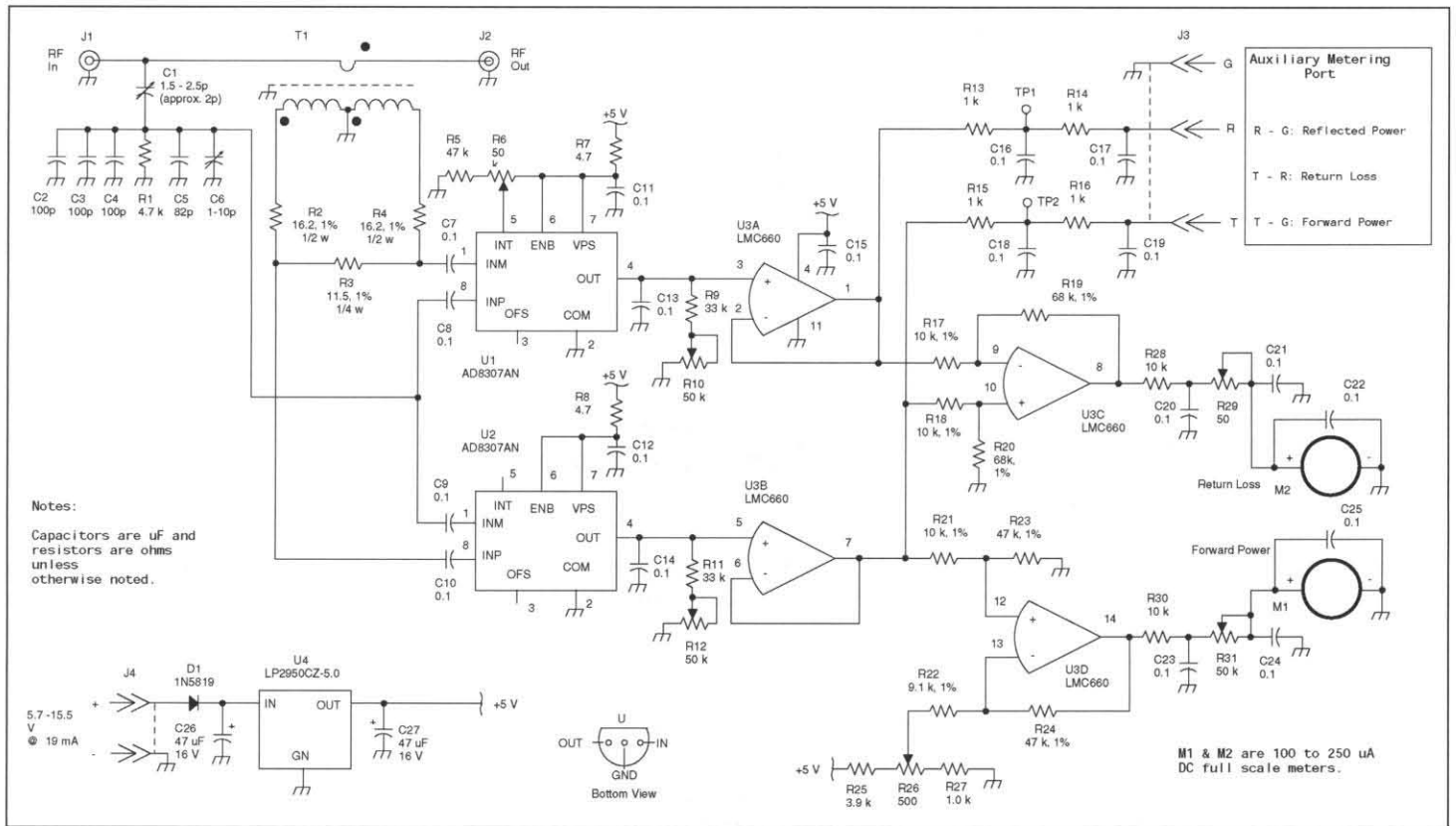

- C1 – 25 mm RG-8X  
 C2, C3, C4 – 100 pF, NPO, 50 WVDC, Size 0603, ceramic chip capacitors (Digi-Key PCC101ACVCT-ND)  
 C5 – 40 mm x 33 mm isolated area of copper plane on one side of 0.031 inch thick double sided copper clad board. The opposite side is ground.  
 C6 – approx. 1-10 pF trimmer. (Mouser 24AA071 or Digi-Key SG-1034ND))  
 C26, C27 – 47 mF, 16 V, electrolytic (Digi-Key P969-ND or Mouser 140-HTRL16V47)  
 D1 – 1N5819 Schottky diode (Mouser 583-1N5819 or Digi-Key 1N5819GICT-ND)  
 J1, J2 – SO-239 chassis mount connector  
 J3 – 1/8" (3.5 mm) panel mount 3 cond. phone jack (RadioShack 274-249)  
 J4 – 3/32" (2.5 mm) panel mount 2 cond. phone jack (RadioShack 274-292 or 274-247)  
 M1, M2 – 100 to 250 mA full scale meter(s)  
 R2, R4 – 1/2 W, 1% metal film (Mouser 273-16.2)  
 R3 – 1/4 W, 1% metal film (Mouser 271-11.5)  
 R6, R10, R11, R29, R31 – 50 kohm, cermet trimmer pot (Mouser 72-T70XW-50K)  
 R17 to R24 – 1/8 W, 1% metal film (Mouser 278-Value, for example, 278-10K)  
 R26 – 500 ohm cermet trimmer pot (Mouser 72-T70XW-500)  
 T1 – Secondary is 11 bifilar wound turns of #22 AWG enameled wire, tightly and uniformly wound around a T50-3 core. Primary is 33 mm of RG-8X with shield grounded at J1 end only.  
 U1, U2 – Analog Devices AD8307AN (Allied Electronics 630-8006, Newark 83F3404, or Future Active AD8307AN)  
 U3 – National LMC660CN (Digi-Key LMC660CN-ND)  
 U4 – National LP2950CZ-5.0 (Digi-Key LP2950CZ-5.0-ND)
- Unless otherwise specified, resistors are 1/8 W, 5% tolerance carbon composition or film units. All 0.1 mF capacitors are 50 volt axial ceramic (Digi-Key 1210PHCT-ND or Mouser 147-72-104). Equivalent parts can be substituted.

**Figure 9—Schematic and parts list for the HF in-line return loss and power meter.**

where the lead steps down in width. The modules are positioned with the top of the module placed against the board surface and soldered to the board ground plane.

Decoupling capacitors are used on all component power leads and soldered directly from the module or component lead to the ground plane as close as possible. All other decoupling capacitors or components, grounded at one lead, are mounted in the same way. The remaining

components are soldered point to point and directly to module leads wherever possible.

Generally, only one layer of components above the modules is used, but two layers are used when components can cross without danger of shorting. Insulated wire is attached to a component which has been secured directly to a module at only one end. All insulated wiring is dressed against the ground plane.

Trimming the module leads and keeping the components and wiring around module lead height helps to minimize stray coupling, unit to unit variability, and inadvertent shorting. In some cases, isolated pads to secure larger or adjustable components are carved out of the board plane using an Exacto knife. Alternatively, hot melt glue can also be used to secure these components to the board without pads.

Board planes are never carved up near

high frequency components or components that require shielding. Op amps, while not particularly high frequency components, are likely to rectify RF and generate offset errors. So, the board plane is left intact around the op. amp module as well as the log amps.

Dead bug construction, as used here, allows the two board planes to shield the sensitive amplifiers from the high RF environment near the primary of T1 on the other side. However, there's no doubt that dead bug construction is ugly to many people, has virtually zero manufacturability, and needs greater care in handling.

The usual pin in hole and printed wire construction with components on the same side of the board as T1 may be used but may require additional measures for shielding.

Printed wiring should be restricted to the non-module side of the board to maintain the module side copper as a solid ground plane, except for the smallest possible clearances around component lead pads. Placing a grounded shield over the modules and mounting the circuit board on a metal box that surrounds the printed wiring may also be needed to provide RF shielding.

### Meter Scales

The MFJ-948 antenna tuner uses a single meter enclosure with dual movements. A compatible overlay for the face of this meter is shown in Figure 11 and can be used as a basis for other meters.

The forward power scale ranges from -20 dBW to +26 dBW. Note that -20 dBW point is slightly above the forward power needle resting point. This scale, which is a fraction of the measurable power range, was chosen to improve accuracy over the anticipated range of transmitter output power levels. This range can be changed, but may require different values for R25 and R27.

The return loss scale ranges from 0 to 30 dB. The 0 dB point corresponds to its needle resting point.

### Calibration

Referring to Figure 9 for connections, the calibration procedure is described as follows:

1. With power off, adjust the meter needle resting points as shown in Figure 11.

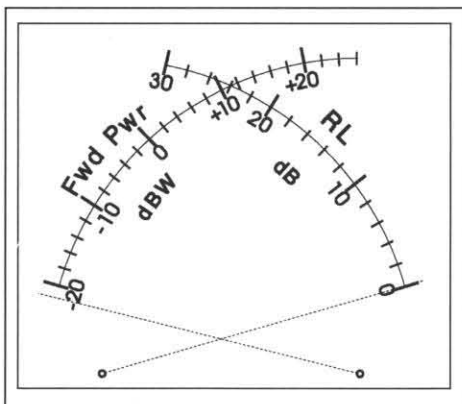

Figure 11—Dual meter movement scales, shown in the power off position.

2. Connect a DC power source to J4. Connect a low power 7 MHz RF source (about 10 mW) to J1. Connect a high return loss 50 ohm termination [9] to J2. Set C6 for the center of its range. Monitor return loss at J3 with a voltmeter and adjust C1 for maximum return loss as close as possible. Then adjust C6 for maximum return loss. If desired, change to 28 MHz and adjust the spacing between the wires in the bifilar pair on T1 to improve high frequency return loss.
3. Use the set-up from Step 2 except monitor forward power at J3 using a DVM for best accuracy. Adjust R12 for 50 dBW/V using two known power levels. To determine the actual dB/V calibration factor, measure the forward voltage at each of the two power levels and take the difference; also calculate the difference in power levels in dBW. Then divide the power difference by the voltage difference and compare to 50 dB/V.
4. Use the set-up from Step 3 but reverse the connections to J1 and J2. While monitoring reflected power at J3, adjust R10 for 50 dB/V using the two known powers and the calculation procedure from Step 3. Precisely hitting 50.00 dB/V for Steps 3 and 4 is not required as long as they match each other reasonably well.
5. Reconnect the signal source to J1 and leave J2 open. Make sure your RF source is capable of withstanding high SWR. While monitoring return loss at J3, adjust R6 for zero volts. For improved accuracy, alternate between a short and an open at J2 and balance the measured values around zero volts.

6. Cycle through Steps 4 and 5 if needed.
7. Reconnect the 50 ohm termination to J2. Connect a known power RF source to J1 around -20 dBW (10 mW). Adjust R26 to set the meter to the appropriate mark on the scale.
8. Connect a known power source near +20 dBW (100 watts) to J1 and a suitably rated 50 ohm dummy load to J2. Adjust R31 to set the meter to the appropriate mark on the scale.
9. Cycle through Steps 7 and 8 if needed.
10. Connect a low power RF source around 10 mW that can withstand high SWR to J1. Leave J2 open. Verify that the return loss meter reads zero within about 0.5 dB.
11. Use the same RF source at J1 from Step 10 and connect a termination with known return loss around 20 dB [10] to J2. Adjust R29 to set the meter to the appropriate mark on the scale.

Once calibration is complete, four numerical values can be calculated for K1 and K2 in equations (1) and (2) if the auxiliary metering port is to be used. This is done using the measured data from Step 3 and Step 4 after Step 6 is done. The two values for K1 should be close to each other and can be averaged for most purposes. Due to log amp differences, the two values for K2 may be different and both should be used in that case. All four values can be used for best accuracy. For reference, with K1 equal to 50.3 dB/V, K2 is typically about -79 dBW.

To provide the two known forward powers required in the calibration procedure, I modified a Heath Antenna to include a 40 dB attenuator with 50 ohm input and output impedances and a linearized diode detector, similar to that used in the Tandem Match. The detector monitors RF voltage on the low power attenuator output.

With this modified Antenna, either the +20 dBW (100 watts) input power can be used directly or the attenuator output at -20 dBW (10 mW) can be used. The 100 watt input is verified using the diode detector.

The entire calibration procedure can be performed at these two power levels using a 100 watt transmitter, a high power attenuator such as the modified Antenna, 50 and 60 ohm low power loads, and a DVM.

In general, a 5 to 100 watt transmitter,



a signal generator, a calibrated attenuator, another power or wattmeter, and a dummy load are possible tools that can be used to establish two known forward powers. The calibration procedure can be modified as needed to accommodate available equipment.

### Accuracy

In addition to the measured characteristics shown in Figure 8, estimates of forward power and return loss accuracy were also made using the auxiliary metering port.

Forward power accuracy was evaluated using 10 - 300 watts to the modified Cantenna at 7 MHz. Over this power range, the power measured by this meter was within 0.4 dB of that measured by the linearized RF detector on the Cantenna.

Return loss accuracy was evaluated using a set of metal film resistor terminations, each coaxially mounted in a male BNC connector. The set provides nominal 0 to 30 dB return losses in 5 dB increments. Two resistor values, one greater than 50 ohms and the other less than 50 ohms, will have the same return loss; both values were used here. The actual return loss for each termination was measured using the 4 wire DC resistance technique. Figure 12 shows the maximum deviation in dB of the measured return loss vs. the actual return loss. Typical accuracy is better than 0.5 dB rising to 1.2 dB at 28.5 MHz and 30 dB return loss.

### Operation

In normal operation, this meter would be inserted in a 50 ohm coaxial line between the transmitter and either an antenna or an antenna tuner. In either case, as little as 1 mW of RF (-30 dBW) can be used with this meter and still accurately measure up to 30 dB return loss. Few, if any, in-line wattmeters accurately measure 1  $\mu$ W of reflected power (-60 dBW). As a result, the level of on-the-air QRM can be reduced.

Adjustment of antenna tuners can be done at any power level exceeding 1 mW, but preferably as close to that level as the transmitter will allow. Simply adjust the controls to obtain either peak return loss or return loss greater than some desired value such as 10 dB (1.9:1 SWR).

After the adjustment is complete, normal intermittent service for forward power

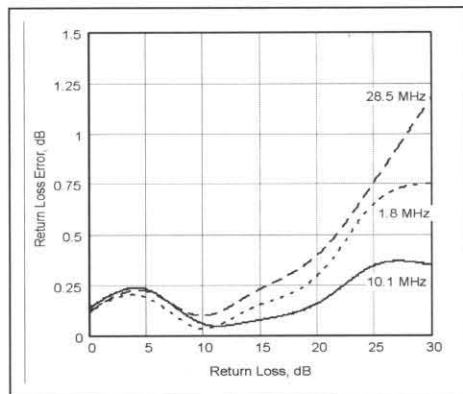

Figure 12—Measured return loss error.

up to 300 watts can be used if the return loss is 10 dB or higher. Limited testing at 500 watts with 20 dB return loss was performed without problems.

There should be little change in the displayed return loss, from 1 mW to 300 watts of forward power, as a result of instrumentation error. Log amp tracking, common mode rejection, and residual calibration errors will typically limit the variation to under 1 dB. Heating of antenna tuner components, particularly the inductor, or the resistor in a dummy load can cause perceptible changes for high return losses that may have previously gone un-noticed.

Lower than 10 dB return loss will require a reduction in maximum forward power. For example, 6 dB return loss (3.0:1 SWR) will require that the intermittent service forward power be limited to 230 watts (+23.6 dBW), which is equivalent to about 170 watts of load power.

Depending on the proximity of local transmitters, such as TV, radio, pagers, or other amateurs, there is another possible source of apparent return loss variation. Since the log amps are wideband and very sensitive, they will respond to strong local sources of RF at their inputs. At one time, a neighboring amateur would induce about a -45 dBW signal on my antenna, which is sufficient to affect measured return loss for forward powers less than -15 dBW (32 mW). The solution is to either raise power or tune up when the interference is gone.

The wide frequency and power range of this instrument make it suitable for other general test purposes. For example, gain/loss and return loss measurements of a wide variety of 50 ohm devices, such as filters, cables, amplifiers, and attenuators, can be performed. While the 1 mW mini-

imum forward power required for 30 dB return loss may be too high for some amplifiers, it can be reduced by 25 dB if only gain measurements are performed. Return losses lower than 20 dB can be measured with 100  $\mu$ W.

50 ohm cable loss can be measured in two ways. The first is to use the fact that the cable loss in dB, at any frequency, is one-half of the return loss in dB measured when the far end of the cable is either open or shorted. Connect one end of the cable to J2 and an RF source to J1 and divide the measured return loss by two. The advantage of this method is access is required to only one end of the cable as long as the other end is open or shorted.

The other way of measuring cable loss, which is typically more accurate, is the insertion loss method. Connect an RF source to J1 and attach a 50 ohm load to J2. Note the forward power in dBW on either the analog meter or as calculated using a DVM attached to the auxiliary metering port. Then insert the cable to be tested between the RF source and J1 and again note the forward power in dBW. The difference between the two measured powers is the cable loss in dB.

If a DVM is used for either return loss or differences in dBW forward power, the calculation can be simplified by first subtracting the two measured voltages and then multiplying by the nominal 50 dB/V log amp gain (or the actual value established during calibration) to obtain the cable loss in dB.

Measurements of most other devices can be done using one or both of the above techniques. The auxiliary metering port and a DVM will prove useful in extending measurement range and accuracy, particularly in cases, such as amplifiers, where input power must be limited to avoid gain compression.

### Modifications

The 500 MHz frequency range of the log amp makes VHF and UHF possible by simply changing the directional coupler. While a detailed design has not been done, some preliminary modeling indicates that a single coupled stripline design could be used for both 2 meters and 70 cm. The log amp frequency rolloff should roughly compensate for the increased stripline coupling factor as the frequency is raised. Additional frequency shaping is also possi-

ble.

The following changes can be made either singly or in combination:

- If two analog meters are not available, then one meter and a SPDT switch can be substituted.
- If the auxiliary metering port is not needed, then R14, R16, C17, C19, and J3 can be eliminated. Calibration is then performed using TP1 and TP2.
- If high accuracy is not needed, then R10, R12, R5, and R6 can be eliminated. Specified log amp tolerances may be adequate for many users. R9 and R11 would be changed to 51 k and grounded at one end. Nearest 5% values for R17 - R24 can also be substituted.
- If forward power measurement is not needed, then U3D, R21-R31, C23, C24, and M1 can be eliminated.
- Substituting the SOIC AD8310 for the AD8307 would eliminate the unity gain buffers since there are buffers in the

AD8310. This would also allow use of the 8 pin LMC662 in place of the LMC660, saving more space. The log amp gain and offset setting resistors would also be changed.

- C2-C5 can be combined or changed to pin in hole leaded components with loss of directivity. For leaded components, use 20 nH/inch, applied to the component lead length plus the lead spacing at the component body, and Figure 7 as a guide to estimate directivity. Paralleling equal capacitors also roughly divides the lead inductance for one capacitor by the number of capacitors to obtain the inductance used in Figure 7.
- Other full scale meters, both below 100  $\mu\text{A}$  and above 250  $\mu\text{A}$  up to about 1 mA, can be used by changing R28 and R30. Changing the maximum power either higher or lower is possible. Reducing the maximum power to 10 watts, for example, would simply require changing R25 to 5.1 k and a meter scale change. The

forward power scale would be changed to range from -30 dBW (1 mW) to +10 dBW (10 watts). Increasing the maximum power would require changes to the bridge, R25, and the forward meter scale. These changes are left to the interested reader [11].

### Acknowledgements

This project would not have been possible without the efforts of Barrie Gilbert who spearheads the log amp activity at Analog Devices. I also want to thank Bob Stedman, K9PPW, Bill Carver, W7AAZ, Bill Craddock, WB4NHC, Dale Parfitt, W4OP, and Steven Weber, KD1JV, for many interesting and helpful e-mail exchanges and conversations.

### Notes

1. The data sheet for the AD8307, Analog Devices, Norwood, MA, is available from their website at <http://www.analog.com>. It contains a good overview of log amp theory

## Power, SWR, and Return Loss

The units dBm and dBW are measures of RF power in dB with respect to references of one milliwatt and one watt respectively. Conversions from watts to dBW and dBm are (All logs used here are base 10):

$$P_{\text{dBW}} = 10 \times \log(P_{\text{W}})$$

$$P_{\text{dBm}} = P_{\text{dBW}} + 30$$

Return loss in dB, RL, is related to the magnitude of the complex voltage reflection coefficient,  $|\rho|$ , by:

$$RL = -20 \times \log |\rho|$$

Voltage standing wave ratio, VSWR, is related to  $|\rho|$  by:

$$VSWR = \frac{1 + |\rho|}{1 - |\rho|}$$

and can be calculated from return loss using:

$$|\rho| = 10^{-RL/20}$$

To obtain return loss in terms of forward and reflected power, we start with:

$$|\rho| = \frac{|V_r|}{|V_f|}$$

and some logarithm relationships to obtain:

$$RL = 20 \times \log |V_r| - 20 \times \log |V_f|$$

And, since

$$P_{\text{W}} = \frac{V^2}{Z_0}$$

for each of the forward and the reflected voltages, some more algebra yields:

$$RL = P_{\text{f,dBW}} - P_{\text{r,dBW}}$$

Load power can be calculated using the measured forward power and return loss. Convert forward power in dBW to watts using:

$$P_{\text{f,W}} = 10^{P_{\text{f,dBW}}/10}$$

Reflected power in dBW is calculated from:

$$P_{\text{r,dBW}} = P_{\text{f,dBW}} - RL$$

Reflected power is converted to watts using:

$$P_{\text{r,W}} = 10^{P_{\text{r,dBW}}/10}$$

Load power is determined from forward and reflected power, all in watts, by:

$$P_{\text{ld,W}} = P_{\text{f,W}} - P_{\text{r,W}}$$

as well as general application information.

2. The technique used here to measure return loss is not new. See Virgil G. Leenerts, WØINK, "Automatic VSWR and power meter," *ham radio*, May 1980, pp 34-43.
3. "S-units" are neither universally defined nor adhered to. 6 dB per S-unit is used here.
4. John Grebenkemper, KA3BLO, "The Tandem Match—An Accurate Directional Wattmeter," *QST*, Jan 1987, pp 18-26. The Tandem Match also appears in various editions of *The ARRL Handbook* and the *ARRL Antenna Book*.
5. See the *ARRL Antenna Book*, 18th Edition, Figures 4(E) and 4(F), p 27-4. The difference between Figure 4(F) and the Bruene bridge, as shown in Figure 4(E), is the addition of R1 which improves the low frequency directivity of the Bruene bridge.
6. For a detailed treatment of directivity and other related concepts, see *Network Analyzer Basics*, available from Agilent Technologies (formerly H-P) at [http://dragon11.cos.agilent.com/data/downloads/eng/tmo/techinfo/pdf/comptest\\_nabasics.pdf](http://dragon11.cos.agilent.com/data/downloads/eng/tmo/techinfo/pdf/comptest_nabasics.pdf)
7. The degraded low frequency return loss of the Tandem Match coupler is caused by the inductance of the voltage sense transformer which shunts the mainline. Since the design already uses a high permeability core suitable for HF use, increasing the shunt inductance will probably involve added wire length which will degrade high frequency directivity. The shunt inductance also increases an error, called source match error, that can be as high as ±1.1 dB for 1.8 MHz return losses near 0 dB.
8. Coupler directivity accuracy depends on the quality of the 50 ohm load used for the measurement. Input return loss accuracy depends on the 50 ohm load as well plus the directivity of the test bridge used.

While the accuracy is not traceable to NIST (preferable but expensive), the combination of the 50 ohm load described below and a carefully constructed type of Wheatstone bridge exceeds 50 dB measured directivity for 1.8 - 54 MHz. The DC resistance of the 50- load was measured using the 4 wire technique (see p 26.7 of the 1998 *ARRL Handbook*). This Wheatstone bridge is constructed with 49.9 ohm resistors for the three internal bridge arms, a single differential input AD8307 log amp for the detector, and a 52.3 ohm resistor across the log amp input. All resistors are 1%, 1/4 watt, metal film resistors. The differential input of the log amp eliminates the transformer, usually present to accommodate unbalanced detectors. Eliminating the transformer greatly improves directivity. To achieve a good open/short ratio with this bridge, a good 50 ohm generator impedance must also be maintained.

9. A low power, high return loss, 50 ohm termination can be built using a 49.9 ohm, 1%, 1/2 watt, metal film resistor which is coaxially mounted in a modified PL-259 connector. The resistor leads are cut as short as possible. The main body of the connector is cut off or ground down to just back of the threads. A small disk made from sheet tin stock, with a hole in the center, is soldered along its perimeter to the back of the connector and to the protruding resistor lead. A higher test power will require a suitably higher power rated 50 ohm termination or dummy load.
10. A 60.4 ohm, 1%, 1/2 watt, metal film resistor mounted in a PL-259 connector in the same fashion as above will provide 20.5 dB return loss, accurate to ±0.5 dB. Various other precision resistors can be mounted in similar fashion and used to verify accuracy at other points on the

return loss scale if desired. Four wire DC resistance measurements can be used to reduce the error due to resistor tolerance and soldering.

11. Referring to Figure 5B, the phase compensated Bruene bridge design equations are provided as a guide:

Bridge balance:

$$\frac{C1}{C1+C2} = \frac{R3'}{2 \times Z_0 \times N}$$

where R3' is the parallel combination of R3 and 2.2 k (2 times the log amp differential input impedance), Z<sub>0</sub> is the line characteristic impedance, normally 50 ohms, and N is the total secondary to primary turns ratio, or 22 in the current design.

The coupling factor in dB is:

$$CF = 20 \times \log[(Z_0 \times N)/R3']$$

The phase compensation resistor, R1, is calculated from R1', which is the parallel combination of R1 and 510 ohms (the combined log amp common mode input impedance), using:

$$R1' = \frac{Ls}{(R2 + R3' + R4) \times (C1 + C2)}$$

where L<sub>s</sub> is the secondary inductance. Power dissipation in R2, R3, and R4 is calculated using the resistor values and the maximum transformer secondary rms current, I<sub>s,max</sub>:

$$I_{s, \max} = \frac{1}{N} \times \frac{P_{ld, \max} \times SWR_{\max}}{Z_0}$$

where SWR<sub>max</sub> is the maximum SWR that can be present simultaneously with the maximum load power in watts, P<sub>ld,max</sub>. ●●

*Mark Your Calendars for these QRP Contests:*

*Running of the Bulls  
November 2-4, 2002*

*Holiday Spirits Homebrew Sprint  
December 1, 2002*

*Topband CW & SSB Sprint  
December 4-5, 2002*

# Review: Palm Radio Mini-Paddle and Code Cube

Richard Arnold—AF8X

af8x@comcast.net

It was in October or November of 2000, when I first saw the Palm Mini-Paddle on the Internet (<http://www.palm-radio.de/>). I knew immediately I had to have one. I emailed Hannes Hiller in Ulm, Germany, and asked for ordering instructions. He informed me that they were not yet in production, and I would have to wait until they were ready to ship. The pictures and drawings on the Internet were only a "teaser" to see if there was any interest in the paddle. I informed Hannes that at my age I didn't have the luxury of waiting for anything, I wanted it now! He graciously agreed to send me the first one shipped to the U. S., and in a few weeks a package arrived containing Mini-Paddle, serial number 005.

The quality was immediately apparent, and I was pleased to find that the adjustments would satisfy the most critical hams. Unlike some others on market, this paddle is not just a couple of pieces of springy metal, but a fully adjustable precision device comparable to many of the larger, high-priced paddles. Adjustments include spring tension, contact spacing, and hard or soft paddle stop. I personally like the feel of the soft stop.

Much of my operation is portable, and what really sold me on the Mini-Paddle was its retractable mechanism and small size (1x1x3 inches). The paddles fully retract into the powder coated, extruded aluminum housing, completely protecting them from damage while transporting.

The base or "Quick Mount" for the paddle comes in two versions, the magnetic, which contains two very strong magnets, and the standard, which can be fastened by screws or an adhesive. The paddle housing is easily snapped in and out of the quick mount base, so I fastened separate bases to three of my rigs and found it easy to transfer the paddle to any of the three. Figure 1 shows the paddle mounted on the base and retracted into its case.

With the Dayton Hamfest approaching, I made arrangements via email to meet Hannes and purchase an additional paddle to be attached to a bracket on my bicycle. When we met, we quickly bonded and became friends. Later that evening, at the vendors night get together, he allowed me to give him a hand at his table where he

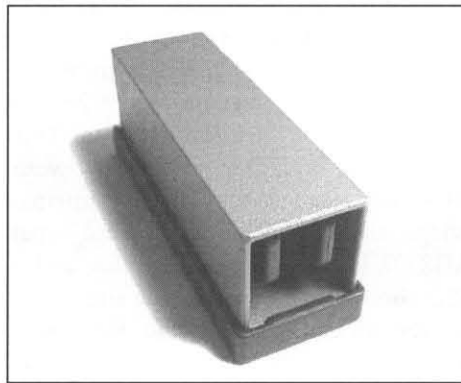

Figure 1—Mini-Paddle mounted on its base and retracted into its case.

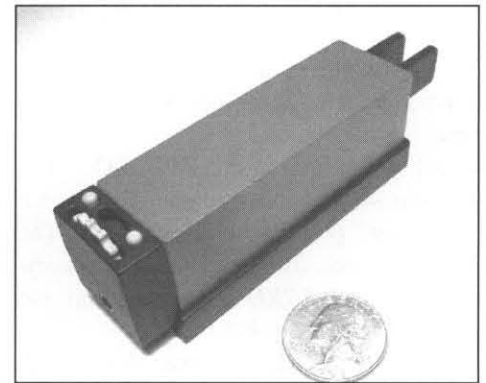

Figure 2—Code Cube mounted on the rear of the Mini-Paddle.

presented me with a Palm Radio tee shirt. Since that time, I have enjoyed using my Mini-Paddles and as yet have not found anything I don't like about them.

## The Code Cube

After the success of the Mini-Paddle, I asked Hannes if he had any other projects in mind for the next Dayton Hamfest. He said he had something in mind, but didn't elaborate.

Several months went by before I opened an email attachment from Hannes, and I was surprised to see pictures of a very small electronic keyer that plugs into the Mini-Paddle to become the smallest paddle/keyer combination in the world. This new keyer uses the Jackson Harbor Press PK3 chip, and is powered by a 3-volt lithium cell, which Palm Radio claims gives a useable lifespan of five years. One of the features I like is the speed control. A thumb wheel controls a programmable speed range so when you are operating, you don't have to look in a menu to

increase or decrease the code speed.

It is so nice to have a full featured keyer that that is almost stealthy, to accompany me on my field outings. The two 50-character memories and separate callsign and CQ generator allow for contest use as well. Figure 2 shows the Code Cube mounted on the rear of the mini-paddle.

The sidetone is rather wimpy, and as all my rigs have sidetone, I turned the Code Cube sidetone off. It's only use for me is for feedback during programming.

The Code Cube has an 18-page manual and a laminated short instruction card. I would recommend taking the laminated card along on any outing away from your shack, as there are a lot of features on this keyer that take some time to memorize.

For a take-along full function keyer, I rate this one at five stars.

The Mini-Paddle and Code Cube keyer can be ordered directly from Palm Radio via their web site ([www.palm-radio.de/](http://www.palm-radio.de/)) or in the U.S. from Morse Express ([www.morsex.com/palm/](http://www.morsex.com/palm/)). ●●

- Small sized twin paddle Made in Germany, to be used with the K2 and all other transceivers that have built-in keyer circuits.
- Paddles can be shoved inside, therefore perfectly protected by the case.
- Solid cabinet made of extruded aluminum, powder coated in the same color as the K2 Transceiver.
- Dimensions only 1 x 1 x 3 inches—perfect for travellers, backpackers and outdoor QRP fans!
- Lightweight: 1.72 ounces.

- Three separate adjustment screws allow individual adjusting possibilities:
  - Spring tension
  - Contact spacing
  - Paddle stop.
- According to personal preference, a hard or soft paddle stop is possible.
- Firmly seated with no play in the paddles.
- Gold-plated contacts guarantee longevity and reliability.
- Connecting cable for the K2/K1 and instructions supplied.

## Features of the Mini-Paddle.

# The Tuna Twin Too

## A Simple Receiver in the W1FB Style

Mike Boatright—KO4WX

ko4wx@mindspring.com

### R.I.P for D.I.Y.

*"But during recent years a trend has developed toward commercial gear with its status appeal, and the workshop activities of many have become the lesser part of amateur radio. While the 1-kW rigs keep the watt-hour meters recording at higher speed, the soldering irons grow colder and more corroded."* —Doug DeMaw (SK), W1CER in September, 1976 (later became W1FB).

As Jerry Hall, WØPWE, pointed out in the last *QRP Quarterly*, twenty-six years (to the month) after DeMaw bemoaned the apparent passing of "do it yourself" in amateur radio, *Scientific American* claimed that "The art of home-brewing one's own electronic equipment is pretty much a lost one."

Well, if you were among the over 200 in the ballroom of the Ramada Inn Dayton Mall last May 16th or at the NOGA QRP/Flying Pigs International build-a-thon that night, you'd know that home-brew is anything but dead.

### Take Heart

*"Workshop weekenders, take heart. Not all building projects are complex, time consuming and costly. The Tuna-Tin 2 is meant as a short-term, go-together-easy assembly for the ham with a yen to tinker."*

With those humble beginnings in mind, it is my pleasure to introduce you to the Tuna Twin Too. The inspiration of the Tuna Tin 2 sent this author to the Radio Shack store in search of parts just like it did DeMaw twenty-six years ago. While the parts counter is not quite what it was in 1976, it's still there and it is still possible to build a radio from almost only Radio Shack parts.

The Tuna Twin Too offered here comes pretty close. In fact, if you stocked a junk box according to the suggestions in my QRV? article in the April, 2002 *QRP Quarterly*, you can start building this little direct conversion receiver right away. The point is, while this is no K2 receiver (and thank you Wayne and Eric for such a wonderful radio!), it can be easily homebrewed,



and works quite handily as a companion to the famous Tuna Tin 2 transmitter.

In this project, I've used toroidal coils for inductors. This is primarily so that the circuit can be more easily reproduced. I'm sure it is quite possible that the inductors can be made by removing the windings of the 100  $\mu\text{H}$  choke (RS273-102C) that Radio Shack still sells and using the ferrite rods as cores. Some stores even stock inductor assortments—a gold mine for some experimenters!

Radio Shack also still sells a few NPO capacitors, although not in the exact values needed. However, with some experimentation, these could be used (for example, the value of C20 is 180 pF. Two 100 pF NPOs in parallel is only 10% off—probably close enough to still tune by adjusting the induc-

tor windings). When I built the first prototype, I used capacitors from the NorCal capacitor kit.

One thing that is different between 1976 and today—the world has become much more litigious. So before we go any further, let me say, I am not employed by Radio Shack, nor do I have any interest in them, nor their parent company, Tandy Corporation. My interest lies in the many, many hours that I've spent perusing their shelves (and trying to avoid cell phone salespeople!), and the desire to make it easy for the folks just getting started in home-brew construction to get started and HAVE FUN!

### Circuit Details

The circuit is a basic direct conversion receiver, consisting of a VFO, a mixer, some filters and some audio amplifiers.

The RF front-end is a bandpass filter, consisting of TR4, TR3 and C23, C24 and C25 and is a basic 40M bandpass filter. It is fairly wide, but does provide some basic selectivity and broadcast band rejection. It only has about 1 dB of insertion loss, however, so it is reasonably good for average listening.

The VFO uses two 1N4001 silicon diodes (D3, D4) as varactor diodes—that is, when you vary their reverse bias voltage (through VR2 and Q5), they act as variable capacitors. According to the 1N4001 datasheet, the nominal capacitance is 15 pF when reverse biased by 4 volts. Since the two capacitors are in series, the nominal capacitance is 7.5 pF, which varies as VR2

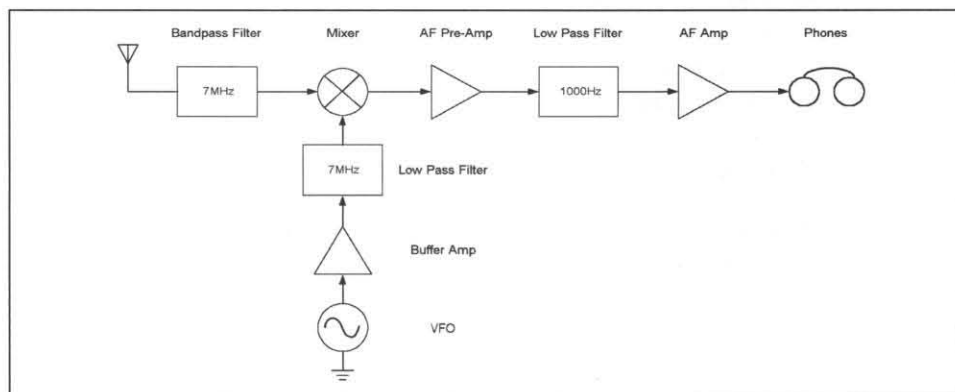

Figure 1—Block diagram of the Tuna Tin Too receiver.

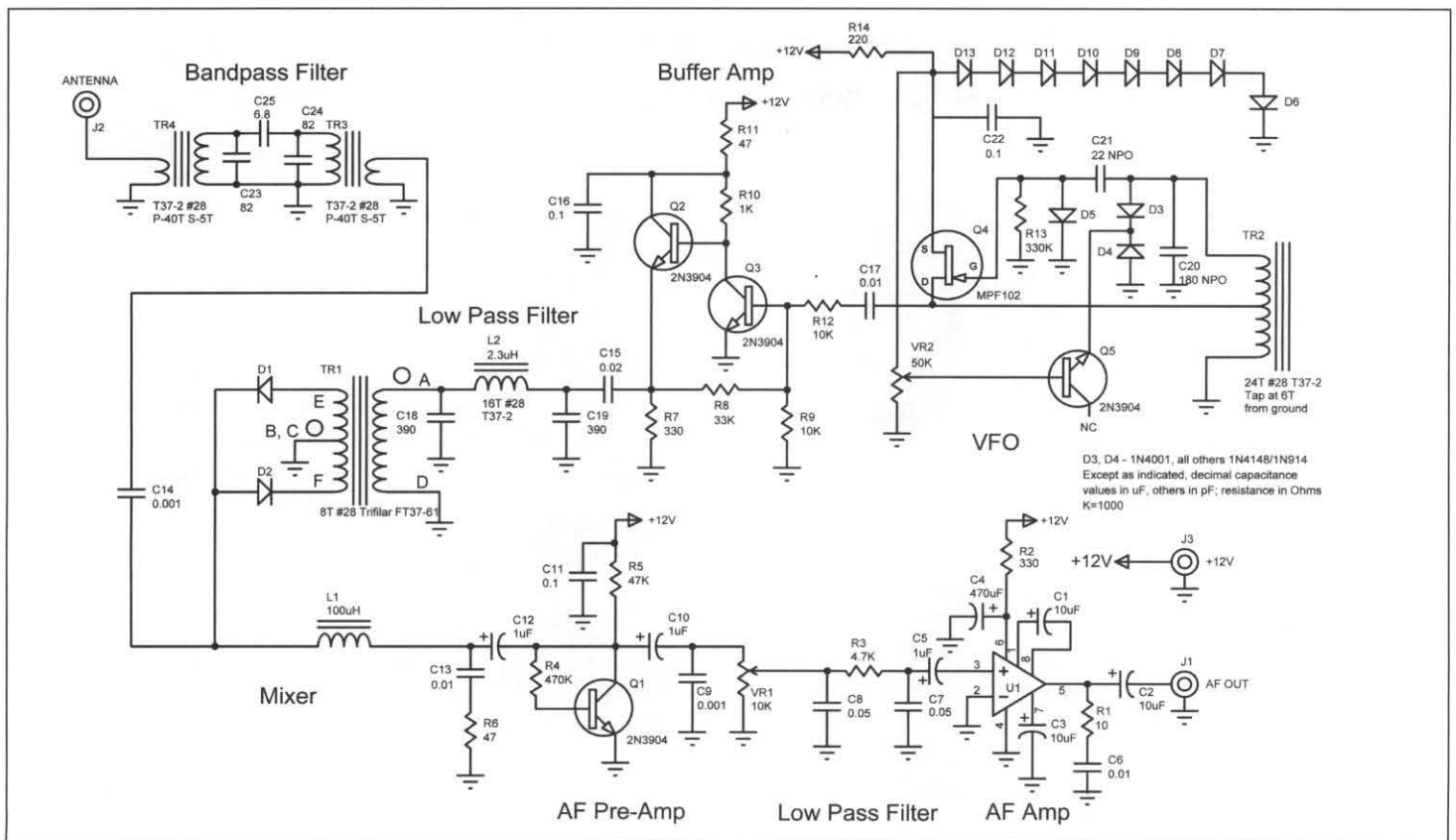

Figure 2—Schematic diagram of the receiver.

is adjusted. I found I could get about 10 kHz of frequency swing on 40M with this arrangement.

Q4 is configured as a basic Hartley oscillator. D5 provides a stable bias for oscillation. RF energy is tapped off the source through C17 and is amplified by Q3 and Q2. This buffer amplifier also helps ensure stability in the VFO. Their output is filtered by low pass filter L2, C18, and C19 to present a nice clean signal to the mixer.

The diode chain, D6-D13 serves as a nice voltage regulator—avoiding a more difficult to find voltage regulator IC or Zener diode. Each diode provides about 0.7 V voltage drop. With (8) 1N4148 diodes from Radio Shack configured as shown, I measure exactly 6 volts at the hot end of C22 (the filter capacitor).

Q5 is an interesting WIFB trick that I found in QRP Classics (originally, Tuning-Diode Applications and a VVC-Tuned 40-m VFO, in the September, 1987 QST). When current flows through an inductor or a capacitor (the frequency determining parts of an oscillator), they heat and expand (ever so slightly). The result is a change in the capacitance or inductance of

the part, causing the frequency of the oscillator to drift. The when the base-emitter junction of an NPN transistor heats, its resistance changes causing drift, but in the opposite direction of the inductor/capacitor drift—so the net result is, a much more stable VFO (I found my VFO to be stable  $\pm 20$  Hz after 10 minutes warm-up).

The mixer (TR1, D1, D2, C14, and L1) and the AF Pre-Amp comes from Rev. George Dobbs' Quick Receiver (from the 1998 Four Days In May Proceedings) and is a basic singly-balanced mixer. The AF Pre-Amp (Q1, et al) is necessary to overcome the 6 dB or so of conversion loss that the two-diode mixer exhibits.

VR1 serves as a volume control. The incoming audio is filtered by R3, C8 and C7. This is a very simple RC filter that appears in Paul Harden, NA5N's *The Electronic Data Book for Homebrewers and QRPers*—no home-brewing enthusiast should be without this book! The filter is used in MFJ QRP rigs. While not very sharp (its Q is under 1/2), it does provide noticeable high frequency roll-off, and makes the receiver much more selective.

Finally, the major amplification (46 dB) occurs in U1, an LM386-1 integrated

circuit. This IC is just about the cockroach of communications IC's, and every Radio Shack store I checked had at least one and most had more than one (RS part number is 276-1731) in stock. You may notice that C3, the bypass capacitor is larger than many LM386 circuits you may run across—the National Semiconductor data sheet for this IC recommends a value of 10  $\mu\text{F}$ , and I found several references that indicate the lower values (I've seen it as low as 0.47  $\mu\text{F}$ ) used in many circuits is of little or no value. Also, many circuits use a larger output capacitor at C2—the 10  $\mu\text{F}$  value in this circuit provides just a bit better low frequency response and a bit more hiss and high frequency attenuation.

### Construction Notes

The major difference between the original Tuna Tin 2 and the new Tuna Twin Too is pretty obvious—one is designed to transmit RF energy, and the other is designed to receive it. Because the transmitter uses a crystal-controlled oscillator, it is fairly easy to ensure that it only transmits on the desired operating frequency (that is the frequency selected by choice of crystal, within the 40M band).

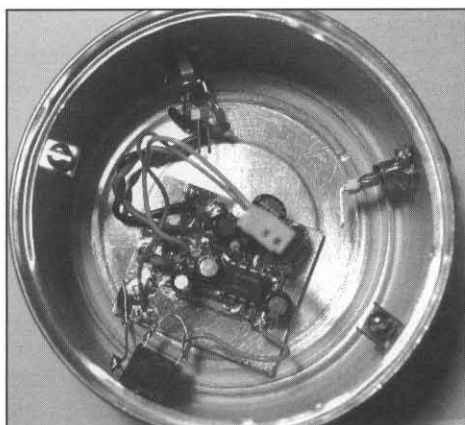

**Figure 3—Photo of the AF Amp inside the tuna tin.**

On the other hand, an S9 signal is nearly 2000 times weaker than the power output of the Tuna Tin 2—so you can imagine that a bit more work goes in to trying to receive a signal than in trying to send one, and that a whole lot of amplification is going on somewhere. Also, when you vary the frequency (say, to zero beat that juicy DX that's answering your CQ/TT2 call), the frequency should vary exactly how you want it to, no more or no less (that is, you don't want it drifting all over the place).

Finally, you would really like to hear only stations on or very near the frequency to which you have tuned; that is, you want a certain amount of selectivity. (I live exactly 3 miles from the transmitter for the 50,000-Watt clear channel station WSB. I once worked a Spartan Sprint using my Knightlights SMITE and not only did I work 6 stations, I got to listen to the Atlanta Hawks post game show at the same time!)

For all of these reasons, careful construction is a must. So while it looks really cool to put the 28 parts of the Tuna Tin 2 transmitter on the top (that is, outside) the

tuna can, it is a much better idea to put the receiver inside the tuna can. This provides good shielding, which very much helps keep extraneous signals (like WSB AM 750) from interfering with the station you really want to listen to.

The Tuna Twin Too uses over twice as many parts as its older brother. While it may be possible to squeeze all the parts onto a single board, I decided to think three-dimensionally, and built the audio amplifier on a small board in the bottom (using a form of Manhattan style construction) of the tuna tin, and the rest of the receiver on the underside of a piece of double sided PC board, the top-side of which became the cover for the tuna tin.

### Building the AF Amp

Build the AF amplifier first—it is one of the basic building blocks of the entire project and is easily tested. Make a photocopy of AF Amp board layout and cut out and paste (using glue stick or similar adhesive) the small PCB layout square to a piece of PC board material (either single or double sided). Take a Dremel or other hobby tool and carefully cut out the white areas, leaving copper in the black areas. If you are careful, you can remove all but the copper traces and areas where you will place the amplifier's components. Once you've cut (or at least marked) where all the copper is to be removed, use a piece of steel wool to remove the remaining paper. Then use the Dremel tool to finish removing the excess copper. Use a continuity checker to make sure that none of the pads touch each other or the ground plane.

Solder U1 in place first, and then put the other components around it. Be careful that you put it in the right way—pins 2 and 4 should be grounded (the dot on the IC is pin 1). Pay careful attention to the polarity

of wire and you should hear a noticeable hum.

Now that the AF amp is completed, carefully drill holes in the side of the tuna tin, as shown in the photo, and install J1, J2 and J3. Then install the AF amp on the floor of the tuna tin, using a small piece of double sticky tape or other adhesive.

### Building the VFO

After finishing the AF Amp, build the rest of the receiver on the under-side of the tuna tin cover. I built this part of the receiver "dead-bug" or "butt-ugly" style. Use the accompanying photo as a guide to cut out a piece of PC board, 3 inches in diameter. Mark holes for the two potentiometers, then place in a vise to drill the holes. BE CAREFUL HERE. It is NOT a good idea to hold the PC board in your hand while you are drilling holes, as it will slip and give you a nasty cut! Once you drilled holes for the pots, go ahead and install them. Note that in the photo, the volume control pot (10k) is wired backwards—the grounded pole should be the one closest to the tuning pot, not the one furthest away as in this diagram.

Build the VFO first (up to, but not including R12). Note the construction of the diode strip (D6-D13) from the "top" (pole closest to center of the board) to ground. Be sure that all the diodes are of the same polarity, with the banded ends towards ground. Also, put some electrical tape or something underneath the diodes as they span over VR2, so that they don't accidentally ground out. When you apply power, you should measure right around 6V at the D13/R14 junction.

To test, connect a spare 1 kohm resistor from the R12 side of C17 to ground. Apply power. If you have a frequency counter or oscilloscope, you can verify oscillation using the C17/47 ohm resistor as a test point. Otherwise, you can verify oscillation by placing the VFO very close to general coverage receiver tuned to 40 meters.

To test, plug a set of 8-ohm headphones into J1, and connect the circuit to power. Touch pin 3 of the LM386 with a small screwdriver or piece

of wire and you should hear a noticeable hum. Once you've verified oscillation in the VFO, turn VR2 to approximately its midrange point and tune the VFO oscillating frequency by expanding or compressing the turns on TR2.

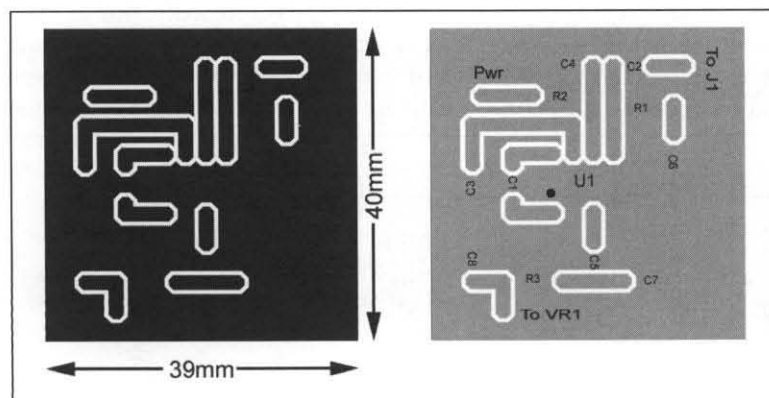

**Figure 4—AF Amp p.c. board (actual size).**

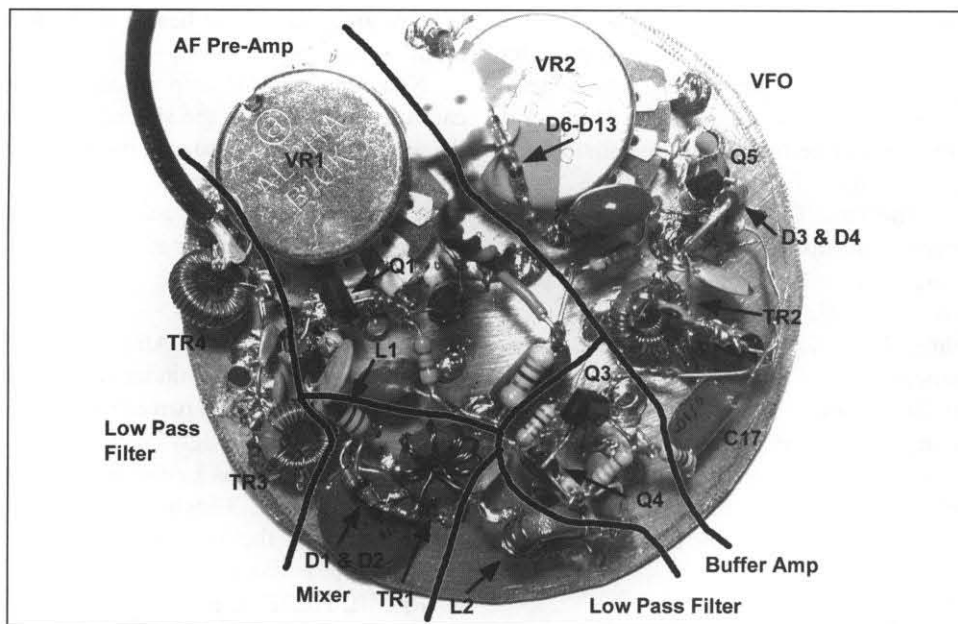

Figure 5—Layout of the circuitry installed “dead bug” style on the cover.

Remove the resistor that you connected to C17 and build the buffer amp up through and including C15. This is fairly straightforward—just watch the correct polarity on the 2N3904 transistors.

After constructing the Buffer Amp, connect a spare 47-ohm resistor from the Low Pass Filter side of C15 and test as you did previously with the VFO. Remove the 47-ohm resistor; construct the low pass filter, through and including C18. Connect the spare 47-ohm resistor from point A in the schematic (top of C18) to ground, and verify that you are getting output through the resistor (same as the previous two tests). If you look at this signal in an oscilloscope, it should be a fairly clean sine wave.

### Building the Mixer

Winding TR1 can be just a little tricky. Use three pieces of #28 enameled wire, or insulated wire of the smallest gauge possible, of about 10 or 11 inches in length. Twist the three wires into a neat “wire rope.” An easy way to do this is clamp one end of the wire in a small drill or Dremel tool, hold the other end with pliers and slowly turn the drill until you have a nice

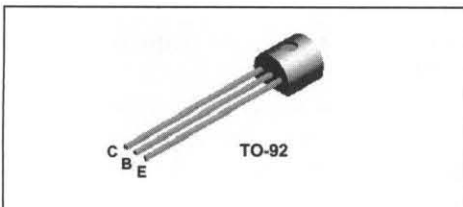

Figure 6—2N3904 pin arrangement.

“trifilar” winding.

Take the resulting “wire rope” and wind pass it through the FT37-61 toroid 9 times—that is, 9 turns through the toroid. Strip a little insulation off each wire and find the two ends of each of the three wires. Mark the two ends of the first wire “A” and “D” (use pieces of scotch tape or dabs of the same color of paint), the second wire “B” and “E” and the third wire “C” and “F.” Remove all the insulation from wires B and C to just shy of the coil winding (but far enough that they don’t short to the other wires), twist them together, and then solder.

Remove the insulation from wire D, to just shy of the coil winding. Solder the pair of wires B and C, and the single wire D to the ground plane (copper board), using these wires to support the transformer about 1/4 inch or so off of the board. Be sure that wire A is pointing somewhere towards C18, and wires E and F towards the unfinished part of the board. Remove the 47 ohm resistor you used to test the Low Pass Filter and connect wire A to C18

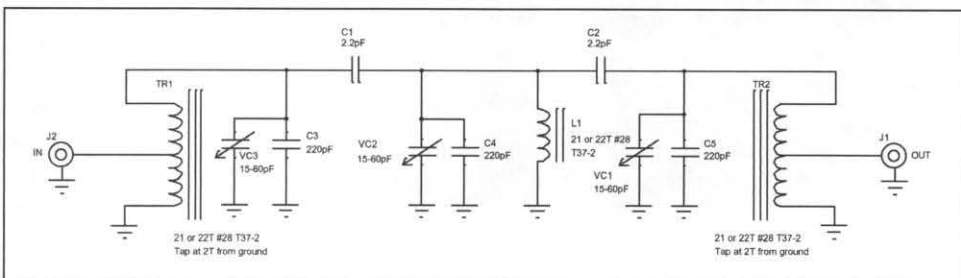

Figure 7—Diagram of the W7EL “G Filter.”

instead of this resistor.

Connect diodes D1 and D2 to wires E and F. It doesn’t really matter which diode connects to which wire, just make sure that one banded end and one un-banded end connect to the transformer. Add C14 and L1, and then use C13/R6 to hold them up off of the copper ground. Go ahead and build the AF Pre-Amp, towards the middle of the board, around the VR1 pot. Connect a wire from the wiper terminal of VR1 to the input (C8) on the Audio Amp board and another wire from the copper ground to the ground on the AF Amp board.

Connect an antenna or short piece of wire to the Bandpass Filter side of C14 and apply power. You should hear some signals through the headphones, and should be able to tune around the segment of the 40M band that you set when you adjusted the tuning during testing of the VFO by adjusting VR2. If you do not hear any signals or band noise, verify the AF Pre-Amp is working by touching the C13/C12 junction with a screwdriver or short piece of wire. You should hear a hum that varies in volume as you adjust VR1.

If the AF Pre-Amp is working, and you still do not hear any signals, verify that you have constructed the Mixer (TR1, D1, D2, L1 and C14) correctly. If you still do not hear any signals, then verify that you have output coming from the VFO and that the AF Amp is working properly.

### Finishing the Tuna Twin Too

Finally, build the Bandpass Filter. If you do not have room for this on the main board, you can build it on a small piece of PCB board and use double sticky tape (or hot glue) to secure it to the bottom of the tuna tin, near J2. Run a wire (or a short piece of RG174 coax if you have it) from the Bandpass Filter to C14. Connect an antenna to J2 and reapply power. You should hear CW signals, with less other “crud.” If not, first make sure that there really are signals on 40M (using another



receiver). If there are signals around 7040 kHz, make sure the Bandpass Filter is constructed properly, etc.

Finish off your Tuna Twin Too, by securing the top to the tuna tin. This is left as an exercise to the builder—it depends a lot on how you have built it. I used very small 4-40 screw “L” brackets (these are not available in Radio Shack stores, but are available at [www.radioshack.com](http://www.radioshack.com), part number 910-2971). Add finishing touches like knobs (I used 274-416 which come in a package of 4) and labels and you’re done!

### Death By QRM

As I mentioned before, I live exactly three miles from the 50 kW WSB AM radio transmitter on 750 kHz. So even with good shielding and the bandpass filter, I occasionally had a little bit of BCI on my receiver. Worse, at nights, there is a religious broadcaster somewhere around 6800 that just wiped the whole thing out.

In the RSGB *Low Power Scrapbook*, p. 125, Roy Lewellan, W7EL, shows a very neat filter he called the “G Filter.” It is a triple-tuned (three resonator) filter designed to deal with the nasty conditions on 40M in Europe. I built a version of this filter in an Altoids tin, and when I need a better filter, I stick it between the antenna and the receiver input. I found that in order to tune my filters, I had to remove one turn from each inductor, using 21 turns instead of 22. Although the filter has about 9 dB of insertion loss, its “skirt” is about 70 kHz wide, and the SW station that wipes out my receiver at night is long gone.

If you were able to build your Bandpass Filter on the top board, you may be able to build this filter on the floor of the tuna tin. Or, you may wish to replace the bandpass filter in the schematic with this triple tuned filter. If so, you may wish to add an extra stage of AF pre-amplification to overcome the insertion loss.

### On the Air-Summary Comments

This receiver is not going to earn any awards in performance, but it does indeed work. Its performance can be expected to be on par with the entry-level kits available at hamfests and online (such as the Ramsey and Vectronics kits).

The very first contact that I made, using the Tuna Tin 2 and the Tuna Twin Too was with KG4UOA. I called CQ (on 7041.5 kHz which is where my TT2 crys-

tal ends up transmitting at) a couple of times and Brandon in Wilmore, KY came back to me. Nice signal, and copy was fairly easy at first. Then it suddenly became very difficult to copy, as another station, probably 2 or 3 kHz away, totally wiped out my copy of his signal. We did manage to complete the QSO, but it was rough (that is when I decided to add the AF Low Pass Filter).

What is so great about this hobby is, it was Brandon’s VERY FIRST QSO as an amateur radio operator. He had received

his license that same day in the mail from the FCC. It doesn’t get any better than that, folks!

There’s really nothing original in this receiver at all. It is based on tried and true circuits, but the elegance is in the simplicity. Were W1FB around today, I think he might just smile. Then he’d grab a key, plug a jumper to the Tuna Tin 2, hook up an antenna and some power and start calling CQ!

—72 de Mike, KO4WX



PARTS LIST		
Part Number	Value	Radio Shack Part Number
C1, C2, C3	10uF 16V electrolytic	272-1025 (35V)
C4	470uF 16V electrolytic	272-1030 (35V)
C5, C10, C12, C17	1uF 16V electrolytic	272-996 (non-polarized, can use)
C6, C13	0.01uF ceramic	RS 272-1065
C7, C8	0.05uF ceramic (or 0.047uF)	RS272-1068
C9, C14	0.001uF ceramic	272-801 (assortment kit)
C22	0.1uF ceramic	272-1069
C15	0.02uF ceramic (or 0.022uF)	272-1066
C18, C19	390pF ceramic	272-801 (assortment kit) or 272-809 (assortment kit)
C20	180pF NPO ceramic	272-801 (assortment kit) -maybe 272-809 (assortment kit) - maybe
C21	22pF NPO ceramic	272-801 (assortment kit) - maybe 272-809 (assortment kit) - maybe
C23, C24	82pF ceramic	272-801 (assortment kit) or 272-809 (assortment kit)
C25	6.8pF ceramic	272-801 (assortment kit) or 272-809 (assortment kit)
R1	10 Ohms ¼ Watt	271-1301 (pack of 5)
R2, R7	330 Ohms ¼ Watt	271-1315 (pack of 5)
R3	4.7K Ohms ¼ Watt	271-1342 (pack of 5)
R4	470K Ohms ¼ Watt	271-1133 (pack of 5, ½ Watt)
R5	47K Ohms ¼ Watt	271-1342 (pack of 5)
R6, R11	47 Ohms ¼ Watt	271-1105 (pack of 5, ½ Watt)
R8	33K Ohms ¼ Watt	271-1129 (pack of 5, ½ Watt)
R9, R12	10K Ohms ¼ Watt	271-1335 (pack of 5)
R10	1K Ohms ¼ Watt	271-1321 (pack of 5)
R13	330K Ohms ¼ Watt or 220k+100k in series (may be able to use 220K)	Try 271-1132 (220K fi Watt) + 271-1347 (100K fi Watt)
Q1, Q2, Q3, Q5	2N3904 (or equivalent)	276-1617 (15 pack assorted NPN) or 276-2016 (MPS3904)
Q4	MPP102	276-2062
TR1	8 turns #28, trifilar on FT37-61	
TR2	24 turns #28 T37-2, tap at 6 turns from ground	
TR3, TR4	Primary, 40 turns #28 on T37-2, secondary, 5 turns #28	
L1	100uH RF choke	273-102
L2	2.3uH, 16 turns #28 on T37-2	273-1601 (assortment kit) - maybe
VR1	10K variable resistor (audio taper)	271-1721
VR2	50K variable resistor (linear taper)	271-1716
D3, D4	1N4001	276-1101 or 276-1653 (assort. kit)
D1, D2, D5, D6, D7, D8, D9, D10, D11, D12, D13	1N4148 or 1N914	276-1620 (pack of 50)
U1	LM386	276-1731
J1	1/8" stereo headphone jack	274-246 or 274-249 (pack of 2)
J2	RCA jack	274-346 (pack of 4)
J3	Coaxial power jack	274-248

# Improved AGC Performance for the Sierra Transceiver

Larry Wilson—KFØN

lrwilson@msn.com

Several years ago I received a Sierra CW transceiver kit from the XYL for Christmas. After an enjoyable assembly and alignment experience, this little radio turned out to be a great performer. Its small size and low-current drain make it a natural choice for either battery-powered portable operation or fixed station use.

Initial operation, however, revealed a pronounced “thump” from the receive audio during the AGC attack period. Since the receiver employs an audio derived AGC scheme (as opposed to IF derived), I thought that further improvement in the AGC performance was not likely. A few evenings at the workbench, however, yielded a significant improvement in performance after installing the modest circuit modification described herein.

To understand the modification, we need to look at the original AGC circuit and see how it works. The original circuitry is partially reproduced for reference (Figure 1). Audio from the final AF amplifier U3, is coupled through C22 (0.047  $\mu\text{F}$ ) to the AGC detector diode, D1. The half-wave detected audio signal is then filtered by the parallel combination of R5 and C26, which comprise the receiver's main AGC filter circuit. The R-C time constant of components R5 and C26 determine the AGC discharge time. The AGC attack time is determined by the time required to charge C26 from the series combination of coupling capacitor C22 and diode D1. For this discussion, I am ignoring the AGC threshold adjust circuit (R3 and R21), because the impedance of this circuit is essentially swamped by the relative low impedance offered by C26 during the AGC attack period. Due to the relatively small value of capacitor C22, several tens of cycles of detected audio are required to fully charge C26 during the attack period and stabilize the AGC loop. The result is the noticeable “pop” in the audio output during the attack. Based on this analysis, we might be tempted to increase the value of C22 to speed up the charge time. However, the 0.047  $\mu\text{F}$  capacitance value was probably chosen by design to minimize distortion in the audio path that might otherwise be introduced by the AGC detector diode.

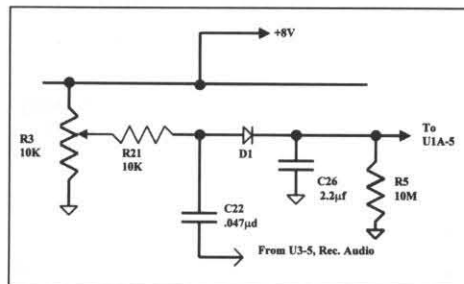

Figure 1—The unmodified AGC circuit.

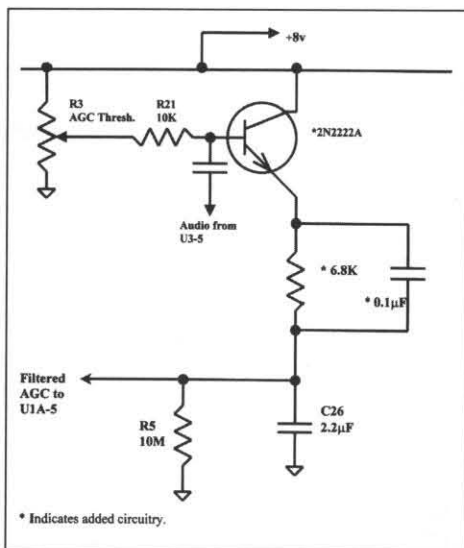

Figure 2—Modified Sierra AGC circuit.

The modified circuit is shown in Figure 2, where the transistor circuit replaces detector diode D1 as shown. The circuit is a basic emitter-follower, with the active device biased at or near cut-off (depending upon the setting of AGC threshold pot R3). Audio is applied to the transistor base from C22, and detected by the base-emitter junction of the transistor. The detected audio signal is amplified by the current gain of the device to rapidly charge AGC filter capacitor C26 from the emitter. The effect of the modified circuit on the attack time is twofold: first, the impedance of the active transistor detector loading C22 is greatly increased due to the current gain of the device, and second, the source impedance from which C26 charges is correspondingly reduced due to the same current gain. If my memory is correct, the nominal attack time decreased from over 60 milliseconds for the original circuit, to 15 milliseconds or less for the modified version.

The modified circuit uses a 6.8 kohm resistor in series with the transistor emitter to ensure AGC loop stability. You could reduce this value to around 2.2 kohms for a little faster attack time, but I found that values less than this tend to make the loop unstable and prone to AGC overshoot. The 0.1  $\mu\text{F}$  parallel capacitor across the 6.8k resistor provides a small amount of lead charge to C26 during the initial attack period for a slightly faster attack time.

The transistor type is non-critical. I happened to have a 2N2222 left over from the kit build because I had substituted a 2N918 for PA driver transistor Q6 for a slightly improved gain-bandwidth performance for the transmitter. I used this 2N2222 for the AGC modification, but any small-signal NPN transistor you might have in your shack's junk box should provide acceptable performance.

I assembled the three added parts onto a small repair strip consisting of a printed circuit “any-board” similar to Radio Shack item #276-150. I then glued the board as an edge-mounted assembly to a convenient location on the underside of the Sierra's main board using 5-minute epoxy. Diode D1 was removed, and the new board wired into the main board using #30 AWG insulated bus wire. When doing this, don't forget to hook the collector of the transistor to the 8-volt supply bus. Things won't work too well without this connection, and it is easy to overlook! Also, don't forget to readjust R3, the AGC threshold pot, because this adjustment will have changed slightly from the original setting. Follow the general procedure under the “Operation” section of the Sierra manual.

My radio does not have the noise blanker option installed, and the noise blanker may mitigate the AGC attack problem somewhat by providing a blanking pulse during the AGC attack period. However, it is possible that reducing the AGC attack time produces a corresponding reduction in the length of the blanking pulse, provided one is generated during AGC attack. In this regard, the modification may still be worth installing and provide enhanced receiver performance if used in conjunction with the noise blanker.

••

# QRP, QSOs and QSLs—The Joys of a Rookie QRPer

Rev. Fred Hembree—N4SSD

n4ssd@arrl.net

Just a few days ago while working on the computer, I had my HF rig tuned to 14.060, the QRP CW calling frequency. While I was typing away on a project for the office, I heard a long slow CQ. To my surprise no one answered. Now, I don't know about you, but I hate to hear a CQ go unanswered! The call was KL7AM, and after he called CQ again, I put my computer work on hold, turned around to my HF rig and went back to him using 5 watts of power. The following is part of that QSO...

**N4SSD DE KL7AM**

UR RST 469, 469 WITH QRN. QTH IS FAIRBANKS, ALASKA. PLEASE GIVE ME YOUR CALL AGN? K

**KL7AM de N4SSD**

MY NAME IS FRED AND QTH IS MURFREESBORO, TN. UR RST 579, 579. HOW COPY? K

**N4SSD de KL7AM**

GOT UR CALL OK FRED IN MURFREESBORO, TN. GLAD TO QSO WITH YOU FROM FAIRBANKS, ALASKA. NAME HERE IS BOB. MY AGE IS 94. BORN IN HONOLULU, EDUCATED AT MIT AND HAVE ATTENDED SEVERAL OTHER UNIVERSITIES. AM A MATH PROFESSOR, SCIENTIST AND ENGINEER. HOW COPY? N4SSD DE KL7AM K

**KL7AM de N4SSD**

FB ON ALL...SOLID COPY. RIG HERE IS AN ICOM 761 RUNNING 5 WATTS QRP INTO A LOOP UP ABOUT 35 FEET. BORN IN TENNESSEE AND WENT TO SCHOOL AT VANDERBILT UNIVERSITY AND COLUMBIA SEMINARY. AGE IS 47 AND OCCUPATION METHODIST MINISTER. BACK TO U. KL7AM DE N4SSD K

The QSO continued for about 30 minutes, and I won't go into all the details but it was a very exciting and enjoyable contact for me. As a relatively new member of QRP-ARCI, it is amazing to me what can be done on 5 watts or less with a simple wire antenna! My first area of specialization in amateur radio was chasing DX and

I still enjoy DXing even though most of my DX buddies think I've lost my mind going QRP. But the challenge of working distant stations on 5 watts or less is for me every bit as exciting as working persons in rare and exotic lands. So, how about QRP DXing? This just gets more and more fun!

QRP operation has caused me to develop my CW skills, and while I am certainly not a speedy CW op, I am improving my ability to send and receive over time. One interesting aspect about QRP CW is that you can usually find folks using CW at speeds comfortable for you. While there are those more seasoned ops who go at a peppy pace, there are also plenty of folks out there who will take their time to work you. Most ops will try to QRS (slow down) if necessary to enable a better QSO for you. If you are rusty on CW, just jump on in somewhere near one of the QRP CW calling frequencies such as 7.040 on 40 meters or 14.060 on 20 meters. Folks there will be delighted to work you at your pace and will put up with any CW mistakes you may make. In fact, I have found most of the QRP community to be exceptionally nice at encouraging others to keep up the good work with QRP CW. The reason I know this is, I have made my fair share of mistakes sending CW and folks have certainly been patient with me! HI HI

In addition to QRP operation, I really enjoy sending and receiving QSL cards. I have made some homebrew cards using the QSL Maker program available through the QRP-ARCI website links. However, my current QSL card is a "store bought design" that I secured via a professional card printer. A picture of my QSL card reveals the US Flag and the QRP-ARCI Logo along with my callsign, name and address. When you go to the mailbox it is a pleasant surprise to receive along with the usual bills and other mail, a QSL card

or two. It makes going to the mailbox a real treat to see what you may discover waiting there for you. QSL cards serve as a pleasant reminder of a QSO enjoyed days, weeks or even months ago. QSLing adds just an extra bit of zest and fun to our hobby, don't you think?

I will be putting a QSL card in the mail to KL7AM soon. As the mail arrived at my QTH today, I received a QSL card from John K9HLT in Blandinsville, Illinois. We worked each other QRP CW on 14 June 2002 on 7.040. He was running QRPp at 750 mw! As I put his QSL card into my card file for storage, I took a moment to casually enjoy and review some other nice QSLs I have received recently. There was a nice one in full color from Bill K4BX in Spring Hill, Tennessee that included a picture of him and his Elecraft rigs. There was one from Dick K5TF in Atlanta, Georgia that reminded me of our QRP QSO when he was using a Tuna 2 at 350 mw! One card from John KC8PXF of Painesville, Ohio, featured a picture of his Vibroplex iambic paddles and confirmed our QRP QSO in which he was using a RedHot NC20 at 5 watts to a dipole up about 30 feet. There was one from Joseph K5LQ in Brandon, MS, who was the first contact made on my Ten-Tec Model 1340 kit radio. I was running 3 watts and was so pleased that the little T-kit was doing well. There was one from Vincent W8ZJE in Adrian, MI, who wrote, "My pleasure to meet U and enjoy a fb QSO! Ur lil QRP rig sure was carrying the mail up this way...keep up the QRP CW...age here is 85 yrs—still pounding brass HI and 73."

Yes...QRP operating, along with interesting QSOs, and fascinating QSL cards have made my life richer and more enjoyable. These are the simple joys of a rookie QRPer.

—73 and 72, de Fred, N4SSD

●●

## DON'T MISS AN ISSUE OF QRP QUARTERLY !

Check the mailing label on this issue. If it has the words "OCT 2002" then it's time to renew. DO IT NOW! — You can send in the form on page 64, or renew online using your credit card and QRP ARCI's PayPal service. Just point your browser to: <http://www.qrparci.org>

# Digital QRP Homebrewing

George Heron—N2APB

n2apb@amsat.org

**T**he Digital QRP Breadboard project has come a long way in four issues! As chronicled in these four issues, we've presented modules for the "brains" (microcontroller), the "eyes & ears" (LCD and keyboard), and the "voice" (precision frequency source). We've even created a special reflectometer to measure SWR and a software voltmeter to get the readings into the system. Now it's time to pull it all together to create the first instance of our full-blown, high-performance Digital Breadboard system. Many readers have asked about the "big picture" for this adventure...well, here it is!

In the second part of the column, per usual, we spotlight a novel microcontroller project to satisfy the digital homebrewing hunger out there. This time we continue evolving the PIC-based APRS Weather Station Project of NKØE. Dave Ek takes us another step along his "PIC-WX" project with a tutorial on the basics of asynchronous serial communication using the PIC16F84 and ends up with a software UART that will talk to your PC. Do your homework as directed herein and you'll soon have the start of your PIC-WX station.

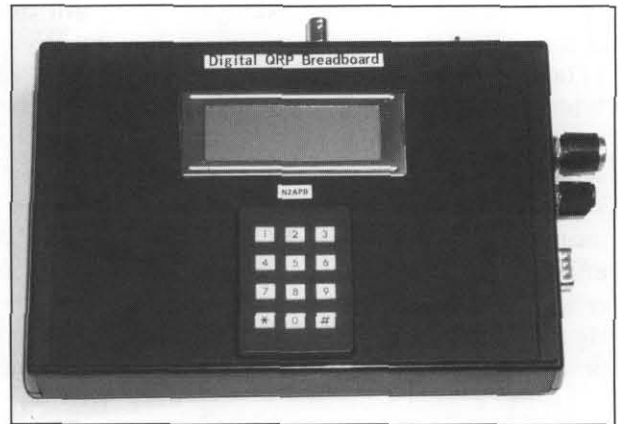

An advanced prototype of the Digital QRP Breadboard is pictured here in a 6 x 9 x 1 inch plastic enclosure with the LCD and keypad on the top, and most connectors along the top edge of the unit.

## The Digital QRP Breadboard...Part 5: "Baseboard & Enclosure"

In this installment of the project we tie up some loose ends by describing a couple of small hardware modules and then pull everything together with a baseboard design and enclosure. A master software program, including diagnostics, then makes all the components dance in unison to create an extremely flexible and powerful device for your ham shack.

### Form Factor

First, some discussion is required concerning about "form factor"—the way the hardware modules are physically constructed and integrated into the project as a whole. As the Digital Breadboard evolved over the last 12 months, I described that the various functional modules would be provided as small plug-in daughtercards to help with re-use and upgrade of the specific functions like the DDS, reflectometer, audio amplifier and others. I started laying out the baseboard pc board containing these daughtercards, but it quickly became apparent that this approach would be more expensive as compared to designing a single, integrated PCB containing all the functionality.

In order to keep the cost of this project as low as reasonably possible, I therefore opted to design each module directly into the layout for the baseboard, except for the

HC908 microcontroller. The HC908 will continue to be provided as a daughtercard—in part for those who have purchased it along the way, as well as because the microcontroller surface mount package cannot easily be soldered on by homebrewers. It's also a very useful module that can be used other projects when kept in this small daughtercard format.

Thus, you'll see that the Breadboard now consists of a dense baseboard containing most of the circuits and connectors/controls, and two plug-in modules: the HC908 Daughtercard and a DSP daughtercard which is coming in the near future.

This isn't too much of a deviation from our original course, and I think most will appreciate the lower cost of the ultimate system. To retain the flexibility of being able to replace or upgrade any given module, even though it's integral with the baseboard, I've laid out each module such that its I/O signals are conveniently located in one spot. This way, should you decide to "upgrade" your DDS chip (for example) to a newer/faster version, all you'd need to do is slice some traces at the indicated points, insert a pinheader at the module's I/O pads, and plug your own custom daughtercard onto the baseboard above the existing DDS circuit.

### Module Inventory

Referring to the schematics shown in

the following pages, let's go through a module-by-module inventory of the Digital Breadboard and see what functionality we have as a system:

**HC908 Daughtercard**—The brains of the Breadboard is contained in this removable microcontroller daughterboard which holds the powerful-yet-inexpensive 68HC908AB32 microcontroller by Motorola, with lots of memory and I/O, and peripherals like counter/timers, asynchronous serial ports, and A/D converters. The HC908 daughterboard also contains the clock, reset pushbutton, voltage regulator and RS-232 drivers. As previously discussed in detail, the software supplied with the project allows for easy self-programming of the chip—just download new software programs to the chip and it burns the code into its flash memory. No need for special, expensive or complicated programming hardware with this project! By the way, you can find the HC908 Daughtercard schematic in the second installment of this column (QQ for January 2002). It's also available online at the project's website—see the References section at the end of this column.

**DDS**—The Analog Devices AD9850 Direct Digital Synthesis (DDS) chip is used to generate frequencies for stimulus, analysis and measurement. Signal generation is possible from the sub-Hertz region to over 30 MHz, providing the Digital



The Breadboard tips up to allow easy operator interface when a bail is raised, as shown in this side view. The AUX connector provides the homebrewer with additional connectors for getting custom signals in and out of the device.



The rear view of the Breadboard shows how most of the PCB-mounted controls and connectors are arranged along the back panel.

Breadboard with a superbly-precise, accurate and software-controllable source of stable signals for use in a variety of experiments. The DDS module includes a 100 MHz oscillator to drive the clock input of the Analog Devices AD9850, thus enabling the device to generate a maximum usable frequency of 30 MHz. A 5th-order elliptic filter is used on the output of the DDS to ensure that a clean sinusoidal signal of about 750 mV is produced. This signal can be configured to go directly to the BNC at the edge of the board or go on for additional processing.

**RF Amp**—Since the DDS puts out a relatively small signal all by itself, a Mini-Circuits MAR-3 amplifier is optionally provided in the path to boost the signal and make it more useful in a reflectometer application. This tiny amplifier provides 8 dB of gain, as set by the bias resistor and inductors on the common output/bias port, and enables the reflectometer in the following stage to achieve better low signal performance. The builder may configure this amplified RF signal to be routed to the BNC connector or go on for yet additional processing.

**Reflectometer**—The reflectometer, or SW bridge, was presented in the last issue of this column. The middle 1N34 diode samples and rectifies the AC imbalance in the Wheatstone bridge to produce a DC representation of the signal reflected back from the output circuit on the BNC connector (e.g., an antenna system.) The other

two diodes sample and rectify the forward path and the load side to produce voltages representing the forward signal and the impedance, respectively. The three DC voltages are presented to the next stage for buffering and amplification.

**Compensation & Buffer Amplifiers**—This two-stage module utilizes true rail-to-rail op-amps for better low-signal performance. The first stage in each signal path employs another 1N34 diode as its feedback element of a unity gain amplifier to compensate for the nonlinearities of the diodes in the previous stage. This enables the component measurements to be much more accurate at QRP levels. The second stage boosts the voltage to better match the 5V full scale range of the A/D converter of the HC908. It also transforms the low impedance of the first stage to about 100K in order to present a better condition to the 10k-ohm input impedance of the A/D.

**Liquid Crystal Display (LCD)**—LCDs have become commonplace in our microcontroller projects. The Digital Breadboard uses an inexpensive 4-line by 20-character/line device to display status and measurement information to the user. The software driver for this display assumes that a common HD44780 controller-based LCD is used, so one could actually use a larger or smaller LCDs fairly easily instead of the specified one. One could also upgrade the Breadboard's capabilities to use a graphic LCD with an appropriate software driver in place.

**Keypad**—A 12-button keypad is provided on the Digital Breadboard to give the user an ability to perform direct numeric input. This is useful in VFO frequency-setting applications, or for configuration and data entry situations. The keypad also serves as a splendid set of general purpose pushbuttons that can be assigned whatever function desired by the user. Hence there are no other separate pushbuttons provided in this project. Whenever a key is pressed, an interrupt is issued in the HC908 and the software scans the 4 row x 3 column switch matrix to determine which key has been actuated. This key code is returned to the software routine that is expecting the input.

**Keyboard**—A standard PS2-style keyboard, similar to many keyboards used on PCs these days, can be used with the Breadboard. The importance and utility of this input device will become more apparent in the near future when we introduce the final module, the DSP Daughtercard. This combination of DSP co-processing and fast alpha-numeric input by the operator is the basis for PSK31 and other digital modes intended to be supported by this project. The Dauphin keyboard used with the prototype Breadboard thus far, as pictured in previous columns and on the website, is a small PS2-style keyboard that is ideal for portable use with the project. The NJQRP has acquired a number of these neat little keyboards and will provide them with the Breadboard system when we begin production.

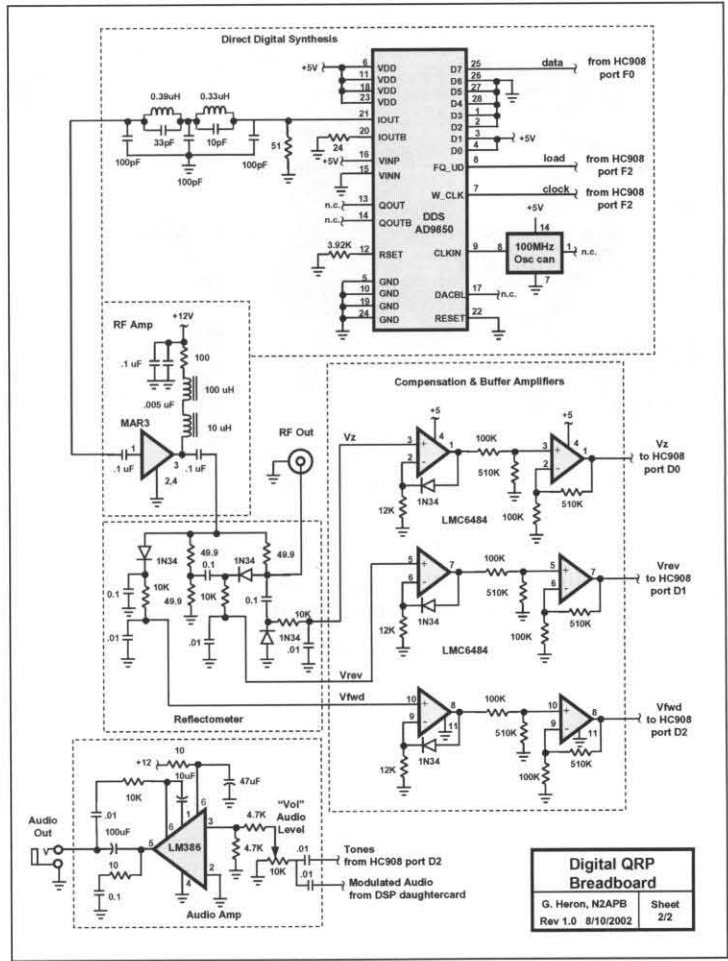
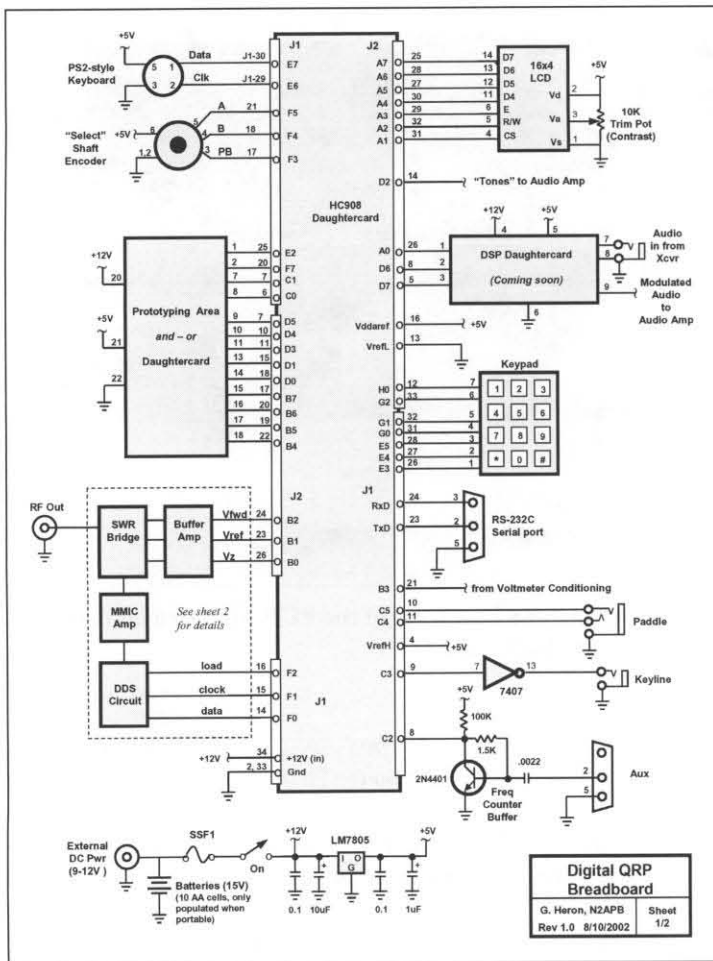

Schematic diagrams of the Digital QRP Breadboard.

**DSP Daughtercard**—Perhaps the final major hardware module currently being designed for the project is a daughtercard containing a DSP intended for audio processing. One of the many goals for the Breadboard continues to have it perform as a stand-alone digital mode controller, allowing the user to communicate using PSK31 (et al) without the need for a completely dedicated PC. This DSP card, initially containing an Analog Devices ADSP-2189 digital signal processor and mating codec (integrated A/D and D/A converter), is fast enough to demodulate the audio signals coming from your transceiver's speaker, and then simultaneously modulate the data you type on the alpha keyboard and send that audio out for input to your SSB rig.

**Prototyping Area**—Although difficult to show on a schematic, the Breadboard PCB is being laid out to provide a small area approximately 2" x 2" that is populated with plated through holes. Looking like perforated breadboard, this area can be

used for personal experiments involving components not already provided on the Breadboard PCB. Further, all of the extra/unused signals are brought to the edge of this prototyping area so the homebrewer may wire-in any of the 13 available HC908 I/O pins for specialized purposes. Alternatively, or in addition to using hard-wired components in this proto area, the homebrewer could fabricate a small board to fit into those signal pads at the edge of the area, effectively producing a replaceable prototyping daughterboard that could be added/removed as the application warrants. Does this Digital Breadboard have flexibility? You bet!

**Miscellaneous Circuits**—A shaft encoder provides ultimate flexibility to the operator as a continuous rotation menu selector, numeric dial setting, frequency tuning, and so on. An input conditioning circuit serves as a front end for an electronic voltmeter and RF probe by presenting a buffered AC or DC signal to an A/D input on the HC908 card. A frequency counter

function is provided by having a transistor shape the sinusoidal waveform input to a pin on the AUX connector before presenting the signal to an edge-sensitive counting input of the HC908. Software determines the period of the applied waveform and the frequency is then calculated. A Morse paddle may be connected to an input jack and software on the HC908 performs as an iambic keyer, which in turn drives an external transmitter through the Keyline output jack. A tone is also sounded, under control of the HC908, and is output through an LM386 audio amplifier. This audio tone can be the sidetone for the keyer, the output for an Audio Voltmeter (see the N2CX article concerning such a project elsewhere in this issue), or mode confirmation beeps. Finally, room is provided within the Digital Breadboard enclosure for a ten AA cell pack, thus providing portable power for the field use of the unit.

### Software—The Master Program

As mentioned at the start, software run-

ning in the HC908 microcontroller makes all these hardware modules dance in unison to perform the various functions we want in the radio shack. The Master Program performs as a "real time executive" framework, of sorts, around which all other functionality and software operations are hung. As more features and capabilities are added to the Digital Breadboard, the software to control them will be merely added to this existing framework to provide an ever-growing, ever-capable list of "menu items" from which the operator can select.

A Main Menu is presented to the user on the LCD and all menu items are vertically scrolled by rotating the Select control (shaft encoder). When the desired menu item is displayed, depressing the Select control or the asterisk button on the keypad selects that item. Oftentimes a menu item has sub-menus to allow the user to select various options for the chosen operation. This user interface is quite intuitive, easy to learn and quick to use.

The following functions and capabilities are present in version 1.0 of the Digital Breadboard software: VFO, Voltmeter, Freq Counter, SWR Bridge, Freq Sweep, Impedance, Keyer, Keypad Test, Keyboard Test, LCD Test, A/D Calibrate, Serial Port Test and Program Load. This software comes pre-programmed on the HC908 Daughtercard, and it may be re-programmed locally by downloading the file

from the Breadboard's website and using the "Program Load" menu item with your PC connected to the RS-232 serial port. (This self-programming feature was described in previous columns and is on the website.)

We're short on space in this issue, but next time we'll fully describe construct and operation of the Digital Breadboard's software features.

### What's Next?

Well, there you have it—the completed first version of the hardware! It took five issues to bring the project to this point but there was plenty to chew on, absorb and try out along the way. As some of you know, we need some time now for the hardware availability to catch up with the prototype system as developed to this point, so the next several columns will be devoted to software—what makes this Breadboard tick and how you can use what we have so far. This will give the development team some time to catch up on making the baseboard PCB available and smoothing out the software so everyone's experience with this project will be very positive. After all, the end goal is to have a single box like this in the shack that can perform a multitude of functions merely by selecting the right menu item or by loading new software. In order to make it easy for the user, lots of work is needed behind the scenes...and

we're dedicated to doing it right!

Be sure to check out the Digital Breadboard's web pages for project updates and additional hardware/software detail. See you next time!

### NOTES

1) Visit the online web pages for the Digital Breadboard by pointing your browser to [www.njqrq.org/digitalhomebrewing](http://www.njqrq.org/digitalhomebrewing). Follow the links on the left side of the page to view the progression of this project, including color photos, diagrams, additional description and theory of operation, and software listings.

2) The NJQRP will be providing the entire Digital Breadboard project as a kit. The price is not yet established but will soon be with completion of the baseboard PCB. Check the online project pages (link above) to see the latest information on pricing and availability. Major components will be "optioned" to enable trimming of the project to your special needs and investment desires. Those who have already separately purchased the HC908 Daughtercard will be able to use it as-is with the baseboard.

3) Special thanks goes to my great friend and cohort in crime, Joe Everhart, N2CX, who has been a constant alter-ego in the conceptualizing and design of this project, and especially for use of his analog/RF circuits.

---

## Spotlight on ... The PIC Weather Station Project Part 2: Communications

Hi gang, it's Dave Ek, NKØE here again. Last time we got started with the basics of PIC circuits and PIC programming. Hopefully, you now have a PIC and a programmer, and you know how to use them. In this installment we'll begin to add useful functionality to our circuit by teaching it how to communicate with a PC via serial communications.

There are some PIC chips that have serial communication capability built-in, but the PIC16F84 isn't one of them. When I first began messing with PIC circuits, all I knew was the 'F84 and my home-built programmer, so without knowing any better I set out to code the serial capabilities manually. It turned out great, though, and I've since reused the very same code for other projects. Since the 'F84 is cheap and

easy to program, I've stuck with it despite the availability of superior PICs. That being said, let's get started!

### Serial Communications—An Overview

Since you might not be familiar with the nuts and bolts of serial communications, let's begin with an overview. You've probably had to set parameters like baud rate, stop bits, parity, and the like when using communications software on your computer. When your PC communicates with another device using its serial port, it sends a bunch of bytes (characters) one at a time. Furthermore, each byte is sent one bit at a time (eight bits to a byte). When a bit is sent, the voltage on the serial wire is set to one value for a "1" and another value for a "0." The specific values depend upon the type of logic in use (TTL, CMOS, RS-232, etc.).

We'll be concerned with two types of

logic: TTL, where 1s are +5V and 0s are 0V, and RS-232, where 1s are -12V and 0s are +12V. Note that these are typical voltages, but the specifications actually allow for a range of voltages for these values; we'll stick with these values for the sake of simplicity. Our PIC chip talks using TTL voltages, but the PC uses the RS-232 voltage levels. We'll need some way to convert between the two—more on that later.

We'll be talking exclusively about asynchronous serial communications here. That's where the common term UART comes from—Universal Asynchronous Receiver Transmitter. There is also a flavor of serial communications called synchronous, where the two communicating devices share a clock line to synchronize their chatter. In asynchronous communications, however, the devices are responsible for handling timing themselves and that's what we'll be focusing on here.

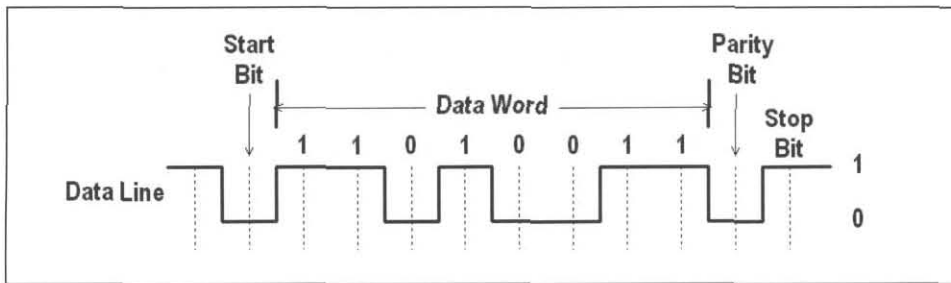

Figure 1—Serial communications bit stream

Let's look at a diagram of a typical stream of bits and see what sense we can make of it.

Here, voltage is the vertical axis of the graph, and time is the horizontal axis. Before any data is sent, the sending device holds the data line high (the "1" voltage). When it's time to transmit a byte, the sending device sends a start bit by taking the data line low (the "0" voltage). The start bit is the signal to the receiving device that data is coming.

The duration of each bit is determined by the baud rate set for the communications. A typical value is 9600 baud, which means that 9600 bits are sent per second, or each bit lasts for 1/9600 sec (0.000104167 sec). After the start bit is sent, each of the eight bits making up the byte is sent, with the most significant bit (the leftmost bit) sent first. The voltage of the data line changes to high or low depending on whether each bit is a "1" or a "0." Note that if two or more successive "1" bits are sent, the data line stays high for the duration of the bits—there is no "delimiter" to signal the end of one bit and the start of another. Thus, it's up to the receiving device to "time" the bits to determine when one bit ends and another begins. Usually, there are eight data bits sent for each byte, but it's possible to use only seven data bits if all the bytes to be sent are alphanumeric data because the most significant bit is always zero for alphanumeric characters (meaning their ASCII values are less than 128).

Once the byte is sent, a parity bit can optionally be sent. If even parity is chosen for the protocol, if the number of "1" bits in the byte is even, the parity bit is set to "1," or it's set to "0" if the number "1" bits is odd. If odd parity is chosen, the setting of the parity bit is reversed. It's also possible (and actually more typical) to select no parity for the protocol, in which case no

parity bit is sent.

Once the parity bit is sent (if parity is selected), the stop bit is sent. The stop bit is simply a "1," ensuring that the data line is held in the "1" state for a time before the next start bit is sent. Although only one stop bit is typically sent, it's possible to specify that one and a half or two stop bits are sent. In this case, the line is held in the "1" state for the duration of one and a half or two bits.

Obviously, both the sending and receiving devices must agree on the baud rate, the number of data bits, the number of stop bits, and the parity setting, or else there will not be successful serial communications between the two devices. Almost universally, eight data bits, one stop bit, and no parity are chosen. That's what we'll be using for this project. We'll also be using a baud rate of 9600. I chose this rather arbitrarily. Normally, faster baud rates are favored, but the amount of data exchanged between PIC and PC for this project will be small, and speed won't be an issue.

There is one other communication parameter that we haven't yet discussed: flow control. In some systems, the receiving device needs to signal the sending device to stop sending for a moment, perhaps to allow the receiving device to empty its receive buffer and process and store the data. Commonly, systems use either xon/xoff or hardware flow control. Frankly, I don't know much about flow control so I'm not going to discuss it in any detail here. The PIC WX project doesn't use flow control.

We've already discussed the difference between the voltage levels for TTL vs RS-232 logic. Our PIC chip uses TTL logic levels, but it must communicate with a PC that uses RS-232. Thus, we need to be able to convert between the two. Luckily, Maxim ([www.maxim-ic.com](http://www.maxim-ic.com)) makes a nice chip called the MAX232 that does this

for us. It requires a +5V supply and four 1- $\mu$ F electrolytic capacitors, and provides two channels of TTL-to-RS-232 conversion, and two channels of RS-232-to-TTL conversion. We only need one channel of each for this project. Simply put, the MAX232 chip is connected between the PIC and the PC, as you can see from the schematic below. You can get the MAX232 from a variety of sources, including Jameco ([www.jameco.com](http://www.jameco.com)). Get the MAX232CPE version.

The DB9F connector shown in the schematic is a female DB9 connector—you've undoubtedly seen one of these before, most likely on the cable end of a computer mouse. There are really only three pins that we care about on this connector. Pins 2 and 3 are the transmit and receive lines for the data, and pin 5 is the ground line. Some of the other pins are connected to each other: pins 1, 4, and 6, and also pins 7 and 8. This was done in case the PC expects flow control to be used. It's a way of faking out the PC into thinking that it's getting the correct response when doing flow control things. I'm not going to discuss this any further here, but the ARRL *Handbook* has some additional information if you're interested.

While we're on the subject, we need to discuss one other aspect of serial communications. Did you ever wonder why PCs have male connectors, and mice have female connectors? The obvious reason for this, of course, is so that you can plug your mouse into the PC! There's a little more to it, though. The circuit as shown above is wired as data communications equipment (DCE) so that it can be plugged directly into the PC, which is wired as data terminal equipment (DTE). Generally, DCE has a female DB9 connector, and DTE has a male DB9 connector. In addition, DCE sends data on DB9 pin 2 and receives data on DB9 pin 3, while DTE receives on pin 2 and pin sends on pin 3. Of course this makes sense since you want DCE to receive whatever DTE sends, and vice versa. If you want to connect DCE to DCE, or DTE to DTE, you need to use a null modem cable, which switches lines 2 and 3. That won't be necessary here.

### The Software UART

The code for the PIC is much more complex this time than it was for the first installment. I'm not going to cover it all in



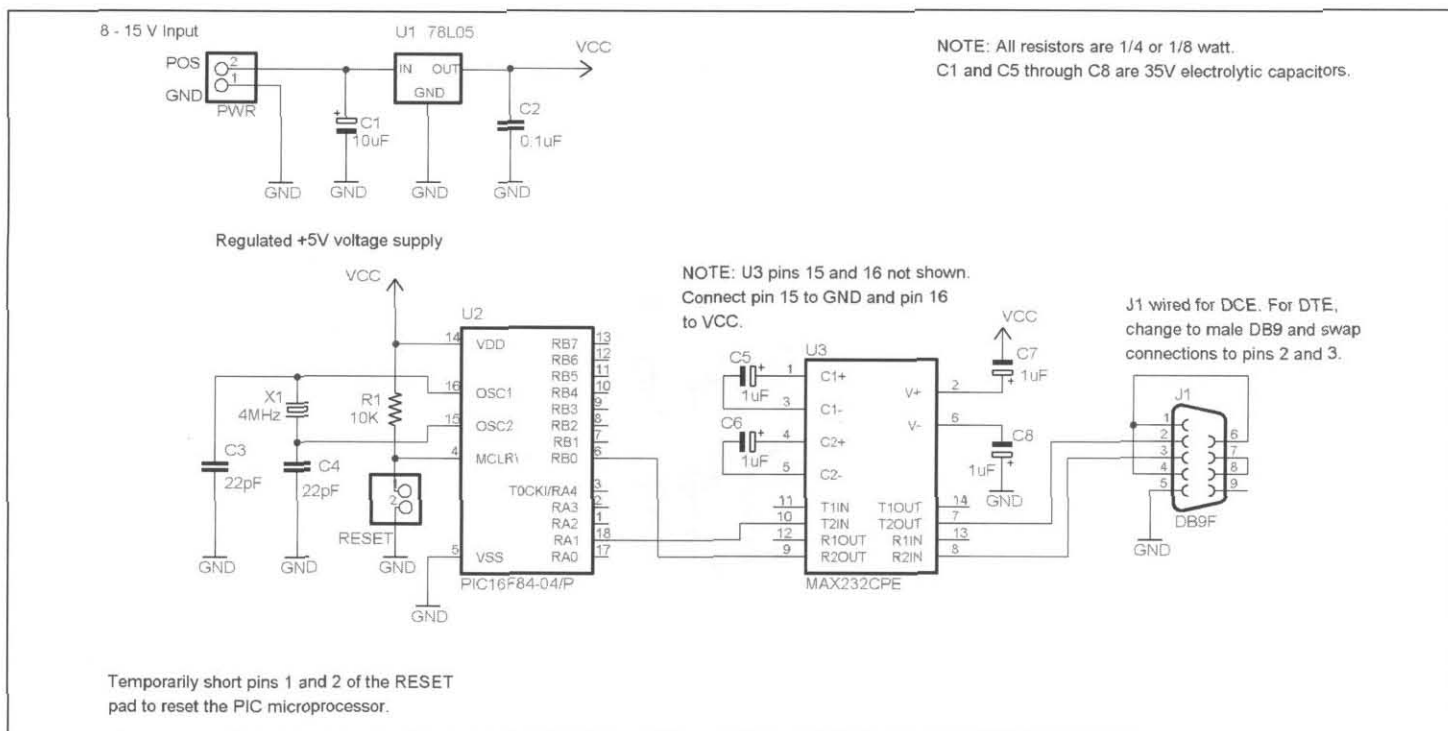

Figure 2: Schematic diagram for part 2 of the PIC WX project

great detail because of time and space constraints. Here are some highlights. First, most of the code is for handling the serial communications. The PIC always expects to get a command from the PC before sending anything, so it uses an external interrupt to know when the PC has sent a start bit. Pin RB0 on the PIC functions in this capacity when the external interrupt is enabled using the OPTION register. Then, when RB0 changes state, the PIC stops what it's doing and jumps to address 0x04 and begins executing code there. I've written code at that location to begin listening for bits and saving them. It does this by sampling the RB0 state at the same interval as the bit duration, checking in the middle of each bit. Once all eight bits have been received, the received character is placed in a file register for use by the program, and a flag is set in the SerialReg file register to indicate that a character was received.

Another type of interrupt, a timer interrupt, is used to wait for each bit to arrive. Instead of simply doing nothing between bits, the internal timer is set to generate an interrupt when it's time to check for the next bit. That way, the PIC can be doing other things while waiting for the next bit to arrive.

When sending characters back to the PC, a similar procedure is used. The timer interrupt is set to remind the PIC when it's

time to send the next bit. At those times, the PIC simply looks at the next bit and sets the RA1 line high or low as appropriate. When the character has been sent, a flag is set in the SerialReg file register to indicate completion.

This all sounds complicated, but to actually use these routines is easy. There are two subroutines, named GetAChar and SendAChar, which you can call. GetAChar continuously checks the SerialReg file register until the "character received" flag indicates that a byte was received. Then it returns, and the received character will be found in the RXBuff file register. GetAChar also does one other thing: it calls subroutine Idle, which can be used to do other things while waiting for the character to arrive.

Subroutine SendAChar works similarly. First, you place the character to be sent in the TXChar file register. Then you call subroutine SendAChar. It calls the appropriate serial routine to get the character sent, and waits for the flag to be set indicating completion. While it waits, it also calls subroutine Idle to allow for other processing to occur. Once the character has been sent, SendAChar returns.

Subroutine MainLoop handles the receiving and processing of commands. It calls GetAChar, and then checks the received command against the list of

allowed commands and calls the appropriate subroutine. If it doesn't recognize the command it simply ignores it. Here, there are two commands that will be processed. Sending a 't' from the PC will cause the PIC to return a five-digit number in ASCII form, that will change each time the command is received. A 'v' command from the PC will cause the PIC to return a version string.

### Your Homework Assignment

Your assignment now is to build the circuit shown in the schematic, program the PIC with the code for this installment (from the Digital QRP Homebrewing web site <http://www.njqrp.org/digitalhomebrewing/>), connect the whole works to your PC, and test it out using Hyperterminal or some other communications software. Remember to configure the software to talk directly to the serial port instead of a modem, and set it up for 9600 baud, 8 bits, 1 stop bit, no parity, and no flow control. Type a 'v' and see if you get a response, and then try typing 't' several times.

Next time we'll be adding our first weather sensor to the system—a temperature sensor. Should be lots of fun!

—73, Dave NKØE  
ekdave@earthlink.net

# The Electroluminescent Receiver

David White—WN5Y

wn5y@yahoo.com

When the Ancient Chinese thought about a thing as much as possible, they said they “Exhausted the Wisdom of The Hundred Schools.” I have about fifty references, and will never quit thinking of ways to improve it, but I now have a truly modern DX receiver for the Ham Bands, with state-of-the-art stability availability, digital readout, and LEDs that not only light up like a radio should, but add substantially to the end result. It is not finished, and never will be, but I have a parts kit and two large, silk-screened boards. So I turn to the Philosopher Lao-Tzu and paraphrase: “A journey through the Hundred Schools costs about a hundred bucks.”[1]

I debriefed DeMaw and ran down Rohde. I leveled with Lewellen and checked it all for grammar and its here, blinking at me. Let me switch to 20 Meters. See how the different LEDs light? Why didn't I put them on the panel? They make the circuit work better, while imparting their Electroluminescent Echo like my S-38 and the shadow its 35GT once cast on the wall. A Japanese customer called it “Tokyo at Night;” US hams call it a “Christmas tree.”

## Receiver Details

The shadow casting of old and new is a dual dual-conversion, dual dual-image, superhet SSB/CW receiver. The dual, dual-conversion means it has two switching first IF's, the frequency determined by the crystal filters, one at 4.000 MHz for 30/17 Meters (1st dual image), and one at 3.547 for 40/20 Meters (2nd dual image). The frequency difference between the filters is 455 kHz, which allows for the second conversion to a 455 kHz IF strip. A switching VFO makes it possible, with 14 MHz (30/17 Meters), 10.545 MHz (40 Meters), and 10.455 MHz (20 Meters) switched with Infrared devices controlled by the crystal filters.

Two varicap tuned bandpass filters filter the incoming signals [2]. One tunes 40/30 meters, the other 20/17 meters. A 2N5109 type RF amplifier is included for additional gain in antenna restricted areas

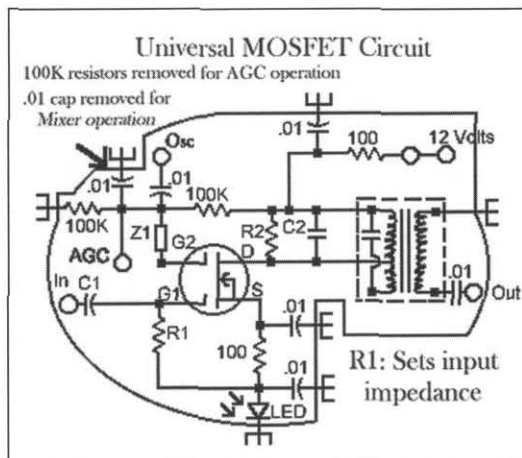

Figure 1—The basic LED MOSFET circuit diagram.

or with high-loss low-noise receiving antennas [3].

As most people build it, you get a 150 kHz bandspread set in the lower CW portions of 40 and 20 Meters, and 180 kHz bandspread (14 MHz VFO) to cover the 30/17 Meter bands.

A crystal oscillator is switched with the crystal filters to always give 455 kHz out of the second mixer to the AGC controlled 455 kHz IF strip. Finally, it goes to a Schottky diode product detector, fed with a variable injection BFO/BFO amplifier. Two audio amplifiers are used, the pre-amplifier with adjustable gain. Speaker output is 4 ohms, 8 watts, with a TDA2002 car amplifier chip.

The first prototype was the “LED MOSFET Receiver.” Later, from an article in *QST* [4], I discovered that the first LEDs were called “Electroluminescent Diodes,” so I dubbed the next version the “Electroluminescent Receiver.” At HamComm in Dallas, a sweet lady from NASA informed me there were no “electroluminescents” in the receiver. That name had been stolen from LEDs to be used for certain types of flat panel displays that she made for the space shuttle. Oh Well!

## Lights, Lights, Lights

The LEDs provide self-diagnosis, visual signal levels, switching indicators, and

wireless switching. The total is 21 LEDs, plus 5 IREDS. The five IREDS manage the band switching of the receiver, eliminating wires across sections of the receiver, improving isolation. The switching indicator LEDs can be changed to Super Bright LEDs, giving the builder options to increase the visual impact of the receiver for beauty or just plain fun.

The first vision of this receiver came when working on the 9 MHz strip of the Progressive Communications Receiver [5]. Hayward and Lawson used an LED to raise the working bias of the MOSFET amplifiers to eliminate a negative voltage for AGC. I found that the LED flashed along with the AGC voltage, and after building a bunch more, found the LED did an excellent job of diagnosing the circuit for mistakes.

The basic MOSFET circuit (Figure 1) is very adaptable. With only changes to Gate 2, the circuit can be configured as an amplifier, mixer, or AGC controlled amplifier. With the LED in the circuit, bias at Gate 2 is 6 volts for full gain.

The multiple functions of the MOSFET circuit allowed its use in every part of the receiver, except the oscillators, filters, product detector, and audio amplifiers. With the diagnostic function of the LED in the MOSFET circuit, a receiver that was nearly 100% self-testing was born.

Normal current through the LED is 5 mA, which yields a bright LED. If the LED is very bright, dim, or off, looking for a missed solder joint, wrong value resistor or a missing part will fix the circuit. To test the MOSFET, the output transformer is pulled while the circuit is powered. The LED should go off, if not, a bad MOSFET or a short across the transformer leads is the problem. All the amplifiers are self-diagnosed with this procedure.

The mixer LEDs (see Figure 2) perform two functions. They diagnose the mixer, but also give a visual indication of oscillator injection levels for fine tuning the operation of the mixers.

Since the Gate 2 bias is 0.5 volt, the LEDs are off with no oscillator injection. Oscillator injection turns on the LEDs,

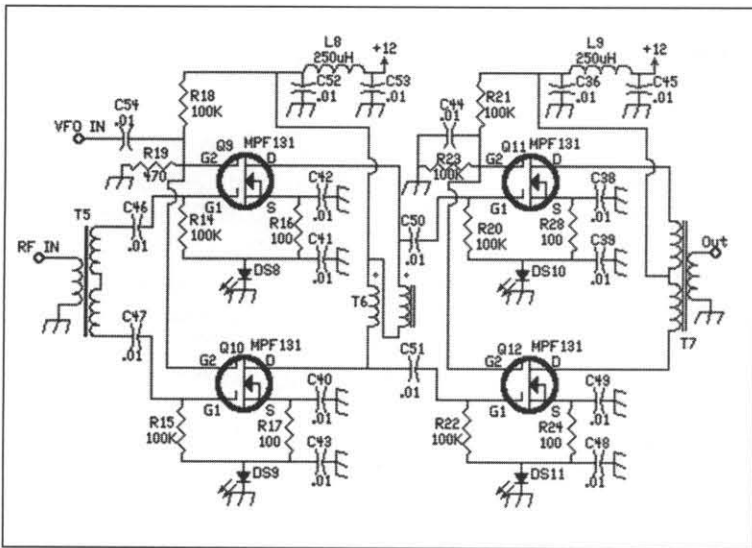

Figure 2—Mixer circuit with LED level indicators.

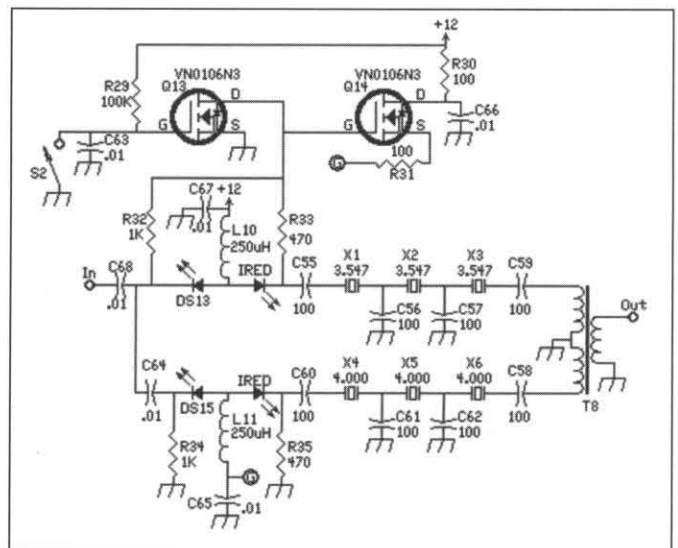

Figure 3—IR switching is used to select the crystal filters.

showing oscillator excitation and the level of the incoming signal. The VFO and Crystal oscillators are tested in this manner.

The first VFO amplifier has a "Gain Adjust" control. This control adjusts VFO injection level to the First Mixer. The level of injection sets the dynamic range/sensitivity of the mixer giving an adjustment for different antennas and band conditions.

Indicator LEDs are at the Crystal filter, Bandpass filter, VFO and the Crystal oscillator. The LEDs at the Crystal Filter, Bandpass filter, and the 10.545 VFO relay can be changed to Super Bright LEDs. Super Brights at the Crystal oscillator lower output, so regular LEDs remain here.

### IR Switching

The major innovation of this receiver is the use of Infrared devices to control switching of the receiver. The Crystal Filter is the control center. IR allows superior isolation of the sections of the receiver. The only wires that run between any sections of the receiver are B+ and signal lines. IR paths eliminate jumper wires across sections that intensify the birdies of the receiver.

One IR emitter, a high power IRED [6], at the 4.000 MHz Crystal Filter, switches the Crystal Oscillator with the Crystal Filters, so the output of the Second Mixer is always 455 KHz. A Phototransistor is used at the Crystal Oscillator, inside a switching circuit that, without any IR energy, turns on the 4.000 MHz crystal, and

with IR energy, turns on the 3.547 MHz crystal.

Another high power IRED switched on at the 3.547 MHz filter controls the VFO frequencies (see Figure 4). When this IRED is on (3.547 MHz filter is on) a Phototransistor is turned on that switches the 10.545 VFO relay, which turns on the receiver to 40 Meters.

This same Phototransistor gives power to a second 10.455 VFO relay, which is switched on by a Photodiode that is activated when the 20 Bandpass filter is selected. Another IRED is at the bottom of the 20/17 Meter bandpass filter, and is turned on when that NBPF is selected by the Bandpass switch. This action turns on the receiver for 20 Meter reception.

Another set of Photodiodes/IREDs is at the input and output of the Bandpass filters. An IRED located at the output of the filter is turned on by a switching circuit. This in turn turns on a Photodiode directly across from it, that turns on the input relay and the indicating LED. The switching circuit needs only one wire, when ungrounded the 40/30 Meter bandpass filter is on, and when grounded the 20/17 Meter bandpass filter is on. The IR devices eliminate jumper wires and improve the input/output isolation of the filters.

### The Hundred Schools

All the circuits in the receiver have a reference article (or many articles). Going even further, the Input board can be com-

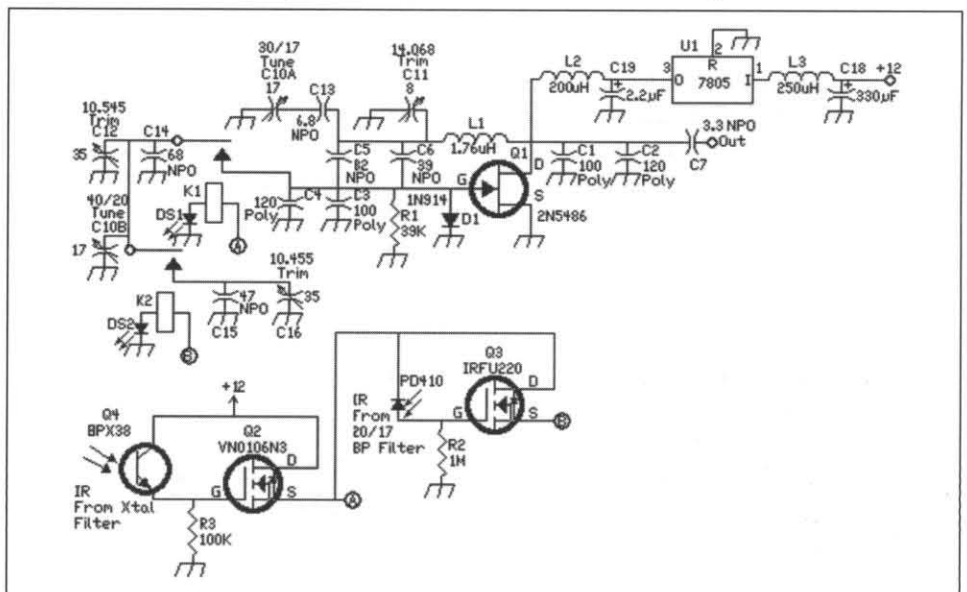

Figure 4—VFO and LED band switching circuit.

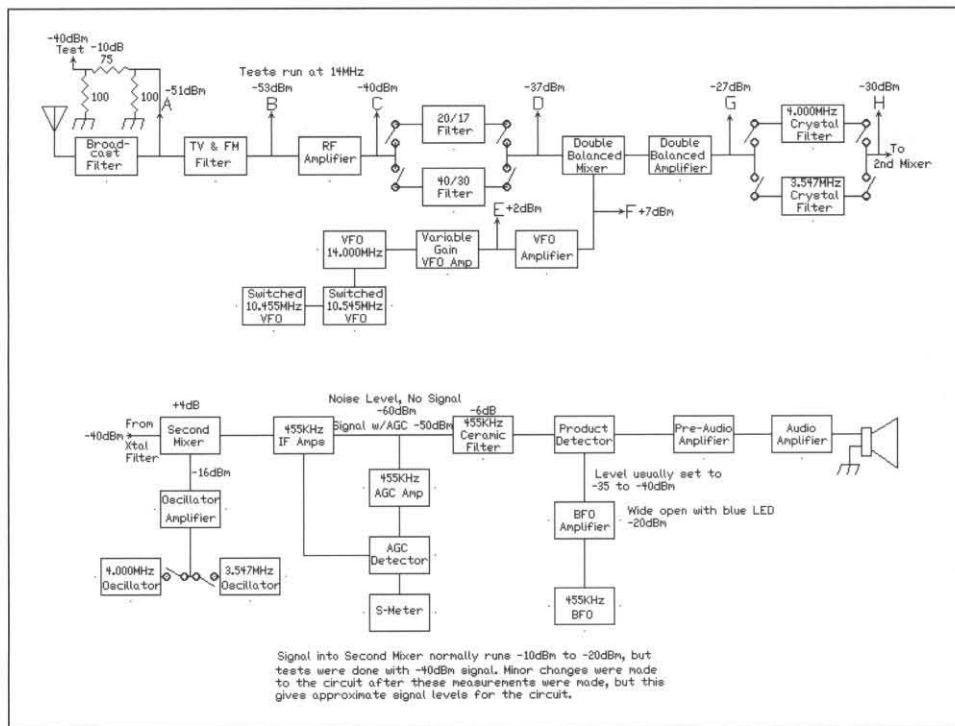

Figure 5—Block diagram of the Electroluminescent Receiver.

puter modeled. The input filters are from Sabin's *QEX* article [2], with all the information to work with the ARRL RF Designer program on the ARRL website [7]. The Serenade SV is used to model the 2N5109 type RF amplifier [8].

Each individual circuit stands out on the boards, identified by the silk-screen, with easy connections to the in/out ports. Each board divides into three sections, with a row of holes to help cutting or soldering shields. Each circuit in a section has very well defined in/out ports for easy tie-ins.

While stuffing the boards, each section is given uncluttered attention. Memorize the name of each section as you go. Then I would be surprised if you could not draw a block diagram of the receiver after building the kit, visualizing the layout of the boards.

A CD-ROM was chosen for the manual. The circuit details are 50 pages, and there are an additional 50 pages for the detailed building instructions for the kit. A CD-ROM gave the freedom to include pictures (225) as needed to explain the circuits and instructions.

### Conclusion

I would have never taken a multi-band superhet receiver to market without some way to diagnose almost all the circuits. The LED MOSFET circuit made the day in this respect. With 99% of all mistakes due to soldering error, the LEDs will point where to look.

The LEDs are actually a crude "oscilloscope," giving a visual look inside the receiver by turning electrical current into light. It looks good, but it also has meaning.

Excitement while working with a circuit gives the impulse to learn. Only a handful of CD-ROMs from the ARRL, a Ham Radio CD-ROM, and some copies of ARRL Handbooks give plenty of reading material on this receiver to challenge even the most curious. That perks interest in other circuits, claiming better performance. Then the receiver never stops changing.

Being awake during the building process should teach the layout of the receiver, then a working receiver is there for use as a base for experimenting and learning. You might suddenly discover that you are

not far from building an Ultimate receiver of your own design.

### Footnotes:

1. The receiver is \$89.95 plus shipping. Options are a "Huff & Puff" stabilizer (\$20), and an AADE Frequency Counter (\$58.95) To order go to <http://www.nwtexas.com/usr/r/receivers/elrorderinfo.htm>, or mail to David White, P.O. Box 71, Pampa, Texas 79066-0071. Receiver web-site address: <http://www.nwtexas.com/usr/r/receivers>

2. The inspiration for these filters came from "Narrow Band-Pass Filters for HF," by William Sabin, Sept/Oct 2000, *QEX*.

3. The receiver was designed to work well attached to a ham stick inside of a condo/townhouse window. The RF amplifier is the post-mixer amplifier of the Progressive Communications Receiver, but with a 2N3019 in place of a 2N5109.

4. "Electroluminescent Diode: a p-n junction device which takes electrical current and voltage and changes it directly to light." (*QST*, July 1974, page 62.)

5. Wes Hayward, W7ZOI, and John Lawson, K5IRK, "A Progressive Communications Receiver," *QST*, November 1981, Page 11. On the Internet, check out <http://www.qsl.net/aa3sj/Pages/Prog-receiver.html>

6. <http://www.bgmicro.com>; individual IREDS are part number LED1067, Page 8. (T-1 fl", 1.3V, 1A peak, 100 mA continuous, 940 nm, 16 degree viewing angle, clear package). The ones in the kit are smoked package, but these are similar in specs and recently replaced the smoked colored ones in their Illuminator kit.

7. NBPF.ZIP at <http://www.arrl.org/qex-files> has all the information for inputting the files into the ARRL Radio Designer program.

8. The information on using the program for the 2N5109 is "Simulating Circuits and Systems with Serenade SV," by David Newkirk, W9VES, January 2001, *QST*, Page 37. The file for the RF amplifier is SerSV0101.ZIP at <http://www.arrl.org/files/qst-binaries/> The Ansoft Serenade SV can be downloaded at <http://www.ansoft.com/about/academics/serav/index.cfm>. The student version is free. ●●

# Ramblings of a Displaced Cajun Lad in Maine

Joel Denison—KE1LA

hamjoel@juno.com

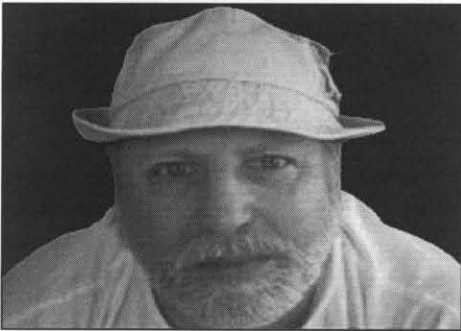

**D**one ah evah told u 'bout the trip me, Alphonse, Clovis Thibideaux, Pierre Fontenoit, and Clarence Melancon done took last fall in Vermillion Bay, Louisiana...?

We done decided to geaux to the island just on the other side of de southwest pass what goes by Marsh Island...what a trip...

We used Clovis fishing boat...a big twenty-footer, flat bottom, to tote us out thair and back...Pierre and Clarence, they come along to help and play cw...

When we gots to the island, we found a place to set up tent and start to looking for the two forty-foot pole what we done brought with us...we was gonna put up a big doublet and fed it with twinlead to a chuner and some altoid tin xceivers...

Man we was proud...big comffy tent, with skitter bar...bout ten different xmtrs to play with...a few vertical antennas we brought to play with the salt water grounding...we even remembered to brought the kite... to hang up a long wire...

U see...whare we was, the wind blow all day and all nite...one direction during the day, and the utter direction during the nite...

What we didn't figure on was the 'lectric shock that long wire pick up with the wind...knock peaux Clarence across the

marsh like he be a dead crab, I tell u, Man... terrible sight..Clarence's eyeballs glowed all nite...

Clovis and Alphonse got them heads together and went took one of the sparking plugs off the outboard motor and connect it to the antenna wire...what a relief that was... that ole plug just arked away and kept the antenna volt down to a light shock...

They also tied a piece of cloth to the end of the wire, put a rock in it for weight, and was proud of theyselves as they had made an anchor 'case the antenna got itself loose and started 'cross the bay or the gulf...that way they could catch it with the boat and bring it back...

Things gone good till bout three in the morning when a thunderstorm come up and blowed away the long wire antenna...

A sight to see, I tell u...that cloth just under water dragging behind the antenna and headed towards South America...

Clovis hollared at Alphonse to grab the sparking plug we had ban using on the antenna, and brought it to him as he had no spares...

Alphonse him, he just stood ther looking at the antenna and it's sea anchor... Alphonse said, "Clovis u kneaux ah can't swim that good and that sparking plug be tied to the antenna..."

Clovis him he started the motor and it run, but not good enough to geaux chasing a kite in the gulf...so we decided to just let things be and hobble into land on one plug when we decided to left...

Things calmed down sum till bout noon the next day...heck we had only lost one vertical to a direct lightnin' hit...three altoid tins (xceivers) to two alligators...one longwire antenna...and of course, the

sparkling plug for the boat motor...

For us, this be a fairly uneventual trip... 'Bout noon though...we seed the kite coming back on the opposite wind...sparkling plug still attach...

Clovice and Alphonse jump in the boat and started chasin' that antenna with one spark plug...after bout an hour, they caught the thing, retrived the plug, and come zooming back to camp...

Wow, Man, someone broke open the last keg of kick-a-poo juice and we celebrated...we even put sum out for the alligators...they (the gators) sure walk funny after a few sips of that stuff...

Bout four that evening, Pierre him, he come into camp and say... "don' we need half a tank of gas to got ourselves back to the landing...?"

"Sheaux nuff," say Clovis..."what be the problem...?"

Pierre, he say, "Chasin' that utter sparking plug like u did u burn up three quarters of the gas...what we gonna do...?"

It was decided that Clovis and Pierre would geaux to the game warden's camp on Marsh Island, just down the bay...and got some gas from them...and while they be gone the rest of us gonna pack...

Well, we packed and waited, fed the mosquitoes, and finally they two come back with the boat...that had a full tank of gas...they had also showered, eaten a big seafood dinner, watch a bit of TV with the wardens and then remembered about us...

So we loaded up and went back to the boat landing...

The moral heah being...be prepared, and brought lots of food and extra sparking plugs...

—de KE1LA Joel in Maine...freezin' ●●

## Email Reflector for Volunteer Examiners

Please note that there is an email reflector available that serves VEs called 'USVE.' It's been in existence for over two years now, and although it's currently going strong, it can always use new members.

The main purpose of this email reflector is to serve as a forum for all VEs working under any VEC in the U.S., and it's

a place where they can exchange ideas on running test sessions and sort out procedural questions as it pertains to both running and organizing test sessions and ham radio classes.

Signup is easy, just send a blank email to [usve-subscribe@yahoogroups.com](mailto:usve-subscribe@yahoogroups.com). Members can post a message to [usve@yahoogroups.com](mailto:usve@yahoogroups.com). Thanks very much!

—information via Joe Wonoski, N1KHB

# The QuickieLab

## A BASIC Stamp Platform for Ham Radio Experiments

George Heron—N2APB

n2apb@amsat.org

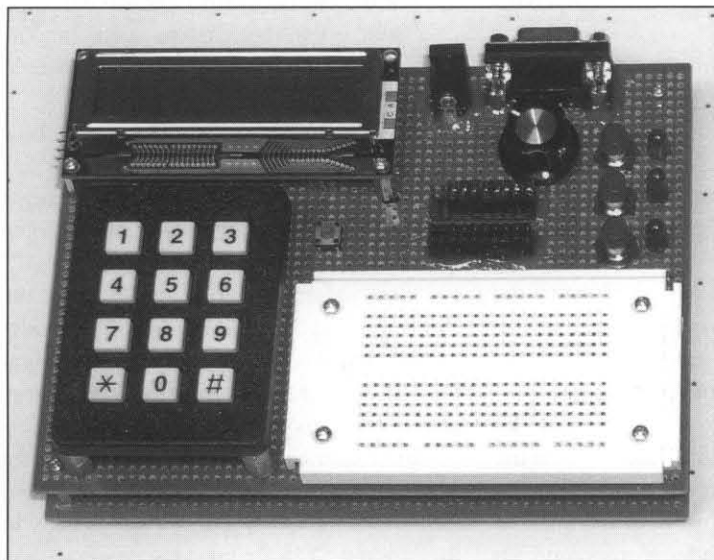

**Figure 1—The QuickieLab is a BASIC Stamp-powered experimenter's platform with a 16x2 character LCD for data and status display, keypad for numeric data and command entry, general purpose input/output devices (potentiometer, pushbuttons, LEDs, speaker), a frequency counter, A/D and D/A converters, a digital pot and an RS-232 serial port for downloading of Basic program experiments. Provision is also made to accommodate the new AD9850 DDS DaughterCard from the HC908 Digital Breadboard project! The Stamp's sixteen input/output pins may be jumpered over to a reusable plugboard for temporary addition of circuit components that, in conjunction with the microcontroller itself, work with the downloaded software to perform the experiments.**

Great feedback is regularly received now from readers on the latest string of microcomputing projects in the Digital QRP Homebrewing column, the Micro Moments segments in Information Exchange, and even in the Test Topics and More column by N2CX. It's very gratifying and encouraging to know that many QRPers are interested in these digital projects.

When considering additional useful projects that readers can easily build right now, the light bulb clicked on once again during a discussion over lunch with Joe Everhart, N2CX. We decided then that a perfect project would be one that provides a reusable test bed for experimentation, measurement and simple control. Further, we thought it be great if this experimenter's platform were tightly coupled with the string of "N2CX Quickies" presented here in each issue of QQ. This would provide Joe with a computing module to help illustrate his points and the readers with a quick and easy way to reproduce the Quickie material. Hence the name of this project was born ... the QuickieLab.

### The BASIC Stamp

The QuickieLab is a 4.5" x 6" circuit board with keypad, LCD,

switch input and LED output capabilities built around the popular BASIC Stamp processor from Parallax, Inc. The Stamp was selected because of its easy to program BASIC language and its simple hardware interface—just connect +5V to this Stamp chip and you can download a BASIC program from your PC to wiggle the output pins and read the input pins as desired.

Readers wishing to follow along with N2CX and his BASIC language experiments could certainly purchase one of the many fine Stamp-based experimentation boards from Parallax.com and have a ready-to-go hardware platform with most of the capabilities described here. However, one could save quite a few pennies by building the QuickieLab from the plans in this article and end up with a more capable platform that is specifically geared to the Joe's Quickie experiments coming in future installments.

Referring to the schematic in Figure 2, you can see that the QuickieLab is built around a BASIC Stamp microcontroller.

The Stamp merely needs to be powered with 6-to-12 VDC from the QuickieLab's connector J1 and this self-contained "system on a chip" is ready to go. It contains an onboard 5V regulator for its computing logic and its own RS-232 levels for serial port connection to a PC. Further, the Stamp contains an internal non-volatile memory that allows retention of the software program even after power is removed. With this capability the QuickieLab can be programmed once (i.e., its software program needs only to be downloaded once from the PC), and it can forevermore operate independent from the PC umbilical cord. Take it out to the field with an appropriate battery supply or to your buddy's house and it'll operate the same as it last did on your bench!

### I/O Pins Do All the Work

The main purpose of any microcontroller is to input various signals, do some computations based on those signals, and then output other signals based on those computations. Thus the Stamp's 16 I/O pins are of great interest and utility to us in the QuickieLab. Each of the I/O pins is under software control and can be used to read the state of pushbuttons and keypad actuations, as well as to send data to human-readable devices like the LEDs and the LCD. The I/O pins are wired to a jumper block J10 located directly above the plugboard and the user may jumper any of them to components placed on the plugboard. In this way, the components called out in the experiment may be temporarily "wired" to the Stamp and controlled by the software program. For example, you could mount a diode, resistor and a couple of capacitors on the plugboard, jumper the output of that network to the built-in A/D converter (see following section) and have yourself a rudimentary-but-useful RF voltmeter. Of course you'd have to have the Voltmeter software loaded on the Stamp from the N2CX Quickie website—Joe intends on having many such software programs and application notes available for the QuickieLab.

As mentioned, a number of common I/O devices are provided on the QuickieLab board for use in the various experiments. Three

pushbuttons and three LEDs are provided for simple input and output controls and indicators. Sometimes the most instructive experiment is to press a button and see a corresponding LED be illuminated under program control. A built-in potentiometer is provided and is quite useful as a control that delivers a continuously variable 0-255 binary input to the Basic program. A program can read the pot and adjust a software algorithm based on the specific setting. A simple D-to-A converter is provided to produce a DC voltage from 0-to-5V for controlling other hardware under software control. And lastly, a speaker is provided to enable the Basic program to output an audio tone that can range from 200 Hz up to 10 kHz. Can't you just imagine a an upcoming Joe's Quickie application using this speaker to produce an audio dip when measuring SWR?!

Each of these built-in I/O devices is wired to a specific I/O pin of the Stamp through pinheader P1. When the corresponding pins of P1 are jumpered with configuration blocks, the respective signals are wired directly to I/O pins on the Stamp. In this way you could easily configure the QuickieLab to use its built-in components for experiments without necessarily using additional components on the plugboard. When a given built-in I/O device is not needed for the current experiment, its pins on P1 can be left open and the Stamp's I/O pin on J10 may be jumpered over to something else on the plugboard.

### **I/O Expander**

Perhaps the most attractive feature of the QuickieLab, as compared to commercially-available Stamp boards, is the custom-designed I/O expansion processor U2. Readers of the Digital QRP Homebrewing column in QQ will recognize the SX-28 microcontroller used for I/O expansion here as also being used in the PSK31 Audio Beacon and Badger smartbadge projects. This time I programmed the SX-28 to enhance the QuickieLab by having it serve as an intermediate processor that helps in the input and output of some additional built-in components. The Micro Moments segment in the Information Exchange column provides complete details on interfacing and using the I/O Expander, but here's a quick overview of the function provided in this versatile controller.

*Serial LCD Display Driver*—The SX-28 accepts serial commands from the BASIC Stamp to display the specified ASCII character directly, or a command character to control the cursor position and other LCD functions like clear display and scroll control. The SX-28 duplicates the simple command structure found in other "serial LCD" controllers, allowing the QuickieLab programmer (i.e., you) to easily display messages to the LCD display. You can clear the display, home the cursor, control scrolling and blinking, and simply display characters all by means of a serial output command from the BASIC Stamp software you've written.

Further, there are some "canned messages" that ease the effort of programming the QuickieLab. For example, a command can be issued to the SX-28 to display useful messages like "Voltage = " and "Frequency = ."

*Frequency Counter*—Another unique feature of this I/O Expander chip is its ability to measure frequency. Since this fast SX processor is sitting idle most of the time waiting to be commanded by the Stamp to display characters, I dropped in a tried-and-true software routine that samples the signal on the RTCC pin and determines its frequency. Thus when the Stamp commands a frequency measurement, the SX processor sends back certain data that represents the frequency of the input signal up to 30 MHz. This is a pretty useful feature for a QuickieLab such as ours!

*A-to-D Converter*—Since it is important in most of our ham experiments to read an analog voltage of some sort, we felt it would great to add a simple 8-bit A/D converter as part of the built-in arsenal of components. The I/O Expander interfaces to the ubiquitous ADC0831 chip and the BASIC program in the Stamp can issue an ADC command instructing the analog conversion to be done. The 8-bit value is then returned to the Stamp controller for possible computation and display.

*Keypad*—Yet another important I/O component contained in the I/O Expander chip is that of the software driver and hardware interface to a keypad. Useful for numeric and command entry, this 4 row x 3 column matrix keypad is constantly scanned by the SX controller. Whenever a keypress is detected, a message is sent to the main BASIC program in the STAMP controller and specific action can be taken.

In this way, the programmer (i.e., N2CX with his application note software, or you with your own software experiment) may input data, set frequencies to be later output, etc.

*Digital Potentiometer*—The final built-in I/O device controlled by the I/O Expander is a non-volatile "digital potentiometer." This device is essentially an electronic pot that can be adjusted under program control to move its wiper to be at any of 100 positions. If, for example, this digital pot were jumpered into the feedback loop of an op amp on the plugboard, your BASIC Stamp program could output a command to the I/O controller to adjust the pot up or down to change gain of the amplifier stage. This is a pretty neat capability to have in our experimenter's platform!

*DDS DaughterCard*—Provisions are made on the QuickieLab to accommodate the newest addition in the HC908 Digital Breadboard project family—a DDS daughtercard. This small board contains the AD9850 Direct Digital Synthesis chip, its oscillator and the low pass output filters that all conspire to produce very precise and low-noise frequencies from the subhertz basement up to 30 MHz. The 1" x 1" daughtercard plugs into socket J6 on the QuickieLab and enables the homebrewer/programmer to generate a very stable and known-frequency signal source. It can be useful as a VFO, a test signal source, a local oscillator in a test receiver or even as an audio oscillator when patched into the built-in speaker on the QuickieLab.

### **Construction**

Building up the QuickieLab is a piece of cake. A partial kit of parts (pc board and programmed SX-28 I/O Expander chip) is available to help homebrewers build up a QuickieLab. Alternatively, one could easily wire up a perf board containing the few chips and connectors comprising the project. A parts list is provided in the Notes section at the end of this article to enable homebrewers to easily acquire the parts and construct the QuickieLab.

The prototype QuickieLab pictured in this article was constructed on a 4.5" x 6" piece of perf board. The keypad and LCD modules are held up off the board with standoffs and plug into connectors on the perf board to facilitate easy access to components beneath them during the construction and test phases. The SX-28 controller,

voltage regulator and A/D converter chips are located under the LCD, and the BASIC Stamp chip is located under the keypad. The pushbuttons, LEDs and potentiometer are located in the upper right portion of the board. The DB9 serial connector, and DC power jack are located in the upper center area, while the plugboard can be seen in the lower right corner of the perf board. The female socket J3 containing the Stamp I/O pin signals is located directly above the plugboard to allow the user to easily place a wire jumper from any given signal in J3 to a component placed on the plugboard. Pinheader P3. Jumpers to select the built-in IO devices are located right above the STAMP I/O pin signals connector P3. The speaker is attached to the underside of the perf board. A second perf board with identical dimensions as the main board is connected beneath the main board and separated using eight standoffs. This serves to protect the underside wiring of the QuickieLab. Rubber feet are attached to the bottom perf board to allow it to stand comfortably on your work table when in use.

### Using the QuickieLab

The QuickieLab is first and foremost based on the BASIC Stamp. The vendor of this ingenious device (Parallax.com) provides an excellent development suite to support hobbyists in their programming and use of the Stamp. When you purchase the microcontroller from Parallax, you can request a CD-ROM containing software for your PC that allows you to create/modify your BASIC programs and download them to the Stamp contained on the QuickieLab. Otherwise, all software contained on the CD-ROM is also available for free download from their Stamp web pages at [www.parallax.com](http://www.parallax.com). Their "PBASIC" commands are tailored to realtime control of simple hardware devices and there are many useful extensions to the language which are of great value to homebrewers. The CD-ROM also contains many sample programs illustrating basic operation of the commands and chip features. A Users Manual is provided in PDF format on the CD to guide first time users through typical BASIC program creation and debug sessions. A complete PBASIC language guide is also in the Users Manual for detailed use as a programming reference.

With all this neat development stuff

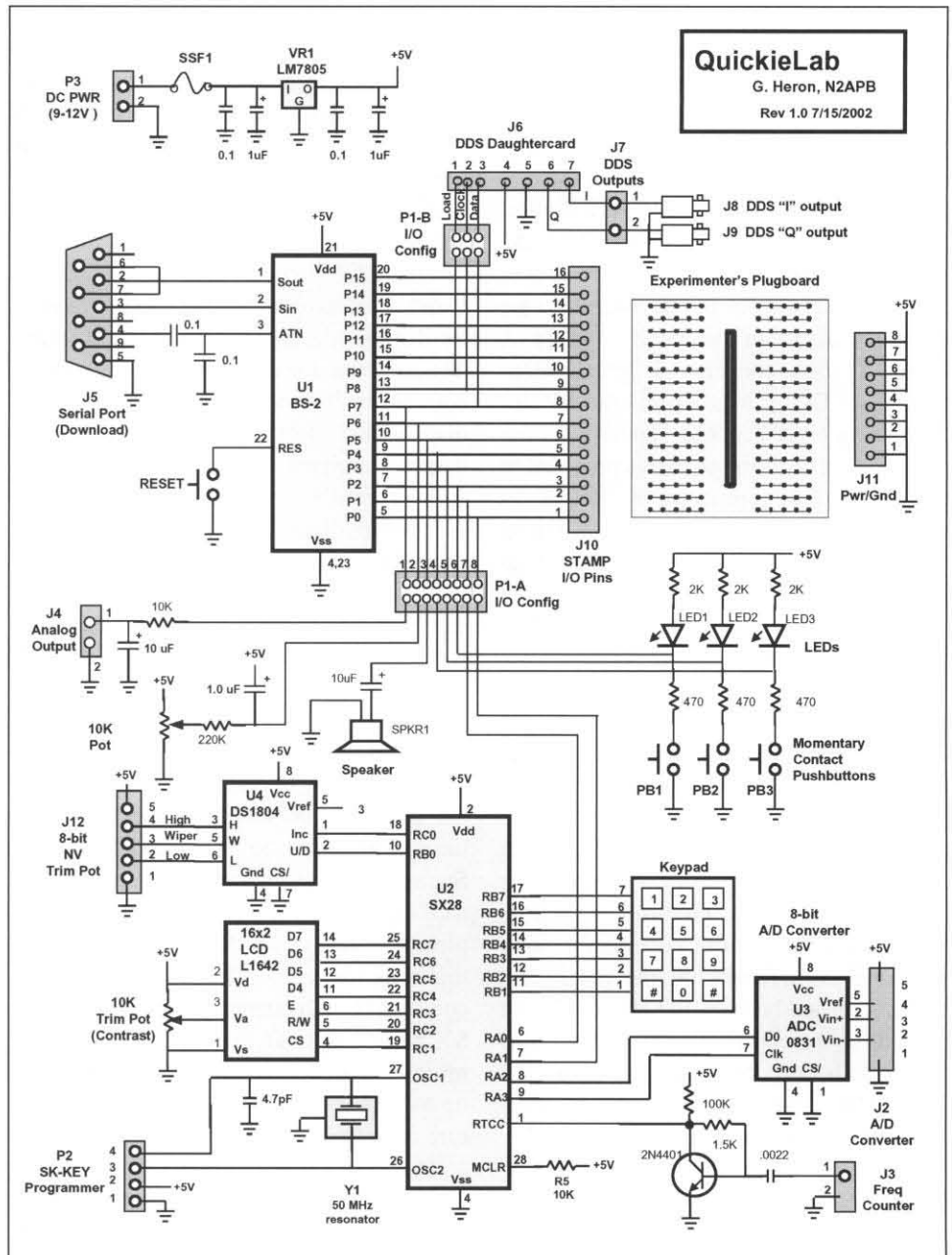



U1 BASIC Stamp — [www.parallax.com](http://www.parallax.com)  
 U2 I/O Expander, Y1 resonator & PCB — NJQRP Club  
 U3 — A/D converter, Digi-Key ADC0831CCN-ND  
 U4 — NV Trim Pot IC, Digi-Key DS1804-100-ND  
 LCD — 16x2 character, Seiko L1642, [www.eio.com](http://www.eio.com)  
 Keypad — 4 row x 3 column, Digi-Key GH5001-ND  
 Plugboard — Radio Shack 276-175  
 Perf Board — Radio Shack 276-1396A  
 J5 — RS-232 conn., D-style, Jameco 104951  
 P3 — 2.1 mm coaxial power conn., Mouser 163-5004  
 J8, J9 — BNC jacks, Mouser 523-31-5538-10-RFX  
 VR1 — 1A 5V regulator, Mouser 511-L7805 ABV  
 Heatsink — Mouser 532-577102B00  
 SSF1 — Solid State Fuse, Mouser 652-MFR050  
 PB1,2,3 — Pushbutton (3), Mouser 103-1022  
 Reset Pushbutton — Jameco 149948  
 J2,3,4,6,7,10,11,12 — SIP sockets, Mouser 517-974-01-36  
 P1 — 2x12 pinheader, Mouser 517-6121TN  
 Jumper shunts (16) — 0.1", Mouser 571-3828155  
 Speaker — 32-ohm, Mouser 65-AT-42  
 Q1 — 2N4401 transistor, Future-Active 2N4401  
 LED (3) — Digi-Key 160-1104-ND  
 Capacitor — 4.7 pF disc  
 Capacitor — .0022 uF disc  
 Capacitor — .1 uF mono, Future-Active SR215E104MAA  
 Capacitor — 1 uF electrolytic, Mouser 140-XRL50V1.0  
 Capacitor — 10 uF electrolytic, Mouser 140-XRL16V10  
 IC socket (2) — 8-pin, Mouser 575-193308  
 IC socket — 24-pin, Mouser 575-193324  
 IC socket — 28-pin, Mouser 575-193328  
 Potentiometer — 10 kohm, Mouser 31CW401  
 Trim Pot — 10 kohm, Mouser 72-T93XA-10K  
 Resistor — 470 ohm resistors (3) - Mouser 291-470  
 Resistor — 1.5 kohm Mouser 291-1.5K  
 Resistor — 2 kohm, Mouser 291-2K  
 Resistor — 10 kohm, Mouser 291-10K  
 Resistor — 100 kohm, Mouser 291-100K  
 Resistor — 220 kohm, Mouser 291-220K

#### Parts list for the QuickieLab.

The QuickieLab is not a performance-oriented or extensible microcomputing platform. A very limited number of I/O pins limits how many hardware components can be connected at one time. Further, the effective speed of the Stamp is significantly slower than the HC908 Digital Breadboard project or any other native-language PIC processor, mainly because the Stamp interprets its high-level BASIC commands individually at run time, greatly slowing down its overall computing process. In contrast, the HC908 Digital Breadboard project is a far better choice for a flexible and dedicated high-performance control and measurement piece of equipment for your bench.

However even with these limitations, the QuickieLab is a great educational solution for quick-and-easy experiments that don't require lots of high speed operations. N2CX regularly tells me how utterly cool it is to be able to program an algorithm into the QuickieLab and see immediate results.

Any way you look at the QuickieLab, it's easy to build, fun to use and you can bet that we'll be seeing lots of applications for it in future "Joe's Quickies." And for starters, have a go at the "Audio Voltmeter" application elsewhere in this issue!

#### NOTES

1) The QuickieLab project website can be found at [www.njqrp.org/quickielab](http://www.njqrp.org/quickielab). It contains more detailed construction and test information, color photos, I/O Expander source code, BASIC Stamp sample programs, QuickieLab application notes, and a complete listing of I/O Expander commands and control characters.

2) A QuickieLab p.c. board (\$25) and programmed SX-28 I/O Expander chip (\$15) are available for sale from the NJQRP Club. Write check or M.O. payable to "Dave Porter, AA3UR" and send to 647 Middle Holland Rd, Holland, PA 18966. Electronic payment is also accepted via PayPal to [njqrp-kits@comcast.net](mailto:njqrp-kits@comcast.net). Prices indicated are postpaid for US & Canadian orders. DX orders please add \$5.

3) Read all about the BASIC Stamp at the Parallax.com website ([www.parallax.com](http://www.parallax.com)). All software, application notes and documentation are free for the download, and great fun can be had while perusing this vendor's website.

4) Information concerning the HC908 Digital Breadboard project referenced in this article can be found at [www.njqrp.org/digital-homebrewing](http://www.njqrp.org/digital-homebrewing) ●●

#### Product Announcement—

#### 2002 Christmas Key from Morse Express

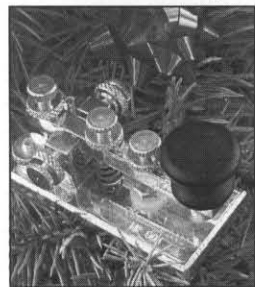

In what is becoming a ham radio Christmas tradition, Morse Express has released its 2002 Christmas Key, a gold-plated miniature brass telegraph key which will double nicely as a Christmas tree ornament.

The Morse Express Christmas key is a fully operational miniature key, hand-machined from solid brass and plated in gold. It measures a tiny 2-3/8" by 1-1/8" at the base and weighs a surprising five ounces.

According to Marshall Emm (N1FN) at Morse Express, the 2002 Christmas Key incorporates several improvements over the 2001 key, including miniature binding posts for cable connection, chased wiring on the bottom, and an ebony knob.

The base of each key is engraved with

Morse Express' "Speedy Key" logo and "Christmas 2002." This is a limited edition of 250 keys, and each bears an engraved serial number on the base.

The 2002 Christmas Key is \$59.95, plus S/H, and is available only from Morse Express. Pictures and more information are available on the Morse Express web site at [www.MorseX.com](http://www.MorseX.com) where you will also find secure ordering facilities.

Call (800) 238-8205 toll free to order by phone, or (303) 752-3382 for more information. ●●

# QRV? The Ubiquitous Cathode Ray Tube

Mike Boatright—KO4WX

ko4wx@mindspring.com

Last time in QRV?, we talked about designing a bandscope that would allow us to see the relative strength of signals across a selected range of spectrum—otherwise known as a spectrum analyzer. We saw how you can build a signal strength receiver using a voltage controlled oscillator and came to the conclusion that we needed a cathode ray tube and a ramp generator to complete our bandscope.

The cathode ray tube—or CRT—is at the heart of one of the most useful pieces of test equipment you can have on your bench—the oscilloscope (oh, and it's also used in that consumer thingy called the TV set). In this article, we'll talk about some of the technology core to this device and how it can be used to plot a picture of the piece of spectrum we're interested in seeing.

## Beam Me Up Scotty...or...now a pause for some Quantum Mechanics

Have you ever seen one of those "lightening globes" that they sell in boutique gift shops? You know the kind. There's a small sphere in the center and jump off and spark across to the inside surface of the globe? Strange as it may look, that globe is nothing more than an uncontrolled cathode ray tube, with a little bit of air in it.

The basic principles behind a cathode ray tube start with a little quantum physics. Now, I'm a computer nerd, not a quantum physician or mechanic, so bear with me. As I understand it, if you take two pieces of metal and put them in a vacuum, heat one of the pieces of metal and give it a negative electrical charge (call this the cathode), and make the other one positively charged (call it the anode) with respect to the first piece of metal, a current will flow between them. This is the basic principle behind the vacuum tube (Figure 1).

A cathode ray tube is a special kind of kind of vacuum tube. The tube is designed so that by changing various electrical or magnetic fields, you can direct a beam of electrons (call the cathode ray) onto a particular point on a piece of glass (called the screen) covered with phosphorescent material. Phosphorous and other materials like it have the interesting property (again described by quantum mechanics) that

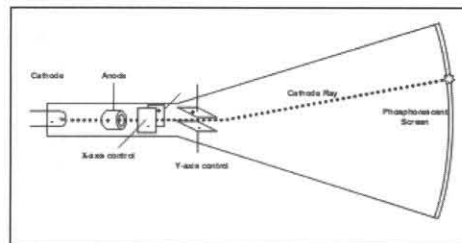

Figure 1—The basic CRT.

when struck by a stream of electrons, it glows. So a beam directed at a particular point on a screen coated on the inside with phosphorous or some other phosphorescent material will cause the material to glow at the precise point where the beam strikes the screen.

This is where the fun begins! Remember that electrons are attracted to a positive charge, and repelled by a negative one (that one goes way back to high school science)? In a CRT, the anode, which is positively charged, is specially designed so that the electrons being spewed out by the cathode are attracted towards, but never quite reach it, instead, continuing on in a fairly well focused beam. This beam travels towards the phosphorescent screen between two sets of plates, one set arranged vertically and the other horizontally.

If you make one of the plates more positive, and it's partner more negative, the beam will bend towards the positive plate. Do this in both the horizontal and vertical planes, and you can make a fairly precise placement of the beam at just about any desired place on the screen. (A side note, here, many CRTs today use magnetic coils to deflect the beam, but the principle is basically the same).

## Beam me up, or beam me across

The voltages necessary to generate the electron beam, focus and control its placement on the screen are extremely high—much higher than most QRP operators are comfortable with having floating around the bench. In most devices employing a cathode ray tube, special circuitry amplifies input voltages to those necessary to drive and deflect the beam. Regardless of the input levels, however, the basic idea is that

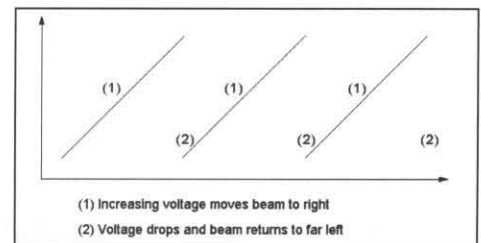

Figure 2—Sawtooth (ramp) waveform.

you increase the voltage on the X-axis control, and the beam moves from left to right (decrease moves it right to left), increase the voltage on the Y-axis control and the beam moves up (decrease moves it down).

Now, I need you to think multi-dimensionally for just a moment. Remember how we varied the frequency of a Voltage Controlled Oscillator in a ramp fashion? Imagine if we were to take this same idea and vary the voltage of the X-axis control in a ramp shaped exactly the same way, while keeping the Y-axis control voltage fixed? What would happen? ...long silent pause..."I know, I know!"

What would happen is, the beam would travel across the screen in a straight line, then stop. Not much use, is it? In fact, depending on how fast you varied the voltage, you might see a series of dots traveling across the screen, or you might see a line (possibly a flickering line) for just a brief instant. But try this: once the beam gets to the far right hand side of the screen, drop the voltage back to the value it takes to deflect the beam all the way back to the left (see Figure 2). Wait a few milliseconds while the circuitry catches up, then start ramping the voltage back up to the value it takes to deflect the beam all the way right. Do this over and over again, and what do you have?

Well, because the phosphorescent screen doesn't immediately stop glowing once the beam moves away from a particular point on the screen, and because the human eye cannot detect motion faster than about 1/30th of a second, what ends up happening is, you get a straight line traced across the screen. In reality, the beam is tracing from left to right, then returning to the far left and doing it over

and over again, but what you see is a straight line.

Let's take this one step further. At precise points along the line—you can figure this out by knowing sweep rate or number of sweeps of the X-axis in a second, and the amount of time you have to wait for the beam to return to the left before you can start tracing again—set the Y-axis control voltage to a value that corresponds to the signal strength that you measured at a particular frequency across a particular slice of bandwidth. Do this at various intervals—a process called sampling—and what do you get? Why, what you get is a graph of signal strength vs. frequency—what we were looking for in our bandscope (spectrum analyzer), all the time!

### Making it a Clean Sweep

Can you pat your head and rub your tummy at the same time? Yes or no, it's time to put on your thinking cap for a second. Remember from the last article that sweeping a VCO over a fixed portion of spectrum, sampling the signal strength, and plotting the results can make a bandscope. And now we've shown that by sweeping a cathode ray across an X-axis and setting to the Y-axis voltage to correspond to the signal strength at that point in time we can plot the results.

So obviously, the key to making our bandscope is to find a circuit that will sweep a voltage over time. We call this circuit—one that sweeps the VCO control voltage and the X-axis at the same time, a time base. You would think that this circuit would be very complicated, but fundamentally, is really pretty simple—and I alluded to it in the last article in a sneaky kind of way.

When you apply an electrical charge to a capacitor, there is a sudden inrush of current as the plates of the capacitor charge up. Once fully charged, no more current will flow into the capacitor (actually, the it never fully charges, but at some point the current flow becomes immeasurably small).

Look at Figure 3. If you charge that capacitor through a resistor, it will take longer for the capacitor to reach full charge, because the resistor limits the amount of current that can flow into the capacitor. The amount of time ( $t$ ) that it takes for the capacitor to charge to a certain amount (approximately  $2/3$ ) is called the time constant, and can be calculated from the for-

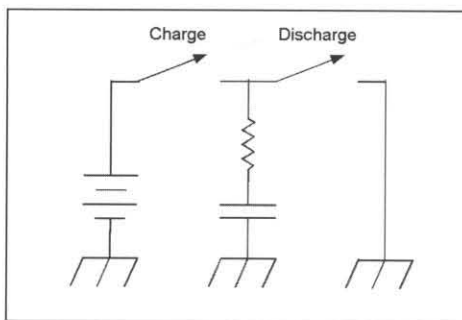

**Figure 3—An RC charge/discharge circuit for generating a ramp voltage.**

mula,  $t = RC$ , where  $R$  is the resistance in ohms and  $C$  is the capacitance in farads. It is interesting to note that this same time constant applies when the capacitor is discharged through the resistor.

Just about everyone is familiar with the NE555 timer integrated circuit. This ubiquitous little device can be found working as a tone generator, the tachometer in a car, DC-to-DC converters, servo system controllers—it can be found just about everywhere. Why? Because the Philips engineers that designed the chip figured out a way to control—within the IC—the charging and discharging switches (as shown in the diagram) such that very complicated timing signals (ramps, pulses, delay-pulses, etc.) can be constructed with very few external components.

Basically, the only things that you need to add to a NE555 timer are an external resistor and an external capacitor ( $R$  and  $C$  from above, and in Figure 4). The IC has pins that detect the voltage on the capacitor (THRESHOLD), control the voltage to charge to or discharge from when reached (CONTROL VOLTAGE), a reset the switches (RESET), a path to ground to discharge the capacitor (DISCHARGE), a

triggered output signal (OUTPUT) and a pin to trigger the device (TRIGGER).

It is amazingly simple. When configured for monostable operation, a ramp-like waveform appears at the R/C connection. In this configuration, the reset is held high, forcing the device to charge  $C$  through  $R$ . From the data sheet for the NE555, the voltage on the capacitor increases exponentially with a time constant  $T = RC$ . Assuming a perfect capacitor (no leakage), it will reach the two-thirds  $V_{CC}$  voltage in 1.1 time constants, or  $T$  (time to reach  $2/3 V_{CC}$ ) =  $1.1 \times RC$ .

As soon as the voltage on the capacitor reaches  $2/3 V_{CC}$ , the THRESHOLD line detects this state, and the capacitor is discharged through the DISCHARGE line. Since there is no resistor in line, the capacitor discharges almost instantaneously.

It should be noted that the capacitor charges exponentially, and hence we get a non-linear waveform; not quite what we wanted for our sweep generator. However, if the charging current is kept constant, the voltage will increase linearly—exactly what we need for our ramp—but this requires a bit more complicated circuitry, whereas the simple circuit illustrates the basic principle of charging and discharging to establish a time base.

OK, now we've talked about all of the basic building blocks that we need to put together (at least in theory) our bandscope. Next time, we'll put it all together and show you a real project that pulled together all of this theoretical stuff.

But for now, the low bands are getting into much better shape, so it's time to dust off those NOGAnauts, grab an 80M receiver and get QRV!

—72 de Mike, KO4WX

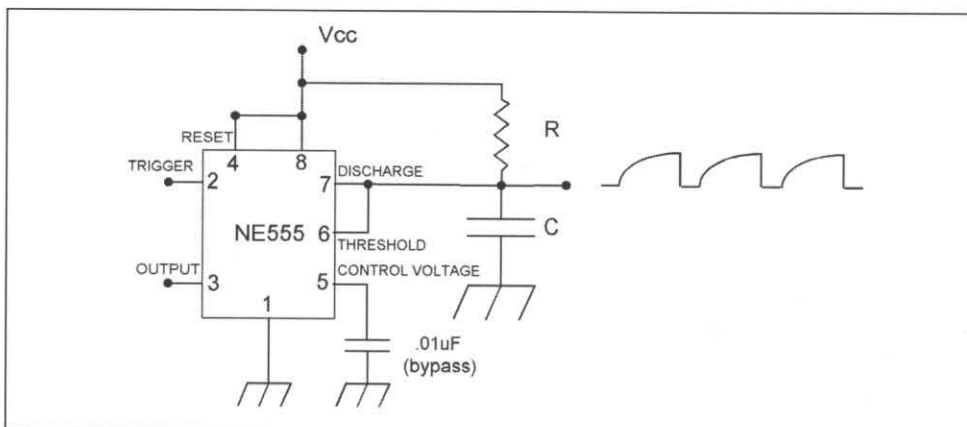

**Figure 4—Basic operation of a charge/discharge circuit using an NE555.**

There's lots in store for this edition of TTAM! The hottest item is the collaborative effort with George Heron, N2APB, and myself. We share a common enthusiasm for homebrewing and want to expand homebrewer's horizons a bit by helping to introduce microcontrollers to QRPdom. To that end George has designed a microcontroller experimenter's platform called the QuickieLab as a common tool to use for developing a series of projects that will combine digital and software power with circuit homebrewing. See George's excellent article in this issue of QRP Quarterly to see what the "QL" is all about. I'm really fired up about this project and can see a whole bunch of future projects based on the QuickieLab.

Designed For Test this time around presents a unique project based roughly on the QuickieLab. The Audio Visual Voltmeter. The AVV for short adds several types of audio "readout" to a digital voltmeter to vastly expand its usefulness. The AVV is also a building block function that can be used for any number of test equipment applications in the ham shack. Coming to Terms discusses telemetry, the process of remote measurement. And tying together the other column topics, Stimulus and Response uses the AVV to achieve telemetry.

### Designed for Test

These days digital multimeters are common in most ham shacks. Very good ones can be bought for under \$50.00 and quite usable products can be found at flea-markets and by mail order for less than \$10.00. The most common type of display is a Liquid Crystal Display—an LCD. The LCD is also ubiquitous on other test equipment such as frequency counters. However recent frequency counter dials such as the N6KR KC1 Counter/Keyer, the SWL FreqMite, the NC-20 AFA and the Arizona ScQRPion Stinger Singer frequency counter "expanded" sensory bandwidth by adding an audible Morse readout. Audible DMMs featuring a voice output are also available in limited markets. However in thinking about useful QuickieLab projects it became apparent that making a digital

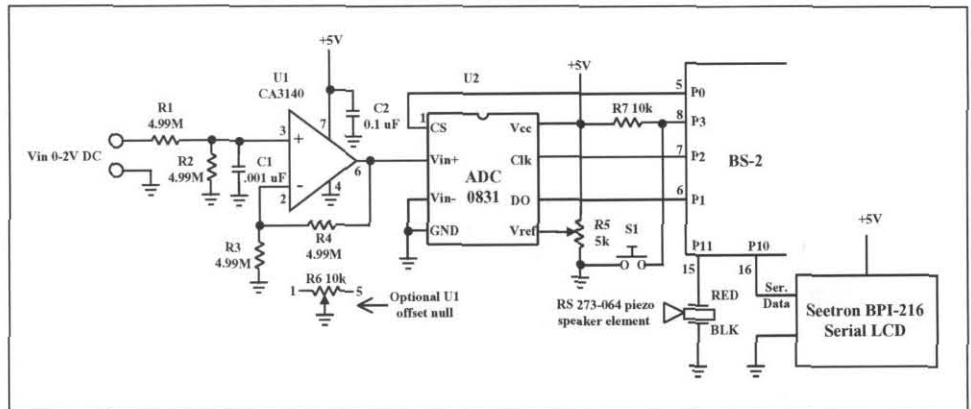

Figure 1—Audio/Visual Voltmeter schematic diagram.

voltmeter with both an LCD display and a Morse numeric readout was extremely easy! Plus the audible output can be expanded to add a variable tone "bar-graph" display function to add the utility afforded by analog voltmeters.

As folks who have used audible "display" frequency counters have found, their usefulness is hardly limited to the visually impaired. There are lots of times when it is more convenient to hear a readout than to look at it. Furthermore a digital display meter used to peak or null a voltage is awkward to quickly interpret. It is much more natural to hear a pitch that varies with the voltmeter reading much as one would watch the needle on an analog meter face.

The Audio/Visual Voltmeter combines all three types of outputs. It has a three-digit LCD display as with ordinary digital voltmeters plus it has selectable audible Morse numeric readout and a tone output whose pitch is low at low voltage input and increases linearly as the voltage rises. The basic measurement range is 0 to 2 volts and the measurement resolution is about 0.5%. The "about" comes about by the fact it uses an 8-bit analog to digital converter, giving a resolution of one part in 255. When scaled by software, the meter reading is 0.00 to 2.00 volts in 0.01 volt steps - good enough for most ham shack uses.

Figure 1 shows the AAV schematic diagram. As presented it isn't built with the QuickieLab so it doesn't use all of the integrated QL functions. However in most respects it is functionally equivalent to the

QL by using the Parallax Board of Education as described in Quickie No.43 in Mike C's IX column. Furthermore if you look over the Quickie you will see that the AAV is a direct descendent of the Morse Voltmeter described there. The Morse Voltmeter was a concept illustration project while the AAV is a practical project featuring high input impedance, multiple "readout" choices and operating mode selection. The AAV can be used by itself or as a building block for other measurement applications.

Op-amp U1 is the high-impedance input buffer. Resistors R1 and R2 set the DC input impedance to 10 megohms and, in conjunction with C1 provide input protection and a small amount of filtering. The low-pass action removes noise and unwanted ac components on the input DC signal. The op-amp provides a buffered feed to the input of analog-to-digital converter (ADC) U2. The input amp's overall gain is set to unity so that with 2 volts on the AVV input terminals exactly 2 volts is applied to the ADC input.

R6 is shown for optional "offset null" adjustment. This corrects for a slight error that exists in any operational amplifier. The offset is an apparent input signal of several mV. It will cause minimal error with an AVV input range of 0-2V but may become an unwanted error source if the AVV range is changed to full-scale values in the 100s of mV. Nulling will be required for AVV projects to be described in the future.

The ADC input reference voltage on pin 5 is set to exactly 2 V by potentiometer R5. This sets the “full-scale” voltage for signal conversion so that is the top end of the voltage range that the AVV will display. Two volts is chosen as a convenient value to use the AVV as a functional building block. The full-scale range can be set to a wide range of values by adjusting U1’s resistors and by minor changes to some constants in the BS2 operating program. Those changes will not be described here due to lack of space. However complete information can be found on the NJQRP web page at [www.njqrp.org/quickielab](http://www.njqrp.org/quickielab). Be sure to bookmark that site and check it frequently. It will be the main reference site for QuickieLab information, projects, application notes and tutorial information about BASIC Stamp programming.

ADC U2 converts its analog input voltage to an 8-bit digital value. Briefly, 0 volts corresponds to a binary value of 0000 0000 which increases in 256 steps to 1111 1111 for a “full-scale” analog input of 2 volts. This digital information is sent serially to the BASIC Stamp chip through the DO (Data Out) lead when the BS2 sets the CS (Chip Select) line high and provides a clock signal on the Clk pin.

The BASIC Stamp then scales the digital inputs to decimal values of 0 to 200 for output. The BS2 has a program stored in it that “reads” ADC inputs as long as power is applied and outputs them (again serially) to a multidigit Liquid Crystal Display. It also monitors pushbutton switch S1 to determine the desired audible output mode. The output mode cycles through Variable Pitch, Morse and No Audio as the pushbutton is pressed successively.

Space limitations and the fear of inducing terminal boredom in readers of this column mean that a complete program listing cannot be provided herein. However it is available on the previously mentioned NJQRP web site and a printed copy will be sent upon request to those who send a business-sized SASE to N2CX at the address provided at the end of this article.

For the algorithmically inclined a flow chart of the Morse routine appears in the IX in Quickie No. 43. A high-level AVV program flow chart for the AVV appears in Figure 2.

It begins when power is applied to the unit. After some initialization (not shown)

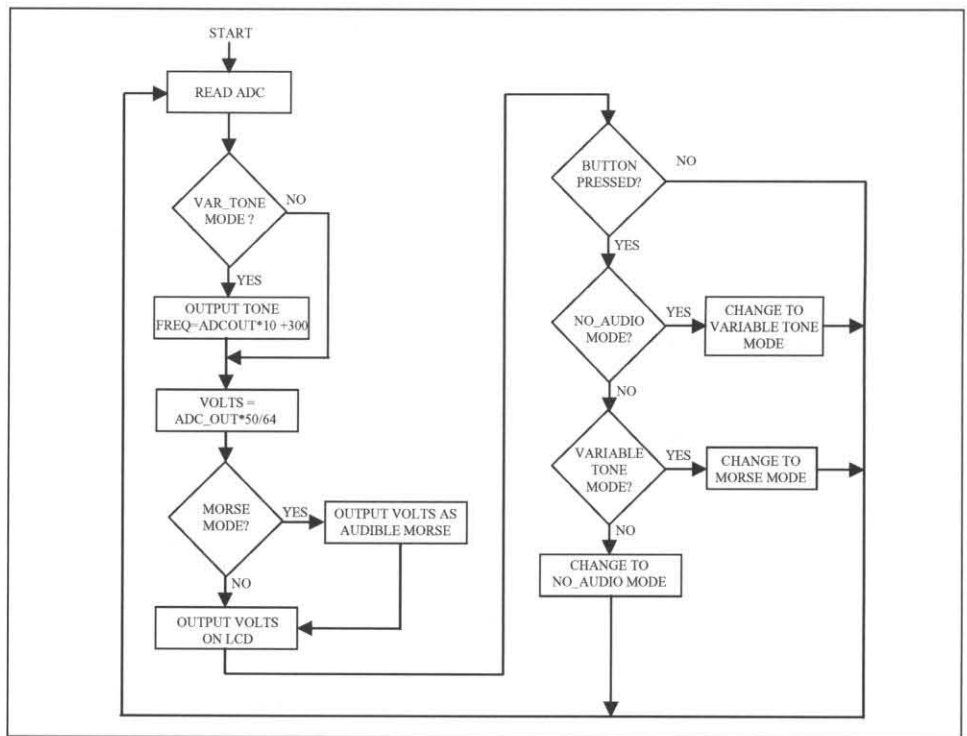

Figure 2—AVV program block diagram.

it first gets a reading from the ADC. Then a check is made to see if the VARIABLE TONE mode has been selected. If so, the 8-bit ADC reading, stored as ADCOUT, is converted to a frequency and the tone is outputted. Tone frequency is scaled so that 0 volts is heard as a 300 Hz tone and frequency goes up linearly to 2850 Hz with a full-scale DC input. Thus the tone varies in almost continuously with applied voltage and stays within the usual audio range of 300 to 3000 Hz.

If the AVV is not in the VARIABLE TONE mode, this step is bypassed and ADCOUT is scaled to within the range of 0-200 and stored as variable VOLTS. Scaling is done by multiplying by 200/255 (reduced to 50/64.) Next a check is made to see if the unit is in MORSE mode. If so, VOLTS is sent as audible numeric Morse characters as was done in the Morse Voltmeter described in Quickie 43. This routine is bypassed if it is not in the MORSE mode.

The VOLTS reading is then displayed on the LCD. Note that LCD readout is done no matter which operating mode is chosen.

Now the Mode Select pushbutton is checked to see if a mode change is to be made. If the button has not been pressed, the program loops back to read the ADC

once again at the beginning.

If the button has been pressed, the operating mode is determined. If the current mode is NO AUDIO then a change is made to the VARIABLE TONE mode when the pushbutton is released and operation returns to reading the ADC. If not in the NO AUDIO mode, a check is made for the VARIABLE TONE mode.

If the VARIABLE TONE mode was previously chosen, the mode is changed to MORSE when the button is released. Then operation returns to the top of the program.

If the operating mode was not VARIABLE TONE that means that it was either MORSE or NO AUDIO and NO AUDIO mode is set and the program once again repeats. Setting NO AUDIO by default is a failsafe operation in case the program goes awry so that it will not be hung up in an annoying audio mode.

As mentioned above the program defaults to the NO AUDIO mode. Successive depressions cycle through the VARIABLE TONE and MORSE modes before returning to NO AUDIO.

The AAV will be adapted to a number of uses in future columns. The list (in my head) is growing rapidly. Basically anything that needs a voltage to be read and displayed is fair game. A short list of candidates is:

1. A multirange digital DC voltmeter
2. An ammeter when a proper shunt is added
3. Analog meter reading (audibly) by reading voltage across an analog meter.
4. An audio voltmeter when a precision diode is added
5. A dB-reading audio meter if a logarithmic detector is added
6. An RF voltmeter or wattmeter if an appropriate detector is added
7. A dB-reading RF voltmeter or RF power meter if an RF logarithmic power detector is added
8. An SWR meter (can be done quite cleverly using ratiometric ADC features)
9. AVV audio "displays" can be sent via wireless means for remote metering
10. A precision version of all of the above if the ADC is replaced with a higher resolution version

### Coming to Terms

A natural offshoot of testing and measurement is telemetry. The word means, literally, metering at a distance. One can think of any number of reasons for wanting to perform measurements in one location and "telemeter" (send) the readings elsewhere. Real-world telemetry often involves monitoring a physically large or widely separated system from a central location. Pipelines, commercial power grids and factories are several examples. On the other hand, for nuclear power plants or orbiting spacecraft, remote telemetry is a matter of personal safety. And sometimes, as in the antenna testing described below, one has to make measurements at a distance as a matter of practicality. Picture measuring an antenna by setting up the antenna, walking a quarter

mile away to measure the field strength, going back to the antenna to make a small change, then going back to the field strength, etc. That gets old pretty quickly. It's much easier to telemeter the field strength reading back to where you are working on the antenna.

Most of the test equipment we use as homebrewers is not directly suited to remote reading. Its only output is a front panel meter. In industry, though, a trend toward automated testing has resulted in test equipment that has either an analog or digital output that can be used to feed a computer, a printer or some communications equipment for sending readings remotely. Most often the data is in digital form, through either a serial or parallel bus. This makes it relatively simple to telemeter with standard digital communications.

An older though still widely used telemetry technique uses equipment that provides analog outputs as either a voltage or current. For short distances this can be fed to a remote monitoring point via wire or cable. More distant communications is often done via telephone lines or radio links. In those cases, the analog signal is converted to either an audio tone or other variable frequency signal that is then used to modulate a transmitted signal. When demodulated at the other end of the link, the signal is converted back to analog form for metering. This is precisely what will be described in the next section of this column.

### Stimulus and Response

At a recent NJQRP meeting my good friend Tony, W2GUM asked a question that gives a good opportunity to discuss some neat test principles! He is interested in antenna testing and notes that accurate

pattern and radiated field strength measurements need to be performed some distance from the antenna. In fact, the rule of thumb is that the field strength meter (FSM) needs to be at least 4 to 10 wavelengths from the test antenna to measure the true "far-field" radiation. To put this in perspective, let's see how far apart the test antenna and FSM have to be. For 20 meter antennas this means that you have to go out about 260 feet for 4 wavelengths or 656 feet for 10 waves out. And for 40, you're talking about 520 feet to about 1/4 mile!

Tony pointed out that it is awkward to tweak an antenna, go out to the FSM for a reading then go back and re-diddle the antenna, etc. For A/B antenna comparisons it would be even more labor intensive. He pointed out that it would be much easier to be able to read the FSM at the test antenna end and asked how difficult that would be.

A couple of methods come to mind immediately. The basic principle for them is shown in Figure 3. The antenna-under-test on the right side of the figure sends a test signal from the transmitter shown. A Field Strength Meter and associated receive antenna are located the appropriate distance away to monitor this signal. Now since we are radio amateurs it is only logical that we use radio transmission to send the FSM readings back to the test antenna location. If you have an antenna test partner, this could be a VHF hand-held transceiver under his control at the far end and a complementary one at the near end. With a prearranged protocol the same transceivers can also be used for voice transmissions to coordinate the effort. For moderate distances even some of the inexpensive UHF Family Service Radios can be pressed into service.

The way to telemeter is to send an

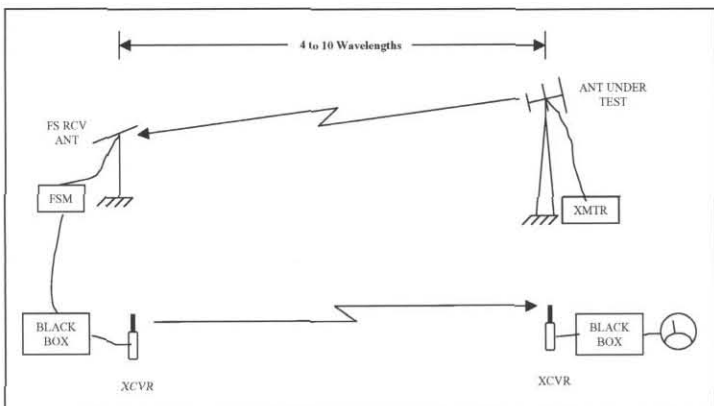

Figure 3—Remote field strength monitoring.

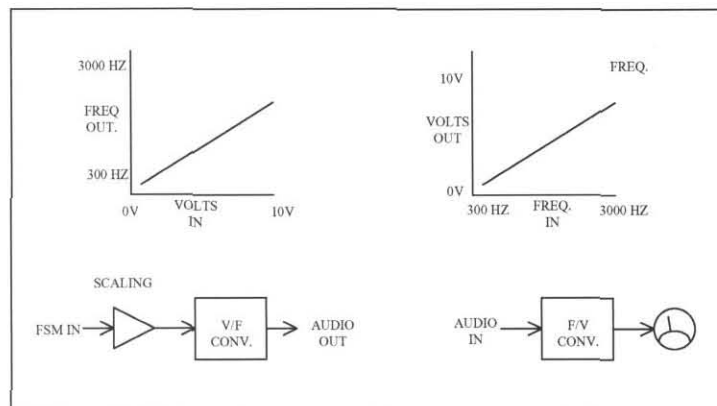

Figure 4—Telemetry by voltage to frequency conversion.

audio signal over the radio link. This audio signal has to be within the ordinary voice range of about 300 to 3000 Hz (maybe 300 to 2500 Hz to be conservative) and it has to convey the FSM reading. At the receive end it has to be converted back into a numeric reading that corresponds to the original reading. This process is illustrated in Figure 4.

While a radio link is shown, this is to say that other forms of communication couldn't be used. Anything that will transmit audio from the FSM across the test range is OK. You could use a twisted pair audio cable (perhaps buried to prevent inadvertently corrupting the apparent antenna radiation.) Alternatively an ordinary wireline or cellular telephone would do the trick. Then too wireless transmission does not always need RF. A modulated light link using laser pointer or a collimated infrared LED/photodetector could serve the purpose over a line of sight path.

A simple way to do this is to use a Voltage-to-Frequency Converter (VFC). This device produces a pitch that varies with applied DC voltage. So the DC output from the FSM is converted to a tone that changes frequency as the received field strength varies. It just happens that the VFC function is so common in industrial

electronics that several manufacturers make integrated circuit chips that do exactly that. Examples are the National Semiconductor LM331 and the EXAR XR4151. These chips can be purchased for about \$5 each from mail order distributors Digi-key and Jameco while Mouser carries the NTE890, a '4151 substitute.

At the receive end of the link the tone is converted back from a varying frequency to a voltage that can be read on a meter. Naturally enough this function is called Frequency-to-Voltage Conversion (FVC). And the same VFC chips can be wired as FVCs as well.

An alternative method uses the Audio/Visual Voltmeter (AVV) described in Designed For Test. If set up for variable pitch output, it performs the VFC function and an FVC can be used at the receive end. Alternatively, the Morse code numerical output can be employed for a direct audible readout via the radio link. Slight modification to the AVV programming can give both outputs alternately.

Naturally the FSM output has to be scaled to make the VFC produce a tone in the desired range. And the FVC too has to be scaled to produce an appropriate meter reading. Both can be accomplished by use of operational amplifiers with adjustable

gain and input offset. Once this is done, calibration of exact dB variation over the link can be done as well by inserting known attenuators on the test transmitter and making a calibration chart of meter readings vs. attenuation. All the rest is simply details.

Yet a third method is to let someone else build a telemetry system for you. If money is no object, a number of companies can supply commercial or military grade telemetering products. Within the amateur radio community, the Tucson Amateur Packet Radio group used to offer a board-level amateur telemetry system the METCON-1. Their web page [www.tapr.org](http://www.tapr.org) shows this as a discontinued kit but states that they are working on a newer version the METCON-2.

That's it for this time around. I hope you are as enthused as I am about the QuickieLab concept and will check out the NJQRP web page for more details. I apologize if some of the figures and descriptions in this column are sketchy, but the web page offers room for expanded documentation. And while I have listed some projects for the future, please feel free to suggest more or ask for more info on what this column has presented.

••

## QRP ARCI — The Toy Store

T-shirts with the QRP-ARCI Logo!

Shirts are \$15 postpaid • Second & third shirt are \$10 each

Please check for size & color availability before ordering

QRP ARCI Patches \$5 postpaid

QRP ARCI Coffee Mugs \$9 postpaid

QRP ARCI logo pins \$8 postpaid

QRP ARCI logo Hats

Denim Blue • Charcoal • Tan/blue • Tan/green • Green • Tan

Hats are \$15 each postpaid • Second & third hats are \$10

By mail; checks made out to QRP-ARCI:

QRP ARCI — The Toy Store

2130 Harrington Road

Attica, MI 48412-9312

Or PayPal to [k8dd@arrl.net](mailto:k8dd@arrl.net)

<http://www.qsl.net/k8dd/toystore/thetoystore.htm>

## Winter Projects

Dayton is past, Field Day is over, and the weather is turning cooler. When the cold and rain drives activities indoors, clubs turn from monthly meetings, to operating activities and individual pursuits.

But there's no reason for club meetings and activities to cool off as well. Consider a mid-winter construction project for a single or multiple meeting activity.

There are several kits available this year, from both clubs and commercial sources. Poll the members to see what would be a useful project that at least half the members would be interested in building together. A SWR/Power meter? Electronic Keyer? Portable tuner? A simple transceiver?

The key to selection often centers on cost. What does the finished project cost once the enclosure, connectors, and finishing is all factored in?

Some of the most successful QRP projects offered by the Northern Californian QRP Club, New Jersey QRP Club, and the Northern Georgia QRP Club have been in the \$20 - \$30 price range and designed for simple enclosures, and at least two clubs, The Kentucky QRP Club and the Cascade QRP Club, are using Dave Benson's Rock-Mite crystal-controlled 40 meter transceiver for a winter 'burn solder' club project (the Rock-Mite has the benefit of an onboard keyer, making its \$25 shipped price a real value).

The KY-QRP Club will then see which club member can achieve the greatest Miles Per Watt contact with the rig.

The NoGa QRP Club continues to offer the NoGaWatt SWR/Watt Meter kit that fits nicely in one or two Altoid cases. Based on the Stockton design, it is \$22 (including shipping), with the only other cost being a couple of switches and RF connectors.

The NorCal QRP Club still offers the BLT (Balanced Line Tuner) for \$24, shipped. It's good for 40-10 meters and it comes with printed circuit boards to solder into a case.

Keeping within the \$20-\$30 range and short construction period, it seems everyone needs another keyer or two. The PK-3

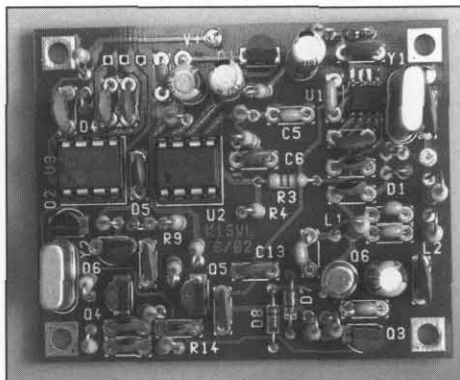

**This transceiver kit from K1SWL's Small Wonder Labs is a fun club construction project.**

from Jackson Harbor Press is hard to beat with its potentiometer speed control, morse speed readout, and several memories. Morse Express offers the kit, and a hardware kit with all the needed switches and connectors, for \$27.45 plus shipping.

To function well as a club project, access to a school electronic lab, complete with soldering stations, is a definite plus. Otherwise you need enough table space for everyone to plug in a soldering iron and an area for testing or debugging the occasional unit that refuses to kick start without a little help. Here's also a good opportunity for members to see if an oscilloscope is really worth purchasing, or if a soldering station is really that much better than a simple soldering iron.

Consider inviting some members of the local QRO club to participate in the fun. QRO ops may not have built anything in years, and a simple project may be just the venue for them to develop a renewed interest in building.

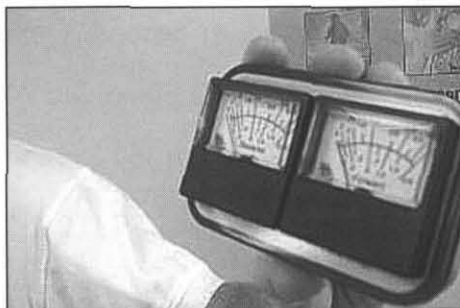

**Tom, K4JDN, shows off his completed NoGaWatt power and SWR meter.**

A simple transceiver that can be used by club members on thirty or forty meters can add the option of a club net. Forty Meters usually has enough ground wave for an area net (as long as you pick a night when the hounds aren't chasing the foxes!).

There may also be a few sparkplugs in the club that want to kit up a club project to offer to others. That's another story altogether, but it's certainly a way to pull together members to stuff kits, prepare instructions, and beta-test a design before release.

Here are links to information on the referenced kits:

*Morse Express:* <http://www.MorseX.com/jhp/index.htm#ik2>

*Norcal QRP Club:* <http://www.fix.net/~jparker/norcal.html>

*Small Wonder Labs:* <http://smallwonder-labs.com/>

*NJ-QRP Club:* <http://www.njqrp.org/>

This has been a sobering past year for many of us, with a ground swell of interest developing in the area of emergency preparation. Field Day is an effective annual emergency communications test, but how many of your club members know the details of interfacing their communications capabilities with the needs of local emergency services agencies?

That's where the ARRL can be of assistance. The League has available a three-part series aimed at training communications specialists for disaster operations:

*Level I—Introduction to Amateur Radio Emergency Communications Course (EC-001)*

*Level II—Intermediate Amateur Radio Emergency Communications Course (EC-002)*

*Level III—Advanced Amateur Radio Emergency Communications Course (EC-003).*

These classes are available online, as well as in booklets. They are designed to be taught by a certification instructor who has already passed the particular course he is



instructing, or through an online course working with a mentor. Each of the level booklets are \$10, and the online courses and certification are available at additional cost. A \$181,900 Federal Homeland Security grant to the ARRL will allow up to 1,700 amateur radio operators to complete the Level 1 course, and a club project could be to complete these three courses over the

course of the winter. More information is available at <http://www.arrl.org/cce/>

A recent email I received commented that the active clubs were the ones getting the publicity in *QRP Quarterly*. If your club has activities of interest to others then publicize them! If you aren't sending me an email of present and future events, and projects that I can share with readers, why

not? Let me know about your club's Fall and Winter projects, planned public service events, and anytime you are working with youth in your area, and I'll contact your club's representative for more information and what supporting illustrations or pictures are available.

—de Mike, KL7IXI ●●

## QRP Activities at Hamboree 2002

**H**amboree 2002 took place in South Sioux City, NE on June 14-15 in the Siouxland Convention Center. The event was sponsored by the "3900 Club" (see their web site at [www.3900club.com](http://www.3900club.com)). In addition to the usual Flea Market, DXCC card checking, ARRL Forums and a Banquet (featuring ARRL President Jim Haynie, W5JBP as speaker), there were activities sponsored by the Iowa QRP Club, the Bicycle Mobile Hams of America and QCWA.

QRP activities got under way Friday evening with an informal get-together at a local Pizza restaurant followed by a "group build" of PIXIE transceiver kits provided at a nominal cost by the Iowa QRP Club. On Saturday, there were many presentations of interest to QRPers including talks by well-known QRPers Jim "Dr. Megacycle" Duffy, KK6MC, and Brian Kassel, K7RE. Adrian Weiss, WØRSP, was scheduled to give a presentation but was unable to attend due to care problems.

One of the highlights on Saturday was a short "Show and Tell" by Warren Amfahr, WØWL, of a one-tube 5M



Anthony Norem, NØRJK, showing off his "bicycle mobile." The bike is equipped with an FT-817 transceiver, Z-11 Autotuner, battery pack and assorted antennas.



Everyone hard at work during the Friday evening "PIXIE" QRP Transceiver building session.



Brian Kassel, K7RE, telling us about "Portable Contest Operation."

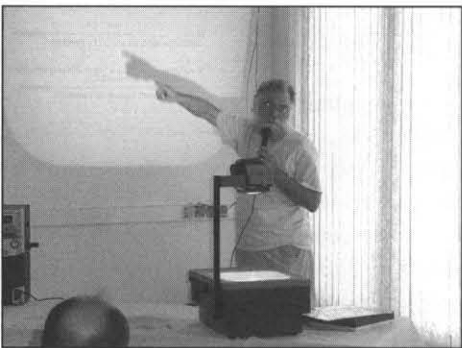

Jim "Dr. Megacycle" Duffey, KK6MC/5, giving us the straight scoop in his talk "Efficiency of Small Antennas."

transceiver that he built in 1937 from an article in *Popular Mechanics* and operated "bicycle mobile." Although not an avid QRP'er (he likes to build high power amplifiers and has little patience for "weak signals"), Warren likes to attend QRP sponsored functions for their technical content. (Warren was an RF design engineer at Collins Radio for many years.) ●●

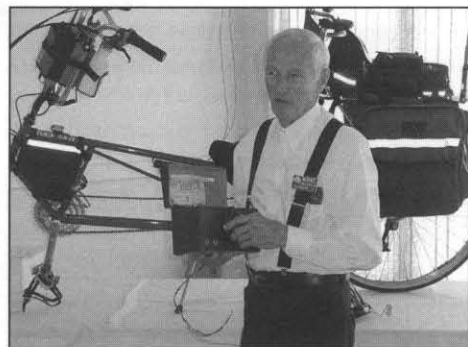

Warren Amfahr, WØWL, showing off a 5M "bicycle mobile" transceiver that he built as a youngster in 1937.



A close up of Warren's 1937 vintage single tube 5M transceiver. The rig is a super regenerative receiver in RX mode and an AM modulated self-excited oscillator in TX mode. Stability? We didn't ask...but he says that he made many contacts with it!

## Kentucky QRP Group

James A. McDonnell—KE4QCJ

ke4qcj@aol.com

In 1998, Bob Cooper, AF4OI, and Tom Erwin, WD9GON, were interested in getting together a group of amateurs interested in QRP. Thus started the Kentucky QRP Group, a sub-group of the Bluegrass Amateur Radio Society. Today our membership is over 20 members. We enjoy home brewing, experimenting, demonstrating and instructing, and have experimented and modified Pixie II radios. Everything we've done has been 5 watts or less including APRS demonstrations. This year was the first year we even ran an experimental solar/battery powered QRP station for Field Day, and numerous contacts were made, several of them DX.

Our demonstrations are for any interested amateurs locally, as well as any who belong to neighboring radio clubs. As far as instruction goes, we have set up stations for Scout World, Jamboree On The Air, and Boy Scout merit badge fairs. It's amazing how many young people are interested in radios, communication, and even CW.



Field Day 2002 setup.

While we dig into some heavy projects, we still have fun and help each other. What are hams for anyhow? Hi Hi.

We have a local meeting area at the local Red Cross building, and membership is free to anyone interested. We hold our meetings on the first Tuesday of every month, and hold a weekly net for anyone interested in QRP. Anyone wishing to know more about our group should feel



KE4QCJ demonstrates phone and APRS.

free to contact Bob Cooper at: af4oi@cs.com, or have a look at the KY QRP web page located at: <<http://our-world.cs.com/AF4OI/ky-qrp.htm>>.

Our current projects include a contest involving the Pixie II (construction, operation and most contacts), and a miles-per-watt contest. We are also preparing a demonstration for our upcoming Hamfest on August 4, 2002. ●●



The Kentucky QRP Group.



Rufus (not yet licensed), the club mascot.



The busy hall at Scout World 2002.

## The Micro-80 Transceiver

Oleg V. Borodin—RV3GM

rv3gm@qsl.net

I have received many questions about the Micro-80, and I will try to answer most of them here. The Micro-80 transceiver was first published in "SPRAT," the G-QRP Club journal, more than 10 years ago and reprinted in many worldwide Amateur Radio magazines and bulletins (see Fig. 1). It was the prototype for the well-known PIXIE 2 and Tiny-Tornado micro-transceiver kits. The "heart" of the Micro-80 is a single HF transistor (Q2) used as

the transmitter PA and receiver mixer. A single transistor crystal oscillator and a simple two-transistor audio amplifier scheme allows a very small size functional CW transceiver. Printed circuit boards as small as 35 x 50 mm have been used, and as you can see from Fig. 1, the Micro-80 scheme is the same as the PIXIE but for the two transistors audio-amp in place of an LM386 IC. Yes, I agree with PIXIE builders that the LM386 has more gain. At

the time I designed the Micro-80, there was a problem obtaining any small audio-amp chips here in Russia. My major aim was to make the smallest transceiver and I have met it, I hope. [2N2222s or 2N4401s can be used for Q1-Q4 inclusive. A 2N5109 or 2N3866 for Q2 might give more output, if you don't mind the larger physical size. Note that high impedance headphones must be used to achieve adequate audio gain. —WIHUE]

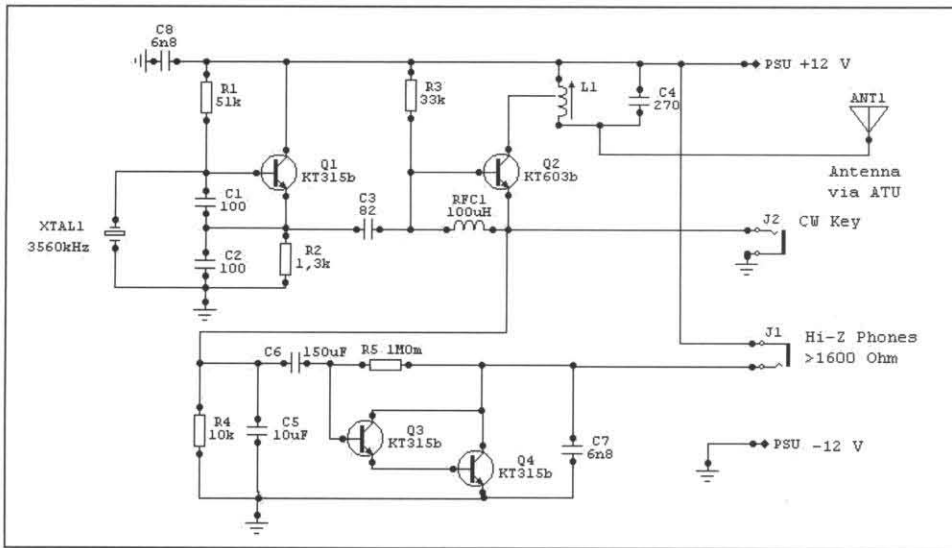

Figure 1—The Micro-80 schematic diagram.

First of all, I want to say that the Micro-80 was designed for the 80 meter band. Many experiments shows that the best results are on 80 meters, although some versions may work good enough on 40 or 30 meter. Output power and RX sensitivity at 20 meters are very low. My tests with a 20 meter version gives about 25  $\mu$ V RX sensitivity and 70 - 80 mW TX output. The same tests with an 80 meter transceiver gave more than 300 mW out and better than 5  $\mu$ V RX sensitivity. The CW signal quality is a good and clear in any case.

About the TX output filter: Often I get questions about the use of an ordinary parallel LC filter. Why not use a low-pass filter? There is no theory utilized here, just practical experience. I tried all the types of filters, but had the best results with a parallel LC filter tapped at the 1/4 point. This gave the highest output without deterioration in RX parameters. Try it yourself, please!

I've had some questions about a tunable frequency version. Sorry, but the simplest scheme of oscillator may not use a tunable LC circuit because the stability would be so poor that it would drift all over the band! Secondly, you'll have a large frequency "shift" between RX and TX—about 20-30 kHz! However, it is possible to use a crystal with a variable capacitor or inductance in series (Figure 2). A capacitor in series with the xtal may give you a shift of 2-3 kHz above the fundamental frequency and an inductance 1.5-2 kHz down. I've read that a variable C in series with a fixed L will give a shift above and below the fundamental, but my experiments did

not get me good results. I have used a variable capacitor of 5 to 50 pF and obtained a shift of about 10 kHz with a 14070 kHz xtal. This method provides the possibility of using a 20M version of the Micro-80 to receive PSK31 stations at 14070 kHz. You can try it, and I'm sure you'll have great fun! Just a reminder—power your simple DC receiver from a battery for best results.

This brings up the next question, about the power supply. The Micro-80, like other DC transceivers, has a high audio gain. It is very sensitivity to the smallest power supply hum. I doubt that you can build a high quality power supply with current pulses less than 5  $\mu$ V! In any case, you'll hear current hum in your headphones since they connect to the power "plus" directly. I recommend a 1 amp-hour 9-12V battery as a power source. I have had good results using NiMn cells from portable cash-registered equipment, and I can operate over a day with such a battery. For portable operation, I also use a solar panel with the cells (Figure 3).

Many Amateurs like to use a PC for operating. It's easy to connect the Micro-80 to a PC (see Figure 4). Exchange headphones for a resistive dummy load and connect to the sound card via a capacitor. Also connect any available COM port though a simple one transistor keyer to the "CW Key" connector of the Micro-80. There are many software

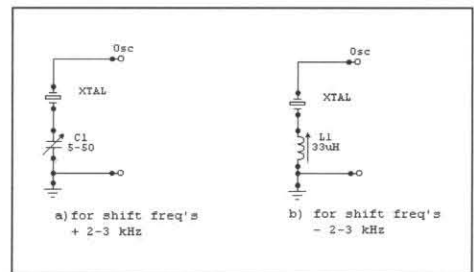

Figure 2—Vxo with variable C and L.

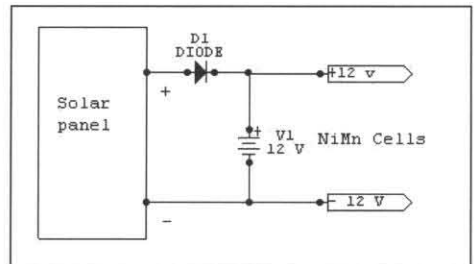

Figure 3—Solar panel and NiMn cells for Micro-80 power supply.

programs to receive and transmit Morse code, and I use UA9OSV's programs CW-Get and CW-Type. These are freeware programs, and they can be found at [www.qrz.ru](http://www.qrz.ru) in the "software" catalogue. By the way, the Micro-80 for the 20 meter band (at 14070 kHz) works well as a PSK31 receiver using DigiPan software. Sorry, but it is impossible to use the Micro-80 to transmit PSK31!

Try this simple radio and you'll have much fun time with it, I'm sure. I will send a Micro-80 kit of parts with PCB and manual to any Amateur who wants to try it; just order it from me by e-mail or post. I don't ask for payment for the kits, only the mail-cost, but extra payment would be appreciated if you find it possible.

Hope to meet you soon on the QRP frequencies!

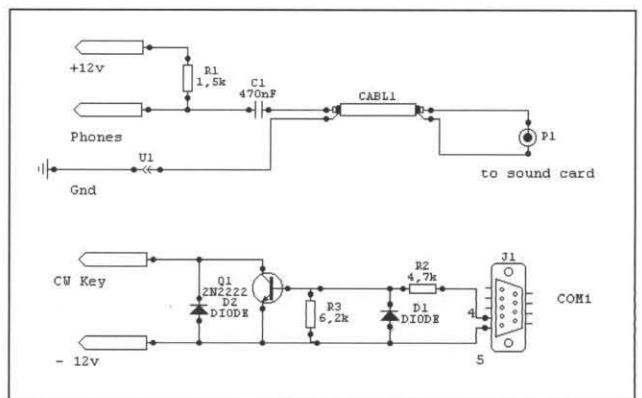

Figure 4—Micro-80 to PC connections.

# QRP Contests

Randy Foltz—K7TQ

rfoltz@turbonet.com

In this version of the QRP Contests you will find the results from the Milliwatt Field Day and the Summer Homebrew Contests as well as a couple of coming contest announcements. I've included "How to do the contest" side bars for those just curious about wetting their feet in QRP contests. It should also be a good reminder for the rest of us, as well.

A contest submission to QRP ARCI consists of a summary sheet and a copy of your logs. The High Claimed Scores reporting form is a satisfactory substitute for a summary sheet. So are the summary sheets printed by most contest logging programs. You still need to send me a copy of your logs. Without them you won't be eligible for any certificates. I also use contest submissions as a gauge of contest popularity. Unpopular contests don't survive. One of the 2002 contests is on the bubble.

After each contest you can use the High Claimed Scores form at <http://personal.palouse.net/rfoltz/arci/form.htm> to send me your contest summary. Your log can be sent separately by either e-mail or regular mail. Watch the claimed scores change each evening at 9 PM Pacific Time for 10 days after the contest by looking at [http://personal.palouse.net/rfoltz/arci/high\\_clm.htm](http://personal.palouse.net/rfoltz/arci/high_clm.htm) This web page contains only those results submitted by using the web form above.

Enough of my stuff, on to what you have done. See you on the air!

## Milliwatt Field Day

More stations reported their results to QRP ARCI than any in the last five years. I know that we QRPers have always been out for Field Day, but it is nice to see the increase in reporting. In this event we recognize the top scorers in Club Class, 5 watt-2 operator, 5 watt-1 operator, 1 watt-2 operator, and 1 watt-1 operator. Certificates to those leaders have been sent out.

There were several interesting stories associated with Field Day. W2AGN operated W2DWC from a boat. WD9EWK went from hot Phoenix to cooler Flagstaff. N7RI worked 21 sections using a low inverted vee on 40 m using a mere 1 W on SSB. K3HX consumed batteries like it was going out of style. Many stations used a

solar panel for charging their batteries. Read the soapbox to see what the participants had to say.

A noteworthy report was turned in by

### 2002 Milliwatt Field Day Category Winners:

Category	Winner	Score*
Club Class	AE6C	4635
5 W - 2 operator	K8RL	4530
5 W - 1 operator	NØUR	6700
1 W - 1 operator	W3TS	4710

\*without bonus points

NØUR. His score of 6700 in the 1B-battery class came from 663 CW and 7 digital QSOs. Another tip of the hat to Jim's contesting skills.

Don't forget: 1) next year's event is the third full weekend of June, 2) it isn't really a milliwatt event, and 3) to send in your report.

## Soapbox

N3EPA—We always have fun running Field Day with QRP. AGØT—Rig was a Yaesu FT-817, deep-cycle lead-acid 12V battery. Had planned to try phone if things got too slow on CW, but CW activity was such that I never did switch to SSB. Great fun! WD9EWK—I went to Flagstaff, AZ and operated from the Fort Tuthill Park. I operated only on Saturday since the operating location closed at sunset. I had equipment problems with the digital modes, so only made SSB QSOs this year. N7RI—Even with a low inverted vee sandwiched between two buildings, I managed to work 21 sections on 40M SSB running a K2 at 1 watt. The strategy was hunt and pounce, calling stations as they first appeared on the band, or after their novelty had worn off. K3HX—My "float" battery sank so I pulled the battery from my TR-8 auto.

## Mark Your Calendars:

*Running of the Bulls*  
November 2-4, 2002

*Holiday Spirits Homebrew Sprint*  
December 1, 2002

*Topband CW & SSB Sprint*  
December 4-5, 2002

When it packed it in, grabbed the starting battery from the whole house generator and re-charged the TR-8 battery with a small, portable generator. When the generator starting battery quit, back to the TR-8 battery which held up until the end of the contest. K2WNY—A low-key affair for us this year. It was fun to run 6M this year. K4JSI—Two Field Days in a row using direct conversion receivers is quite enough! W2DWC—Great conditions. Solar panel worked well. Only limitation was one op gets tired!

## Summer Homebrew Sprint

In the 2002 version of the Summer Homebrew Sprint, N9NE again defended his previous top place finish by scoring 193,000 points. K5ZTY and K7RE had a close race for second place with Bill, K5ZTY, just edging out Brian, K7RE, near the end of the contest. N9NE now has two consecutive Summer Homebrew crowns.

### 2002 Summer Homebrew Sprint Top Three:

N9NE	193,000
K5ZTY	141,567
K7RE	137,150

### Category Winners:

LT 250 mW	WJ4P	42,540
LT 1W	W5KDJ	117,600
15M	WA9PWP	7,688
20M	WØPWE	32,090
40M	K9PX	47,714
All-bands	KH6B	36,762

He had the lead after the first hour with 28 QSOs and 3 band changes. No one even got close after the first 30 minutes. At the end of the 4 hours, Todd had made 92 QSOs on 5 bands. Both 10M and 80M were because N9NE and the other station agreed to QSY to those bands while exchanging the con-

**2002 MILLIWATT FIELD DAY**

Class	Call	Section	Score w/o bonus	CW Qs	Digital Qs	Phone Qs	Nr. Ops	Pwr	Rig	Antennas
<b>CLUB CLASS</b>										
Neurosa's Gopher Munchers										
1A	AE6C	SCV	4635	458	0	11	4	5	K2, K1	250' vee beam, 40 m delta loop
1A	KM4O	GA	1550	155	0	0		5		
WNY QRP Society										
1A	K2WNY	WNY	1345	208	0	61	2	5	K2, IC551D	N2CX gusher
Hilo ARC & HI QRP Club										
1A	KH6IN	PAC	915	75	0	33	3	5	K2, Scout	140' sloping diamond loop
1A-Battery	W2DWC		3600	360	0	0	1	5	K2	100' Zepp
Eastern PA QRP										
2A	N3EPA	EPA	2995	219	0	161	5	5		
Keno Amateur Radio Club										
2A	K7ENO	ORE	570	0	2	112	2	5		
Austin Amateur Radio Club										
5A	W5KA	STX	3940	80	98	610	5	5		
<b>5 WATTS - 2 OPS</b>										
1B-battery	K8RL	WV	4530	453	0	0	2	5	K2	Dipoles
<b>5 WATTS - 1 OP</b>										
1B	AA5CK	OK	2620	262	0	0	1	5		
1B-battery	NØUR	MN	6700	663	7	0	1	5		
1B-battery	K5AAR	OK	3500	350	0	0	1	5	HB xcvr	330' horiz loop
1B-battery	AC4XO	VA	2330	233	0	0	1	5	K2	Zepp, wire beam, 100' end fed wire
1B-battery	K4JSI	MDC	2300	230	0	0	1	5		
1B-battery	W3ZMN	EPA	1540	154	0	0	1	5	K2	96' end fed wire
1B-battery	N7CEE	CO	1310	131	0	0	1	5		
1B-battery	K7TQ	ID	1150	115	0	0	1	5	K2	Dipoles
1B-battery	WD9EWK	AZ	180	0	0	36	1	5	FT817	Dipole
1B-battery	WØEFK/7	WWA	140	0	0	28	1	5		
1B-battery	AE4BZ	SFL	90	0	0	18	1			
1E	W8UE	MI	4950	495	0	0	1	5	TenTec 544	Dipoles
1E	AGØT	ND	3160	316	0	0	1	5	FT817	
1E	K3HX	WPA	1540	308	0	0	1	5		
1E	WB6BWZ	GA	1085	170	47	0	1	5	FT817	153' OCF doublet
	KW4JS	TN	2200	210	0	0	1	5	K2	Trap Vert, G5RV
<b>1 WATT - 1 OP</b>										
1B-battery	W3TS	EPA	4710	471	0	0	1	1	HB Superhet	130' doublet @ 50'
1B-battery	K1HJ	EMA	840	168	0	0	1	1	K1	35' wire vert
1B-battery	N7RI	AZ	290	0	0	58	1	1	K2	Inv vee

test information. It often goes something like this after finishing the contest exchange "... QSY 10?...R QSY 10 28060 U CALL ...R 28060." N9NE picked up 10,000 bonus points, ten QSO points, and two additional multipliers this way. It is a good contesting skill to develop.

The solar flux for the July 14, 2002 contest was 144 with an A index of 6. These values are nearly identical to last

year. The increase in scores is likely an indication of more activity by QRP contesters. Of course, a general rise in the quality of QRP contesters could also be a possibility...no make that a probability.

**Soapbox**

**KB2PLW**—Great contest...CW and homebrew forever! **KH6B**—I operated from Kaloli Point Hawaii, out in the

boonies. **W6ORS/KH6** agreed to band-hop, giving me action on 'all' bands. **K4AHK**—Bands noisy and signals very weak. 20M almost dead here in VA. **NA3V**—Propagation really bad on high bands in first hour, but settled down later. **WA9PWP**—Put in some time trying to drain the NiMH cells in my K1! **WØUFO**—My time was limited but it was fun. Sorry that I had only my NC-20 at my

2002 SUMMER HOMEBREW SPRINT

QTH	Call	Score	Pts	SPC	Bonus	Power	Bands	Time	Rig	Antenna
AK	AL7FS	27222	97	18	15000	LT5	20,15	2	K2	KT-34A @ 40'
AL	K4AGT	7464	44	8	5000	LT5	40	1.7	OHR100	Gap Titan
AZ	NQ7X	21413	133	23	0	LT5	20,15	1.5		
	AA7EQ	12961	47	9	10000	LT5	20,15	4	K2	GAP Titan
BC	VE7SL	14740	98	13	2000	LT1	20	3	Tuna Tin II/20	A3S @ 55'
CA	NK6A	39050	166	25	10000	LT5	20,15	3	K2, K1	C4 @ 40'
CO	KIØII	20920	84	13	10000	LT1	20,15	1	K2	Carolina window
FL	K4MF	89382	253	42	15000	LT5	40,20,15	4	K1	A3, 40 m dipole
	KG4FSN	20960	114	20	5000	LT5		3	NW20	Dipole
HI	KH6B	36762	69	14	30000	LT5	160,80,40,20,15,10	4	K2	48' vert loop
	W6ORS	1260	30	6	0	LT5	160,80,40,20,15,10	4	DX70T	OCF wire
IA	WØPWE	32090	129	21	5000	LT1	20	1.5	Manhattan SST-20	Dipole
ID	K7TQ	107904	316	42	15000	LT5	40,20,15	4	K2	C4S
IN	K9PX	47714	226	27	5000	LT5	40	3.5	K2	80 m loop
KS	WB0SMZ	6260	30	6	5000	LT5	20	0.5	Norcal 20	Butternut vert
MA	K1HJ	15940	54	11	10000	LT1	40,20	1	K1	Dipole, long wire
MD	KB3WK	27100	130	17	5000	LT1	20	4	K2	3 el beam @ 40'
	KØFRP/3	9774	62	11	5000	LT5	20	2	K1	Bazooka dipole @ 6'
ME	KØZK	65246	194	37	15000	LT5	40,20,15	4	K2	Attic dipole
MI	KA1DDB	34642	122	23	15000	LT5		2.3	Sierra	G5RV
	K8CV	18669	127	21	0	LT5	40,20,15	3.5		
MN	WØUFO	25874	142	21	5000	LT5	20	2.5	NC20	Dipole @ 20'
	NØUR	24020	130	22	4000	LT5	20,15	0.6	K2	Yagi
NH	KN1H	10750	25	3	10000	LT1	40,20	1	HB xmtr and rcvr	300' long wire
NJ	W2AGN	62532	217	28	20000	LT5	80,40,20,15	3.5	K2	KT34, 300' loop, dipole
	W2BVH	11554	37	6	10000	LT5	40,20	1	K2	80 m CF Zepp
	W2JEK	7128	38	8	5000	LT5	40	1	OHR500	Dipole @ 25'
NY	KG2H	14389	57	11	10000	LT5	40,20	2	K2	Vert
	KB2PLW	7450	35	10	5000	LT5	40	4	Might Mite, MRX40	Folded twin lead dipole
PA	K3HX	54978	238	33	0	LT5	40,20	3.75	TS-870	Dipoles
	NA3V	38831	179	27	5000	LT5	40,20,15	2.75	IC756, OHR100	130' doublet @ 65'
SC	WJ4P	42540	102	18	15000	LT250	40,20,15	4	K2	OFC dipole
SD	K7RE	137150	349	50	15000	LT5	40,20,15	4	K2	Horiz 80 m loop
TX	K5ZTY	141567	369	49	15000	LT5	40,20,15	4	K2	C4S
	W5KDJ	117600	269	40	10000	LT1	20,15	4	K1	PRO-57B
UT	W6RCL/7	4130	59	10	0	LT5	20	1.5	FT817	Dipole
VA	K3SS	28525	163	25	0	LT5	80,40,20,15	3.5	FT757GX	Inv vee @ 35'
	K4AHK	24756	124	17	10000	LT5	40,20	2.5	K1	Attic dipoles
	KK4R	24360	121	16	5000	LT1	40	2.5	NC40A	130' dipole
	WA4CHQ	12560	84	9	5000	LT1	40	2.2	HB 40m xcvr	Doublet
	N7RI	9860	54	9	5000	LT1	40	4	K2	Inv vee
WI	N9NE	193000	400	60	25000	LT5	80,40,20,15,10	4	K2	Doublet, tribander
	WA9PWP	7688	48	8	5000	LT5	15	1.5	K1	Carolina window 80
WV	N8BL	41756	148	21	20000	LT5	80,40,20,15	4	K2	80 m horiz loop @ 50'
WY	W7AJK	35	5	1	0	LT5	20	0.1	TS-570D	Dipole

cabin. Forgot NC-40 and MS-15 at home. **KK4R**—Hadn't been on the air for months, so this was especially fun. **KG2H**—Band conditions were really lousy, mostly a high level of QRN. I had to really struggle to get WB8ZWW. **N7RI**—Set up in the back yard for a cool, misty evening of fun. Tried out my new TI-92+ logging program for the HB sprint.

Worked great! **VE7SL**—Missed the first hour; conditions not great but had fun with the Tin. Also picked up states #45 and #46 for the 20M Tin (WI and SD) so it was well worthwhile! **K5ZTY**—Our daily T-Storms here made the QRN pretty high but there were plenty of good signals to work. Got to work KD1JV. Always fun to work a guy that designs, builds and operates them.

**W2AGN**—Conditions seemed poor on 20 and above. 40 was excellent. Checked 10 and 160 for the extra HB bonus, but no good. **W6RCL/7**—I had to be in Salt Lake on business, so I put out a dipole antenna—hanging one leg vertically from the hotel room balcony, and winding the other around the rock facade of the building. **WA4CHQ**—Could have probably taken

1st place for VA if my QRP/bud-KK4R hadn't been trying to rag-chew with me during the sprint!! HI! **NØUR**—It was fun being "fresh meat" for the 40 minutes I was able to get on. **K1HJ**—Only able to join in for the last hour. Tried to find somebody on 15 but didn't find anybody around by that point. 20 seemed OK—was able to work VE7SL on the other side of the continent. **WJ4P**—Conditions on 15 and 20 meters were miserable and 40 meters was hot except for the S9+ "buzz-saw" noise locally. I worked stations on 40 when it would take a break! **N9NE**—

Worked K7RE in SD (strong on 3 bands); KØFRP FB from MD; AL7FS's new K2 on 2 bands; VE7SL's nice signal on 20 mtrs with his TT; NØTU's 599 20 mtr signal with 700 mW. **NK6A**—15 meters was pretty spotty here all afternoon but managed to work Hawaii off the back of the beam and managed Alaska (thanks Jim). **KG4FSN**—Conditions were not so good here in south FL but had a lot of fun. The dipole in my living-room worked FB for what it is. **W5KDJ**—Great contest. **AL7FS**—This was the first day of operation for my K2. Contacts were from all

over the US with almost every QSO counting as a new S/P/C. I operated on both 20 and 15 meters. **K3HX**—More great fun! Will operate more multiband next time. **K7RE**—A real kicker was to work NN7T who said that he wasn't in the contest, but that he was coming to the Sturgis motor cycle rally in a few weeks. That event increases the population of Sturgis from below 10,000 to well over 125,000 for one week or more! **WØPWE**—Another fun contest with lots of FB HB signals on the air. Had other commitments so I just played on 20M for a little while. ●●

## Contest Announcements

### 2002 Running of the Bulls

This is a "mini-contest" coincident with the ARRL CW Sweepstakes.

#### Date/Time:

November 2, 2100Z through November 4, 0300Z, 2002

#### Goal:

To encourage more participation in the QRP category of the CW Sweepstakes. We are trying to get more QRP entries than high power ones.

#### The Plan:

1) Sign up as a BULL—Bulls are QRP stations that attempt to work 15 hours

or more and call CQ. Score is number of Q stations worked

2) Sign up as a MATADOR—Matadors are QRP stations that work as many of the Bulls as possible. Score is the number of Bulls worked.

Both groups send your entry to ARRL. All other contest rules same as ARRL Sweepstakes.

Sign up as a Bull or a Matador after October 15, 2002. A list of Bulls and Matadors will be posted on the QRP ARCI Contest Page.

We will attempt to get Bulls from each of the 80 ARRL sections.

Use the QRP ARCI on line reporting form at <http://personal.palouse.net/rfoltz/arci/form.htm> to send your score and soap-box comments.

Send QRP ARCI contest entries (summary sheet, no logs) within 30 days of contest date to:

Randy Foltz, K7TQ  
809 Leith St  
Moscow, ID 83843

or e-mail ASCII-text entries to [rfoltz@turbonet.com](mailto:rfoltz@turbonet.com)

### How to Operate the Contest: Running of the Bulls

**Date:** November 2 2100 Z through November 4 0300Z. This is a "piggyback" on the ARRL Sweepstakes CW contest.

**How to participate:** Notify QRP ARCI contest manager if you want to be a Bull (send CQ). (No need for this if you want to be a Matador by answering CQs.) Work the ARRL Sweepstakes contest as a QRP operator. Send your report to the ARRL and to QRP ARCI contest manager.

**What to send:** Follow the ARRL contest by sending a consecutive serial number representing how many contacts you have made in the contest, a 'Q' for QRP, your call, the last two digits of the year you were first licensed, and your ARRL section abbreviation.

**Best reason to participate:** So that there will be more QRP entries than high power entries.

**Relative challenge:** Difficult! (Faster code speeds, long duration, 100 W and 1 kW participants).

**Scoring:** Number of 'Bulls' you contact for 'Matador' stations. Number of 'Q' stations you contact for 'Bull' stations.

### 2002 Holiday Spirits Homebrew Sprint

#### Date/Time:

December 1, 2002, 2000 Z through 2400 Z. CW only.

#### Exchange:

Members—RST, State/Province/Country, ARCI number  
Non-member — RST, State/Province/Country, Power output

#### QSO Points:

Member = 5 points; Non-member, different continent = 4 points; Non-member, same continent = 2 points

#### Multipliers:

SPC (State/Province/Country) total for all bands. The same station may be worked on more than one band for QSO points and SPC credit.

#### Power Multiplier:

0 - 250 mW = x15  
>250 mW to 1 W = x10  
>1 W to 5 W = x7

Over 5 W = x1

**Bonus Points for Homebrew Gear:**

(Per band) Add 2,000 points for using HB transmitter, add 3,000 for a HB receiver, or add 5,000 for a HB transceiver. If you built it, it is homebrew!

**Suggested Frequencies:**

160M	1810 kHz
80M	3560 kHz
40M	7040 kHz
20M	14060 kHz
15M	21060 kHz
10M	28060 kHz

**Score:**

Points (total for all bands) x SPCs (total for all bands) x Power Multiplier + Bonus Points.

Entry may be All-band, Single-, High-, or Low-band. Entry includes a copy of logs and summary sheet. Include legible name, call, address, and ARCI number, if any. Entry must be received within 30 days of contest date. Highest power used will determine the power multiplier.

The final decision on all matters concerning the contest rest with the contest manager.

Entries are welcome via e-mail to rfoltz@turbonet.com or by mail to

Randy Foltz  
809 Leith St.  
Moscow, ID 83843

After the contest send your Claimed

Score by visiting <http://personal.palouse.net/rfoltz/arci/form.htm>. You must still submit your logs by either e-mail or regular mail if you use the High Claimed Score form. Check the web page for 10 days after the contest to see what others have said and claimed as their scores.

**2002 Top Band CW & SSB Sprint**

**Date/Time:**

December 4-5, 2002, any consecutive 4 hours between 6 pm and 6 am local time.

**Exchange:**

Member — RS(T), State/Province/Country, ARCI number  
Non-member — RS(T), State/Province/Country, Power out

**QSO Points:**

Member = 5 points; Non-member, different continent = 4 points; Non-member, same continent = 2 points. You may contact the same station only once regardless of mode.

**Multiplier:**

SPC (State/Province/Country) total for both modes.

**Power Multiplier for CW:**

0 - 250 mW = x15  
>250 mW to 1 W = x10  
>1 W to 5 W = x7  
Over 5 W = x1

**Power Multiplier for SSB (PEP):**

0 - 500 mW = x15  
>500 mW to 2 W = x10

>2 W to 10 W = x7

Over 10 W = x1

Use the smaller multiplier if you operate mixed mode

**Suggested Frequencies:**

CW	1810 kHz
SSB	1910 kHz

**Score:**

Points (total for both modes) X SPCs (total for both modes) X Power Multiplier.

Entry may be CW, SSB, or mixed mode. Entry includes a copy of logs and summary sheet. Include legible name, call, address, and ARCI number, if any. Entry must be received within 30 days of contest date. Highest power used will determine the power multiplier.

The final decision on all matters concerning the contest rest with the contest manager. Entries are welcome via e-mail to rfoltz@turbonet.com or by mail to

Randy Foltz  
809 Leith St.  
Moscow, ID 83843

After the contest send your Claimed Score by visiting <http://personal.palouse.net/rfoltz/arci/form.htm>. You must still submit your logs by either e-mail or regular mail if you use the High Claimed Score form. Check the web page for 10 days after the contest to see what others have said and claimed as their scores. ●●

**How to Operate the Contest: Holiday Spirits CW Sprint**

*Date:* December 1, 2002 from 2000 Z to 2400 Z

*How to participate:* Get on any of the HF bands except the WARC bands and hang out near the QRP frequencies of 3560, 7040, 14060, 21060 and 28060 kHz. Work as many stations calling CQ QRP or CQ TST as possible, or call CQ QRP or CQ TST yourself. You can work a station again on a different band.

*What to send:* Give a signal report and your state (for Americans), province (for Canadians), or country (for everyone else), and QRP ARCI member number if you have one, or your power if you don't have one.

*Best reason to participate:* You can pickup needed states for 2x QRP WAS in one afternoon.

*Relative challenge:* Easy for all. (Slower code speeds, short duration, good number of participants, QRP only contest).

*Scoring:* Standard QRP ARCI method for CW contests

**How to Operate the Contest: Top Band Sprint**

*Date:* December 4-5, 2002 for any consecutive 4 hours between 6 pm to 6 am local time.

*How to participate:* Get on 160M around 1.810 for CW or around 1.910 for SSB. Avoid 1.830 to 1.835 which is the DX window. You can work a station on either CW or SSB, but not both.

*What to say:* Give a signal report and your state (for Americans), province (for Canadians), or country (for everyone else), and QRP ARCI member number if you have one, or your power if you don't have one.

*Best reason to participate:* A warm up for the ARRL 160M contest the following weekend. The only mixed mode QRP ARCI contest.

*Relative challenge:* Moderate (160M is not an easy band).

*Scoring:* Mix of standard QRP ARCI method for CW contests and SSB contests.



# Review: Outbacker Joey Antenna System

David Gilson—KD3EM

Well, I just received my Outbacker Joey Antenna System and the Micro-Mount System in the mail today. I have to admit, they certainly appear to be made for each other. I know that there have been a couple of articles that have been written about the Joey, but none of them seem to me to completely hit the mark, so I'm going to try to fill in the blanks from a "field user's" viewpoint.

The "Introduction" is a general overview of the antenna system, while the "Description of Components" provides a short overview of the Outbacker Joey and its different parts.

## Tune-Up and Operation.

As we have all read in the various radio magazines, the Outbacker Joey is designed to be used in conjunction with low power portable transceivers (20 watts PEP Max). A right angle PL-259 adapter to mount the antenna on the rear of the transceiver is recommended, and is included. It's not recommended that the antenna be used portable when connected to front mounted

BNC type sockets, as physical damage to the front panel may occur. The Joey is 50 inches long, and it would be a excessive load for a BNC connector.

When attempting to tune the antenna, stand as far away from the unit as possible, as the proximity of the human body to the antenna will alter the antenna resonance. The manual clearly states, "All measurements at manufacture were achieved with the unit placed on dry-hard ground with a 12' counterpoise attached."

Attach the antenna to the SO-239, and the counterpoise to the grounding screw on the back of the rig. Set the Stinger to the scribe point marked on the it. (Note: there are two scribe marks, one at 13 inches, and one at 4 inches. The 13-inch mark is used for HF and two meter use, and the 4-inch mark is used when operating on six meters). The scribe marks are a little difficult to see, but when adjusting the stinger you can feel the marks as the stinger moves through the knurled locking nut. Since I feel over time the scribe marks will wear down enough to where you can't feel them,

I took a marker and highlighted the marks (but it really isn't necessary).

## The Micro Mount System.

This is specially designed for the Outbacker Joey, but it seems completely suitable for use with other similar antennas. The system consists of a tripod base molded from durable fiber-reinforced resin, a velcro mounting strap, an SO-239 adapter with bracket, and a 16.5 foot counterpoise. All hardware is stainless. The counterpoise is about the same size and shape as de-soldering braid. (Note: I was looking through an old "Campmor" Catalog when I came across an item described as "Ultrapod 2." This seems to be the same tripod that the Micro Mount System uses if someone was up to the task and wanted to make their own (it doesn't look all that difficult, just a little time consuming).

Listed below are SWR measurements on all of the HF bands with the stinger set at the 13-inch mark (and with no other tuning done). I didn't get a chance to check out SWR on 6 or 2 meters. ●●

<b>10 meters</b>		21.260	1.4:1	<b>30 meters</b>		7.100	1.1:1
28.000	2:1	21.300	1.4:1	10.100	1:1	7.125	1.1:1
28.200	2:1	21.400	1.4:1	10.110	1:1	7.150	1.2:1
28.400	2:1	21.440	1.5:1	10.120	1:1	7.175	1.5:1
28.600	2:1			10.130	1.1:1	7.200	2:1
28.800	2:1	<b>17 meters</b>		10.140	1.2:1		
29.000	2:1	18.068	1:1	10.150	1.2:1	<b>75 meters</b>	
29.400	2:1	18.088	1:1			3.750	5:1
29.600	1.7:1	18.108	1.1	<b>40 meters</b>		3.825	5:1
		18.128	1.1:1	7.000	5:1	3.850	4:1
<b>12 meters</b>		18.148	1.1:1	7.100	5:1	3.975	4:1
24.890	2:1	18.168	1.1:1	7.120	4:1	4.000	5:1
24.910	2:1			7.140	3:1		
24.930	2:1	<b>20 meters</b>		7.180	2.5:1	<b>80 meters</b>	
24.950	2:1	14.000	1.5:1	7.200	2:1	3.500	5:1
24.970	2:1	14.040	1.5:1	7.220	1.5:1	3.650	5:1
24.990	2:1	14.060	1.4:1	7.240	1.3:1	3.675	4:1
		14.080	1.4:1	7.260	1.1:1	3.700	5:1
<b>15 meters</b>		14.100	1.3:1	7.280	1:1	3.725	5:1
21.000	1:1	14.140	1.3:1	7.300	1:1		
21.040	1:1	14.160	1.2:1			<b>75/80 meters</b>	
21.080	1.1:1	14.200	1.2:1	<b>40 meters</b>		(with stinger all the way out)	
21.120	1.1:1	14.220	1.1:1	(stinger all the way out)		I couldn't get the SWR	
21.160	1.1:1	14.260	1.1:1	7.000	2.5:1	below 4:1 on 80 meters direct,	
21.180	1.2:1	14.320	1.1:1	7.030	1.7:1	and 2:1 is the lowest using a	
21.220	1.2:1	14.350	1.1:1	7.060	1.5:1	tuner for 75/80 meters.	

QRP ARCI is now taking membership applications and renewals via credit card—*online*—using the **PayPal** system. In fact, we prefer it—this is true for all applicants—worldwide! Simply go to the club website: <http://www.qrparci.org/us2signup.html> and follow the instructions. Be sure to select the appropriate button for the area of the world you reside in (per box below).

PayPal replaces all previous methods of payments for non-US hams, except that you may always send your payment directly to Mark Milburn, our Treasurer. *Funds must be drawn on a U.S. bank and be in U.S. dollars.* Make checks out to: QRP ARCI.

If mailing your application (if renewing, it helps to send in the mailing label from your *QO*), send it to:

**QRP ARCI**  
117 E. Philip St.  
Des Moines, IA 50315-4114

Need an Information Pack? Send e-mail to [k3tks@abs.net](mailto:k3tks@abs.net), or send an SASE to:

**Danny Gingell, K3TKS**  
3052 Fairland Rd.  
Silver Spring, MD 20904-7117

- TIPS:
1. Use the Online Member Lookup feature to keep track of your membership status—check: <http://www.qrparci.org/lookup.html>
  2. Is your data on file now correct? Use the online form to send info to our database manager: <http://www.qrparci.org/>

US—\$15 • Canada—\$18 • Non-US/VE—US\$20 per year

## New Member or Renewal Form

CALL \_\_\_\_\_ QRP ARCI# (OR "NEW" IF NEW MEMBER) \_\_\_\_\_

FULL NAME \_\_\_\_\_

MAILING ADDRESS \_\_\_\_\_

CITY \_\_\_\_\_ STATE/COUNTRY \_\_\_\_\_

POSTAL CODE (ZIP+4 FOR USA) \_\_\_\_\_

PREVIOUS CALLSIGN(S) (IF ANY SINCE JOINING) \_\_\_\_\_

(THE FOLLOWING IS OPTIONAL AND IS NOT RELEASED TO OTHERS)

E-MAIL ADDRESS \_\_\_\_\_

COMMENTS \_\_\_\_\_

### **Become a Famous Author! Write a Review for QRP Quarterly**

Have you just purchased a new gadget, rig or kit that you would like to tell the QRP world about? Then write a review and send it to the *QRP Quarterly!* Reviews are handled by our Special Features Editor, Larry East—W1HUE (see page 3 for address). We have no strict guidelines for reviews, but we do ask that you include the manufacturer's basic technical specs and any results of technical tests that you have performed. If you are not sure about some aspects of the device that you are reviewing, don't guess; ask the manufacturer for clarification. (We reserve the right to also contact the manufacturer for additional details or clarification.) Please try to be as objective as possible; tell about the good as well the bad features. Larry prefers to receive articles in machine-readable form, as ASCII text files on PC format floppy disks or as e-mail attachments.

If you want to send word processor files, Larry can handle MS Word 6/95/97/2000, Word Perfect 5/6 and Rich Text Format (RTF) formats. Please don't do any fancy formatting or embed graphics within WP files! Figures (drawings and photographs) can be supplied as "hard copy" (good quality B&W or color prints for photographs) or as digitized images (check with the Editor for acceptable formats). If you want your disks, drawings, etc. returned, please enclose an SASE with sufficient postage. ●●

## QRP ARCI STAFF

President  
**Joe Spencer—KK5NA**  
3618 Monridge Ct.  
Arlington, TX 76016  
[kk5na@quadj.com](mailto:kk5na@quadj.com)

Vice President  
**Dick Pascoe—GØBPS**  
Seaview House, Crete Road East,  
Folkestone, Kent, CT18 7EG, UK  
[g0bps@gqrp.com](mailto:g0bps@gqrp.com)

Secretary/Treasurer and  
Membership/Subscription Renewal  
**Mark Milburn—KQØI**  
117 E. Philip St.  
Des Moines, IA 50315-4114  
[mark.milburn@juno.com](mailto:mark.milburn@juno.com)

Membership Chairman  
**Steve Slavsky—N4EUK**  
12405 Kings Lake Dr.  
Reston, VA 20191-1611

Awards Manager  
**Thom Durfee—W18W**  
3509 Collingwood Ave. SW  
Wyoming, MI 49509  
[wi8w@arrl.net](mailto:wi8w@arrl.net)

Contest Manager  
**Randy Foltz—K7TQ**  
809 Leith St.  
Moscow, ID 83843  
[rfoltz@turbonet.com](mailto:rfoltz@turbonet.com)

Past Presidents  
**Jim Stafford—W4QO**  
[w4qo@arrl.net](mailto:w4qo@arrl.net)  
**Mike Czuhajewski—WA8MCQ**  
[wa8mcq@comcast.net](mailto:wa8mcq@comcast.net)  
**Buck Switzer—N8CQA**  
[n8cqa@att.net](mailto:n8cqa@att.net)

## BOARD OF DIRECTORS

**Tom Dooley—K4TJD**  
4942 Dock Ct.  
Norcross, GA 30092  
[tdooley@attbi.com](mailto:tdooley@attbi.com)

**Ken Evans—W4DU**  
848 Valbrook Ct.  
Lilburn, GA 30247  
[w4du@bellsouth.net](mailto:w4du@bellsouth.net)

**George (Danny) Gingell**  
3052 Fairland Rd.  
Silver Spring, MD 20904-7117  
[k3tks@abs.net](mailto:k3tks@abs.net)

**Hank Kohl—K8DD**  
2130 Harrington Rd.  
Attica, MI 48412-9312  
[k8dd@arrl.net](mailto:k8dd@arrl.net)

**Jim Larsen—AL7FS**  
3445 Spinnaker Dr.  
Anchorage, AK 99516-3424  
[al7fs@arrl.net](mailto:al7fs@arrl.net)



# FT-817 W4RT Accessories FT-897 FT-100/D Electronics Proven Performance FT-847

Want Both CW & SSB FILTERS Together In Your FT-817?

## One-Board Filter™

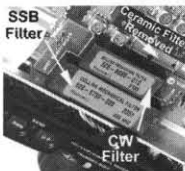

**\$299<sup>95</sup>**  
Installed  
Collins  
Mechanical  
Filters  
500-Hz CW  
2.3 kHz SSB

## FT-817 Collins Filters Low Prices



• 500-Hz CW - \$124<sup>95</sup>  
• 2.3 kHz SSB - \$139<sup>95</sup>

- Excellent CW Selectivity • Clearer Speech
- More TALK POWER • Great for PSK31

## Expedition Packs



- Backpack Style
- Rugged Water Resistant Shell
- Space for Radio, Tuner, Battery, Antenna, & More

EP-I for FT-817: \$96<sup>95</sup>  
EP-II for FT-100 & Icom 706: \$106<sup>95</sup>

## Portable Antennas

- Buddipole Modular System (see web site for items & pricing)
- MinuteMan 20: 10-20 m \$119<sup>95</sup>

## Ultimate FT-847 & FT-100/D CAT Control Programs - \$75 ea



ORDER ON-LINE FAX 256-880-3866

**WWW.W4RT.COM**

## FT-817 Power Pack One-Plug Power™

1800 mAh - Fast Charging



- Replaces Battery Cover Door
- 1800 mAh NiMH Batteries
- Use Internal FT-817 or External Battery Charger
- Over-Temp Protection
- Over-Current Protection

## FT-897 Options

- One-Touch Tune
- 4500 mAh Battery
- CW & SSB Filters

## ZAP Checker

Field Strength  
Meter Covering  
10-4500 MHz \$88<sup>95</sup>



- \$44<sup>95</sup>/yr GOWIN QSL Routing Program
- Manager ID
- DXpeditions Alerts
- Updated Weekly
- Most Accurate

## Package Deals



LDG Z-11  
AUTOTUNER  
\$180

- Full Features Control
- Memory Mgt
- Spectrum Scope
- Satellite Tracking Interface
- Voice Keyer
- Remote Control
- And MUCH MORE!

One-Touch Tune™  
Compatible



LDG RT-11 &  
FT-100/D or 897  
One-Touch Tune \$259<sup>95</sup>

Combo of Z-11  
& One-Touch Tune  
All Cables Included

Autotuners Purchased  
from W4RT Electronics  
are One-Touch Tune  
Compatible

**\$264<sup>95</sup>**  
LDG AT-11MP &  
FT-100/D or 897  
One-Touch Tune

## Speech Compressor One BIG Punch™ \$49<sup>95</sup>

Works with FT-817, FT-100/D, FT-847,  
FT-897, FT-1000MP, & Many Others

- Increase Your Real Talk Power
- User Installed Inside Your Mic
- Optional Installation by W4RT
- MH-31 Tone Switch Selects Normal or Compressed Mode
- Great Audio with BIG PUNCH
- Add the Heil HC-4 with the OBP in the MH-31 Microphone for Super PUNCH

## Tuning Made Simple

### FT-817 One-Touch Tune™

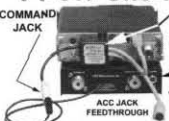

**\$59<sup>95</sup>**  
Works GREAT with the  
LDG Z-11 Tuner  
Just Press the Z-11  
Tune Button!

With the One-Touch Tune, No More Having to Change  
the FT-817's Mode to Obtain a Tuning Carrier!

### FT-100/D One-Touch Tune™

Solves the FT-100/D & FT-897 Tuning Problem.  
Works Great with the LDG AT-11MP & RT-11.

### TS-50 One-Touch Tune tool

One-Touch Tune™ Also Works  
With Any Manual Tuner!

Shipping Additional

# Ball Dog Iambic Key \$24<sup>95</sup>

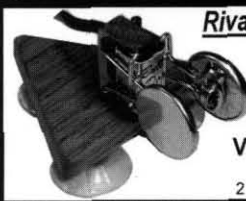

Rivals the feel of full size keys!

1oz, 2"W x 2.5"L x 1.5"H  
Adjustable spacing & tension  
3' pre-wired cable with 1/8" plug

**Money Back Guarantee!**  
Visa/Master Cards Accepted

S&H only \$3.50  
2 So. 872 Wagner Rd. • Batavia, IL 60510

TOLL FREE 877-227-9139 AmateurRadioProducts.com

## — FAR CIRCUITS —

Printed Circuit Board Design and  
fabrication for Amateur Radio and  
hobby projects.

18N640 Field Ct.  
Dundee, Illinois 60118  
(847) 836-9148 Voice/Fax

Catalog: [www.cl.ais.net/farcir/](http://www.cl.ais.net/farcir/)  
Email: [farcir@ais.net](mailto:farcir@ais.net)

# GigaParts®

Online Superstore!

[www.gigaparts.com](http://www.gigaparts.com)

Secure On-Line Ordering

Free UPS Ground  
on orders over \$200

Own the hottest little  
radio for the coolest  
price around.



**FT-817**  
**\$CALL\***

**YAESU**  
Choice of the World's top DX'ers™

Call TOLL FREE (866) 535-4442

4925 University Drive, Suite 140  
Huntsville, Alabama 35816  
Tel: (256) 535-4442

Email: [hamsales@gigaparts.com](mailto:hamsales@gigaparts.com)  
Open Mon-Sat 10-7 & Sun 1-4

\*Price and availability subject to change



1. On the move

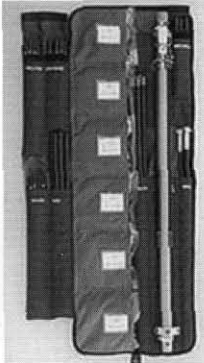

2. Pick a band



3. Getting ready

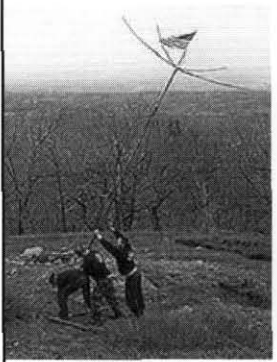

4. Up it goes



5. On the air ... less than 30 minutes!

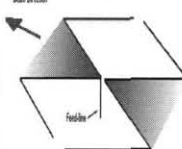

MINIATURIZED CONTROLLED FIELD ANTENNAS  
Traffie Technology  
[www.hexbeam.com](http://www.hexbeam.com)  
421 Jones Hill Road, Ashby, MA 01431-1801  
978-386-7900 Phone/Fax 1-888-599-BEAM Toll Free USA

Our K1 transceiver just became a 4-bander! With its small size, low current drain, and 5-watt+ output, the dual-band K1 was already a great rig for home or field operation. But we've taken the K1 to a new level with our KFL1-4 option, which covers 40, 30, 20, and your choice of 17 or 15 meters—all on a single plug-in module. Adding the internal auto-tuner (KAT1), internal AA battery pack (KBT1), and wide-range tilt-stand (KTS1) makes the K1 a truly "trail-friendly" radio. For more details on the K1, as well as on the K2 all-band, 15-watt SSB/CW transceiver, please visit our web site.

"My son built a K1, and was very impressed. As the ex-chief engineer of Heath, may I offer my congratulations for a kit job well done — and I should know!" — Mike Elliott, W8KRR

"This is really a kit? In my 20+ years now of playing with electronics and building kits I have NEVER seen a kit that fits together like this. It's magic." — Randy Rathbun, NV0U

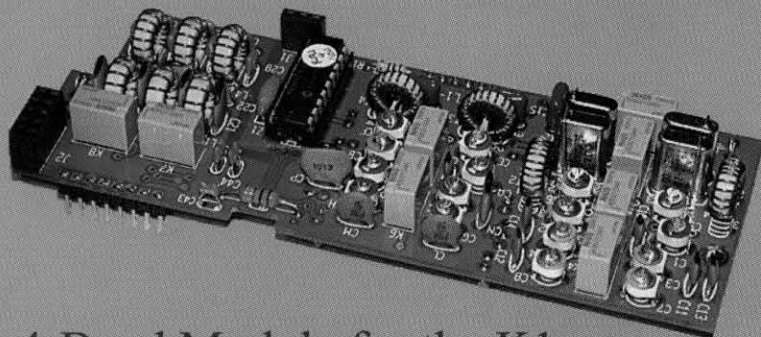

4-Band Module for the K1



[www.elecraft.com](http://www.elecraft.com)



P.O. Box 69  
Aptos, CA 95001-0069

Phone: (831) 662-8345  
[sales@elecraft.com](mailto:sales@elecraft.com)

