

Volume X No. 1

Spring 2002

QRPP



Spring
2002

Journal of the Northern California QRP Club

Table of Contents

Building the Iowa QRP-10 with Extended Frequency Range

By Frank Roberts, VE3FAO 3

A Potpourri of Audio Amplifiers

by Mike Martell, N1HFx 20

Integrated Circuit Audio Amplifiers

By Mike Martell N1HFx 23

The Club Sandwich Project

by Monty Northrup, N5FC 28

Interfacing external control software to the FT817

by Graham F Firth G3MFJ/W3MFJ 48

Building an Interface for the External Control Software to the FT817

Graham F Firth G3MFJ/W3MFJ 52

Arkiecon 2002 Diary

by Tony Fishpool, G4WIF 55

QRP Operating

By Richard Fisher, KI6SN 58

QRPacificon 2002

by Doug Hendricks, KI6DS 62

VXO Building Contest Rules 62

Rock Mite Nite at QRPacificon 64

QRPacificon Building Contest 64

From the Editor, by Doug Hendricks, KI6DS

I hope that you enjoy this issue. A nice variety of construction articles this time, plus a couple of things to make you think. I encourage all of you to read Monty Northrup's Club Sandwich Project. I would hope that it becomes the seed to bear some QRP Club Project fruit.

I also hope that you can attend Pacificon this fall, on Oct. 19, 20, and 21 at the Sheraton Hilton in Concord, CA. Be sure to ask for the convention rates when you make your reservations. We have lots of fun things planned, and hope to see you there. 72, Doug, KI6DS

Building the Iowa QRP-10 with Extended Frequency Range

By Frank Roberts, VE3FAO

After reading the article by Mike Fitzgibbon, N0MF in the Fall 2000 issue of QRPp, I decided to build the IA QRP-10 transceiver. To start, I set out a list of additional objectives, including the following:

1. Construct it to fit a standard size, easily obtained enclosure
2. Make it fully operational out of the enclosure for tuning and troubleshooting
3. Minimize the number of exposed connecting wires
4. Have all circuitry on one circuit board including the TiCK keyer.
5. Expand the VXO to cover a 50 KHz range

Note: All references to components designated 00 to 99 are based on the article by Jim Kortge, K8IQY and the schematic in Spring 2000 issue of QRPp. Components in the 100 series are for the TiCK keyer outlined in the original article, and finally components in the 200 series are additions, mainly to expand the VXO coverage.

THE ENCLOSURE WAS BUILT FIRST

A standard Ten Tec model TG 26 enclosure (1 15/16 x 6 1/4 x 4 1/8) was selected. To ensure that the circuit board, with attached controls, could be inserted and extracted from the case easily, it was necessary to drill the mounting holes in the enclosure first. With reference to Figure 1, three 7/32" mounting holes were drilled for J1, J2, and S101 as marked. I then mounted the two jacks with the soldering tabs pointing down, but not shorting to the case. The pushbutton was oriented so that its upper surface was on the same plain as the upper surfaces of the jacks.

A blank double sided 3 5/8" x 5 7/8" circuit board was tested for proper fit making sure it sat evenly on the 3 mounted components and had about 1/8" clearance from the rear of the case. The rear clearance allows the board, with J1, J2 and S101 attached, to be angled into and out of the case. The circuit board was removed and glue spread on the top of

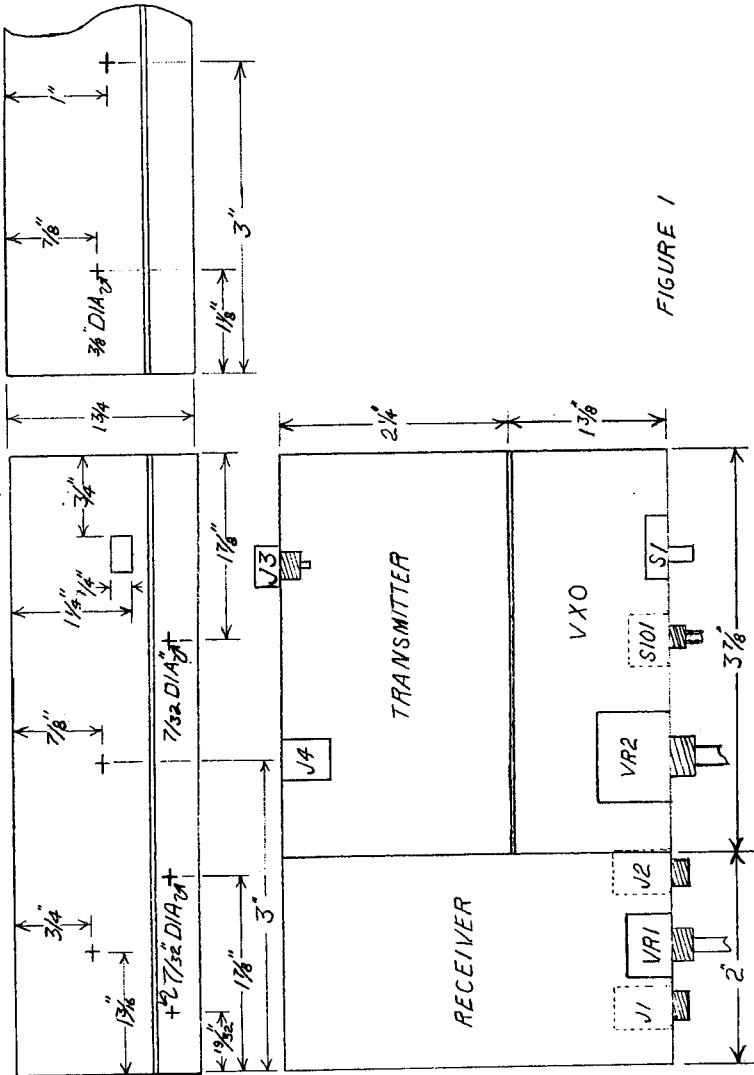

FIGURE 1

the jacks and pushbutton. Now the circuit board was pressed onto these components maintaining the clearance at the rear of the case and allowed to set. It was then possible to remove the mounting nuts from the front of the case and extract the circuit board from the case with the components securely attached to the under side.

A 3/8" hole was drilled in the centre of the front panel at a height to match the main tuning potentiometer I had selected allowing it to rest on the circuit board. With the circuit board in place and the potentiometer mounted with its casing just touching the circuit board, it was oriented so the soldering tabs were to the right and the lower ones about the thickness of the circuit board pads (nibbles) above the circuit board. I then glued the tuning control to the circuit board.

In a similar manner the hole for the band range switch was made and the switch glued to the top of the printed circuit board. I used a slide switch, but a DPDT toggle switch would work fine and could be oriented sideways so that the flat edge is glued to the circuit board.

The Gain control was mounted with its connections facing down and soldered to nibbles so I left this hole to be drilled later to match the final position of the control.

The power jack J4 was positioned on the top of the circuit board and in the centre even with rear edge. The lower mounting wing was filed off providing a flat surface so it could be glued directly to the circuit board.

Finally, the antenna jack, a BNC connector was held in place by its mounting lug soldered to the top of the circuit board and even with the rear edge and about 1 inch from the right side. The length of the ground lug determined the vertical position of the hole used to mount the BNC connector.

A CRADLE FOR THE IA QRP-10

I found it helpful to build a cradle from a piece of wood about 1 x 6 x 4 to support the circuit board when it is out of the cabinet both during construction and during alignment. Three

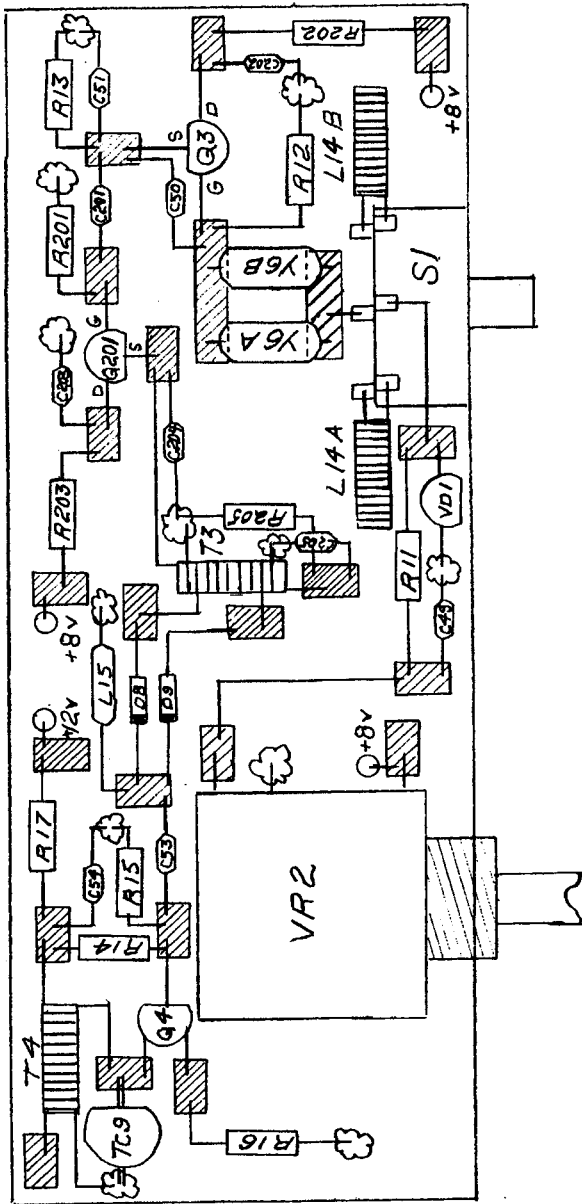

FIGURE 2

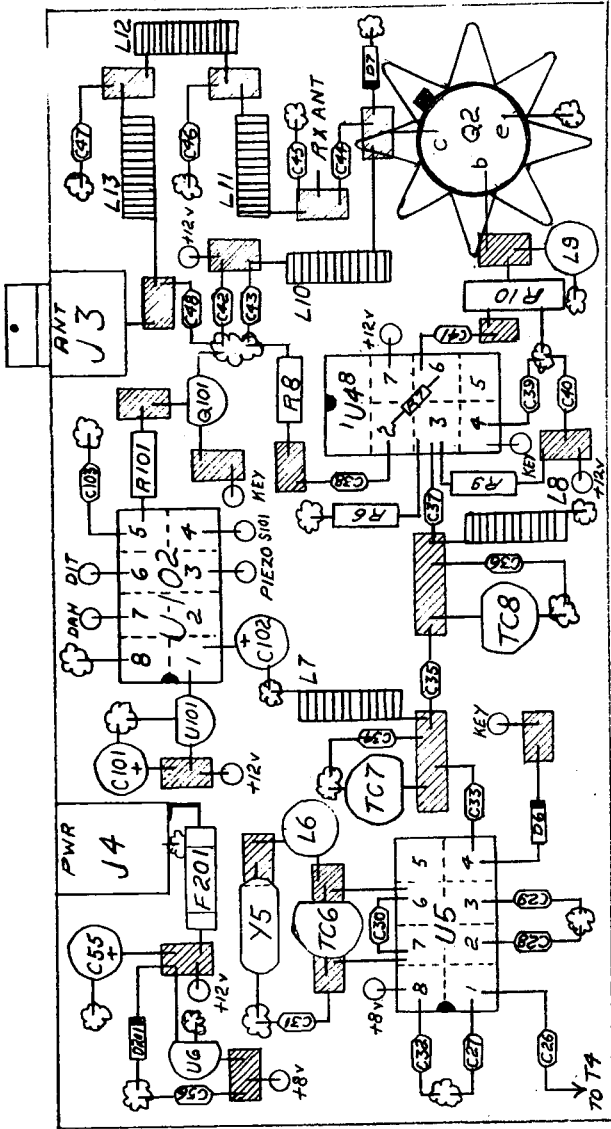

FIGURE 3

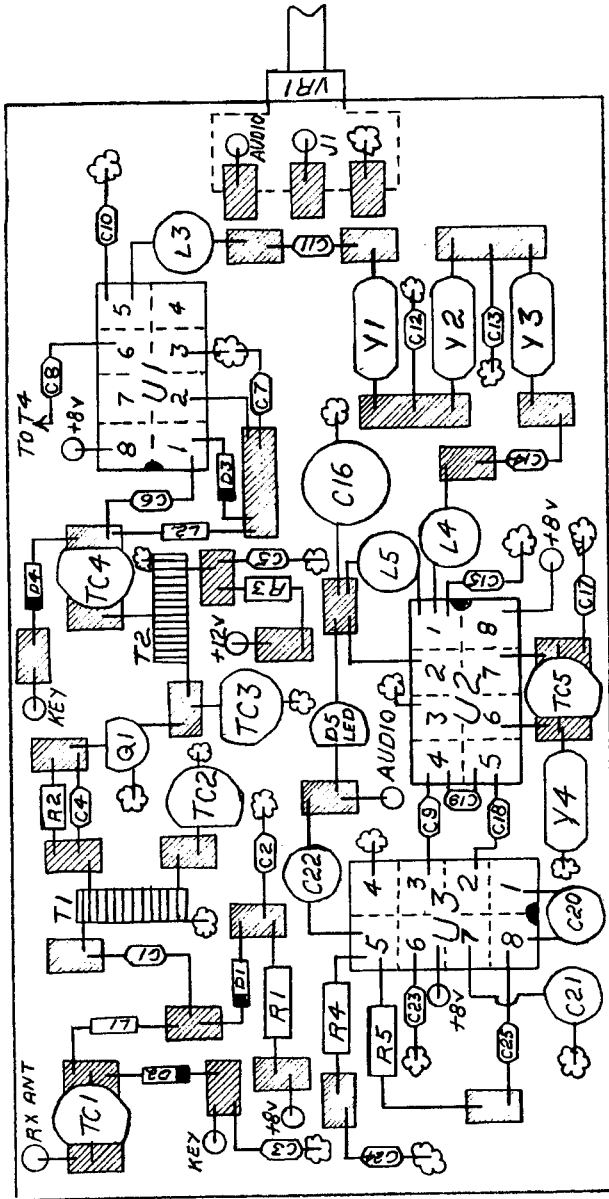

FIGURE 4

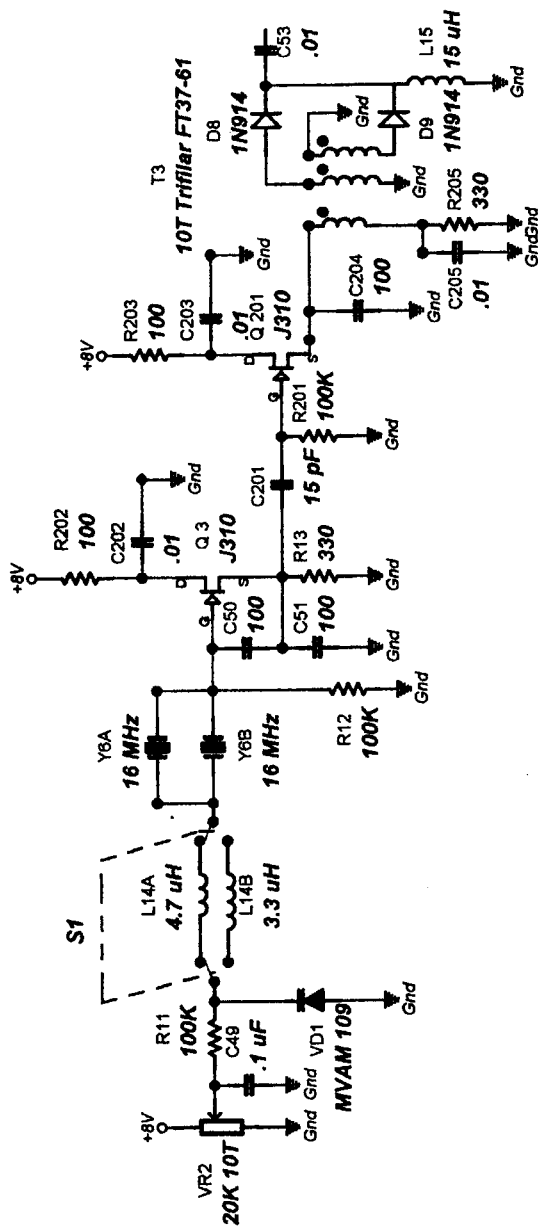

FIGURE 5

IOWA QRP 10 - VXO MOD BY VE3FAO

cut outs were made to accommodate the controls mounted on underside of the board. The cradle kept the PCB level and stable for gluing on the nibbles and met my objective to easily operate and tune the transceiver out of the case.

MINIMIZING THE EXPOSED WIRING

To reduce the number of exposed wires, all the controls and jacks were glued or soldered directly to the circuit board. J4 (DC in), VR1 (Gain Control), VR3 (Tuning Control) and S1 (Band Range Switch) are mounted on the top of the circuit board. J1 (Headphone Jack), J2 (Paddle Input) and S101 (Keyer Pushbutton) are glued to the under side of the circuit board. Both sides of the double-sided circuit board act as ground plains and had to be connected together. I used the braid salvaged from a piece of RG-174 cable.

In addition, my version of Manhattan has "Underground Utilities". All interconnecting power and signal cabling are run below the circuit board and brought up to the junction points through small holes in the board, as noted in figures 2, 3 and 4.

LAYING OUT THE CIRCUIT BOARD

The new layout combines the original three 2" x 4" boards into one 3 5/8 x 5 7/8 double sided circuit board. Each of the three sections has been oriented such that the VXO output is adjacent to its input components on the other two sections. See Figure 1.

The three main sections of the transceiver were laid out as in figures 2, 3 and 4, allowing a space the width of a double-sided circuit board between the VXO and the transmitter sections. This was to accommodate an RF/Heat shield. I initially thought it would be necessary to shield the Output transistor from the oscillator, but since the casing of the final transistor is grounded it was not necessary. I left it in as a heat shield.

With the exception of the VXO which has been rede-

signed, the component layout is a combination of the original drawings by Paul Harden NA5N in Fall 2000 issue of QRPp, ideas taken from Jim Kortge K8IQY's article in Spring 2001 QRPp and photos on the website of Chuck Adams N7QO.

I have moved the TiCK keyer from the VXO section to the transmitter section, added a fuse and a 15v zener (D201) at J4 and allowed spaces for mounting the controls right on the printed circuit board. You will notice that all the resistors are mounted in the prone position rather than being upright as in the traditional Manhattan style. This was a personal preference as I thought it better defined the streets of Manhattan. To fit everything onto one board, in a few non-critical positions I chose 1/8 watt resistors rather than the common 1/4 watt variety. A 1/4 watt resistor positioned upright would also have worked.

EXPANDING THE VXO COVERAGE

Attempts at increasing the inductance of L14 resulted in the crystal oscillator becoming unstable or not oscillating at all. The decision was made to use two 16 KHz crystals in parallel to reduce their Q and add a buffer taken from ARRL's 1977 edition of "Solid State Design for the Radio Amateur" by Wes Hayward, W7ZOI and Doug DeMaw, W1FB on page 50. I also used the doubler circuit from page 42 incorporating a trifilar wound broadband transformer for T3. The schematic of the modified VXO is shown in Figure 5.

There are three components in the VXO that have an effect on how far the coverage can be expanded - the crystal, the inductor and the tuning diode. The following experiments were conducted to optimize the selection of each of these components to achieve my goal of 50 Khz of frequency coverage.

Given a 3.932 KHz IF and the fact that the VXO is followed by a doubler circuit, Table 1 compares the target frequency range with the VXO frequency needed to obtain the

desired results.

The objective of my experiments was to select components that would yield a VXO range from 15,975 KHz to 16,000 KHz

10 M	28,000	28,018	28.060	28,068
VXO	15,962	15,975	15,996	16,000

TABLE 1

Since all 16 MHz crystals are not created equal, I took a selection of a dozen crystals and tested them individually in the VXO circuit using a 3.3 uH inductor for L14 and a 1SV149 tuning diode. Each crystal was checked for its frequency without the frequency adjusting components connected (i.e. the junction of L14 and X6 grounded). Then the inductor and tuning diode were introduced to see how far the crystal could be bent. I selected the two most flexible crystals and paired them together. See Table 2.

	VXO (0v)	Xtal Grounded
Y6a	15,996.0 KHz	16002.9 KHz
Y6b	15,997.1 KHz	16,002.6 KHz
Y6a & Y6b (parallel)	15,991.4 KHz	16,004.6 KHz

TABLE 2

The next component to be chosen was the tuning diode while keeping the selected dual crystals and the 3.3 uH inductor constant. I had randomly gathered a group of 7 tuning diodes for testing. Each type exhibited a different result, but unlike the crystals, tuning diodes of the same type gave iden-

tical results. Table 3 shows the frequency coverage of each tuning diode in KHz.

TUNING DIODE	MIN (0v)	MAX (8v)
MVAM109	15,990.3	16,000.8
MV209	16,002.6	16,009.0
MV2104	16,007.1	16,010.8
MV2105	16,006.2	16,009.5
MV2107	16,004.2	16,006.4
MV2209	16,001.6	16,004.0
1SV149 (MVAM108)	15,990.3	16,001.0

TABLE 3

The results of this experiment were surprising since several of the tuning diodes selected moved the 16 MHz crystal frequency higher rather than lower as expected. None of the tuning diodes came close to reaching the target range of 15,975 KHz to 16,000 KHz using a 3.3 uH inductor for L14. MVAM109, MV209, MV2209 and 1SV149 were chosen for the next phase since they were able to pull the crystals the furthest.

With the buffer stage added, it was now possible to increase the inductor value while still maintaining oscillation. Table 4 shows the results of various values for L14 greater than 3.3 uH.

4.0 uH INDUCTOR:

TUNING DIODE	MIN (0v)	MAX (8v)
MVAM109	15,986.6	15,997.6
MV209	16,001.6	16,008.2
MV2209	16,000.4	16,003.1
1SV149	15,986.7	16,000.4

Pictures of Frank Robert's Iowa QRP 10 in various stages of construction.

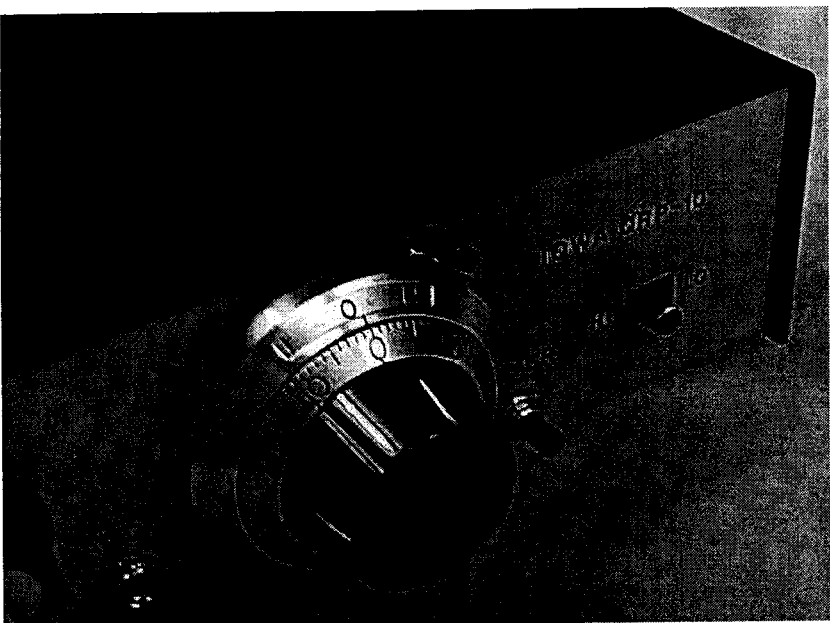
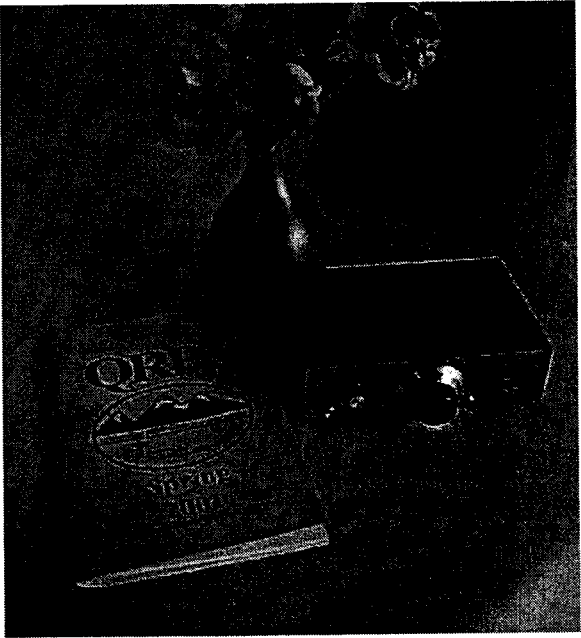

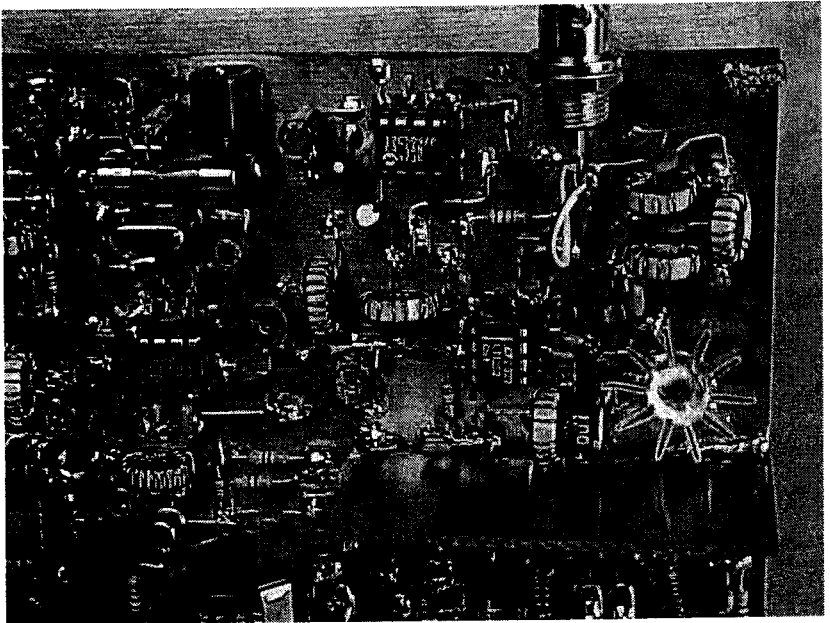
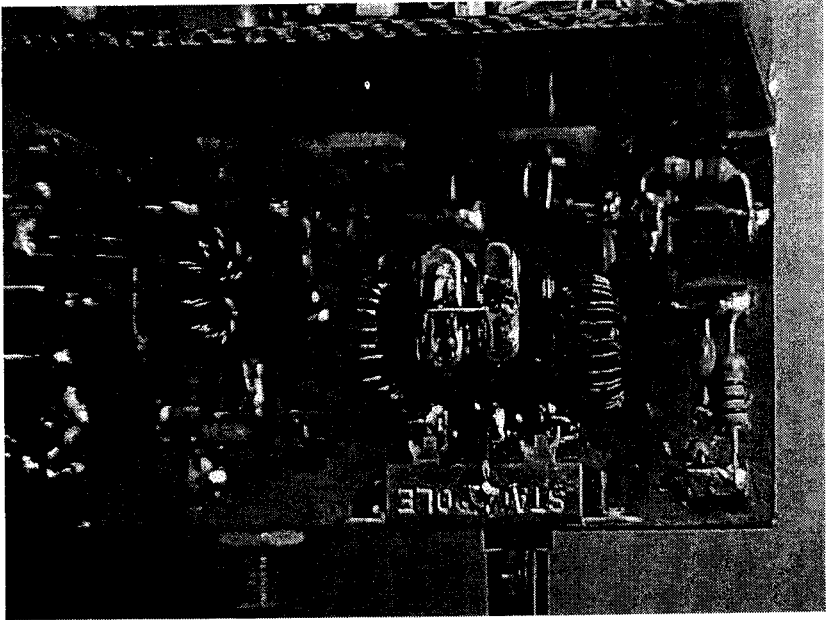

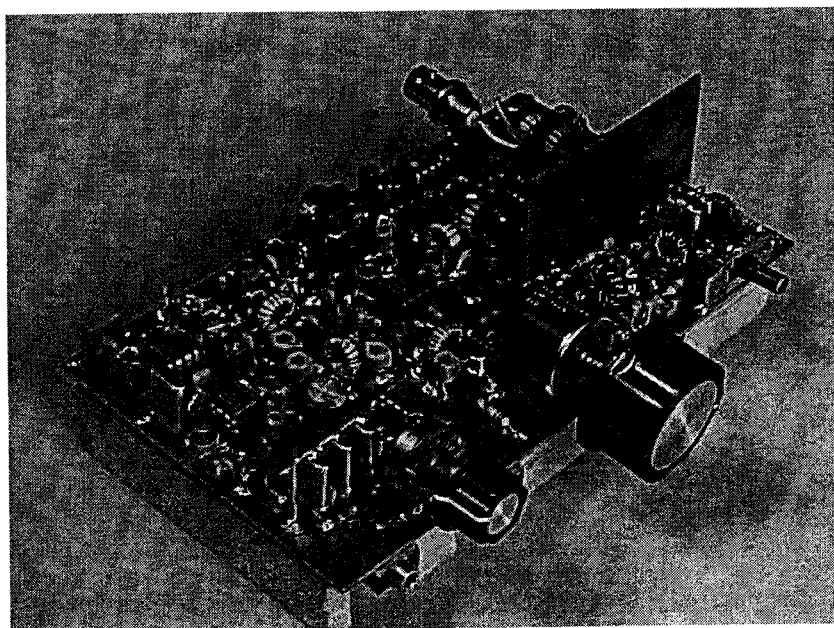
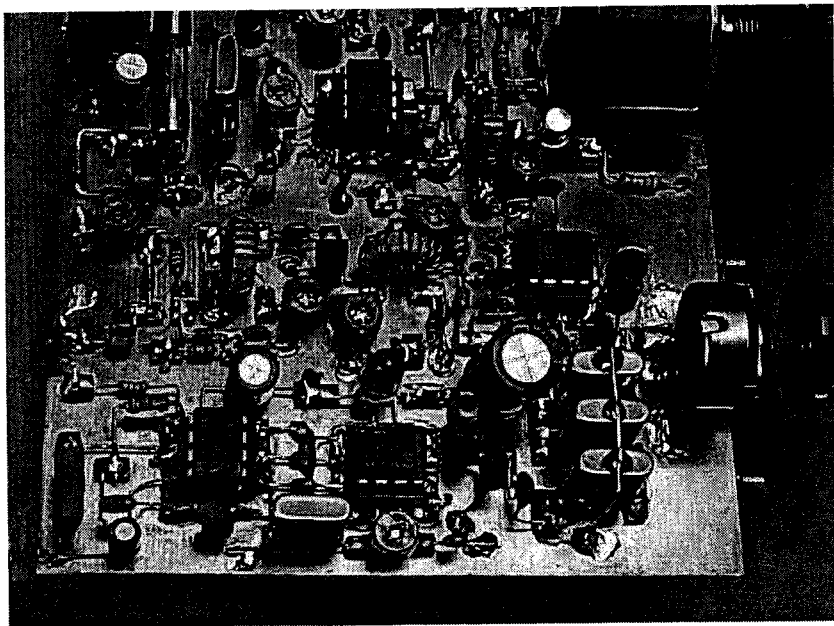

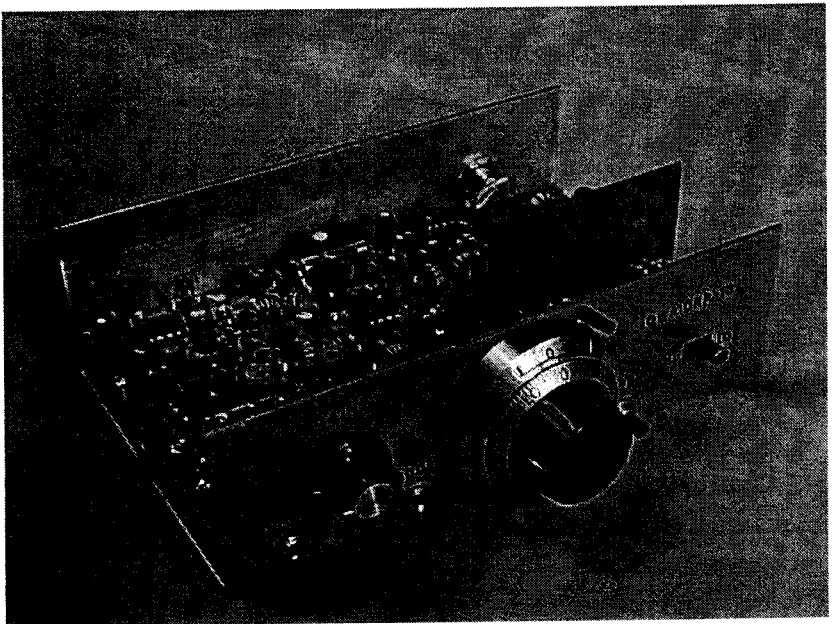
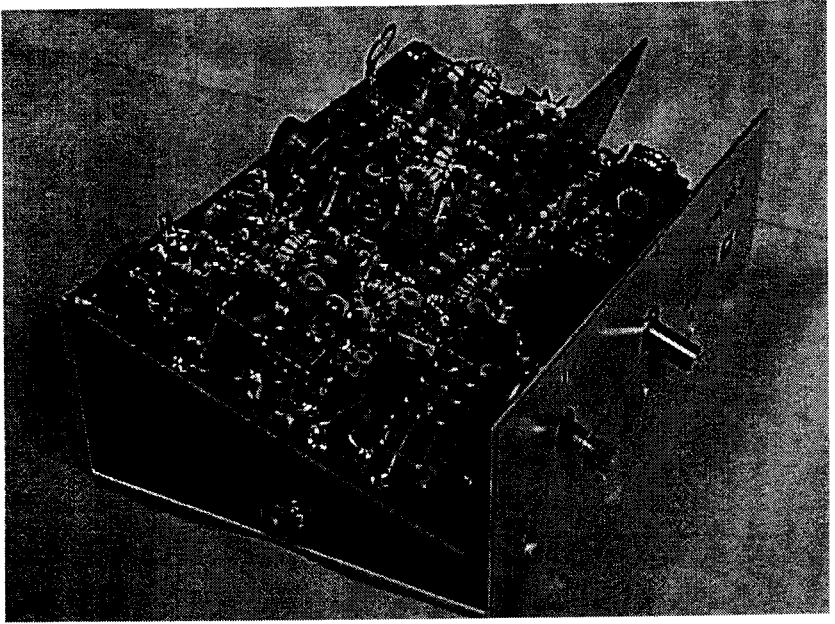

4.5 uH INDUCTOR:

TUNING DIODE	MIN (0v)	MAX (8v)
MVAM109	15,980.0	15,995.4
MV209	15,999.7	16,006.8
MV2209	15,998.3	16,001.4
1SV149	15,979.9	15,997.0

4.7 uH INDUCTOR:

TUNING DIODE	MIN (0v)	MAX (8v)
MVAM109	15,975.5	15,993.1
MV209	15,998.4	16,006.1
MV2209	15,996.9	16,000.5
1SV149	15,975.3	15,995.8

TABLE 4

Although the lower frequency objective was reached with both the MVAM109 and 1S149 tuning diodes coupled with the 4.7 uH inductor, I was hoping that I would be able to switch between two tuning diodes, as in the original design, to obtain the desired 50 KHz frequency range. Unfortunately there was no combination of tuning diodes that did not leave a gap in the coverage and worst of all, the gap fell right at 15,996.0 KHz, which relates to the QRP calling frequency.

The result of all these experiments was the realization that I could use one tuning diode instead of two and switch inductors to achieve the desired frequency coverage. Table 5 shows the results of my final selection using the MVAM109 tuning diode and switching between 3.3 uH and 4.7uH induc-

tors. Although the 1SV149 had slightly greater coverage, it displayed some instability around 15,998 KHz.

4.7 μ H INDUCTOR	3.3 μ H INDUCTOR
15,975.5 - 15,993.1	15,990.3 - 16,000.8

TABLE 5

There is a 2.8 KHz overlap that can be reduced by changing the separation of the turns on the toroids used for the inductors.

I would like to thank Jim Kortge, K8IQY for his encouragement and valuable assistance via e-mail during the building of the IA QRP-10. Also thanks go to my brother Ken, VE3BGW for his encouragement and editing during the writing of this article. I am pleased with the resulting transceiver and it is a worthy addition to my ham shack.

Frank Roberts VE3FAO

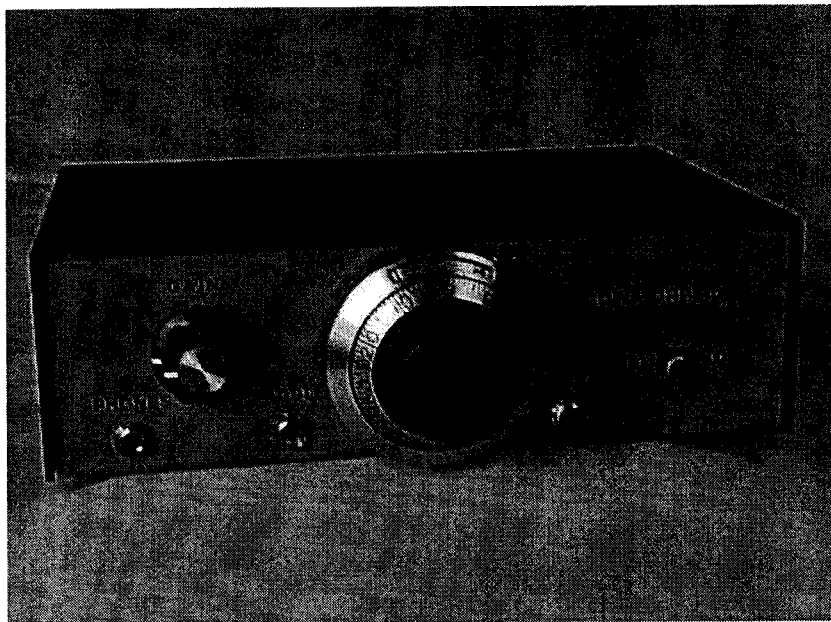

A Potpourri of Audio Amplifiers

by Mike Martell, N1HFX

At a recent RASON meeting, I gave a presentation of how to design audio preamplifiers. I thought it would be nice if we could now build some audio amplifiers to bring the output from these preamplifiers to levels which could drive a speaker. I intentionally avoided the use of IC amplifiers to provide a real learning experience for audio amplifier design. Although many IC amplifiers provide excellent performance at low cost, we need to learn the basics first. I will address IC audio amplifiers in a future article.

Figure 1 is an interesting audio amplifier which provides almost a watt of audio with a very low standby current of only 45 milliamps. This circuit is really a current repeater formed by Q2 and Q3 and driven by Q1. This circuit is similar in performance to many IC amplifiers but requires an initial bias adjustment. R2 controls the bias and should be adjusted so that exactly $\frac{1}{2}$ of the supply voltage is measured at the

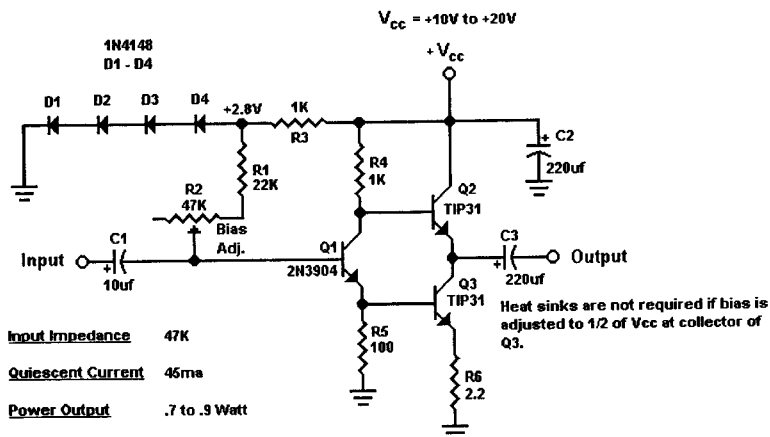

Figure 1

N1HFX
1/11/98

collector of Q3 with no signal. Once adjusted, heat sinks are not needed for Q2 and Q3 and a very high input impedance of approximately 47,000 ohms is seen at the input. Diodes D1 through D4 provide a constant voltage of 2.8 volts and form a constant current source through the base of Q1. This circuit is almost as good as some audio amplifier IC's and is preferred when a minimum power drain is needed.

The circuit in Figure 2 is a classic Class A audio am-

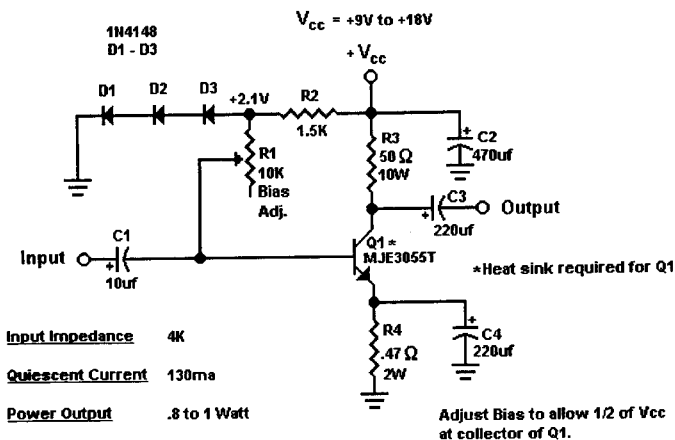

Figure 2

N1HFX
1/15/98

plifier utilizing the same biasing system as in the circuit of Figure 1. While it is possible to set the bias by using only 2 resistors, this does not give the flexibility to operate from a wide range of supply voltages. By adjusting the bias manually, we can optimize the amplifier and guarantee that $\frac{1}{2}$ of

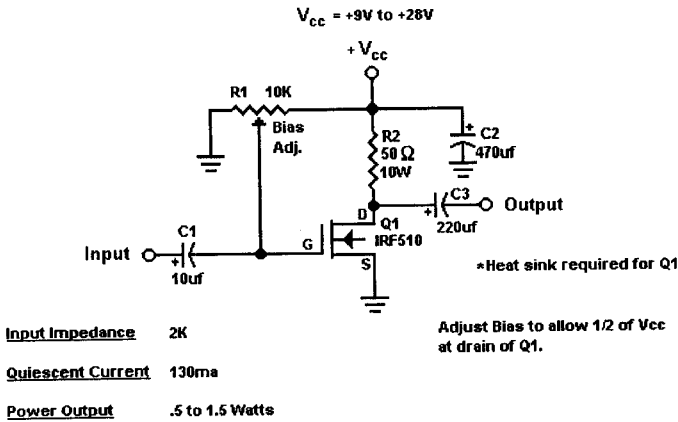

Figure 3

N1HFX
1/15/98

our supply voltage appears at the output no matter what the supply voltage is. This arrangement gives us maximum power out with minimum distortion. The circuit in figure 2 features low distortion and very low noise at the expense of a much larger standby current. Of course, this large standby current requires a heat sink for Q1. Resistor R4 prevents thermal runaway and it is bypassed by C4 to maximize gain. The actual gain obtained will vary depending on the HFE of the transistor used along with the supply voltage. I recently built two of these circuits and used them as a stereo booster amp for a portable CD player with excellent results.

The circuit in Figure 3 features a power MOSFET operating at class A. This circuit is particularly interesting because of the low parts count. The bias should be set for $\frac{1}{2}$ of the supply voltage at the drain of Q1 as in the previous circuits. There is no resistor at the source of the transistor

simply because thermal runaway is not a problem for power MOSFET's. This circuit has a large standby current requiring a heat sink for Q1. This circuit will not perform as well as the previous bipolar designs when operated at a mere 13.8 volts. At such low voltages, we can not expect more than a ½ watt of power. MOSFET's work best when operated at higher voltages and this circuit will easily give us 1.5 watts or more if we operate it at 28 volts.

I hope you enjoy building and learning about these audio amplifier circuits. All of these parts can be obtained at any Radio Shack for the faint of heart. Remember, the only way to really learn how these circuits work is to actually build one.

DE N1HFX

Integrated Circuit Audio Amplifiers

By Mike Martell N1HFX

In a previous article I discussed building audio amplifiers using discrete transistors. While it is possible to build good audio amplifiers from discrete transistors, they are no match for the many audio amp IC's available to us. IC's offer many advantages including high efficiency, high gain, low standby current, low component count, small size and ,of course, low cost. It is little wonder that audio amp IC's have replaced discrete transistors in most consumer electronic devices. While many experimenters have stayed away from these little black mysteries, I am going to uncover some of their secrets and demonstrate how easy they are to use.

Our first IC amp is listed in Figure 1 and uses a LM386 IC. The LM386 comes in 3 flavors now; LM386-1, LM386-2, LM386-3 with output power levels of 300, 500 and 700 milliwatts respectively. The type sold by Radio Shack is the LM386-1 and is the one we used in this circuit. Perhaps the most unique feature is that it is available at any Radio Shack and can operate at voltages as low as 5 volts. Just like regu-

lar op amps, audio amp IC's have an inverting and non-inverting input. Input signals are normally fed to the non-inverting input while the inverting input is normally tied to ground. Because of the high gain of IC audio amps, it is highly recommended to isolate them from the power supply to prevent oscillations. In this circuit, R1 and C1 accomplish this task very well. Resistor R3 controls the gain and Capacitor C3 couples the output to the speaker. Output capacitor coupling is mandatory in just about all IC audio amp designs.

The LM386 IC is unique in that the gain can be modified by changing Resistor R2 and Capacitor C2. This configuration will give us a gain of 20. By removing R2 and connecting C2 across pins 1 and 8, we can increase the gain to 200. It is important to understand that increasing the gain does not increase the output power. The increased gain is only used when a very low input signal is to be amplified.

Our next IC is the LM380 and it also comes in two flavors; LM380-8 and LM380 with output powers of 700 milli-watts and 2 watts respectively. Figure 2 depicts the LM380-8 and Figure 3 depicts the LM380. The LM380-8 comes in an 8 pin package and its basic circuit is virtually identical to the LM380 except for the different pin out. The LM380 comes in a 14 pin

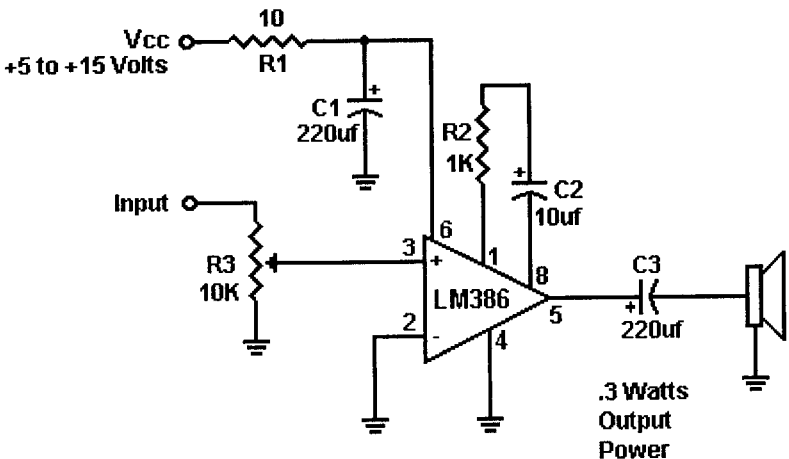

Figure 1

package and pins 3,4,5,10,11 and 13 are connected to ground to act as a heat sink. Experience has shown the LM380 should be soldered directly to the circuit board (no IC socket) if it is going to be operated at its full rated 2 watt output. This IC can become quite warm and it's important to get rid of excess heat through the pins. The primary advantages of the LM380 series IC's are higher output power, very low distortion and low external parts count

No matter how much volume, an audio amp provides, there are still those who require even more. The circuit in Figure 4 uses a LM383 IC amp and will provide up to 7 watts of output power for those who want to really experience their audio. The LM383 comes in a TO220 type package with 5 pins as indicated in Figure 4. My experiences with this IC revealed that it must be heat sunk at all times due to it's high standby current. If you plan to use this IC keep all components as close as possible to the IC and be certain that your power source can supply up to 1.3 amps of current. The main advantage to this IC is its 7 watt output which is why it

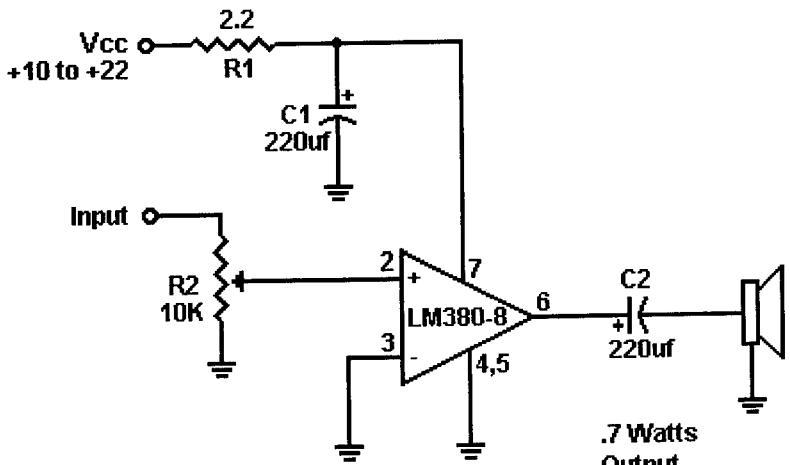
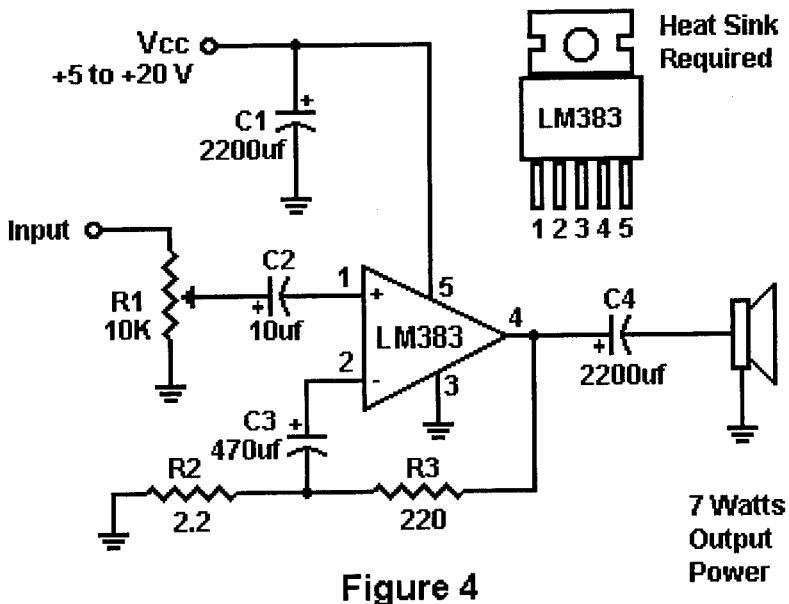
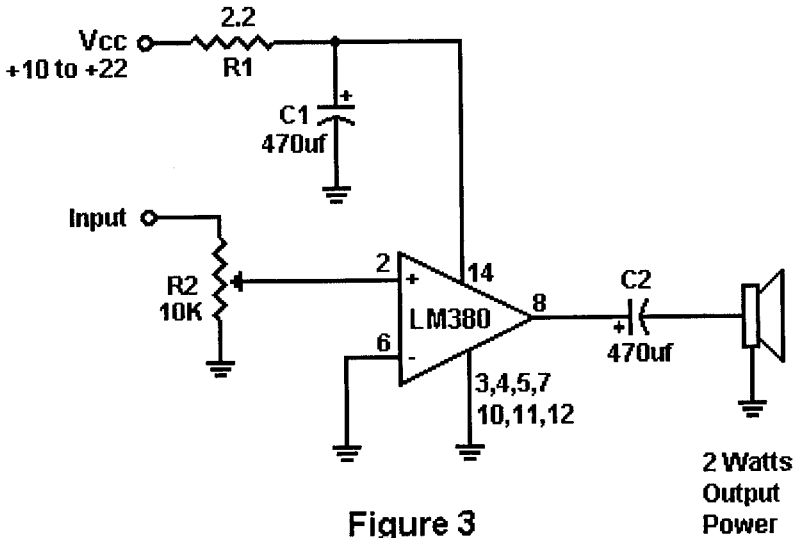

Figure 2

has found its way into many inexpensive car radios. This IC offers low distortion and is a real bargain compared to discrete transistors.

It should be apparent now that audio amp IC's have much to offer us in the way of low cost audio amp circuits.



data sheets can be easily obtained by searching the world wide web. Almost all of the major IC manufacturers now offer their data sheets to be downloaded free at their web sites. For example, check out National Semiconductor at <http://www.national.com/design/> and Motorola at <http://mot-sps.com/cgi-bin/dlsrch> for all kinds of information on a wide array of IC's and other solid state devices.

DE N1HFX

Parts Suppliers

JDR MicroDevices

1850 South 10th Street
San Jose, CA 95112-4108
1-800-535-5000
<http://www.jdr.com>

Mouser Electronics
958 North Main Street
Mansfield, TX 76063-4827
1-800-346-6873
<http://www.mouser.com>

The Club Sandwich Project

by Monty Northrup, N5FC

Recently, at our local QRP club meeting, someone joked that it would be a marvelous sight to see all our various Altoids-packaged projects connected together to form a station. We all chuckled at the visual suggestion, but later I got to thinking more along those lines.

What I propose here, as an outgrowth of that interesting suggestion, is a project I have dubbed the "Club Sandwich". As the title implies, the project is intended for amateur radio clubs. It provides a unique opportunity to exercise individual creativity under the umbrella of a team project, increase overall knowledge of radio system hardware design, and provide a continued base for experimentation in the club. The most promising and rewarding aspects, however, may well be the opportunity for increased comradery, renewed interest in club activities, and just plain ol' radio-fun. As conceived, the project is sure to interest both newcomer and old timer alike, and bring the two together.

The Club Sandwich takes the form of a simple construction project; in our example, a QRP CW transceiver. It is composed of several smaller sub-projects, representing modular functions, to eventually be connected together to form a working transceiver. Imagine a half-dozen or more Altoids boxes, interconnected with shielded cables. Larger clubs may want to consider more complex projects. When completed, it may be used for field day, or "checked out" by members for a short time.

What Kind of Project Should We Pick?

The specifics of the project should be tailored to the interests and skill-levels of the club membership. Common hardware elements should be defined, simply so everyone is on the same page, interconnection wise. Likewise, it's important to have a technical goal (sometimes called a "specification") and a plan to go with it (sometimes called a "system design"). I hesitate to use the latter terms, because in-

formality should be modal in a project like this. Aside from the specifics of the hardware and design, there are some intangible but essential elements for the Club Sandwich; we'll speak in terms of our example, a QRP CW Transceiver:

- **Modular Construction** - The transceiver is broken down into well-defined, weekend-sized construction projects (OK, sub-projects), to be constructed by individuals or small teams, in their own spare time.
- **Flexibility** - Modular sub-projects can be removed and replaced readily to facilitate experimentation and improvements.
- **Compatibility** - A system design approach ensures common elements (like interconnecting hardware, power supply voltages, and input/output specs).
- **Utility** - While the construction techniques and layout may be unconventional (or even bizarre), the transceiver will ultimately be usable, and suitable for on-the-air operations.
- **Charm** - What could be more charming than a half-dozen or dozen · Altoids-boxes linked together to form a working piece of ham gear?
- **Uniqueness** - No two "Club Sandwiches" will be alike; they will reflect the skills, ingenuity, and humor of the members of that unique club.
- **Renewability** - as time passes, modules may be added or replaced, resulting in an entirely "new" project, while re-using elements which remain suitable for the current application.

Sounds Cool! How Do We Get Started?

Begin by assigning a team coordinator. Did I say assign? OK, elect or proclaim a volunteer as your team coordinator. If at all possible, that should be a person with good people skills and broad technical experience. This is the person who will coordinate the participating members, and keep the "big picture" in mind should things go astray. Once you've selected your team coordinator, you're ready to begin.

The "system design" approach suggested here is loosely

based on proven techniques used in commercial engineering. System design consists simply of the following: Agree on the goal, formulate a plan, produce a preliminary design, implement the prototype, test and modify it, integrate the system, and document what you've got. In the case of the Club Sandwich, individual modules are designed, built, tested, and documented by individual club members on their own time (though perhaps with the help of a mentor or assistant). Integration of individual modules is done at a club meeting, so the project can be appreciated and discussed by all. Let's look at these individually:

- Agree on a Goal - Figure out (together) what your project will be. This need not be formal, but try to find something that everybody who wants to participate will enjoy, both during and after construction.

- Formulate a Plan - Let an individual with homebrewing experience (or a committee of like individuals), come up with a "plan of attack". This means figure out how to reach the intended goal, while breaking the project into bite-size pieces. A Block Diagram will suffice as the "output" of this step, with a copy going to each participating club member. An input/output specification for each module (or block) would enhance the future success and forestall a lot of unnecessary questions. The plan is considered "in place" when the majority of modules and tasks have been assigned to individuals. Again, keep in mind, all assignments are predicated on volunteerism (and I don't mean that like the Army means it). We'll address the formulation of a Block Diagram below, under another heading.

- Produce a Design - Here, the individual (or small team), breaks out the books, magazines, and the calculator, and selects or designs a circuit that will do the assigned task of the module. Quite likely, they'll put a pencil to a greasy yellow sheet of paper, and make a list of needed parts. Obviously, since there are many modules involved, there will be many individuals working independently at this point. This could take

several months, with monthly meetings being used to network with others and get help or confirmation for the design, if desired.

- **Implement a Prototype** - To do this, the individual procures parts for her/his module, and puts it together. This also could take several months, with show-and-tell of progress at club meetings. Be sure to network with others, to trade parts and minimize costs.

- **Test and Modify the Prototype** - Again, this is an individual process, performed on the individual module, and could take a while, depending on the skill levels involved. It's very important to network, via e-mail or eyeball, or at club meetings, so that individuals can successfully accomplish testing without frustration. This is an opportunity for members who have good test equipment to connect with those who do not. The outcome of testing is almost always modification, so don't be surprised when that's the case.

- **Integrate the System** - When enough modules have been constructed by individuals, it'll be time to hook them together, apply power, and wait for the music (or the CW). Best to do this at a club meeting, where everybody can share in the triumphs of individuals and club.

- **Document What You've Got** - As a minimum, the individual constructors should provide the greasy schematic with parts values, and part numbers for unique parts. Put it in a common notebook to accompany the equipment. Somebody in the club simply must volunteer to be a photographer (ya gotta have pix!). If the club or a club member has a web page, try to post the documentation so the whole world can admire your work.

The All-Important Block Diagram

The Block Diagram is probably the easiest way to "put-down-on-paper" what you specifically want to accomplish. I suggest one block for each assignable sub-project (module). I also highly recommend a set of written input/output specifications, so people constructing the individual modules un-

derstand exactly what's coming at them, and what they're expected to provide. This is all really pretty simple, but worth the time and effort in the long run. At the bottom of this page, I'll provide an example, based on a QRP CW Transceiver, which you may review as a model for your own project, or adopt outright.

When creating the block diagram, keep the following in mind:

- Overall Functional Goals - Club members should agree on what they want the final hardware to do. Always keep these goals in mind. HINT: Start simple, but keep future expandability and re-usability in mind.

- Modularity - Break your transceiver into small, workable sub-projects. Think of what can be constructed in a weekend. Consider the ability to replace any stage in the future, should someone want to experiment or improve the design.

- Form Factor - Agree on the packaging methods. We suggest the · Altoids-boxes (or similar) for enclosing each sub-project. This forces the projects to be small, simple, workable units, and the metal box is dirt cheap, widely available, and provides excellent shielding.

- Interconnections - Agree on how stages will interconnect, and define that for each stage in the design (each block or module). We suggest RG-174 and RCA phono jacks/plugs wherever possible, because they are cheap and readily available. For RF power stages, we recommend BNC hardware, for equipment compatibility and good shielding. And for power, we recommend 5.5 x 2.5 mm barrel-type power connectors, for their availability and universality.

- I/O - Define all inputs and outputs for each module. By specifying input and output impedances and expected output levels, you assure that any element can be replaced in the future by a new design. Don't forget control signals... these can really mess you up if they are not defined. But keep in mind that you want to give the individual designer/constructor maximum freedom, and don't narrow things down so much that their creativity is stifled.

- Power - Agree on the power requirements. We suggest 9-15 V, so that any module may be operated on a 9V battery (for testing), and a 12V battery that's charging.

- KISS - (Keep It Simple, Silly) The "Club Sandwich" is intended to be a fun, team project, not an engineering breakthrough. Keeping it simple is part of the challenge (and reward).

- KIRC - (Keep It Really Cheap) By keeping the sub-projects small and using inexpensive components, you'll increase participation among members and encourage sharing designs with the general ham population.

- TEAM - OK, we all know what this means, right? Find a way to include every club member that wants to participate. Some may not want to build a module, some may only want to do paper design; some will help with documentation or provide parts, or mentor another.

- TIME - Keep the timetable loose and flexible; with busy personal schedules, and given the volunteer nature of the membership, along with the different skill levels involved, this project can take several months. If an enthusiastic and skilled member has more time, and gets done early, create new modules, different versions of the same module, or assign them to mentor.

Once the block diagram is drawn, make a list or table of the requirements for each block element. This will form the module specification. Include:

- The name of the sub-project
- Its function (i.e., Mixer, Receiver Preamp, IF amplifier with AGC, etc)
- Name all I/O ("RF in", "AF Out", "Key In", etc)
- For each I/O port, define frequencies, impedances, and expected signal levels
- For each I/O port, define what connectors are to be used
- Any required operator controls ("Tune", "Gain", "On/Off")
- Any special or internal specifications (though we like to leave this to the individual)

Block Diagram of Club Sandwich

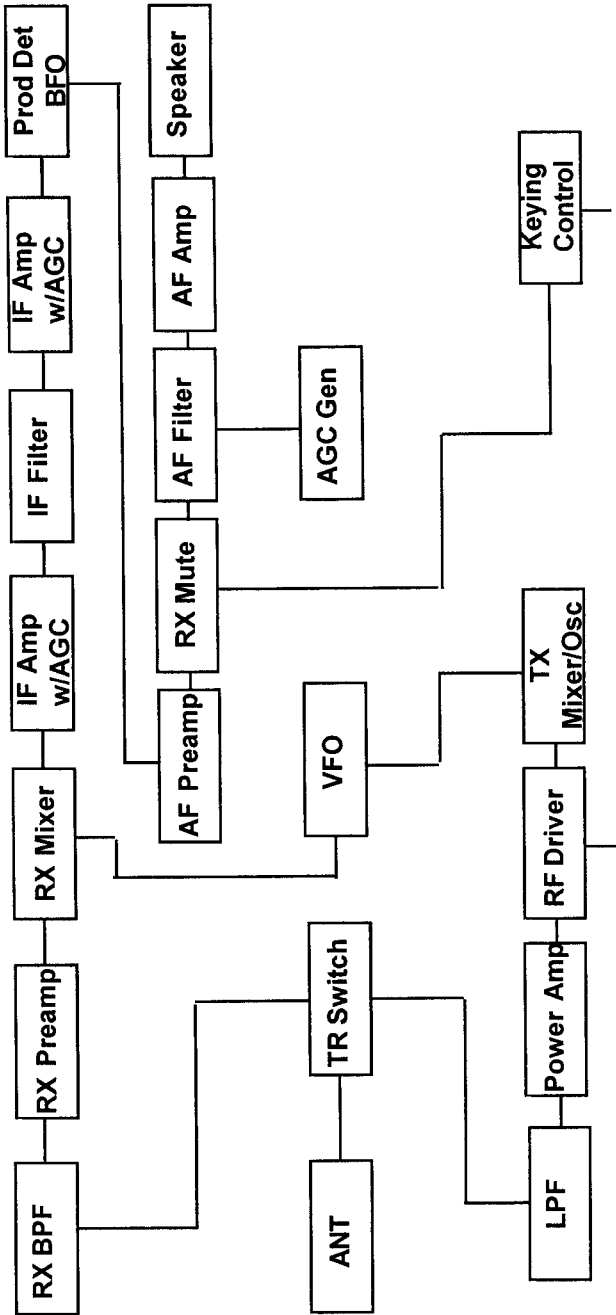

Expected power supply range

From Block Diagram to Individual Designs

When creating the block diagram and module specs, stay flexible, but keep the “big picture” in mind. Individuals may want to alter their module’s specifications, and in some cases this will certainly be warranted. But in a project like this, changing specifications can have a ripple effect. For example, let’s say the person building the keying circuit decides to use 5 Volt logic, when 12 V was specified. Now, every module that used keying (and there are many) will need to be redesigned. It is the job of the team coordinator to “see the big picture” and steer individuals back to a reasonable solution.

This is not to say that individuals constructing sub-projects do not have latitude. In fact, they have a lot. Circuitry, parts selection, and construction methodology are all at the discretion of the individual or sub-project team. Want to do something innovative? Do it! Use proven methods! Go ahead! Use surplus parts? Why not? Use an exotic sample? Who’s to stop you? Machine your own capacitors? Grow your own silicon? More power to you. The point is, there’s a lot of room for individual expression here, while staying within the agreed guidelines and specifications.

Every participating individual should receive a copy of the block diagram. This helps them keep the “big picture” in mind, a valuable reminder when you’re designing and building a part of the whole. As the sub-projects are completed, give each individual a chance to “show-and-tell”, and put their schematic and parts notes into the comprehensive project notebook. Make sure their name and call are on the paperwork. Hand-drawn schematics and hand-written notes are fine.

This is guaranteed to be a learning experience for every club member. Members who have no building experience will have to crack a book, and ask questions. Experienced builders will have to work within the bounds of specifications,

expand their horizons, and help others. Everyone will see how their little piece support the whole, whether it be a piece of hardware, some documentation, the acquisition of parts, or some individual expertise.

An Example, and a Proposal for the First Club Sandwich

As a starting point, we offer the attached block diagram of a QRP CW Transceiver. Frequencies have not been specified; you should select a band, and decide on an IF frequency. We suggest, for starters, 40, 30, or 20 meters. Use cheap microprocessor crystals for the IF filter and mixer injection, all the same frequency. If you use both transmit and receive mixers (as shown in the example), you'll generate sidetone directly. If you want to keep it really simple at first, ditch the IF and build a direct-conversion receiver, and/or use a VXO for your transmit source. We'll go all the way with our example, showing a single band, 3-5 Watt CW transceiver, with good flexibility and expansion capability to SSB or digital modes. We'll show a conventional VFO, but there's no reason a DDS or PLL couldn't be substituted (thus getting the digital and software types involved). Or, build all 3 individually, and try them all out (that's the power of modularity). See the Block Diagram on the next page.

Club Sandwich Block Diagram Specifications

Module: Receiver Band Pass Filter

Function:

Provides filtering at input of receiver to reduce image and reduce unwanted out-of-band signals

Input/Output:

- RF IN: 50 ohms, RCA Jack
- RF OUT: 50 ohms, RCA Jack

Key Specs or Limitations:

Frequency range: To be determined

Misc Notes:

Typically, this is a double-tuned circuit, or a high-Q preselector with a “peaking” control
Adding a switchable attenuator might be useful here also

Module: Receiver Preamp

Function:

Improve noise figure and sensitivity, and provide 10-12 dB of pre-mixer gain

Input/Output:

- POWER: 9-15 VDC, 5.5 x 2.5mm power jack
- RF IN: 50 ohms, RCA Jack
- RF OUT: 50 ohms, RCA Jack

Operator Controls:

- IN/OUT Switch (Optional: to bypass preamp when gain not required)

Key Specs or Limitations:

Gain: 10 - 13 db (fixed)

Noise Figure: < 3 dB

Misc Notes:

May be narrow band (i.e., single band) or broadband 3-30 MHz (for broadband, please equalize gain)

Module: Receiver Mixer

Function:

Convert pre-filtered RF to IF (or to audio if direct-conversion receiver)

Input/Output:

- POWER: 9-15 VDC, 5.5 x 2.5mm power jack
- RF IN: 50 ohms, RCA Jack
- VFO IN: 200 ohms, RCA Jack
- IF OUT: 200 ohms, RCA Jack

Operator Controls:

- No operator controls anticipated

Key Specs or Limitations:

- Frequencies In/Out: To be determined

- Gain: 10-15 dB (fixed, RF to IF Voltage Gain)
- Noise Figure: < 6 db
- Tank Circuits: min 1 tank circuit in output stage (or LPF in D-C rcvr)
- VFO Input: expect 0.25V pk-pk

Misc Notes:

If an active mixer is used (like the NE602/SE612), an output amplifier will probably not be required; if a passive (diode ring) mixer is used, a VFO input amplifier and an IF/AF output amplifier will be required. Amplifiers, if used, should have tank circuits to minimize unwanted responses

Module: Post-Mixer IF Amplifier

Function:

Reduce Noise and provide gain/AGC prior to IF filtering

Input/Output:

- POWER: 9-15 VDC, 5.5 x 2.5mm power jack
- IF IN: 200 ohms, RCA Jack
- IF OUT: 200 ohms, RCA Jack
- AGC IN: $Z_{in}=1K$; 0 to 2.5V (0V = Max gain, 2.5V = 20dB down)

Operator Controls:

- Manual Gain (Optional, in case AGC not available)

Key Specs or Limitations:

- Frequency: To be determined (Audio if D-C receiver)
- Gain: 6- 10 dB at max gain (i.e., at AGC= 0V)

Misc Notes:

Module: IF Filter

Function:

provide narrow-band filtering at IF Frequency (not required for direct-conversion receiver)

Input/Output:

- POWER: 9-15 VDC, 5.5 x 2.5mm power jack (if

required)

- IF IN: 200 ohms, RCA Jack
- IF OUT: 200 ohms, RCA Jack

Operator Controls:

- No operator controls anticipated

Key Specs or Limitations:

- Crystal Ladder Filter or equivalent
- Minimum 3 crystals (more preferred)
- Use crystals specified for 20 pf load capacitance

Misc Notes:

Module: Post-Filter IF Amplifier

Function:

Provide gain/AGC after IF filtering

Input/Output:

- POWER: 9-15 VDC, 5.5 x 2.5mm power jack
- IF IN: 200 ohms, RCA Jack
- IF OUT: 200 ohms, RCA Jack
- AGC IN: $Z_{in}=1K$; 0 to 2.5V (0V = Max gain, 2.5V = 20dB down), RCA Jack
- SAMP OUT(Optional): $Z_{out} < 200$ ohms, RCA Jack (provides sample of IF for external AGC generation, if used)

Operator Controls:

- Manual Gain (Optional, in case AGC not available)

Key Specs or Limitations:

- Frequency: To be determined (Audio if D-C receiver)
- Gain: 10- 12 dB at max gain (i.e., at AGC= 0V)

Misc Notes:

Module: Product Detector / BFO

Function:

Provide product detection for CW / SSB; includes BFO

Input/Output:

- POWER: 9-15 VDC, 5.5 x 2.5mm power jack
- IF IN: 200 ohms, RCA Jack
- AF OUT: $Z_o=200$ ohms max, RCA Jack

Operator Controls:

- BFO Frequency Adjust (may be a screwdriver trim)

Key Specs or Limitations:

- Frequency: To be determined
- IF-to-Audio Voltage Gain: 10- 15 db (fixed)
- Use crystals specified for 20 pf load capacitance

Misc Notes:

44414. This stage not used in direct-conversion receiver

44415. If an active mixer is used (like the NE602/ SE612), an output amplifier will probably not be required; if a passive (diode ring) mixer is used, an AF output amplifier will be required. An amplifier, if used, should have low-pass roll-off to minimize hiss and eliminate IF feedthrough to the output.

Module: AF Preamp

Function:

Provide gain for Direct Conversion Receiver (not needed for receiver with product detector)

Input/Output:

- POWER: 9-15 VDC, 5.5 x 2.5mm power jack
- AF IN: $Z_{in} \geq 2K$, RCA Jack
- AF OUT: $Z_{out} < 200$ ohms, RCA Jack

Operator Controls:

- Gain Control Optional (may be screwdriver trimmer)

Key Specs or Limitations:

Voltage Gain: 10-15 db (fixed)

Output: AC-coupled

Misc Notes:

This stage not required for receiver with product detector stage

Module: Receiver Mute and AF AGC Circuit

Function:

Provide for muting of receiver during keying; optionally provides AGC for receivers with IF AGC (and preferably for direct conversion receivers)

Input/Output:

- POWER: 9-15 VDC, 5.5 x 2.5mm power jack
- AF IN: $Z_{in} = 10K$, Z_{source} expect 200 ohms, RCA Jack
- AF OUT: $Z_{out} \leq 200$ ohms, $Z_{load} = 2K$, RCA Jack
- KEY IN: $Z_{in} \geq 10K$, driven by CMOS; RCA Jack
- AGC IN (Optional): $Z_{in} \geq 10K$, 0-2.5V, where 0V = max throughput, 2.5V = max attenuation

Operator Controls:

- No operator controls anticipated

Key Specs or Limitations:

- Voltage Gain: -3 to 0db (with AGC = 0V)
- Voltage Gain: -20 dB (i.e., minimum loss, more loss is preferable) (with AGC = 2.5V)
- Output AC coupled

Misc Notes:

Module: AF Filter

Function:

provide audio bandpass shaping or filtering, as appropriate for CW or SSB

Input/Output:

- POWER: 9-15 VDC, 5.5 x 2.5mm power jack
- AF IN: $Z_{in} = 2K$, RCA Jack
- AF OUT: $Z_{out} < 200$ ohms, RCA Jack
- SAMP OUT: $Z_{out} < 200$ ohms, RCA Jack (2nd buffered output for external AGC generator)

Operator Controls:

- CW/SSB switch
- others as required

Key Specs or Limitations:

- For SSB: LPF with $F_c=2.5\text{-}3\text{KHz}$ or BPF = 300-3000 Hz

For SSB, midband (1 KHz) gain = 0 dB (i.e., x1)

- For CW: BPF with $F_o = 750\text{-}800$ (fixed, or include that freq if filter is variable)

For CW, Bandwidth (3 dB) 400-500 Hz (fixed)

For CW, Gain at $F_o = 4\text{-}6$ db

- Output : AC- coupled

Misc Notes:**Module: AF Power Amplifier****Function:**

Monoraul Audio Amplifier, with two inputs, one for audio, one for sidetone, capable of driving 8-ohm headphones

Input/Output:

- POWER: 9-15 VDC, 5.5 x 2.5mm power jack
- AF IN #1: $Z_{in} \geq 5\text{K}$, RCA Jack
- AF IN #2 (Sidetone): $Z_{in} \geq 5\text{K}$, RCA Jack
- HEADPHONES: 1/8 " Stereo Jack
- SPKR (Optional): RCA Jack

Operator Controls:

- AF GAIN (pot)
- SIDETONE LEVEL SET (can be screwdriver trimmer)

Key Specs or Limitations:

- 0.5 mV, 1 KHz Sine at input gives full volume audio with AF GAIN control set midway

Misc Notes:**Module: AGC Generator****Function:**

Based on an IF or AGC sample provided, generate AGC Voltage to be utilized by AGC-controlled stages

Input/Output:

- POWER: 9-15 VDC, 5.5 x 2.5mm power jack
- SIG IN: $Z_{in} \geq 20K$, RCA Jack
- AGC OUT: $Z_{out} \leq 200$ ohms; RCA Jack

Operator Controls:

- Switch: ON/OFF/MANUAL

Key Specs or Limitations:

- Input signals of 3 V p-p cause maximum AGC output (i.e. 2.5V); no signal causes near 0 V output
- Full Wave Rectified Detection
- Using switch, AGC may be turned ON or OFF, or a Manual Gain pot may be placed in circuit, with output 0-2.5 V

Misc Notes:

Module: Transmit Mixer and Oscillator

Function:

converts VFO frequency to output RF frequency; includes crystal-controlled conversion oscillator

Input/Output:

- POWER: 9-15 VDC, 5.5 x 2.5mm power jack
- VFO IN: $Z_{in} = 200$ ohms, expect 250 mV p-p RCA Jack
- RF OUT: $Z_o = 200$ ohms, RCA Jack
- KEY IN: $Z_{in} \geq 10K$, RCA Jack (0V = key-down)

Operator Controls:

- No operator controls anticipated

Key Specs or Limitations:

- Gain (VFO to Output Voltage Gain): 10 - 15 db (fixed)
- XTAL controlled conversion Oscillator must be trimmable +/-1 KHz min
- Use crystals specified for 18-20 pf load capacitance
- Keying applies to either the VFO or XTAL oscillator,

disabling that oscillator during receive periods

- Key-down enables output
- Backwave < 2 mV p-p
- Minimum 1 tuned tank in output circuit

Misc Notes:

Module: Transmit Driver

Function:

Gain and Filter; provides drive to RF Power Amplifier

Input/Output:

- POWER: 9-15 VDC, 5.5 x 2.5mm power jack
- RF IN: $Z_{in} = 200$ ohms, expect 0.8 V p-p, RCA Jack
- RF OUT: $Z_{out} = 50$ ohms, BNC Jack
- KEY IN: $Z_{in} \geq 10K$, driven by CMOS, RCA Jack, 0 V = key-down (i.e., transmit)

Operator Controls:

- Drive Level (may be screwdriver trimmer)

Key Specs or Limitations:

- Frequency: To be determined
- All stages should be linear (i.e., class A or AB)
- Expect Input signal of 0.8 V p-p into 200 ohms
- Output Power (at $V_{supply} = 13VDC$): 350 mW (10.8 V p-p into 50 ohms)
- At least one stage should have a tuned tank circuit
- Output stage should withstand loads of 5-500 ohms without damage
- Backwave (during key-up) should be at least 25 db down (i.e., < 1 mW)

Misc Notes:

Pay attention to keying waveshape, as this will influence final transmitted signal

Module: RF Power Amplifier

Function:

provide 3-5 Watts RF output

Input/Output:

- POWER: 9-15 VDC, 5.5 x 2.5mm power jack
- RF IN: $Z_{in} = 50$ ohms, expect 10.8 V p-p, BNC Jack
- RF OUT: $Z_{out} = 50$ ohms, BNC Jack
- KEY IN: $Z_{in} \geq 10K$, driven by CMOS, RCA Jack 0 V = key-down (i.e., transmit)

Operator Controls:

- No operator controls anticipated

Key Specs or Limitations:

- Class AB preferred for future SSB use, Class C OK
- Gain 12-14 with .25-.35 W drive (typ)
- Broadband topology preferred, single band OK
- Push-Pull preferred for 2nd harmonic rejection, single ended OK
- Output stage should withstand loads of 5-500 ohms without damage
- Negligible backwave when un-keyed (< 1 mW)
- Heatsink may extend outside normal form factor

Misc Notes:

Module: Output Low Pass Filter

Function:

Provides harmonic rejection

Input/Output:

- RF IN: 50 ohms, BNC Jack
- RF OUT: 50 ohms, BNC Jack

Operator Controls:

- No operator controls anticipated

Key Specs or Limitations:

- 5-7 pole filter (7 preferred)
- capable of handling 25 watts (to accommodate mismatches without arcing)

Misc Notes:

Module: VFO

Function:

Provides injection for Receiver Mixer or Transmit Mixer, as appropriate; includes R.I.T. offset

Input/Output:

- POWER: 9-15 VDC, 5.5 x 2.5mm power jack
- OUT #1: $Z_o = 200$ ohms, RCA Jack
- OUT #2: $Z_o = 200$ ohms, RCA Jack
- KEY IN: $Z_{in} \geq 10K$, driven by CMOS, RCA Jack
(0V = key-down; i.e., transmit)

Operator Controls:

- Main Tuning

Key Specs or Limitations:

- Frequency: To be determined
- Two independently buffered outputs provide 0.25V p-p (0.30V p-p max) into 200 ohms
- Outputs AC Coupled
- Receiver (output 1) offset automatically engaged during receive
- R.I.T control +/- 2KHz min
- Oscillator and tuning stages powered by linear regulator
- For VFO, min 2-stage buffering; For VXO, min 1-stage buffering

Misc Notes:

Module: Keying Control Circuit

Function:

Provides transmit/receive control signals with sequenced delays, to be used by other circuits that need to be keyed

Input/Output:

- POWER: 9-15 VDC, 5.5 x 2.5mm power jack
- KEY IN: 1/8" Mono Jack

Max Input loading (to keyer): 10K (pull-up to Vsupply)

INput states: open = RX; Ground = TX

- KEY0: CMOS/equiv, RCA Jack; Low on key-down, High on key-up (raw keying)
- KEY1: CMOS/equiv, RCA Jack; Low 1 mSec after key-down, High on key-up (keys TX)
- KEY2: CMOS/equiv, RCA Jack; Low 0.5 mSec after key-down, High 0.5 mSec after key-up (keys VFO)
- KEY3: CMOS/equiv, RCA Jack; Low on key-down, High 1-50 mSec after key-up (RX muting)

Key Specs or Limitations:

Misc Notes:

Trimmer or programmable control of KEY3 delay, to accommodate unknown receiver recovery time

Module: Antenna T/R Switch

Function:

Provides switching for antenna circuit, between transmit and receive

Input/Output:

- POWER: 9-15 VDC, 5.5 x 2.5mm power jack (if power required)
- ANTENNA: 50 ohms (nom); BNC Jack
- RCVR OUT: 50 ohms (nom); RCA Jack
- XMIT IN: 50 ohms; BNC Jack
- TR CONTROL: Control from Keying Control Circuit, RCA Jack

Max Zin = 10K/0.01uF;

Input Signal States: Open or Vsupply for RX; Ground for TX

NOTE: If switching is RF-sensed, this input may not be needed

Key Specs or Limitations:

- Max TX power 10 Watts

Misc Notes:

Module: Sidetone Generator

Function:

generate keyed CW sidetone for injection into audio chain

Input/Output:

- POWER: 9-15 VDC, 5.5 x 2.5mm power jack
- KEY IN: $Z_{in} \geq 10K$, to be driven by CMOS (LO=key-down), RCA Jack
- AF OUT: 1 Volt pk-pk

Operator Controls:

- No operator controls anticipated

Key Specs or Limitations:

- Frequency: 750-800 Hz
- Output Amplitude 1 V p-p (nom)
- Output AC-coupled
- No output when un-keyed
- Sine or near-sine preferred

Misc Notes:

This stage not required in receiver that self-generates sidetone from transmit mixer

Interfacing external control software to the FT817

by Graham F Firth G3MFJ/W3MFJ

Some time ago, Bob Freeth (G4HFQ) produced an FT817 control program called FTBasic which he produced as shareware. This program installed on a PC and using a suitable interconnection cable, would remote control the FT817. (Incidentally the program will also control the FT847, FT100 and FRG100). I downloaded and installed this, but before I could use it, I needed a gizmo to convert the RS232 level signals (+12 to -12v) to the TTL signal (0 to +5v) needed by the ACC jack on the 817.

I looked around Internet (well, doesn't everybody?) to

find the circuit and I came up with one that lots of people seemed to be using. Maxim have produced an IC which will do just this, including generating the necessary +10 and -10 volt rails from the chip's main 5v supply. A 5v regulator is needed to obtain the required 5v rail from the FT817.

Although this looks complicated at first glance, the majority of the components are associated with the power supply section of the chip.

Components list:

1 off MAX232 16 pin DIL (with socket if required)

1 off LM7805 100mA 5v regulator

3 off 10uF 16v electrolytics

2 off 3.3k resistors

1 off 0.1uF capacitor

1 off 9 pin RS232 female socket

1 off 8 pin miniature DIN plug

The circuit can be built up on a piece of perfboard, ugly style on blank PCB or even Manhattan style. I chose ugly style & built it in the 9 pin RS232 plug, but I can only recommend this is you are happy working this way as the plug cover has only just enough room for the components.

I must issue a dire warning here - please do not short the wire that supplies the power to the gizmo from the FT817 (the bottom right hand pin looking into the 817). Whilst this has adequate power capability to run the interface, it will not stand being shorted to chassis at all. The output is protected by the tiniest 10 ohm resistor you could imagine - guess how I know? I had to use a powerful magnifying glass just to see it - and I have a copy of the service manual & knew where I was looking! Check and double check your construction before you plug it in!

The gizmo worked fine and I paid the registration fee for the software - I was so impressed. However, since then,

Simon Brown (HB9DRV), has produced a program that is freeware and is called FT827-Commander. It is a much more comprehensive program than FTBasic, I have given the URLs for both pieces of software at the end of this article.

In the next article, I will show how to build this circuit on perfboard and it will include the PSK31 interface as well.

FTBasic is available from:

<http://dspace.dial.pipex.com/town/avenue/aci07/polarplot/>

FT817-Commander is available from:

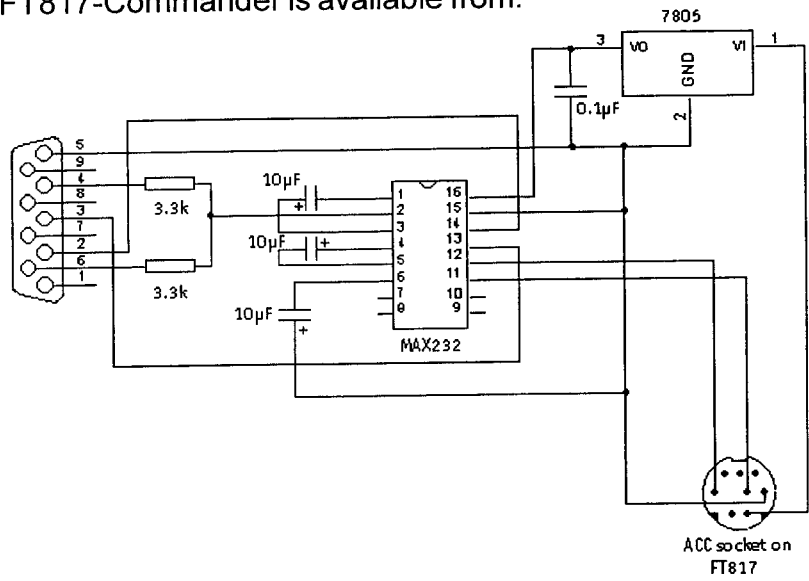

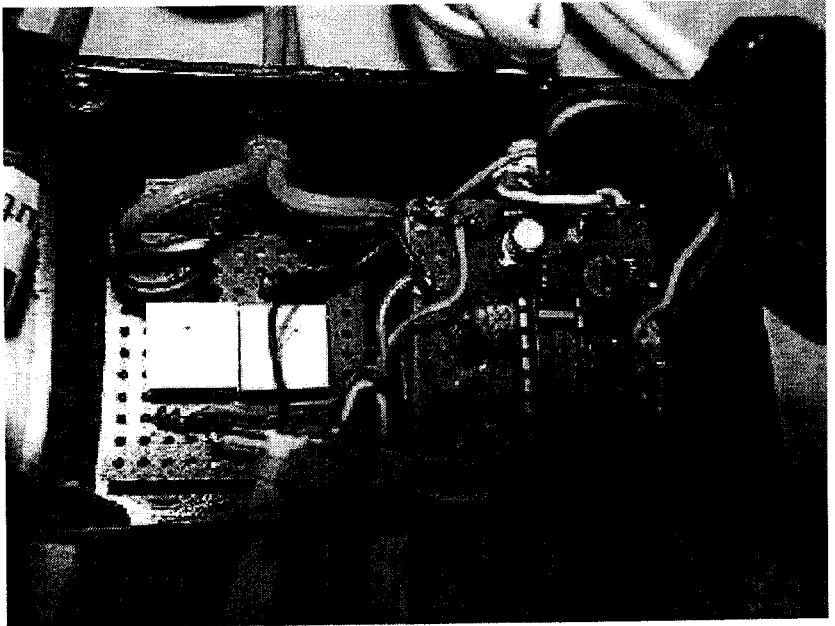
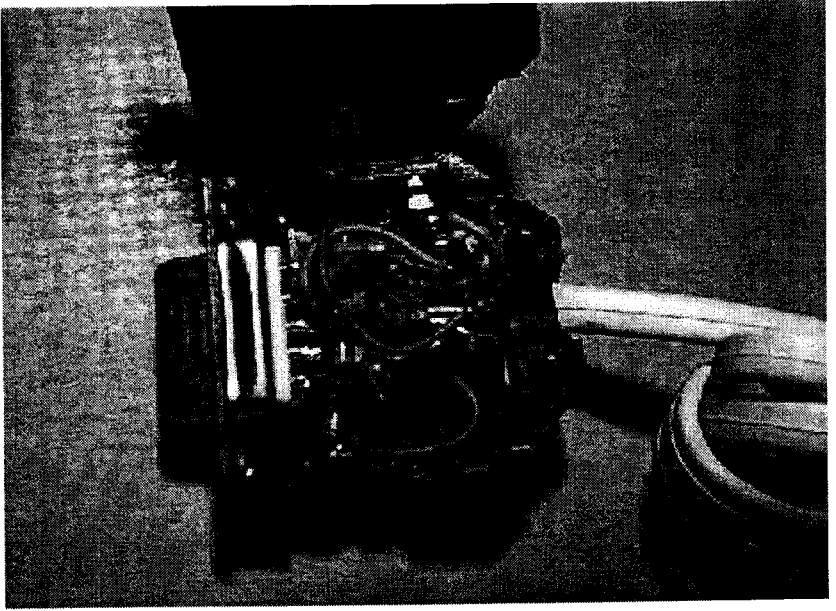

Building an Interface for the External Control Software to the FT817

Graham F Firth G3MFJ/W3MFJ

My last article in this publication showed how a program running on a PC could control the FT817 and enhance the operation of this wonderful little rig. The article before that, showed how to make a PSK31 interface, again to connect the FT817 to a PC.

This time, I am combining these two interfaces, so that the same PC can run PSK31 and provide an interface program at the same time. All the software I previously recom-

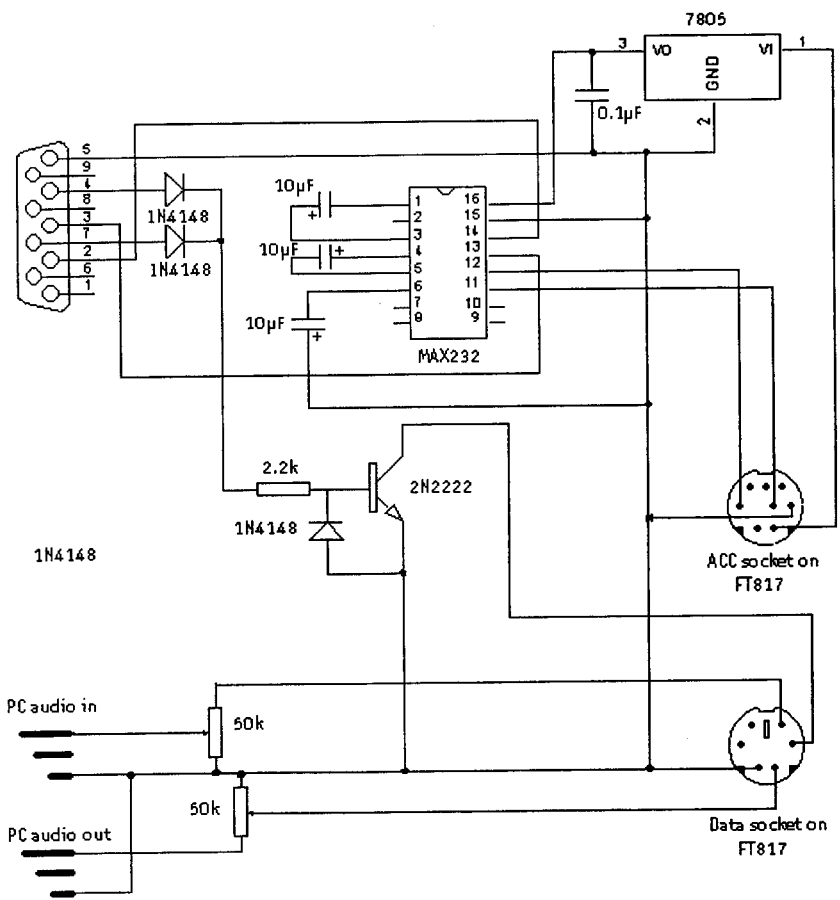

mended will still work ok, but as well as all these, Simon Brown HB9DRV has produced a combined program, still called FT817-Commander, but which incorporates PSK31 Deluxe. This is another variant on the PSK31 software theme.

If you refer to the earlier articles, you can see how this circuit has been obtained.

Again, it is built into a small plastic box and a photo of this is shown below.

Components list:

- 1 off MAX232 16 pin DIL (with socket if required)
- 1 off LM7805 100mA 5v regulator
- 3 off 10uF 16v electrolytics
- 2 off 3.3k resistors
- 1 off 2.2k resistor
- 3 off 1N4148 (or similar) diodes
- 1 off 0.1uF capacitor

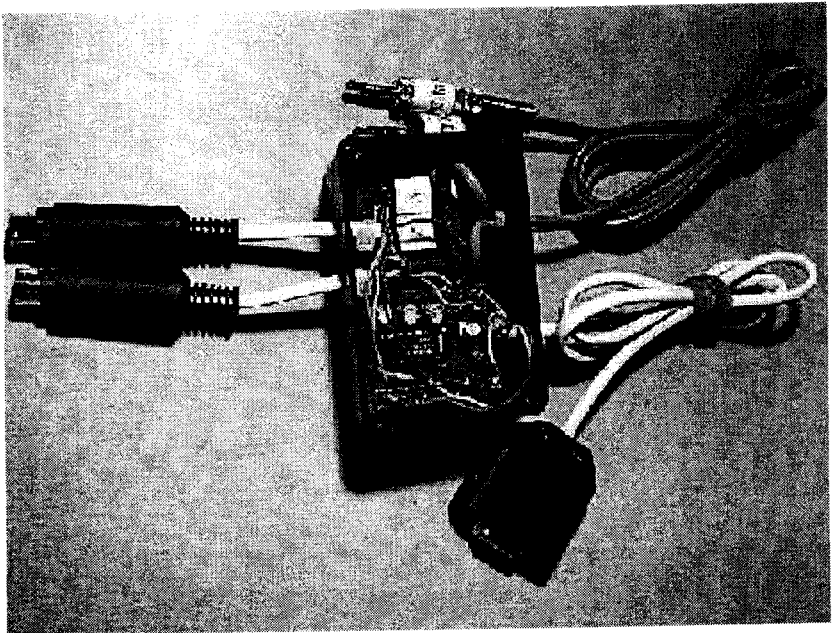

G3MFJ's Complete Interface for the 817

- 1 off 9 pin RS232 female socket
- 1 off 8 pin miniature DIN plug
- 1 off 6 pin miniature DIN plug

My construction this time uses two small pieces of perfboard, one for the electronics, and the other for the two pre-set level control pots.

I must issue a dire warning here again. Please be careful and do not short the wire that supplies the power to the gizmo from the FT817 (the bottom right hand pin looking into the 817). Whilst this has adequate power capability to run the interface, it will not stand being shorted to chassis at all. The output is protected by the tiniest 10 ohm resistor you could imagine - guess how I know? I had to use a powerful magnifying glass just to see it - and I have a copy of the service manual & knew where I was looking! Check and double check your construction before you plug it in!

That's it - I hope you get as much fun out of this as I have.

FT817-Commander is available from:

[http://www.kns.ch/sysgem/hb9drv/
FT817%20Commander.htm](http://www.kns.ch/sysgem/hb9drv/FT817%20Commander.htm)

Arkiecon 2002 Diary

by Tony Fishpool, G4WIF

Last year I enjoyed Arkiecon immensely, but because this year I am attending Fort Tuthill, I really didn't intend to be anywhere near Fort Smith in April - well that was the plan anyway! Eventually I caved in - I just had to get another fix of Arkansas hospitality, and if you've never been, these folk define that word.

Graham G3MFJ had already similarly succumbed to temptation and he had arranged his flights many weeks previously. When I booked late it meant we had to travel separately and so met at Tulsa International late on Wednesday night. We stayed locally and drove to Fort Smith the following day.

Graham's GPS led us directly to Jay's house and soon after the three of us were collecting Vern Wright from the local airport. Vern is one of the most generous guys I know - he donates many of his superb antennas to events such as Arkiecon so that they can be presented as door prizes. Back at Jay's house again we just had time to get reacquainted when Jim (Dr. Megacycle) Duffy called into the local repeater for directions and soon the five of us were catching up on a year's worth of gossip while we sampled the micro brewery products that Jim bought.

Actually, this activity really sums up a large part of what went on over the next few days - I had one enjoyable rag chew after another with friends made from previous years and many new ones. The next old friend to arrive was "gentleman golfer" Dave Yarnes and later that evening we all enjoyed a massive steak each - barbecued by Jay's lovely new bride Kathy. By the time Doug Hendricks rolled in we were sitting back in Kathy's living room wondering if we would ever move again - Kathy cooks really excellent steaks!

The Fort Smith QRP group had negotiated us a fabulous rate at the superb Guesthouse Hotel and the folk at the Guesthouse were great. They allowed us to use the break-

fast room to gather in during the late hours where it was usually "standing room only" for more QRP gossip.

Friday was a day with more and more people arriving. Ed Manuel and the Texas boys rolled in and soon the hotel was buzzing. Back at Bromley Mansions, Jay, Doug and myself beavered away for an hour or so putting together several dozen Tuna-Tin kits. All were sold the following day and such is their popularity we could have sold many more.

Later in the evening, the Ribeye Restaurant had reserved almost all of their tables for us, and it was great to be able to renew a friendship with Glen & Gail Reid from Austin as we caught up on events since we were last together a couple of years previously. Those Texas folk also know a thing or two about hospitality!

Last year I took a lot of stick from Doug Hendricks because I didn't try the Turkey Fries, so summoning up the old Dunkirk spirit, I ordered a portion. Having considered the matter carefully I have decided they were better off being a vital part of the Turkey - Doug, they really suck! There being no such thing as a quiet group of QRPers, I felt really sorry for the waitresses as they were battling to hear the orders, but they managed magnificently.

The following morning many people rose at an inhuman hour to eat out at a local diner. I'm not well known for my ability to get up early (or manage large breakfasts) so I ate in the hotel and there had the opportunity to make the acquaintance of Rex KC5UVN and we spent a delightful hour putting the world to rights. Then it was time to get to the Columbus Halls where George Dobbs opened the lectures after a suitable introduction by Master of Ceremonies Doug KI6DS. George spoke first about keeping QRP simple and introduced us to a new word - "pelf" - roughly defined as "the things we don't really need but feel we ought to acquire". In the afternoon George discussed many of his favourite construction techniques.

Roy Lewallen gave us two fine talks. The first was about

antennas and how some manufacturers claim what they do for their products and still manage to get past consumer law by not actually lying (my words - Roy rather was more polite!). The second talk later in the day was about antenna modelling. Roy is gifted with a way of explaining complicated things so they seem easy. I learned a lot from both talks.

Sandwiched between these renowned "Hall of Famers" was Graham G3MFJ who introduced us to a few new things to do with an FT817. Graham explained how simple and freely available software can both remotely control this marvellous little radio and allow PSK81 operation.

Out in the other hall busy exhibitors were conducting brisk business. Dennis Foster had a display of his "Te Ne Keys" and hopefully sold bucket loads because these are really superb morse keys. It was certainly a "lump in the throat" moment when Dennis presented me with a lovely key personalised with my callsign. Dennis is another vendor whose generosity "oils" QRP events like this.

Later in the evening we enjoyed a free barbecue - courtesy of Fort Smith QRP. The food was great and I went up for seconds - I have never had beans that tasted that good!

Once again we retired to the Guesthouse and migrated first to the breakfast room and then up to visit with Dave W7AQK where we played with an FT817 connected up to one of Vern's MP2 antennas outside the window. These antennas really work well and the bands were alive that night as we supped the odd there was some nice Chardonnay circulating too.

Sadly, it all ended too soon as Dave had to get up really early to make his flight at Tulsa, so saying goodbye we moved onto George Dobbs room where there was more beer and other fine folk like Roy W7EL to gas with until the wee hours.

On Sunday again the early risers had gone to IHOP for breakfast but after a more leisurely breakfast I caught a lift with Mike WB5YJX (the new editor of QQ) and Henry whose callsign I regrettably forgot to note. We didn't have the ben-

efit of Graham's GPS, so travelled via the "scenic way" but we arrived after a very pleasant chat in the car. IHOP was fairly heaving with QRPers but eventually we all rather sadly said our goodbyes until the next time.

Jay and the Fort Smith folk put on a fabulous convention for us - with a lot of people quietly working in the wings. I would like to thank Kathy, Kelsey and Win and all the others I have neglected to mention. This is a world class event - you will be sorry if you miss it next year!

QRP Operating

By Richard Fisher, KI6SN

1940 Wetherly Way

Riverside, CA 92506

KI6SN@yahoo.com

Feedback on "Your QRP Accent"

Apparently, last quarter's essay "***Your QRP Accent, And What to Do About It***" resonated with a lot of "QRPP" readers.

This low power knock-off of Keith S. Williams, W6DTY's, classic "*Your Novice Accent, And What to Do About It*" focused on some of the QRP operating practices observed at KI6SN during about 40 years as a low power enthusiast.

Keith's original article appeared in the November 1956 edition of QST magazine, giving Novice newcomers tips on avoiding the pitfalls and bad habits many newly licensed operators of the time were falling into.

Although written in a different millennium, last quarter's "Your QRP Accent" takes a different tack from 'DTY's treatise, focusing on some of the brass pounding traits I've observed around the popular low power watering holes.

An e-mail from **Paul Brenner, W6RLF**, of Ross, CA, caught the essence of what many of you had to say: "Really enjoyed your article about the 'QRP Accent.'

"A lot of good tips. It caused me to go back and read the original 'Novice Accent' article also.

“On general operating practices, one I really have trouble with: Operators who run their (CW) characters together.

“Had a QSO - more or less - recently with a guy whose basic speed wasn’t beyond my ability; but as I haven’t made the transition to right-brained code copying, I need an instant to ‘translate’ the character.

“When someone runs the characters together, I don’t have the chance. I’m not arguing for Farnsworth spacing - though it’s nice. But a LITTLE spacing ain’t bad!”

As Paul and others so astutely pointed out, often times a station’s power output has little to do with whether or not QSOs are being made.

As a QRPer, if you’re finding it challenging to make contacts on CW, the first place to check is at the end of your arm.

In the big scheme of things, if your letter formation and CW spacing is so poor as to be unintelligible, all the power and high gain antennas in the world aren’t going to do you any good.

If you’re unsure about the quality of your CW, ask for a candid on-air assessment from a fellow QRPer or other operator you trust.

When you’re satisfied your fist isn’t the issue, then it’s time to look at antenna and feedline efficiencies, your transceiver or transmitter, or other elements of your station set-up.

But start with your fist. In many ways, it’s easier to fix than sky wires or blown final transistors.

The bottom line is: If you’ve got a QRP accent and you want to do something about it, the power to change is fully in your hands - or fist, as the case may be.

A little power. A little patience. A lot of success

Ken Hoglund, KG4FGC, of Winston-Salem, NC, concedes that “OK, playing (one night recently) on 20 meters was not very good, but I did hear some DX ops.

“Of course, I heard the usual kilowatt pileups and tossed my small signal against them with no success. Actually I

overheard one guy complain he couldn't work U4MW because he was 'only' at 1,200 watts.

"Then came across a call I had tried to work earlier in the evening: TMOX EU032.

"I caught him asking for 'the QRP station.'

"After two tries he had it. Then 'was there another QRP station?'

"Again, two tries and he had another. Then much to my amazement, 'Any other QRP stations on frequency?'

"You bet there was - one try and we had a QSO. And that's with 3 watts out on my White Mountain 20 into the attic dipole, SSB no less.

"Nice ears, and even nicer protocol in fighting the pack.

"So the bands may be rough, but there are gentlemen and gentieladies out there, even among the QRO crowd.

"It was my only QSO of the night, but well worth it. Get on the air and fire some RF out - you never know who may be on the receiving end."

QRP success in the WPX

Todd Enders, AG0T, writes from Minot, ND, that in the recent WPX contest he "spent a total of 16.5 hours operating time, which netted 135 QSOs worth 220 QSO points and 105 prefixes, for a total of 23,100 points.

"A total of 31 DXCC countries worked, including the USA. I had 85 U.S. and 50 DX QSOs. Worked 10, 15, and 20 meters. Only luck on 10 was 6Y2A and KH6ND - the only two signals heard on the band at the time (Sunday afternoon). Both 15 and 20 were red hot Friday night. DX was everywhere, and anything I heard was usually quite obliging. I worked 9H0A in Malta.

"6Y2A on 15 meters was a one-shot bag, not even 3 hours into the contest. Propagation Saturday (was poor). Seemed the bands were open, but long enough that there wasn't much stateside heard, and DX coverage was spotty at best.

"Would work, say, a DL after a few tries, find another one,

louder than the first, and couldn't hit him for beans, even when he was calling CQ with no takers. Then there were the ones I could hear OK, but were also seemingly deaf to my signal. Real frustrating going, with the QSO rate average over 5 hours a paltry 6.8 / hour.

"Burned me out big-time and I crashed early rather than going back for another round. After mowing the lawn Sunday, I felt like getting back into it again, so I fired up the rig and sat down to somewhat better conditions. At least I found some stateside business this go round, which lifted my spirits, and even managed to snag a few more DX stations, though coverage continued to be real spotty.

"In hindsight, I wish I'd have found some time to work 40 meters. I was planning to do so Saturday, but my body had other ideas. I did drop down to 80 meters for a bit Friday night late, but my local noise level was about S9, and though I called a couple guys I could hear, they couldn't hear me.

"The setup was an FT-817 into a Johnson Matchbox, which fed a Butternut HF-2V 80/40m vertical.

"Being 3/4 wave, more or less, on 15 meters, that's where I spent most of my time, though it also plays quite well on 10 and 20 meters. Have now worked DX with this setup on every band between 40 and 10 meters with the exception of 12 meters.

"It DOES have its limits though, and I'd have likely had much better results on Saturday if I'd had a nice beam way up there.

"Someday when I get out of this apartment . . . Anyway, it was fun! Wish I'd had the chance to do more operating, but for the time I put in, I'm not displeased with the results."

QRPacificon 2002

by Doug Hendricks, KI6DS

I am really excited to announce the speakers for QRPacificon to be held October 19, 20 and 21 at the Sheraton Hotel in Concord, CA. We have a wonderful lineup of speakers, including Paul Harden, Jim Duffy, Dave Benson and the designers of the new NorCal transceiver kit on 30 meters, Dan Tayloe and Dave Fifield. We have a full slate of activities planned and hope that you can attend.

Friday: 6 - 7:30 No Host QRP Dinner @ Fuddruckers

7:30 - 12:00 NorCal Qrp Hospitality Room open featuring the RockMite Nite Building and Operating Contest

Saturday: 8 - 1:00 QRP Forum Speakers:

Dave Benson, Dave Fifield and Dan Tayloe, Paul Harden, Jim Duffy

1 - 5:00 Visit Vendors and Socialize

5:30 - 7:30 Dinner on your own. This is a great time to get a small group of your friends together and go out for a nice meal.

7:30 - 12:00 NorCal QRP Hospitality Room open Featuring: NorCal VXO Contest Judging and NorCal Building Contest Judging. Presentation of NorCal Distinguished Service Plaques to 3 Great NorCal QRPers, QRP Vendors, QRP Swap

VXO Building Contest Rules

We have decided, at the suggestion of Dan Tayloe, to have VXO Building Contest. This contest will be held on Saturday night, October 20th, at the NorCal QRP Hospitality room at the Sheraton Hotel in Concord, CA. The purpose is to see who can get the greatest frequency swing out of a VXO for 40 meters and 20 Meters. Here are the rules:

1. The entry must be a VXO, NOT a VFO, and it will be tested for Frequency Swing and Stability.
2. The entry must use the following parts: 1SV149 Varicap

diode, 78L08 voltage regulator, 2.1 mm power jack and 1 or more 7.040 NorCal Crystals for 40 meters and 1 or more 14.060 crystals for 20 meters.

3. Each VXO will have a 2.1 mm power jack for power.

4. We will test each VXO by plugging it in to a 12V power supply provided by us.

5. Each VXO must use a SIP socket for 1 crystal. (If you parallel more than 1 crystal, you only have to socket 1 crystal.) All entries will use the same Official NorCal Great VXO Contest Crystal (that is stored in a Mayonaise jar in my Radio Room under lock and key until the contest) during testing.

6. Only NorCal 7.040 crystals may be used in the 40 meter VXO. (No Mixing Schemes)

7. Only NorCal 14.060 crystals may be used in the 20 meter VXO. (No Mixing Schemes)

8. There is a parts kit available from NorCal. It contains the following:

1 x 7.040 Crystal

1 x 14.060 Crystal

2 x 1SV149 Diode

2 x 78L08 Voltage Regulators

2 x 2.1 mm power jack

2 x SIP .!" Header

To order the kit send \$10 to Doug Hendricks. Make check or money order out to Doug Hendricks, not Norcal. Also, send \$3 for each additional crystal ordered. Be sure to specify frequency.

Send your orders to:

Doug Hendricks

862 Frank Ave.

Dos Palos, CA 93620

9. All entries must have a schematic accompanying it.

10. We will have an overall division, (add the 2 swings together of the 20 and 40 meter VXO), and a 20 meter and a 40 meter division.

11. If you wish to enter the contest and will not be attending, it is up to you to make arrangements to have your circuit entered. Ask on the list, I am sure that plenty of guys will step forward and offer to receive your entry and make sure it gets to the contest and back to you.

12. No variable caps allowed.

13. VXO circuits are to be built separately, i.e. you will build two circuits, one for 40 meters and one for 20 meters.

Rock Mite Nite at QRPacificon

We will have a special operating and building contest on Friday night at Pacificon this year. Teams will build and operate Rock Mites on Friday night. More details to follow, but basically teams will be formed to build a Rock Mite in a predrilled case (made from PC Board instead of Altoids tins) that they will also have to build.

When they get the rig built and working in the case, they will then have to copy a code word from a station operating in the room, and send the code word back to the station. There will be 4 members per team.

Teams will also have to supply their own antenna, and it has a restriction of 6', but can be pre built and brought to the event.

10 kits will be supplied by NorCal and Dave Benson, so we will have 10 teams in the event. Should be fun.

QRPacificon Building Contest

We will have our annual building contest again this year. Judges will determine the classes when they see the entries, and remember that it must have been built since last Pacificon and not entered in any other building contest.

The 'Rock-Mite'
A simple CW transceiver for 40 meters!
by Dave Benson, K1SWL

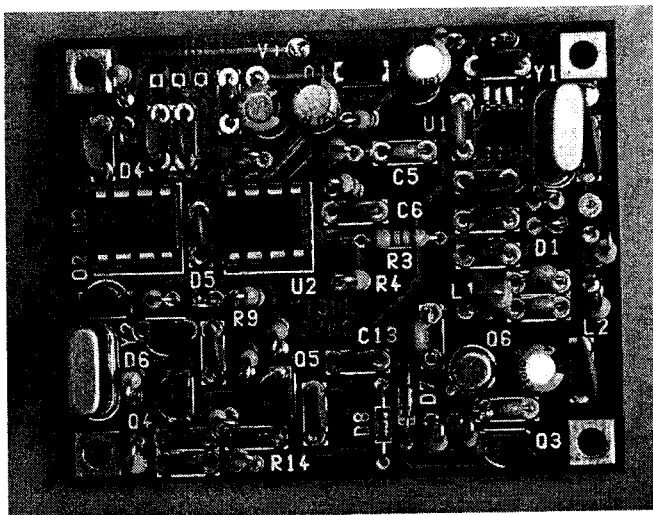

The 'Rock-Mite' design grew out of my desire to offer a 'one-evening' CW transceiver kit which would be both affordable and easy to construct. It first appeared at 'Lobstercon' - a QRP gathering on the Maine coast - in early July, 2002, where it was provided to all attendees courtesy of Small Wonder Labs and the NorCal QRP club.

The Rock-Mite is a crystal-controlled direct-conversion transceiver operating on 7040 KHz, the North American 'watering-hole' for QRP activity. It has an 8-pin PIC microcontroller on-board which controls a T-R offset on key-down. A brief tap of a pushbutton control switch reverses the offset to yield a second operating frequency. Pushing and holding on the pushbutton activates the speed adjustment routine for the built-in Iambic keyer. If you'd rather use an external keyer or straight key, there's a 'drop-through' mode which allows use of an external keying source.

You'll note in the image above that the Rock-Mite uses two crystals. The first is used in the local oscillator for trans-

mitter and receiver. The second is used as a receiver front-end filter. This crystal significantly reduces the 7100-7150 khz SWBC energy present at the receiver mixer; as a result, unwanted SWBC reception is dramatically reduced.

The Rock-mite uses one surface-mount part with fairly large spacing. There are no toroids to wind, so assembly should be a snap! The Rock-Mite uses subminiature epoxy-encapsulated RF chokes instead of toroids- maximum harmonic content is -34 dBc.

SPECIFICATIONS:-

- Double-sided PCB 2.0" x 2.5", plated-thru-holes, solder masked & silkscreened for easy assembly
- 0.5W power output at 12V supply.
- Supply voltage range 8-15V
- Tuning: fix-tuned, two frequencies ~7039/7040 Khz
- automatic T/R offset, reversible
- Built-in Iambic keyer, 5-40 WPM
- Built in sidetone, 700 Hz
- Includes assembly instructions and operating tips
- All on-board parts supplied in kit (as pictured above)

AVAILABILITY:

The Rock-Mite is shipping now! Allow 2 weeks for delivery. *QRPproject (Berlin) will offer the Rock-mite with 7.030 Crystals! Click on our main page 'Deutsch' link for further information.*

PRICE:

\$25 (US/Can) includes shipping*

\$28 (all others) includes airmail shipping*

** these include the 7.040 Mhz crystals. See 'QRPproject' for the European version. Other frequencies are not currently available.*

Please Note: There's no enclosure kit available for the Rock-Mite. It's 'Altoids-compatible', however, so a source of enclosures is probably as close as your nearest market or pharmacy!

To order send \$25 US & Canada, \$28 all others in US

Currency, Check or Money Order to:

Dave Benson, K1SWL
Small Wonder Labs
32 Mountain Road
Colchester, CT 06415

e-mail dave@smallwonderlabs.com

note: shipment is by Priority Mail unless you make other arrangements with me- pricing is available on request.

QRPP Subscriptions

QRPP is printed 4 times per year with Spring, Summer, Fall and Winter issues. The cost of subscriptions is as follows:

US and Canadian addresses: \$15 per year, issues sent first class mail. All DX subscriptions are \$20 per year, issues sent via air mail.

To subscribe send your check or money order made out to Jim Cates, NOT NorCal to:

Jim Cates
3241 Eastwood Rd.
Sacramento, CA 95821

US Funds only. Subscriptions will start with the first available issue and will not be taken for more than 2 years. Membership in NorCal is free. The subscription fee is only for the journal QRPP. Note that all articles in QRPP are copyrighted and may not be reprinted in any form without permission of the author. Permission is granted for non-profit club publications of a non-commercial nature to reprint articles as long as the author and QRPP are given proper credit. Journals that accept paid advertising must get prior permission from K16DS before reprinting any article or part of an article. The articles have not been tested and no guarantee of success is implied. If you build circuits from QRPP, you should use safe practices and know that you assume all risks.

**QRPP, Journal of the NorCal QRP Club
862 Frank Ave.
Dos Palos, CA 93620**

**First Class Mail
U.S. Postage
Paid
Mailed from Zip Code
93620
Permit #72**

First Class Mail

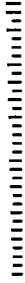

ie.

Volume X No. 2

Summer 2002

QRPP

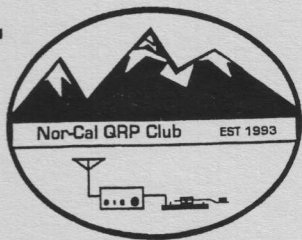

Summer 2002

Journal of the Northern California QRP Club

Table of Contents

Deluxe Direct Conversion Transceiver (Super Sprint Rig)

by Steve Weber, KD1JV, page 3

SMK-1 on 20 Meters

By Wayne McFee, NB6M, page 14

Introduction to the Electroluminescent Receiver

By David White, WN5Y, page 28

QRP To The Field 2002: Water World Deja Vú

by Jan Medley, N0QT, NorCal Contest Manager, page 34

W6QIF Oscillator

by Jim Pepper, W6QIF, page 42

The QRP Improv Antenna

by Joe Everhart, N2CX, page 54

From the Editor

by Doug Hendricks, KI6DS

I hope that you enjoy this issue, as it has several great articles with some meat to them. This issue is late again, but I am getting caught up with things. My job has really gotten intense, as we are being held accountable much more in education these days, and that is a good thing, but it does entail many changes and with change comes work. We have some exciting new kits coming down the line, as we will be kitting the NorCal MiniBoots designed by Wayne McFee, which is a 5 Watt amp that works on 20 - 40 meters. Also, Dan Tayloe and Dave Fifield are working furiously on the NorCal 30 kit, for which we shall be accepting orders soon. Check the NorCal page for details on when to order this kit.

I also would like to announce that I have accepted a long standing invitation from my very good friend George Heron to be a speaker at Atlanticon in March. I hope to meet many of the east coast QRPers there. I will also try and get Jim Cates to attend. 72, Doug

Deluxe Direct Conversion Transceiver (Super Sprint Rig)

by Steve Weber, KD1JV

This direct conversion receiver was inspired by Steve Kavanagh, VE3SMA's "Spartan Sprint Special" where he made extensive use of CMOS logic parts to build a small, light weight rig. His circuit was web published by the ARS Sojourner, in I believe, the June issue. You can see his original circuit by going to <http://www.natworld.com/ars> and ruttting around.

VE3SMA's receiver featured a 74HC4053 analog multiplexer as a mixer. I have made a few changes to improve the circuit he shows, by making the output balanced and adding a RF preamp for isolation. I also added a heterodyned VFO circuit, which is built around a 74HC86 XOR gate, because DC receivers work better when the VFO is not on the receiving frequency. I also used a different audio output chain.

The most notable feature of this receiver is that is almost totally immune to SWBCI, even when run on an AC supply. Poor AM rejection is a common problem with DC receivers which use an active mixer, and can be quite annoying. I found a Power Amplifier for the transmitter section could be built that puts out 1.5 watts at 7.5V supply, so this rig is optimized for use with a 7.5 to 9 volt supply, making it ideal to run on AA or C cell batteries.

Circuit description:

The values shown are for a 40 meter receiver.

VFO.

This Heterodying VFO is somewhat unique in that it uses a 74HC86 digital NOR gate as the VFO, crystal oscillator and mixer.

The VFO is varactor diode tuned, using 1N4004 diodes. The VFO operates at 4 MHz and has about a 20 KHz tuning range with 5 volts used on the tuning pot. No Doubt a wider

tuning range could be achieved if "real" varactor tuning diodes were used, but 20 KHz around the QRP frequencies should be enough. A Hartly oscillator configuration is used, using the XOR gate as the inverting amplifier. Some of the output is feed back to the input tuned circuit with a three turn feedback coil. The 100 K resistor connected from the input to the output of the gate biases the gate in it's linear region. The output of this oscillator is quite "dirty" with harmonics reaching well into the VHF region. This is not the kind of VFO you'd want to feed into an analog mixer directly!

Tuning voltage for the tuning control is taken from a separate regulator than used to power the 74HC86. It is shown connected to the +5 volt line in the schematic for convenience. The main reason for this is the regulator was getting pretty warm and caused a fair amount of warm up drift as it got up to temperature. It would also be a good idea NOT to locate the regulator for the 'HC86 too close to the VFO parts, another mistake I made when laying out a board for this circuit.

A Crystal oscillator built using another gate in the 74HC86 package. This is a widely used crystal oscillator circuit.

The VFO and crystal oscillator is then mixed in a third gate of the 74HC86 package. The output of this gate has all manor of frequencies, from various mixing products of the two input signals to harmonics of the input signals. It's quite busy looking on a Spectrum Analyzer! The difference of the two input frequencies is one of the dominant outputs of the gate and the rest of the "junk" is cleaned up nicely by passing the signal through a double tuned band pass filter. Mouser 42IF123 10.7 MHz IF cans are used for the Band pass Filter coils. The current through the input coil of the filter is limited with a 100 ohm resistor, which helps keep the coil from saturating and limits the current from the gate.

MOD: Replace R4, the 100 ohm resistor with 100 pF cap. This reduces current consumption by 10 ma!

A simple transistor amplifier on the output of the filter brings the output up to about 1 V, p-p. Supply voltage for this amplifier is supplied through an RF choke to keep the noise generated on power supply line by the 74HC86 to a minimum.

A simple jfet amplifier is used as a buffer between the antenna and mixer. Most of the gain of this stage is derived by the step up action of the input tuned circuit. A 10.7 MHz IF can is used for the input circuit, with a 47 pF cap across the tuned coil to lower it down to 7 MHz. These IF cans are more convent to use than winding a torriod, as we don't need a trim cap to tune them. They also take up less space and are better shielded than the so-called "self-shielding" torriod coils. The Mouser 42IF123 cans are usable from 80 to 15 meters, with an appropriate cap added. They can be use with just the internal cap on 30M, an extra cap added, in addition to the internal cap below 30M and with the internal cap removed and an external cap added above 30M.

the June issue of ARS's (Adventure Radio Society) monthly on-line magazine, Steve Kavanagh, VE3SMA published a very interesting rig called the "Spartan Sprint Spe-

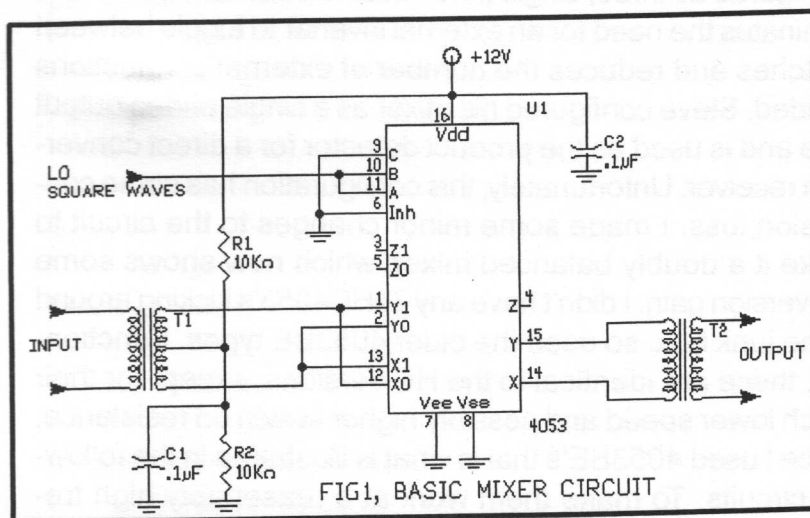

cial". (www.natworld.com/ars/) Steve designed a rig which used many cmos logic parts in a unique way. The part of the rig that struck my interest was his use of a 74HC4053 analog multiplexer switch as a mixer. This mixer is based on the 4066 circuit, who's use as a mixer has been illustrated in various

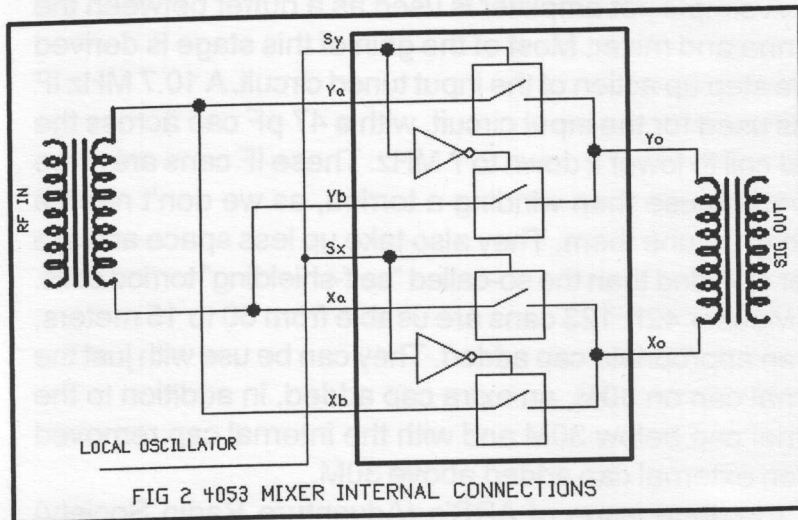

Ham publications over the years. Steve's use of the 4053 simplifies the basic 4066 design, as the 4053 is internally configured as three, single pole - double throw switches. This eliminates the need for an external inverter to toggle between switches and reduces the number of external connections needed. Steve configured his mixer as a single ended output type and is used as the product detector for a direct conversion receiver. Unfortunately, this configuration has some conversion loss. I made some minor changes to the circuit to make it a doubly balanced mixer, which now shows some conversion gain. I didn't have any 74HC4053's kicking around in the junk box, so used the older 4053BE types. Functionally, these are identical to the HC versions, except for their much lower speed and possibly higher switch on resistance. Since I used 4053BE's that is what is illustrated in the following circuits. To make them work at a reasonably high fre-

quency, the supply voltage must be at least 12 volts. With a 12 volt supply, the 4053's will work well up to at least 10 MHz. If higher frequency operation is desired, use a 74HC4053, which will need to be powered by a 5 volt supply.

Here is the basic mixer circuit. R1 and R2 bias the switch gates to 1/2 the supply voltage. The mixer actually works without the bias resistors, but the cap from the center tapped transformer is still needed. The addition of the bias resistors improves the dynamic range of the mixer and the input signal can be quite large, but shouldn't exceed the supply voltage of the chip. The input transformer, T1 can be a trifiller wound toriod, or it can be wound on a small binocular core. Using a binocular core allows for making a turns ratio different than 1:1. This allows making a step up transformer for some passive gain. The output transformer, T2, can also be either a bifiller wound toriod, or wound on a binocular core for a turns ratio different than 1:1. As an audio output product detector, T2 would be an audio transformer. I used a small 600 ohm transformer pulled from an old modem board and it worked well. 1000 pF caps should be added from pins 14 and 15 to ground to by-pass the RF products to ground in this case.

Fig 2 shows the internal connections of the 4053 switch. The mixer simply works by reversing the connections of the input transformer to the output transformer, at the local oscillator frequency. This is exactly the same way a double balanced diode mixer works.

The mixer requires a square wave LO, which is provided by the Q3 amplifier, connected back to the VFO board.

The 4053 Product detector shown in the above circuit uses an audio transformer on the output. I found this could be simply replaced by a resistor and the output feed directly into a differential input amplifier, as shown above. The output of the mixer is rolled off starting at about 1 KHz by the 0.1 uF caps on the output.

There are two main problems with a DC receiver. One

is the very wide response of the output. A lot of filtering is needed to get a good CW bandwidth, without hearing everything for +/- 10 KHz on either side of what your trying to hear! The second is Dynamic Range. A lot of audio gain is needed in order to hear reasonably weak signals. But when a strong station is tuned to, it can drive the audio amplifiers into overload and clipping, making it sound raspy.

In order to deal with the second problem, the gain of the receiver is broken up into two sections, with the volume control between them. This way the volume can be turned down before the second gain stage starts to go into limiting.

The output of the first gain stage goes through a 1 KHz roll off low pass filter and then a band pass filter centered on 700 Hz for additional filtering and peaking up the signal at 700 Hz. This is then followed by the volume control and the second gain stage, which also drives a set of headphones. Rail to Rail CMOS op amps are specified in the schematic. This ensues good dynamic range with running of a 7.5 volt supply. The second op amp is a high current output type, so it can easily drive headphones. It would be possible to use a quad op amp for all the audio stages, but using two separate dual op amps will give somewhat better rejection of high frequency signals, as there is some coupling between the amplifier in a quad package due to the common supply voltage and being built on the same die.

Muting for the receiver is done by using the inhibit feature of the '4053, which turns off the gates. This input is active high to mute. Despite the fact the muting is done before all the high gain stages, there is very little pop or "thump". No doubt this is due to the capacitors on the output of the 'HC4053 holding their charge so there isn't a great voltage change when the muting is released.

Transmitter, PA section

This PA section is capable of 1.5 watts out with a 7.5 volt supply and over 2 watts at 9 volts. Efficiency is about

50%. The down side of having this much power at such a low voltage is the current required is pretty hefty, about 500 ma @ 7.5V.

A 2N3904 is used as a driver (typo in the schematic, oops) This drives the trifler wound transformer needed to drive the gates of the push pull amplifier. Common 2N7000 Mosfets are used for the amplifier. The LED, D3 is used to bias the gates at about 1.7 volts. This provides a reasonably stable bias voltage which is about 1/2 the voltage generally needed to turn the fets on. This reduces the p-p drive voltage needed to the fets, but keeps the bias voltage low enough so that we ensure class B operation and not class AB.

The output of the amplifier is coupled through a bifiller wound transformer, with a separate secondary winding to couple to the output filter. The secondary is 9 turns.

The amplifier is keyed on and off by pulling the base resistor of Q3, a 2N3906 low. Another "oops" is there should be a small, 47 or 51 ohm resistor between the emitter of Q3 and the T4, C18, R14 junction. A 3.3 uFd cap should go from this junction to ground. This provides a ramp up/ ramp down switching on the driver transistor for keying wave shaping.

The plastic TO-92 packages of the fets should be heat sinked. This is most easily done by clamping the packages between two piece of aluminum. Layout the fets so the flat sides are both in the same direction. Cut a piece of aluminum long enough to span between the two fets and about 1" tall. Put this against the flat side of the packages. Cut a thinner strip of aluminum to use as the clamp and drill a hole in the center. Bolt the strip to the bigger piece in back.

RIT and Side Tone.

Not shown is a RIT circuit, which is pretty important in a DC rig. One needs to "zero-beat" a station you want to talk to and then move the RIT to tune them in for a sidetone you can copy, one side or the other of zero beat. There is a spare analog switch gate on the 74HC4053. This could be used to

switch in a RIT pot and associated limiting resistor. For Side Tone, I figure on adding a Paddle keyer chip which generates a side tone and feeding it into the final amplifier stage. Building the circuit.

Laying out and making the receiver on printed circuit boards is probably the best way to go about it, if you have the tools and ability to do so. I've been building it up as modules, a VFO module, Rx module, audio module. All on 1.8 x 1.9" boards, which in theory can all be stacked when it's done. SMT parts are used when I have them, to keep things small.

Building it "dead bug" style over ground plane should also work well, and is how the various sections were first built, tested and tweaked. "Manhattan" style would also work, but takes a lot more time and effort in my opinion.

Other Bands:

It should be possible to build this rig for other bands. The mixer has only been tried as shown, taking an intermediate frequency between a higher and lower input frequency for the output. Will have to try it out to see if one can take the sum of two lower frequencies or the difference of two higher frequencies. But the general rule of thumb here will be to keep the VFO as low in frequency as practical and use a higher crystal frequency to move the VFO to the desired band.

I hope you find this circuit interesting and can use some or all of the ideas in your own rig!

72, Steve KD1JV

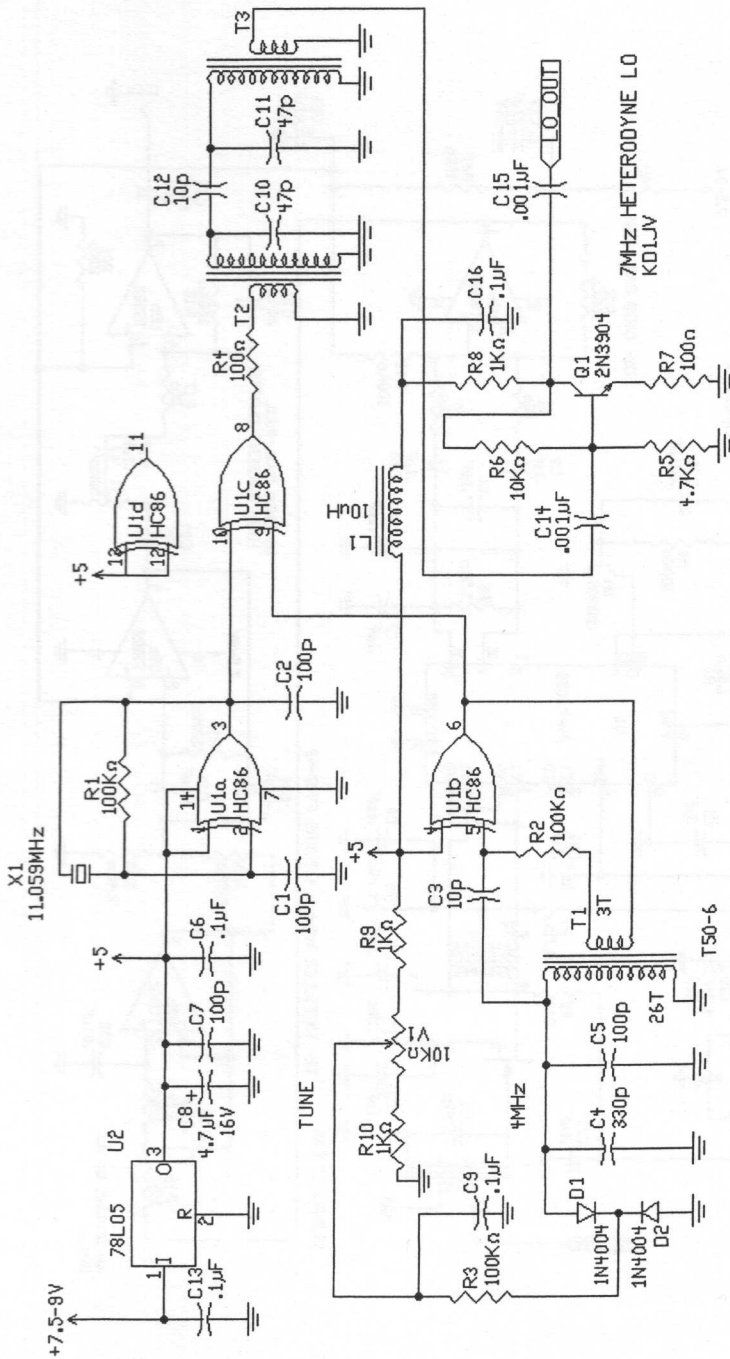

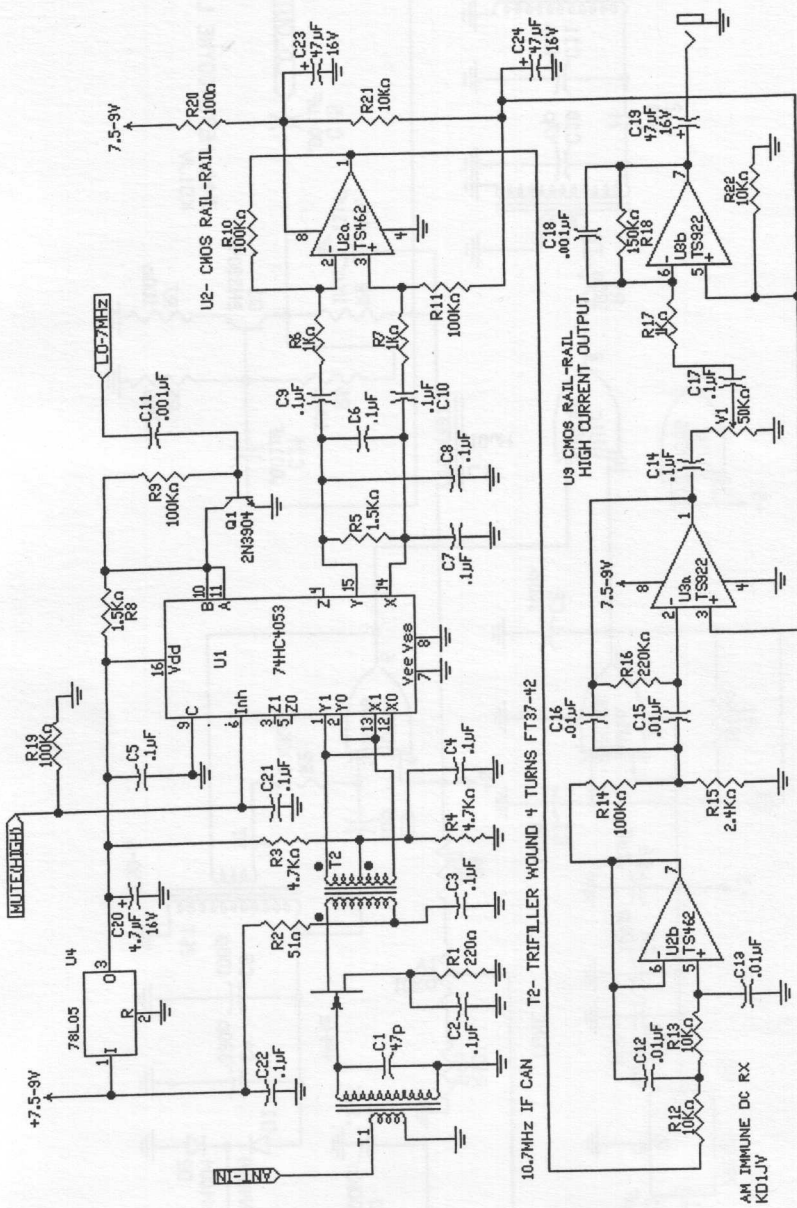

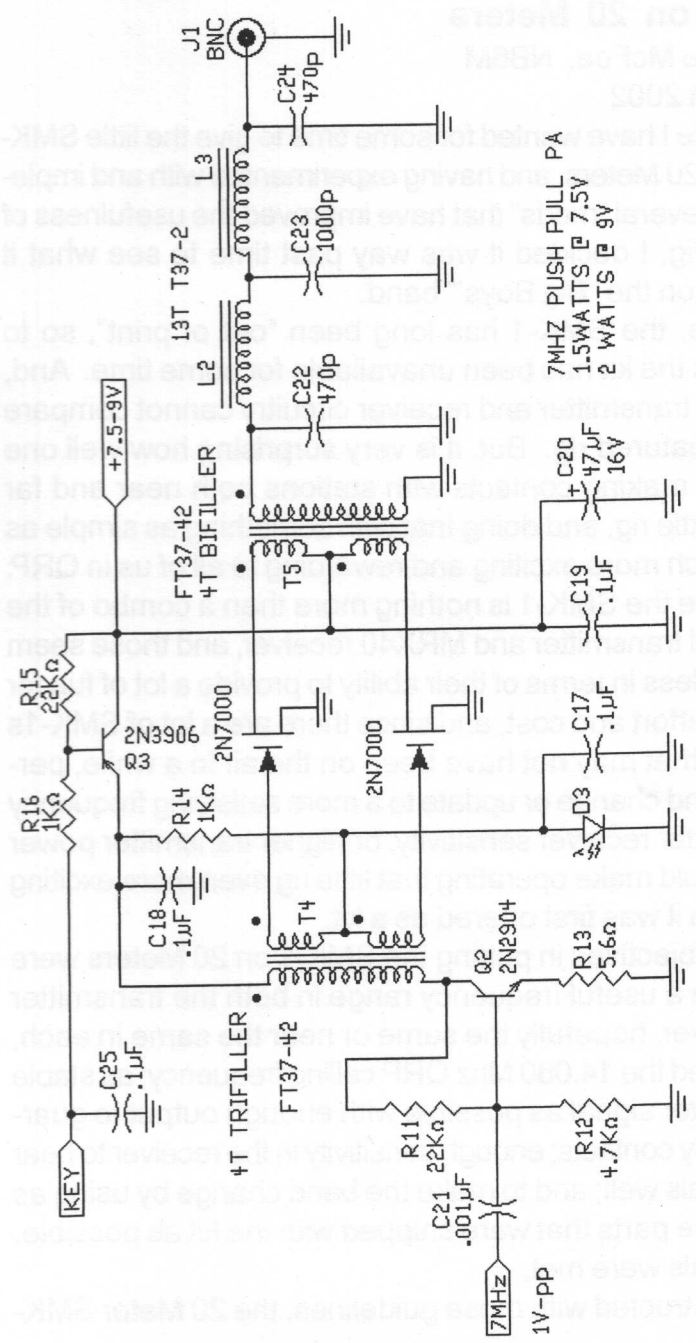

7MHZ PUSH PULL PA
 1.5WATTS @ 7.5V
 2 WATTS @ 9V

SMK-1 on 20 Meters

By Wayne McFee, NB6M

Copyright 2002

Since I have wanted for some time to give the little SMK-1 a try on 20 Meters, and having experimented with and implemented several "mods" that have improved the usefulness of the little rig, I decided it was way past time to see what it would do on the "Big Boys" band.

Sure, the SMK-1 has long been "out of print", so to speak, as the kit has been unavailable for some time. And, its simple transmitter and receiver circuitry cannot compare to a full-featured rig. But, it is very surprising how well one can do in making contacts with stations both near and far with this little rig, and doing that with something as simple as this is much more exciting and rewarding to all of us in QRP.

Since the SMK-1 is nothing more than a combo of the Tuna Tin II transmitter and MRX40 receiver, and those seem to be timeless in terms of their ability to provide a lot of fun for very little effort and cost, and since there are a lot of SMK-1s out there that may not have been on the air in a while, perhaps a band change or update to a more satisfying frequency range, better receiver sensitivity, or higher transmitter power output would make operating that little rig even more exciting than when it was first offered as a kit.

My objectives in putting the SMK-1 on 20 Meters were to achieve a useful frequency range in both the transmitter and receiver, hopefully the same or near the same in each, that covered the 14.060 Mhz QRP calling frequency; as stable a transmitter signal as possible with enough output to guarantee many contacts; enough sensitivity in the receiver to hear QRP signals well; and to make the band change by using as many of the parts that were shipped with the kit as possible. These goals were met.

Constructed with those guidelines, the 20 Meter SMK-

1, using single crystals in the transmitter and receiver VXOs, covers approximately 14053.5 Khz to 14061.5 Khz. Signal reports on the air have been very favorable in terms of stability, and the transmitter, with a hot 2SC799 in the "easy one Watt Mod", puts out almost two Watts.

To help stabilize both the transmitter and receiver oscillators, and maintain the low parts count, 6 Volts regulated was routed from the on-board 78L06 IC to the tuning circuits. In order to achieve a transmitter tuning range equal to the receiver's, the transmitter oscillator was changed to the configuration outlined in my previous work on extending the transmitter's tuning range. It is necessary to cut two PC board traces in order to accomplish the change.

A 10 DB RF preamp was incorporated into the receiver in order to boost its sensitivity to an acceptable level on 20 Meters, while still retaining the same tuned input circuit and diode T/R switching so as to keep the operation of the little rig smooth and simple.

An added benefit of using the already available 6 Volts Regulated to supply the tuning circuits is that only one additional PC board trace needs to be cut, and one extra wire is run from the top of C15 to pin 1 of the 78L06 IC. A comparison of the tuning range in my unit between using 6 volts or 9 volts on the tuning circuits gave surprising results. Very little difference was noted.

A wider tuning range can probably be realized by using larger value inductors in the two oscillator circuits than the 4.7 uH units that I used in this first conversion. I had two surface mount inductors of this value available, even though there is only one in each kit, because of my modifications to other SMK-1s. Further increases in the inductance values would certainly increase the tuning range, but may pull the upper frequency limit below the desired coverage of the 14060 Khz QRP calling frequency.

Although I used all Silver Mica capacitors in the

transmitter's output filter, a variety of high quality, 100 Volt rated capacitors can be used with good success. A prime example of why good quality capacitors must be used in the output filter is that in my unit, when I was using lesser quality caps in the output filter while experimenting with it, and while using the 6 Volts regulated to supply the tuning circuits, I experienced a small amount of transmitter chirp, and at first thought that I was going to be forced to use a better regulator than the 78L06, because when I switched to a 9 volt battery to supply the tuning circuits, the chirp disappeared. Additionally, the transmitter output was lower than normal. However, when I went to all Silver Mica caps in the output filter, not only did the chirp disappear but the output came up to where it should be.

This seems to be a reminder that tuning circuit voltage

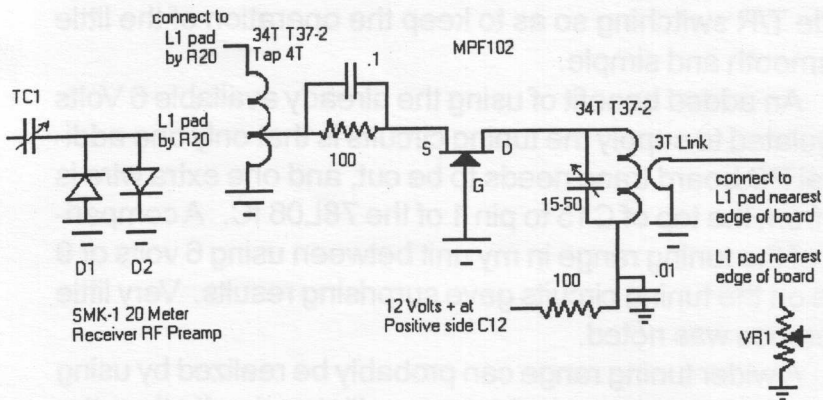

stability and transmitter PA impedance matching and stability work hand in hand in this rig in affecting the transmitted signal note. I am sure that PA heating also has a negative effect on stability.

As mentioned in my prior work on putting the SMK-1 on 80 or 160 meters, converting the rig to another band requires just a few parts changes in the transmitter's output filter network, the receivers input tuning circuits, the crystals and per-

haps the feedback capacitor values in both oscillator circuits. Because of the fact that I did not have on hand any surface mount capacitors of the required values to replace the capacitors in the transmitter's output circuit, and wanted to put a toroid coil in place of L5 in order to support the higher output of later modifications, I used all full sized parts in the transmitter output network.

Full sized parts were also used wherever needed in making the band conversion, extended VXO mod, R14 in the PA emitter circuit, now 2.2 Ohms, and in the entire receiver RF preamp, which I built on the inner copper surface of the left side of the PC board case.

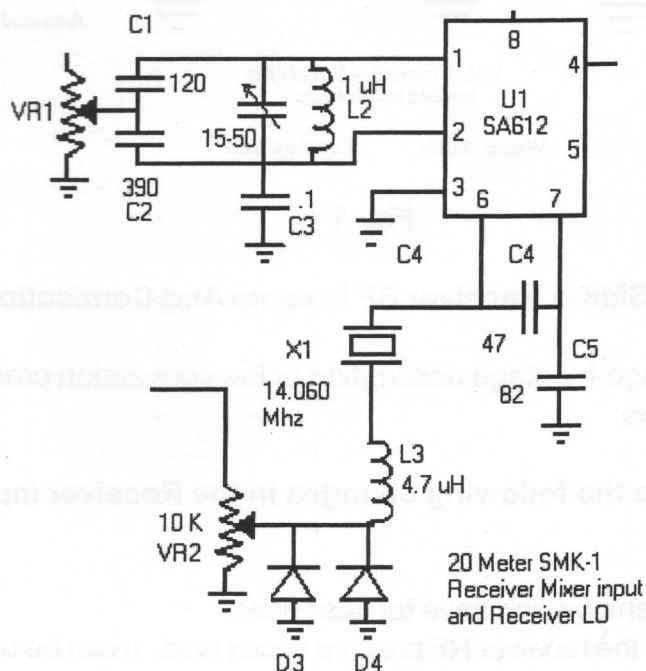

20 Meter SMK-1
Receiver Mixer input
and Receiver LO

Wayne NB6M
Copyright 2002

The eight parts needed for the RF preamp are:

34T on T37-2, tapped at 4T	1
.1 bypass cap	1
100 Ohm 1/4W resistor	2
MPF102 or equivalent FET	1
34T on T37-2, with 3T secondary	1
15-50 (or similar value) Trim Cap	1
.01 bypass cap	1

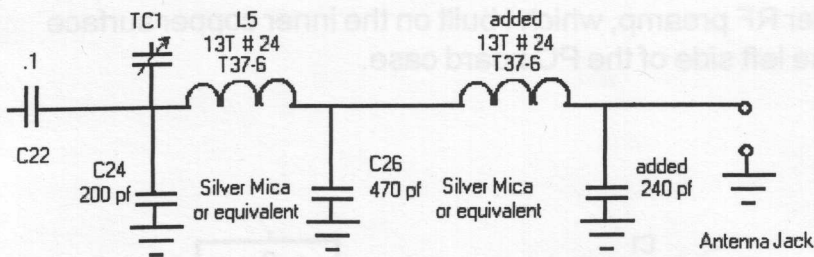

SMK-1 Transmitter Output Filter
modified for 20 Meters

Wayne NB6M Copyright 2002

Fig. 1

20 Meter SMK-1 Receiver RF Preamp And Connections

A stage-by-stage description of the conversion procedure follows:

Make the following changes in the Receiver input circuit:

L1, remove and save for later use.

Build the receiver RF preamp circuit next. It can be built on any available surface of a PC board case, or on a small piece of PC board attached anywhere, if another type of case

is used. "Manhattan" style is quick and easy.

Solder a short piece of insulated hookup wire between the L1 pad closest to R20 and the top of the input coil of the Receiver RF Preamp.

Solder a short piece of insulated hookup wire between the top of the output link of the Receiver RF Preamp and the L1 pad closest to the edge of the board.

C1, remove, save for future use, and replace with a 120 pf NP0 cap.

C2, remove, save for future use. Remove C24, 390 pf, and install it at C2.

L2, remove and save for future use. Remove L5, 1 uH, and install it at L2.

Make the following change in the mute circuit:

R5, across Q2, remove and do not replace. Save the 2 Meg removed for future use.

20 Meter SMK-1 Receiver Mixer and Local Oscillator Changes

Make the following changes in the Receiver LO circuit:

C4, remove, save for future use, replace with a 47 pf NP0 cap.

X1, remove, save for future use, replace with a 14.060 Mhz crystal.

L3, remove, save for future use, replace with 34T on T37-2, or a 4.7 uH inductor.

20 Meter SMK-1 Transmitter Output Network Changes

Make the following changes in the Transmitter output filter:

C24, removed in a previous step, replace now with a 200 pf, Silver Mica or equivalent.

C25, remove, save for future use.

C26, remove, save for future use. If you do not care to put the easy one-watt mod into your rig, replace with a 240 pf, Silver Mica or equivalent.

If you want to add the one Watt Mod, I suggest adding another section of output filter, which will involve the addition of one more T37-6 toroid with 13 turns, and a 470 pf cap will be used to replace C26.

Because I added the second PI section of output filter, I cut the trace between the Ant output connection and C25, ran a short wire from the Ant output connection to the junction of C25 and C22, and connected the added T37-6 toroid between the rear pad of C26 and the top of the added 240 pf capacitor.

This was done in order to move the receiver's RF pickoff point to the input of the TX output filter, so as to make better

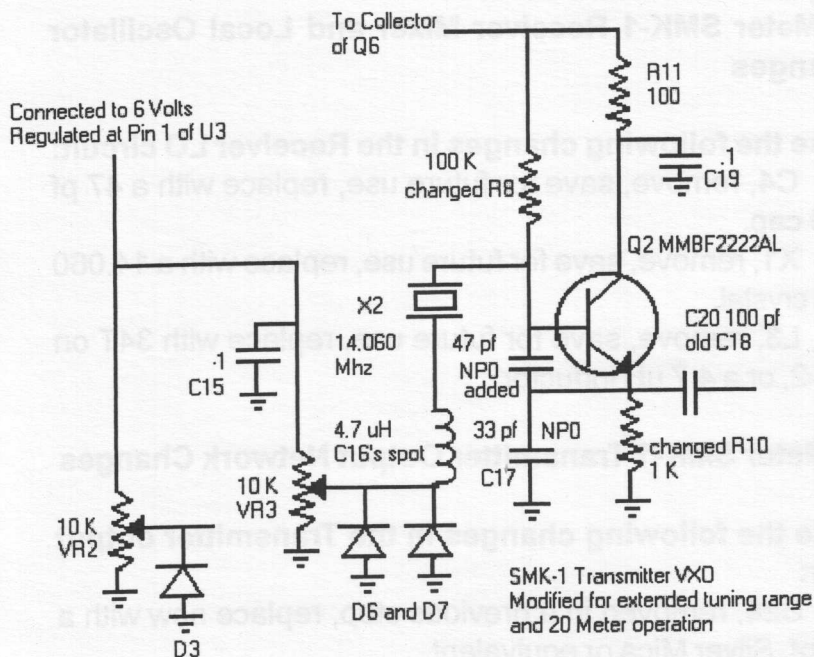

Wayne NB6M

Copyright 2002

use of its low pass filter characteristics.

If you choose not to do the One Watt Mod, the extra toroid coil is not needed, and the 240 pf capacitor will be used to replace C26.

L5, remove, replace with 13T on T37-6.

20 Meter Transmitter VXO with extended VXO Mod

Make the following changes in the Transmitter VXO circuit:

Remove R9, save for future use and cut the PC board trace between the rear pad for the removed R9 and X2, right at the R9 lettering.

Cut the PC board trace between X2 and C20, between the junction of the trace that goes to L4's pad and C20. We want the trace to still connect from X2 to L4's pad, but not to C20 or the collector of Q2.

C18, remove, save to replace C20.

C17, remove and save for future use. It will be replaced with a 33 pf NP0 cap after the next four steps.

C20, remove, save for future use, replace with the 100 pf removed from C18, but installed at a 45 degree angle, between the left pad for C17 and the rear pad for C20, as viewed from the front of the rig.

R10, remove and save for later use. It will be replaced after the next step by 1 K ¼ watt resistor.

Add a 47 pf NP0 cap between the base of Q2 and the left pad (closest to Q2) for R10. The base of Q2 is the contact of Q2 closest to X2, on the side of the transistor that has two contacts. This capacitor, along with the 33 pf cap that replaces C17 provide the feedback necessary for Q2 to oscillate.

Install a 1 K ¼ watt resistor in R10's spot.

Install a 33 pf NP0 cap at C17.

L4, remove and save for future use.

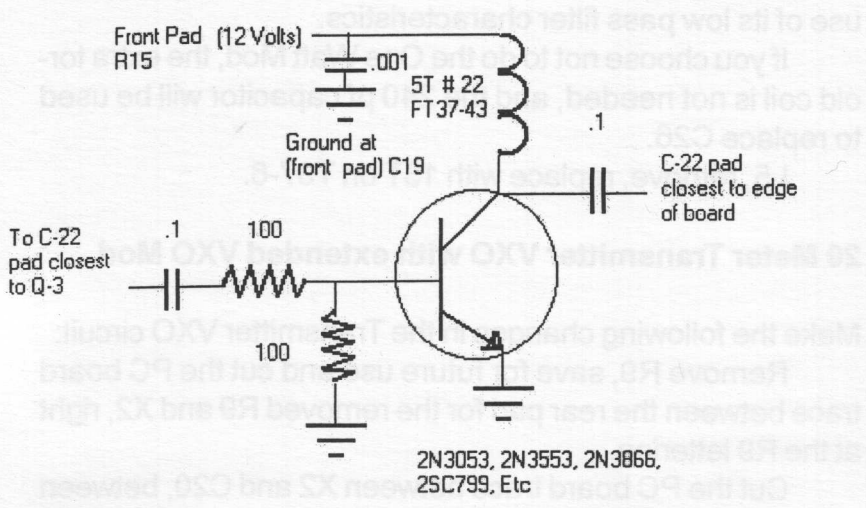

Output will depend on transistor used.

Wayne NB6M
2002

Easy 1 Watt Mod for SMK-1

R8, remove, save for future use, and replace with a 100 K Ohm, 1/4 watt resistor.

C16, remove and save for future use. Replace with 34T on T37-2 or a 4.7 uH inductor.

Solder a short piece of insulated hookup wire between the L4 pad nearest C19 and the C20 pad nearest Q2.

Solder a short piece of insulated hookup wire between the L4 pad nearest C20 and the R9 pad nearest X2.

X2, remove, save for future use, and replace with a 14.060 crystal.

You will note that the extra 9.1 Volt Zener and associated parts added to the VXO oscillator circuit in the original Extended VXO Mod are not used here, as it was determined that they did not add to the stability of the circuit.

Make the following changes to the tuning circuitry:

Cut the PC board 12 Volt trace between the printed copyright "C" and C15.

Solder a short piece of either insulated hookup wire or

cut off part lead between the end of C15 closest to R8 and pin 1 of the 78L06, U1.

If you care to add the easy One Watt Mod, do the following:

You need the following parts to do the mod, plus the 13T T37-6 and the 470 pf cap mentioned earlier in the changes to the TX output circuit:

- two - .1 uf disc or monolithic, etc (bypass cap)
- two - 100 ohm resistors
- one - RF transistor of your choice
- one - roughly 10 uh, RF choke, FT37-43 toroid with 5 turns # 24 (or similar gauge)
- one - .001 bypass cap

I did the mod "ugly" style with all leaded parts, soldering the necessary leads to the pads on the board. Here is what you do:

I suggest you read all the instructions first, to get an understanding of the mod, before proceeding with the actual work.

First, remove C22 from the board. (I used two soldering irons, quick and easy)(save it)

Cut one lead of one of the .1 caps so as to leave about 1/4", bend a 90 degree angle about 1/8" from the end of that lead, and solder that lead to the C22 pad closest to the edge of the board. Leave the other lead long for a moment.

Cut one lead of the other .1 cap so as to leave about 1/4", bend a 90 degree angle about 1/8" from the end of that lead, and solder that lead to the C22 pad closest to Q3. Leave the other lead long for a moment.

Cut one lead of a 100 Ohm resistor so as to leave about 1/4", bend a 90 degree angle at 1/8" from the end of the short lead, and solder that lead to the ground pad of R14.

The idea is to have the resistor standing just about straight up, maybe leaning just a little bit towards Q3. By the way, the ground end of R14 is the pad right at the edge of the board.

Now, using short leads on all three parts, solder the other 100 Ohm resistor between the free lead of the first 100 Ohm resistor and the free lead of the .1 Cap that comes from the C 22 pad closest to Q3.

What we are doing here is providing a coupling capacitor from the output of T1 to the base of the Final Amp we are going to install. The two 100 Ohm resistors form a divider network so as to provide about 2 Volts RF on the base of the Final Amp. The 4 Volts or so right from the output of T1 is way too much drive for the Final Amp and output network we are using, and if we drove it with that much RF, it would overheat and probably self destruct in a short while.

So, at this point you should have a .1 from the C22 pad closest to Q3, connected to a 100 Ohm resistor, which is connected to another 100 Ohm resistor, which is connected to ground.

Position your RF transistor above the existing PA transistor, with the emitter lead towards the edge of the board, the base lead towards the rear of the board, and the collector lead towards the center of the board.

We want the emitter lead to be as short as possible, but the other leads, the body of the transistor and any heat sink used will need to clear the other parts. Remember, the body of the transistor, and therefore the heat sink as well, are connected to the collector, and have both 12 Volts and RF on them. We can't allow the heat sink or transistor body to come in contact with any other parts or with ground. With this in mind, take note of how long the emitter lead will need to be in order to solder it to ground at the ground side of R14. Cut the lead to that length.

Bend the base and collector leads out to their respec-

tive sides of the transistor, close to the transistor body. Leaving the emitter lead pointing pretty much straight down, only slightly bent out towards its edge of the transistor body, bend an eighth of an inch of the lead over at a 90 degree angle, and solder the emitter lead to ground at the pads of R13 and C18 closest to the edge of the board.

Cut the base lead so that it will reach the junction of the two 100 Ohm resistors, and solder it there.

Wind 5 turns of #24 (you could use small insulated wire for this if you don't like scraping the ends of magnet wire) on the FT37-43 core. Scrape about 1/8" of wire clean of insulation at the end of each coil lead.

(This is meant to be about a 10 uh RF Choke. If you don't have an FT37-43, you could use any combination of core and number of turns that gives you roughly that figure. Suggestions are: 35 turns # 22 on T68-2, or 43 turns # 28 on T50-2, to name two.)(Or use a 10 uh RF choke)

The RF choke for the new final amp sits right above R15 and R19 on the board. It should be oriented so that the toroid is at a 90 degree angle from T1 in order to minimize coupling between the two. The two leads from the RF choke should be about 3/8" long.

Before you install the RF choke, solder the .001 bypass cap in place between the 12 volt side of R15 and the ground side of C19. The proper pads of these parts are those that are closest to the front of the PC board.

Then, solder one lead of the RF choke to the 12 Volt side of R15 (front pad). This is just a convenient spot to pick up 12 volts.

Solder the other lead of the RF choke to the Collector of your RF transistor. Check the lead lengths of the two and adjust accordingly before soldering them together.

Now, the free lead of the the .1 uf Cap already soldered to the C22 pad closest to the edge of the board is soldered to the collector of your RF transistor. Check for ap-

appropriate lead length, cut the lead, and solder it in place.

You should place a heat sink on your new final RF Amp transistor.

I added a second PI section to the output filter, by replacing C26 with a 470 pf cap, glued a Manhattan style pad (with 5 Minute Epoxy) to a convenient surface of the rear of the PC board case, unsoldered the antenna lead from the center of the antenna jack on the case, soldered that lead to the Manhattan style pad, soldering one lead of a 13T, T37-6 toroid to the Manhattan style pad, the other end of that toroid to one lead of a 240 pf cap, the other lead of that cap to ground, and connected the junction of the 240 pf cap and the added toroid to the antenna connector on the case of the rig.

The amount of transmitter output will vary, depending on the type of RF transistor used. I got .85 watts out with a 2N3053, and with a hot 2SC799 got almost 2 Watts out. Your mileage will vary.

Tuneup:

When the rig is powered up again, TC1, the trimmer in the RF Preamp output, and TC2 will need to be retuned for highest received signal level. With the values given, very definite peaks should be had on each trimmer. They may need to be retouched a couple of times to ensure they are properly tuned.

Summary:

The drawings included show the circuit details of the added receiver RF preamp, and all the parts changes necessary to convert the SMK-1 to 20 Meters. At first glance, it might seem like quite a bit of work to make the conversion. However, each phase is easily accomplished, and the results are quite pleasing and well worth the effort.

As always, two low-wattage soldering irons and a damp cloth are essential for removing and saving surface mount

parts. I use a jeweler's headband type magnifier and strong light whenever I am working with any surface mount project.

The receiver's ten DB RF preamp brings signal levels up nicely, and is not found to overload the SA612 mixer. No switch was provided for removing the preamp from the circuit as the RF gain works quite well to reduce receiver gain whenever appropriate. R5, the sidetone pathway across the receiver's muting transistor, Q1, was removed and not replaced. With the RF Preamp in place, there is enough leakage of the TX signal across Q1 that the sidetone is quite audible at any reasonable gain setting, and is actually just a little too loud at the maximum RF gain setting. A 4.7 Meg Ohm resistor was put in R5's spot as an experiment, but was not sufficient resistance to lower the sidetone to a comfortable level at high RF gain settings.

I have added an 800 Hz active audio filter to the output of the LM386 in my SMK5Watt 40 Meter rig, which can be switched in or out as desired, and have been so pleased with the available selectivity that I plan to add one to this rig as well. It will be particularly useful in helping the receiver reject nearby strong signals, as well as getting rid of the high pitched QRM of signals further away and elevating the chosen signal above the noise level.

On the air results with the little rig, even at the half-watt level, have been very satisfying. The first QSO with the little rig was with Ricardo, XE2RN/QRP, in La Paz, Mexico, who was running 5 Watts and was Q5 and a good strength 7. I was especially pleased with the contact, as La Paz is one of my favorite ports in the Sea of Cortez, which I visit regularly in my sailboat.

Another QSO of note was with Don, K5QK, in Louisiana who reduced his transmitter power to 500 Milliwatts to match the output of the SMK20, and his signal was still Q5 and solid copy during the remainder of the contact, which lasted several minutes longer. This speaks well of the sensi-

tivity of the receiver.

Since those first contacts, I have added the easy One Watt Mod to the rig, and now have over 1.5 Watts of output, which is enough power to guarantee contacts any time the band is open.

Further experimentation is in order using dual crystals in the VXO, and perhaps changes in the inductance values used in series with the crystals, in order to optimize the frequency range and band coverage.

Future additions to the SMK20 will include the audio filter mentioned, a Tick keyer, and, at a later date, perhaps the 5 Watt Mod. For now, I am enjoying operating the rig at the one watt, plus, level and have continued racking up the contacts.

As mentioned above, any or all of these modifications to the SMK-1 can easily be applied to the Tuna Tin II and similar transmitters, as well as the MRX40 and other types of receivers, with corresponding benefits.

I hope to see you one the air around 14.060 Mhz.

Enjoy.

Wayne NB6M

Copyright 2002

Introduction to the Electroluminescent Receiver

By David White, WN5Y

It seems that as Hams get older, the boards get smaller. I thought a receiver made from an NE602 portable phone chip was small until I saw English kits to "learn about Surface Mount Technique." The curves have crossed and it's time for an upturn. So I designed a competition grade receiver for the Ham band, or any bands, on two huge screened boards (8 ½" by 8 ½") that you can cut down to six really big ones if you

insist. The interconnections are infrared and there are 21 functional LEDs that add to the circuit, not just tell you when it's on.

I can show you how to make an LED DBM that will make your eyes hurt if you stare at it, like a 6V6, too. And this radio has all the audio the average ham can use.

This introduction will explain the LEDs, give a circuit description, discuss highlights of each board, and list the design features that help build the kit.

Why the LEDs?

The LEDs are used for diagnosis, indicators, and visual inspection of oscillator injection levels. All the current of the MOSFET circuit travels through the LED. Therefore, mistakes in the MOSFET circuit show in the brightness of the LED. After building a "dead bug" prototype, I discovered that I had not touched the oscilloscope. The LEDs with the amplifiers and mixers are used for diagnosis. The amplifier LEDs flow 5 mA and the LEDs on the variable gain amplifiers will go dark as the gain of the amplifier is turned down. An LED very bright, dim, or off means inspection of the circuit for errors. The mixer LEDs diagnoses the oscillator/amplifier chain. Gate 2 of the MOSFETs is at .5 volt, which turns off the device, and only when oscillator injection is present, will the LED turn on. The LEDs give a visual indication of oscillation injection levels that are easy to gauge and reset. Indicator LEDs are used at the bandpass and crystal filters, VFO, and crystal oscillator. Super-brights can be used in many of the locations to increase the visual impact of the receiver.

Circuit Description

The receiver is a dual dual-conversion, dual dual-image superhet receiver. The switching IF's are dual imaged with a high side LO, using a relay switched Tesla VFO [1]. The IF frequencies are 455 KHz apart, allowing conversion to a 455 KHz tail end IF strip. Bands covered are 40/20 Meters (with the 3.547 MHz IF), and 30/17 Meters (with the

4.000 MHz IF). An RF amplifier sends signals through a varicap tuned bandpass filter [2], to the first mixer, and out through a ladder crystal filter to the second mixer. A crystal oscillator, switched by a crystal filter IRED, secures a 455 KHz output from the second mixer to the 455KHz IF strip. AGC controls signal levels to a Schottky diode ring product detector, yielding audio with a 455 KHz tunable BFO and amplifier. An adjustable gain pre-audio amplifier drives a TDA2002, an 8-watt car audio amplifier. The VFO is tuned with a five-section variable capacitor, making bandspread changes easy. The receiver comfortably tunes the lower 150 KHz of the 40/20 Meter bands and all of the 30/17 Meters bands without the use of a reduction drive. VFO frequencies are 14 MHz (30/17), 10.545 MHz (40), and 10.455 (20).

First PCB Board

The first board features the front end of the receiver: input section, VFO section, and first mixer/crystal filter section. The highlights of this board are the RF amplifier, variable bandpass filters, and the first mixer. Also, the control center for the infrared switching is located at the input of the crystal filter. The best high-level RF amplifier ever designed, the post-mixer amplifier for the Progressive Communications Receiver [3], is used as the RF Amplifier. The Bandpass filters [2] tune 4.4 MHz to 21 MHz. A 50K pot tunes both bandpass filters, with relay switching, controlled by IR (infrared) devices to improve input/output isolation. The first mixer is a four MOSFET mixer/amplifier combination. Gain is approximately 14 dB with adjustable sensitivity and dynamic range. As VFO injection is increased, by a 100K pot at the first VFO amplifier, the sensitivity of the mixer is increased and dynamic range decreased. This allows the receiver's sensitivity and dynamic range to be varied according to the antenna used and band conditions. Two ladder crystal filters [4] finish the first board. The input switching of the crystal fil-

ters is the control center for the Infrared band switching of the receiver. A high power IRED [5], at the 4.000 MHz filter, turns on a Phototransistor at the Crystal Oscillator so the output of the Second Mixer is always 455 KHz. Another high power IRED is switched on at the 3.547 MHz filter that controls the VFO frequencies. The IRED switches on a 10.545 VFO relay, which turns the receiver to 40 Meters. This same Phototransistor, located between the VFO amplifiers, gives power to a 10.455 VFO relay, which is switched on by a Photodiode activated by an IRED when the 20 Bandpass filter is selected. This action turns the receiver on for 20 Meter reception.

Second PCB Board

The second board features the second mixer, crystal oscillator and amplifier, 455 KHz IF strip with AGC, product detector, BFO and BFO amplifier, and two audio amplifiers. The highlights of the second board are flashing IF strip LEDs, S-meter flexibility, and two gain adjust points to control the audio level. There are two AGC controlled 455 KHz IF amplifiers, and one 455 KHz amplifier for the AGC detector. The LEDs of the two AGC controlled amplifiers will flash with the level of the received signal providing a built in S-Meter. The LEDs will be brightest when the MOSFET's Gate 2 voltage is 6 volts (no AGC) and off at 0 volts. An S-Meter output was provided, and the circuit can be adjusted for meter movements from 50uA up to 500MA. It is highly active, so weak signal reception can be aided with the S-Meter. The variable gain BFO MOSFET amplifier sets the injection level to the product detector. Running this amplifier at it lowest level, with the LED just barely on produces the quietist receiver. An adjustable gain pre-audio amplifier follows the product detector output filter. A "Gain Adjust" emitter bypass capacitor [6] is marked on the board to adjust the drive to the TDA2002. No capacitor is good for home use, a 2.2 mfd in a noisy envi-

ronment. The excitement of this board is the AGC controlled LEDs, (that flash along with CW signals), adjustable audio amplification, and I almost forgot, an LED DBM that you better not stare at with the bare eye. Replace the four Schottky diodes at the product detector with Super-Bright LEDs (blue is my favorite), raise the value of the coupling capacitors (BFO out -3.3pf to 100pf, amp out - 47pf to .01), and stand back. Have your sunglasses handy.

Building Aids

The PCB is a single sided design, the traces are .50" wide. All the soldering points were enlarged while trying to keep soldering bridges to a minimum. Solder checks are done by looking for light shining through a hole, which means a missed soldering point, or an incomplete soldering job. Without a solder mask, solder has plenty of room to flow properly, giving a smooth appearance and easy identification of bad joints. Each board is three sections, with holes defining each section, giving six smaller PCB boards, which can be individually shielded in PCB boxes. Or small shields can be installed along the holes. The mounting holes in the PCB boards are aligned for easy stacking, either whole or split apart. The topside of the board has a complete silkscreen, for easy location of parts. Important instructions are silkscreened on the board, so a hurried person would not miss important points. The most common parts, 95 .01 caps, 32 100K resistors, and 28 100 ohm resistors, all have the part number inside the footprint for easy identification. Spend two hours stuffing the parts, the boards will look half-done, and give the inspiration to keep going on to completion. Each board takes about 6 hours to complete. Instructions are on a CD-ROM, which allowed plenty of pictures and thorough instructions. The receiver is designed to work without a case. In place of a case, an unetched PCB bottom plate is included for mounting the boards, and mounting all the connectors for

B+, speaker, and antenna. The main tuning capacitor has a solderable frame and is soldered on the bottom side of the PCB, underneath the VFO, for a very sturdy and stable mounting.

Conclusion

It is time to put a kit together that you can see, easily place parts, and have the freedom to modify and improve without major hassles. The result is a very good receiver that can be a working base for experiments, improvements and learning. The LEDs bring important contributions, but after the receiver is working, also contribute to an exciting look. Saving 500 mA on a desk lamp is another option. With the large board sizes, and distinct outlines of each individual circuit, it is an extensive, but easy kit to put together, while familiarizing you with the circuits that make the receiver "bring in the signals".

Footnotes:

[1] The name for the VFO, "Tesla Oscillator", comes from the April 1999 issue of QRP Quarterly, Chris Trask, N7ZWY, "LC Oscillators - A Brief History". The more common name for the VFO is the Vackar VFO.

[2] September/October 2000 issue of QEX, "Narrow Band-Pass Filters for HF", by William Sabin.

[3] Wes Hayward, W7ZOI, and John Lawson, K5IRK, "A Progressive Communications Receiver," QST, November 1981, Page 11.

[4] "Designing and Building Simple Crystal Filters", by Wes Hayward, W7ZOI, July 1987, QST, Page 24

[5] Individual IREDs are part number LED1067, Page 8. (T-1 3/4", 1.3V, 1A peak, 100mA continuous, 940nm, 16 degree viewing angle, clear package). BG Micro at <http://www.bgmicro.com>

[6] <http://www.rason.org/Projects/bipolamp/bipolamp.htm> This site is all about audio amplifiers, and the kit pre-audio ampli-

fier was designed from the information here. The Electrolu-
 minescent Receiver kit web site is at <http://www.nwtexas.com/>
[usr/r/receivers](http://www.nwtexas.com/usr/r/receivers) or <http://www.ai.com/receivers> The price of the
 kit is \$89.95 plus shipping. Ordering information is on-line at
<http://www.nwtexas.com/usr/receivers/elrorderinfo.htm>, or
<http://www.ai.com/receivers/elrorderinfo.htm> or write to David
 White, P.O. Box 71, Pampa, Texas 79066-0071. Email:
 wn5y@yahoo.com

QRP To The Field 2002: Water World Deja Vú

by Jan Medley, N0QT, NorCal Contest Manager

Marine Mobile Stations

Call	Pts	SPC	Loc	FINAL
W5KID	1275	45	5	286,875
NQ4RP	1080	42	5	226,800
KG6ECI	590	55	5	162,250
N3AO	390	28	5	54,600

Ocean Stations

Call	Pts	SPC	Loc	FINAL
KØZK	1035	56	4	231,840
K2QO	795	44	4	139,920
W3CD	580	32	4	74,240
N9WW	350	21	4	29,400
AD6JV	400	18	4	28,800
ALØHA	190	11	4	8,360
K5MGJ	20	2	4	160

Other Waters Stations

Call	Pts	SPC	Loc	FINAL
K5OJ	1700	67	3	341,700
N4DD	1440	63	3	272,160
KIØII	1045	53	3	166,155
WUØL	1200	41	3	147,600

K4JSI 745	40	3	89,400	
W3IYQ 815	31	3	75,795	
WØUFO	745	32	3	71,520
KN5TX 650	32	3	62,400	
NK7M 520	33	3	51,480	
W1PID 1165	10	3	34,950	
K3WW 390	24	3	28,080	
W5TB 425	21	3	26,775	
NA5N 295	22	3	19,470	
N7CEE 285	21	3	17,955	
W3ANX 235	18	3	12,690	
NN5E 245	11	3	8,085	
KV2X 205	13	3	7,995	
NØQT 130	9	3	3,510	
VE6QRP	135	8	3	3,240
K5HWT 75	4	3	900	
W1QHG	40	3	3	360

Field Stations

Call	Pts	SPC	Loc	FINAL	
W4GGM		780	46	2	71,760
N6WG 615		28	2		34,440
WD7Y 570		30	2		34,200
AD6GI 490		23	2		22,540
WA4CIT		375	22	2	16,500
KW4JS 235		15	2		7,050
W1OH 230		13	2		5,980
JR1NKN		130	3	2	780 (JA DX)

Home Stations

Call	Pts	SPC	Loc	FINAL
K5KW 1380		50	1	69,000
K7TQ 1220		49	1	59,780
K8CV 405		20	1	8,100
HP1AC 320		21	1	6,720
NQ7X 305		22	1	6,710
K8HJ 225		13	1	2,925
VE5RC 200		10	1	2,000

Check Logs: K7GT, N8WE

QRP Soap Sudz

AD6GI: Heavy rain, drizzle, scattered clouds and sunshine at various times. Only needed snow and sleet to complete the list. Several reports on the reflectors showed others getting that part, though. Great plans to do WT and all set to go, when heavy rain started. Plan B put into action. Still had a great time and am ready for next TTF. Tnx to those giving me a call. 'Tis much appreciated.
[K2; PW-1 on tripod]

AD6JV: Great fun as usual!
[K2; ???????]

ALØHA: Food, fun, fellowship and onlookers KH6IMB, KH6BMM, W6ORS, AH6NK, KH6AFQ, KH6FKG, NH7D, KH7SO, KH6JRM, KH7FV, WH6LU, AH7G, NH6OW, AH7A); we celebrated the 10th Annual Moku Ola Island DXpedition 27 April, 2002 with ALØHA call.

[K2; vertical quad loop]

{uh-huh, sure...this was a PARTY not a Dxpedit! I saw the site permits...you ain't foolin' me! - Ed.}

HP1AC: [IC-706MkIIIG; TA33JR]

JR1NKN: Went to a park on top of a hill by bicycle early in the morning. Very happy to have QSOs with stations in the states in the contest. I was excited and had a fun (time).
[FT-817; loop]

KØZK: You have to read the "Tale of the Salty Dog"...what fun! -Ed. [K2; 25' vertical w/#22 wire radial into salt water]

K2QO: We (Mark, K2QO and John, W2IV) had a great time operating from the shores of Lake Erie near Angola. We used

an FT-817 and LDG QRP tuner. We'd previously fiddled with a compact 3-band yagi, but its performance was no match for a doublet high over the lake. The marine battery was overkill. Next time we'll go with a couple 7Ah gel cells.

[FT-817, 66' doublet]

K3WW: I have several ponds and a spring and springhouse in my back yard, and operated from my gazebo, where I can watch the fish and ducks.

[K2; 300 ohm-fed dipole ala QST a few months ago]

K4JSI: As always, I thoroughly enjoyed QRPTTF, this being my fifth outing.

[Ten Tec Argo 556; 20m half-square end fed]

K5HWT: [SW-20; dipole up 25' on DK9SQ pole]

K5KW: Twenty was clearly the band of choice in my area. Plans to operate Class WT fell thru at the last minute, so made do at home. Great fun!

[IC-756 Pro; G5RV]

K5MGJ: This was my first field op and I was on a business trip and only had about an hour to operate. It's only 3 QSOs, but they were hard-fought and a joy to get. The lighthouse keeper was kind enough to walk my camera up to the top of the lighthouse to snap the photo.

[FT-817; MP-1 vertical]

K5OJ: Conditions a little better than last year. Lots of curious visitors this year. Thanks for the fun! [K1 x2, K2 x2; 10m stacked dipoles, 15m stacked dipoles, 20m 2-ele yagi, 40m dipole & vertical]

K7GT: Not bad for 2-1/2 hours! Stinko wx and a head cold

kept me at home this year. Took breaks and worked on the new operating console.

[Omni 6, DX77 vertical]

K7TQ: [K2; Force 12 C4S]

K8HJ: [S&S Ark-40; dipole]

KG6ECI: [K2; long wire]

KIØII: That was fun in the sun and wind. Setup at a picnic area on top of the dam at Chatfield Reservoir (CO), and (watched) sailboats battling the white caps (while) trying to keep track of my paper log blowing in the wind. [none given]

KN5TX: Had a great time on the banks of the Sloan Creek Tributary. Food was great, company was superb and weather was typical Texas - cloudy and humid, then sunny, then steamy with lots of caterpillars. Bands were not in real good shape, but adequate. Most productive was 20m. Looking forward to doing it again next year. [none given]

KW4JS: I had lots of fun in 2 hours - not bad for rain and a new 4-week-old harmonic (son). Thanks to everyone! [K2; random wire]

NØQT: Did I mention the wind? [FT-817; Hustler verticals]

N3AO: Really had fun - great contest! Great wx too. Some really strong sigs. A frog jumped into my canoe! [K1; inv vee]

N4DD: Our operation was conducted at Bays Mountain Park and Planetarium. Equipment included a K2 with autotuner and 40m dipole. We also utilized the QRPDUPE logging software. Operators were Dennis (N4DD), Luther (N4UW),

and Dan (N4ROA). [K2; 40m dipole]

N6WG: Conditions were pretty thin out here on the left coast. Worked everything I heard. Had a great time, though temp was more appropriate to FYBO. [K2, 40m dipole]

N7CEE: Plans to operate from a sailboat on a central Arizona lake were scuttled at the last minute due to winds, so Friday afternoon I set up near a spring in the Mogollon Rim Country. A short but very windy storm hit that evening, but much to my amazement the #26 wire antennas were still up. Signals were down and the pace slow at my location, so I alternated reading with contesting. Per NA5N's suggestion, I checked 10m on the hour, and others seemed to be doing the same. Great idea, Paul! I'm looking forward to next year's theme. [K1; 270' horizontal loop, 170' end-fed wire]

N8WE: [SW-20; auto whip mounted on plastic auto hub cap]

N9WW: Weather deteriorated dramatically and I ended up operating from the car for much of the contest. Wire antenna was tossed into trees above my operating position and a counterpoise was run along the curb. Glad to give out the "OC" to all I worked. The lakefront is only about 2 miles from my home QTH and I should operate from the park more often when the weather is good. If only it were salt water... Thanks for organizing a fun contest - I'm psyched for this summer! [K1; 75' end-fed wire up 25']

NA5N: Did I mention the wind? [FT-817; Spider vertical]

NK7M: Most fun this year! Even with poor antenna set up. Heard lots of sigs, made good contacts. [K2; random wire]

NN5E: My first QRPTTF, but I didn't have much time to oper-

ate. Also my first outing with K2 #2234. I'm still tweaking it but audio filter and ATU seemed to work. Only worried about the 554 report, hope I didn't sound that bad! [K2; MP-1]

NQ4RP: The promise of hot activity on 10/15 didn't pan out...in fact, all bands were pretty crummy. Still, we worked 42 SPC/bands for 30 states 2 VE and Panama. After 5 hours, getting a QSO seemed like work, so we hung it up. Especially fun to work W5KID and AJ4AY, and Knightlights Club, WQ4RP. [K2 x 2; 300' long wire, SLV, W3EDP long wire]

NQ7X: [TS850s; 3-el triband beam]

VE5RC: Thanks for a nice contest. Maybe I'll work you next year from Wascana Lake, too cold this year! Hi! Luv my new K2! [K2; 2-el tribander]

VE6QRP: [none given]

WØUFO: Worse than FYBO...snow, rain, cold wind...but, of course, fun! Got cold and wet so never worked 40m as planned, nice to hear everyone.
[MS-15, NC-20; 40m dipole, zepp]

W1OH: Had a good time; set up on the grounds at Woods Hole Oceanographic Institution (where I work); about 1/4 mile from Vinyard Sound, so called it a FD operation since I couldn't see water from the newly cleared formal garden (part of the old estate where the Institution buildings are now). Nice sunny, cool day! [Sierra; Norcal doublet & BLT]

W1PID: I rode my bicycle several miles to an isolated spot on the Pemigawasset River in Sanbornton NH. A perfectly beautiful spot. Bands were disappointing. Not as much activity as I expected. Still had a fantastic time. Thanks to all for

the contacts. [DSW-40, DSW-20; dipole]

W1QHG: Safety violation? Did antenna work with 5-month-old baby in one arm? Operated alongside Red Maple Swamp. [K1; wire and counterpoise]

W3ANX: Good wx - suffered from switcher p/s hash from logging PC! A good shakedown for FD in June... Now to get a better antenna, and fix the hash problem.... [K2; St. Louis Vertical]

W3CD: I found a slightly better site which was more removed from general foot traffic. It was a great RF location and offered spectacular views of the Bay area. When the action got slow, all I had to do was look to my left for a pleasant diversion! [K2; 20' vertical, mesh fence counterpoise]

W3IQY: Great time at Brandywine Park. Always enjoy QRPTTF. [K1, Sierra; 100' CF Zepp]

W4GGM: A Maury Amateur Radio Club effort! Wx looked bad but only got rained on a few minutes and the ticks weren't as bad as expected. It was fun playing radio on a 30-acre hill. See y'all next year. [K2, K1, FT-900; 40m dipole, 20m dipole]

W5KID: Great pics of the USS Kidd, DD-661 in Baton Rouge LA.

W5TB: Thanks to all, always a fun time. [K1; 40+ ft long wire]

WA4CIT: My first attempt at this contest. What fun! I was surprised how quiet 40 meters was, especially during the first couple of hours. [none given]

WD7Y: Much better results than last year, but nothing to shout

about. I was hopeful for 60 or more QSOs but only to wind up with 48. Maybe conditions were poor again, I wasn't able to work one station on 10m. I have worked QRPTTF for the last five years and always enjoyed the event, this year may not have been a banner year but still had a wonderful time. [K2; 135' zepp]

WUØL: Thanks for a great contest. It was a beautiful day in the Colorado mountains. [Self-design homebrew 40/20; G5RV]

W6QIF Oscillator

by

Jim Pepper, W6QIF

I have always been interested in oscillators.(1) They are the very heart of both the receiver and transmitter. There are several things that are important to their operation, i.e. their frequency stability which includes their temperature stability, the method of tuning the circuit, the mechanical stability, the effect of loading on the circuit and purity of signal.

Being mainly concerned with the frequency stability as a function of temperature, I decided to build a crude oven where I could place various components of the oscillator to see how they were affected by varying the temperature. The oven consisted of a cardboard box lined with styrofoam for insulation. The heater element was a 25 watt 25 ohm resistor connected to a 12vac source dissipating about 5 watts. I used a digital thermometer to record the temperature.

I previously had tested COG and NPO capacitors and they all performed to spec with very little change from room temperature to 100 degrees F. The polystyrene capacitor has a negative tempco (its capacitance decreases with increase

in temperature). This time, the element I tested in the oven was coils wound on a T50-6 toroid form. The inductance was about 2 μ H. The test was made with an oscillator using a 74HC04 Hex inverter operating at 7mHz. I first used this design in my P40-30 transceiver design.(2) I didn't realize it at first, but I had, unknowingly, built up the well known VACKAR oscillator circuit. The original VACKAR circuit uses a bipolar transistor as the amplifying element. Instead, I used one element of the Hex inverter. The other sections of the Hex inverter are used for isolation. The one reason I first used this circuit was that the coil didn't require a tap or special input capacitors to provide the necessary feedback requirements. It made it easy to switch coils to give separate band operations. (See basic Circuit Figure 1).

The T50-6 toroid was chosen, based on other articles on toroids, as being the least temperature sensitive and the most readily available. I didn't try any other types.

I first checked, in the oven, the toroid coil that was just newly wound. I found typically it ran between a positive 45 and 60 Hz per deg F at the operating frequency of 7 MHz over a range of 60 to 100 degrees F. Then I boiled the coil in hot water for 5 minutes and again ran the same test over the same range. The results indicated that there was very little difference between the two but interestingly the tempco was now negative. In other words the frequency went up with increasing temperature by about the same value. I also tried coating a virgin coil with DuCo cement. The results were not that much different from the virgin one. I did these tests on three virgin coils with similar results. This is not to say that it may be good practice to do these things but they may not be necessary. I think coating the coil should be done from a mechanical viewpoint. Next I checked the MV104 to see what effect the temperature had on it. It was the only element

FIGURE 1
W6QIF OSCILLATOR

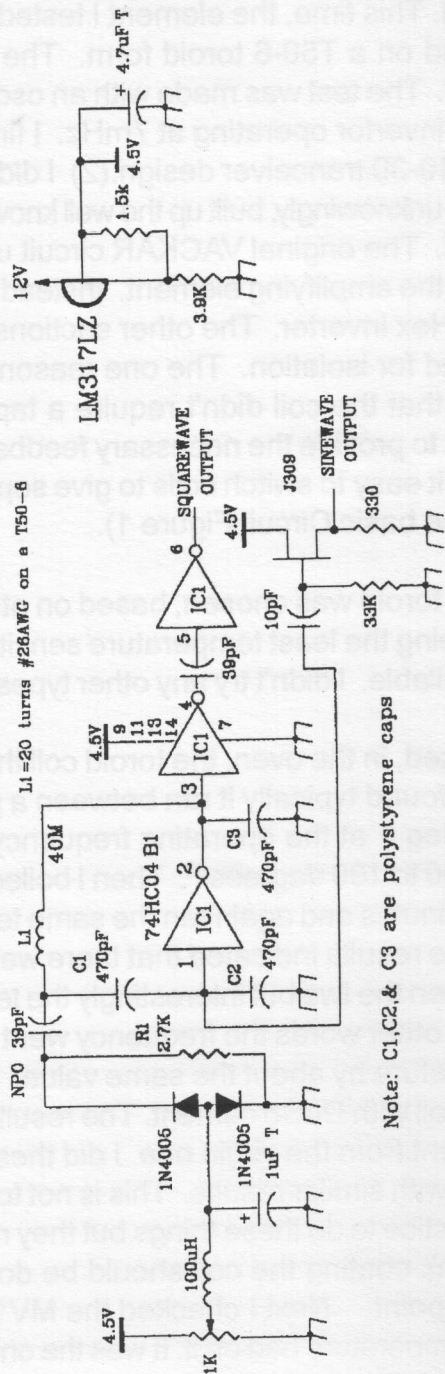

Note: C1,C2,& C3 are polystyrene caps

in the oven. The MV104 showed a tempco of positive 50 Hz per deg F (7000kHz) at the low end (bias voltage =zero) and a negative 125 Hz at the high end (7100kHz) over a similar temperature range. (This is logical since the effect of the MV104 is less at the high end in comparison with the other more controlling capacitances of the circuit which were causing temperature changes.) In other words, the frequency went down at the low end as the temperature increased and vice versa for the high end. Thus, at some point in the band, the tempco was zero. At this time I noticed that using a step change from zero to a plus voltage on the bias on the MV104 resulted in a slow drift in the frequency after the change had been made and then reached a steady state. The change was several hundred Hz. I changed the input resistor to the MV104 to a higher value thinking that the current into the unit was causing some internal heating. I didn't seem to make any difference. This probably wouldn't be of any concern in normal usage of the unit, but it was an interesting observation.

Because of this problem, I decided to see if using 1N4005s, in a similar configuration, would do the same. They didn't but, as luck would have it, I didn't connect the cathode to cathode together as is the case with the MV104 but just the opposite.

When I tried out the circuit in the oscillator, I found that the zero voltage gave a frequency at the high end and the high voltage at the low end. Just the opposite of the MV104. But I did notice something even more important, the bandwidth change was about 2.5 times that of the MV104 indicating a much greater capacitance change. I decided to call this vericap version a MVP40@30 since it will be first use on the P40-30 receiver. (See Fig 2 for a comparison of bandwidths compared to the MVP40-30. The same component values are used for each case). Well this sounded pretty good but how about the linearity? The MV104 wasn't that great so

maybe the 1N4005s wouldn't be good either. To my surprise, they were much better (See Fig 3) (The test was made with the 1N4005s circuitry adjusted to give the same bandwidth coverage as the MV104.) I followed up the above test using the diodes connected the same as the MV104 and found results were poorer than the MV104. So you see, some times luck beats brains.

FIGURE 2

VERICAP #	BW
MVP40-30	184Hz
MVAM109	85Hz
NTE618	35Hz
MV104	82Hz

Connecting the diodes, in this fashion, apparently acts as a variable resistor in series with the tuning capacitor that is controllable by a varying voltage. (3) The capacitance is maximum with zero resistance in series which occurs when there is maximum conductance through the forward biased diodes, ie when the voltage of the bias is maximum. (Note: In the QRP CLASSICS (4) a statement is made that the change in capacitance is quite non linear below approximately 2 volts for a MV2109 which is similar to other varicaps of this style.)

It turns out that it appears this way on the curve shown on page 112 but if you note carefully the graph is not linear in this region and if look at the actual change in capacitance from .2 to 3 volts, is fairly linear. It is only when you get to the

voltage of 3 volts and up it becomes non linear. This is the end you want to stay away from. In order to do this, the required change in frequency desired should be obtained by using a larger capacitance for coupling to the tuned circuit. Of course this brings up the problem of minimum capacitance which is also increased by making this change.

Therefore, a compromise must be found. One way is to switch in separate coupling capacitances for a wider range to get away from the non-linear portion of the curve. (Paralleling diodes to increase the tuning range brings up the same problem.) The answer is to use the MVP40-30 circuit that is very linear over almost all of its range.

So the MVP40-30 looked pretty good but how about the tempco effect? As with the MV104, there was a difference between the high end and the low end. The low end showed no change from 68 deg F to 93 deg.(50Hz on the MV104) But the high end showed a negative 83 Hz/F. The frequency went down with increasing temperature. The MV104 was 125Hz per degree F. A definite reduction in the temperature effect is seen. A sample was made of an additional two pairs of diodes with similar results.

In any event, the 1N4005s showed promise over the MV104 and are easy to find and very inexpensive. (\$.10) I didn't try any other 1N400X diodes since these were the only ones I had. The other series should do equally as well. I also tried 1N914s for fun but they showed no change in frequency with varying voltage. I also had an NTE618 which is similar to an MVAM109. I ran a linearity check on this element and found it was not too bad over the 4.0 range. The MVAM109 was not quite as good. (See Figure 3)

The final configuration of the oscillator, using polystyrene capacitors in the other controlling parts of the circuit, resulted in a tempco of less than 100 Hz/deg F being positive at one end and negative at the other, giving some intermediate point at zero tempco. Of course this may not be

FIGURE 3

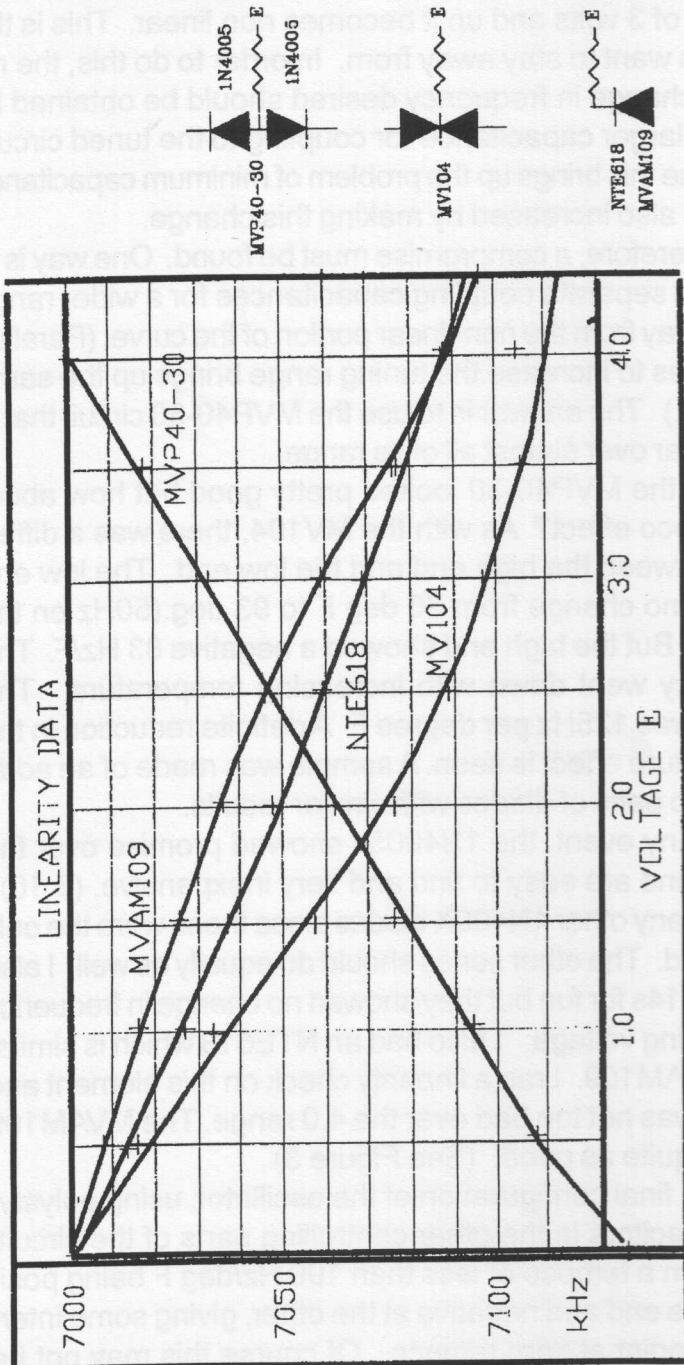

reproducible in every circuit of this kind, but it goes without saying that the tempco will probably be much more, if certain precautions are not taken. There are, no doubt, cancellations taking effect that produced this low value and they can't always be counted on. I did note that the poly caps tend to cancel out the tempco of the toroids. If the tuning device is one of low tempco then the resulting overall tempco should be smaller. The active device also contributes to the change and the HC04 hex inverter has some effect causing the frequency to rise with increase in tempco but it isn't as sensitive as other elements.

Next, I removed two of the polystyrene capacitors on the input (C1 and C2) and replaced them with COG capacitors which are essentially NPO type capacitors around room temperature. The end result was the tempco for the original full circuit of less than 100Hz went to greater than a positive 200Hz/F. Thus it can be seen that the negative tempco of the poly caps did some reduction of the tempco. Combination of the NPO and poly caps in parallel could be used to further reduce the tempco.

OSCILLATOR INFORMATION

The waveform at the output of this oscillator is a square wave which is useful in driving a balanced mixer. A sine wave is also available using an isolator stage connected to the pin 1 of the 74HC04. This output can be used to drive an output stage of a transmitter with proper buffering. I found that the 74HC04 with a buffered output gave much better results as compared to non-buffered units. They are designated with a suffix of B1. For some reason the unbuffered units seemed to drift endlessly. (Use the type indicated in the parts list)

TURN ON TIME DRIFT

The turn on time (turning on the circuit from a cold start and observing the frequency shift as a function of time) of

FIGURE 4
TURN ON DRIFT
MVP40-30

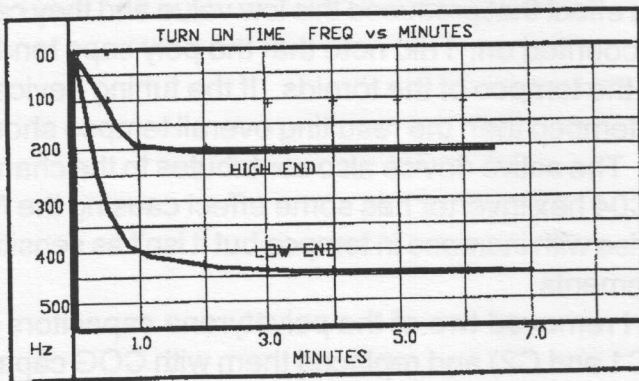

MV104

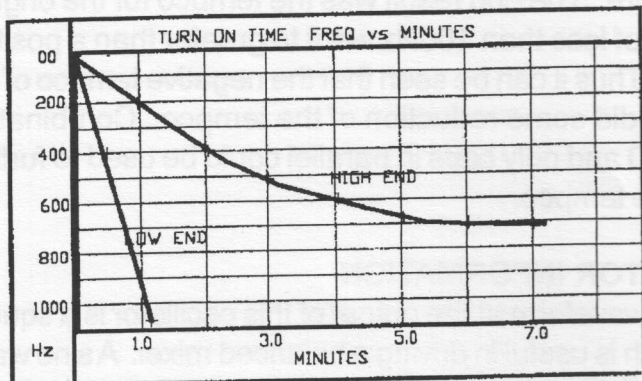

NTE618

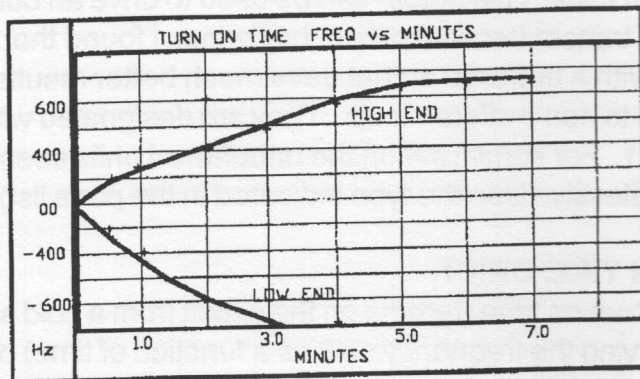

the oscillator was affected by the voltage level supplying the HC04. To keep the output voltage high and at the same keep the turn-on time small, the best voltage was about 4.5 volts. Figure 4 shows the difference in turn-on time for the MVP40-30 vs the MV104 in this oscillator circuit. The MV104 shows the problem I found that resulted in developing the new circuit, the change in frequency with a step input signal.

CONCLUSION

To keep the temperature effect low using analog devices is a cut and try proposition. It can be done if you have the time to experiment with various components. I found using an oven speeds up the process. I earlier used the temperature differential between evening and the next morning, but that was very slow. Also, using a blow pipe on various elements can be used to locate the most sensitive unit. By blowing thru the tube you can concentrate on each individual part and determine if the frequency changes in an up or down fashion. Of course, it is best to have a frequency counter to make these tests but listening for the oscillator in another receiver can be helpful.

Capacitor C3 can be changed to obtain greater band change or R1 can be used in the same fashion. Reducing R1 decreases the bandwidth change and visa versa.

TEMPERATURE ADJUSTMENTS

To fine tune the tempco, first determine the direction of frequency change as a result of a temperature change at both ends of the band. If the direction of change is such that the frequency goes up with an increase of temperature at both ends, then the polystyrene capacitors provides too much compensation. (Of course, the reverse is true if insufficient compensation is used). Reduce the value of one of the poly caps and in parallel with it connect a NPO or COG cap to give the same value as the original poly cap. The final result should

give a positive tempco at one end of the band and a negative tempco at the other end resulting in a zero tempco somewhere in the middle of the band.

FINAL NOTE

After making the above tests, I decided to go back and check the tempcos. I found that I had no longer achieved less than 100 Hz per deg F, but 142Hz on the low end and 44Hz on the high end. Both showing that the frequency rose with increase temperature. This indicated that I had too much compensation from the polystyrene capacitors. This was the same circuit that I originally started out with. So why the difference? The only difference was the toroid coil which had undergone a boiling. So I wound another coil and replaced the boiled unit. Then end result was 33Hz on the low end and 12Hz on the high with one going up and the other going down. Thus, somewhere in the band the tempco was zero. If you recall, I mentioned that the tempco of the toroid went negative after boiling. This is the same tempco of the polystyrene capacitors. So they were not canceling out each other as in the original configuration.

So my final conclusion is, in this circuit or any other where you are using polystyrene capacitors, do not boil the coils if you want to use their tempcos to cancel each other.

VARICAP ADVANTAGES

One nice thing about using varicaps as tuners is their small size and mechanical strength compared to the air tuning capacitor. Air tuning capacitors are now very scarce and, if available, are expensive. Since the varicaps are controlled by a variable voltage, one can use a multi turn pot to achieve band spread tuning. Where as the air caps require a mechanical reduction gear arrangement. (Very expensive)

The disadvantages of the available Vericaps were 1. They were temperature sensitive 2. Their change in frequency

in response to a linear voltage change was very poor and 3. The range of capacitance change was limited. I believe the MVP40-30 will overcome these problems and hopefully not introduce any new ones.

I wish to express my thanks to John Pratt (N1UA) for his help and thoughts and acting as a sounding board for my ideas. He has checked out my designs and made valuable suggestions for improving them. In addition, to Dave Meacham (W6EMD) for his perusal of the article and helpful suggestions.

REFERENCES

1. Oscillator Designs with Varicaps, QRPp Vol III , Number3, Sept.1995
 2. Pending article, by the author, on a Transceiver called the P40-30 that uses this oscillator.
 3. QRP CLASSICS "The Fine Art of Improvisation" page 108
 4. QRP CLASSICS " Tuning-Diode Application " Page 112
- 72 Jim Pepper W6QIF@i.x.netcom.com

PARTS LIST

Toroid T50-6	DC Electronics
1N4005	DC Electronics Mouser 583-1N4005
1K pot	DC Electronics 31VA301 Mouser "
39pF COG cap	DC Electronics 110COG390J50V Mouser 80-C315390J1G
LM317T	DC Electronics Mouser 512LM317T
Polystyrene caps	
470pF	Mouser 23PS147
Hex Inverter/Buffered	Mouser 511-M74HC04 74HC04B1

Note: All of the above parts can be obtained from Mouser except the T50-6.

MOUSER ELECTRONICS 1000 N Main Street, Mansfield
Tx 76065-1514
1-800-346-6873
DC ELECTRONICS PO Box 3203 Scottsdale Az 85271-
3203
1-800-467-7736

The QRP Improv Antenna

by

Joe Everhart, N2CX

This article came about because of the frustrations I've encountered trying to operate a ham rig while on business travel. It's not an uncommon situation for business travelers and others who want to make the best use of their time in rented rooms.

Now I've tried a variety of ways of dealing with the problems encountered. I've come to the conclusion that operating an HF rig with a skywire inside such a room is almost useless. Most places have metallic skeletons or outer skins which drastically attenuate RF energy (a waveguide beyond cutoff is often used, in fact, as an intentional attenuator!) And reception is hampered by a cacophony of AC line noise TV horizontal oscillator spectral picket fences and assorted digital hash.

Occasionally I'm lucky enough to find a window that opens and even more rarely an outside balcony on which to set up an antenna. But that's not too often - at least on those occasions when I lug along a travel rig. Now I hate to carry along too much so whatever I carry along has to be extremely small and light to fit inside my luggage in an almost negligible space.

I've decided that the best overall guarantee of success is to count on operating from outside the room. Given good weather and ham friendly public parks a lightweight dipole

(perhaps a Gusher!) works well.

But more often than not, the weather sucks and there are no nearby parks.

I try to arrange a rental car whenever I have to stay more than a couple of days in one location so my plans now revolve around it. The car is a handy source of 12-volt power for a QRP rig, it offers a relatively comfortable operating position out of the weather, and it presents a reasonable ground plane for antennas.

Several options are presented in Reference 1, but for now I will concentrate on a compact, simple single-band monopole antenna.

Since it was the result of some judicious on the road parts acquisitions and was literally thrown together rather than carefully designed, I call it the Improv Antenna.

The idea is quite simple. It consists of a quarter wave wire monopole that uses an auto body (or other suitable conductive structure) to supply an RF ground. The key to its performance is having an effective ground plane. An auto's body is on the order of a quarter wavelength or so on 20 meters giving it a low loss resistance. And it's not too bad on 30 and 40 meters.

The quarter wavelength is a tradeoff among several factors:

1. It is resonant and gives a reasonable match to 50-ohm feedline without the need for a tuner or SWR bridge.
2. It should have better efficiency than a loaded whip due to its increased radiation resistance and not needing a lossy inductor.
3. A quarter wave wire for 20 meters is only a tad over 16 feet so it fits nicely in a suitcase. The whole shebang with connectors and a 25-foot length of coax feedline displaces only an extra pair of socks or shorts. A 40 meter wire is only marginally more bulky.
4. Small-gauge hookup wire can be set up quite stealthily if

suitable supports can be found.

5. The antenna is inherently good for only a single band but that's not much of a handicap for casual operation. Actually a $\frac{1}{4}$ wave wire for 40 meters can be used on 20 and 15 as will be shown later.

6. Hookup wire is expendable if need be and can be gotten almost anywhere if it has to be replaced.

Figure 1 shows the almost trivial schematic diagram. The antenna section, a quarter wave wire and ground are connected to a 50-ohm feedline.

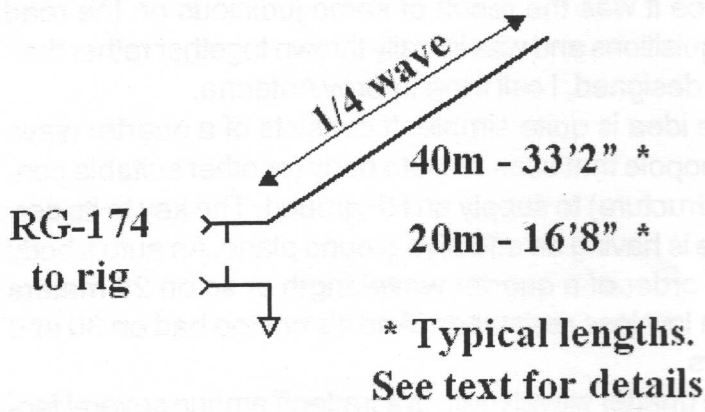

Figure 1 - Improv schematic diagram

Figure 2 shows the base connector I use. Since the antenna is made of light-gauge wire and is only for temporary setups, there is no need for excessive strength. A common 5-way binding post is soldered to the center pin of a chassis-mount BNC connector. One concession to strength is that I slipped a short length of brass tubing over the solder joint before soldering so that it would not be unduly stressed. The stripped end of the wire radiator slips into the binding post hole for mechanical and electrical connection. The antenna's

ground connection is via a 6-inch length of hookup wire soldered to a lug on the BNC connector and terminated in a large alligator clip. 20-ga. stranded wire is best for longevity. A shorter lead would often work but use 6 inches since sometimes length matters.

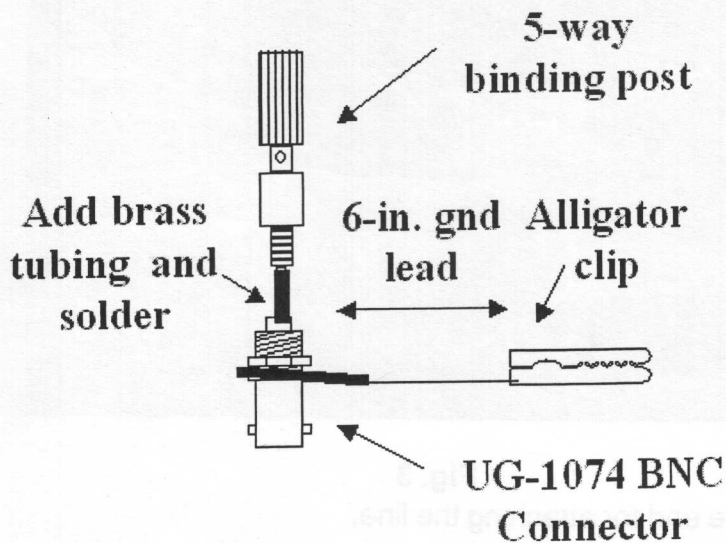

Figure 2 - Improv Base Connector

A complete parts list appears below.

Figure 3 is a photo of the Improv that I carry with me. Everything shown fits easily inside a plastic zipper bag. I have found the bag a necessity so that nothing is left behind and so that the wire doesn't end up twisting around clothes when airport baggage handlers sling my suitcase around. And these days, who would want a suspicious security bag finding loose wires and electronic parts during a luggage search?

The photo also shows tubular insulators on my wire. They are not really necessary to insulate the wire from the support lines unless you plan to operate in we weather. Just tie a knot

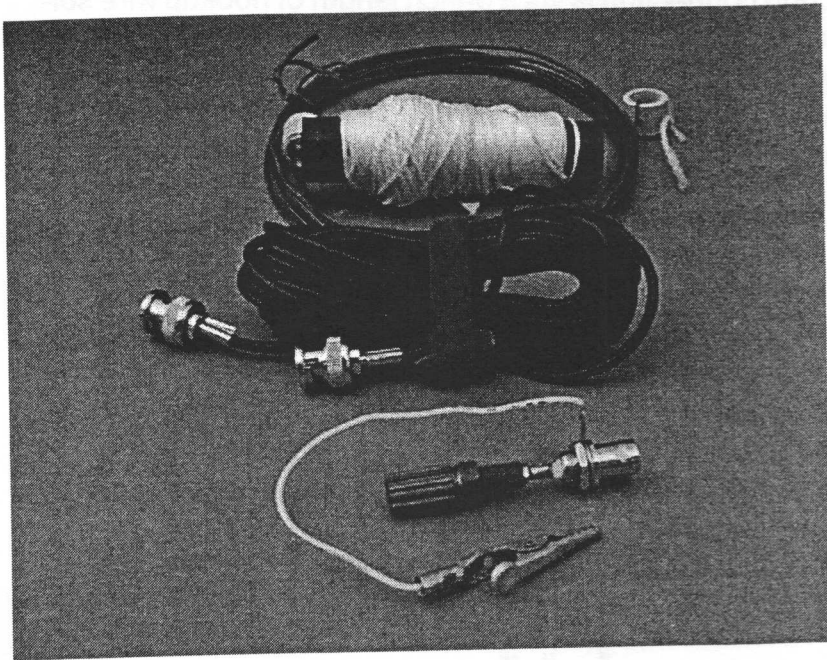

Fig. 3

in the wire end for attaching the line.

The ground lead needs to make a good low-resistance connection to a car chassis. Back in the "old" days of solid metal bumpers the easiest way of doing this was to clip right onto the front or rear bumper. But these days most sedans and minivans have plastic decorative bumpers backed by more collapsible plastic to absorb the force of a collision. In almost all cases I've been able to open a vehicle's trunk and find a metallic edge inside close to the trunk that will give a good solid electrical connection. Since this is inside the trunk it is not too damaging to scrap a little paint in an out of the way location. Just be sure to touch it up with some nail polish (yes' it's in the parts list) to ensure that it doesn't rust once you have returned the vehicle. Now some luggage and ski racks are electrically connected to the car body, but many are not. You can get an idea of whether or not that is true by

connecting up the Improv to a receiver and touching the ground lead to the candidate location. Received signals should rise dramatically if there is a good ground connection.

I generally use light-duty kite string for support the Improv. Besides being stealthy, cheap and strong enough, it is ultimately very expendable. My usual source is the same dollar store that supplies the nail polish usage described later.) Getting the support line up into a tree or over a light pole is easy. You know those little plastic bottles of hair conditioner in your hotel room? They are the right weight to tie on the end of the kite string and pitch over a convenient limb. Now you know why they give you shampoo and conditioner.

For best results the wire should rise vertically away from the ground plane. The signal will be vertically polarized and suffer minimum loss from its surroundings. Figure 4 illustrates the ideal condition.

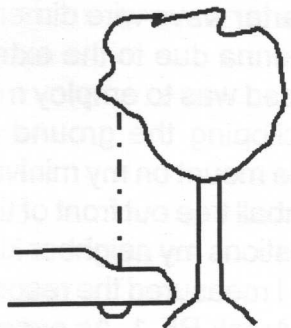

Figure 4 - Vertical Improv

More often I can't park my car directly under a non-conductive support but can find a nearby light pole or, better yet, a tree. The antenna works fine as a sloper as long as it is no more than 45 degrees or so from vertical as in Figure 5.

If you can find only short supports, lash the antenna up

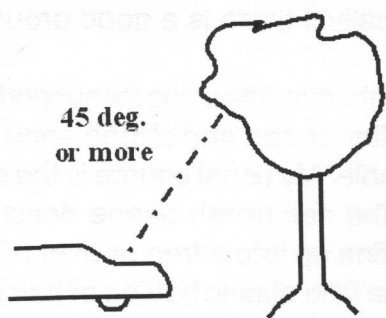

Figure 5 - Sloping Improv

as an inverted L. Try to keep the vertical portion as long as you can, but even if it's only 6 feet, that's better than a 6 foot mobile whip since the horizontal section of the wire acts as an almost loss-less top loading capacitance. And on 40 meters, it adds some high-angle radiation for close in QSO's.

The calculated quarter wave wire dimensions need to be tailored for each antenna due to the extra long ground lead. The procedure I used was to employ my personal vehicle as a ground by clipping the ground lead onto the grounded part of a mobile mount on my minivan and launching the wire over a buttonball tree out front of the house. After answering the usual questions my neighbor kids asked (they generally ask only once) I measured the resonant frequency of the antenna with my Autek RF-1. As expected the resonance was lowered due to the long ground connection. Then rather than cutting the wire short, I simply twisted it back on itself, a couple inches at a time until the resonance was raised to where I wanted it. See Figure 6. Tight capacitive coupling between the main wire and the twisted back portion effectively "short out" the overlapped length effectively shortening it electrically without having to cut any wire off. I've found that once the wire is resonated, no further adjustments are needed

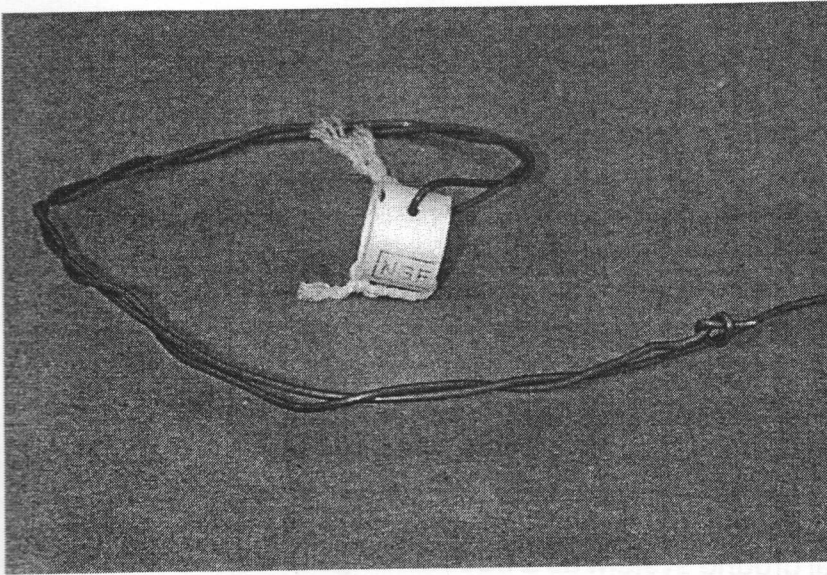

Fig. 6

in the field.

A "trick" can be used to employ a 40-meter quarter wave wire on multiple bands. The wire is used full length on 40 as a quarter wave. On 15 meters it is close to three quarter wavelengths long so it can be used as-is with slightly elevated SWR. On 20 meters, simply strip both ends of the wire and fold the wire back on itself, connecting both ends to the 5-way binding post. Connect the far end of the effectively halved length of wire (Fig 7) to the support line and you are in busi-

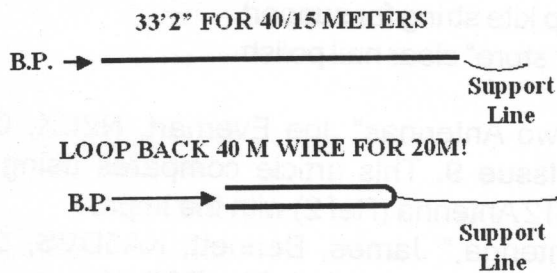

Figure 7 - Three bands from a 40-meter 1/4 wave wire

ness. However you may have to adjust the length slightly to get correct resonance on 20.

While I use the Improv for portable use in conjunction with an auto body, any decent ground can be used. For example if I were lucky enough to have a hotel room with a window that opened and it had a large metal frame, I could use the wire horizontally out the window to a nearby tree, using the window frame as a ground. Similarly an accessible metal balcony or rain gutter could be pressed into service. You could even use unconventional grounds such as chain link fences or metal highway guardrails so long as you could run the radiator to a suitable support. And going full circle to common portable antennas, the Improv can be used with a familiar radial ground system as a freestanding vertical. Gee, does that sound suspiciously like Dave Gauding's fishing pole verticals? Full circle indeed!

Improv Parts list

- 5-way binding post
- BNC chassis mount female connector
- 6- inch length of 20 Ga. stranded insulated hookup wire
- 1 - large alligator clip
- Optional brass tubing used to mechanically beef up solder connection to BNC center conductor
- ¼ wave length of wire (16' 8" for 20 meters, 33' 2" for 40/15 meters)
- Length of cheap kite string for support
- Optional "dollar store" clear nail polish

References:

- 1 "A Tale of Two Antennas" Joe Everhart, N2CX, QRP Homebrewer, Issue 9. This article compares using the KA5DVS PAC-12 Antenna (Ref 2) with the Improv
2. "PAC-12 Antenna," James, Bennett, KA5DVS, QRP Homebrewer, Issue 8, April, 2002. The PAC-12 is a small, very lightweight homebrew portable antenna.

The NorCal Web Page

NorCal maintains a web page that has many late breaking announcements of interest to QRPers. Our web master is Jerry Parker, WA6OWR. Please check the web page at:

www.norcalqrp.com

Subscription problems?

Paul Maciel, AK1P maintains the NorCal Database. If you have a question concerning your subscription please contact Paul at: ak1p@earthlink.net or by mail at:

PAUL A MACIEL
1749 HUDSON DR
SAN JOSE CA 95124

QRPP Subscriptions

QRPP is printed 4 times per year with Spring, Summer, Fall and Winter issues. The cost of subscriptions is as follows:

US and Canadian addresses: \$15 per year, issues sent first class mail. All DX subscriptions are \$20 per year, issues sent via air mail. To subscribe send your check or money order made out to Jim Cates, Not NorCal to:

Jim Cates
3241 Eastwood Rd.
Sacramento, CA 95821

US Funds only. Subscriptions will start with the first available issue and will not be taken for more than 2 years at a time. Membership in NorCal is free. The subscription fee is only for the journal QRPP. Note that all articles in QRPP are copyrighted and may not be reprinted in any form without permission of the author. Permission is granted for non-profit club publications of a non commercial nature to reprint articles as long as the author and QRPP are given proper credit. Journals that accept paid advertising, including club journals, must get prior permission from KI6DS before reprinting any article or part of an article. The articles have not been tested and no guarantee of success is implied. If you build circuits from QRPP, you should use safe practices and know that you assume all risks.

**QRPP, Journal of the NorCal QRP Club
862 Frank Ave.
Dos Palos, CA 93620**

**First Class Mail
U.S. Postage
Paid
Mailed from Zip Code
93620
Permit #72**

First Class Mail

Volume X No. 3

Fall 2002

QRPp

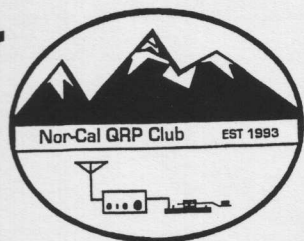

Fall
2002

Journal of the Northern California QRP Club

Table of Contents

From the Editor

by Doug Hendricks . . . 2

A Robust Rock-Mite Rendition

By Jerry Henshaw . . . 3

80 Meter Alligator

A Non-Rigorous Approach to Antenna Design

by Dave Redfern, N4ELM . . . 11

NB6M 10 A Homebrew 10 Meter Transceiver

by Wayne McFee, NB6M . . . 17

The NorCal 30 Presentation at Pacificon

by Doug Hendricks . . . 42

QRP Operating

By Richard Fisher, KI6SN . . . 57

From the Editor

by Doug Hendricks, KI6DS

You will have noticed that you received two issues of QRPp in one mailing. I had fallen so far behind, that it was necessary to do two issues and mail them at the same time. A few of you had your subs expire with the Summer issue, you got a bonus for being so patient. Thank you for your patience and understanding. For the first time since my bypass 3 years ago, I am caught up with things. Now to do some operating and enjoy the coming basketball season. Please check your mailing label or the NorCal web page at www.norcalqrp.com for the status of your subscription. If you have run out with either this or the summer issue, please renew by sending in your money to Jim. Thanks for your support and participation in QRP. Next Spring will mark the 10th anniversary of NorCal. Help celebrate by operating, building and being involved in QRP. 72, Doug

A Robust Rock-Mite Rendition

By
Jerry Henshaw
KR5L

Construction

I saw a picture of Doug Hendrick's Rock-Mite on Rod's (N0RC) web site and was inspired to build my version of the rig. I will be the first to admit that I have violated the spirit and letter of Dave Benson's goal of a simple one evening project that could easily fit into the proverbial Altoids tin. I decided to see how much electronics I could stuff into a nifty little enclosure I bought a Dayton several years ago. See Photos 1 and 2. The box is still available at Mendelson's Electronics (MECI part number 160-0181) for \$4.95 plus shipping, etc. I like the removable metal side rails that can accept a PC board. I used

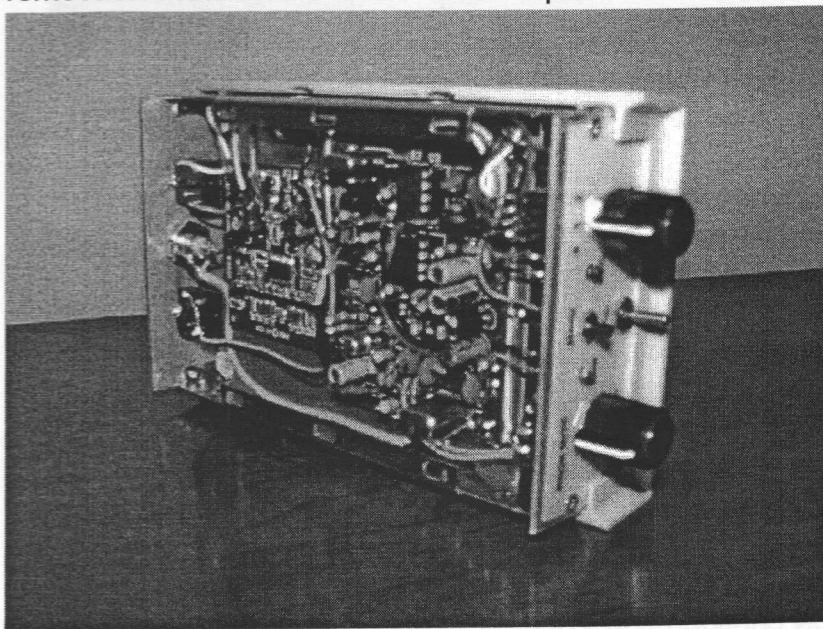

Photo 1

a two-story approach to housing all the goodies in this little enclosure. Below is an inventory of the modules contained in

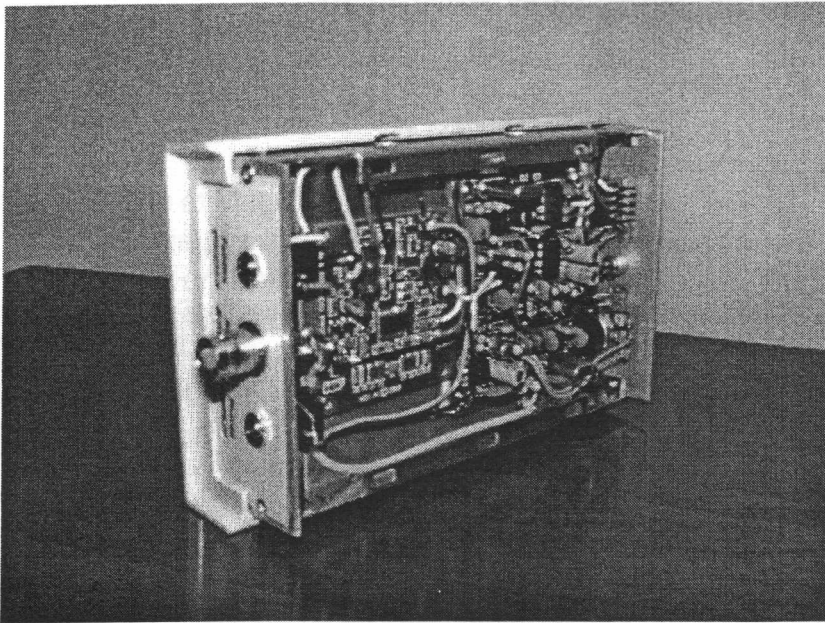

Photo 2

the box:

- Rock-Mite 40 meter transceiver
- Steve Weber's AAPB Audio Filter
- Embedded Research EPS-1 DC to DC converter (12 volts out)
- 4 AA Battery holder (6 volts input to the EPS-1)

The bottom "story" contains the batteries and EPS-1 converter. I cut a slot in the bottom of the enclosure to allow easy access to the 4 AA batteries. I used a discarded PC card slot blank for the metal strap to secure the battery holder (a 4-40 hex nut epoxied on the inside of the case holds everything together). See Photos 3 and 4 for a close-up of power supply configuration. I bought the EPS-1 DC to DC converter at Dayton several years ago when they first came out. I have been waiting for just the right project to put it to permanent use — the Rock-Mite was that project. The nifty thing about

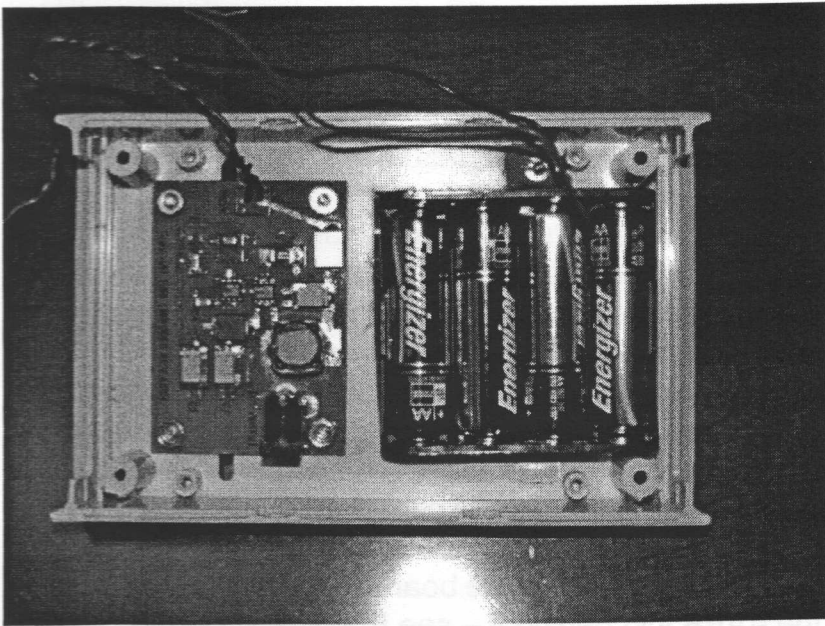

Photo 3

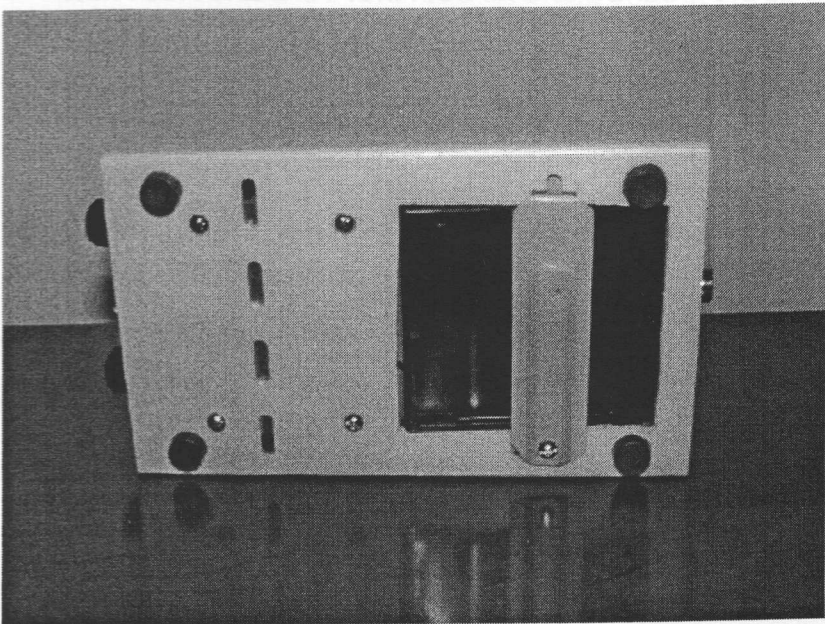

Photo 4

the EPS-1 is in can operate down to 2 volts input and still put out 12 volts. You can still get a lot of useful life out of weaker batteries by using the EPS-1. The current limit of the EPS-1 is about 500ma – more than adequate for the little Rock-Mite and AAPB filter unit.

I used a piece of PC board material out of my junk box (probably came from Radio Shack) as the foundation for the second story of the unit. The PC board slides into slots on the side rails of the enclosure. The PC board provides both a mounting surface as well as a ground plane and shield for the rig. I wanted to make sure the EPS-1 wouldn't generate noise in such tight quarters. The PC board provides a good RF shield as well. It works well, I can't detect any digital noise whatsoever in the rig.

I mounted the Rock-Mite board toward the front panel and the AAPB just behind it – see Photo 5. I used the PC board as the ground plane for both the AAPB and Rock-Mite

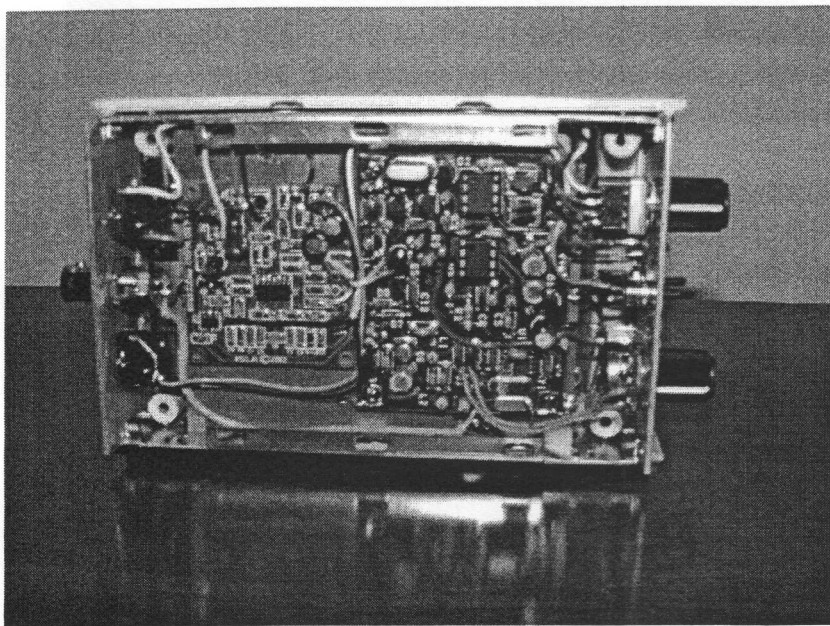

Photo 5

units. The large ground plane makes an effective low impedance ground return for the unit. This large ground plane gives some of the same benefits (low noise, etc) as Manhattan construction.

I made a couple of mods to the Rock-Mite board. I increased the value of R1 and R8 to 1K to reduce the zener bias current with a 12-volt power input. The original resistor values were chosen for 9 volt operation. I added a "Shift" LED to let me know when the frequency of the Rock-Mite was shifted. This mod required placing an LED in series with the zener D5. I reduced the value of D5 to 5.6V (originally 7.5V) and carefully measured the forward voltage drop of several of my junk box LEDs until I found one with a 1.8 volt drop. The series combination of my new D5 5.6 V and my "Shift" Led 1.8 V equals 7.4 Volts which is close enough to the original 7.5V that Dave Benson specified. Thus the amount of frequency shift is the same as the original design. I highly recommend the shift LED mod as it is difficult to know which of the two operating frequencies you are on without it. I made a custom heat sink for the final transistor out of a tin can – I cut a ¼ inch wide strip of tin, folded it in half, and wrapped it around a drill bit of the same diameter of the 2N2222 and formed a little heat sink.

I used my "Modified Doofus" SMD hold down jig with a "ticky-tack" glob on the end to hold the SMD parts in place while building the AAPB. The little jig worked great. I used two lead weights which proved to be just the right amount of holding power. A picture and description of this tool can be found on the NORCAL website under SMD Hold Down Jigs. I also used a toothpick with a little dab of "ticky-tack" to pick up and place the SMDs on the pc board. I find this method far superior to using tweezers that have a tendency to launch SMD parts into never-never land. Steve called for some black rubber sealer to enclose the ends of the heat shrink "light tube" that houses the green LED and photo resistor. I used

some black model airplane enamel that I had laying around the house to seal the ends – worked just fine and saved a trip to the store.

The front panel has the following: (See Photo 6)

- AF Gain (Volume)
- AF Filter Select
- Power
- Menu
- Shift LED
- ALC LED

The rear panel has the following: (See Photo 7)

- BNC RF Output
- Paddles
- Phones

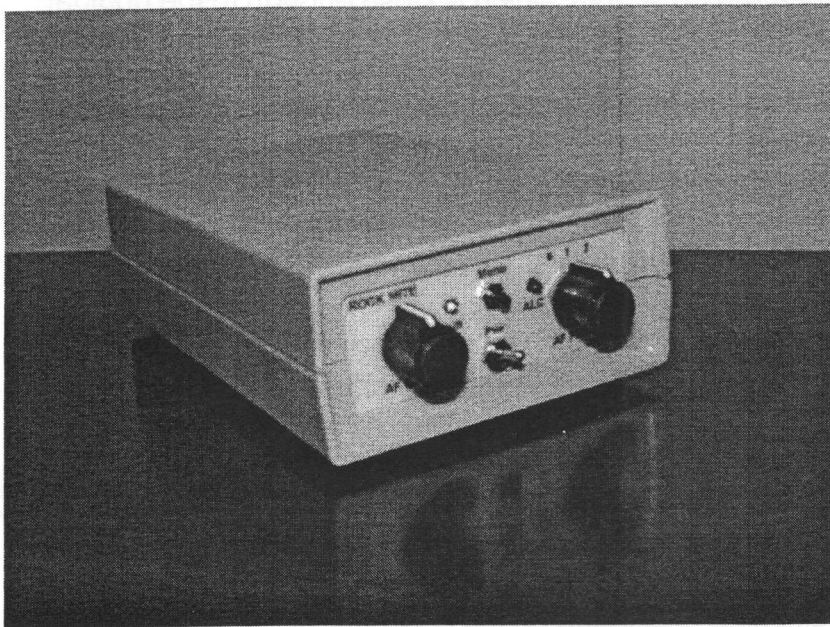

Photo 6

I had a problem finding a suitable volume control pot and three position rotary switch in my junk box or at Radio Shack. The space behind the front panel is really cramped. I

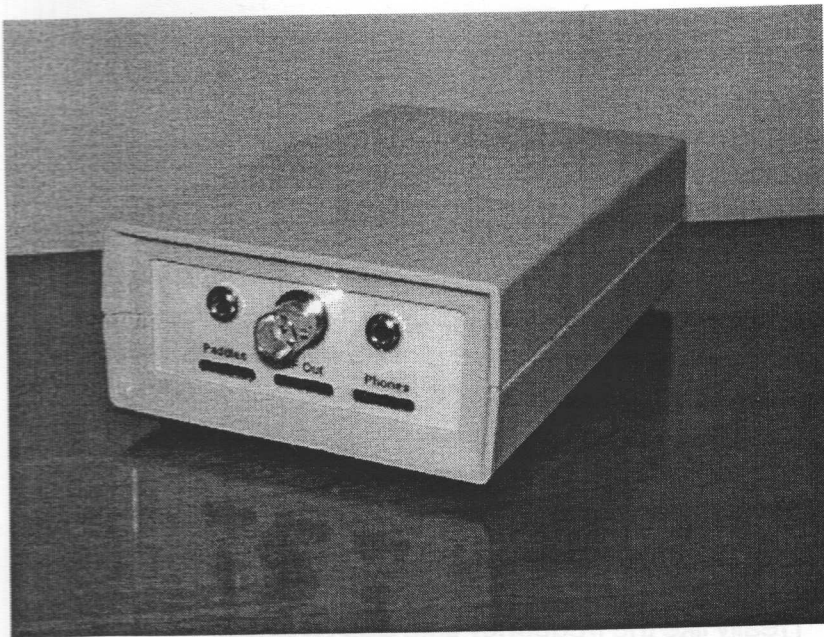

Photo 7

ordered a miniature 100K pot from Mouser (313-4000-100K) for \$1.94. MECI had a 2 pole 3 position rotary switch in their catalog (540-6316) for \$.95. These are miniature controls that fit the box perfectly. The audio taper pot from Mouser has 11 detent positions which give a good tactile feel to the volume control. The remaining panel mount parts came from Radio Shack or my junk box.

My word processor was used to generate the lettering for the front and rear panels. I used light gray card stock and my laser printer to make the panel overlays. I secured the overlays to the metal panels with clear packing tape. The tape provides a protective film for the printed overlays.

Operation

The objective of this project was to have a self-contained rig that requires only a resonant antenna, paddles, and headphones to get on the air. The rig meets the criteria.

The EPS-1 power converter works great in this appli-

cation. It generates no digital hash and provides a solid 12 volt output to the rig. My Rock-Mite puts out 500mw with the 12 volt supply voltage.

The AAPB filter is a MUST for this rig. Steve Weber really has a winner with this little filter. I used a 3 position rotary switch to select zero, one, or two filter stages. The filter provides a nearly constant audio output level and its action is indicated on the front panel ALC LED. This filter really cleans up the Rock-Mite square wave side tone. With the filter switched out of the audio chain, the sidetone sounds loud and rather harsh. With the filter in, the sidetone sounds clean and "smooth". I use the number 1 filter position most of the time and switch to number 2 when the QRM or noise is heavy. This filter removes the pops and strong signal ear splitting eruptions that we are all familiar with.

I really like the frequency shift LED. It serves as a power on indicator and gives you a visual indication of which operating frequency you are on. Without the indicator, you have to make a mental note of how many times you pushed the "Menu" button. I strongly suggest you add this mod to your Rock-Mite.

The Rock-Mite has a built-in keyer that is activated by pressing and holding the "Menu" button until a Morse S is heard. You increase the speed of the keyer hitting the "dit" side of your paddle and decrease the speed with the "dah" side – the defacto QRP standard method. Dave's keyer implementation allows the use of a straight key or external keyer by simply holding either the "dit" or "dah" side of the paddle during power up.

All in all, the Rock-Mite is a nifty little rig in and of itself. Dave's goal of a one-evening rig has been met in spades. The Rock-Mite is a huge improvement over its distant cousin the Norcal 49er (yes, I have one of those too!). I chose to take the Rock-Mite to the next level and I am very pleased with the results. If you are interested in finding out more information about the Rock-Mite, go to Rod Cerkoney's webpage

<http://www.radioactivehams.com/~n0rc/rm/>. Rod has compiled a complete list of links, pictures, mods, operating schedules, etc. on his awesome site – check it out.

See you on the air on or about 7.040 MHz.

80 Meter Alligator

A Non-Rigorous Approach to Antenna Design

by Dave Redfern, N4ELM

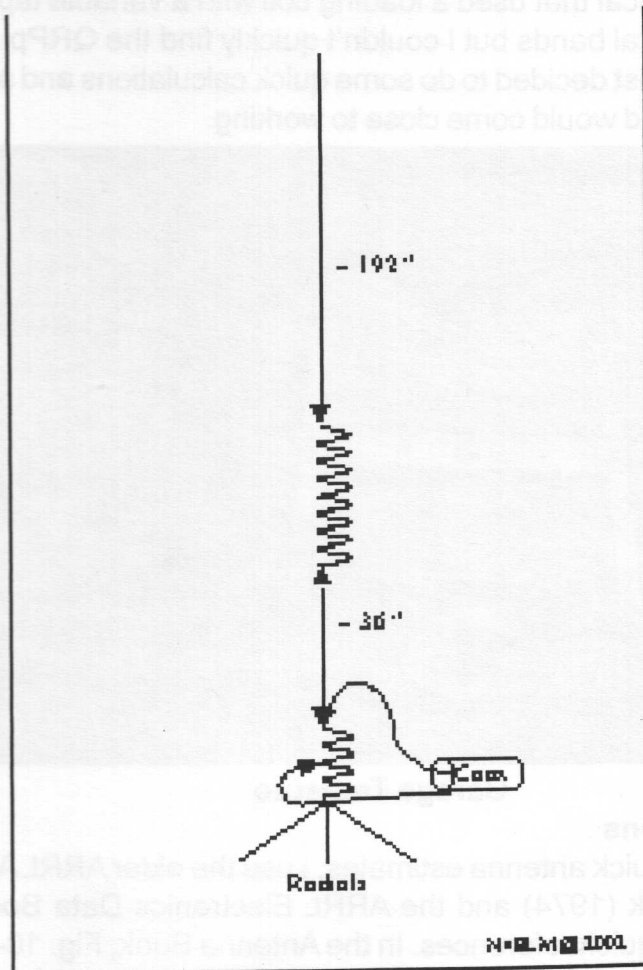

A few days before leaving for Arkiecon at the Ft Smith Hamfest, I decided to put together a temporary antenna to hopefully allow me to check into a Friday evening CW roundtable net on 80 meters near Dallas, TX. Based on previous experience at the Guesthouse Inn at Ft. Smith, I thought I would have better results if I could mount something on the car in the parking lot. Looking around the garage, I located a SD-20 telescopic fishing pole, lots of wire, alligator clips, and some B&W coil stock. I remembered a variation on the ST. Louis Vertical that used a loading coil with a variable tap to tune several bands but I couldn't quickly find the QRPP article, so I just decided to do some quick calculations and see if what I had would come close to working.

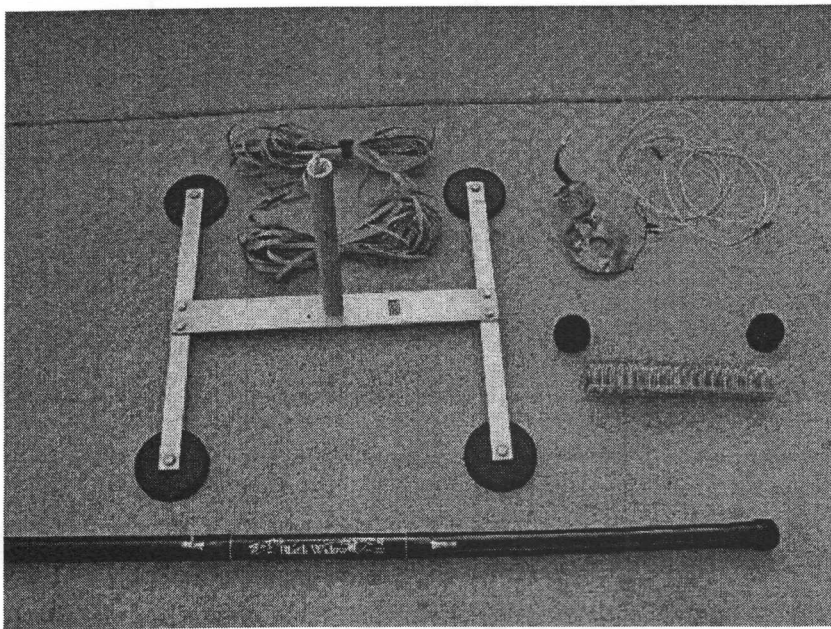

Garage Treasure

Calculations

For quick antenna estimates, I use the older ARRL Antenna Book (1974) and the ARRL Electronics Data Book (1976) as quick references. In the Antenna Book, Fig. 10-2,

is a chart to estimate the inductance values for an off-center loaded dipole. For my antenna, being a 1/4 wave, I just needed to calculate one side. To use the table you need to know: A – the percentage length of the shortened antenna (20 feet) to the full size antenna (66 feet) so $(20 / 66 = .3030$ or 30%) and B – the percentage of the distance of the coil from the feed point (3 feet) to the total antenna length (20 feet) so $(3 / 20 = .15$ or 15%). Plugging the values into the table gives an estimate of 1,600 ohms of inductive reactance (XL).

Using the reactance nomograph on page 27 of the Electronics Data Book with the frequency (3.55 Mhz) and XL reactance (1600 ohms) gives an approximate value of 70 uH for the loading coil which is a close fit for the larger B&W coil I had found.

For this antenna then: the operating frequency is 3.55 MHz, the total antenna length is 20 feet, the loading coil is about 1 foot long and located 3 feet from the feedpoint, and the length above the loading coil will be $(20 - 4 = 16$ feet). The loading coil is about 70 uH to load the 20 foot vertical to 3.5 MHz.

Because the antenna is very short at 3.55 MHz and the radiation resistance will be very low, I decided to use inductive shunt matching at the base to match the antenna feed point to the 50 ohm coax. I didn't calculate the shunt coil value, I just used a piece of coil stock that "looked big enough".

Construction

I used the B&W coil stock which was about 12 inches long, 2 inches in diameter @ 8 turns per inch as the loading coil. The shorter piece of coil stock, 2 inches long, 10 turns would be the shunt coil.

Mechanically, the loading coil is mounted above the first telescopic junction of the pole using two small pieces of foam pipe insulation for support.

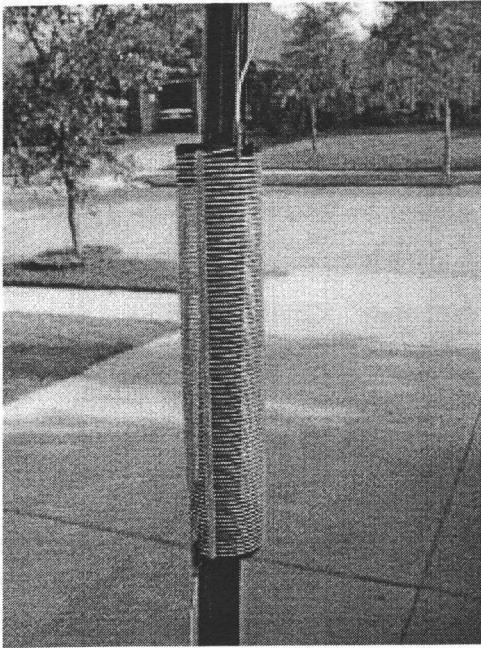

Coil

The 36 inch wire between the feedpoint and the bottom of the loading coil has small alligator clips on both ends to allow connection and tap onto the coil. The top of the antenna is a 196 inch (16 foot) wire supported from the tip of the pole with a small alligator clip on the bottom to connect to the top of the loading coil.

The base and feedpoint of the antenna is a circular copper PCB disk with a BNC connector for attaching the coax and several studs for attaching radials and other ground connections.

The shunt coil is about 7 or 8 turns connected between the BNC center pin and tapped to ground.

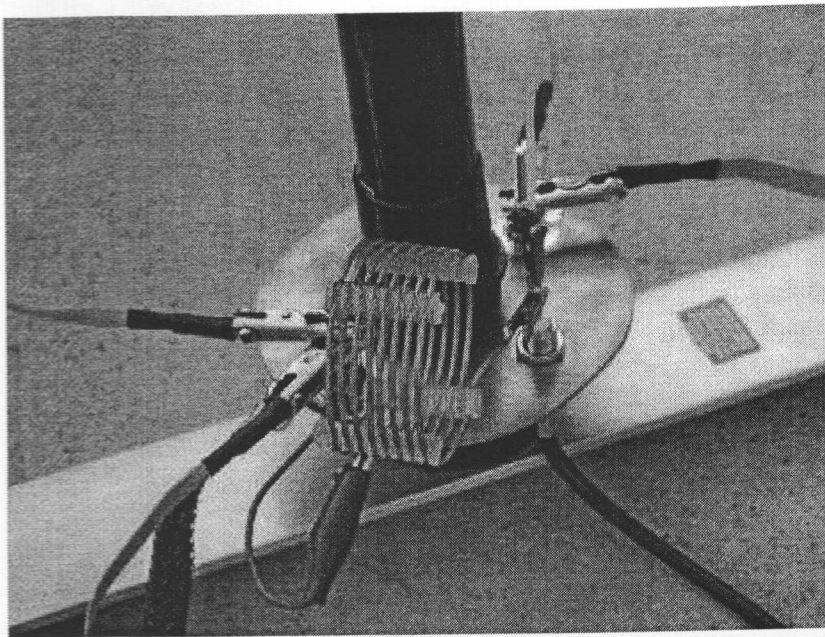

Antenna Base

The entire pole, antenna, and feedpoint assembly is supported by the large four magnet mount on top of the car. A 1/4 inch threaded rod secures a 12 inch long, 1 inch diameter fiberglass rod to the mag mount. The SD-20 slides over the rod and traps the feedpoint disk. While this is a sturdy mount and had no problems supporting the antenna, it would not be a good idea to try and drive down the highway with the SD-20 pole attached J

This is a quarter wave antenna, so some sort of counterpoise connection will be needed. After initial testing with the mag mount, I connected four St. Louis Radials to the studs on the ground disk. This provided more consistent tuning and a better match to the antenna.

Tuning

Initial tuning was performed using an MFJ-259 antenna analyzer with the antenna mounted on the car. I started with the maximum turns on the loading coil and the shunt inductor

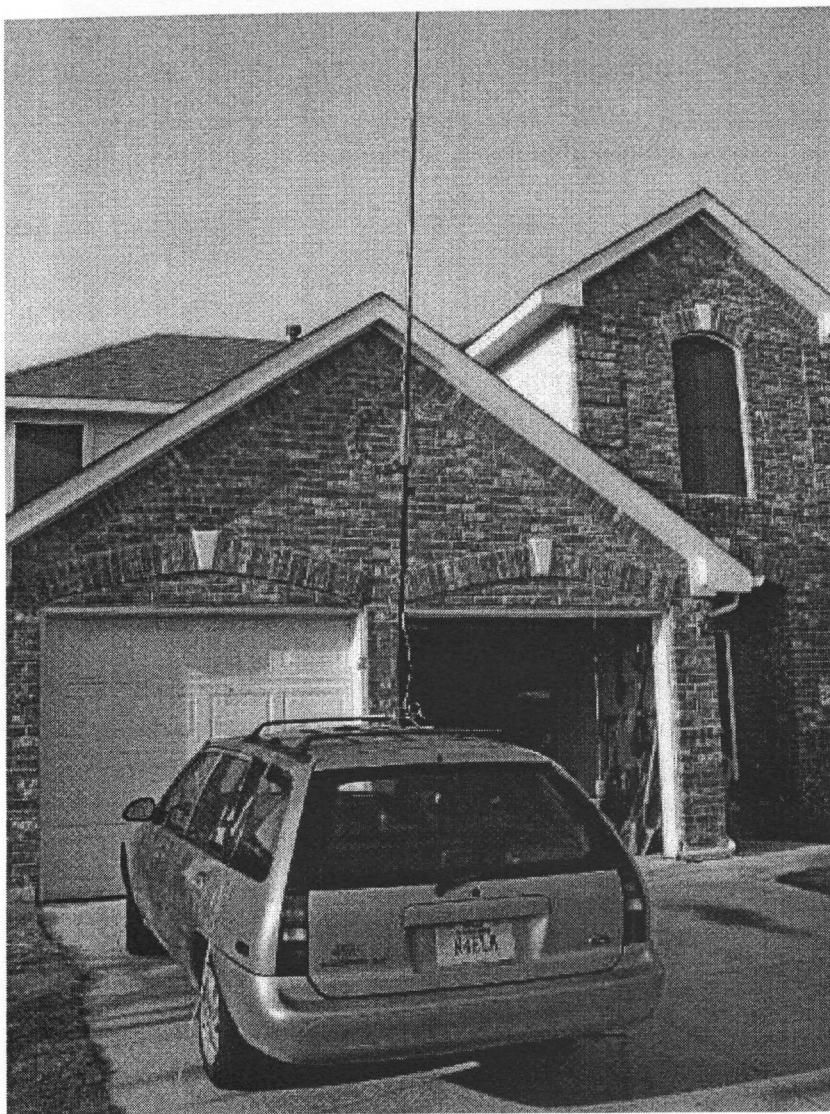

Yard Art

and radials disconnected.

I tapped down the coil until the minimum SWR dip shown by the analyzer occurred at 3550 KHz. The SWR dip coincided with the reactance dip which I took as a good sign.

Then I added the shunt inductor and adjusted its tap for

an SWR of 1:1 on the analyzer.

Adding the 4 radials shifted the resonance point down about 100 kHz, so the coil tap was moved to bring it back up to 3550 kHz.

I disconnected the analyzer and connected the FT-817 to the antenna through a cross needle SWR/wattmeter and the SWR dipped to 1:1 within a couple of kHz of the analyzer reading.

The 2:1 SWR bandwidth was very narrow, about 25 kHz, which seemed reasonable for a very short vertical.

Results

After dinner on Friday night, I parked in the corner of the Guesthouse parking lot and set up the antenna. With the FT-817 running about 4.5 watts I was able to check into the round table and worked 3 or 4 stations located between McKinney, Sherman, and Bonham Texas for about 45 minutes. Receive signals were reasonable and I got several favorable comments about my signal.

Dave Redfearn, N4ELM

NB6M 10 A Homebrew 10 Meter Transceiver

by Wayne McFee, NB6M

What started out as a simple VXO experiment has snowballed into the building of a complete 10 Meter QRP CW Transceiver. The rig tunes from 28.001 through 28.088 MHz, covering a good portion of the lower end of the band and including both the common DX frequencies and the 10 Meter QRP calling frequency.

A 14 MHz VXO, followed by a frequency doubler and a double-tuned bandpass filter, provides a stable 28 MHz signal source for the transmitter, and, with a frequency offset scheme utilizing RIT, acts as the direct conversion receiver's local oscillator as well.

Because of the inherent non-linearity of a wide-band

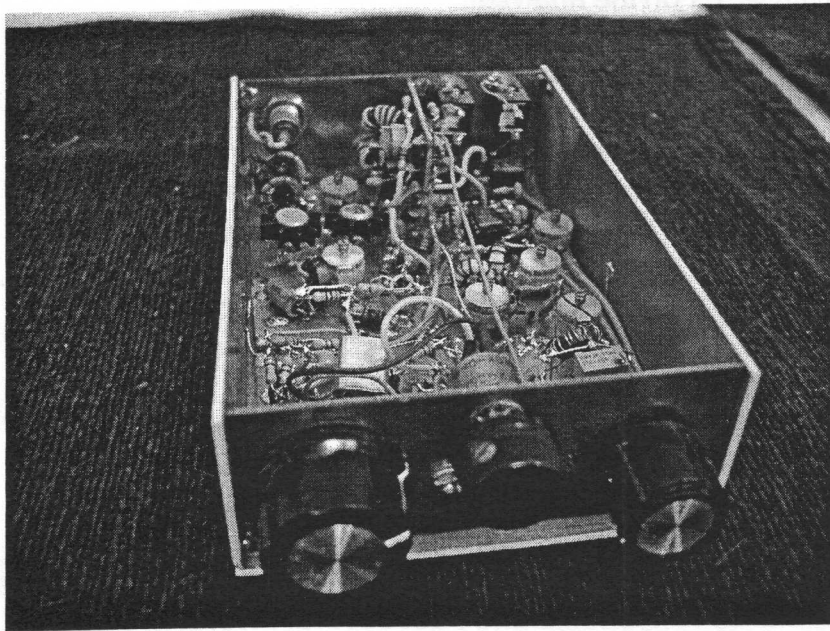

VXOs tuning, the RIT is not linear across the tuning range. However, the RIT circuit shifts the 28 MHz signal 1 KHz at the upper end of the VXOs' tuning range and about 2.7 KHz at the low end. In practice, this has proven to be sufficient, as it is easy to adjust the RIT knob for whichever received tone is preferred by first zero beating the received signal through the use of the "spot" switch and then adjusting the RIT as desired.

The transmitter puts out about 1.5 Watts, and the receiver, a simple direct conversion design lifted from Wes Hayward, W7ZOI's, updated Micro Mountaineer, is sensitive enough to hear all but the weakest of signals.

A Tick keyer was included, both to provide the keying function and to provide sidetone, which is introduced into the receiver's audio output.

I started out working with a simple crystal oscillator, using a common 2N2222 and a pair of 14.060 MHz crystals.

After a bit of experimentation, and switching from a pair of cheap silicon diodes to a 1SV149 tuning diode, the VXO tuned from 13.990 through 14.044 MHz. The addition of a resistor in the ground lead of the tuning pot, selected in value to set the lower end of the tuning range just above 14000.5 KHz, prevents out-of-band operation.

Obviously, the fundamental tuning range of this VXO would be quite useful on 20 Meters, as well, but since I had already built a push-push frequency doubler for another project, and had wanted to try QRP on the 10 Meter band, I chose to use the VXO as part of an all homebrew Ten Meter CW rig.

Although the peak of the sunspot cycle has passed, there are still sufficient band openings and enough activity to warrant putting the rig on 10 Meters, and on-the-air results have more than justified the small amount of work and low cost of building the rig. Since I keep a fairly extensively stocked "junk box" of parts, I had all the parts needed for the rig already on hand.

Once the RIT circuit was added to the VXO, the signal was routed to a JFET buffer amp and push-push frequency doubler, on to a driver stage utilizing the metal case 2N2222A, and then to a single-ended power amplifier using a cheap and readily available 2N3053.

However, there were a couple of drawbacks to overcome. First and foremost, the signal purity was not good. Too much of the fundamental was getting through the transmitter, no matter how carefully the push-push frequency doubler was balanced. And, although the three quarters of a watt a single 2N3053 produced is sufficient power output for many contacts on 10 Meters, the PA transistor was running too hot.

Adding a double-tuned bandpass filter between the frequency doubler and the driver stage cleaned up the signal nicely. Adding a second 2N3053 in parallel with the existing PA gave about a Watt and a half of power output and cool

running of the transistors.

With the transmitter basically finished, and having a 28 MHz local oscillator signal readily available, the addition of a Direct Conversion receiver to turn the rig into a complete transceiver was a natural. Having wanted to try out the simple receiver design by Wes Hayward, W7ZOI, published in his July 2000 QST article on an updated Micro Mountaineer, I welcomed the opportunity to couple that receiver with the finished transmitter.

In my conversion of an SMK-1 to 20 Meters, I had found that an RF preamp was a necessary addition if one were to reliably hear weak signals on that band, with the NE602 and LM386 in a configuration similar to the MRX40 receiver. Wes, W7ZOI, had reported in his article on the updated Micro Mountaineer that the simple NE602/LM386 receiver in his rig copied a .1 uV signal. This was the primary factor resulting in the choice of using his design in this rig for 10 Meters. If the addition of an RF Preamp for the receiver was unnecessary, the rig could be kept simpler.

The SA612 Mixer is still manufactured by Phillips, and the other parts and transistors used to build the rig are commonly and cheaply available. Many of the parts are available from your local Radio Shack store.

All resistors used are ¼ Watt. All the .1 bypass caps in the rig are monolithic. The .01s and .001s used were disk ceramic. NP0 caps were used in all the frequency determining parts of the rig, and Silver Micas were used in the transmitter's output filter. I have not included a parts list, but with each stage individually detailed, a parts list is easily made up as construction progresses, stage by stage.

THE CIRCUITS

The complete transceiver's circuit is divided into three parts, here, for easier viewing. The three sections are designated VXO and Doubler, Filter and Transmitter, Receiver and Keying.

NB6M 10

HomeBrew VXO es Doubler

Here is the circuit for the VXO, Buffer and Frequency Doubler:

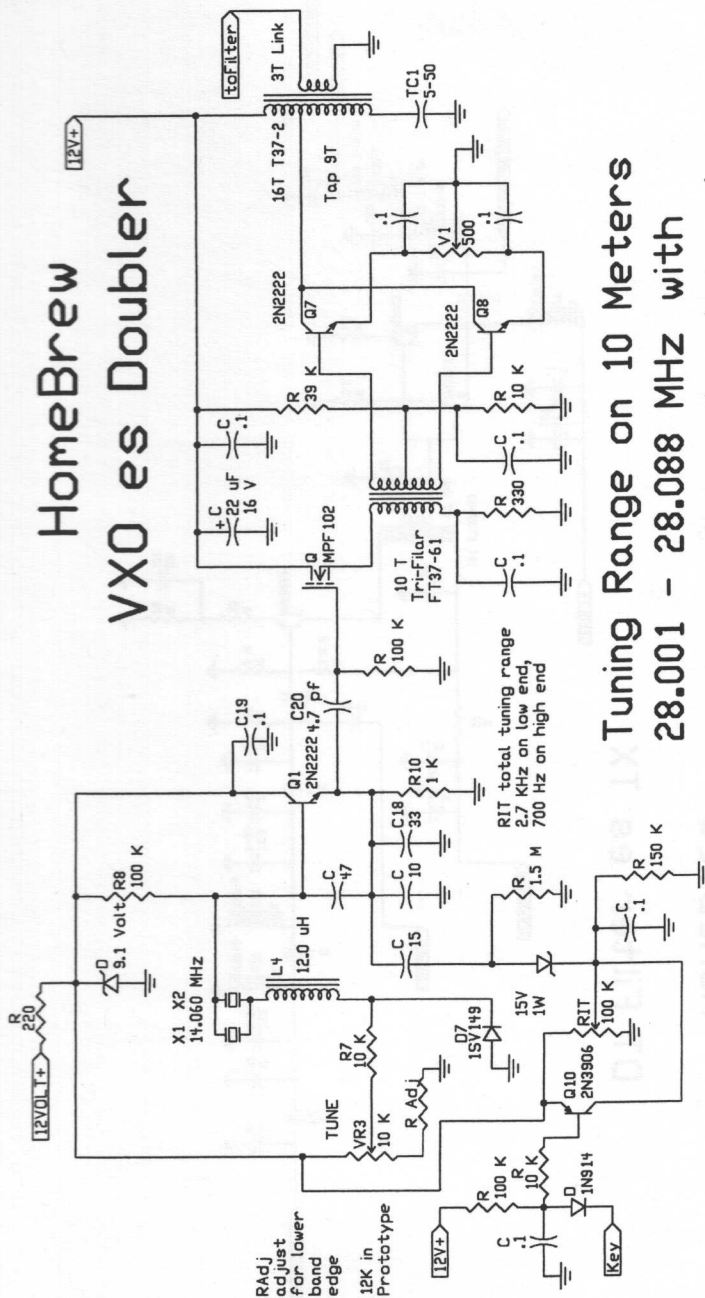

Tuning Range on 10 Meters
28.001 - 28.088 MHz with
components and values shown

NB6M 10

HomeBrew

DT Filter es TX

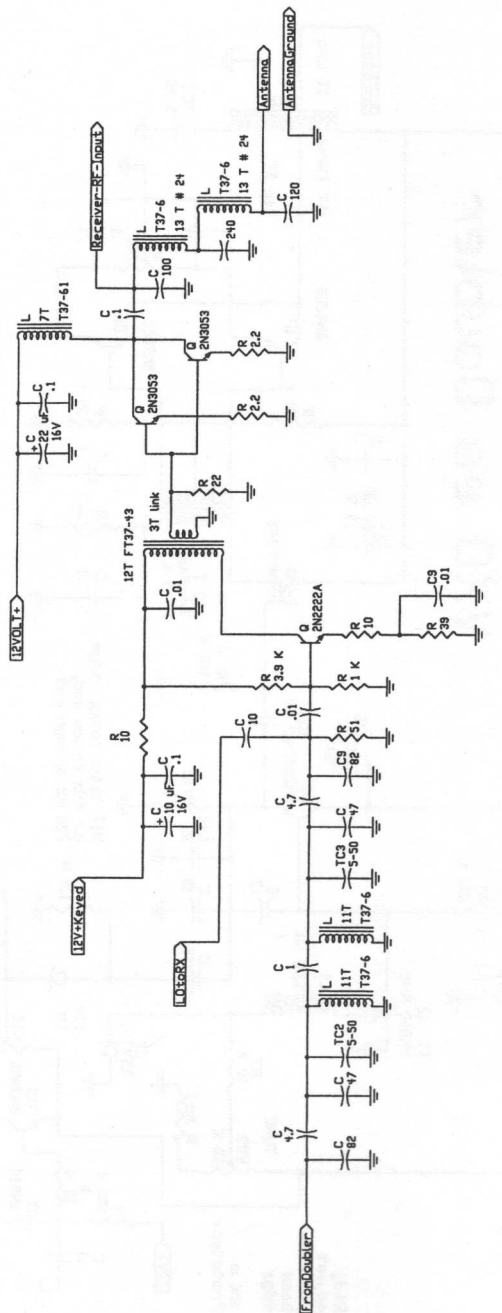

The Double-Tuned Bandpass Filter and Transmitter:

And finally the Receiver and Keying circuitry: Note this schematic is contained in the Insert Section in order to show it clearly.

BUILDING THE RIG

Except for the few Manhattan style pads glued down in order to mount a socket for the SA612 mixer IC, those few that are used to insulate contacts of the various trimmer capacitors, and a few in the Tick Keyer circuit, the entire remainder of the rig was easily and quickly built "Ugly" style, over the continuous copper ground plane of single sided PC board.

If you have not yet tried this method of building, let me just say that this is the easiest and fastest building method I have used. That, coupled with the fact that RF circuits built this way operate better and cleaner over that continuous copper ground plane than they do in a PC board, makes "Ugly" even better.

Sure, I know there is no PC board and photo layout to follow. You just start at the natural beginning of a circuit, in this case the VXO, start with a part that solders directly to ground, such as the 1 K resistor in the emitter lead of the VXO transistor, cut one lead, bend it at 90 degrees, solder it to the ground plane with the body of the resistor standing straight up, and continue installing parts, alternating between the legs of parts that go to ground and legs of parts that attach to the upper legs of parts that are grounded. You will be amazed at how fast and easy this is, and who cares if it isn't perfectly symmetrical or if there is no part label on the "PC" board.

If you run out of room in one direction on your PC board base, turn the corner and keep going. Or build part of the circuit on another board and tack solder them together. Think of how small a rig you can build if you put part of the circuit on the bottom, part on the sides, and part on the top of an all PC

board equipment case.

Because you have the choice of either building the complete circuit on one continuous sheet of PC board material that will end up being the bottom of your PC board material case, or building the circuit in sections, on small pieces of PC board material that can be tack soldered wherever your layout requires, this method is very flexible and lends itself quite readily to circuit changes, especially at the stage and module level.

Short pieces of hookup wire form the 12 Volt supply lines, and either short pieces of shielded wire or hookup wire connect the controls, switches, and the RF, power and ear-phone connectors to the circuit.

No high value resistors were used as standoff insulators, and no insulated soldering pads cut from PC board were needed other than those few previously mentioned. There are enough parts soldered directly to ground, and there is enough rigidity in part leads, to ensure that the components are mechanically stable without their use.

The main tuning pot, the RIT and RF Gain controls, and the two push-button switches for programming the Tick Keyer and Spotting the transmitter frequency are mounted on the front panel. The rear panel has the power connector, BNC RF output jack, and the paddle and headphone jacks.

The drawing below shows the general layout of the circuit as built on the PC board bottom of the case. Only the Tick keyer is on a small, separate board, which is tack soldered vertically to the rear panel of the PC board case.

In this layout, the finished size of each section is entirely up to the builder, as is the finished size of the whole. With this layout, the signal starts in the VXO, goes to the Buffer and Frequency Doubler, through the Double Tuned bandpass filter, and from there to both the transmitter driver and the receiver mixer. The input side of the transmitter driver faces the DT filter, as does the mixer side of the receiver, facilitat-

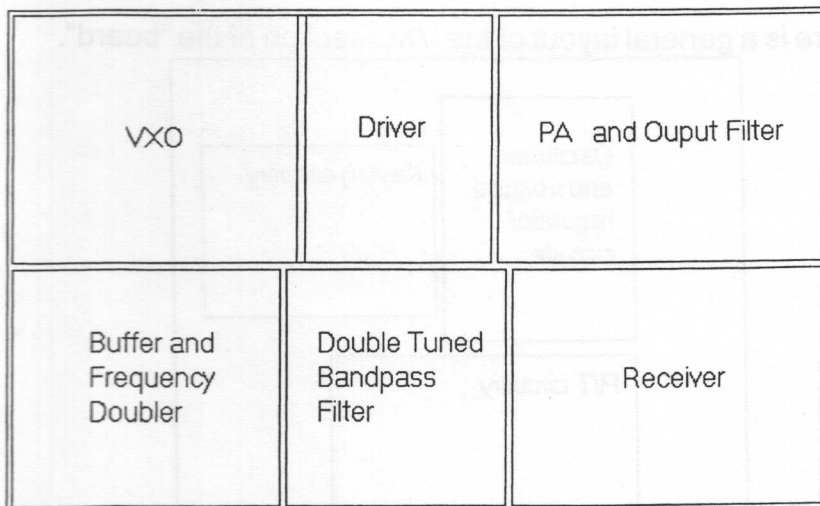

NB6M 10 Suggested layout

ing easy connections.

Use silver content solder, both for the stronger and cleaner solder joints it makes and for the reduction in lead exposure. I use two soldering irons of differing wattages, a low wattage iron for attaching parts to each other, and a medium wattage iron for soldering either parts or PC board sections to the PC board base. There is no need to bend part leads around each other. They should be touching, and the nice clean flow of a small amount of solder should cover their junction. If the first two parts are joined in this manner, it is easy to re-heat the joint and add each next part lead. You will quickly learn that having the far end of previously installed parts already soldered to their adjoining parts will prevent the junction you want to add to from falling all apart when you re-flow the solder.

Here is a general layout of the VXO section of the "board".

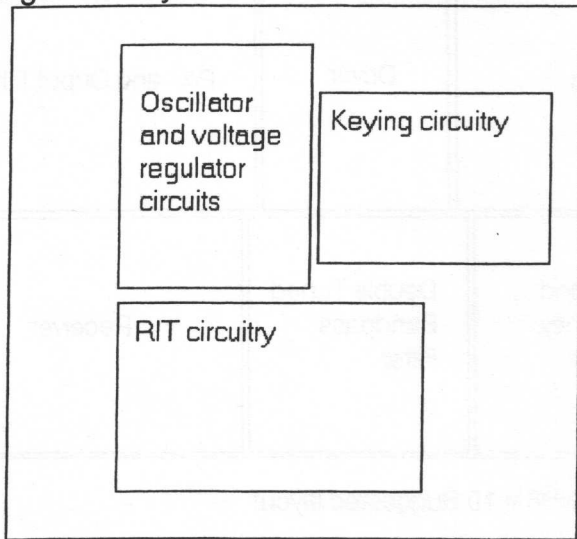

NB6M 10 VXO board general layout

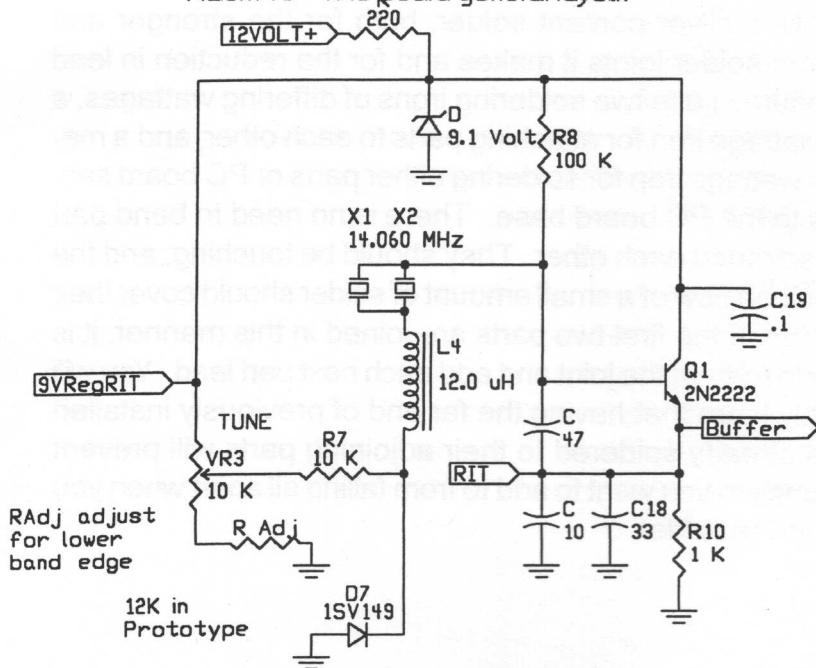

NB6M 10 VXO

Build the VXO first, starting with the oscillator itself, from the emitter up. Leave about $\frac{3}{4}$ " of free space on the board to the left of the VXO, which will be the front of the rig, so that the parts will clear the tuning pot and other controls.

Once the oscillator is built, including its voltage regulator, the "ground" leg of the tune pot, or a substitute, can be soldered directly to the edge of the board, the wiper is connected to the 10 K resistor leading to the tuning diodes, the top leg of the pot is connected to the top of the 9.1 volt Zener, and the oscillator can be tested. Either listen for its output in a receiver, or check its output with an RF voltmeter and frequency counter, at the emitter of the transistor.

The signal should be quite strong in a nearby receiver, and with the components listed, you should get 40 KHz or more of tuning range.

In my rig, the initial tuning range was 13.990 to 14.044 MHz. I put a 12 K resistor between the ground leg of the Tune pot and ground in order to fix the lower end of the tuning range just above the bottom of the band.

However, wait until the RIT circuit is installed before installing R-Adj, as it is labeled in the RIT Circuit, as that will slightly change the tuning range of the VXO.

Once you are satisfied the VXO is working properly, disconnect the power source and install the entire RIT circuit, beginning with the 15 pf cap that attaches at the junction of the oscillator transistor's emitter and the tops of the 1 K resistor, and the 33 and 10 pf caps. For the time being, the cathode of the 1N914 that will attach to the "key" line is left floating, unconnected.

Here is the RIT circuit:

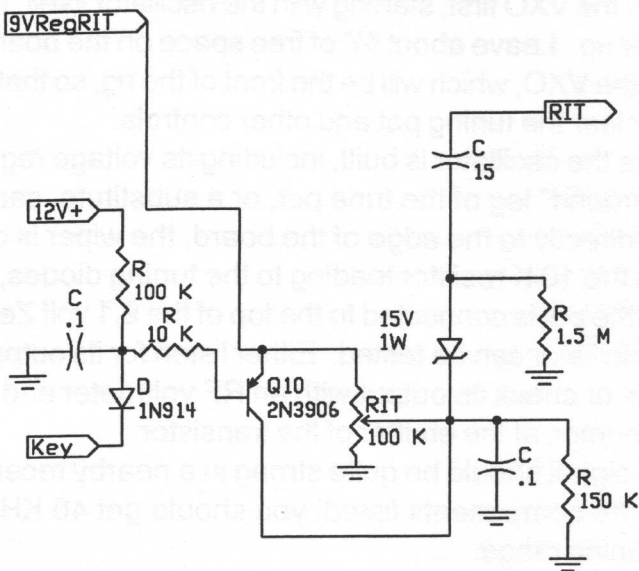

NB6M 10 RIT

Solder a cutoff part lead to one end leg of the RIT pot, and solder a couple of three inch long pieces of hookup wire to the other two legs. This way, the RIT pot can be connected to the circuit in order to test the RIT and TX frequency offset functions. The wiper of the pot connects to the cathode end of the 15 Volt Zener used in the RIT circuit. The leg of the pot opposite the ground leg is connected to 9.1 volts regulated at any convenient spot in the oscillator circuit.

Once the RIT pot is connected, apply 12 volts to the VXO circuit again, either hook a frequency counter up to the emitter of the oscillator transistor or listen to the second harmonic of the VXO in a nearby receiver, and check the function of the RIT. At the low end of the VXO tuning range, the RIT should change the 28 Mhz harmonic a total of about 2.7 KHz. At the upper end, it should provide about 1 KHz of total frequency change.

Then, with the RIT pot centered in its travel and the VXO at the low end of its tuning range, use a test lead with alligator

clips on each end to ground the cathode of the 1N914 that will eventually connect to the "Key" line. With it grounded, the VXO frequency should shift, and in this case about 1 KHz or so.

The exact amount of frequency shift depends on the position of the RIT control. At one end of the RIT knob's travel, there will be no frequency shift when the key line is grounded. At the other end of the RIT pot's travel, with the VXO at the low end of its tuning range, the frequency will shift about 2.7 KHz.

In my rig, the Tune pot is connected so that the VXO's frequency goes up as the pot is rotated clockwise, and the RIT pot is connected so that no shift occurs when the pot is turned all the way clockwise.

In practice, if one desires to listen to the same received tone throughout the entire tuning range of the rig, the received signal is zero beat while holding the "spot" push-button switch in, and then the "spot" switch is released and the RIT knob adjusted for the desired reception tone.

With this arrangement, popularized by Roy Lewallen, W7EL, in his "Optimized QRP Rig", one listens to the upper sideband of any received signal, in order to place the offset transmitter signal on frequency in the other person's receiver. Holding the "Spot" switch in while tuning the received signal to zero beat will ensure that the transmitted signal is exactly on the received frequency. Substituting a SPST toggle switch may make tuning easier, as the RIT can be switched off while tuning, then switched back on, without having to hold a push-button style switch in while doing so.

Now that the RIT Circuit is installed and working, it is time to install the resistor, R_{adj}, that determines the lower end of the tuning range. Assuming your VXO tunes below the bottom of the band, R-Adj will be needed so as to prevent out-of-band transmissions.

While either monitoring with another receiver or with a

Frequency Counter, tune the VXO just above the bottom of the 20 Meter band, say around 14000.5 KHz. Disconnect the power from the VXO, unsolder the wire connected to the wiper of the Tune pot, and, being sure not to turn its knob, measure the resistance from the wiper leg of the pot to ground. The resistance measured will be very close to that amount needed to keep the VXO from tuning below the bottom of the band. Install the next larger common value of 1/4 Watt resistor between the ground leg of the pot and ground, and re-connect the wire to the wiper.

Test the tuning range of the VXO to be sure it doesn't tune below 14000.0 KHz. As we will be transmitting the upper sideband of the VXO frequency, doubled to 28 MHz, this will ensure that we stay within the band with our transmitted signal. Just to be sure, re-check the low end of the tuning range while listening to the 28 MHz harmonic of the VXO.

Add the keying circuitry next, in its designated general area in the VXO section of the "board". Here is its circuit:

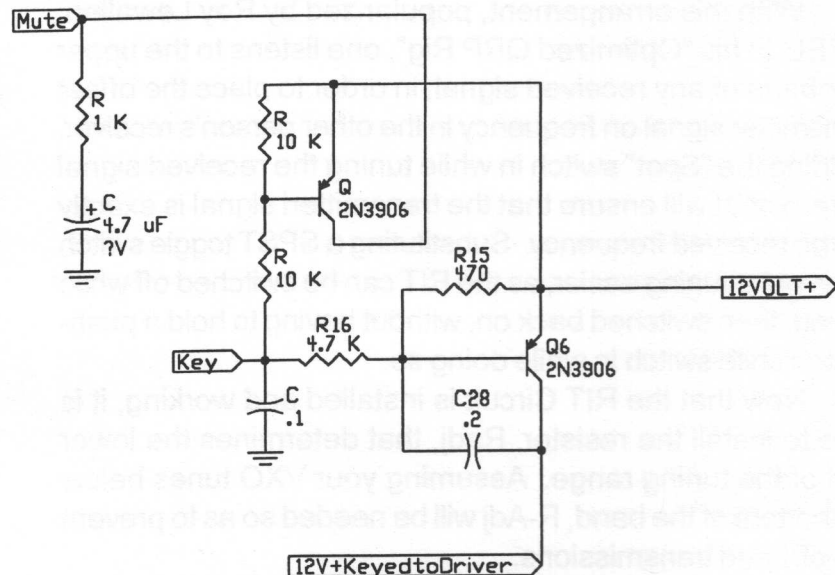

NB6M 10 Keying

In actuality, the 12 Volt "Bus" wiring will eventually run directly from the 12 Volt power jack to the PA stage and then on to the other various stages that require it, so, at present, the 12 Volt connection shown here is the same point as the 12 Volt connection for the VXO. The 12 Volts Keyed line to the driver will be added after that stage is built.

Once the keying circuitry is built, and 12 Volts applied, it can be tested by measuring the voltages on the Collectors of both keying transistors, as it will be 0 Volts when the rig is in "Receive" mode, and 12 volts when the Key line is grounded in "Transmit" mode.

The Key line connection shown here is connected to the Key line contact in the RIT circuit, and will be connected to the Key line contact in the Tick Keyer circuit, once that is built and added to the rig.

The general layout for the JFET buffer amp, Push-Push pull frequency doubler and double-tuned bandpass filter is as follows:

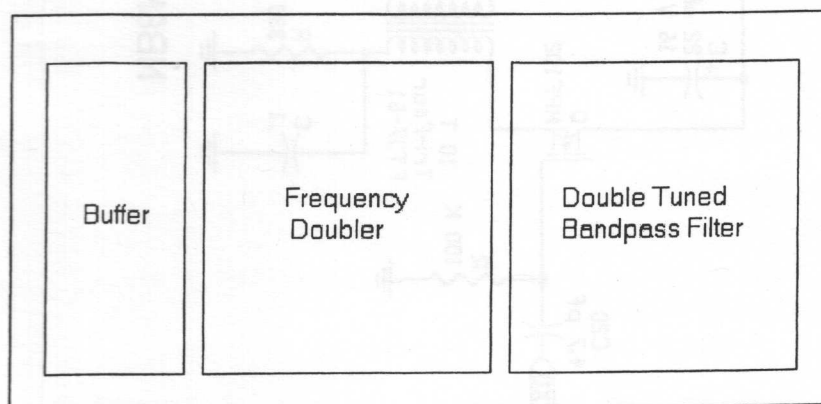

NB6M 10 Buffer, Doubler and Double Tuned Bandpass Filter general layout

Next, build the JFET buffer amp and the Frequency Doubler. Here is the circuit:

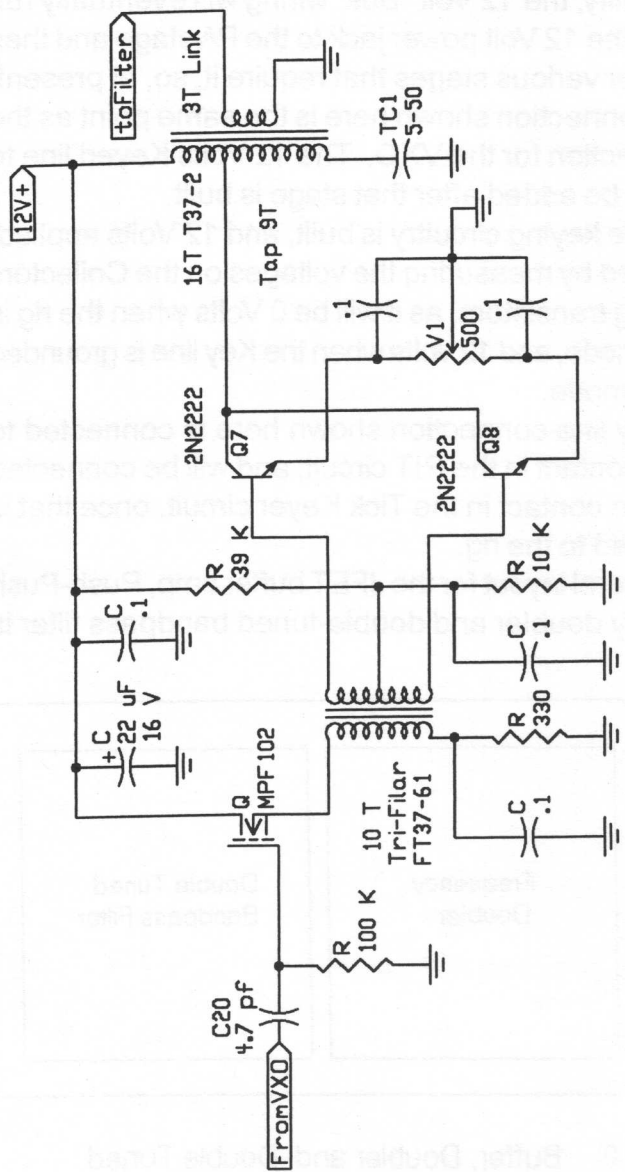

NB6M 10 Buffer/Doubler

Once the buffer and frequency doubler are built, test this stage. Bare necessity test equipment for use in this project should include an oscilloscope, a high impedance voltmeter with RF probe, a receiver capable of receiving both the 20

Meter and 10 Meter ham bands, and a 50 Ohm resistive dummy load. A wattmeter helps, but the voltmeter and RF probe will suffice if one is unavailable.

If you don't own an oscilloscope or other pieces of necessary test gear, a nearby ham should be more than glad to help you test and align stages as they are added to the circuit. I certainly extend that invitation to anyone in my area who wishes to build any gear that I can help with.

An oscilloscope is definitely a plus when alignment and adjustment of the push-push frequency doubler is performed, as one first adjusts the trimmer in the doubler output for maximum 28 MHz signal, and then adjusts the balance pot between the emitters of the push-push transistors for a minimum or null of the 14 MHz fundamental.

Either a 51 or 47 Ohm resistor is connected temporarily from the top of the 3 turn link to ground, and the signal monitored there. Once this section is aligned, DC power is disconnected and the resistor is removed.

The double tuned bandpass filter is built next, up to and including the 51 Ohm resistor which serves as its load. Here is its circuit:

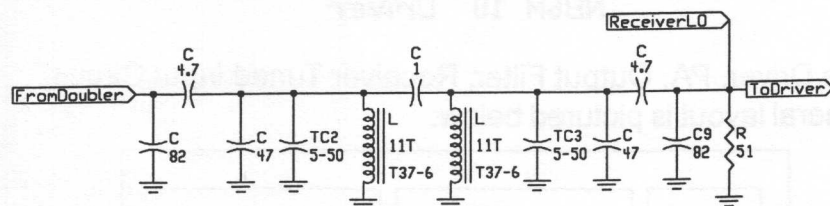

NB6M 10 Bandpass Filter

After re-connecting DC power, the filter is aligned by adjusting the two trimmers for maximum 28 MHz signal, and minimum 14 MHz fundamental, while observing the signal at the top of the 51 Ohm resistor at the output, on an oscilloscope. This adjustment should be performed with the VXO tuned to the center of its tuning range, so as to provide a

more uniform signal level throughout the entire tuning range.

Build the driver stage next, including the 22 Ohm resistor that goes from the top of the 3 Turn link on its output transformer to ground. Here is its circuit:

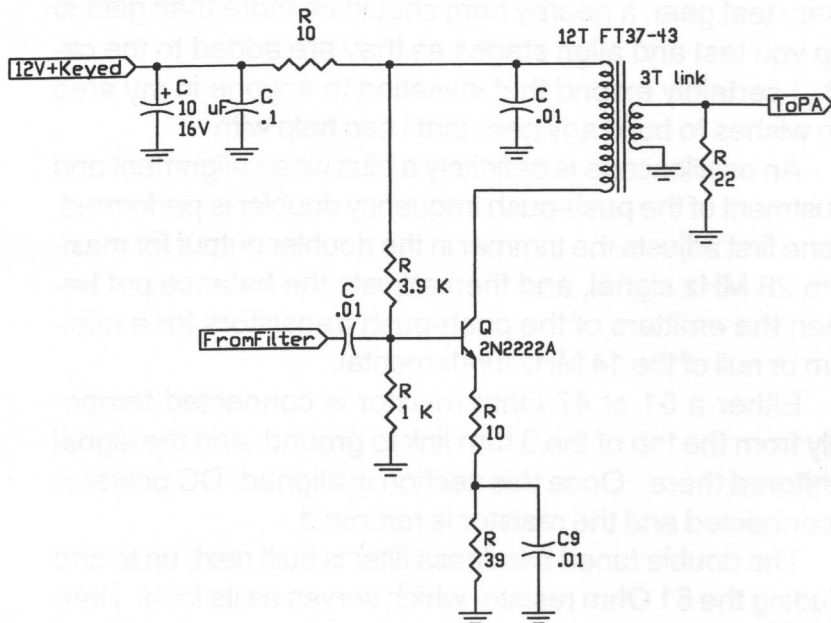

NB6M 10 Driver

The Driver, PA, Output Filter, Receiver Tuned input Circuit general layout is pictured below:

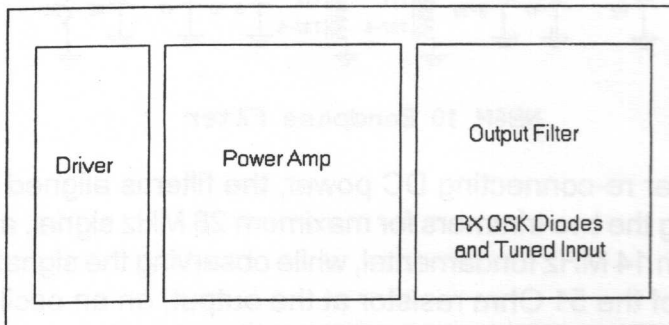

NB6M 10 Driver, PA, Output Filter and RX Input

Connect the 12 Volts Keyed line to the collector of Q6 in the keying circuit. Connect the 12 Volt DC supply line, and test the driver by either listening for an increase in 28 MHz signal in a receiver, by observing the output with a voltmeter and RF probe, or with an oscilloscope while grounding the Key line.

The PA stage and its output filter is built next, and connected to the BNC antenna jack. Include the trimmer TC1 and the two QSK diodes, D1 and D2 in the area of the output filter. Use heat sinks on the 2N3053 transistors.

The PA and output filter circuit is here:

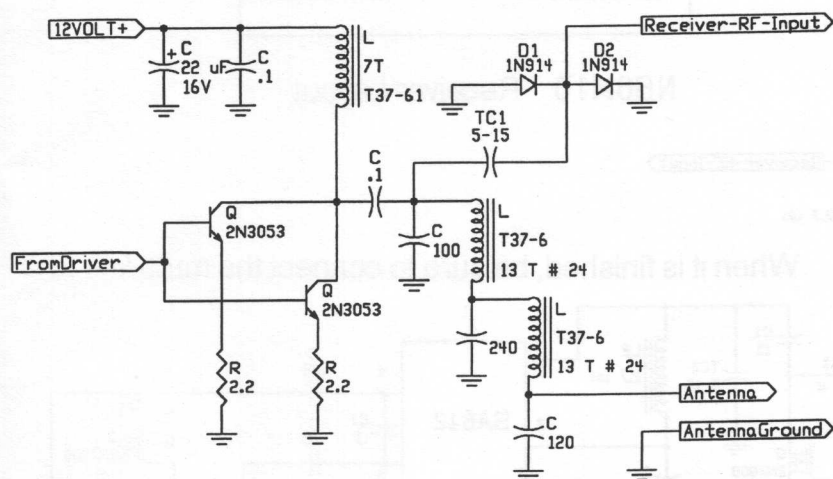

NB6M 10 PA

At this point, the transmitter is complete, and can be tested, by grounding the Key line while the transmitter is connected to a Wattmeter and Dummy Load, or while the output is monitored with Voltmeter and RF probe or Oscilloscope while connected to a Dummy Load.

The prototype rig's transmitter produces about 1.5 Watts of output.

Next is the receiver. Here is the general layout for the receiver and its muting circuitry:

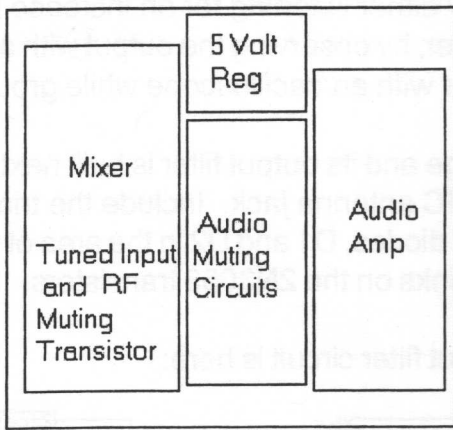

NB6M10 Receiver Layout

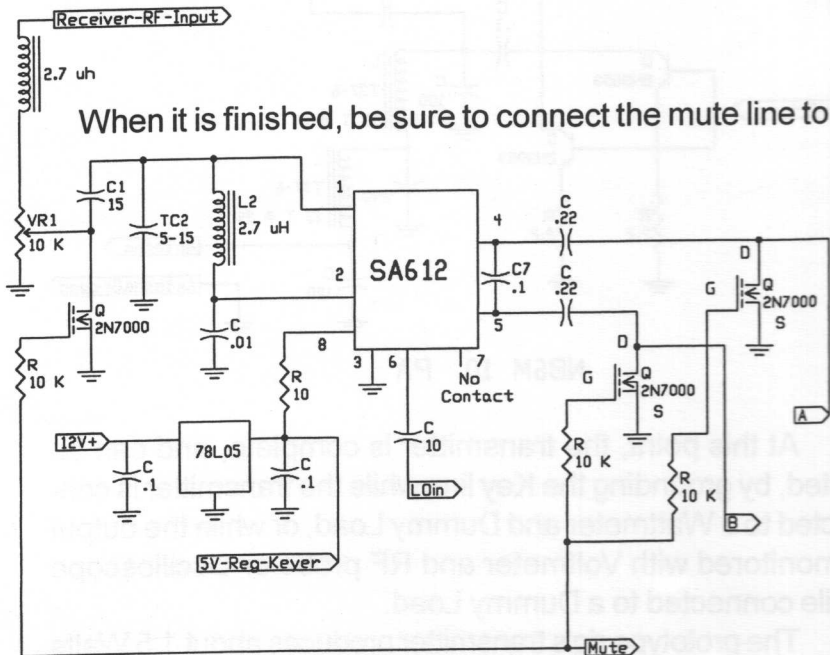

NB6M 10 RX Mixer & Muting

the top of the 1 K resistor in the Keying Circuit, at the point labeled "Mute", and connect the 10 pf cap from pin 6 of the IC to the top of the 51 Ohm resistor in the output of the DT filter.

The Receiver Audio amp circuit follows:

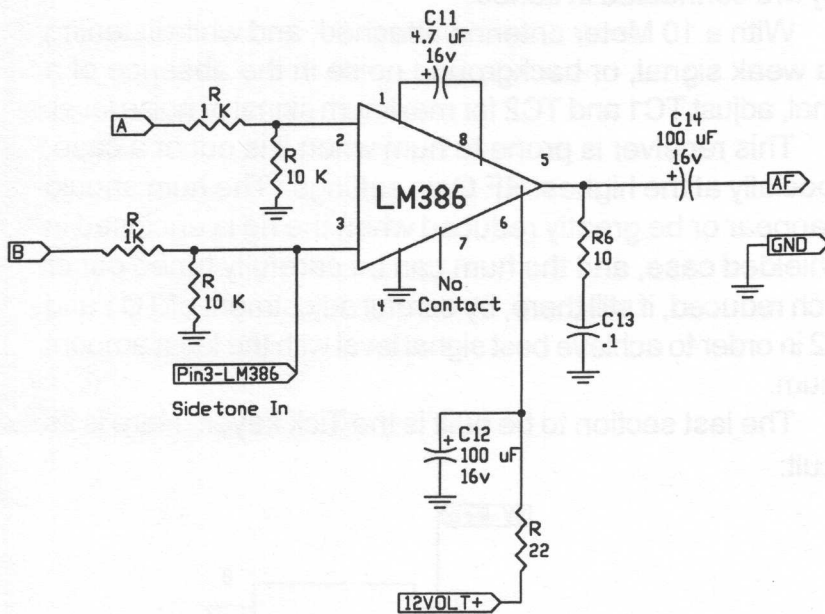

NB6M 10 RX Audio Amp

The RF Gain pot will be mounted on the front panel. Use shielded wires to connect it to both the RF input and the Receiver Mixer.

When the receiver section is complete, with the 12 Volt supply line connected and with an earphone jack connected between the AF output and ground, the receiver can be aligned and tested.

The earphone jack should be wired so that the AF output goes to the "tip" connection of the stereo earphone jack, and the ground connection goes to the "ring" connection.

When the jack is installed in the rear panel of the case, enough of the copper surface is scraped off both the inside and outside surfaces of the panel so that the "ground" connection of the jack is NOT grounded. Wiring the earphone jack this way provides higher audio output from the stereo earphones, as they are connected in series.

With a 10 Meter antenna attached, and while listening to a weak signal, or background noise in the absence of a signal, adjust TC1 and TC2 for maximum signal or noise level.

This receiver is prone to hum when it is out of a case, especially at the highest RF Gain settings. The hum should disappear or be greatly reduced when the rig is enclosed in a shielded case, and the hum can be carefully tuned out or much reduced, if still there, by careful adjustment of TC1 and TC2 in order to achieve best signal level with the least amount of hum.

The last section to be built is the Tick keyer. Here is its circuit:

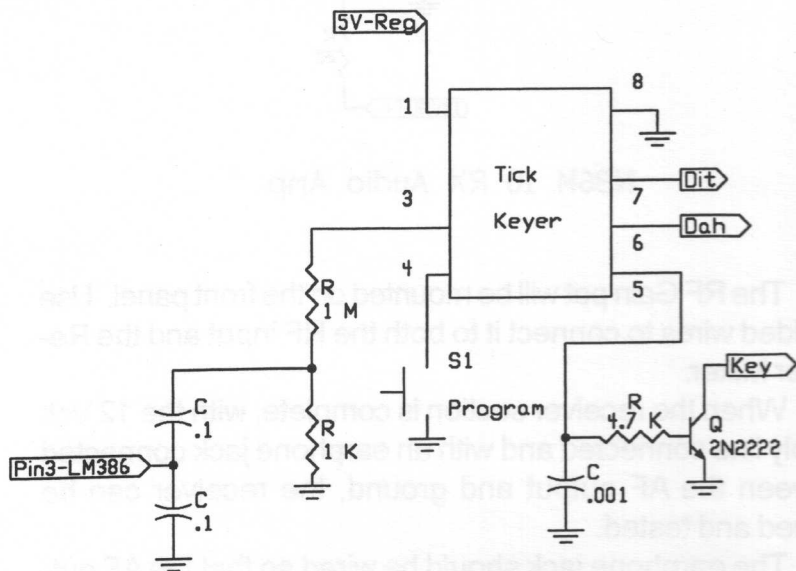

NB6M 10 Keyer

I built the keyer circuit on a small piece of double sided PC board that I tack soldered vertically to the inside surface of the rear of the case, near the top, between the Paddle jack and DC Power jack. This facilitated making its connections to the Paddle jack, receiver audio stage, and to the 5 Volt regulator. A piece of hookup wire connects the collector of the keying transistor to the Key line in the keying circuit.

Now it is time to build the front and rear panels of the case, and ensure that all the connections between stages are properly made.

Use the three general circuit diagrams as a guide to make sure all interconnecting lines are properly installed.

Here is a drawing of the NB6M 10's front panel arrangement:

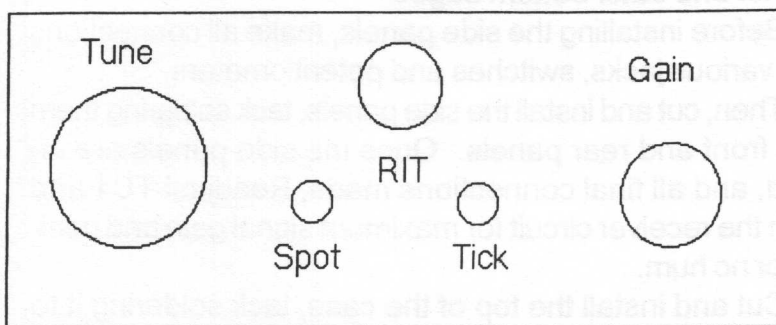

NB6M 10 Front Panel Layout

The rear panel layout is as shown here:

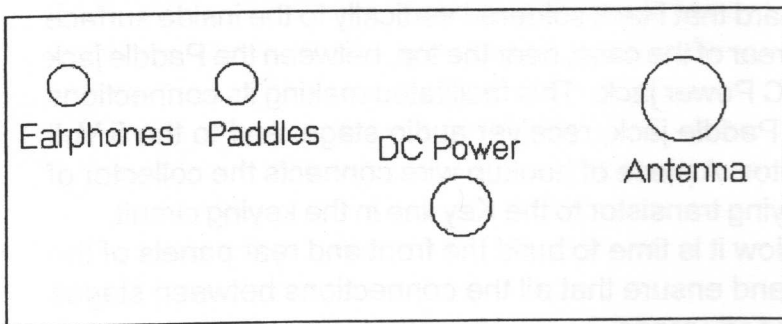

NB6M 10 Rear Panel Layout

The actual size of these panels is determined by the finished size of your layout, and can be cut accordingly. Use double sided PC board for the front and rear panels, and install them about an eighth of an inch inside the edge of the PC board base, so that they can be tack soldered on both the inner and outer bottom edges.

Before installing the side panels, make all connections to the various jacks, switches and potentiometers.

Then, cut and install the side panels, tack soldering them to the front and rear panels. Once the side panels are installed, and all final connections made, Readjust TC1 and TC2 in the receiver circuit for maximum signal gain and minimum or no hum.

Cut and install the top of the case, tack soldering it to the front and rear panels, and the rig is ready to use.

FINAL THOUGHTS

Although it is nearly impossible to exactly duplicate the layout of a circuit that is built "Ugly" style, it should be noted that exact duplication is not necessary. Stages can be built on individual pieces of PC Board, or not, as the builder desires. The size of the project is also up to the builder. If one is used to building only on PC boards, with exact parts place-

ment, this may seem daunting. However, ease and rapidity of construction coupled with clean RF operation of the circuitry and flexibility of layout and final project size and shape more than make up for the lack of a PC board and exact parts layout.

As always, building any project stage by stage, and testing each stage as you go, helps a lot.

This rig could certainly benefit from a more refined receiver. However, adding a simple DC receiver made this transceiver come together quickly and easily, and this receiver is adequate for many contacts. A DC receiver capable of single signal reception, such as the Mini-R2 would be a great alternate choice.

None of the parts used are unique or exotic. While the SA612 mixer ICs are getting scarce, with only Phillips manufacturing them, they are still available.

It is interesting how one simple ham radio experiment leads to so much more, in this case resulting in a fun little rig for a band that is not receiving as much attention, operation wise, as it should. In the short time since building the rig, contacts have been made across the United States and Canada, and several exciting DX contacts, including several in Europe, have been made as well.

It is my hope that some of the ideas presented here in this rig will provide the impetus for building projects of your own. The rewards, both in terms of learning and in the simple joy of operating a rig that you have built from scratch yourself, are well worth the effort.

Color pictures of the rig that show building details can be seen on the NorCal Web page at:

www.norcalqrp.com

Enjoy.

Wayne NB6M

QRPp Fall 2002

The NorCal 30 Presentation at Pacificon

by Doug Hendricks

The next big NorCal project will be the NorCal 30 Transceiver designed by Dan Tayloe, N7VE, with board layout and packaging done by Dave Fifield, AD6A. Both of these gentlemen spoke at Pacificon about the new rig. At press time (second week of November) this is the status of the rig: It is finished as far as design goes, and Dan has an ugly style prototype that he has measured and was able to determine the specs from. Dave is about 70% through with the first pass of the board layout, and it looks to be a 4 layer board, which will be a first as far as we know of for a club project.

The target price for the rig is about \$100, but we really can't price it or take orders until we finalize the design on the pc board. We have to build a few prototypes to make sure that the design transfers from the ugly style of construction to the pc board. While this is not difficult, it is a step that takes time and must be done right.

The following pages show the remarkable specs that Dan was able to achieve with his design. These are the actual slides that Dan showed us all at Pacificon, so this is your opportunity to share in the presentation through the pages of QRPp.

When will we take orders? Hopefully around Christmas time. Be sure to check the NorCal page at www.norcalqrp.com and qrp-l@lehigh.edu mailing list as that is where we will be announcing when we take orders, and how to place them.

The kit will be packaged in a case, and it will be a complete kit. All parts, case, controls and connectors provided.
72, Doug, KI6DS

Norcal 30 High Performance/Low power 30m Transceiver

Dan Tayloe, N7VE

Norcal 30 Novel Features

- High performance Quadrature DC Detector
 - *High Rcvr Sensitivity/Excellent large signal performance*
- Single sided reception with phasing receiver
- 3v low power receiver
- Switching supply minimizes current drain

Norcal 30 Specification Summary

- Receiver Type: Direct Conversion with Phasing
- > 45 db opposite sideband suppression
- Tuning range: 25 KHz, 10.1 – 10.125 MHz
- Receiver sensitivity: -136.5 dbm (0.1 uV), 3 db S+N/N
- Blocking: > +2 dbm
- Blocking Dynamic Range: > 138 db
- Third order intercept: > +25 IP3
- IM Dynamic Range: > 107 db
- No Spurious SW Broadcast AM Detection
- *Rcvr Blocking/IP3 better than practically useful*

Norcal 30 Specification, Cont.

- Transmit: Variable power, 5w max
- Operating voltage: 12v nominal
- Current drain
 - Receive with moderate signal: 13.5 ma at 12v.
 - 10.5 ma at 16v,
 - 18 ma at 9v
 - Transmit, 5w output: 780 ma at 12v.
- Simple RIT provided (0 to ~800 Hz offset)
- Tick keyer
- SSS Audio Frequency Annunciator

Receiver Audio Response

Measured Using 30m Band Noise

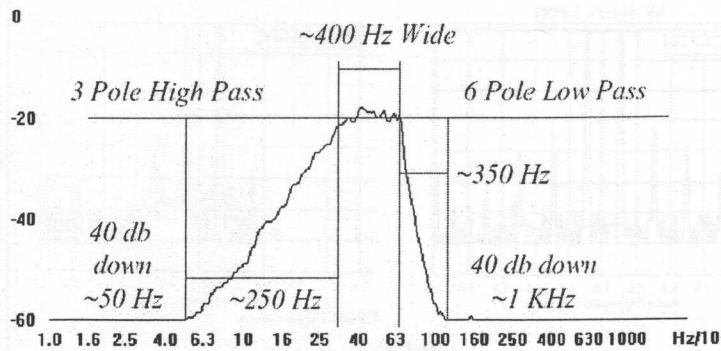

Two Tone Audio IM Response

Test demonstrates linearity/clarity of the audio chain

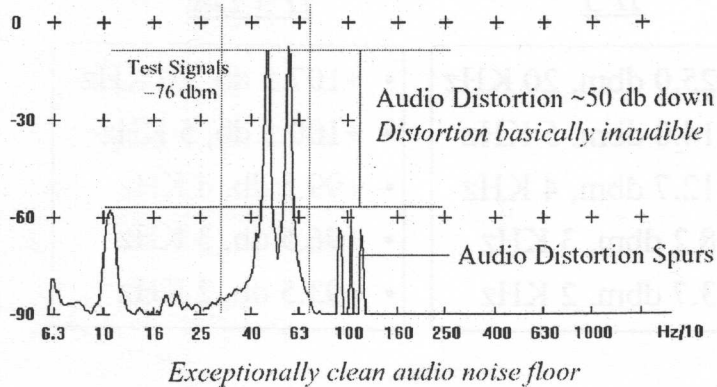

Two Other Audio IM Examples

FT-1000MP

S9 Signal Level

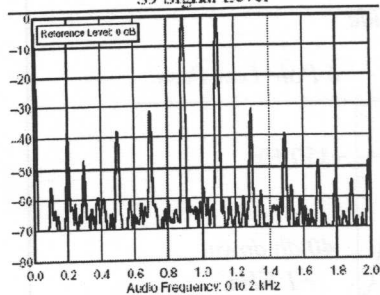

K2

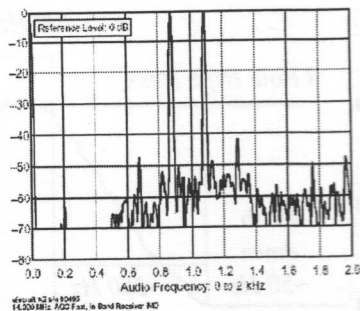

Data taken from ARRL Web Page

Norcal 30 Close in IP3 (low side)

IP3

- +25.0 dbm, 20 KHz
- +14.0 dbm, 5 KHz
- +12.7 dbm, 4 KHz
- +8.2 dbm, 3 KHz
- +3.7 dbm, 2 KHz

IP3 DR

- +107.5 db, 20 KHz
- +100.5 db, 5 KHz
- +99.5 db, 4 KHz
- +96.5 db, 3 KHz
- +93.5 db, 2 KHz

Rig Comparisons

- Rig performance data taken from Adventure Radio Society web site.
- The ARS contains a wealth of information comparing the performance of various QRP radios with full size rigs.

www.natworld.com/ars

Receiver Sensitivity

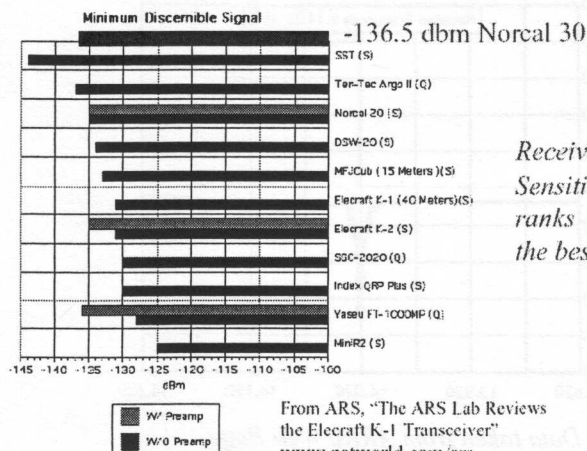

Receiver Sensitivity ranks among the best.

Third Order Dynamic Range

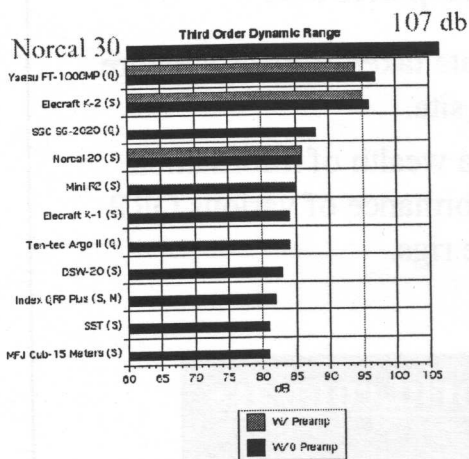

Norcal 30 excels in third order dynamic range.

From ARS, "The ARS Lab Reviews the Elecraft K-1 Transceiver" www.natworld.com/ars

K2 – IP3 Dynamic Range

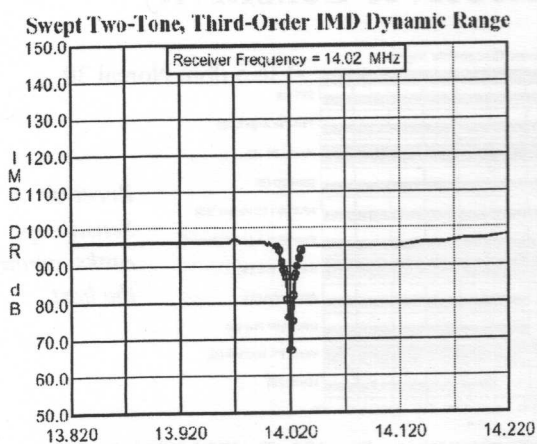

Data taken from ARRL Web Page

Close in IMDR: Norcal 30 vs. K2

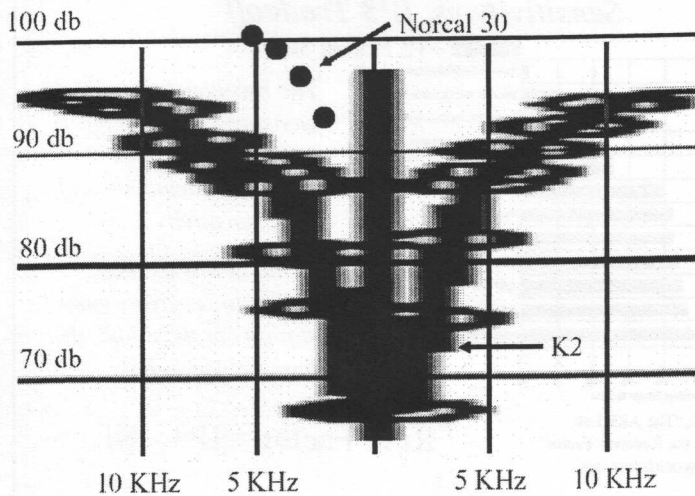

Blocking Dynamic Range

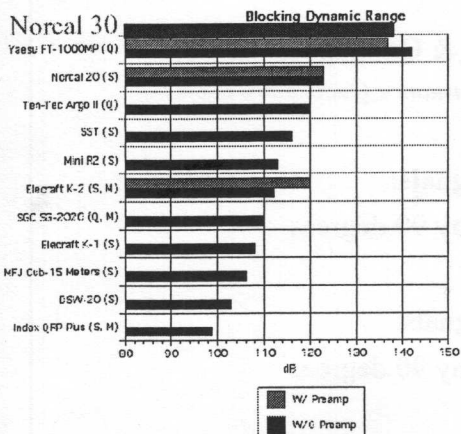

Blocking Dynamic range is bested only by the FT-1000MP

From ARS, "The ARS Lab Reviews the Elecraft K-1 Transceiver"
www.natworld.com/ars

ARS – Receiver Factor

Sensitivity vs. IP3 Tradeoff

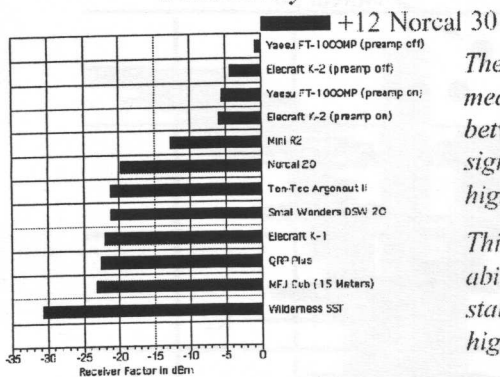

The receiver factor measures the tradeoff between high level signal performance and high sensitivity.

Think of this as the ability to receive weak stations in the midst of high power signals.

From ARS, "The ARS Lab Introduces the Receiver Factor" www.natworld.com/ars

$$\text{Rcvr Factor} = \text{IP3} - \text{NF}$$

How Does Phasing Work?

- Requires quadrature (I & Q) signals as input
– Taken from High Performance Quadrature Detector
- For Norcal 30 USB Signals:
I leads Q by 90 degrees
- For Norcal 30 LSB Signals:
Q leads I by 90 degrees

Picture of Two Sidebands

USB – I leads Q

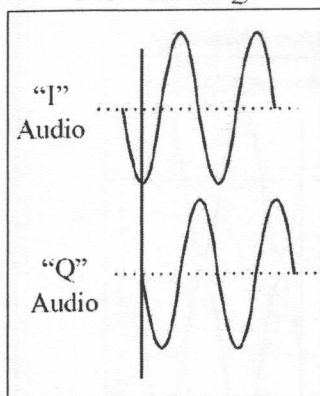

LSB – Q leads I

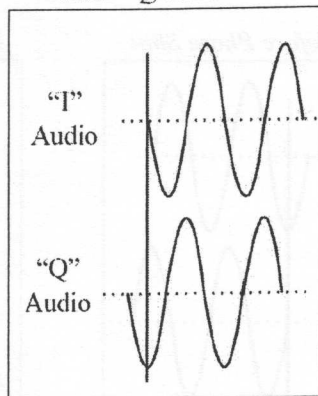

Amplify "As Is" to get a "Binaural" Receiver

Additional 90° Phase Delay Trick

- Trick: Use Phase delay network to add an *additional 90° shift* between I and Q
- Now LSB I & Q are in phase
- While USB I & Q are 180° out of phase
 - *After phase shift, LSB signals add while USB signals cancel.*

Before and After - USB

USB - Before Phase Shift

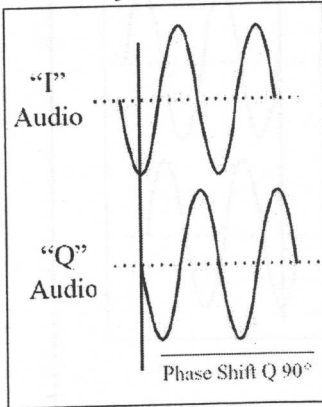

USB - After Phase Shift

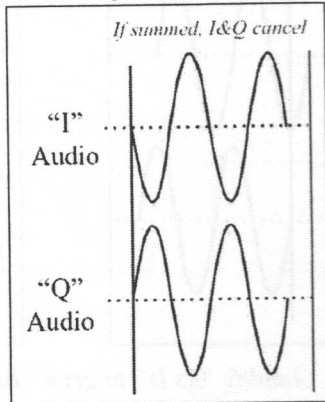

Before and After - LSB

LSB - Before Phase Shift

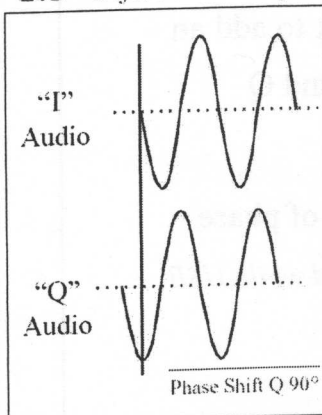

LSB - After Phase Shift

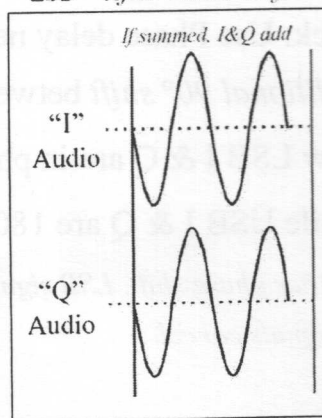

Norcal 30 Phasing Network

- When I/Q audio is applied to the phasing network, the USB sideband cancels out
- Component tolerances non-critical
- Opposite sideband rejection > 45 db
- Sideband rejection set using 3 trim pots
 - Balance / Low frequency / High frequency
- **Several passes through all three trimmers easily sets opposite sideband rejection**

Norcal 30 Phasing Network

90 Degree Phase Delay Network

Caps with * are miniature 5% stacked metallized caps such as the Panasonic V series

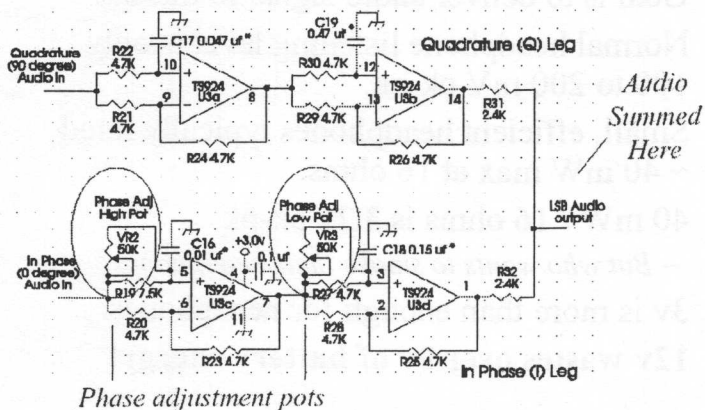

HB Phasing Strip

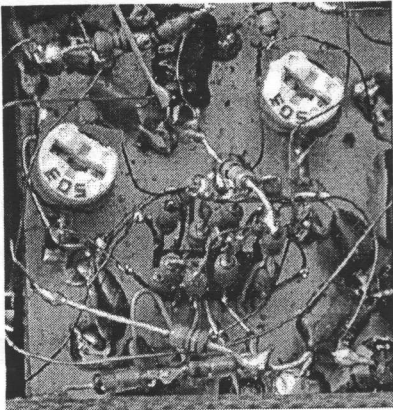

Why use a 3v Receiver?

- Goal is to deliver audio signal to the ear.
- Normal headphone listening level is only 100 to 200 mV pk-pk.
- Small, efficient headphones typically rated ~ 40 mW max at 16 ohms.
- 40 mW / 16 ohms is 3.2v pk-pk
 - *But who wants to smoke their headphones?*
- 3v is more than enough for headphones.
- 12v wastes over 9v of battery energy!

Why Use a Switching Supply?

**To waste less power
when using 12v!**

Rough Guidelines

(3 ma at 3v) = (1 ma at 12v)

(2 ma at 5v) = (1 ma at 12v)

Switching Supply Savings:

32 ma vs. 13 ma

- Total: 25 ma, 3v and 7 ma, 5v; ~110 mW
- Linear LDO Regulators provide clean 3v, 5v
 - With 3.3v/5.5v in, LDO regulators burn 10%, 11 mW
- Switching Supply output: 3.3v, 5.5v
 - Switcher circuit is about 75% efficient at 12v
- Switcher: 161 mW in, 121 mW out
- Switcher input, ~13.4 ma at 12v
- **If no switching supply: 32 ma**
- *Switcher saved ~19 ma at 12v.*

HB QRP Switching Supply

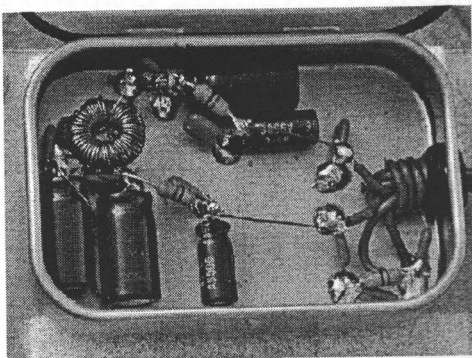

Altoids mini-tin magnetic shielding

Summary: Norcal 30 Design

- High performance Quadrature DC Detector
 - *Unmatched Overall Receiver Performance*
 - *High Rcvr Sensitivity/Excellent large signal performance*
- Single sided reception with phasing receiver
 - *> 45 db of USB suppression*
- Low power receiver
 - *3v, 110 mW*
- Switching supply minimizes current drain
 - *Only 13.5 ma at 12v*

QRP Operating

By Richard Fisher, KI6SN
1940 Wetherly Way
Riverside, CA 92506
KI6SN@yahoo.com

QRP ambitions on the Very High Frequencies

Alan Kaul, W6RCL, writes from La Canada, CA, that in the ARRL June VHF Contest he "operated a total of 5-hours QRP from DM04 (12-miles northeast of Los Angeles City Hall) and - while not burning up the band - enjoyed the contest.

"I had one opening on 6 meters into British Columbia, Washington and Oregon, and a couple of hours later another opening into Idaho on 6 meters.

"I heard no East-West signals at all."

Overall, Alan had 42 QSOs on 6 meters and 6 multipliers; 18 QSOs on 2 meters with 5 multipliers and 5 QSOs on 432 MHz in 4 multipliers for a total of 65 contacts in 25 multipliers and 1,750 points.

"My QSO No. 31 on 6 meters with W7QH in CN84, was 2 x QRP. He was also running 5 watts, but I don't know what the rig was.

If I remember correctly, he said he was also running a three-element Yagi.

"There may have been other QRP stations in the list of those worked, but I didn't make a big deal out of telling anybody, and neither did the other stations I worked.

"I did not identify as QRP except 2-3 times. The station was an FT-817, 3 element 6 meter Yagi at about 45-feet with a 175 foot coax run; 4 element Yagi on 2 meters at 15 feet (30 feet of coax, temporarily mounted on my front porch), and 10 element Yagi on 432 at 12 feet - below the 2 meter

Yagi on same mast, also with 30 feet of coax.

"The long coax run is a potential killer. On HF it is not a problem, but if I put the Yagis for 2 meters and 432 MHz on the crankup, I fear the signal loss through the extra length of coax would outweigh any potential gain by being 30-feet higher.

"If you had any QSOs during the VHF QSO Party, I urge you to send in your logs and to suggest (SOAPBOX - with your entry) that the sponsoring ARRL create a pure 5-watt QRP category in next year's contests.

"When 6 meters is open, distances of a thousand miles a watt are easily possible. Six wasn't that open (during the June VHF Contest weekend), and so the best I was able to do was about 200 miles per watt.

"Nonetheless, 1,000 miles on 5 watts is still respectable."

QRP at the campsite on Pyramid Lake

"Well, it wasn't exactly the best weekend as portable operations go," writes **Trevor Jacobs, KG6CYN**, of Burbank, CA.

"We arrived at a campsite at Pyramid Lake (near Los Angeles) around 10 p.m., so setting up the station on the first night was out of the question, as we had the tent to put up and people to chat with that we hadn't seen in a while.

"I got up Saturday morning, and as everyone was heading to the lake, I figured that I'd get a few hours of radio time in.

"By the time I'd had breakfast, cleaned up, got the station set up (FT-817 and MP-1) and was ready to operate, it was close to 10 o'clock.

"I listened around on 10 meters thinking that here may be an opening, but nothing was heard. Fifteen was the same. This brings us to around noon.

"I decided to move down to 20 meters and see if I

could hear any activity here. Didn't hear anything around 14.060, so I called CQ a few times with no takers.

"Then I moved up to the SSB portion of the band and heard a few strong stations chatting, so it appeared that the band was open.

"A few minutes later I heard Scott, N0OBA calling CQ from Aurora, CO. He was having a hard time receiving me, so we cut it short. At least I knew the rig was working, though.

"I decided to call CQ a few times and Bob W2NGK/5 from Albuquerque, NM came back and mentioned that he had monitored my last QSO with Scott and that I was a solid 56 out his way and 100 percent readable, so I started to feel a little better.

"Right about that time, I decided to go back down to 14.060 and try to round up at least one CW QSO while the band was open.

"I heard quite a bit of activity and decided to listen for a signing station to pounce on.

"This approach seems to work the best for me - or answering a CQ. As I was listening to a very strong station, it sounded as though someone had just pulled the antenna down.

"All of a sudden, the band went completely dead - no CW, no digital, no SSB, nothing.

"I checked WWV at 10 MHz, and there was nothing. I checked all of the bands and heard nothing. I knew that one of two things had just happened, and both would mean potentially no more radio for the day.

"Either A) the receiver in my FT-817 had just (bit the dust), or we had some kind of major solar event. Well, I gave my friend Dave, WD4PLI, a call on the phone and had him fire up his rig.

"To both of our surprise, the bands were indeed completely dead, deader than I've ever heard them. Well, at this point, since the truck was in the shade and all the kids were

at the lake (quiet!), I decided to take a little nap and try again later.

"About an hour or so later the group from the lake showed up so we hung out for a bit and ate some lunch. During lunch, the wind really picked up, and before I could get to the MP-1 antenna that was set up on the top of my Blazer, the wind blew it off the truck and snapped off the top section of the whip!

"Well, I wasn't too happy about that, but I took some Gaf tape and taped the section back on and also did a better job of securing the tripod.

"Sure could have used a couple of small sand bags to secure the tripod, but I made do with what was available.

"After we finished eating, I re-tuned the antenna and listened around a bit to see if 20 meters had come back to life. Well, I heard no CW at all.

"But I did hear one station in Georgia, as the GA QSO Party was going on that weekend.

"Anyway, I gave W4CEB a shout and he came back with a 57 report. And that was all she wrote.

"After that QSO I ended up spending some time with our friends and drinking a few chilled 807s.

"The weather was typical for camping in this area - hot in the day and chilly at night.

"All in all, it was still a fun trip, even though the radio end of it didn't go quite as planned.

"The DSW never saw the light of day! I did realize on this trip that I need to come up with some better strategy for portable antennas.

"The MP-1 is a great little antenna for 20 and above. Heck, I've worked Japan on 10 meters with it at 2 watts!

"But I'd like something for 30, 40, and 80 meters as well that would be more efficient. The wire antennas generally do great also, but a lot of times - especially on the beach - there are no places to hang them."

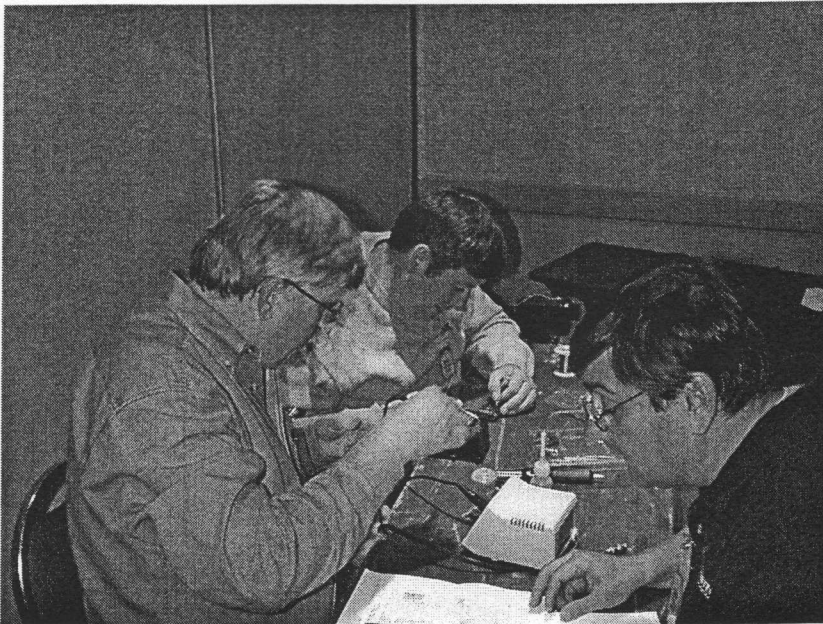

Mike Gipe and Dave Fifield struggle with their Rockmite

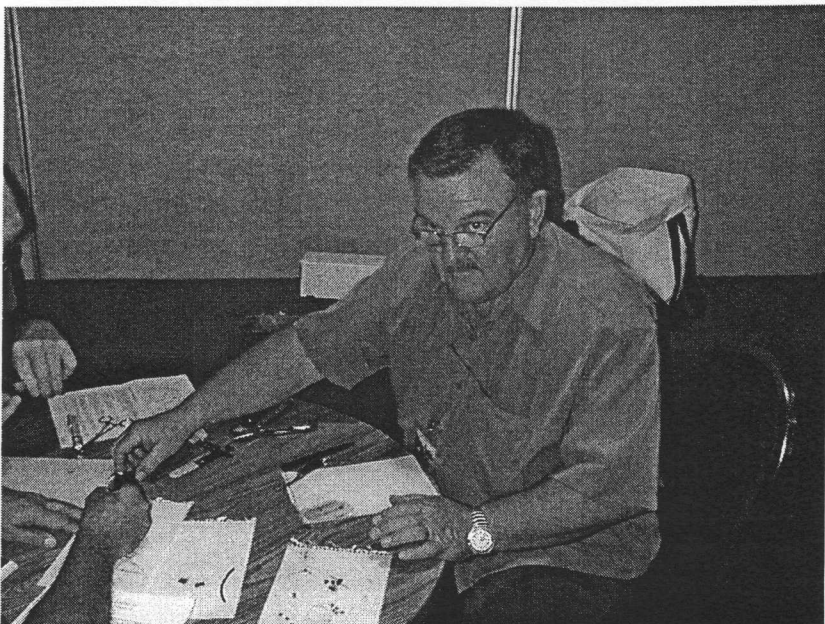

Jerry Parker, NorCal Webpage Webmeister enjoys Pacificon!!

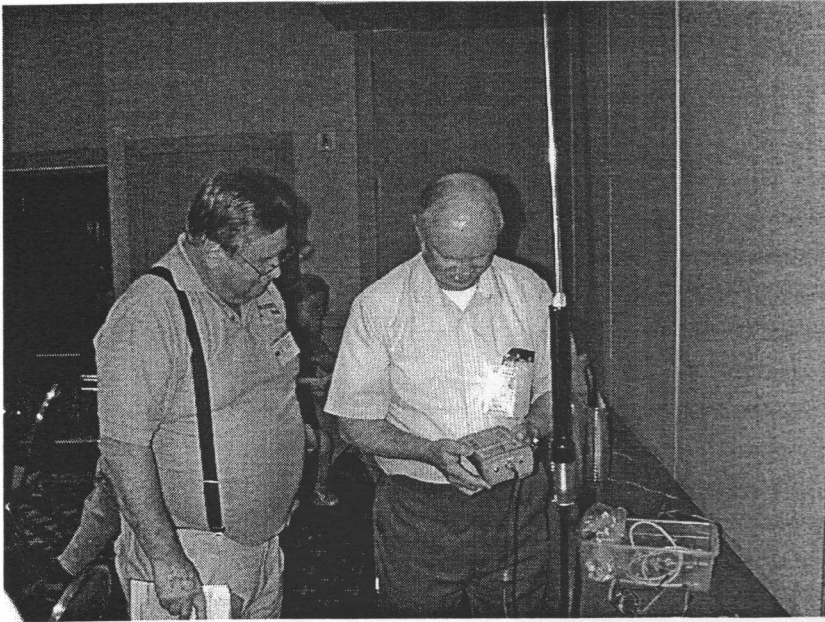

Vern Wright, L, and Bob Tellefsen adjust an antenna at Pacificon



Rod Cerkony and Jan Medley build Rockmites during Pacificon Building Contest.

The NorCal Web Page

NorCal maintains a web page that has many late breaking announcements of interest to QRPers. Our web master is Jerry Parker, WA6OWR. Please check the web page at:

www.norcalqrp.com

Subscription problems?

Paul Maciel, AK1P maintains the NorCal Database. If you have a question concerning your subscription please contact Paul at: ak1p@earthlink.net or by mail at:

PAUL A MACIEL
1749 HUDSON DR
SAN JOSE CA 95124

QRPP Subscriptions

QRPP is printed 4 times per year with Spring, Summer, Fall and Winter issues. The cost of subscriptions is as follows:

US and Canadian addresses: \$15 per year, issues sent first class mail. All DX subscriptions are \$20 per year, issues sent via air mail. To subscribe send your check or money order made out to Jim Cates, Not NorCal to:

Jim Cates
3241 Eastwood Rd.
Sacramento, CA 95821

US Funds only. Subscriptions will start with the first available issue and will not be taken for more than 2 years at a time. Membership in NorCal is free. The subscription fee is only for the journal QRPP. Note that all articles in QRPP are copyrighted and may not be reprinted in any form without permission of the author. Permission is granted for non-profit club publications of a non commercial nature to reprint articles as long as the author and QRPP are given proper credit. Journals that accept paid advertising, including club journals, must get prior permission from K16DS before reprinting any article or part of an article. The articles have not been tested and no guarantee of success is implied. If you build circuits from QRPP, you should use safe practices and know that you assume all risks.

**QRPP, Journal of the NorCal QRP Club
862 Frank Ave.
Dos Palos, CA 93620**

**First Class Mail
U.S. Postage
Paid
Mailed from Zip Code
93620
Permit #72**

Larry Wise KA5T
206 Sinuso Drive
Georgetown, TX 78628

First Class Mail

Subscription expires with Winter 02 issue.

NB6M 10 HomeBre

Receiver and keying

Wayne

2002

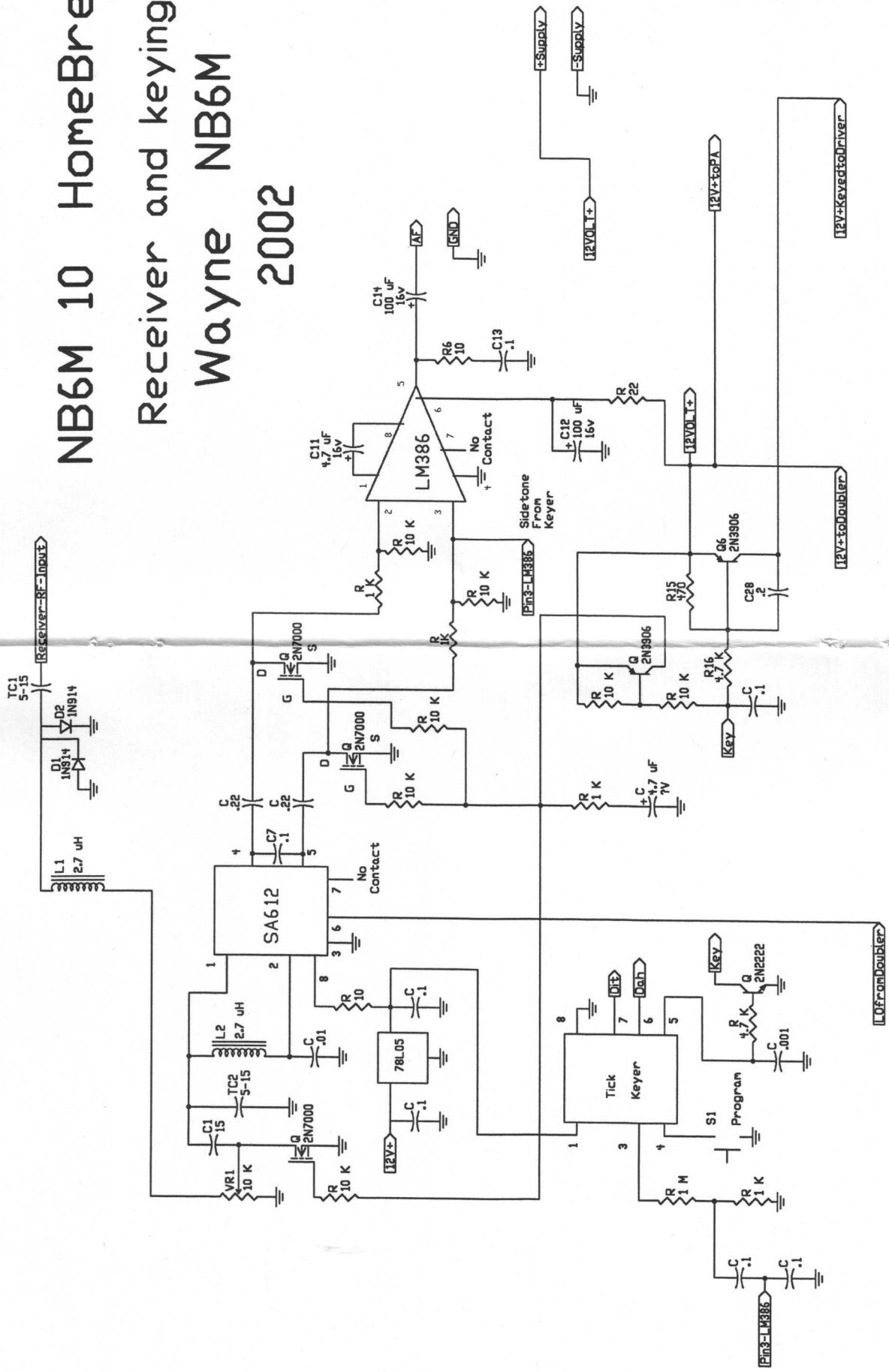

Volume X No. 4

Winter 2002

QRPP

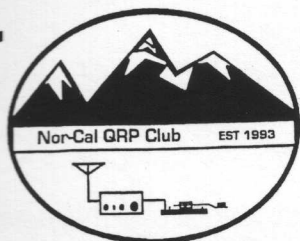

Winter 2002

Journal of the Northern California QRP Club

Table of Contents

Handiman's Guide to MOSFET "Switched Mode" Amplifiers: Part 1

Paul Harden, NA5N 3

HF Vertical Travel Antenna - Updated:

Phil Salas - AD5X15

A Review of Short Antenna Design

Jim Pepper W6QIF 23

Using an Oscilloscope and Load Resistor to Estimate RF Power

George Baker, W5YR 41

"SPaddle" – A Lightweight Vertical Paddle

Seab Lyon, AA1MY 44

KK5PY's Te Ne Tuner

Lew Pacely, N5ZE 47

How to Build the NorCal Doublet Antenna

Doug Hendricks, KI6DS 50

From the Editor

Doug Hendricks, KI6DS

You will note a couple of things about this issue. One there aren't as many pages as usual, and two, I have gone back to 10 point type and 2 columns. Why? Because of the increase in printing costs. To keep the costs down to where we can afford to print and mail QRPp without raising the subscription rates, we have had to do this. I did the issue in the old way, 12 point type and 66 pages, and guess what, there is actually more information in this one than in the old way of doing things.

You will also note that this is a double issue. Everyone who has an expiration date of Winter 2002 will also get the Spring 2003 issue in the same mailing. We ask that

you please renew by sending in \$15 US and Canday (US Funds of course) and \$20 DX to:

Jim Cates
3241 Eastwood Rd.
Sacramento, CA 95841

Please mark your check renewal as that helps Jim and Paul Maciel immensely. Note that your renewal will start with the Spring 2003 issue.

Jim and I both want to thank you for all of your support and we appreciate all that you do for QRP by participating. Have a good year and we hope to see you in person at a QRP Forum or on the air. 72, Doug, KI6DS

The Handiman's Guide to **MOSFET "Switched Mode" Amplifiers**

Part 1

Introduction to Class C,D,E and F

by Paul Harden, NA5N

Part 1 is a tutorial for using switching MOSFET's for QRP power amplifiers. Beginning with the standard Class C power amplifier, special emphasis is given to the Class D, E and F high efficiency modes.

Meet the MOSFET

MOSFET's have been used for years in QRP transmitters, but with an apparent level of mysticism as to how they really work. There are two main types of mosfet's: the linear RF mosfets, such as Motorola's "RF Line," and the more common switching mosfets. The **RF mosfets** are excellent, reliable devices for up to 30MHz, and some VHF versions. However, they cost \$25-35 each or more, and beyond the budgets of most amateurs. **Switching mosfets** are far more common, such as the IRF510, available at hobby vendors and Radio Shack for about \$1. These cheap switching mosfet's are the ones used in most home brew QRP transmitters, and the ones upon which this article focuses.

As the name implies, this family of mosfet's are designed to be *switches* -- that is, to primarily turn current on or off, just like a switch or relay. They are not perfect. Between the OFF and ON states, there is a linear region. Compared to standard bipolar transistors, mosfets have a narrower linear region. IRF510s, used for QRP Class C PA's, attempt to bias for this

more restrictive linear region. However, if the device is accidentally driven into saturation, it causes excessive drain current and heating of the mosfet -- and often failure. If you haven't blown up an IRF510 yet -- you just haven't worked very hard at it!

The IRF series of switching mosfets were developed by International Rectifier.. They make the "dies" for these mosfet's, marketing them under their own name (logo "I-R"), or selling the dies to other manufacturer's, such as Motorola and Harris, who merely adds the TO-220 packaging. Thus, no matter where you get your IRF510, you are getting the same device and can be assured of consistent operation.

The exception to this are some IRF510s sold by Radio Shack. Some are manufactured in Haiti that may or may not meet specs for maximum drain current, or at what gate voltage the device turns on and reaches saturation. To avoid legal problems with I-R, Radio Shack packages these mosfet "clones" under the part number IFR510 (not IRF510). An unrecognizable logo indicates a device manufactured off-shore.

Most power mosfets are made by stacking several dies in parallel to handle higher currents. The disadvantage is the capacitances add in parallel, which is why power mosfets have large input and output capacitances over single die devices. Mosfets made by vertically stacking the dies are called VMOS, TMOS, HexFets and other such names.

According to the I-R applications engineer, the IRF510 is their most widely sold mosfet. This is because it was developed by I-R in the 1970's for the automotive industry as turn-signal blinkers and headlight dimmers to replace the expensive electro-mechanical switches and relays. The good news is, this implies they will not be going away any time soon. In talking to International Rectifier, they were floored to find out QRPers were using them at 7MHz or higher. I faxed them some QRP circuits to prove it. Quite a difference compared to the 1Hz blink of a turn signal, or the 50kHz rate of a switching power supply!

BJT's vs. MOSFET's

Bipolar junction transistors (BJT) are forward biased with a base voltage about 0.7v (0.6v on most power transistors). Below 0.7v, the

transistor is in *cut-off*: no collector current is flowing. Above 0.7v, collector current begins to flow. As you increase the base voltage (which is actually increasing base current), it produces an increase in collector current. This is the *linear region* – converting a small change on the base to a much larger change on the collector. This defines amplification. As you continue to increase the base voltage further, a point will be reached where no further increase in collector current will occur. This is the point of *saturation*, and the point of maximum collector current. The base voltage required to saturate the transistor varies from device to device, but typically falls in the 8v range for most power transistors used for QRP PA's. This is, actually, a fairly large dynamic range. A graph showing these regions is called the "transfer characteristics" of a device, as illustrated in **Fig. 1A**, showing a sample Class C input and output signal. Self-biasing is assumed, that is, the input signal is capacitively coupled to the base with no external (0v) bias.

MOSFETs work in a very similar manner, except the gate voltages that defines cut-off, the linear region, and saturation are different than BJT's.

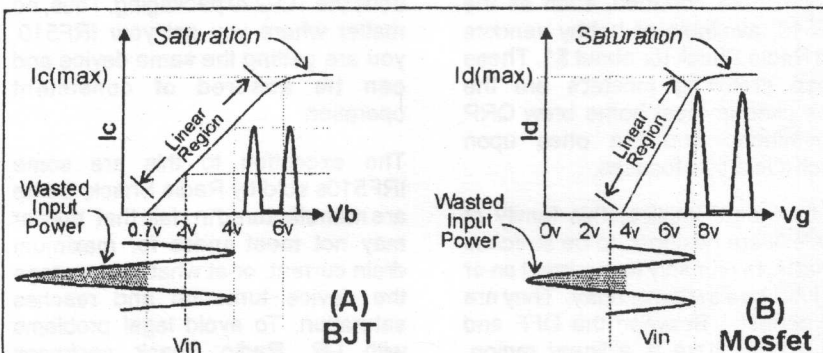

FIG. 1 – Class C Transfer Curves for (A) NPN bipolar transistor (self-biased) and (B) IRF510 mosfet at 3v gate bias

While it takes about 0.7v to turn on a BJT, it takes about 4v to turn on an IRF510 mosfet. The voltage required to cause drain current to start flowing is called the *gate threshold voltage*, or $V_{gs(th)}$. From the IRF510 data sheet, the $V_{gs(th)}$ is specified at 3.0v minimum to over 4.0v maximum. This large range is typical of mosfets, whose parameters tend to be quite sloppy compared to BJT's – something to always keep in mind. My experience shows the $V_{gs(th)}$ of the IRF510 is more in the 3.7-4.0v range and goes into full saturation with about 8v on the gate. This defines a smaller dynamic range (4v-8v) for the linear region than a BJT (0.7v-8v).

The transfer characteristics of a typical IRF510 is shown in Fig. 1B. The gate is externally biased at 3v (no-signal) and the input signal is limited to no more than 7v on the peaks to avoid the saturation region. Note that the scaling between the BJT and mosfet transfer curves are different.

Class C PA with a BJT

Figure 2 is a typical schematic of a QRP transmitter PA using an NPN power transistor. RF input from the driver stage is stepped-down through

T1 to match the very low input impedance of Q1, typically 10Ω or less. The low output impedance (12-14Ω at 5W) is converted to about 50Ω by the 1:4 step-up transformer T2. This circuit is the common *self-biasing* circuit – there is no external dc biasing applied to the base, such that the signal voltage alone forward biases the transistor. Referring back to Fig. 1A, the shaded area of the input signal shows the power that is wasted in a typical Class C PA using self-biasing. This is power from the driver that is *not being used to produce output power*. This is an inherent short coming of the Class B and C amplifiers.

Class C PA with a MOSFET (IRF510)

The circuit of a typical mosfet Class C PA is shown in Figure 3. It appears very similar to the BJT circuit in Fig. 2 in most regards. The RF input signal from the driver stage can be capacitively coupled, as shown, or transformer coupled. Capacitive coupling is easier for applying the external biasing. Since the $V_{gs(th)}$ of an IRF510 is about 3.5-4.0v, setting of the gate bias, via RV1, should initially be set to about 3v to ensure there is *no drain current with no input*

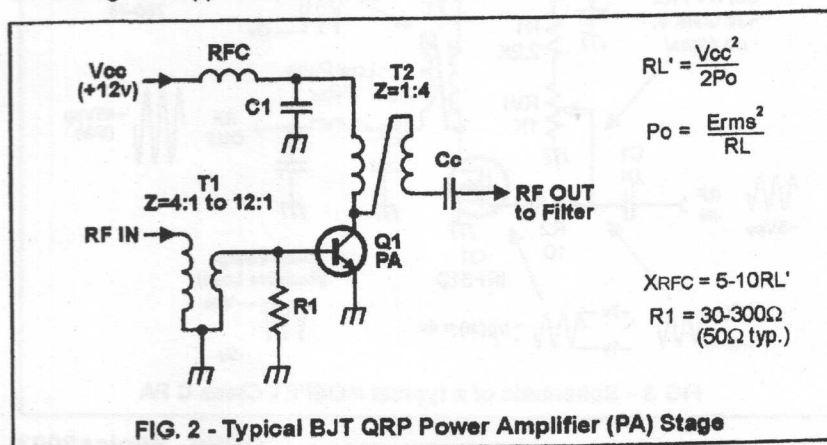

FIG. 2 - Typical BJT QRP Power Amplifier (PA) Stage

signal. R1 is chosen to simply limit RV1 from accidentally exceeding 8v on the gate, which would cause maximum drain current to flow and certain destruction after 10–15 seconds. The input RF applied to the gate (during transmit) should likewise never be allowed to exceed about 7–7.5v, just shy of the saturation region. As illustrated, the input signal is 8Vpp, or -4v to +4v after C1, and after the +3v biasing, from -1v to +7v. This ensures the IRF510 is operating within its safe operating area for a Class C amplifier. Like the BJT Class C PA, the input signal from +4v to -1v is wasted power, not being converted to output power.

For a typical Class C PA operating at around 50% efficiency, about 850mA of drain current will be required to produce 5W output. It is wise to monitor the drain current to ensure excessive current is not being drawn, indicating the RF input peaks are approaching the saturation region of the device, or the static gate voltage from RV1 is set too high. This is extremely important to preserve your IRF510 longer than a few moments!

Drain current will only flow when the

gate voltage exceeds the $V_{gs(th)}$ of the device. With a resistive drain load, this translates into +12v of drain voltage when no current is flowing, then dropping towards 0v as drain current flows, as shown in Fig. 3. However, with the inductive load of T1, the voltage swing will be $2V_{cc}$ (24v) as expected. This is due to the current stored in the inductance of T1 being dumped into the load (low pass filter) when drain current from the IRF510 stops, and is stepped up further, by a factor of two, to about 48Vpp, by the bifilar windings on T1. Some loss through the low pass filter yields about 45Vpp for 5W output.

Once the circuit is working properly, RV1 can be carefully adjusted to produce more power, again carefully monitoring for <1A of current flow. This is much easier to do with an oscilloscope, to ensure that the gate voltage never approaches the 7.5–8v saturation region on the RF peaks, and for a fairly clean sinewave entering the low pass filter.

Evaluating Class C MOSFET Efficiency

A well biased IRF510 PA can be a bit

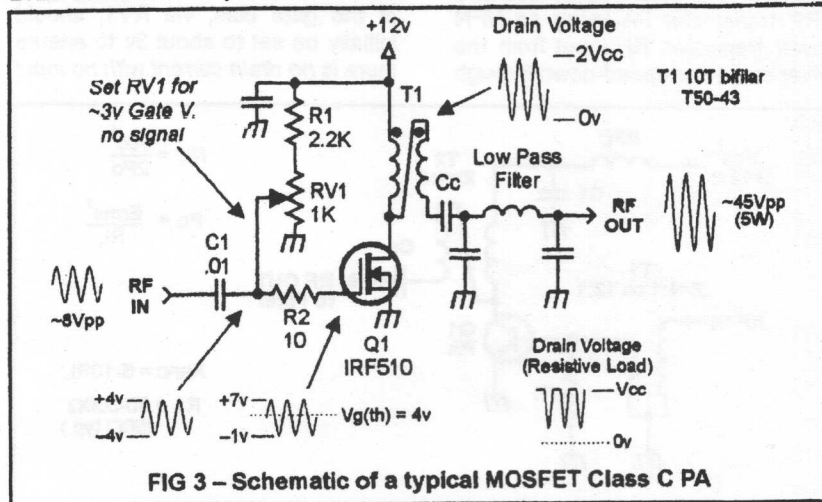

FIG 3 – Schematic of a typical MOSFET Class C PA

more efficient than a BJT circuit, primarily because it takes less peak-peak input signal to produce 5W, and thus less driver power is needed. Since the slope of the linear region is steeper than a BJT, the IRF510 actually has more potential gain.

The largest contributors to power losses, and hence poor efficiency with switching mosfets, are the very large values of input and output capacitances compared to a BJT.

Remember how you've always heard the input impedance of a mosfet is very high, in the megohms? Well, forget you ever heard that! That is the *DC input resistance* of the gate with *no drain current flowing*. The AC input impedance is the X_c of C_{in} (about 120–180pF) or 130Ω at 40M. This means your driver stage must be able to provide an 8Vpp signal into a 130Ω load, or about a *half watt of drive*.

On the output side, the large output capacitance, C_{out} , is like having a 120pF capacitor from the drain to ground. This absorbs a fair amount of power being generated by the mosfet. But there is nothing you can do about that (at least in Class C).

The other large contributor to reducing efficiency is the power lost across the drain-source junction. This is true as well across the collector-emitter junction in a BJT. Power is $E \times I$. The power being dissipated across the drain-source junction is the drain voltage (V_d) times the drain current (I_d). When no drain current is flowing, there is no power being dissipated across the device, since $+12v \times V_d \times \text{zero}$ is zero. But for the rest of the sinewave, you have instantaneous products of $V_d \times I_d$. Looking at the mosfet again as a switch, this is known as the *transition loss*, as drain current is transitioning from its OFF state ($I_d=0$), through the linear region, to the ON state ($V_d=0$).

Of course with Class C, you are in the transition loss region at all times while drain current is flowing. Again, there is little you can do about this loss in Class C amplifiers.

Improving Efficiency (Introduction to Class D/E/F)

From the above, it appears there are three major sources of power loss, leading to poor amplifier efficiency:

- 1) Transition (switching) losses ($V_d \times I_d$ products)
- 2) Large internal gate input capacitance (~120-180pF for the IRF510)
- 3) Large internal drain-source capacitance (~ 120pF for the IRF510)

If these losses could be largely overcome, then the amplifier's efficiency could be greatly improved.

In class D/E/F, the mosfet is intentionally driven into saturation using a square wave. This drives the mosfet from OFF ($I_d=0$), to fully ON ($V_d=0$) as quick as possible. The square wave input will have to go to $\geq +8v$ to ensure saturation.

This purposely avoids the linear region, operating the device only as a switch. For this reason, Class D, E and F amplifiers are often called *switched mode amplifiers*, not linear amplifiers, as in Class A, B or C.

The transfer curves of a Class C vs. Class D/E/F PA with a square wave drive is shown in Fig. 4. The gate is biased at 3v in both cases, and $V_{gs(th)}$ is 4v. The amount of wasted input power is greatly reduced with the square wave drive. The output will have a slope on the rising and falling edges, due to the short time drain current must travel through the linear region. Still, the ON-OFF switching action of these modes is evident.

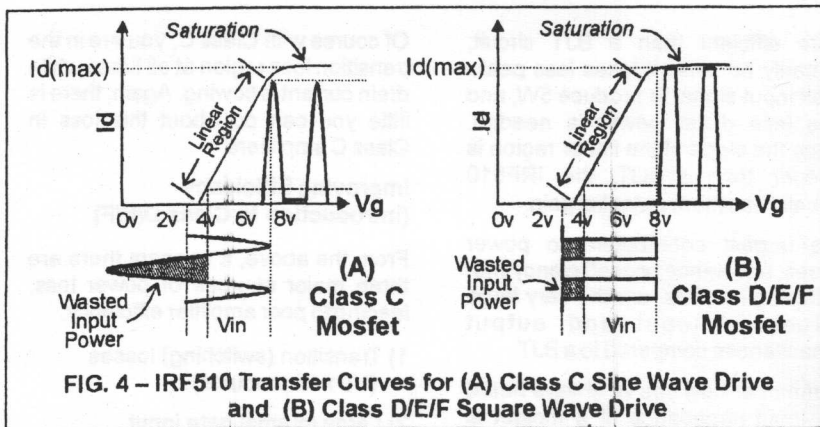

A square wave is an infinite combination of odd harmonics. The square wave output must be converted back into a sine wave by removing the harmonic energy before being sent to the antenna for FCC compliance. *The method by which the fundamental frequency is recovered from the square wave output determines whether it is Class D, E or F.* In all cases, it is based on driving the mosfet with a square wave input.

Legally, you can drive a mosfet into saturation with a huge sine wave as well, as many Class D/E circuits on the internet or ham radio publications are based. However, you are in the saturation region for a relatively short period of time (only during the positive input peaks), the rest of the time in the linear region. It is this authors opinion that the first step to increasing efficiency is avoiding the lossy linear region. This is defeated with a sine wave drive.

Therefore, the remaining discussion on Class D, E and F amplifiers are based strictly on a square wave drive.

It is worth mentioning an important distinction between the classes of amplifier operation. With *linear amplifiers*, the class of operation is

based on the amount of time that collector or drain current flows: 100% for Class A, >50% for Class B, and <50% for Class C. However, the amount of time drain current flows in a *switched mode amplifier* has nothing to do with it's class of operation. It is based entirely on how the output power is transferred to the load and how harmonic power is removed.

CLASS D QRP PA

One implementation of a **Class D** QRP transmitter is shown in **Figure 5**. Note that there is little difference between the Class D PA, and the Class C mosfet PA shown in **Fig. 3**, other than being driven with a square wave and into saturation. One advantage of a square wave drive is it can be generated or buffered with TTL or CMOS logic components, making a 0v to 5v TTL signal, as shown. RV1 is again set for about 3v, which now corresponds to the 0v portion of the square wave, elevating the ON or HI portion of the square wave to +8v (+5V TTL + 3v bias), the minimum gate voltage to slam the mosfet into saturation. This is verified with an oscilloscope by monitoring the drain voltage, and noting that it falls nearly to 0v. A good IRF510 in saturation should drop to $\leq 0.4v$.

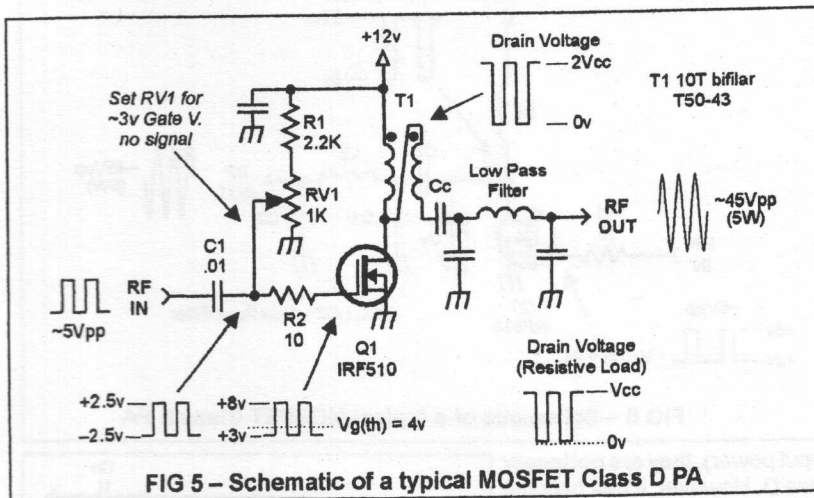

Speaking of oscilloscopes, having one is virtually required to properly build and tune Class D, E or F amplifiers. One must really be able to see what the waveforms look like, the voltages, and the timing (or phase) relationships to ensure the amplifier is operating properly.

The output circuitry is also identical to the linear Class C amplifier of Fig. 3, impedance converted through T1, followed by a traditional reciprocal (50Ω in – 50Ω out) low pass filter. Input resistor R2 is a low value resistor, 3.9Ω to 10Ω, to dampen the input Q a bit and prevent VHF oscillations. The value is not critical. A ferrite bead could be used as well (but a small value resistor more available).

Controlling the Output Power of the PA

Note that the input signal, as shown in Fig. 4, depicts a square wave with a 50% duty cycle. One of the beauties of switched mode amplifiers is the ability to change the output power by changing the duty cycle of the input square wave.

Remember that with an IRF510 in saturation, you are drawing about the maximum rated drain current, about 4A. This, of course, is way too much current to draw for any length of time. With the circuit shown, 5W is produced with about a 30% duty cycle, drawing about 800mA of total transmit current (including driver stages) for an overall efficiency of ~70%. You are "pulsing" the 4A ON and OFF to produce an *average* desired current, and hence output power. The shorter period of time the mosfet is ON, the lower the average power.

Final thoughts on Class D

Class D amplifiers were initially developed for hi-fidelity audio amplifiers, converting the audio into pulse width modulation (PWM). Class D really defines an amplifier that uses PWM for generating *varying* output power, such as audio.

The basic fundamentals have been applied to CW RF amplifiers, by simply driving the mosfet PA into saturation. Since these amplifiers do not use a PWM input (since a CW transmitter demands a constant

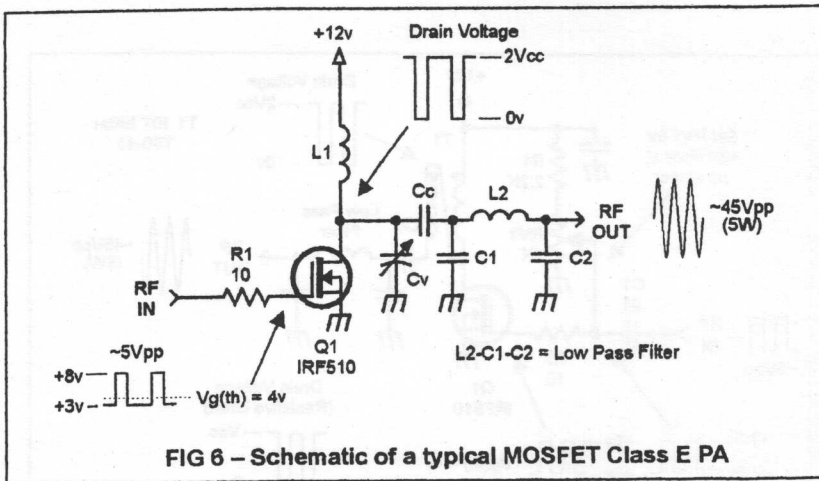

output power), they are not legally Class D. However, it has become accepted to refer to a mosfet PA, being driven into saturation with standard low pass output filters, as Class D.

For those wishing to experiment with these hi-efficiency switching amplifiers, start out with a simple Class D to see how they work and note the increase in efficiency. However, I would certainly recommend to any serious builder to graduate to a Class E PA.

CLASS E QRP PA

The first Class E QRP transmitter to be considered is shown in Figure 6. The input is a 5Vpp square wave at the RF frequency, ranging between +3v and +8v due to the R1-RV1 bias network in Fig. 5, or as developed in the driver stage. The real difference, which defines this circuit as Class E, is the output side of the mosfet. A single inductor, L1, replaces the common bifilar transformer, and a variable capacitor, Cv, is placed from drain to ground. The output is capacitively coupled through Cc to the low pass filter.

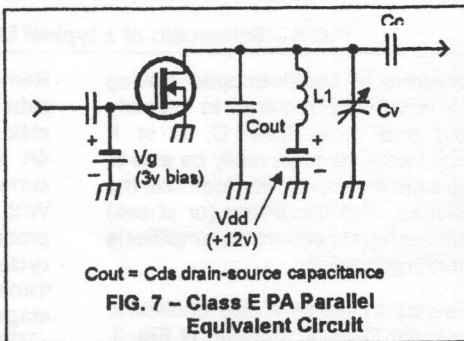

To better understand this circuit, refer to the equivalent schematic in Figure 7. The IRF510 output capacitance, C_{out} or C_{oss} , is 100-120pF, which would normally be an unwanted low impedance load to the drain circuit. However, in Class E, this output capacitance is used to our advantage by using it as part of a tuned circuit. Representing the +12v drain voltage as a battery, it can be redrawn to show how L1 is in parallel with C_{out} , forming a tuned circuit. Therefore, in Class E, the value of L1 is calculated to resonate with C_{out} at the desired output RF frequency. A fixed or variable capacitor, Cv, is usually added to the L-C circuit to reach resonance at the transmit frequency.

A parallel tuned circuit has very little net loss. Converting the mosfet's *Cout* from a loss element, to a low loss tuned circuit, is what *greatly increases the efficiency of this amplifier*. The current needed to charge *Cout* in Class E comes from the "flyback" energy of the tuned circuit, *not from the mosfet drain current*. In a properly tuned circuit, current flows through *Cout* only when the mosfet is OFF (no drain current flowing).

The combination of reducing the switching losses by using a square wave input, and reducing the effects of the internal capacitances, is what defines Class E.

Table 1 shows some initial starting values for the HF ham bands. *Cs* is the *total shunt capacitance* to add between the drain and ground – a fixed capacitor in parallel with the variable capacitor, *Cv*. On 40M, for example, this is a *total drain-source capacitance* of 240pF, including the internal *Cout* of the IRF510. The inductance, and the toroidal inductor to wind, is also shown to form the equivalent tuned circuit. I have built Class E PA's with these approximate values for all bands shown, except 80M, and all yielded an overall efficiency (total keydown current, including receiver and transmit driver currents) of at least 80%. However, these values need to be used with caution, primarily because the IRF510 *Cout* of 120pF, as listed on the data sheet, is for a *Vd* of +12v, that is, when the IRF510 is OFF. It rises to about 200pF as you approach saturation. The trick is to guesstimate what the average IRF510 capacitance will be, depending on the duty cycle of the input square wave. To be truthful, it takes a little piddling around to get it right, but getting another percent or two of efficiency out of the PA is fun. In fact, it can

Table 1 – Initial Values

BAND	Cs	L1	WIND L1
80M	270p	8.0uH	10T TBO-43
40M	120p	2.1uH	6T TBO-43
40M	120p	2.1uH	20T TBO-2
30M	120p	1.0uH	14T TBO-6
20M	47p	0.8uH	13T TBO-6
15M	—	0.8uH	10T TBO-6

become an obsession! Again, this is where an oscilloscope, and a power meter, is a must to tune the Class E PA for maximum efficiency. In practice, the *Cs* capacitance values listed in Table 1 will likely end up being a bit less than shown.

Note the square wave input shown in Fig. 6 is depicted having a 30% duty cycle, not 50% in the Class D circuit. Output power is determined by varying the duty cycle of the input drive. With Class E, it is my experience that maximum efficiency occurs around 45% duty cycle of the input gate drive (45% ON, 55% OFF).

CLASS E QRP PA with Series Tuned output

Figure 8 shows another implementation of a Class E amplifier. Instead of using an LPF output filter, a combination of parallel and series tuned resonant circuits are used. As in the first example of the Class E amplifier, L1 forms a parallel tuned circuit with the total shunt capacitance of *Cv* and the internal drain-source capacitance of *Cout*. Instead of following this with a low pass filter, it is followed by a series tuned resonant circuit, consisting of L2 and C2. The combination of the two tuned circuits is sufficient to ensure FCC compliance for harmonic attenuation.

From my experience, the difficulty with this approach is selecting the component values to effect a proper impedance match to the 50Ω load. It

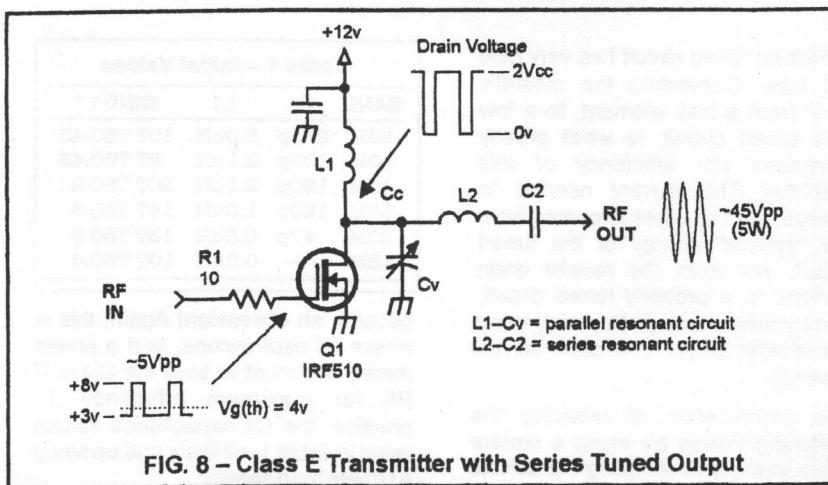

can be done with a little math, computer modeling, or experimentation, but again, due to the uncertainty of the actual IRF510 C_{out} value and resulting average output impedance, a fair amount of tweaking is required. Once the output impedance is properly transformed into 50Ω at the antenna, and L2-C2 tuned for resonance, the efficiency will be about 85%. However, with the L2-C2 series tuned element, it becomes rather narrow banded and efficiency drops when the frequency is moved about 10KHz. A variable capacitor across C2 will allow retuning upon frequency changes, although in practice, this is cumbersome for the way most of us prefer a no-tune QRP transmitter.

There are still other ways to implement the Class E amplifier, such as additional parallel or series tuned circuits on the output, or using impedance transformation schemes. It is an area worthy of further development by hams and QRPers. The main goal is to use the internal drain-source capacitance as part of the parallel tuned output circuit with the drain inductance. This will generally require some additional

capacitance between drain and ground, and some means to tune it to resonance. By doing so, the output capacitances are charged from the "flywheel effect" of the tuned circuit, that is, current from the drain inductor, not from the drain current. The later is wasted energy, which lowers the efficiency.

CLASS F QRP PA

The square wave *drain voltage* is rich in odd harmonics, predominantly the 3rd and 5th harmonics ($3f_0$ and $5f_0$). A sinewave with odd harmonics will be flattened at the peaks (at 90° and 270°), lowering the efficiency of the PA. Upon removing the odd harmonics, it will be a proper sinewave. In a typical QRP transmitter, the harmonic power is thrown away by the low pass filter. However, if one were to use this odd harmonic power in proper phase, the power could be added to the fundamental frequency to boost the output power. This would increase the efficiency of the amplifier.

This is the essence of Class F. The output network consists of odd harmonic peaking circuits in addition

to resonant circuits at the desired fundamental frequency. This forms the clean output sine wave, and the odd harmonic peaking adds a bit of power to the fundamental to increase PA efficiency.

Figure 9 shows one approach to accomplishing this. Component values are chosen such that L2-C2 is resonant at the 3rd harmonic, and L1-C1 and L3-C3 resonant at the fundamental frequency.

To analyze the circuit, consider the functions of these networks at different frequencies.

At the 3rd harmonic (3fo), L2-C2 is resonant, their reactances cancel out, offering little resistance to the 3fo voltage, passing the 3fo power to the L3-C3 network. L3-C3 will appear capacitive at 3fo, and will be charged with the 3fo power.

At the fundamental frequency (fo) L3-C3 is resonant, with a slight boost in power due to the voltage added to the network by the 3fo peaking circuit described above. At fo, L2-C2 (fr=3fo) will appear inductive, and the

value of C1 is selected to form a series resonant circuit at the transmit frequency with this inductance. Normally, C1 is a dc blocking capacitor, usually 0.1μF. In Class F, C1 will be a few hundred pF, depending upon the fo.

Obviously, it takes some math to figure out these values for the respective resonances, and to achieve the proper impedance transformation to a 50Ω load.

I have built several Class F Amplifiers, using an impedance network analyzer to verify the impedances, capacitance and inductance of all elements at fo, 2fo and 3fo. In spite of being properly tuned, I have never been able to reach an efficiency higher than what I've obtained with Class E. It is my opinion that the extreme complexity of Class F is not worth the effort over Class E at QRP levels. Class F is used in commercial 50kW AM transmitters, and at even higher powers for shortwave transmitters. Perhaps the extra 1-2% of efficiency is worth it for saving a kilowatt at these power levels, but is

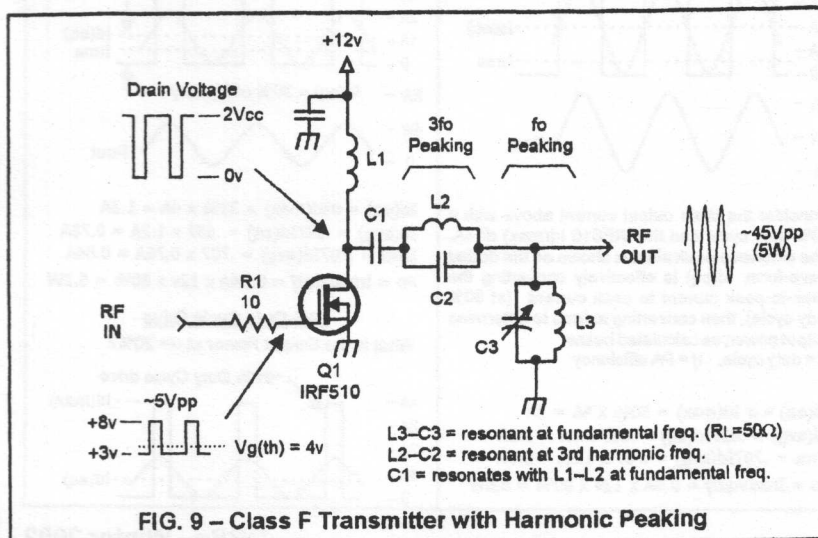

scarcely measurable at QRP powers.

None-the-less, Class F is a clever approach to increasing efficiency, and presented here for sake of completeness of the high efficiency modes.

Conclusion.

These switched mode PAs are ideal for QRP, in that the higher efficiency directly relates to lower battery drain. It is worthy of further development by QRPers, and the reason the theory has been presented in the first part of this article.

In Part 2 – a more technical approach to Class D/E/F will be presented, along with details of the gate input drive requirements and suitable driver stages, with actual oscilloscope waveforms. The IRF510 Data Sheet is also included in Part 2.

In Part 3 – two complete construction

projects: the NA5N Class D and Class E transmitters. Both include a high speed comparator, which converts the 50–500mVpp RF signal from a TX mixer into a square wave. It also includes the PWM circuitry for varying the pulse width for variable output power. Both are based on the IRF510, and yes, illustrations are based on *Manhattan Style construction*! These can be built and added to about any QRP transmitter for 5W output (and sometimes more!)

For those interested in Class D/E/F, I hope you have found the information in Part 1 informative. For those of you building such circuits, I would be interested in hearing of your success and approach.

72, Paul Harden, NA5N
 na5n@zianet.com
 pharden@nrao.edu

Appendix A – Pulse Width Modulation (PWM) or varying the duty cycle to control output power

50% Duty Cycle Drive

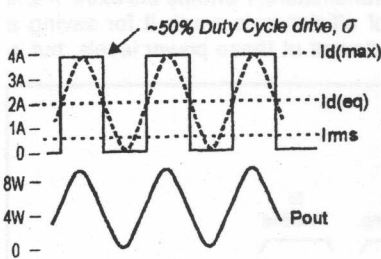

Consider the drain output current above with a 50% duty cycle and the IRF510 $I_d(max)$ of 4A. The sine wave equivalent is shown as the dotted wave-form. $I_d(eq)$ is effectively converting the peak-to-peak current to peak current (at 50% duty cycle), then converting to I_{rms} to determine output power, as calculated below.
 σ = duty cycle, η = PA efficiency

$I_d(eq) = \sigma I_d(max) = 50\% \times 4A = 2A$
 $I_d(avg) = .637 I_d(eq) = .637 \times 2A = 1.3A$
 $I_{rms} = .707 I_d(avg) = .707 \times 1.3A = 0.9A$
 $P_o = I_{rms} V_{dd} \eta = 0.9A \times 12v \times 80\% = 8.8W$

30% Duty Cycle Drive

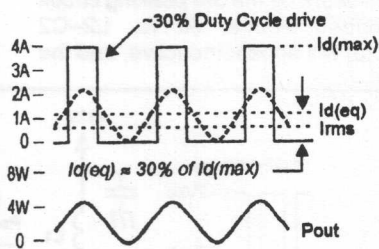

$I_d(eq) = \sigma I_d(max) = 30\% \times 4A = 1.2A$
 $I_d(avg) = .637 I_d(eq) = .637 \times 1.2A = 0.76A$
 $I_{rms} = .707 I_d(avg) = .707 \times 0.76A = 0.54A$
 $P_o = I_{rms} V_{dd} \eta = 0.54A \times 12v \times 80\% = 5.2W$

20% Duty Cycle Drive

What is the Output Power at $\sigma = 20\%$?

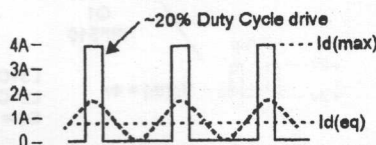

HF Vertical Travel Antenna - Updated:

Phil Salas - AD5X

Introduction

I've had a tremendous response to the portable antenna project published in the July 2002 QST. Since this antenna has been so popular, I've continued to improve and simplify it. In the last several months I've evolved the antenna from the original riser design, to a fiberglass design, and now to an aluminum tube design. This new design is lighter and more compact than the original antenna. It is also easier to build, and easier to find parts for.

As before, this new version of the Travel Antenna is designed for easy transport. It breaks down into

multiple mast and whip sections, an air-wound center loading coil section, and a small base support with no piece longer than 2-feet so it will easily fit into most suitcases. Yet the fully assembled antenna has a length in excess of 12-feet.

Gathering the parts:

The loading coil, half of a B&W 3027, is available from Surplus Sales of Nebraska.

(www.surplussales.com)

The 3/8" aluminum tubing is found in many hardware stores - or it can be ordered from Texas Towers \$25 min order at:

www.texastowers.com

The parts list is as follows:

Three 24" pieces of 3/8" diameter aluminum tubing (\$4.20/6' tube from Texas Towers)*

One 3/8" diameter wood dowel (\$1.28/36" @ Home Depot - only 5-1/2" needed)

One-half of a B&W 3027 coil (\$20 shipped from Surplus Sales of Nebraska)

One 72" telescoping antenna (\$4.99 @ Radio Shack 270-1408B/270-1408/27-1408)**

One 3/4 x 3/4 x 1/2" PVC-T (\$0.20 @ Home Depot)

One 3/4"-to-1/2" pvc adapter (\$0.50 ea @ Home Depot)

One 3/4" PVC Plug (\$0.89 ea @ True Value)

One 1/2x1/8-NPT brass adapter (\$1.20 @ True Value)

Eight 1/8-NPT brass couplings (\$0.95 ea @ Home Depot)

Four 1/8-NPT 0.7" all-thread nipples (\$0.75 ea @ Home Depot)

One 1/8-NPT 1" nipple (\$1 @ True Value)

One #8 wing-nut (\$0.34 @ True Value)

Three #8 x 1" brass screws (\$0.08 ea @ True Value)

Three #8 brass nuts (\$0.83/6 @ Home Depot)

Three #8 copper-plated steel split lock washers (\$0.05 ea @ True Value)

One 3/8x16 x 12" hex head carriage bolt, zinc plated (\$1.18 @ Home

Depot)

Two 3/8x16 nuts, zinc plated (\$0.83/6 @ Home Depot)

One 3/8 lockwasher, zinc plated (\$0.83/10 @ Home Depot)

Ten #6 stainless steel 3/8" sheet metal screws (\$0.07 ea @ True Value)

Six #6 stainless steel lock-washers (\$0.05 ea @ True Value)

One chassis-mount SO-239 coax connector (\$1.99 @ Radio Shack - RS278-201)

One #8 spade lug (Home Depot)

72 ft wire (Any gauge, insulated or not, for six 12-foot ground radials)

Six #8 x 1-1/2" brass wood screws (\$0.83/6 @ Home Depot)

* True Value and ACE Hardware stores have tubing areas with shorter pieces of aluminum and brass tubing. I found 3/8"OD x 3' aluminum tubes for \$2.50 each, and 3/8"OD x 3' brass tubes for \$4.50 each. So you can either go with two 3' tubes, or four 1-1/2' tubes if desired. Also, with brass tubes you can solder the couplings directly to the tubes. Make sure you adjust the brass couplings/nipples quantities as needed.

** This Radio Shack part is very confusing. All three of these numbers refer to the proper 6-section 72" whip. It seems to depend on the phase of the moon as to what the Radio Shack catalog, web site, and actual store inventory part has on it.

Aluminum Rod Preparation and Assembly:

See Figure 1 for the assembly details. In order for the couplings to fit over the aluminum tubes, the ends of the couplings that fit over the tubes must be reamed out with a 3/8" drill bit. To do this, first screw a 1/8-NPT coupling on each end of a 0.7" 1/8-NPT nipple. Use pliers and/or wrenches to screw these on tight. Next, grasp one of the couplings with a pair of vice-grips and ream out the opposite coupling with the 3/8" drill bit. Reverse, and ream out the other coupling. Now unscrew the couplings. One end will brake loose, and the other will stay tight in the remaining coupling. You'll now have a female and male end that will fit over

each end of the aluminum tubes. You will need four pairs of these male/female brass connectors: three pairs for the aluminum tubes and one pair for the loading coil assembly. If you'd like, you can solder the nipple/coupling assemblies together, however the nipple/coupling assembly tends to be very tightly secured. Finally, drill 9/64" clearance holes into the ends of the **three** coupling pairs that will slide over the aluminum tubes. These holes will pass the #6x3/8" stainless steel sheet metal screws that will hold the couplings to the aluminum tubes. Please note that the fourth coupling pair is used on the loading coil assembly and will be drilled and tapped for #8 brass machine screws.

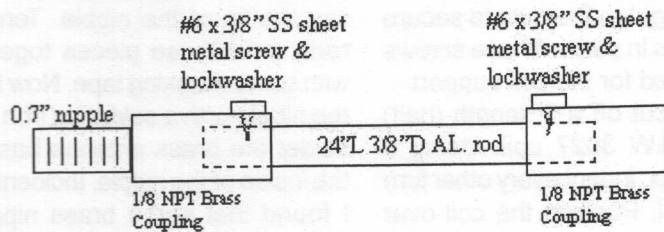

Figure 1 - Middle Sections, no coil (3 ea)

Next cut three two-foot sections of the 3/8" aluminum tubes with a hacksaw or tubing cutter. De-burr the tubing, and also slightly file the edges of the tubing to make it easier to push into the brass couplings. As shown in Figure 1, insert the male/female brass pairs just constructed over all three of the aluminum 24" tubes. This could be a tight fit, so you may need to tap the couplings in place with a hammer. Since brass and aluminum are significantly dissimilar metals, you may want to coat the aluminum tube ends with DeoxIt, Noalox or Penetrox to prevent possible corrosion, especially if the antenna will be outside for extended periods of time. To tap the couplings in place, insert the male/female coupling pairs over the 3/8" aluminum tubes as best you can. Then place the nipple-end

(male) on a piece of wood, and gently tap the opposite side of the rod (female coupling) with a hammer until the couplings are fully seated. Now, using the 9/64" clearance holes in the couplings as guide holes, drill 7/64" diameter holes through the aluminum tubes, and attach the risers to the aluminum tubes with the #6x3/8" sheet metal screws and lock-washers as shown in Figure 1.

Loading Coil Assembly:

Refer to Figure 2 for the loading coil section. Here, 1/8-NPT male/female coupling pairs are slid over a 3/8" diameter 5-1/2" long wood dowel. You will need to drill and tap a #8 threaded hole through one side of each of the 1/8-NPT brass couplings and into the wooden dowel as shown in Figure 2. Note that the screws are on opposite sides of the rod. Insert the

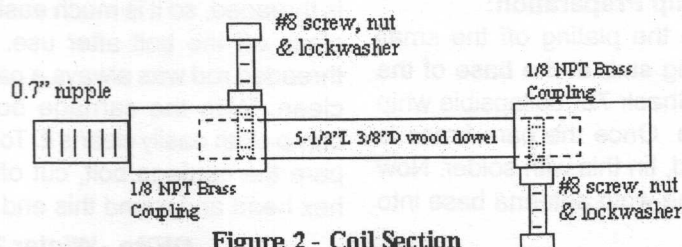

Figure 2 - Coil Section

two #8 x 1" brass screws through #8 nuts and lock washers as shown. Tighten the nuts to secure the screws in place. These screws will be used for the coil support.

Now cut off a 5" length (half) of the B&W 3027 coil. Using a screwdriver, indent every other turn of the coil. Position the coil over the screws such that the 1" long brass screw heads extend just above two adjacent turns on each end of the coil. Solder these two

the 1/8-NPT x 1" brass nipple such that the antenna base is just below the lip of the nipple. Temporarily hold these pieces together with some masking tape. Now heat the nipple with a soldering iron and solder the brass antenna base to the inside of the nipple. Incidentally, I found that some brass nipples were a little small on the inside to pass the collapsible whip. Nipples I purchased at True Value hardware cleared the whip, and nipples

1/8 NPT x 1" Nipple

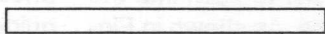
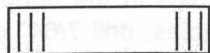

72" Collapsible Whip

Figure 3 – Collapsible whip assembly

turns at each end to the screw heads. On the end of the wood dowel coil form with the brass nipple (male end), solder a 6" piece of insulated wire terminated with an alligator clip.

For extended outdoor use, you may wish to treat the wood dowel with varnish, replace it with a piece of 3/8"D x 5-1/2"L fiberglass rod, or use the riser assembly as shown in the original QST article (July 2002).

Top Whip Preparation:

File the plating off the small mounting stub at the base of the Radio Shack 72" collapsible whip antenna. Once the bare brass is exposed, tin this with solder. Now insert the whip antenna base into

purchased at Home Depot didn't. If you can't find a nipple with a 0.275" ID, you can drill the nipple out with a 9/32" drill bit. Hold the nipple with a hefty pair of vice-grips when you do this and you won't have a problem!

Base Assembly:

In this design, I've used a 3/8x16 x 12" zinc plated hex head carriage bolt instead of the original brass threaded rod. Only about the last 1-1/2" of the carriage bolt is threaded, so it is much easier to clean off the bolt after use. The threaded rod was always a pain to clean. With the carriage bolt, a damp cloth easily cleans it. To prepare the carriage bolt, cut off the hex head and round this end with

a file. Referring to Figure 4, drill a 3/8" diameter hole into the 3/4" PVC plug used for the ground support carriage bolt. Cut off about half of the length of the 3/4" PVC plug to leave plenty of room inside the "T" for wiring, insert the carriage bolt threaded end into the plug, and secure with two 3/8x16 nuts and a lock washer as shown. I prefer soldering ground wire to the inter-

stainless steel sheet metal screws shown. However, the screws make changing the support assemble easy in case you want to have a second support assembly made from threaded rod for mounting onto a trailer mount, metal plate, etc.

Next, place the SO-239 temporarily over the 1/2" hole in the "T" and mark the location for the

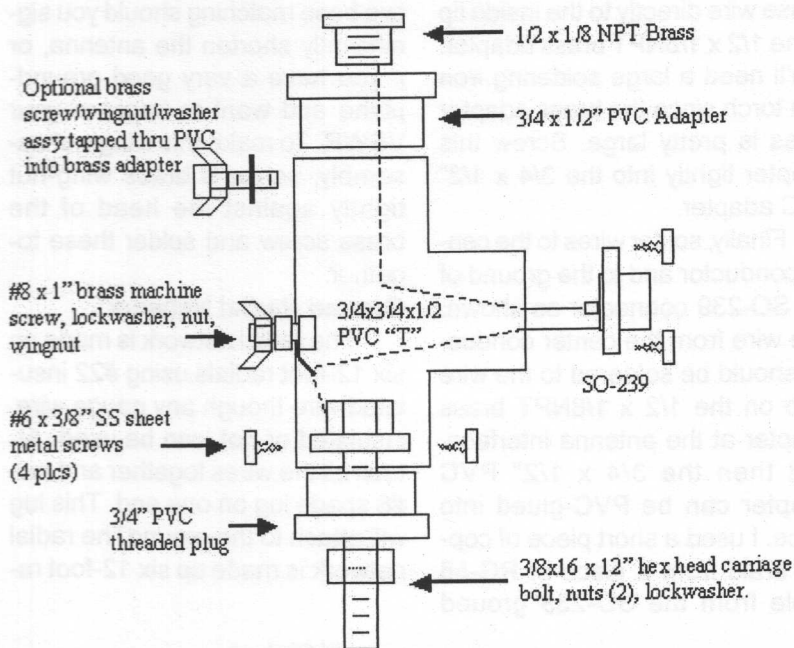

Figure 4 - Base Assembly

nal 3/8x16 nut as show. However, this is really not necessary, as the radials will provide the antenna ground - both RF and DC. If you wish, you can PVC-glye the plug in place instead of using the #6

two #6 x 3/8" long stainless steel machine screws that will hold it in place. You'll see that these holes will be right in the center of the PVC lip. Carefully drill two 1/16" holes at these points. Place the 3/4" PVC plug/spike assembly in the "T" and

drill two 1/16" diameter holes through the "T" and plug. Remove this assembly from the "T" and drill out these 1/16" holes in the "T" to 1/8". Also drill out two holes in the SO-239 connector to 1/8" since the holes are not large enough to pass the #6 x 3/8" sheet metal screws.

Next we'll prepare the antenna interface at the top of the base. First, cut off part of the 3/4 x 1/2" PVC adapter so as to leave additional room in the "T" for wiring. Solder a piece of #14 copper house wire directly to the inside lip of the 1/2 x 1/8NPT brass adapter. You'll need a large soldering iron or a torch since the brass adapter mass is pretty large. Screw this adapter tightly into the 3/4 x 1/2" PVC adapter.

Finally, solder wires to the center conductor and to the ground of the SO-239 connector as shown. The wire from the center conductor should be soldered to the wire stub on the 1/2 x 1/8NPT brass adapter at the antenna interface, and then the 3/4 x 1/2" PVC adapter can be PVC-glued into place. I used a short piece of copper braid from a piece of RG-58 cable from the SO-239 ground

(soldered directly to the SO-239 body) to the brass ground screw. You can solder the braid directly to the head of the brass ground screw. You can now complete the assembly of the base by inserting the PVC plug/12" carriage bolt assembly into the "T" and installing the #6 stainless steel sheet metal screws as shown in Figure 4. As you can see in Figure 4, I also made provisions for an optional wing-nut assembly in case you need to add capacitive or inductive base matching should you significantly shorten the antenna, or if you have a very good ground-plane and want to improve your VSWR. To make this wing-nut assembly, screw a brass wing-nut tightly against the head of the brass screw and solder these together.

Ground Radial Network:

The radial network is made up of six 12-foot radials using #22 insulated wire though any gauge wire, insulated or not, can be used. Attach all the wires together and to a #8 spade lug on one end. This lug will attach to the ground. The radial network is made up of six 12-foot ra-

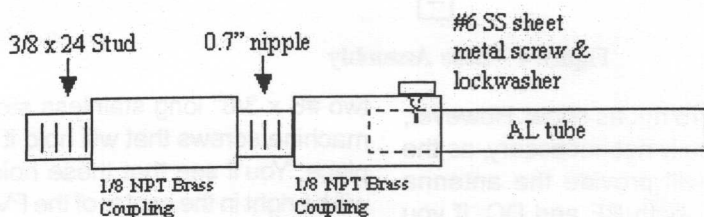

Figure 5 – Adapt to Standard 3/8x24 base

dials using #22 insulated wire though any gauge wire, insulated or not, can be used. Attach all the wires together and to a #8 spade lug on one end. This lug will attach to the ground screw on the base assembly. Roll up the six wires individually and hold them together with tie-wraps to minimize the time spent in unraveling the wires. On the outer end of each radial, solder on a 1-1/2" brass wood screw. These screws are pushed into the ground to help hold the radials in place. I put a blob of hot glue on the wire/screw interface to give it a little strain relief.

Antenna Assembly

To assemble the antenna, first screw two 24" aluminum rods together, and then screw these into the top of the base assembly. Push this base/rod assembly firmly into the ground, keeping it as vertical as possible. Next screw the remaining 24" aluminum rod, the loading coil, and telescoping whip assemblies together. Extend the telescoping whip. Screw this entire top assembly into the female end of the 24" aluminum tube that is available on the assembly currently pushed into the ground. Finger tight is all that is necessary for all brass fitting interconnections. Finally, extend the six radials, and attach the common end to the ground screw on the base assembly.

Antenna Set-up

To find a permanent coil tap for each band, start with 40 meters

and use an antenna analyzer to find the coil tap that gives the best VSWR. Mark this tap point. You may want multiple taps on 40 meters so as to cover both the CW and SSB portions of the band. Move to 30 meters and repeat. Repeat again for 20 and 17 meters.

For 15, 12 and 10 meters, the entire coil is shorted. The telescoping whip is adjusted for resonance. Use a permanent black marker pen to indicate the high band positions on the telescoping whip.

Now solder short pieces of wire to the tap points determined for all bands where the coil is used. From this point forward, you can just go back to these tap points, or re-adjust the top whip as necessary, and not have to worry about making VSWR measurements. You'll find that in all cases the VSWR should be under 1.5:1.

Guying and Mounting Options

This antenna is self-supporting in a no- to low-breeze environment. In many cases it may be necessary to guy the antenna. For effective guying, attach packing twine (3 pieces) around the bottom coil support brass coupler. Extend the twine and attach to tent stakes, nearby shrubs, etc. If you wish to bolt the antenna base directly to a trailer mount or plate, use a 3/8" threaded rod (brass or zinc-plated steel) as discussed earlier instead of the 12" carriage bolt "spike". In this case you should solder the

ground wire inside the "T" to the 3/8 x 16 nut as shown to ensure a good ground to whatever the base is mounted to.

Finally, you can easily make a 3/8x24 standard interface so that the antenna can be mounted on a standard 3/8 x 24 ham mount (most antenna mounts require a 3/8x24 stud on the antenna). It turns out that the 1/8-NPT thread is just a slightly tapered 3/8x24 thread. So, purchase a 3/8x24 bolt (your local hardware store again) and screw it tightly into a 1/8-NPT coupling. Cut off the head of the 3/8x24 bolt with a hack saw and file carefully so that the threads are OK for screwing into a 3/8x24 socket. You can now either screw this assembly onto the 1/8-NPT nipple on the bottom fiberglass rod section (See Figure 5), or screw the 3/8x24 bolt directly into the bottom 1/8-NPT coupling as shown in Figure 6 (if you'll never need the 1/8-NPT interface on the bottom antenna section). Now you can mount this antenna on any standard 3/8x24 antenna mount.

Conclusion

Due to the heavy interest in my portable antenna, I've made some changes which makes the antenna lighter, more compact, easier to fabricate, and also gives you more mounting options. You can also experiment with the antenna length – i.e. remove a section or two, use more or fewer sections, decrease or increase sections lengths, or place the loading coil in different positions. And how about 75-80 meters? You bought twice as much coil as you need, so build up a second coil assembly and put both coil assemblies at the base of the antenna. No need to indent or add an alligator clip to this coil. However, there is an efficiency penalty for base-loaded versus center-loaded antennas (but you must use base loading to reach 75-80 meters with this antenna). Also, you will need base capacitive loading to get the VSWR down on 75-80 meters. And finally, don't hesitate to make changes based on hardware availability. Try brass or copper tubing, or even wire

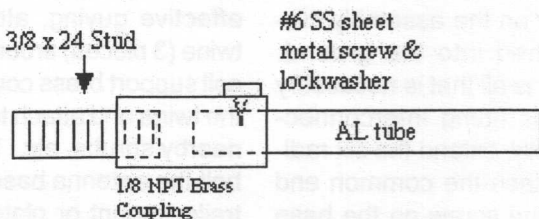

Figure 6 – Alternate Adapt to Standard 3/8x24 base

wrapped 3/8" fiberglass or wood dowel. Its fun to design antennas "on the fly" while standing in the plumbing section of your hardware store. This makes for interesting discussions with the clerks, however!

Phil Salas – AD5X – can be reached at ad5x@arrl.net if you have any questions or comments. This is an easy and fun antenna to build, and the total cost should be under \$60.

A Review of Short Antenna Design

Jim Pepper W6QIF

My experience with short vertical antennas started when ham radio was first allowed mobile operation on the HF bands in the early fifties. Up to that time, mobile operation was allowed only on the VHF and UHF bands. The very first day after the restriction was lifted I was on the air with a crude antenna on my car and contacted W6RJY (Floyd Becker) located about 2 miles from me. As time went on, many improvements in mobile antennas were made. A group of us would go to an open field near the Oakland airport to compare various antenna designs. We would move up to a given marker and each would transmit for a short period so home base stations could take a reading on their S meters. There were generally several stations giving reports. The antennas ranged from base loaded to top loaded to center loaded or combinations of these. There were some that had a loop going from the rear bumper to the front bumper. On the average, the center loaded antennas

gave the best efficiency and those with top capacitance loading with a center coil were the best. Corrections were made for power variations.

There were various types of top capacitance loading. Some were really bizarre. However, they couldn't be truly mobile because of their size.

SHORT VERTICAL ANTENNA DESIGN

For many hams it is sometimes difficult to string up a dipole for various reasons. If an efficient short antenna were available, this could satisfy many in this unhappy position. There are also occasions when one would like to operate in a field situation or on vacations, and finding a suitable set of trees for attaching a dipole is not easy, especially on a beach front area. So what is a good design for a short vertical antenna for other than mobile use? The principles are also applicable to mobile types of antennas with some restrictions.

To put up a quarter wave vertical for field operation on 40 meters is next to impossible unless you have a tree that is 33 ft high. And it still requires a good ground or counterpoise. A shortened version requires some sort of inductance to bring the system back to resonance because it is primarily a capacitive reactance. Where this inductance is placed can determine the efficiency of the system. The efficiency is defined as the radiation resistance (R_r) divided by the summation of $R_r+R_g+R_c$ where R_c is the rf coil resistance and R_g the ground resistance. R_r depends on the length of the antenna as well as the frequency of operation, R_c depends on the coil "Q" and R_g , the ground system, which depends on the ground conductivity and/or by an artificial surface equivalent to the ground in the form of multiple radials.

The radiation resistance of a short antenna (8 foot) at 7 MHz is quite low, in the order of 1 to 6 ohms depending on the type, therefore to keep the efficiency up, the losses from R_c and R_g must be minimized.

SWR MEASUREMENT (1)

A low SWR measurement at the base of the antenna is usually considered an indication of the fact that the antenna is doing a good job of being efficient. This is not necessarily true. For example, if the reading is a SWR of 1:1 is obtained with no line matching transformer

and the $SWR = Z_o/R_t$ where Z_o is the transmission line impedance, then R_t would then equal 50 ohms. $R_t = Z_o/SWR$ Thus, with an SWR of 1:1 with no matching transformer and the R_r for an 8 ft base loaded antenna being about 2 ohms at 7MHz, the efficiency would be $2/50$ or 4%. Not very efficient. But a more efficient antenna would record a higher SWR reading when connected to a 50 ohm line with no matching. For example, a vertical with a radiation resistance (R_r) of 4 ohms and no other losses would have an SWR of 12.5:1. $SWR = 50/4 = 12.5$ $R_r/R_t = 4/4 = 1 \times 100$ or 100%. It would be 100% efficient but would require a matching network at the base to reduce the SWR to 1:1. (4 ohms to 50 ohms).

In any case, it is most likely that a matching network will be required at the base on all short antennas to improve the efficiency. So one can see that having a low SWR doesn't mean you have an efficient radiator although it may allow the transmitter to apply power to the antenna. It probably means that your losses from the coil and ground system have added up to give you a good match.

A high SWR can be ignored if the transmission line is very short as in the case of a mobile system. The mismatch can be corrected at the transmitter. However, with a field operation, it not wise to sit close to the radiation system therefore matching would be required. But even with matching you are still lim-

ited by the radiation resistance for the performance of the antenna.

SHORT VERTICAL ANTENNA DESIGN

Good HF radiating antennas come in various forms and I am sure you are well aware of the different types. I want to discuss one special type of radiator, that of a short vertical antenna, short meaning less than $1/6$ wave in length. The vertical antenna in this discussion is for the 40 meter band but could be scaled to other bands. As a matter of fact the design I will describe will cover both the 40 and 30 meter bands with a small modification. The overall height is approximately 8 feet.

There are a number of antennas that fit this category of short antennas, both commercially built as well home brew. So what are the considerations on designing such an antenna if you want to try building one of your own to obtain maximum efficiency?

One way to look at any antenna is that it must be a resonant circuit to give maximum efficiency. Note, I said maximum efficiency. It is possible to get any length of wire to radiate if proper matching is provided to the power source but may have very low efficiency depending on the length of the wire and frequency of operation.

A BASIC ANTENNA FIG 1

Let us consider an LC tuned circuit and open up the capacitor

plates so they are far apart. If the capacitance plates are increased by making them larger in physical size the system can still be resonated to the desired frequency. Thus we have the basis of a radiating antenna system. There is an exchange of RF voltage and currents between the two plates setting up a dielectric field that will produce radiation. With the vertical antenna, the field is set up between the capacitance of the antenna rod and the conductivity of the ground system that returns the current back to the source. This is called the induction field and varies as the inverse square of the distance from the source. How much is returned depends on the losses in the ground system. On a vertical antenna, the ground system can consist of a single wire some times called a counterpoise, a large number of wires called radials, or even a wire screen. It is vital that this return path be provided to produce a resonant system. It is also aided by the conductivity of the earth itself.

Now, in the case of a short antenna, how long and how many of these wires are needed? Let us go back to the concept of the LC circuit. If we had a capacitor that had a large plate on one side and a small plate on the other, the actual capacitance would be predominately determined by the smaller plate. This turns out to be the case with a short vertical antenna.(2) It does not help much to have a large

ground plane when the source is a small capacitance. In fact I found a ground plane longer than the height of the antenna did not improve the efficiency to any meaningful extent. In addition, because the primary induction field decreases as the inverse square of the distance, the effect on the return is greatly diminished the further out it goes. This is not the case of the radiated field which is lost in space and never returns to the source. This field is influenced by the earth ground system and thus determines what the effectiveness of the radiated signal has after it leaves the antenna.

As previously stated, the short vertical is seen as a capacitive reactance and therefore, to bring it to resonance, an inductance must be added. To do this, a coil must be placed in series with the antenna rod or wire. Such a coil, however, produces a loss in the system due to the coil resistance at rf frequencies. An alternative is to increase the capacitance and to reduce the capacitive reactance, thus requiring less inductance to bring the system into resonance. To add capacitance, the size of the vertical rod's diameter provides some influence, but going from a wire to 1/8 inch diameter doesn't have much effect. However, going from 1/8 to 1/2 inch gives about 20 percent increase in capacitance. The capacitive losses can be kept much smaller than inductive losses. I am not referring to the

ground losses which must be dealt with separately. So where are the losses in a short vertical radiator? We have the radiation resistance (R_r) loss but we want to maximize this because this is the power lost to radiation, our primary goal. R_r is dependent on the physical length of the vertical as well as the frequency of operation. Other losses we want to keep to a minimum because these losses reduce the efficiency of the antenna.

As previously stated, the two major sources of loss are the coil loss and the ground loss and the system is basically an LC system thus we want to keep the inductance small and the capacitance large. There are two ways to increase the capacitance. Increase the diameter of the radiating rod and/or use top loading capacitance which also effectively increases the length of the antenna and at the same time increases the R_r of the antenna. Or do both. The coil loss can be identified by a factor called the "Q" of the coil. The Q is defined by the ratio of the coil impedance divided by the RF resistance of the wire of the coil at the frequency of operation. Typically we want to achieve a Q as high as possible to keep this loss to a minimum. What are the factors that effect the Q of a coil? There are a number of them. First is the diameter of the wire and the material of the wire. The larger the better but obviously there are limitations to this.

The material should be one of good electrical conductivity. (Note: The RF currents only travel on the outer surface of the wire, thus the core can be open as in the case of tubing.) Another factor is the shape of the coil. The larger the diameter of coil, the higher the Q. Again there are limitations on this. The ratio of the length to diameter has an effect on the Q. The diameter should be greater than twice the length of the coil although this is not a strict rule, but it should not go to far from this value to achieve a high Q (3).

Other factors that effect the Q are: 1. the proximity of a metal object close to the coil. They should be kept at least a coil radius away from the coil. 2. The material of the coil form should be low loss such as plexiglass, or better, air. And finally the distance between adjacent wires on the coil. The capacitance effect between turns will lower the Q. As a rule of thumb, the spacing between turns should be about the diameter of the wire.

Since the inductance is inversely proportional to the square of the diameter of the coil, if you increase the diameter by 2, the number of turns is reduced by 4. The reduction in the number of turns reduces the resistance loss of the coil for a given size of wire thus aids in increasing the Q of the coil. It has been shown that, if the inductance is placed in about the middle of the vertical, it results in a higher

radiation resistance than using base loading.(4) Most of the current that produces radiation mainly lies below the coil and thus it is best to keep this as long as possible. There is radiating current above the coil as well, but it drops off radically as it approaches the end of the antenna. The problem with putting the coil in the middle is that it requires more inductance than with base loading since the capacitance above the coil, to the ground plane, is now reduced. The capacitance above the coil is the source for primarily producing a resonant system. This means greater care must be employed to keep the Q of the coil high to overcome this loss due to the increase in inductance.

Of course the best place for the coil would be at the top of the antenna giving the maximum region for the radiation current. This requires an even larger coil and, of necessity, requires a capacitance to complete the circuit. The answer is known as top loading using a "capacitance hat" consisting of either a large disc, a number of horizontal wires in a spoke arrangement or other bizarre methods.

So we have one method of increasing the efficiency, so what other means can we use? Lets look at the ground loss. If we look at this area as the current return path, then, if we provide a large surface instead of a multiple number of wires, we can accomplish the same thing. I found an answer in a prod-

B is LOWER EMT SECTION AT BOTTOM OF MAST
 B' is TOP EMT SECTION AT MAST TOP

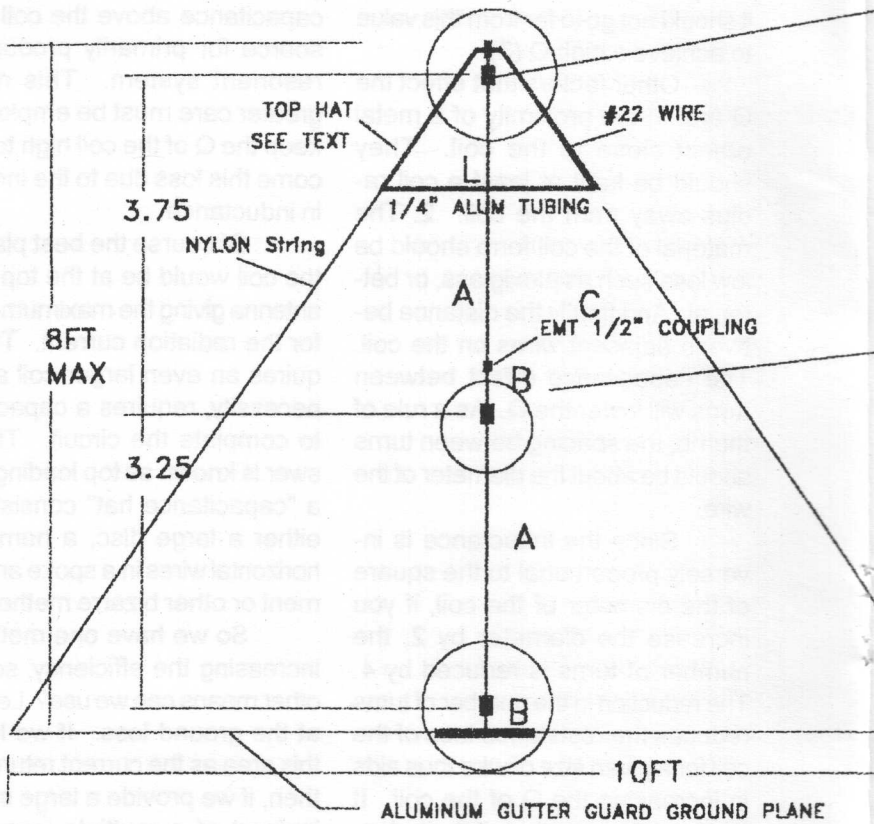
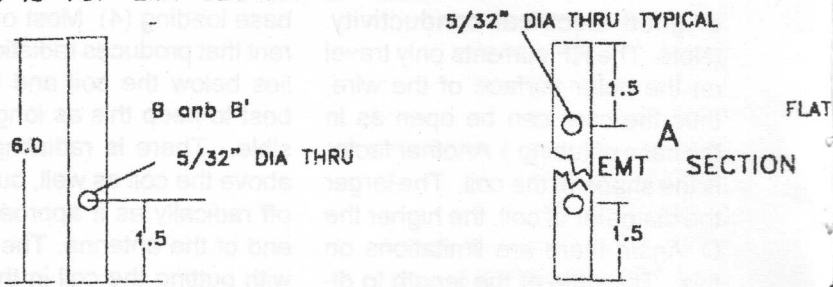
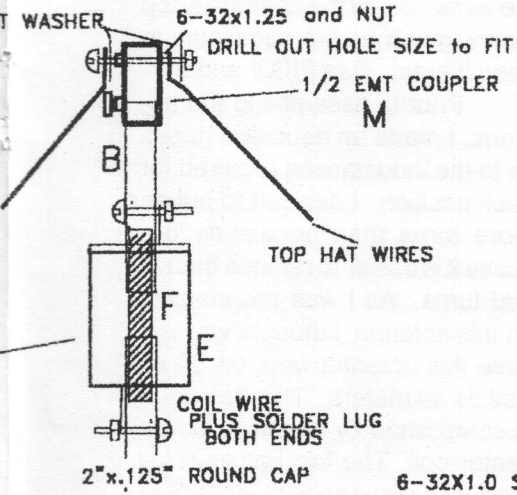

FIG 1

QRpp - Winter 2002

FIG 2

J and K



H and K

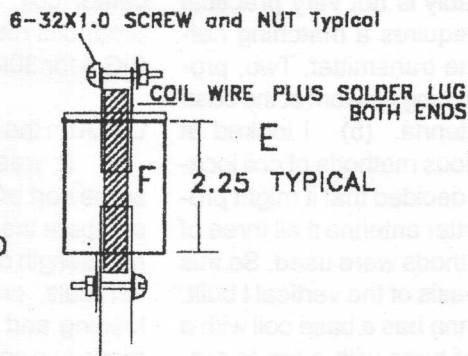

PLEXIGLASS ROD

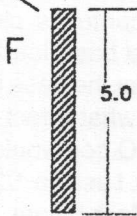

GUTTER GUARD END BRACKET
8 REQUIRED

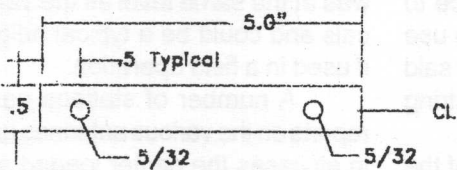

uct supplied by hardware stores that is used for covering rain gutters to keep out leaves. The material is an aluminum mesh 6 inches in width in a roll 20 feet long. Results using this material proved very effective as I will show later. SEE TABLE 1 I used 4 lengths 5 ft long forming a cross around the base of the antenna. Another loss source is matching this antennas resistance to the transmission line. (One to ten ohms for short antennas vs 50 ohms the transmission line impedance). There are several methods that can be used. One, keep the transmission line very short, but this probably is not very practical and still requires a matching network at the transmitter. Two, provide a matching network at the base of the antenna. (5) I looked at these various methods of coil locations and decided that it might produce a better antenna if all three of these methods were used. So this was the basis of the vertical I built. The antenna has a base coil with a number of turns with a tap to provide matching to the 50 ohm coax. The mid coil is about 1/2 up from the base and at the top is located an additional coil. The overall height of the antenna is 8 feet. So what to do about the top loading? The top coil requires a capacitance to make it effective. I decided to use part of the four guy lines (note I said lines not wires. I used nylon string for the lines.)

The upper 2 foot part of the guy line is actually wire used as

part of the capacitance hat. The hat is completed by using a ring made from 1/4 aluminum tubing tied to the wires. Since the antenna is top heavy, guy lines are necessary to keep it erect. See FIG 1 and 2

Prior to assembling the antenna, I made an educated guess as to the inductances required for each position. I decided to put on more turns than necessary because it is easier to remove than to add turns. As I was progressing on this antenna, I thought why not have this antenna work on 30 as well as 40 meters. This has been accomplished by shorting out the center coil. The top hat and coil produces resonance at 30 M. See FIG 4 for 30M matching.

DATA on the 8 FOOT VERTICAL

It was important to have some sort of reference antenna to compare the short verticals for signal strength differences. (I made two verticals, one center is plus top loading and one base loaded). I made two coils for the base loaded antenna to see what effect a high Q coil vs a low Q coil would have on the efficiency. I used a 1/2 wave dipole at a 15 foot height as the reference. Although this was not considered to be a good height it was at the same level as the verticals and could be a typical height if used in a field operation.

A number of stations gave reports on the various antennas and in all cases the center loaded antenna (CLA) was equivalent or bet-

ter than the dipole and the base loaded was about 2S units lower. Instantaneous switching from one antenna to the other reduced the probability of atmospheric changes that would effect the accuracy of data. In some cases, the land line was used to relay the information so there was no time lapse from one position to another. It was difficult to determine absolute differences due to the signals fading. The peak readings were used.

The best DX to date is Monroe, Louisiana with an S4 reading while running 20 watts. I have also worked Colorado, Washington, Nevada and Mexico with good reports. All better than or equal to S7 with 20 watts except Louisiana.

The use of the wire mesh ground plane indicated a higher level of efficiency than the use of wires. This information was obtained by the higher SWR reading without using a matching section at the base of the antenna. The higher the SWR reading indicated the lower loss in the overall system. One can use this method to determine any changes on design to determine whether the efficiency has been modified. Of course, a base matching section must be used to obtain the benefits of the improved efficiency. (I used a MFJ antenna analyzer to make SWR measurements. Measurements were taken at the base of the antennas.) Based on other data that indicated the radiation resistance of these types of verticals with a

height of 8 feet at 7MHz, I used the value of 2 ohms for the base loaded antenna and conservative 6 ohms for the center plus top loaded system. A value of 4 is used for a center loaded only antenna with out top loading. The calculated efficiency was approximately 8% for the base loaded antenna and approximately 30% for the centerloaded plus top loading unit.

The bandwidth, to where the SWR was greater than 2.0, was about 700kHz for the center loaded antenna and about 500 kHz for the base loaded system.

EFFICIENCY CHECKING

If you want to check the efficiency of the antenna you must disconnect the matching transformer and connect the 50 ohm line center conductor directly to the base of the antenna rod. Now read the SWR. It will not be at the 7MHz point but higher and will read at least 2 or above. The higher the better. Take this value and divide it into 50 which gives you the R_t value. Divide the R_r by this value and multiply by 100 to give the percentage efficiency.

ANTENNA RESULTS

(No tests have been made as yet as to its performance on 30 meters)

DATA TAKEN ON THE ANTENNA

Various configurations were made on the antenna during its development. The efficiencies for

these configurations are tabulated in Table 1

Other interesting data that was found

1: lengthening the ground plane using the 5" aluminum wire screen to twice the length had no appreciable effect on the efficiency. The same was true for the wire grounds.

2: the signal strength of received signals were about 2 S units higher on the CLA. However, signals coming from long distances were about the same.

3: for proper matching of the BLA, I used a variable capacitor to provide a 1:1 match. It was approximately 300pF connected from the feed point to ground.

4: the supposed higher Q coil for the BLA did not increase the efficiency as much as I expected. This was probably due to the denominator effect of the ground loss as compared to the improvement in the reduction of the coil loss.

5: wire type of ground plane was not as effective as the 5" mesh screen. However, the 8 wires were almost as effective.

6: going from 4 wires to 8 on the BLA gave approximately 50% improvement in the efficiency going from 6 to 9%.

7: going from 4 to 8 wires on the CLA gave only a small improvement. From 17 to 23% when no screen was used.

CONCLUSIONS

1: The CLA antenna gave a better performance than the base loaded antenna, however the extra work in its construction may not be considered enough gain (1 to 2 S units) to implement the system. For those who like to experiment with antennas, it might be worthwhile to see if they can improve on the system.

2: A short vertical can produce good results if you have a good ground system. The ground system does not need to be long (approximately the height of the antenna in length) but the number of wires will improve its efficiency up to a certain point. There is a point of diminishing returns.

3: Improving the Q of the coil of the base loaded antenna makes little change due to the denominator loss in the ground system and the low radiation resistance.

4: An antenna matching network at the base of the antenna is a must if the transmission line is long (greater than 1/16 wave length) to achieve maximum efficiency. If less, the matching can be done at the transmitter.

For those who have a limited space for a 40/30 meter antenna, this could be an ideal solution. It only takes up a floor space of 25 sq ft (5x5).

References:

1. Efficiency of Short Antennas, Stan Gibilisco W1GV/4 Ham Radio September 1982 page 18
2. Radial Systems for Ground

Mounted Antennas Vertical Antenna Classics ARRL publication page 107, Jerry Servick W2FMI Also April 1978 QST

3. Losses in Air coils at Radio Frequencies, Terman Radio Engineer's Handbook page 74

4. Evolution of the Short Top Loaded Vertical, C Michaels W7XC page 86 ARRL Vertical Antenna Classics, First edition Also March 1990 QST

5: ARRL Handbook chapter 33 Sixty six edition

I wish to thank Dave Meacham W6EMD for his perusal and comments in helping write this article. Also to Floyd Becker W6RJY, Santa Rosa, for giving the listening and signal reports on the various antennas and Jack Cash, W6ORR, who gave me signal reports from his location about a 1 mile from my QTH.

I would appreciate any comments you may have on this subject. Jim Pepper W6QIF@i.x.netcom.com

CONSTRUCTION DETAILS

The basic configuration of the whole antenna is shown in Fig 1 and Table 2. Three coils are to be constructed, one for the base matching, one for the center coil and one for the top loading coil. All three are wound on 2"D by 3"L with a wall thickness of 0.125 inches plexiglass tubing (available from TAP plastics). The core for the coil forms is made from 5/8d plexiglass solid rod.

The mast material is 1/2 inch EMT metallic tubing which has an inside diameter of .622 or slightly smaller than the rod size of .625. I found by using a 1/2 inch round file that the opening could be enlarged sufficiently to take the slightly larger diameter of the rod. It should be a snug but not too tight because you may want to remove it during some construction operation. The rod extends inside the EMT about 1.5 inches. The holes drilled on the coil forms are identical for each coil. The wire is fed through a hole in the cap and attached to the screw on the EMT using a solder lug See Fig 2 and 3. The other end of the coil attaches to the lower section of the EMT. The upper part of the EMT, from the center coil to the top loading section, is broken in two sections to allow easy transportation of the unit. An EMT coupling is used to attach the two section together.

TOP HAT

The top hat is made from a 10 ft length of 1/4" aluminum tubing. Mark off 4 points 30 inches apart to indicate where the wires will connect to the tubing. Form the tubing into a 3 foot diameter circle. The open ends are connected together using a 1/4x1/4 compression union. (ACE hardware #43008) The tubing is connected to the antenna mast by 4 #22AWG enamel wires. Each leg is 2 ft long but is made from one piece that is 4 ft long. The center point of this

wire has its enamel removed. This center is later wrapped around the screw located on the EMT section at the top of the antenna. I used an EMT coupler for this purpose to attach the hat to the top of the mast. See FIG 2 The wires are attached to the aluminum tubing by homebrew aluminum straps bent around the tubing and held in place by a nut and screw. This completes the making of the hat. From these four points the nylon guy lines are attached. I used a product used on leashes that clamp on to a dog collar which allows a quick disconnect.

WINDING the COILS See Fig 2 and 3

The each coil is wound with ten turns of #18 enamel coated wire. 10 Feet per coil. A pig tail is left on each end of the coil of 1.5 inches to allow attaching to the mast. I used a solder lug for this purpose. Mount the solder lugs on the mast and then attach the coil leads centering the coil in the middle of the opening of the plexiglass insulator.

I found the best way to wind the coils is put the wire thru the hole on the coil form and attach the other end of the wire to some non movable object. Pull the wire taut and start winding the coil. Wind the coil such that it covers the total form with proper spacing. Put the other end thru the other end of the form.

I used scotch tape to hold the wire spacing temporarily in place. Using DUCO Cement (Tm), I secured each wire in place. I did only

a few wires at a time. I also left the last 3 wires un cemented to allow further adjustment for proper frequency range.

It is possible to move the wire spacing before the cement completely dries to correct for bad spacing. It doesn't have to be perfect it just makes a nicer looking construction.

MOUNTING the COILS See Fig 2 and 3

The coils are mounted using a plexiglass cap obtained from TAP Plastics. It is a 2" diameter by 1/16 piece that will be cemented to one end of the coil with DUCO cement. The cap is modified by drilling a 0.7 dia hole at its center. I used a pilot hole of 3/8" which was large enough to allow a tapered reamer to enlarge the hole. The hole should be a tight fit over the EMT which is 0.706 in diameter. An additional hole for the wire feed thru is required as shown in Fig 3.

The wired coil form, with wires coming out top and bottom, is now ready to mount to the EMT mast. The two ends have the enamel removed and attached to a solder lug. The coils are then placed on the mast and attached as shown in Fig 2 using 6@32 screws.

BASE COIL Modification See Fig 4

To allow proper matching to the 50 ohm coax, a tap is made on the base coil. The tap is located

two turns from the bottom end for the coax. The clip lead for the center of the coax connector is connected to this point. In addition, to properly match the 30 meter operation, an additional wire is connected to a tap per Fig 4. This tap is 4 turns up from the bottom. This wire is connected to the top of the base coil for 30 meter operation.

GROUND SYSTEM

The following method is how I connected the base of the antenna to the ground system. It is a suggested method and you can modify it to fit your requirements. I mounted the mast onto a 6"x12"x1/4" aluminum plate using a 1/2" EMT box connector. This allows the antenna to be removed from the plate. The SO239 connector is mounted to the plate with screws using a L shaped bracket.

A wire from the SO239 center pin attaches to the base coil by an alligator clip on the end of the wire. This allows the antenna to be removed from the base without unscrewing the SO239 from the plate. The 30M connector wire also uses an alligator clip for easy 30M modification.

The 6" wire mesh is attached to the aluminum plate by 1"x6"x1/8" bar stock which is screwed to the plate. The wire mesh is placed under the bar stock and then held in place by the bars. For transportation of the antenna, the ground wire mesh can be rolled up and held in the roll position by clothes pins

while still attached to the plate.

30 METER OPERATION (If you are only interested in 40M operation skip this next step.)

The 30 meter antenna is the first to be adjusted for proper frequency operation. The antenna can be converted to 30 M by shorting out the center loading coil. See Fig 4 for the proper load matching connection for this band. Using the MFJ analyzer at the base of the antenna, I tuned for minimum SWR. If the frequency was too low, some turns must be removed from the top coil. If you left some turns on this coil without being cemented down, you can move them further apart to see if this gets you into the band. If it is on the high side, try moving the turns together. If this isn't sufficient, I attached a small length clip lead to the 1/4" top hat tubing (any spot) and see its effect. A one foot clip lead will change the frequency by 150kHz. Trim to give proper frequency.

40 METER OPERATION

Next remove the jumper from the center coil and set the signal source to the portion of the 40 meter band where you normally operate. Re set the matching transformer connection for 40 M operation. Check the SWR at the desired frequency of operation. If the SWR is above 2, you will have to adjust the center coil windings. Locate where it drops down to 1:1 and make the corresponding adjustments. You should have left a few turns at the

top or bottom of the coil to make this adjustment.

The antenna is now ready for on the air testing.

FIG 1

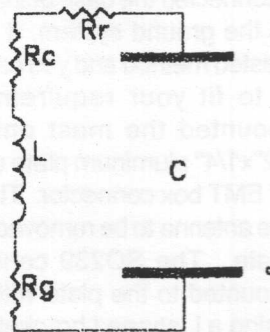
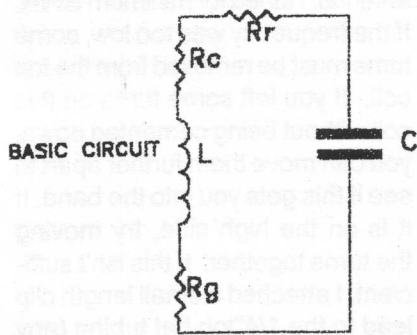

FIG 3

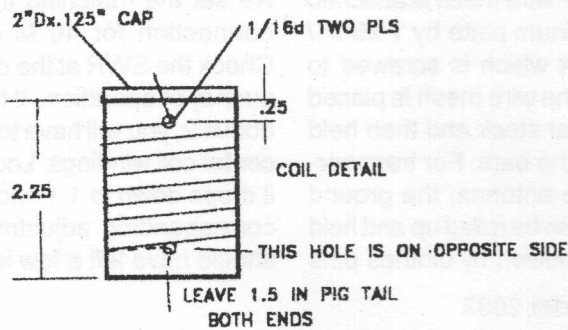
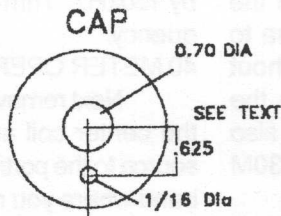

FIG 4

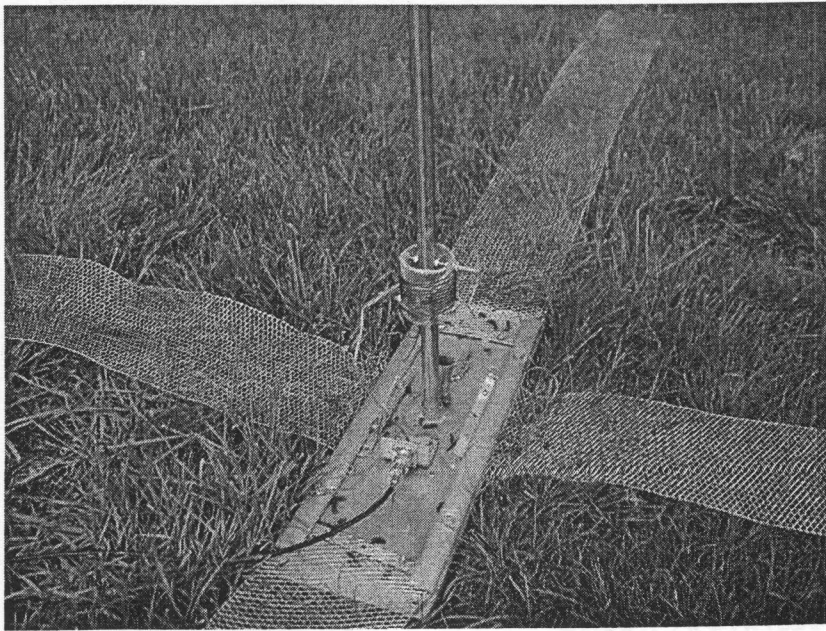
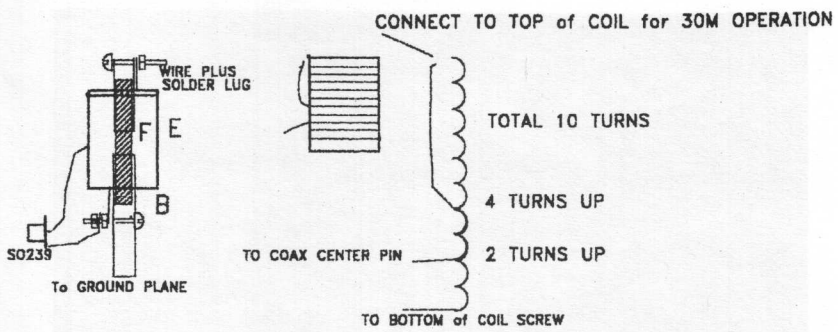
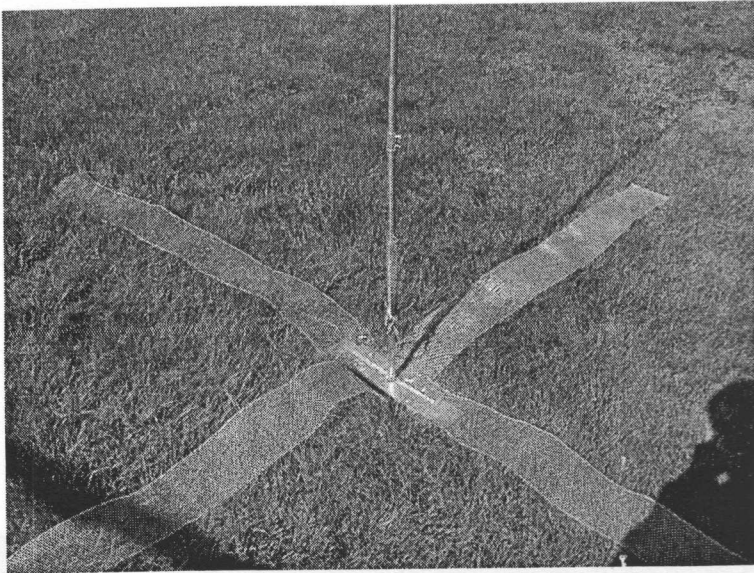

Photo 1 Base Plate



Base Loaded Antenna

TABLE 1

ANTENNA EFFICIENCY BASE LOADED	1" DIA. COIL EFF. % *	3" DIA. COIL EFF. % *
4 #22 AWG 8 FT. LONG	6	6
8 #22 AWG 8 FT. LONG	8	8
4 5' SCREEN 5 FT. LONG	11	11
8 #22 WIRE + 4 SCREENS	12	12

* RADIATION RESISTANCE 2 OHMS FOR BASE LOADED ANTENNA
8 FEET LONG @ 7 MHz.

CENTER + TOPLOADED	EFF. %
4 #22 AWG 8 FT. LONG	17
8 #22 AWG 8 FT. LONG	23
4 5' SCREEN 5 FT. LONG	31
8 #22 WIRE + 4 SCREENS	32

* RADIATION RESISTANCE 6 OHMS FOR CENTER-TOP LOADED AN-
TENNA 8 FEET LONG @ 7 MHz.

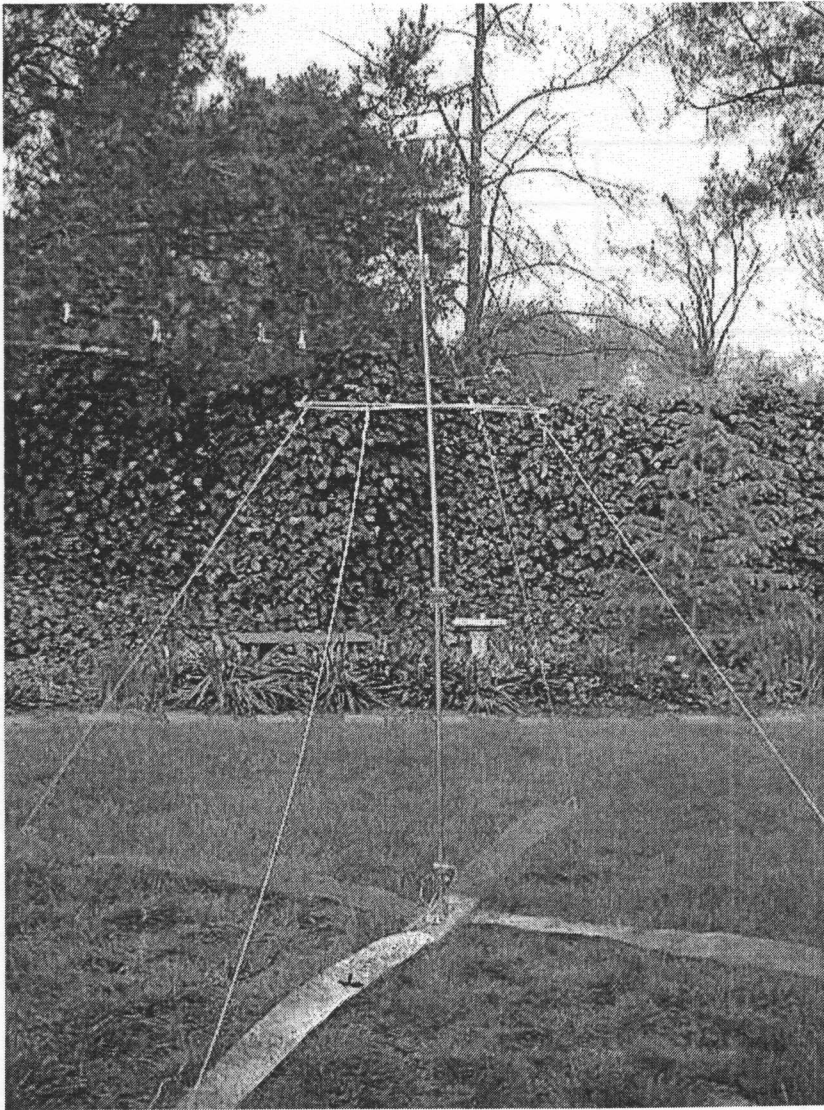

Center Loaded Antenna

TABLE 2

A	2 LENGTHS 1/2" EMT 3.25FT L
B	3 LENGTHS 1/2" EMT 6" L
C	1 PC 1/2 EMT COUPLER
D	3PCS 2"Dx1/16 PLEXIGLASS
E	2Dx2.25L PLEXIGLASS TUBING 1/8" WALL TH 3 PCS
F	3PCS .625DIA PLEXIGLASS ROD 5" L
G	8PCS 6-32 FLAT WASHERS
H	6PCS 6-32 MACHINE SCREW 1.0L
J	6-32 MACHINE SCREW 1.25L
K	7PCS 6-32 NUTS
L	10FT Aluminum 1/4" TUBING
M	1 PC 1/2 EMT COUPLER
N	40 FT #18 E.C COPPER WIRE
O	5"x20FT Aluminum GUTTER SCREEN ACE HARDWARE PRODUCT
P	1/2"x 1/16" AL FLAT BAR

Note: Only the lower section A has holes on both ends.

USING AN OSCILLOSCOPE AND LOAD RESISTOR TO ESTIMATE R-F POWER

by George Baker, W5YR

Measuring the output power of a transmitter, especially a QRP rig, can be difficult task. Conventional "wattmeters" usually lack accuracy at power levels of 5 watts and below. Even the popular Bird 43 goes down only to 50 watts full scale with an accuracy of +/- 2.5 watts. R-F power meters from major test equipment manufacturers are prohibitively expensive overkill for most amateur applications. Similarly, r-f voltmeters that work up to several hundred Megahertz are available and, while very convenient to use, are costly, present an ongoing calibration problem, and are usually more than is required for the purpose.

The QRPer who possesses an oscilloscope, or access to one, and a good 50 ohm load resistor has the basic equipment required to make useful estimates of QRP transmitter power output. The scope should have an upper frequency response of at least twice the operating frequency and a means for calibrating the vertical input channel. Most scopes provide an internal calibration signal that is adequate for the purpose. Load resistors can range from small non-inductive resistors of adequate power rating to dedicated artificial loads such as the

venerable Heathkit Cantenna and its modern-day counterparts.

Following is a brief description of the procedure one would use to measure the output power from a transmitter using a scope and load resistor. A numerical example is included to summarize and illustrate the procedure.

PROCEDURE

First, make sure that the output signal from the transmitter is a sine wave - no harmonics or waveform irregularities to complicate things. No modulation, either - just a steady continuous sine wave signal with no peak amplitude changes with time.

Second, make sure that the signal is present and constant long enough to get it synched up on a scope and the amplitude observed. Note that the scope must have a high enough frequency response to show the transmitter signal accurately. Don't try to measure a 10 meter signal with a 5 MHz scope. To avoid heating the load resistor and causing its resistance to change, do not apply power for more than several seconds at a time.

Third, assume that the scope vertical amplifier is properly calibrated. Most scopes have a cali-

brator signal brought out on the front panel. Use that to verify the control setting. If the probe is either X1 or X10, take that into account when figuring the vertical gain control setting in volts per division of the scope graticule - that graph on the CRT face.

With the signal present on the screen and the gain set for a convenient signal amplitude - try for about two-thirds of the screen height - measure the peak to peak amplitude of the sine wave in scope graph division and convert this to volts. Call this V_{p-p} .

Divide this by two to get the peak voltage V_p , and then multiply the peak voltage V_p by 0.707 to get the rms voltage V_{rms} .

Square V_{rms} and divide by the resistance of the load across which the voltage is being measured.

The result is the power (in watts) being delivered to the load resistance (in ohms) with the observed voltage (in r-f volts) across it.

A formula would look like:

$$P = (V_{rms})^2/R.$$

EXAMPLE

First, get the scope all set up and calibrate the vertical channel, etc. for five volts per vertical division. That means that the distance between the horizontal lines on the graph on the face of the scope represents a voltage change of 5 volts. Since the load resistance is fairly low, using a "X1" probe or a probe

with a X1 setting saves a little mental arithmetic and won't load the circuit and affect the results.

Next, connect the transmitter output to the load resistance which has been previously measured and found to be 47 ohms. Use the shortest possible connection to minimize the errors introduced by the feedline, since if the load resistance doesn't match the characteristic impedance of the feedline, and provide the required transmitter load, there will be reflections which can change the scope waveform. This may sound like a minor effect, but it can have a major impact on accuracy, regardless of the method used.

Make sure that the resistor can dissipate the transmitter power for at least several seconds without overheating and changing resistance while you read the scope pattern. Keep the transmitter on no longer than absolutely necessary to read the pattern. Otherwise, the resistor will heat up and change its value. This can seriously affect the accuracy of the measurement by this or any other procedure.

With the transmitter on, quickly but carefully measure the height on the scope graph from a negative peak to a positive peak. This might be something like 6.8 divisions on the scope graph. Knowing that we have the scope set for 5 volts/division, we calculate that V_{pp} , the peak-to-peak voltage of our waveform, is 6.8 divisions times 5 volts per division or 34 volts.

Now, we have the basic information we need to estimate transmitter output power: 34 volts peak-to-peak across 47 ohms.

Divide V_{pp} by 2 to get $V_p = 17$ volts. Multiply V_p by 0.707 to get the $V_{rms} = 12$ volts. Square V_{rms} to get 144 and divide by the resistance value of 47 ohms to get 3.064 watts. Since there are several sources of error involved, we estimate the power at an even 3 watts.

Assuming the scope is properly calibrated and the pattern read with accuracy, one of the major sources of error is the resistor value changing with temperature

and the effects of a long feedline between the transmitter and the load resistor. For example, if the resistance increased with heat to 50 ohms instead of the measured 47 ohms, the resulting actual power would be 2.88 watts instead of the 3 watts calculated by the formula. This difference is an error of four percent, which illustrates how important it is to use a known resistance and ensure that it does not heat up.

If these precautions are observed, this method can yield surprisingly accurate measurements in a power range where even sophisticated equipment can have problems.

“SPaddle” – A Lightweight Vertical Paddle

‘Seab’ Lyon, AA1MY

The vertical paddle or “SPaddle” was designed for the ARS “Spartan Sprint”, where station weight is a concern. This particular model weighs about 1/2 oz. and was made to fit and be taped between screw heads under an Altoids box, or to a logging clipboard. The paddle is operated with one’s hand resting on the box or the base plate, providing single-handed stability. In fact, it is designed for use outside and with gloves, where cold fingers cause errors. It is not intended to be the perfect paddle for comfy indoor use.

“SPaddle” is made from .032” thick, double sided, fiberglass printed circuit board. It could be made from more common .062 stock but would weigh more and the action will be stiffer. Notching at the “contact land” will give it a lighter touch. SPaddle can be made to meet any circumstance as dimensions are completely non-critical.

Contacts are made of #14 copper wire, soldered to the contact arms, and trimmed to fit before attaching the contact arms. File or grind a flat on the contact face. Contact spacing is adjusted by heating the solder and nudging the wire, using a thin sheet of paper as a gap set. An adjustable but weightier alternative would be to turn the contact arms parallel to the

lever, solder a nut over a hole in each arm and use a screw and locking nut. (similar to the horizontal design in QST a while back) Copper is removed from the contact land by cutting through the copper (only) with an Exacto knife, heating the strip with a hot solder tip and peeling it off. (thanks, KD1JV)

The photo shows how SPaddle is built, and the cutting layout provides nominal dimensions. A “nibbler” was used to notch the paddle arm at the “contact land” to increase flexibility. A round file would work as well. The wire and plug was happily liberated from a cheap pair of particularly painful stereo ear buds. Wires are passed through holes in the contact arms and knotted for strain relief.

That’s about it except that I’d recommend masking the contact area and spraying the SPaddle with clear varnish to preserve the shiny copper. Clear packing tape works too, but it’s more difficult to protect the whole thing. After taking time to fine tune and get the feel of SPaddle I’ve found it to be a good step toward the Spartan ideal. That, in combination with KD1JV’s remarkable “A-T Sprint” transceiver, took first place in the Skinny Division for the April ‘03 Spartan Sprint with a station weight of 12.3 oz. Feel free to make im-

provements, and please don't forget to share them with us!

73, Seab,

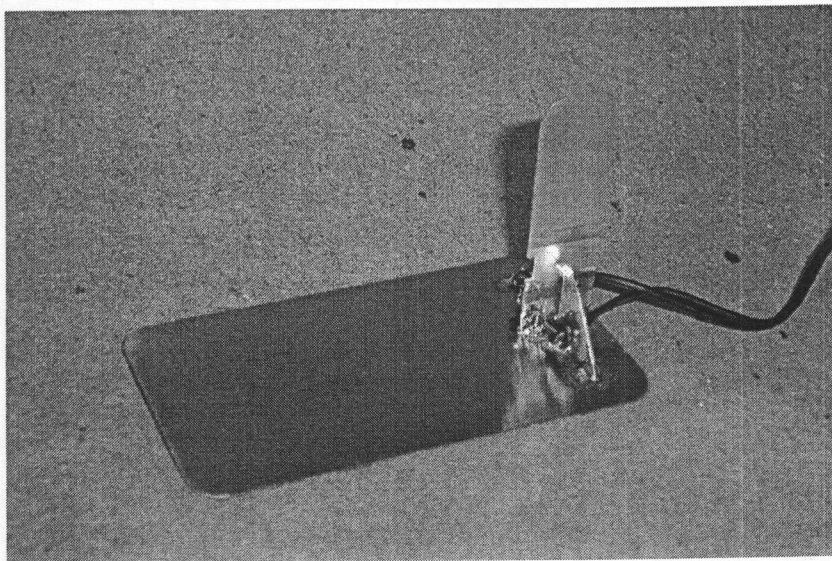
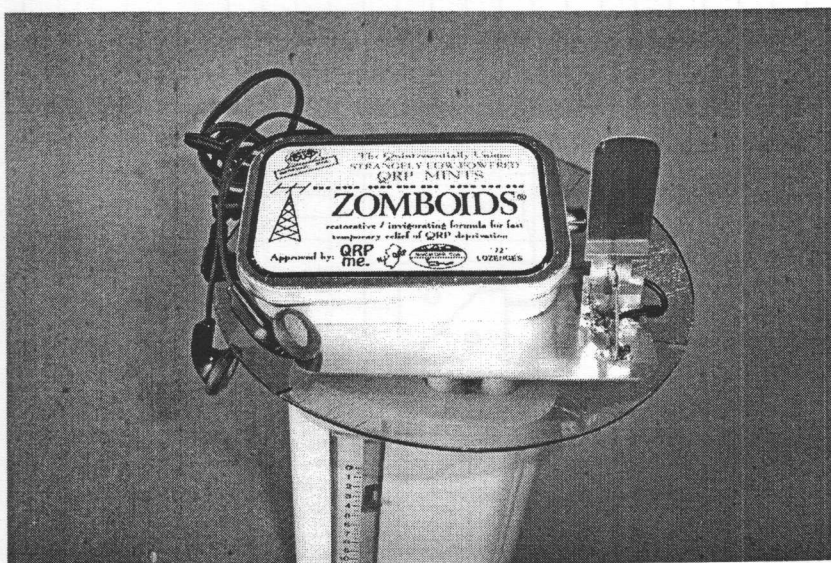

Seabury Lyon AA1MY April 10, 2003

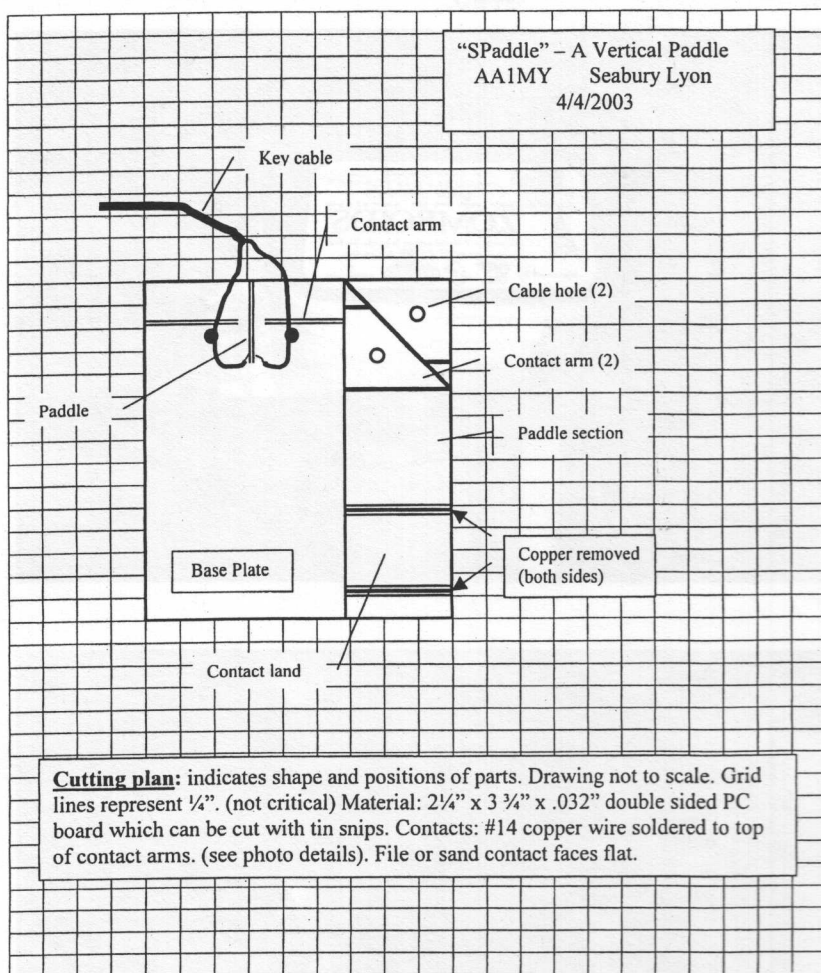

KK5PY's Te Ne Tuner

by Lew Pacely, N5ZE
lew@paceley.com

I'm immediately attracted to compact, innovative radio and accessory designs. While at Arkiecon Don, K5DW, (knowing my weakness for these things) brought me over to Dennis, KK5PY's table to see Dennis' latest wonder - the Te Ne Tuner. The Te Ne Tuner is basically a small L-network tuner (series L, shunt C) designed specifically to match end fed wires. End

fed wires are among the easiest wire antennas to erect and use and Dennis has come up with an innovative little transmatch design to throw in your pack with your rig the next time you head for the hills.

Dennis has managed to squeeze an entire tuner into a plastic 35mm film can! On the top is knob to vary the capacitance of the polyvaricon inside the film can. The

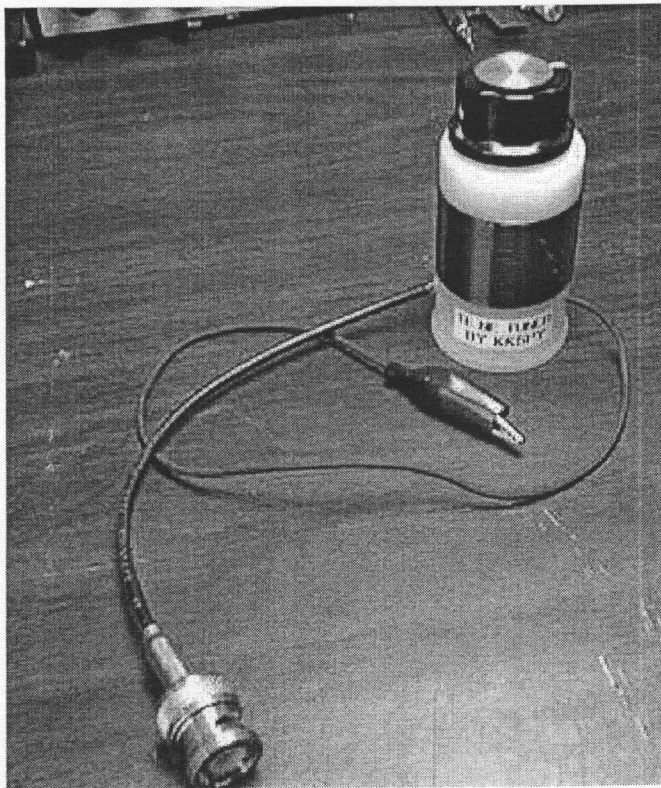

The KK5PY TENE Tuner

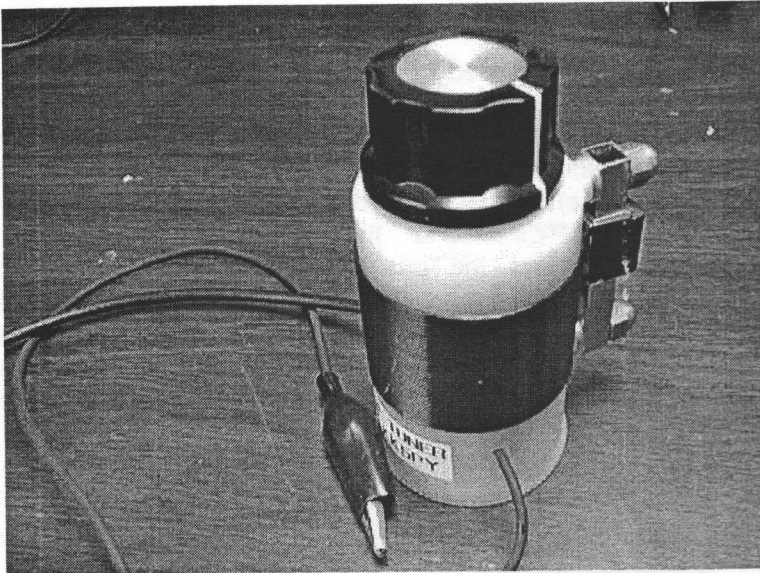

The Inductor is tuned with a sliding contact.



The TENE Tuner "innards"

inductor is wound around the film can body and tuned with a sliding contact on a brass tubing rail. A wire with an alligator clip connects to the antenna. A short piece of RG-174 coax connects the tuner to the rig. Note that the BNC connector is NOT stock. I removed the stock RCA phono male and replaced it with a BNC male.

I use an end fed inverted L with a 33' RF ground as my main shack antenna. I connected the Te Ne Tuner and was surprised to be able to use this simple transmatch to tune every band but 15m to 1.4:1 SWR or less using my MFJ-259B. On 15m I couldn't do better than 2.3:1 SWR. But that's an amazing result for such a featherweight little transmatch!

The only disadvantage I found to Dennis' design is that hand capacitance significantly affected tuning at 20m and above on my antenna. To work around the hand capacitance detuning, I simply adjusted the slider and moved my hands away to observe the result of the change. I found I could get the tuning fairly close just by listening to the background noise in my receiver.

Also, while the sliding contact is insulated by a small plastic cover, the brass tubing and hardware is not insulated. It's not very hard to accidentally get your fingers to touch the brass hardware while tuning SO USE CAUTION AND AVOID RF BURNS!!

Disclaimer: I have no business

relationship with Dennis, KK5PY, other than satisfied customer. The TENE Tuner can be ordered for \$25 + \$4 Shipping and handling from:

Dennis Foster, KK5PY
300 N. Maple
Commerce, OK 74339

Please make checks and money orders out to Dennis Foster, and it helps a bunch if you enclose a self addressed mailing label.

How to Build the NorCal Doublet Antenna

by Doug Hendricks, KI6DS-----

The NorCal Doublet Antenna came about due to my desire for a simple antenna that could be erected very fast, only needed one center support, and did not take up much storage room. Dave Gauding, NF0R, is a close friend of mine, and he had told me about a St. Louis Doublet, that used small wire for the radiators and computer cable for the feedline. I took his idea a step farther, and used computer cable for the whole antenna. Jim Duffey, KK6MC/5 and Dennis Foster, KK5PY, also contributed to the design.

Jim was the one who told me that if I made the legs 22 feet on a side that the antenna would have

basically the same radiation patterns on all bands from 40 – 10 meters. This would be very handy to have for field operation, so I decided to use it.

Here is how to make the NorCal Doublet. You will need the following materials:

- 50 feet of 4 stranded computer cable
 - 1 #0 Fishing Swivel
 - 1 Cable tie
 - 2 pieces of fishing cord
1. Take the computer cable, and strip the outer two conductors down 22 feet, leaving the two middle wires connected together.

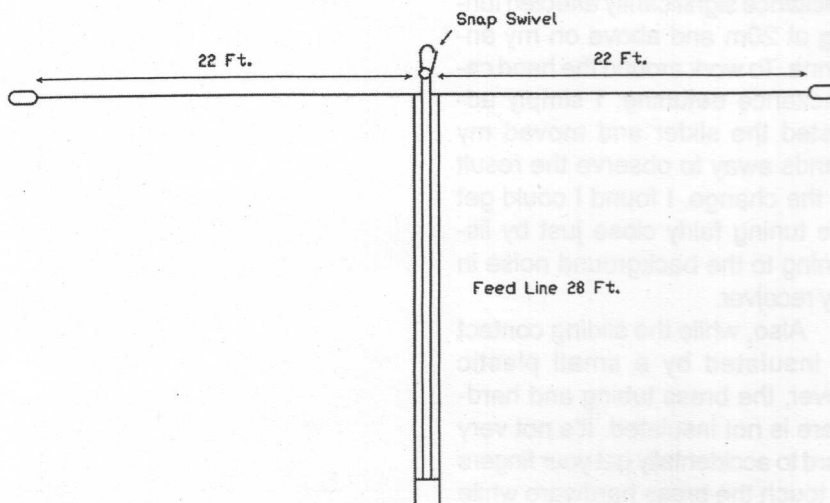

Fig. 1 Dimensions of the NorCal Doublet

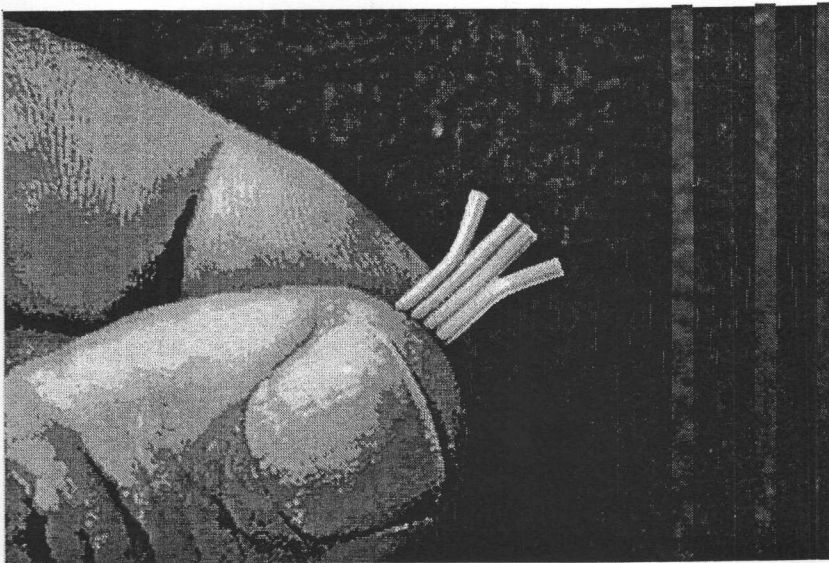

Fig. 2 Detail of starting to strip the 4 conductor computer cable.

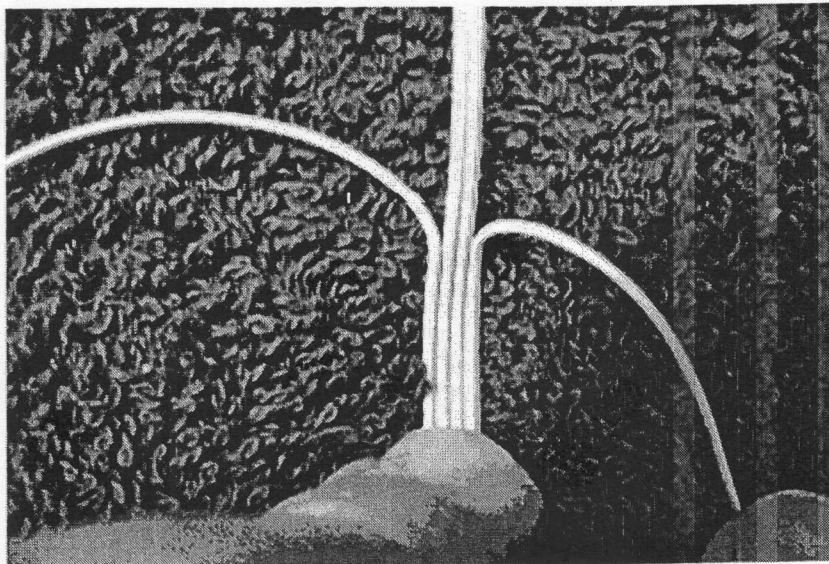

Fig. 3 Computer cable that has been stripped down 22 feet.

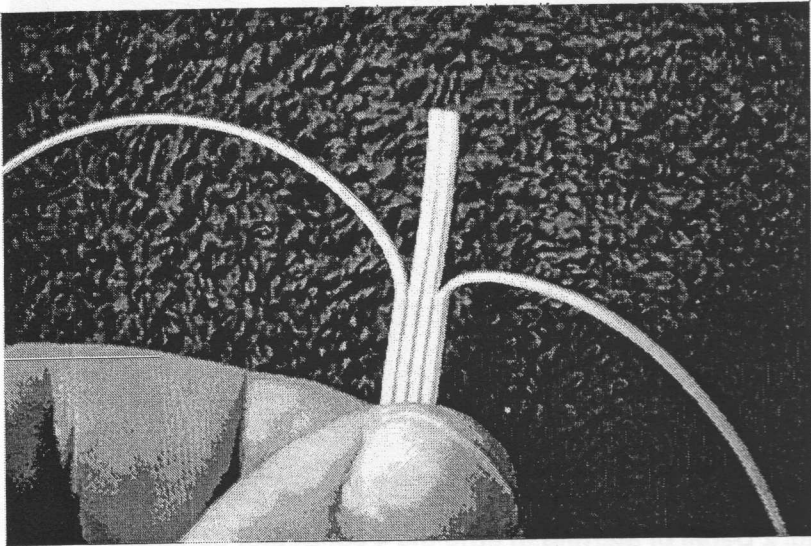

Fig. 4 Step 2. Cut the two middle wires off about 2" above the 22 foot mark where you stopped stripping the outer connectors.

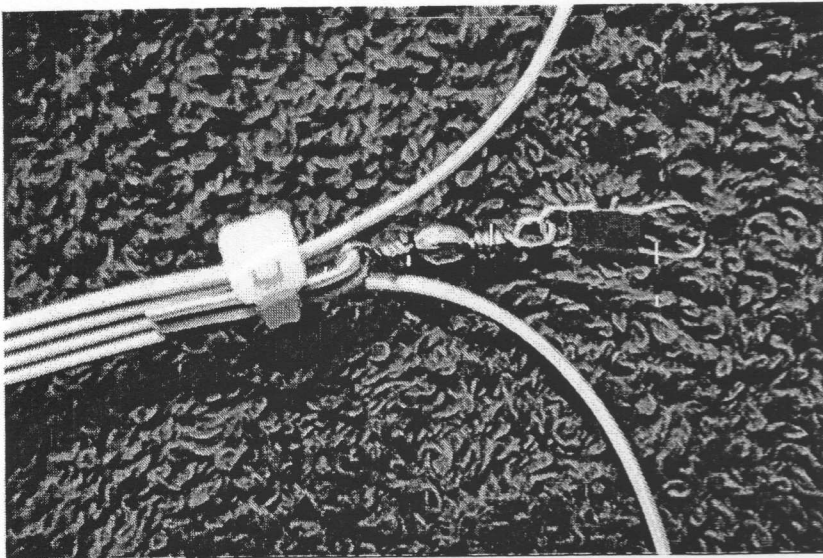

Fig. 5 Step 3. Loop the 2" piece of double strands over the eye of the fishing swivel. **Step 4.** Secure the whole thing by wrapping the tie wrap around the feedline and loop. (Dennis Foster showed me this idea)

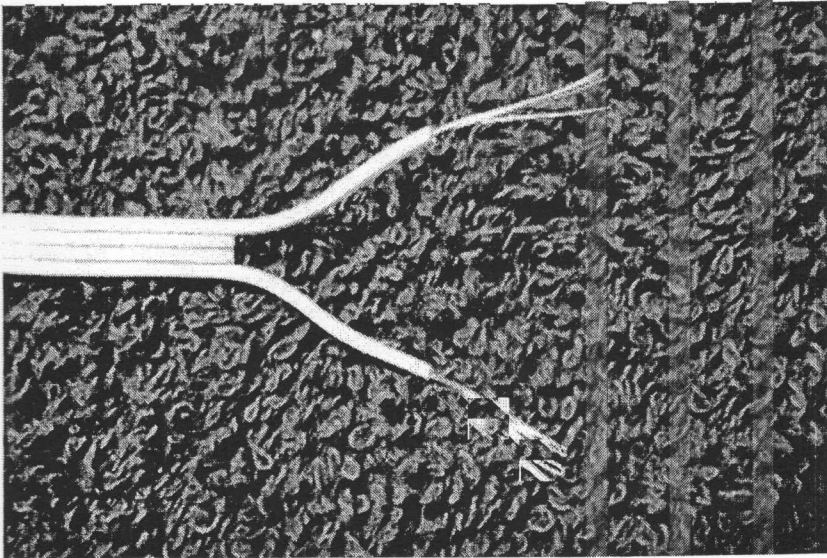

Fig. 6 Step 5. Use the remaining 28 feet of 4 conductor cable as the feedline. The outer two wires will be the feedline. Strip off about 1" of insulation on both outer connectors to hook to your NorCal BLT tuner.

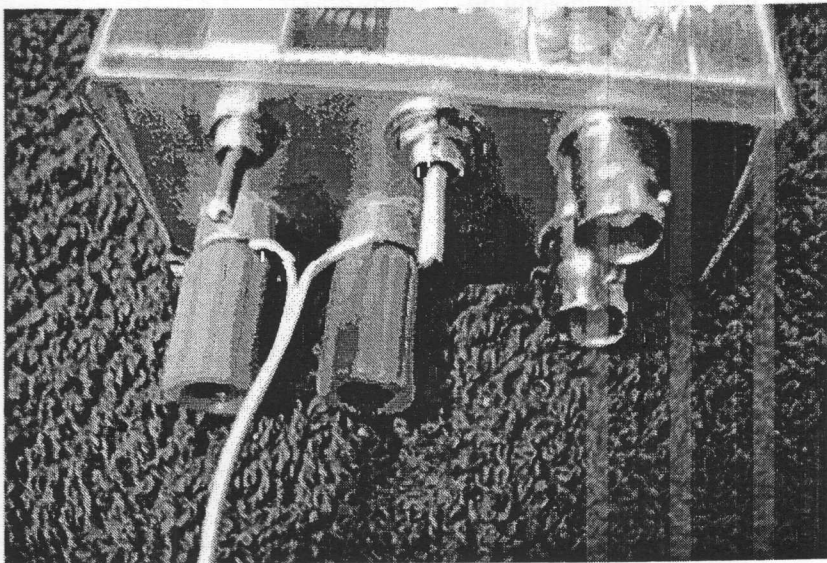

Fig. 7 NorCal Doublet Hooked to back of NorCal BLT Tuner.

Step 6. Tie a loop on each end of the two 22 foot wires.

Step 7. Tie the fishing cord to the loops.

To erect the antenna, clip the fishing swivel to the eye of the 20 foot fishing pole. Extend the pole and set it up. Stretch out the two 22 foot wires and tie off the strings to suitable supports. Connect the feedline to your tuner, and get on the air.

I have used the NorCal Doublet for years, and it is a good antenna that will let you make contacts. I have never not been able to make a contact with someone, somewhere. Is this a DX killer, no it isn't. It is a simple antenna designed to be supported by a telescoping fiberglass pole.

It is designed to be light, portable and simple to make and deploy. I have made several of them while giving a QRP talk to a forum, and everyone of them turned out just fine.

You do need to use a balanced line tuner with it though. An excellent one is the NorCal BLT, in fact, the NorCal Doublet was designed to be used with this very tuner. The BLT is available from me for \$29 including shipping. You get all of the parts needed to build the tuner, a manual, and the parts to even build a case out of precut pc board material. You can see pictures and find more information on the NorCal Web Page at:

www.norcalqrp.com

This web page is maintained by Jerry Parker, WA6OWR, who does a fantastic job for NorCal.

To order a tuner send a check or money order for \$29 US funds only to:

Doug Hendricks
862 Frank Ave.
Dos Palos, CA 93620

Please make checks or money orders out to Doug Hendricks, not Norcal.

The NorCal Web Page

NorCal maintains a web page that has many late breaking announcements of interest to QRPers. Our web master is Jerry Parker, WA6OWR. Please check the web page at:

www.norcalqrp.com

Subscription problems?

Paul Maciel, AK1P maintains the NorCal Database. If you have a question concerning your subscription please contact Paul at: ak1p@earthlink.net or by mail at:

PAUL A MACIEL
1749 HUDSON DR
SAN JOSE CA 95124

QRPP Subscriptions

QRPP is printed 4 times per year with Spring, Summer, Fall and Winter issues. The cost of subscriptions is as follows:

US and Canadian addresses: \$15 per year, issues sent first class mail. All DX subscriptions are \$20 per year, issues sent via air mail. To subscribe send your check or money order made out to Jim Cates, Not NorCal to:

Jim Cates
3241 Eastwood Rd.
Sacramento, CA 95821

US Funds only. Subscriptions will start with the first available issue and will not be taken for more than 2 years at a time. Membership in NorCal is free. The subscription fee is only for the journal QRPP. Note that all articles in QRPP are copyrighted and may not be reprinted in any form without permission of the author. Permission is granted for non-profit club publications of a non commercial nature to reprint articles as long as the author and QRPP are given proper credit. Journals that accept paid advertising, including club journals, must get prior permission from KI6DS before reprinting any article or part of an article. The articles have not been tested and no guarantee of success is implied. If you build circuits from QRPP, you should use safe practices and know that you assume all risks.

QRPP, Journal of the Nor-Cal QRP Club
862 Frank Ave.
Dos Palos, CA 93620

First Class Mail
U.S. Postage
Paid
Mailed from Zip Code
93620
Permit #72



Larry Wise KA5T
206 Sinuso Drive
Georgetown, TX 78628
Subscription will expire with Winter 02 issue.

First Class Mail