

Volume XI No. 1

Spring 2003

# QRPP



# Spring 2003

**Journal of the Northern California QRP Club**

## Table of Contents

<b>The Handiman's Guide to MOSFET "Switched Mode" Amplifiers Part 2</b>	
Paul Harden, NA5N .....	3
<b>NJ QRP Club Sniffer A Tunable Multiband Field Strength Meter</b>	
Joe Everhart, N2CX and George Heron, N2APB .....	14
<b>Build the St. Louis Quickie and Vest Pocket Vertical Antenna</b>	
Dave Gauding, NF0R .....	34
<b>NorCal Resistor Kits Return .....</b>	<b>50</b>

### From the Editor

by Doug Hendricks, KI6DS

This issue starts our 10th year of publishing QRPP and also the NorCal QRP Club. It seems like it only started yesterday, but time flies if you are having fun, and Jim and I certainly have had fun these past years. We have met so many wonderful people, and have been treated so nicely everywhere that we have gone. Both Jim and I enjoy meeting QRPers, and we like to attend as many QRP events as we can. This year our stops have included or will include Atlanticon for me, Seaside, for Jim and Arkiecon, Hamcon, Ft. Tuthill and Pacificon for both of us.

This issue has 3 outstanding articles. Paul Harden started his series in the Winter 2002 issue, and continues it here. He is a marvelous writer and teacher. The Sniffer is one of those "fun projects" that turn out to be really useful. It is a great way to learn Manhattan

construction, and a is an easy kit to build. The NJ QRP Club is selling kits, and it is a good buy at \$20. I suggest that you order one soon, before the supply runs out.

And finally, we get to reprint a great antenna construction article from our old friend, Dave Gauding, NF0R of the St. Louis QRP Club. I have built this antenna, and can report that it works great, and is a blast to setup and use. You won't believe how well it does work. Dave tests every one of his designs on the air by making 100 Qso's before he publishes them. Email him for a copy of the log, you will be impressed.

Finally, the NorCal Resistor kit is back by popular demand, but hurry there are only 200 of these available. Email Jim about availability before you order.

72, Doug, KI6DS

# MOSFET "Switched Mode" Amplifiers

## Part 2

### Gate Input & Drive Requirements

(Or, Mosfets for the Obsessive Compulsive)

by Paul Harden, NA5N

*Part 2 is for those with a desire to design and build Class D/E/F amplifiers. The following information, of a more technical nature than Part 1, may be found to be useful for understanding the gate input requirements and some driver circuits.*

#### MOSFET Capacitances

Figure 10 is a graphical representation of the capacitances in a switching MOSFET. An understanding of these capacitances is important for properly driving a class D/E/F PA. Figure 11 shows the nominal values of these parameters for the IRF510.

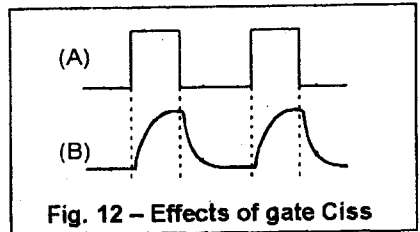
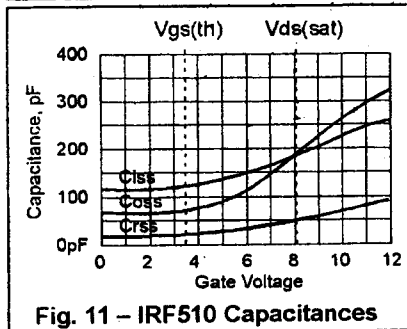
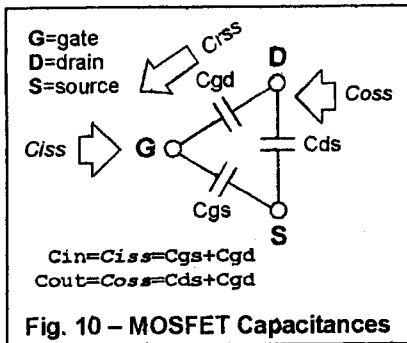

**Input Capacitance,  $C_{iss}$** , is the gate-source capacitance,  $C_{gs}$ , plus the reverse transfer capacitance,  $C_{rss}$ . For the IRF510,  $C_{iss}$  is  $\sim 120\text{pF}$  when the device is OFF, increasing to  $\sim 180\text{pF}$  when the device is ON, due to the influence of  $C_{rss}$  and the drop in drain voltage.

Applying a square wave to the gate,  $C_{iss}$  must charge before the voltage appears across the gate-source junction. This is illustrated in Figure 12, where (A) is the input square wave, and (B) is the true gate voltage, that is, the voltage impressed across the internal gate capacitance. The resulting drain current would appear virtually the same as waveform (B).

Once  $C_{iss}$  charges to  $V_{gs(th)}$ , about 4v for the IRF510, drain current begins to flow and a portion of the output capacitance,  $C_{oss}$ , is reflected back to the gate in the form of the reverse capacitance parameter,  $C_{rss}$ . This

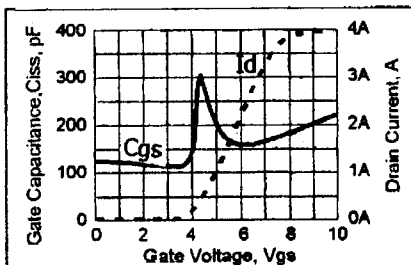

Fig. 13 – gate voltage vs.  $C_{iss}$  and Drain Current ( $I_d$ )

(and other factors) causes a sudden increase in the gate capacitance at  $V_{gs(th)}$ . This is illustrated in Figure 13, with  $V_{gs(th)}$  at 4.0v. The graph is derived from the data sheets, application notes, and measurements I have made on the IRF510.

This rather complex input capacitance graph is not shown in Fig. 11, as most data sheets show only the *average* capacitance over the gate or drain voltage range, not the aberration that occurs when drain current first begins to flow. This is important to realize, as it alters the actual gate voltage waveform one will observe on an oscilloscope when driving with a square wave.

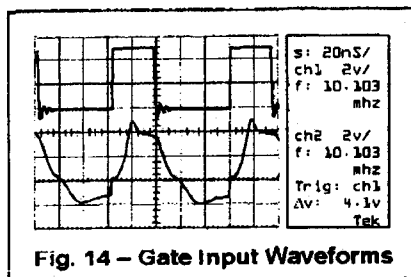

Fig. 14 – Gate Input Waveforms

Figure 14 is an oscilloscope display showing the waveforms one can expect. The gate waveform serves as a great diagnostic tool in evaluating your class D/E/F transmitter.

I drive the mosfet with a low-Z emitter follower. The top trace (Ch.1) shows the input to the emitter follower, a fairly

pure square wave at 10.103 MHz on a 30M transmitter. The bottom trace (Ch.2) is the gate waveform. The gate is biased at 3vdc, such that the TTL square wave drives the gate from about 3v, below  $V_{gs(th)}$ , to a little more than 8v for saturation. When the square wave goes from LO to HI, the gate voltage immediately rises to 4.2v, where it hesitates – a visual indication of the actual gate threshold voltage,  $V_{gs(th)}$  for this device. This is the point where drain current begins to flow. The slower slope between  $V_{gs(th)}$  and 8v is due to the increased  $C_{iss}$  above  $V_{gs(th)}$  on Fig. 11. This is also the area of maximum gain of the device. The desired flattening out of the gate drive at 8v indicates the mosfet is in saturation, although this is confirmed by monitoring the drain voltage, as discussed later.

When the gate drive goes from HI to LO, gate voltage returns to the 3v bias level rather sluggishly, due to  $C_{iss}$  discharging. Note that at  $V_{gs(th)}$ , the falling waveform again changes its slope – due to  $C_{iss}$  being altered by the gate junction storage charge effect when gate voltage falls below  $V_{gs(th)}$ .

### Gate Driver Considerations

Of importance in class D/E/F is the time to reach  $V_{gs(th)}$ , the gate threshold voltage, after application of the gate drive going HI. This is described by:

$$t = \frac{C_{iss} \times V_{gs(th)}}{I_g}$$

Solving for gate current,  $I_g$ :

$$I_g = \frac{C_{iss} \times V_{gs(th)}}{t}$$

The above equation indicates that the higher the gate current, provided by the driver stage, the faster  $C_{iss}$  will charge, and the higher the efficiency of the PA.

For class D/E/F, the point of the square wave drive is to get through the linear region as soon as possible. This

means  $C_{iss}$  should be charged as quickly as possible.

I recommend striving for 15–20nS. See Figure 15. This is also consistent with the ~16nS rise time,  $t_r$ , of the IRF510. "Tr" is theoretically the fastest  $C_{iss}$  can be charged.

The figure shows the input gate drive (A) being a 25% duty cycle, or 90° of the RF cycle. At 10.1 MHz, the gate drive "pulse" would be about 25nS, and to charge  $C_{iss}$  two times faster would indicate 12nS, as shown in

(B). From the previous equation, this would indicate a gate current of 50mA is required. This is a bit high for QRP!

I have found a driving current of 25–30mA to be a nice compromise to charge  $C_{iss}$  sufficiently fast for high efficiency. Referring to Fig. 15 (B), if the gate waveform does not flatten out at the 8v level (looks more like a sine wave), the driver is not providing sufficient current to the gate. Driving the gate voltage to saturation quickly, by providing sufficient gate drive current, is paramount in achieving the

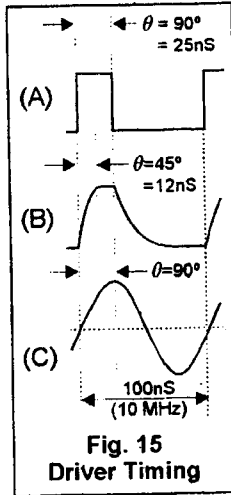

Fig. 15

Driver Timing

high efficiency of class D/E/F. The 25mA of drive current will save 200mA or more of PA current at 5W QRP. Observing the oscilloscope drive waveform in Fig. 14, note that  $C_{iss}$  charges in 18–20nS at 10.1 MHz. This 30M transmitter has an overall efficiency of 82%, which includes the 40mA of key-down current due to the TX mixer, comparator and emitter follower driver providing the gate current. This same 18–20nS  $C_{iss}$  charge time will cause a lower efficiency on 20M, as it's approaching

the period of the RF. At 40/80M, this 18–20nS rise time will produce higher efficiencies, since it is a smaller percentage of the RF cycle at lower frequencies..

Also note that the input gate square wave in Fig. 14 is about a 30% duty cycle – 30% ON and 70% OFF. The output power from the class D/E/F PA is determined by the duty cycle. With the IRF510, a 15% duty cycle produces about 1W output; about 5W at 30%, and 8W at 45%. Efficiency begins to drop above 45% duty cycle.

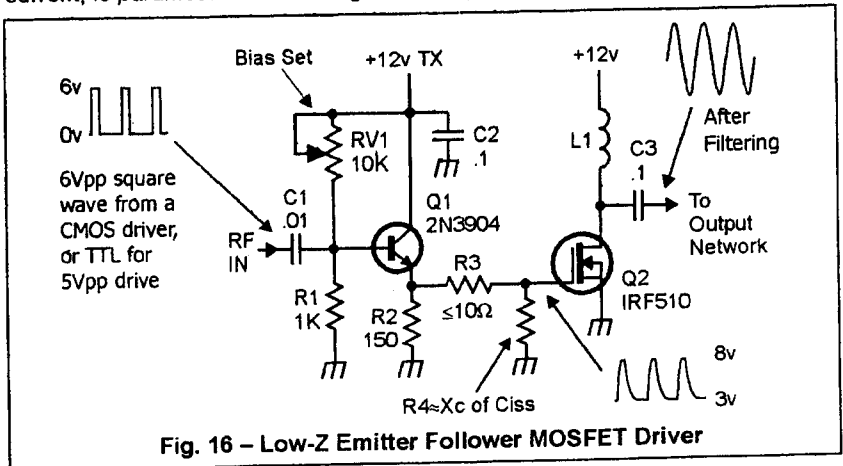

Fig. 16 – Low-Z Emitter Follower MOSFET Driver

## 25mA Emitter Follower Driver

The square wave drive can be developed by some type of CMOS or TTL gate. These alone do not have the current sinking capabilities needed to properly drive the IRF510. Some type of current booster, plus the ability to shift the dc level of the input square wave is required. The emitter follower circuit in **Figure 16** is one approach. This works best if you provide a 6V square wave to Q1, such as from a 6-8v CMOS gate, rather than 5V TTL. This is due to the 0.7v drop in the emitter follower, leaving only about 4V from a TTL drive. This may not drive the IRF510 into saturation.

The input square wave is dc shifted by C1 (dc blocking) and the RV1-R1 bias network. Adjust RV1, by monitoring the gate on an oscilloscope, as follows: when the input square wave is LO, the voltage on Q2 gate should be about 3v; when the input goes to +6v HI, the gate voltage should be between 8-9v, depending upon the loading to the circuit. This 3-8v output is developed across R2 and R4. The 3v level is to ensure the IRF510 is OFF, <Vgs(th), and 8v for saturated ON.

Q1 is powered from the +12v TX term to shut down the driver in receive, in the event RV1 is misadjusted to cause mosfet drain current to flow when the mosfet should be OFF.

R3 is 3.9-10Ω to de-Q the gate and prevent VHF oscillations. The value is not critical. R4 is a resistive load to both the Q1 emitter follower and Q2 gate. The value should be about the Xc of the mosfet Ciss, ~120-180pF, or a few hundred ohms, depending upon the transmit frequency. Initially, you can make R4 a trim pot and adjust for the best possible square wave (**Fig. 14**) to match to the Ciss of the IRF510. This value will vary from device-to-device.

If the rise time is slower than 25-30nS,

then more gate current is needed by decreasing the value of R2. In this example, if a 3v-to-8v signal is formed across R2, then the output drive current would be about 33mA on the drive peaks. ( $I=5V/150\Omega$ ). Ohms law is thus used to determine R2 for the drive current desired.

In the technical literature, the following equation is used to calculate the driver resistance, Rd, needed (R2 in **Fig. 16**):

$$R_d = \frac{-t}{C_{iss} \ln(1-V_2/V_1)}$$

Where, t is the desired rise time of the gate signal (usually 15-20nS), V1 is Vg at saturation, V2 is the peak-to-peak gate voltage, or V1 minus Vgs(on), and Ln is the natural logarithm. For the driver in **Fig. 16**:

$$\begin{aligned} R_d &= \frac{-t}{C_{iss} \ln(1-5v/4v)} \\ &= \frac{-20nS}{120pF(-1.38)} = 120\Omega \end{aligned}$$

Keep in mind, this value of Rd is based on the ideal current to charge Ciss, about 50mA. Again, I have found 25-30mA to be sufficient. This exercise does show that using Ohms Law for R2 is close enough (and a lot easier!).

## The NA5N Mosfet Driver

Another driver scheme developed for my class D/E transmitters is shown in **Figure 17**. It is similar in some regards to the emitter follower driver in **Fig. 16**.

The low-level RF output from the TX mixer is applied to a high speed comparator, which converts the RF sinewave into a square wave. The operation of the TX mixer and comparator is beyond the scope of this part of the article, but will be presented in a class D & E transmitter construction project in Part 3. Suffice it to say that the duty cycle of the square wave is variable from about 15-45%. The

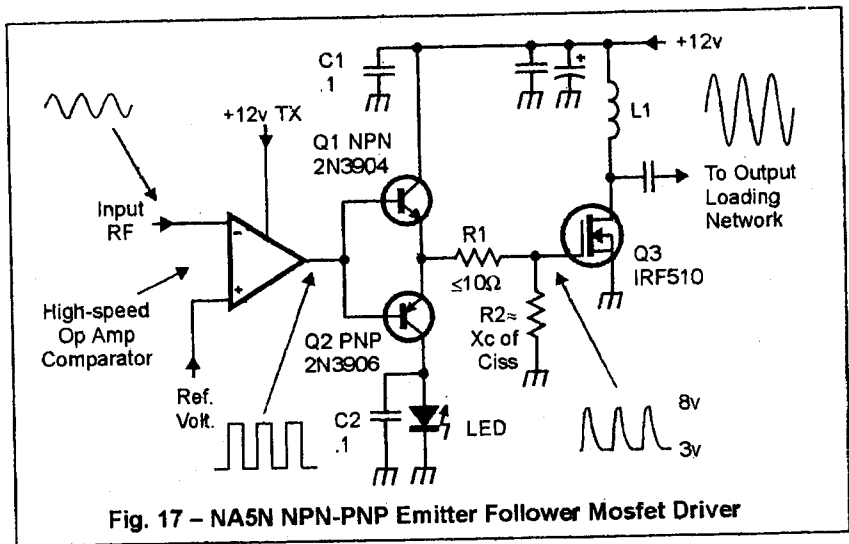

Fig. 17 - NA5N NPN-PNP Emitter Follower Mosfet Driver

comparator is powered from +12v TX, so that during receive, the output is 0v, disabling the IRF510 drive circuitry.

On transmit, the comparator output is an 8Vpp square wave at the RF frequency, such that the dc output levels are about +1v LO to +9v HI.

This emitter follower is an NPN-PNP pair, commonly called a "totem pole" configuration. Since the base voltage is an 8v square wave, the transistors are driven nearly into saturation and cutoff, acting as switches. When the comparator output goes from LO to +9v HI, both the NPN and PNP are turned on. Q1 emitter voltage is the +9v base voltage, minus the 0.7v junction drop. This 8.3 volts is applied to the emitter of Q2, allowing it to be forward biased as well. The 8.3v is also the PA gate drive.  $R1+R2||Xc$  is the output load to Q1 and the input impedance to the IRF510, such that the impedance is self matching. This yields 25-30mA of gate current drive from Q1. About 8mA passes through Q2, illuminating the LED.

When the square wave goes to +1v LO, Q1 and Q2 are barely forward

biased and conducts ~8mA due to the LED. This causes a 2v drop across the LED, and ~1v across Q2, leaving +3v at the Q1-Q2 emitters - and the mosfet gate - turning off the IRF510.

Even though there is only 2.5v drive to the IRF510 gate, the +8v previously on the gate  $C_{iss}$  is now discharging. This decaying gate voltage also appears on the Q1-Q2 emitters. The low Q2 emitter-collector resistance, which is in parallel to R2, gives  $C_{iss}$  a lower resistance to discharge into. When  $C_{iss}$  is discharged, Q2 turns off. Thus, the purpose of Q2 is to place a low-Z load across the IRF510 gate to quickly discharge  $C_{iss}$  when the mosfet turns off.

For class D/E/F efficiency, the drain

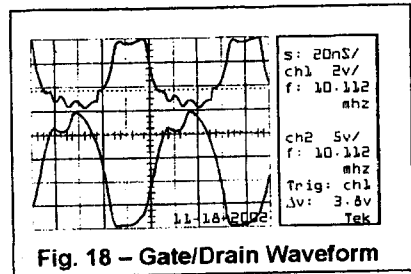

Fig. 18 - Gate/Drain Waveform

current must be zero before the next square wave LO to HI transition occurs.

**Figure 18** is an oscilloscope display of this circuit driving a class E transmitter. The top trace is the **gate voltage** at 2v/div.  $V_{gs(th)}$  of this particular device is 3.8v, shown by the dotted line marker on the oscilloscope. Gate voltage rises fairly quickly to saturate at 8v. When the drive signal switches from HI to LO, the action of Q2 discharges  $C_{iss}$  and drops the gate voltage below  $V_{gs(th)}$  faster than the emitter follower version in **Fig. 16**. In this case,  $R1=3.9\Omega$  and  $R2=220\Omega$ .

Gate voltage settles out around 2.5v, due to the LED and Q2, keeping the IRF510 turned off. If the gate were allowed to discharge to 0v, it would take longer to charge  $C_{iss}$  when the next gate drive goes HI. This saves 2.5v of  $C_{iss}$  charging. The main purpose of the LED is to provide this gate bias when the mosfet is off. Of course it does make for a nice XMIT indicator as well, indicating RF is being supplied to the IRF510, rather than simply coming off the key line.

The bottom trace is the **drain voltage** (Vd) at 5v/div. The peak-to-peak voltage is about 25v, the  $2V_{cc}$  (or  $2V_{dd}$ ) expected. Note that when the gate voltage reaches +3.8v  $V_{gs(th)}$  going HI, the drain voltage is just passing through 12v  $V_{cc}$  – the point when drain current is zero. This is exactly the point you want the gate voltage to reach  $V_{gs(th)}$  to start drain current to flow. Vd drops from 12v down to 0v, indicating drain current is increasing. When the gate voltage reaches 8v, drain current should be saturated, evidenced by Vd reaching -0v. In this case,  $V_d=0.4v$ , certainly indicating the IRF510 is in saturation, or the "full-ohmic on" region. This is important, as the closer to 0v at maximum drain current, the smaller the power losses across the drain-source

junction. The lower the loss, the higher the efficiency. The drain current is also building up the current field in inductor L1 at this time. If drain voltage does not reach <1v, the mosfet is not in saturation.

When the gate voltage begins it's HI to LO transition, to turn OFF the mosfet,

### Calculating PA Efficiency

PA efficiency of class D/E/F can be easily measured on an oscilloscope by measuring the LO to HI gate drive transition to the point the drain current first saturates (when drain voltage hits the lowest value). This accepted method is basically a measure of how long you spend in the linear region. The time to reach saturation is compared to the time of the RF cycle to determine the phase delay, in degrees. The steps to calculate PA efficiency, based on the NA5N driver and PA waveform in **Fig. 18**, are shown below. Calculating efficiency based on measuring PA currents (input vs. output power) yielded 91%.

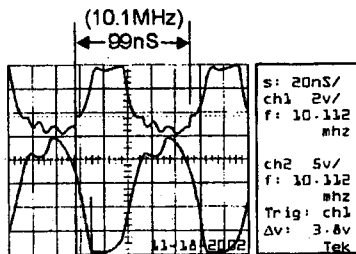

$$\theta = 11\text{ns} = 40^\circ$$

- ① Measure time difference (in ns)
- ② Convert to phase difference (degrees)

$$\theta = \frac{11\text{ns}}{99\text{ns}} = .11 \times 360^\circ = 40^\circ$$

- ③ Calculate PA efficiency,  $\eta$

$$\eta = \frac{\sin\theta \times 360^\circ}{2\pi\theta} \quad \text{where } \sin 40^\circ = .64$$

$$\eta = \frac{.64 \times 360^\circ}{6.28 \times 40^\circ} = \frac{230}{251} = 92\%$$



drain voltage begins to rise, indicating drain current is turning off as desired. Gate voltage drops from +8v to +3.8v  $V_{gs(th)}$  faster than the single emitter follower waveform in Fig. 16, due to the loading effect of Q2. Drain voltage rises above 12v  $V_{DD}$  as the current stored in L1 now dumps into the output network when drain current stops.

In class E, L1 is also part of the output tuned circuit, resonant at the transmit frequency by the shunt capacitor in conjunction with the internal  $C_{oss}$ . See "Cv" in Fig. 6, Part 1. When the current stored in L1 is depleted, drain voltage will begin to decrease. However, in class E, the energy stored in the capacitor parallel to L1 will provide voltage when the current in L1 is depleted, causing the familiar "fly-wheel" effect of the resonant circuit. In Fig. 18, the hesitation in drain voltage at 20v is when L1 runs out of current, and the voltage peak to 25v is the voltage being supplied by the shunt capacitor, which has been charged to 2V<sub>DD</sub>. Two or three peaks may be seen at the 25v level, depending upon the harmonic power present. With this waveform, the transmitter had a power range of 1W to 9W (by varying the duty cycle from 15% to 45%) with an overall efficiency of 85% and a PA efficiency of 92%.

### Class D Drain Output Efficiency

The output capacitance,  $C_{oss}$ , lowers efficiency, since it must be charged to ~2V<sub>DD</sub> by the mosfet. The equations below show how efficiency,  $\eta$ , is based on the switching power,  $P_s$ , lost across  $C_{oss}$ . The following math only serves to make two important points below.

At  $V_{DD}=12v$ , for a 20M 5W transmitter, with  $C_s=120pF$  and  $V_{sat}=0.5v$  (where  $P_s$  is the switching loss in watts):

$$V_{eff} = V_{DD} - V_{sat} = 12v - 0.5v = 11.5v$$

$$P_s = C_{oss}(2V_{eff})^2 \times 2f_o =$$

$$= 120pF(2 \times 11.5)^2 \times 2(14MHz) = 1.78W$$

$$\eta = \frac{P_o}{P_o + P_s} = \frac{5W}{5W + 1.78W} = 74\%$$

In some of the amateur literature, the recommendation is sometimes given to raise the mosfet drain voltage for higher efficiency. Let's see if this is true.

At  $V_{DD}=18v$ , to produce 5W output power:

$$V_{eff} = 18v - 0.5v = 17.5v$$

$$P_s = 120pF(2 \times 17.5)^2 \times 2(14MHz) = 4.1W$$

$$\eta = \frac{5W}{5W + 4.1W} = 55\%$$

Increasing  $V_{DD}$  to 18v does produce 5W with less drain current. However, charging  $C_{oss}$  to 36v (2V<sub>DD</sub>) greatly increases the switching power loss, lowering efficiency from 74 to 55%. This should dispell the rumor that increased  $V_{DD}$  lowers efficiency – and that the +12v customarily used by homebrewers is actually quite ideal for switching mosfet QRP PAs.

The second point with the above equations is how the *switching losses are frequency dependent*, due to the term "2fo." The lower the frequency, the lower the losses, and hence higher efficiency. Therefore, a Class D/E/F PA will be much more efficient on 80M than 20M. This is why most Class E circuits on the internet are only for 160M or 80M, as even a sloppy job of designing the circuit and using a sinewave drive will still yield high efficiency. Re-calculating the 20M 12v QRP example to 160M yields an astounding 96%.

$$V_{eff} = 12v - 0.5v = 11.5v$$

$$P_s = 120pF(2 \times 11.5)^2 \times 2(1.8MHz) = .23W$$

$$\eta = \frac{5W}{5W + .23W} = 96\% !!!$$

This is also why those scaling these amplifiers for 20M have had disappointing results, as the switching power losses double as you double the operating frequency.

## A few loose ends ...

### IRF510 vs. IRL520

The IRL520 is a logic family mosfet, meaning it is designed to saturate with only 5V (TTL logic HI) on the gate. It would therefore seem the IRL520 would be ideal for a class D/E/F PA for QRP, since it can be turned on with only a 2v swing on the gate. However, the input capacitance,  $C_{iss}$ , for the logic drive devices is very high – in the order of 300-400pF. This is tolerable for their intended purposes in 50-100 KHz switching power supplies, but virtually impossible to drive at HF frequencies. I have built some fairly successful Class C PAs with IRL520's, but efficiencies at Class D/E/F never much more than 50%. Theoretically, one can drive the gate with a parallel inductance to cancel out this huge capacitance through resonance, but I have not yet tried this. There are some SMC SOT-23 logic mosfets with a lower  $C_{iss}$  worth experimenting with.

### Other switching MOSFETs

Just look through the Mouser or Digi-Key catalog and you will see listings for legions of cheap, switching mosfets. Many can be used in lieu of the IRF510. In order to use them for Class D/E/F, you need to know primarily the  $V_{gs(th)}$ ,  $V_{gs(sat)}$ , and output capacitance,  $C_{oss}$  or  $C_{ds}$ . Maximum drain current is also important. For QRP power levels, you want a device with a  $I_d(max)$  of 1-2A for smooth power control with a 50% duty cycle, since you are forcing maximum  $I_d$  for some period of time. The IRF510  $I_d(max)$  is about 4A. Such a high  $I_d(max)$  actually makes the IRF510 a bit difficult to control in the 5W or less range.

### Surface Mount MOSFET's

Some of the switching mosfets that meet the above requirements are only available in surface mount packages, such as SOT-23's with  $I_d(max)$  around

1.5–2A. I have built a class D and E PA with these devices with good success, and surprisingly, the high efficiency causes little heating of these very small packages. However, operating them Class C causes excessive heating above about 2W. There is just very little room for error with a SOT-23 due to the low power dissipation of such small physical packages.

### Other available literature

There is plenty of available information on Class D/E/F transmitters on various websites, engineering magazine articles and the application notes in National and Motorola data books. However, this information needs to be used with caution for QRP, as most are based on RF type switching mosfets, deal with power ranges in the hundreds of watts, push-pull circuits, or frequencies below HF, such as for AM broadcasting or ultrasonic use. Still, these articles are worth further study for those wishing to learn more, keeping the application of the article in mind.

### Interpreting the IRF510 Data Sheet

The data sheet for the International-Rectifier IRF510 is in **Appendix B**. This is extracted from their complete data sheet.

**Maximum Ratings.** Continuous drain current is important, as this is about the drain current for the period of time the IRF510 is in saturation. This should stress why controlling output power with a small duty cycle is important. Maximum gate-to-source voltage is  $\pm 20v$ , which will easily handle the +10v required for saturation.

**Electrical Characteristics.**  $R_{DS(on)}$  is the "on-resistance," which only occurs when fully saturated. Note the Test Conditions define the saturated state with  $V_{GS}=10v$ . When in the linear region,  $R_{DS}$  is the standard equation for  $R_L = V_{dd}^2 / 2P_o$ .

**Vgs(th)** is the gate voltage where drain current begins to flow. Note the huge range - typical of mosfets. Most devices will be about 3.5-4v. **LD** is the internal inductance that adds to the external inductance on the drain. In class E, where the drain inductance forms a tuned circuit, the value of LD is sufficiently low to not alter calculations. **Ciss** and **Coss** are the input and output capacitances. These are very important, especially for class D/E/F. Note the test conditions are for  $V_{gs}=0v$ , that is, with no drain current flowing. With drain current,  $V_{ds}$  will drop from +12v to 0v (at saturation) and these values change, as shown in Fig. 3 on the data sheet. Timing parameters, **Td(on)**, **Tr** and **Td(off)** are defined in Fig. 6. For class D/E/F, the faster the better. Theoretically, the fastest a mosfet can switch is the time of  $Tr+Tf+Td(on)+Td(off)$ , which equals 54nS for the IRF510. Tf is assumed to be about Tr if not listed. The maximum frequency would thus be  $1/54nS = 18.5MHz$ . Tr and Tf define the typical time to charge and discharge Ciss and Coss. These times can be increased a bit by increasing the gate drive current, as discussed in the article, and raising fmax to some extent.

Fig. 1 shows drain current ( $I_d$ ) vs the drain-source voltage ( $V_{ds}$ ) at 25°C. This is similar to the transfer characteristic curves for a BJT. Fig. 2 is the same, except at a device temperature of 175°C. Note that as the IRF510 gets hotter, drain current gets less, protecting itself from thermal runaway. This is opposite the effect of a BJT, where the BJT gets hotter, more collector current flows, producing more heat, then more current, until the device destroys itself by thermal runaway. Again, a mosfet protects itself from

thermal runaway. This explains why your class C IRF510 PA drops in output power as the device gets hot.

Fig. 4 is the transfer characteristics of the IRF510. This shows how much drain current flows vs. the gate voltage. Note that the graph begins at 4v, as less than that, the mosfet is in "cut off." Also note the drain current is less at 175°C. This shows how device saturation occurs around  $V_{gs}=8v$ , where little further increase in drain current occurs with increasing  $V_{gs}$ . Below  $V_{gs}=8v$  is the linear region, although it is not very linear (more "curved" in shape). The transfer curve is steepest between about 4 to 5v  $V_{gs}$ . This is the area of maximum gain. This shows why IRF510s have also been used as very high gain RF amplifiers or mixers, by exploiting a gate voltage only slightly above  $V_{gs(th)}$ .

Fig. 5 shows the maximum drain current vs. temperature. For class C QRP transmitters, device temperature can quickly rise to 150°C on key down, but still in the safe operating region for 1A of drain current. Class D/E/F runs considerably cooler. In fact, a barely warm IRF510 after 30 seconds of keydown is the ultimate proof of the increased efficiency. Try that with class C and you'll lose your fingerprint!

In Part 3 of this series will be two construction projects for you to build - a QRP Class D and E transmitter using the IRF510. Both can be added to about any QRP transmitter to produce 5W output, or for a "roll-your-own" transmitter.

72, Paul Harden, NA5N  
 na5n@zianet.com  
 pharden@nrao.edu

## Appendix B – IRF510 Data Sheet

**International**  
**IR Rectifier**

HEXFET® Power MOSFET

**IRF510**

- Dynamic  $dv/dt$  Rating
- Repetitive Avalanche Rated
- 175°C Operating Temperature
- Fast Switching
- Ease of Paralleling
- Simple Drive Requirements

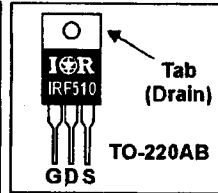
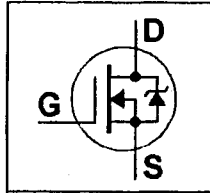

### Description

Third generation HEXFETs from International Rectifier provide the designer with the best combination of fast switching, ruggedized device design, low on-resistance and cost-effectiveness.

The TO-220 package is universally preferred for all commercial-industrial applications at power dissipation levels to approximately 50 watts. The low thermal resistance and low package cost of the TO-220 contribute to its wide acceptance throughout the industry.

### Absolute Maximum Ratings

	Parameter	Maximum	Units
$I_D$ @ $T_c = 25^\circ\text{C}$	Continuous Drain Current, $V_{GS} @ 10\text{V}$	5.6	A
$I_D$ @ $T_c = 100^\circ\text{C}$	Continuous Drain Current, $V_{GS} @ 10\text{V}$	4.0	A
$I_{DM}$	Pulsed Drain Current	20	A
$P_D$ @ $T_c = 25^\circ\text{C}$	Power Dissipation	43	W
$V_{GS}$	Gate-to-Source Voltage	$\pm 20$	V
$T_J$ $T_{STG}$	Operating Junction and Storage Temperature Range	-55 to +175	$^\circ\text{C}$

### Electrical Characteristics @ $T_J = 25^\circ\text{C}$

	Parameter	Min.	Typ.	Max.		Test Conditions
$V_{(BR)DSS}$	Drain-to-Source Breakdown Voltage	100	—	—	V	$V_{GS}=0\text{V}$
$R_{DS(on)}$	Drain-to-Source On-Resistance	—	—	0.54	$\Omega$	$v_{GS}=10\text{V}, I_D=3\text{A}$
$V_{GS(th)}$	Gate Threshold Voltage	2.0	—	4.0	V	$V_{DS}=V_{GS}$
$g_{fs}$	Forward Transconductance	1.3	—	—	S	$V_{DS}=50\text{V}, I_D=3\text{A}$
$I_{DSS}$	Drain-to-Source Leakage Current	—	—	25	$\mu\text{A}$	$V_{GS}=0\text{V} @ 25^\circ\text{C}$
$I_{GSS}(fwd)$	Gate-to-Source Forward Leakage	—	—	100	nA	$V_{GS}=20\text{V}$
$I_{GSS}(rev)$	Gate-to-Source Reverse Leakage	—	—	-100	nA	$V_{GS}=-20\text{V}$

### Electrical Characteristics @ $T_J = 25^\circ\text{C}$ - Cont'd

	Parameter	Min.	Typ.	Max.		Test Conditions
LD	Internal Drain Inductance	—	4.5	—	nH	Lead to die
LS	Internal Source Inductance	—	7.5	—	nH	Lead to die
Ciss	Input Capacitance	—	180	—	pF	$V_{GS}=0\text{v}$ , $f=1\text{MHz}$
Coss	Output Capacitance	—	81	—	pF	$V_{GS}=0\text{v}$ , $f=1\text{MHz}$
Crss	Reverse Transfer Capacitance	—	15	—	pF	$V_{GS}=0\text{v}$ , $f=1\text{MHz}$
Td(on)	Turn-on Delay Time	—	6.9	—	nS	$V_{DD}=50\text{v}$ , $I_D=5.6\text{A}$
Tr	Rise Time	—	16	—	nS	$V_{DD}=50\text{v}$ , $I_D=5.6\text{A}$
Td(off)	Turn-off Delay Time	—	15	—	nS	$V_{DD}=50\text{v}$ , $I_D=5.6\text{A}$

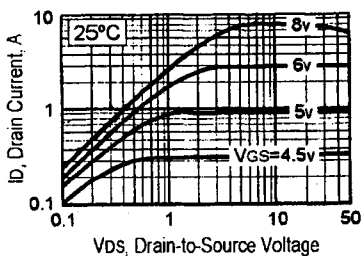

Fig. 1. Typical Output Characteristics ( $25^\circ\text{C}$ )

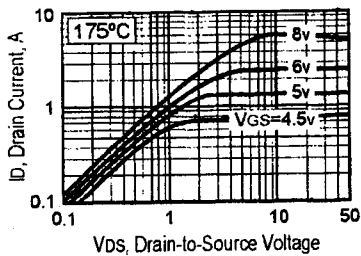

Fig. 2. Typical Output Characteristics ( $175^\circ\text{C}$ )

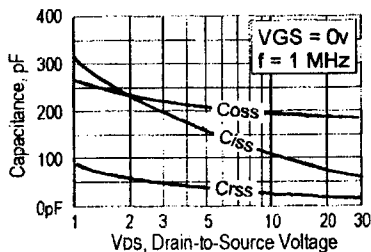

Fig. 3. Typical Capacitance vs. VDS

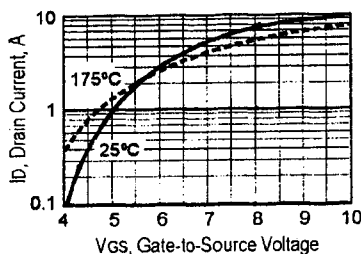

Fig. 4. Typical Transfer Characteristics

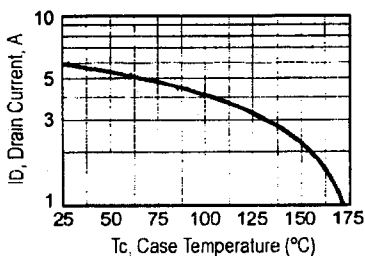

Fig. 5. Maximum Drain Current vs. Case Temperature

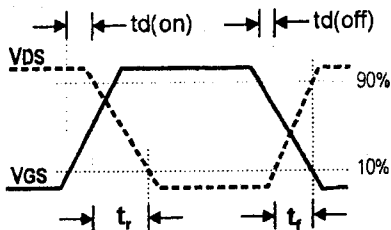
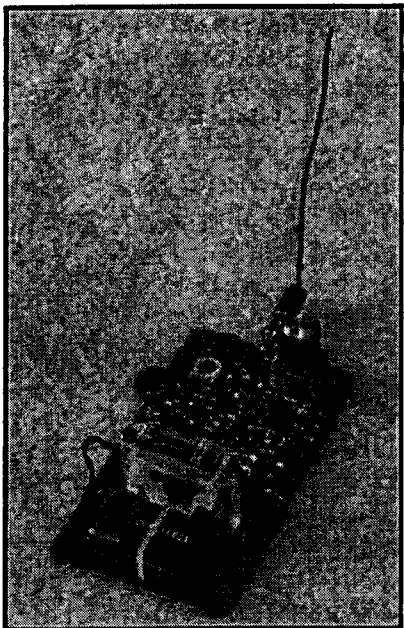

Fig. 6. Switching Time Waveforms

# NJ QRP Club Sniffer

## A Tunable Multiband Field Strength Meter

Joe Everhart, N2CX [n2cx@voicenet.com](mailto:n2cx@voicenet.com)  
and George Heron, N2APB [n2apb@amsat.org](mailto:n2apb@amsat.org)



### INTRODUCTION

An RF field strength meter is one of the simpler – yet more valuable – pieces of test equipment a ham can have around the shack. By nature, our interest centers on the characteristics of the radio frequency energy we are pumping out of our antenna ... how much, how efficient, its directivity and bandwidth. A properly used Field Strength Meter (FSM) can provide invaluable relative insight to each of these characteristics, and more.

The **NJQRP Sniffer** is a

tuned-input, multiband-capable FSM for the HF amateur bands that is easily constructed using commonly available components. The NJQRP Club has provided this kit of parts and instructions to help guide you through *Manhattan-style* assembly of the Sniffer, and a theory of operation section that will help you understand the circuit fundamentals. We also describe common uses and operating techniques for this piece of test equipment. By assembling this simple kit you'll have an enjoyable homebrew experience using a popular construction technique and you'll end up with a very useful measurement device for years to come.

### BACKGROUND

The Field Strength Meter (FSM) has long been a mainstay in the area of antenna measurement out in the field. An FSM is actually just a very sensitive RF voltmeter that measures the relative field strength of radiated signals. The device senses (or sniffs!) a portion of the RF spectrum by means of a short whip antenna and "detects" the signals by rectifying and filtering them to indicate as a DC voltage on a sensitive meter. A simple block diagram of this arrangement is shown below.

There are no tuned circuits

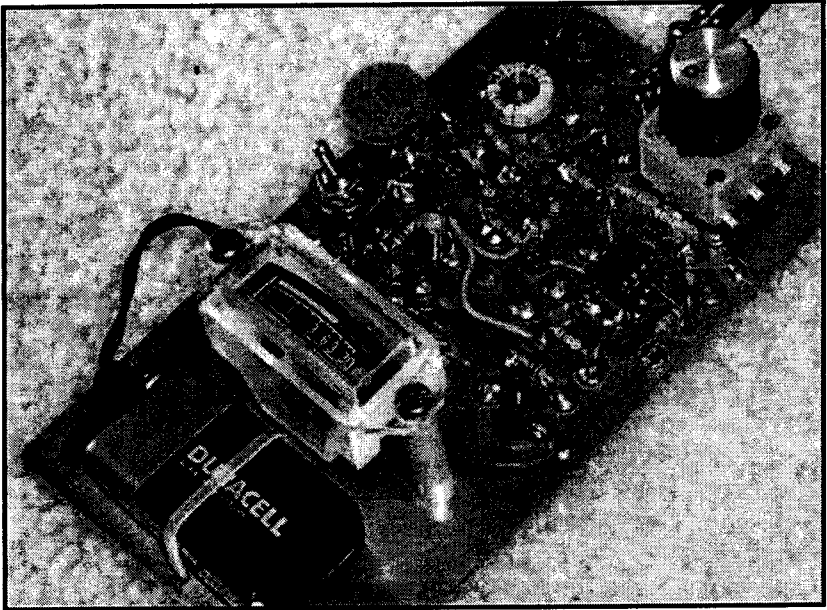

**Close up view of the construction Layout**

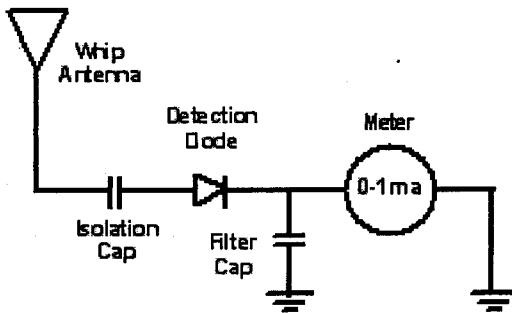

**Fig. 1 A simple Field Strength Meter**

used in this simplest example and thus a very wide range of frequencies may be measured without any tuning requirements. A drawback, however, is that this approach has

very low sensitivity – only strong signal register on the meter – and the selectivity is quite wide yielding an inability of the operator to distinguish which of many possible

signals are being measured.

Several modifications can be easily made to this simple circuit to provide improved sensitivity and increased utility across the HF spectrum.

**Selectivity** may be dramatically improved by adding a tuned circuit on the input of the FSM, between the antenna and the isolation capacitor. If the FSM is to be used on a specific and unchanging frequency – for example, on your favorite operating frequency of 7.040 MHz – a fixed parallel-resonant tuned circuit consisting of an inductor and capacitor may be used to filter out all other signals, be they nearby ham signals, AM broadcast stations or other man-made interference. The positive effect of this modification can be quite dramatic and greatly improve the device's usefulness.

If a single band of frequencies is of interest – perhaps the entire 40-meter ham band, or even several adjacent ham bands – a tunable filter may be placed on the input of the FSM to yield similar improvements in operation. The only drawback is there now is a need to manually tune this added selectivity to the specific frequency of interest ... but what ham among us has ever complained about having at least one knob on a project?! Seriously though, this simple manual control adds tremendous utility to the measurement device and it's worth its weight in gold.

The **sensitivity** of an FSM is

the result of a combination of the frequencies being measured, length of the whip antenna, frequency response of the detection diode and basic sensitivity of the meter. In fact, the sensitivity is also (positively) affected by using the tuned circuit discussed above for the input. In this case the narrower received bandwidth ultimately allows only the desired frequencies to be detected and registered on the meter.

Another common sensitivity improvement one can do is to amplify the DC signal produced by the detector diode and filter capacitor. By boosting this voltage you will ultimately be able to register a smaller detected signal on the meter. By adjusting this amplification, or the length of the whip antenna, or even de-tuning the parallel resonant circuit on the input, you can in effect control the sensitivity of the FSM to better read the relative RF field strengths of interest.

As it turns out, the NJQRP Sniffer provides each of these types of selectivity and sensitivity improvements to provide an extremely usable and low-cost measurement unit. ***So let's now get into actually building the Sniffer!***

#### **KIT CONTENTS**

Carefully unpack the bags and ensure that all of the components are present, as listed in Figure 2. The NJQRP volunteer kitting team has taken every reasonable step to ensure that everything is included. In the event that some-



QTY	Reference	Description
1	R1	Potentiometer, trimmer, 50K
8	R2, R3, R4, R5, R6, R7, R8, R9	Resistor, 100K, 1/4W
2	R12, R13	Resistor, 10K, 1/4W
1	R10	Resistor, 10M, 1/4W
1	R11	Resistor, 1K, 1/4W
3	D1, D2, D3	Diode, germanium, 1N34A
2	LED-1, LED-2	LED, T1
1	C1	Capacitor, dual 10-280pF, Polyvaricon
1	C2	Capacitor, 100pf, disc
1	C3	Capacitor, 0.1uF, disc
1	C4	Capacitor, 10uF, 16V, electrolytic
1	J1	Battery clip, 9V
1	J2	RCA phono jack
1	P1	PCA phono plug
1	L1	Inductor, 2.1uH, 23t on T50-6 toroid core (yellow)
1	L2	Inductor, 5.4uH, 34t on T50-2 toroid core (red)
1	Magnet Wire	46"
1	Whip	Copper wire, 12 ga., 6"
1	Socket	IC socket, 8-pin DIP, wire-wrap pins
1	U1	Integrated Circuit, LM358
1	M-1	Microammeter, 0-200ua
1	PCB board	PCB board, 2-sided, 3"x6"
1	pad strip	6" strip 3/16" wide 2-sided copper clad (for pads)
1	SW-1	Switch, slide, miniature

**Figure 2: Parts included in the Sniffer Kit**

thing is missing, please see if you might have a replacement in your junk box to help you along most quickly, or contact Dave Porter AA3UR ([aa3ur@njgrp-kits.net](mailto:aa3ur@njgrp-kits.net)) to request some assistance.

Note that you will need some other common materials to complete and/or customize your kit. The **parts not included** in the Sniffer Kit are ... a 9V battery, tie-wrap, knob/shaft/screw for the Polvaricon tuning capacitor, small lengths of hookup wire, mounting hardware for the meter, rubber feet for the bottom of the unit and glue for the *Manhattan-style* pads. Again, improvise from the materi-

als available in your junk box to make your kit a unique creation!

### **CONSTRUCTION**

The Sniffer Kit is constructed using *Manhattan-style* construction techniques, which has become quite popular among homebrewers today. One basically assembles the components in an open, free-form arrangement on a blank piece of copper-clad pcb material. The leads of resistors, capacitors and even IC sockets are soldered to little pads that are glued to the surface of the board, thus providing interconnection points that are isolated from the ground plane of the baseboard. This style of circuit as-

sembly lends itself well to an "open air" type of circuit with components that can be custom-arranged to fit specific enclosures and easily debugged or modified at a later time.

For the purposes of this Assembly Manual, we'll assume you have a basic understanding of the technique as we guide you through the steps necessary to build your Sniffer. Many articles have been published concerning Manhattan-style construction techniques – so if this is the first time you've tried using it, you might do some research in past issues of QRP Homebrewer, QRPP or QRP Quarterly magazines to learn more.

### **Preparing the Board**

In order to end up with the most attractive looking Sniffer when complete, you should first thoroughly remove the oxidation from the 6" x 3" copper-clad material supplied in the kit for the baseboard. Many homebrewers use a Brillo pad or some non-abrasive cleaner for the top and bottom copper surfaces. I often just lightly rub the surfaces with steel wool. Next you should wash the board with soap and water to remove any grease and oils present from handling. This will leave a very clean surface that is ideal for gluing on the pads. Finally, a light coat of clear lacquer may optionally be sprayed on to keep the board from oxidizing and turning brown again. Don't spray it on too thickly, as the pads won't stick that well and it'll be harder to solder the ground con-

nections to the baseboard.

### **Component Layout**

Only a little forethought is required to determine the arrangement of components on your clean baseboard. Here is where your individuality can come in! We've provided a template in Figure 13 that is very close to the way I built the prototype units pictured in this manual, but you could of course use your own arrangement to better suit the enclosure you have planned for the Sniffer, the size of your project, or perhaps to accommodate alternate components that you may wish to use from your junk box. Just draw out the physical components on a piece of graph paper and then use that as a guide for mounting the pads.

### **Marking the Pad Locations**

Carefully align your drawn layout diagram on top of the baseboard and hold it in place with tape or rubber cement. Using a sharp pen or the point of a hobby knife, place a small mark at the center of each pad on the drawing, pressing hard enough to mark through the paper and onto the baseboard. Don't use a center punch or otherwise dent the copper, as you want the baseboard surface as smooth as possible to best hold the pads when glued down. Remove the paper layout template and again mark each of the pad areas with a felt-tipped marker to better help you see each pad location. Be sure to also mark the locations for the screws/standoffs used to mount the meter,

and those used to hold down the battery.

### **Drill Holes**

You'll need to drill holes at the locations marked to mount the mater and battery.

### **Mounting the Pads**

You first need to create the pads by snipping off little pieces of the thin strip of copper-clad material supplied in the kit. Using a pair of side cutters, snip off pieces of the strip that would yield small rectangles of board material about 3/16" x 5/16". These will become the pads you'll glue down at each of the marked locations on the baseboard. Place a small drop of Super Glue at each marked location, and use the tip of needle nose pliers to firmly press the pad on that drop of glue. Keep applying pressure to the top of the pad for about 30 seconds. Do this gluing operation for each of the other pad locations on the baseboard.

*Note: Instead of gluing down pads, you could cut "isolated is-*

*lands" into the base board by using the popular NJQRP Islander Pad Cutter, a diamond-tipped end mill that cuts a 5mm diameter circle into the copper-clad material. I used this technique in building the Sniffer pictured in this Manual and it worked out just great. After taping the layout to the board, I merely used a small drill press chucked up with my Pad Cutter to cut through the copper surface at each of the locations, thus creating an isolating "moat" around each pad of copper. (See Note 1 at the end of the manual for Islander ordering information.*

**Preparing the Toroids** – It's a good idea to prepare the L1 and L2 inductors right up front and get these tedious toroid winding steps out of the way. It's really quite simple and most of you have likely done this many times before. **To create L1**, measure out about 20" of the magnet wire supplied in the kit and wind 23 turns through the **yellow T50-6 toroid core** as

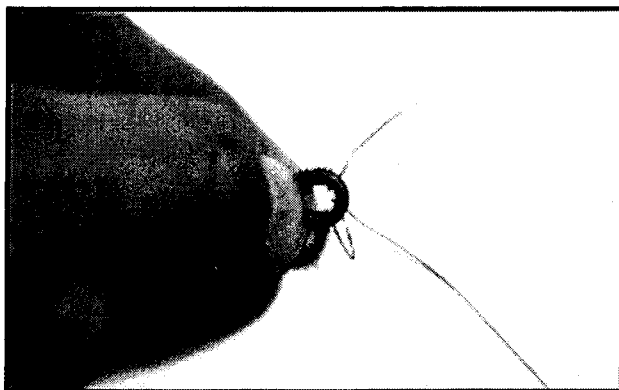

**Figure 3: Winding toroids for L1 and L2**

shown in Figure 3 below. Each time the wire passes through the center of the core counts as one turn. After placing 23 tightly-wound and equally-spaced turns around the core, snip off the end to leave about 1/2" leads sticking out. Scrape the enamel coating off the ends for about 1/4" and tin these exposed leads with your soldering iron. Do the same preparation for L2 by using the remaining length of magnet wire (about 26") and winding 34 turns on a red T50-2 toroid core.

### Attaching the Components

This is the fun part! Assuming that you gave each component enough room when laying out the pad locations, it should be a piece of cake to solder the parts to their respective nodes. One of the nice features of Manhattan-style assembly is that the physical circuit topology (i.e., the arrangement of components on the board) can often closely resemble the schematic diagram. This makes assembly and interconnection a simple matter of just following the schematic.

I'll provide a number of suggestions and hints for putting components onto the Sniffer baseboard. These are the steps and the order followed in constructing my units, but you could assemble yours in any manner whatsoever – which is yet another beauty of *Manhattan-style* construction!

Starting at the left-hand side of the schematic, which corresponds to the top of my board (as

shown in the photos), I attached the whip **antenna jack J1** to the board by tightly screwing on the nut to hold the ground lug, bending the ground lug at a 90-degree angle and then soldering the lug to the edge of the base board.

*Note: When soldering wires and component leads to the baseboard, it's necessary to hold your soldering iron against the baseboard for a tad longer than usual in order to "burn through" the light coating of clear lacquer that was suggested earlier. The same is true for soldering each of the island pads, if you used the Pad Cutter to create the pads. Pre-tinning all these pads before any component assembly can be done quickly and it helps in later when attaching each component lead.*

In order to mechanically strengthen the connection of J1, I soldered a piece of stiff wire from **J1 center conductor lug** down to the pad beneath that lug. This provided a two-point mechanical connection of the RCA phono jack, which proved to give it greater strength needed for the plugging and unplugging of the whip antenna plug P1.

I next attached the **Polyvaricon tuning capacitor C1** by gluing it to the baseboard as shown in Figure 4. I actually used a small plastic "spacer" to electrically isolate it from the ground plane just in case the little trimmer screws on the bottom were to touch the copper baseboard. The 1/2"-

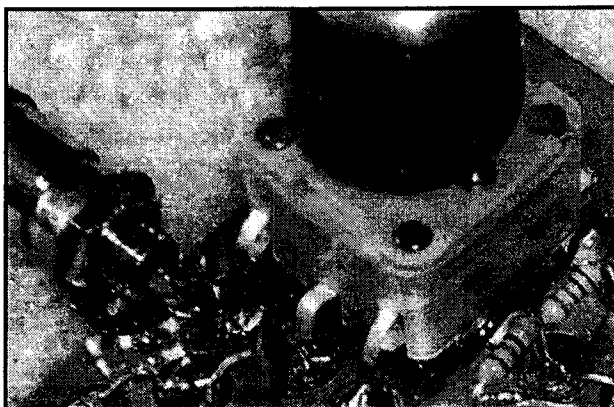

**Figure 4: Close-up view of mounting C1 and J1**

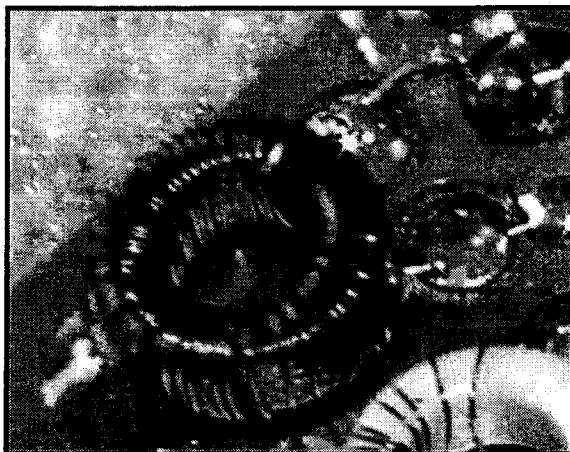

**Figure 5: Mounting the L1 and L2 toroids**



**Figure 6: Mounting components**

square plastic was cut from an old CD jewel case and glued on the bottom to the base board, and then C1 was glued to it. When soldering to the lugs of the capacitor, be sure to make a good solder joint. Tarnish or oxidation may be present on the lugs, which is a common occurrence on older parts from some manufacturers.

I next mounted the **L1 and L2 toroids** by gluing them to the base board as shown in the Layout and photo below. I actually used fast-curing epoxy to hold them in place against the base, although you could use many other forms of adhesive (e.g., RTV or silicon caulking material). Once the glue was cured and holding the toroids well in place, I just soldered the ends of the inductors over to the adjacent pads.

I then proceeded to **solder in many of the resistors, capacitors and interconnecting wires** in the center of the baseboard. There's nothing really tricky about attaching these components except that more evenly-spaced and orthogonal component orientations tend to make the board look like a work of art when complete. (For outstanding examples of such craftsmanship, see Jim Kortge's K8IQY project pages on the Internet at [www.qsl.net/k8iqy](http://www.qsl.net/k8iqy)). I'm normally in a hurry to get my projects completed and don't take too much time to make things pretty, as you'll note in the photos ... but it doesn't look too bad either! You

can achieve a polished look by just bending the component leads in a uniform way, placing them at right angles to the pads, and routing your interconnecting wires at right angles along the baseboard.

**Mounting the IC socket** might seem like a daunting task, but not really! If you were careful in placing the small pads as indicated in the Parts Layout diagram, all you then need to do is slightly bend the socket leads outward at an angle and cut them off evenly before soldering to the pads.



**Figure 7: Mounting the IC socket**

**Trim pot R1** has three pins coming out the bottom of its case. Carefully bend those leads outward to line up with the three pads in your Parts Layout diagram. Just solder them to the pads and you'll have a relatively solid mounting for this component. There's not too much of a need to adjust this potentiometer once set, so it won't be undergoing undue amounts of mechanical stress.

*Note: Many times a component has one of its leads "going to ground", meaning that the lead must be soldered to the common ground plane in the project: the copper plane of the baseboard. The trim pot is such an example, whereby one end of the fixed resistor gets grounded. In these cases, a separate pad is not necessary and you can just solder the lead to the baseboard. Sometimes, however, a pad may be useful to use even for this ground connection because of the physical limitations or orientation of the component lead. Again using this trim pot as an example, it's useful to employ a third pad for the grounded end of the pot because the leads are all at the same level. In this case, just put an extra wire (like a scrap lead nipped off from a resistor) from that third pad to the ground plane*

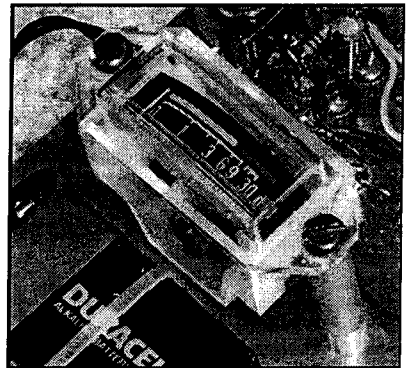

**Figure 8: Mounting the trim pot**

**Power switch S1** is the next big component I mounted to the baseboard. Several different styles of switches are supplied in

the Sniffer kits, so yours may be different than the one shown in these photos. Regardless of style, the main idea is to solder the two "hot" switch lugs directly to pads, and the unused "cold" switch lugs directly to the baseboard. It's a good idea to solder the lugs in a manner that gives solid mechanical support since you'll often be switching the unit on and off. Be creative and mount your switch in a convenient location and orientation!

The **meter** is mounted to my baseboard using two thin 1.5" machine screws through some standoffs grabbed from the junk box. Homebrew standoffs could be fabricated from the tube of a plastic BIC pen. Just cut off equal lengths set of the pen's tube and you'll be all set. (Remember to remove the inner ink tube or you'll have a real mess on your hands!) When wiring to the meter terminals on the bottom, be sure to observe the polarity as indicted in the plastic by the lugs.



**Figure 9: Mounting the meter on standoffs**

The last major item to be mounted on the baseboard was the **9V battery**. I secured it with a tie-wrap around the battery and through the holes in the baseboard on either side of the battery. Instead of using a tie-wrap to hold down the battery, you could just use a piece of stiff wire.

While still in the construction mood, I made up my simple **whip antenna** by taking the short length of #12 copper wire and soldering it to the center conductor of plug P1. I slid the wire into the rear of the tube of the RCA phono plug and soldered it in place. I then slid the plastic shell over the wire and screwed it onto the threads of P1. Lastly, I bent the wire upward at a 90-degree angle as shown in the photos, which also tended lock the plastic shell on the threads of P1.

Some **rubber feet** were scrounged from my junk box and attached to the bottom of the baseboard to finish off the mechanical assembly of the Sniffer. This provided a convenient, non-skid base when the unit sits on the table.

## TEST

Chances are your newly-assembled Sniffer won't work when you first apply power – at least that's been my own experience with projects! But don't worry, we'll outline some easy steps that you can follow to resolve possible problems just by using a VOM (volt-ohmmeter).

### 1) Check your voltages –

Make sure you have around 8.5-to-

9 volts coming from the battery, as measured on the Inward" side of the power switch when in the ON position. Then check to see that you have the same voltage on U1 pin 8, at the wiper of the trip pot R1, and at the LED resistors R12 and R13. These LEDs should be faintly illuminated — turn your room lights off to ensure the LEDs are indeed dimly glowing. The LEDs should each have about 1.2V across them. If any of these conditions are not as indicated, you've got a basic problem in your DC power or distribution wiring and you'll need to resolve this before trying anything else.

### 2) Check diode polarity –

Measure the voltage at the D1-R2 junction, and the D2-R4 junction. Each one should be about 2.4 volts or so – if not, the diodes are likely in backwards. This is an important checkpoint because if the diodes are connected backwards, the main function of the Sniffer (i.e., RF detection) will not work.

### 3) Adjusting the Sniffer –

Disconnect the whip antenna and ensure that you are not in any direct RF fields. Monitor the output of the first amplifier at U1 pin 1 while turning the trim pot across its range. You should see a minimum voltage dip around the midpoint of rotation, probably in the millivolt range, indicating that the detector bridge is presenting the proper voltages to the op amp. You can monitor the output of the second amplifier on U1 pin 7 and see a similar



dip occur, but at a higher voltage. And finally, you should see the meter indicate a minimum reading (very close to zero, or no movement) when the trim pot is at the "dip" position. If any of these conditions are not as described, you have a wiring problem that will need to be resolved for the Sniffer to work properly.

#### **4) Check out the Sniffer with known frequency sources**

– Connect the whip antenna, turn the power ON and turn on a transmitter at a known frequency, say 7.040, while using a dummy load. You can try using the rig in your shack, or perhaps any of the QRP kits you've built up over the years – FB40, Snap, Tuna Tin II, etc. Any of these rigs should produce enough RF for your Sniffer to detect and give a meter indication. (Some dummy loads are pretty well shielded and you might need to hang a clip lead from the Sniffer's whip over by the dummy load on your rig if you're having trouble getting a reading.) While keying the transmitter, rotate the Polyvaricon capacitor C1 until you see a reading on the meter. If the meter immediately pins to the right, try reducing the power of your transmitter, move farther away from the rig, or turn C1 a bit off resonance. This should allow you see relative changes in the RF field when other conditions are changed, like moving to a different location or angle of the whip antenna. Switch the transmitter to other bands and no-

tice that the meter peaks at different settings of the tuning cap. The Sniffer is able to detect RF fields across all the ham bands from 80m through 10m. If operation is not as described, you likely have a problem in your "front end" wiring around the variable capacitor and toroid inductors. Check that wiring, the number of turns on the L1/L2 toroid cores, and proper connection of terminal lugs of C1.

#### **USAGE**

As hopefully you've found in the previous checkout section, it's not really complicated at all to operate a field strength meter. The basic principle is to read the relative strength of an RF field in order to determine field patterns emanating from antennas, look for stray RF fields in unexpected places, or determine optimum settings of transmitters by reading relative changes in the resultant RF field. Once you get the hang of adjusting the Sniffer's sensitivity and selectivity so as to isolate the desired signal from background interference, you'll find the device a pleasure to use. Sometimes increasing the length of the whip antenna helps in increasing its sensitivity, and other times shortening the antenna helps to reduce its sensitivity when used in higher power RF fields. In this regard, a telescoping antenna would be a very useful improvement over the fixed-length whip.

To make the Sniffer more rugged and less prone to stray sig-

nals or body interference, it would be good to enclose the device in a metal enclosure. This would protect the circuit components from mechanical stresses and enable you to toss the unit into a backpack or tool chest when measuring out in the backyard or while on Field Day. The creativity that hams demonstrate in packaging their projects is a great source of amazement to me – how will you bundle up your Sniffer?!

### **SNIFFER THEORY OF OPERATION**

The Sniffer design is based on the simple FSM described at the start of this manual, but N2CX added a variable tuned circuit on the input to provide continuously variable center frequency for the selectivity throughout select HF ham bands. His design also provides an enhanced detector scheme for added sensitivity, and a two-stage buffer-amplifier to boost the very low detected signals to give the Sniffer great sensitivity. Refer to the Sniffer schematic (Figure 12) as we go through the nitty-gritty circuit description in this section.

Okay, let's start at the very beginning – which is indeed a very good place to start! (With apologies to Julie Andrews and the Von Trapp family.) Pretend you're a 7.040 MHz QRP-level RF signal having been just launched from that nifty new antenna in your backyard. The short 4"-6" whip antenna of the FSM *sniffs* the nearby RF fields emanating from the antenna

and you (the signal) slide down the whip and into the **L1-C1 parallel tuned circuit**.

By the way, if you use a **whip antenna** longer than 6", you may damage the meter because too many of your buddies (other signals) would be gathered by the antenna and will all be detected, amplified and registered on the meter, thus over-driving the sensitive meter coil. Indeed by using a longer whip, the Sniffer will respond better to far-off RF source – but those nearer/stronger ones will really pin the meter. A helpful improvement in constructing the Sniffer would be to use a telescoping whip antenna (like one from Radio Shack, used for walkie-talkies) to give an added control of sensitivity.

Okay, back to the **tuned input circuit**. You (the 40-meter signal being measured) have just slid into a rather unusual variable tuned circuit consisting of L1 and C1. The actual circuit components are a dual-section Polyvaricon tuning capacitor (like the kind used to tune FM radios and the EMTECH ZM-2 antenna tuners) and two toroidal inductors. The tuned circuit is resonant at two frequencies simultaneously, eliminating the need for a band switching mechanism while tuning from 80 through 10 meters. It may also be intentionally off-tuned to reduce sensitivity. The frequency plots and the table of resonant frequencies show the frequency ranges achievable with this tuned input circuit. In a way of speaking,

this tuned input circuit was made just for you (the 7.040 MHz signal) when the variable capacitor is adjusted to be resonant in the 40m band. When this is the case, it rejects all other signals and lets you pass on through to the next stage. This characteristic is called *selectivity* because only certain signals, those at the circuit resonance are allowed to pass. In this way, other interfering signals would be rejected and would not have the ability to get further into the FSM to affect its measurements. Only the signals of interest get through. This should make you feel pretty important!

A **100 pf capacitor, C2**, couples the RF signals into the diode detector while blocking DC. This component keeps DC current from coming down the R1-R3 path and getting into the tuned circuit, thus unbalancing the diode detectors (described next). So in essence, you (the RF signal) are able to slide on through the DC blocking capacitor as if it were not there and you then head on into the detector.

"Detection", the heart of all field strength meters, can be defined as the translation or demodulation of radio frequency energy to its original form. In the case of antenna field measurement with an FSM, the transmitted signal often is a continuous wave (CW) RF signal and the detection process in the FSM rectifies the RF sinusoidal waveform in a diode junction. A ca-

pacitor then smoothes out this half-wave signal to produce a DC voltage that is proportional to the strength (amplitude) of the original RF signal. This is the basic operation shown in the simple FSM diagram shown in Figure 1.

However in the actual Sniffer circuit, N2CX wanted to provide a more sensitive detection scheme, so he utilized two diodes and arranged them in a bridge-like configuration. These diode detectors, **D1 and D2**, form a balanced network in conjunction with bias resistors **R2 and R4** to provide equal voltages at the anode mid-points of the bridge. **Trim pot R1** gives the operator a means to fine tune the current flowing through each leg of the bridge, thus getting the anode of each diode to be precisely the same voltage. *Now here's the key point* – when the sinusoidal RF signal is presented to one of the diodes in the bridge, the rectified voltage produces an imbalance in the bridge that is able to be sensed, amplified and registered on a meter later downstream. Further helping the cause for sensitivity, N2CX employed germanium diodes that have lower forward-conduction voltages of 0.3V (as compared to silicon diodes). Thus the DC biasing provided in the bridge sets the diodes to a condition that yields very sensitive RF detection whenever RF signals are presented to one of the diodes.

So this detection process actually turns *you* from a radio frequency sinusoidal waveform into a

half-wave signal. But I bet you still feel the same, albeit perhaps just half the person you were at the antenna, right? Well, to quote George W. Bush: "Things are going to change from this point forward!"

The DC voltage imbalance in the detector bridge is very small – often less than 1 millivolt – when *you* (the QRP RF signals) are presented to one side of the bridge. In the simple FSM circuit of Figure 1, this would be far too small to effectively register on a meter ... *you'd* have a real hard time pushing that little needle up to a proper reading! N2CX realized this and came to your rescue by providing several stages of amplification to give *you* additional strength to do the job.

The key to amplifying that small microvolt signal lies in extracting it from that sensitive detector bridge without affecting its operation. This is accomplished by employing **low-power op amp U1** which has a very high impedance input impedance. U1a is configured as a *differential amplifier*, meaning that its two input voltages are compared and just the difference between them. In this way, the amplifier is able to internally calculate the instantaneous difference between the steady reference DC bias voltage on the anode of diode D1 (which is presented to the inverting input on U1 pin 2) and the detected RF signal riding on top of that same reference DC bias voltage present on the anode of D2 and presented to the non-inverting input on U1 pin

3. That's a complicated sentence, but suffice it to say that the reference diode voltage is subtracted from the diode voltage on which *you* (the signal) are riding, and the result coming from the output of the op amp is precisely you, that microvolt-level detected RF signal.

There is no amplification of the detected signal in this first stage, since U1a is configured with R4-thru-R7 having the same values. This effectively programs the op amp to have *unity gain*. So this first half of U1 serves a critical role in the process by determining the imbalance in the bridge when a signal is present, and because of its high input impedance it extracts that difference without affecting the bridge's operation.

We should mention here mention here that **a reference level of 1.5V is generated by LED-2** in order to properly bias U1 and eliminate the need for a dual-voltage power supply. This is accomplished with the circuit components **R13, LED-2 and C4**. The constant current flowing through the resistor and LED (approximately 780 ua) forward biases the diode junction in the LED to create a 1.5V voltage drop. The 10 uF electrolytic capacitor gives this bias source a low AC impedance for noise elimination and stability. That constant voltage is applied to the non-inverting inputs of both U1a and U1b, and to the diode detectors to eliminate the need for a dual-voltage power supply.

It's important to note here, as mentioned above, that the output of U1a presents the *difference* of the reference diode voltage and the signal diode voltage, which results in the microvolt-level detected signal being output on U1a pin 1 ... as measured against the reference voltage coming from LED-2. If one were to measure the U1a output pin referenced instead to ground, that 1.5V reference voltage would be seen carrying the microvolt signal.

By the way, you might wonder where the capacitor is in the Sniffer circuits, as compared to the simple detector of Figure 1. After all, you need that cap to filter the half-wave rectified signal in order to create a DC level, right? Yes indeed Scarlet, you are right, but the stray capacitances in the circuit and inherent response times of the op amp actually provide that capacitance, and the outputs of the op amps are indeed filtered DC levels for all intents and purposes.

Okay, back to our story of you ... you are the little detected RF signal is coming out of the first stage of buffering and now is at the output of U1, looking like a 500uV signal sitting on a constant 1.5V level. N2CX next worked some magic to amplify you 100-fold by squirting you into yet another amplifier – **the second half of the low-power op amp U1**. This amplifier has a 100 K-ohm input resistor **R8** and a 10 megohm feedback resistor **R10** which programs the

U1b to multiply the input signal by 100. The equation to determine the output of this kind of amplifier is:

$$\mathbf{Vout = Vin \times Rf / Ri,}$$

where Rf is the feedback resistor R10 and Ri is the input resistor R8. But you recall that the microvolt detected signal is riding atop a 1.5V DC voltage coming out of the first amplifier, right? We don't want to amplify this DC voltage, but only the small detected signal.

N2CX configured **U1b as a differential amplifier** as well and applied that 1.5V reference bias voltage coming from LED-2 to the non-inverting input U1 pin 5. The net effect of this configuration is that the constant DC level on which the microvolt detected signal is riding is the only signal to get amplified by 100. Thus, the effective input voltage "Vin" to U1b noted in the equation above is actually:

**Vin(b) = (Vout(a) – 1.5) x Rf/Ri** where, Vout(a) is the microvolt signal being measured riding atop the 1.5V constant level, and Vin(b) is the combined effective input voltage to U1b. Thus you can see that it is again the *difference* that gets amplified by U1b, just like the operation of the U1a stage before it.

So at this point, you (the detected signal) have been amplified by 100 and now have been strengthened enough to drive the meter. Feel pretty powerful? You should! Once a microvolt signal riding along on a DC bias, you are now a beefy volt-level signal all by yourself. You are next sent through

a **current limiting resistor R11**, through the **meter M1**, and finally down to ground potential through **LED-1**. We'll next describe how these components interact.

Recall that the meter reads full scale when the current going through it is 200  $\mu$ A. We want to be sure that we don't burn out the meter by pumping any more current than that amount, so we use a current limiting resistor of 1 K-ohm to do the job. This value was selected by considering the basic  $V=IR$  relationship and knowing that *you* (the signal) have now grown up to be about 7 volts at most (for example) coming out of U1b, and that LED-1 has a forward voltage drop of about 1.5V. The maximum current able to be supplied through the meter then would be:

$I_{max} = (7-1.5) / 1000 = 5500 \mu A$   
which would clearly smoke the meter in a heartbeat. (How about that for *you* being a powerful signal!) But we'll keep the maximum current at this level in order to ensure that we achieve good sensitivity down in the lower range of interest for the detected signals, and in order to ensure that we keep LED-1 turned on enough to keep LED-1 turned on. N2CX used an LED in this circuit to provide the 1.5V offset voltage needed to allow the meter to read zero with no RF signal applied at the input of the Sniffer. Without the LED, the small, constant DC voltages coming through U1b due to slight differences in the reference voltage off

LED-2 and the DC level coming from U1a would prevent the meter from being able to be adjusted down to zero with no signal present. (Recall all the "about 1.5V" terminologies in the preceding discussions!)

The 10 K-ohm **resistor R12** coming right off the battery also supplies some current to LED-1 to help establish this level, but the signal being measured really supplies the bulk of the current that provides its forward voltage. In fact, you can even see the LED's intensity brighten with a strong signal is being measured!

As further insurance that we don't burn out the meter, **diode D3** is connected across the meter terminals. When the measured voltage (*you*) exceeds the diode's forward voltage point, and it turns on to shunt current away from the meter. Thus if the operator inadvertently misadjusts the detector bias trimmer, or attempts to measure a whopping big signal, the meter will likely peg over to its maximum extreme but it won't be destroyed.

So that's the Story of *You* – how *you* initially get caught by the whip antenna, slide down and through the tuned input filter, get detected, amplified and turned into a DC voltage in order to push a little needle of a meter to indicate how relatively strong *You* are!

## CREDITS

This kit was made possible by the dedicated work and contributions of several very special people.

**Scott Gregson, KC7MAS**, the owner and operator of **EMTECH**, was very helpful to the NJQRP Club and its annual Atlanticon QRP Forum extravaganza by graciously providing the Polyvaricon tuning capacitors at a more-than-reasonable price. Without his help, this project would not have been able to come to fruition as the "Atlanticon Kit" this year.

**Doug Hendricks, KI6DS**, co-founder of the NorCal QRP Club and *teacher-extraordinaire*, was also instrumental in making this Sniffer FSM Kit happen. Doug provided the NJQRP with the beautiful meters used in the design, at a next-to-nothing price. Once again, thank you Doug!

**John Cawthorne, KE3S**, a very active member of the NJQRP Club and veteran of multiple kitting efforts, came through again for the club by spearheading the kitting and shipping activities for the Sniffer. With the able assistance of kitting captain and chief club honcho **Dave Porter, AA3UR**, John was able to get the Sniffer kitted and out to everyone in a timely and quality fashion.

**Joe Everhart, N2CX**, co-leader of the NJQRP Club and my best buddy, once again demonstrated his technical prowess and mastery of analog and RF circuitry by designing such a useful project for the NJQRP. Many hams are going to be happily Sniffing for years to come. Joe also provided a good deal of the technical descriptions

that I (N2APB) was able to put together in a usable manner for this manual.

## NOTES

1. The Islander Pad cutter is available for purchase from the NJQRP for \$9. Shipping is free to US and Canadian locations.

## NEED HELP?

If you have any problems or questions, please visit the online web pages for the Sniffer at [www.njqrp.org/sniffer](http://www.njqrp.org/sniffer). We've posted all the latest project information, tips & techniques for construction and usage, modifications for expanded or alternate use of the device, and the inevitable corrections to the circuit, components and manual. We'll share the findings and experiences of those who provide feedback in hopes of having all others benefit.

If, after checking the online Sniffer web pages, you find that you still have a question or problem, please feel free to send us an email describing your dilemma. Tell us as much as possible about the problem and we'll do our best to provide some guidance.

We hope you enjoy building and using the *Sniffer* field strength meter! Please let us know how it works out for you.

73,  
George Heron, N2APB  
[n2apb@amsat.org](mailto:n2apb@amsat.org)

2419 Feather Mae Ct., Forest Hill, MD 21050

Joe Everhart, N2CX  
[n2cx@voicenet.com](mailto:n2cx@voicenet.com)  
214 New Jersey Rd.,  
Brooklawn, NJ 08030  
Dave Porter, AA3UR [nigrp-](http://nigrp-)

[kits@comcast.net](mailto:kits@comcast.net)  
647 Middle Holland Rd.,  
Holland, PA 18966

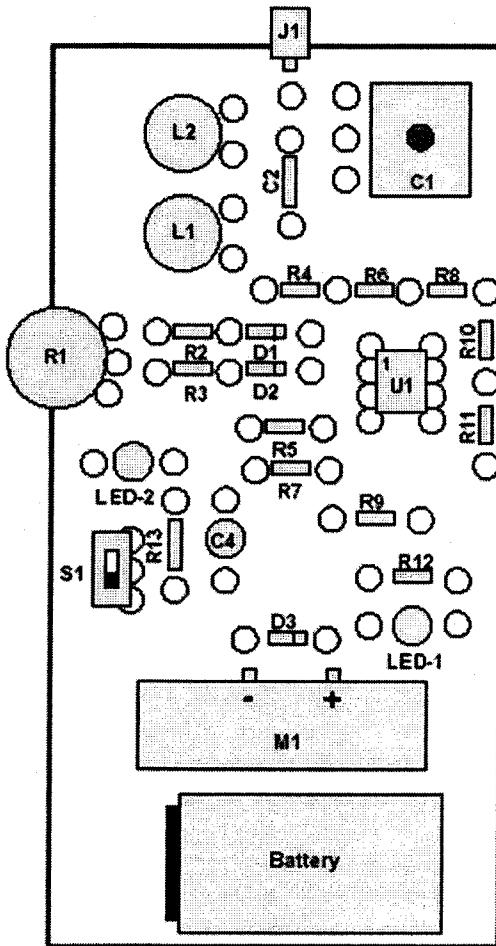

Possible Layout for Sniffer on One Board



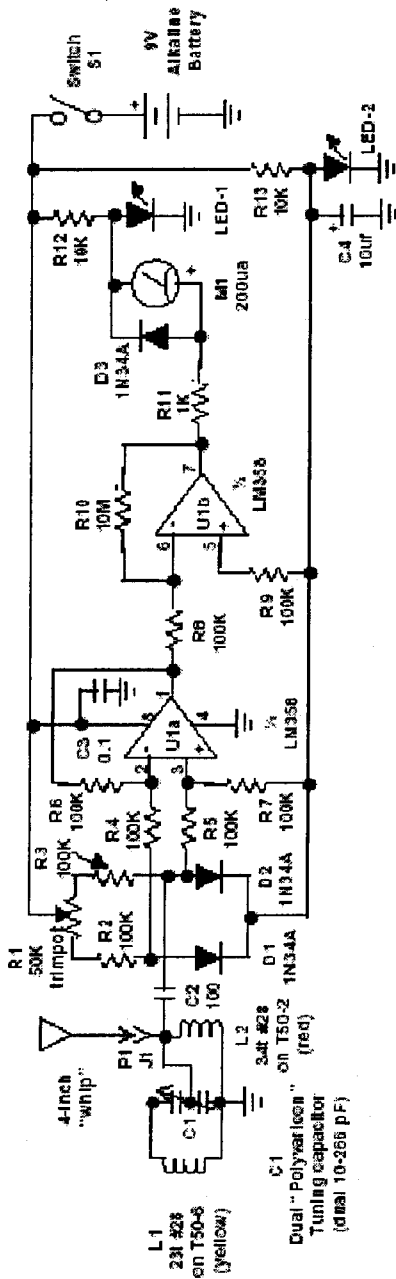

Schematic of the NJ Sniffer

# Build the St. Louis Quickie and Vest Pocket Vertical Antenna

by Dave Gauding, NF0R

*[Reprinted with permission from QRP Homebrewer #4, the Journal of the NJQRP Club]*

The St. Louis Vest Pocket Vertical (SLVPV) and the St. Louis Quickie Vertical (SLQ) are portable HF antennas. Both homebrew projects offer convenient low-band access for the QRP enthusiast interested in field operations.

These antennas can be built at a reasonable cost with off-the-shelf components and hand tools. The radiator designs differ but share a lightweight support fabricated from thin-wall fiberglass tubing. The mounting base and feedpoint assembly adapt to a wide-range of earth conditions.

The SLVPV features a high-performance St. Louis Coil covering 10-20M. This tapped air-wound coil design was introduced with the St. Louis Pocket Vertical. It con-

forms to traditional antenna theory. The SLQ uses the loaded ribbon cable radiator introduced by the St. Louis Express Vertical. This version of the radiator is resonant on 20M or may be tuned remotely with a transmatch for continuous 10-20M coverage. The design places emphasis on operating convenience in the field.

Eight St. Louis Radials configured as an eighth-wave on the lowest design frequency serve as an easily managed portable ground radial system.

These are free-standing verticals with installation and retrieval times measured in minutes. The support breaks-down into a 14 inch by 2 inch diameter package. The packed weight with accessories is 28 ounces and either antenna slips easily into a backpack, suitcase or briefcase.

<u>Qty</u>	<u>Materials, Parts &amp; Tools</u>	<u>SLQ Adjustment</u>
3 ea.	54.5 inch x .505 diameter fiberglass tubing. (Note 1)	
1 ea.	54.5 inch x .414 diameter fiberglass tubing (Note 1)	
2 ea.	3-1/2 inch x .411 diameter internal fiberglass coupler (Note 1)	
1 ea.	slotted-wall grommet edging, nylon, 12-3/4 inches (Note 2)	Delete
1 ea.	small brass cotter pin (or large fishing hook eye)	
1 ea.	doubled-sided printed circuit board, 2-3/4 inch square	
1 ea.	antenna jack, bulkhead (see construction notes)	
2 ea.	brass fishing swivel, size #05	
1 ea.	8 ft. solid copper wire or buss wire, #16	Delete
3 in.	#18 insulated wire, stranded	Delete
12 ft.	ribbon cable (flat computer cable), stranded, two conductor	Delete
12 ft.	ribbon cable (flat computer cable), stranded, three conductor	SLQ only
70 ft.	ribbon cable (flat computer cable), stranded, seven conductor	
5 ea.	small alligator clip, serrated jaw (Note 3)	1 ea.

8 ea.	medium alligator clip, serrated jaw, (Note 3)	
1 ea.	micro alligator clip, smooth jaw (Note 3)	Delete
1 ea.	heatshrink tubing, 1/8 inch diameter, 3/4 inch length	SLQ only
16 ea.	heatshrink tubing, 3/16 inch diameter, 3/4 inch length	10 ea.
2 in.	brass tubing, 3/32 inch diameter (Note 4)	Delete
4 in.	cardboard mailing tube, 1-1/4 inch diameter, 1/8 inch wall (Note 7)	Delete
1 ea.	barn nail, 6 inch length or 3/16 inch diameter equivalent	
8 ea.	2-56 x 3/8 inch machine screw	Delete
8 ea.	2-56 nut	Delete
24 ea.	2-56 washer (#2 flat washer)	Delete
1 ea.	Goop® sealant/adhesive, 3.7 ounce tube (Note 5)	Delete
1 ea.	two-part epoxy cement kit (5-10 minute work-time)	
1 ea.	drill bit, 1/16 inch diameter	
1 ea.	drill bit, 5/64 inch diameter	
1 ea.	drill bit, 1/4 inch diameter	
1 ea.	drill bit, #10	
1 ea.	drill blank, #10 (3-5/8 inch typ.)	
1 ea.	tapered reamer, 1/2 inch -13mm diameter	
1 ea.	aluminum miter box (Note 4)	
1 ea.	mini-hacksaw, 32-TPI blade (Note 6)	

#### Other Hand Tools & Supplies

Standard hacksaw, files(s), fine emery paper, steel wool, combination square, wire cutters, needle-nose pliers, small screwdriver(s), ruler, tape measure, masking tape, soldering iron, solder, extra medium alligator clips, cellophane tape, isopropyl alcohol and a lubricant. Optional items include a hobby saw, nibbler, cartridge de-burring tool, clamps and

a 1/16 inch drill bit.

#### Support Construction

1. Using the fine pitch mini-hacksaw trim the .505 fiberglass tubing into one 14 inch section and ten 12 inch sections. Use the miter box to produce a square cut. Rotate the tubing while cutting to control splintering. Finish the trimmed edges inside and out with a tapered reamer and emery paper.

2. Trim ten 2-1/2 inch ferrules from .414 tubing and finish as above. Mark a reference line 1/2 inch from the end of each ferrule. Using the 1/16 inch bit drill four random holes in the ferrule where it will overlap the tubing. The fit between the non-porous parts is very tight and the

additional holes help the cement establish a permanent bond.

3. Apply cement to the prepared end of a ferrule. Insert into a 12 inch section allowing 2 inches of the ferrule to project from the assembly. Repeat for all 12 inch sections. Cure overnight.

4. Trim a 1/2 inch ferrule from remaining stock. Square the end and cement flush into the top of the 14 inch tube. This is now the tip section and holds the cotter-pin eye for the upper radiator wire.

5. Drill a hole 3/8 inch from the top edge to match the diameter of the cotter pin. The hole should pass through both sides of the tubing. Trim so the eye projects just far

enough to accept the #05 fishing swivel holding the upper radiator. Install with cement.

### **Base Mount Construction**

1. Trim two 5 inch sections of .505 tubing. Trim two 2-1/2 inch .414 ferrules. Drill four cement reinforcement holes 1/2 inch from one end of each ferrule using the 1/16 inch bit.

2. Using a file bevel/sharpen one end of a 3-1/2 inch .411 fiberglass coupler to a 45 degree angle. Now trim a second .411 coupler to 3 inches. Then drill a eight randomly spaced 1/16 inch holes in this coupler to serve as cement channels.

3. A 5 inch .505 tube serves as the foundation for the base mount. Begin test fitting the components by inserting the 3-1/2 inch coupler into the base of the tube leaving 2 inches of the beveled end exposed. Add the 3 inch coupler above. Then fit a .414 ferrule on top leaving 2 inches exposed.

4. Cut the head off the barn nail. Sharpen the end by filing down each of the facets. Roughen the nail shank with a file to aid the cementing process. This nail will be installed in the beveled end of the coupler and serves as a mounting spike.

5. Finish the test fitting by adding the remaining .414 ferrule to the second .505 tube leaving 2 inches exposed. This sub-assembly serves as a protective shield for the mounting spike during storage. When re-installed on the top of the mounting base it becomes a

feedpoint extender.

6. Completing the base mount assembly is a two-part process. Begin by cementing the barn nail into the beveled coupler. The overlap is approximately one inch. Insure the sharpened tip extends only to the end the base mount's protective shield. Center the nail and support the tip-end with a jig made from scrap .411 coupler. Allow the cement to cure overnight.

7. Add extra cement inside the bore of the beveled coupler to reinforce the fiberglass rod above the mounting spike. Now re-assemble and cement all base mount parts insuring the internal components are butted firmly against each other. Cure this completed assembly overnight.

8. Drill a #10 hole through the body of the base mount. Center 1/2 inch above the edge of the overlap between the lower .411 fiberglass coupler and the main tube of the base mount. A snug fit is preferable so one pass with the drill is usually sufficient.

9. The #10 drill blank serves as a horizontal installation rod for a "foot-powered" base mount. The sharpened base pin followed by a tapered step helps the mount adapt to a variety of soil conditions.

### **Feedpoint Construction**

1. Trim a 2-3/4 inch diameter disk (circle, square, hexagon, etc.) from double-sided printed circuit board material. Drill a 1/4 inch hole in the center. Use a tapered reamer for enlarging and finishing. The feedpoint disk should have a fric-

tion fit along the base mount ferule. Now drill another hole in the disk for the bulkhead antenna jack and finish.

2. Form a 1/4 inch diameter two turn loop from #16 wire and include an 1/8 inch lead. Solder this lead into the solder cup of the jack. The loop serves as a solid attachment point for the alligator clip terminating the lower radiator.

3. Polish both sides of the pcb material with steel wool. Install the antenna jack firmly with a toothed or split-ring washer to ground both sides of the disk. The portable radials attach to this assembly using alligator clips. The covered feedpoint offers some wet weather protection for the coaxial connection.

### **SLVPV Tapped Air-Wound Coil Construction**

1. The SLVPV features a modified St. Louis Coil for 10-20M built on a 1-1/4 inch diameter cardboard mailing tube form. The diameter and length of the tapped coil can be changed to meet builder requirements. No alternate coil winding data is available.

2. With a diagonal cutter trim four grommets containing twenty-one complete notches. Using the 5/64 inch bit drill holes for the 2-56 attachment hardware in the outboard notches in the top and bottom of each grommet. Now drill additional holes in the second bays of grommets number 1 and number 3. These holes are identified as points A & B and points C & D in the dia-

gram. The letters mark the locations of the horizontal coil supports.

3. Locate equidistant positions around the mailing tube for the four grommets. Layout vertical guidelines using a combination square. Then drill twelve matching holes in the tube with the 5/64 inch drill using each grommet as a separate template. Now install the grommets with 2-56 hardware using the outside holes at the top and bottom of each grommet.

4. Place two washers between the grommet and the coil form. Place one washer between the nut and the coil form. Removing the stacked washers later helps to ease the completed coil off the cardboard without damage. The coil form is re-usable.

5. Attach 7 feet of the #16 wire to a solid object. Keep tension on the wire while turns are placed on the coil. The wire should be taut but not so tight as to distort the grommets.

6. The following instructions are for a right hand coil. The starting point is on the left side of the form. Push the wire through the locating hole at point A. Later trim the wire to project 1/4 inch inside the cardboard. Begin winding the coil clockwise after making a tight 90 degree turn to lock the wire in place. The stub will serve as the attachment point for the upper horizontal coil support.

7. Continue winding the coil towards the right side of the form placing uniform pressure on the

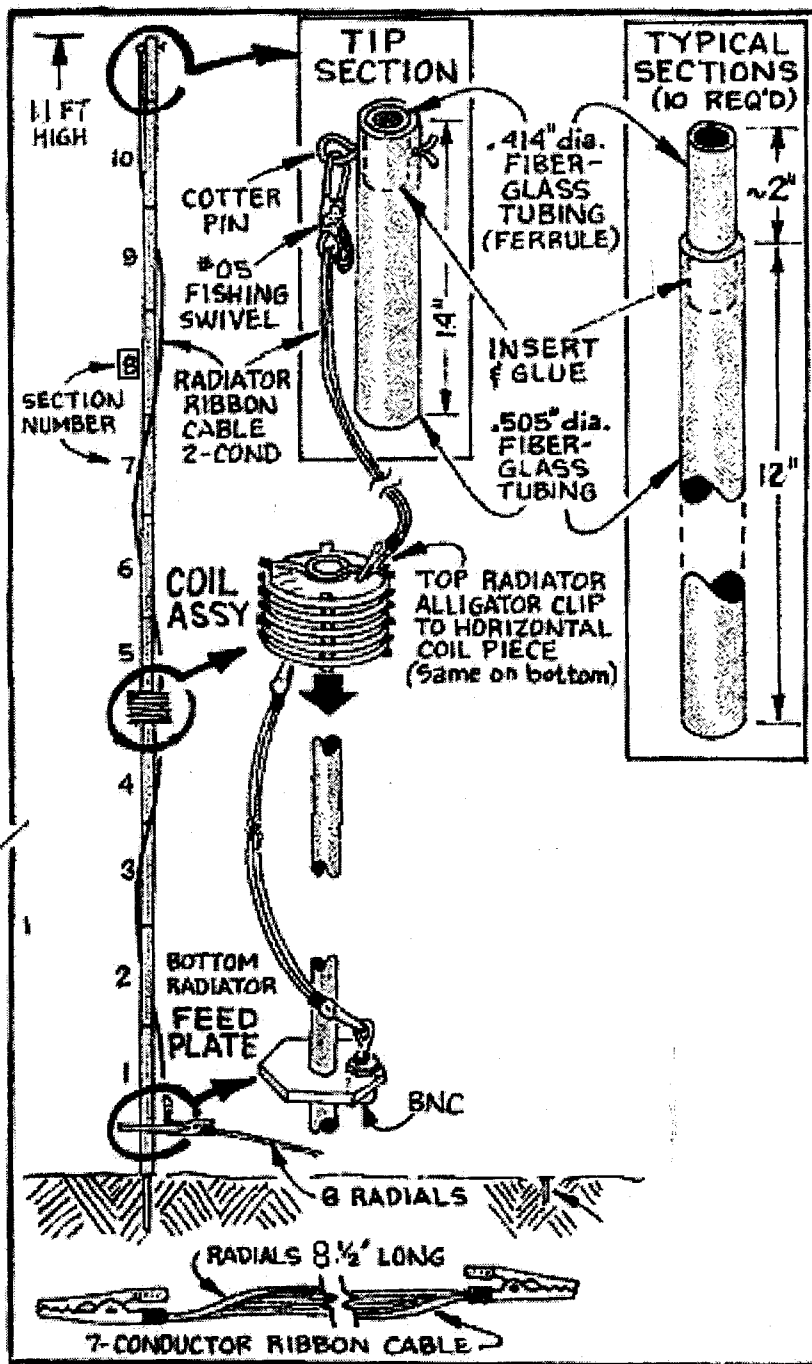

wire. Drop down one notch each time the wire meets itself. Inspect to insure the wire is positioned firmly in the bottom of each notch.

**8.** Finish the winding by trimming the wire 1 inch past grommet 3. Then bend the wire into a 90 degree angle at point C and push the wire through the opening. Pull the wire taut using a pliers. Trim the wire so it projects 1/4 inch inside the coil form. This stub will serve as an attachment point for the horizontal support at the bottom of the coil and the tap wire assembly.

**9.** Install the applicator tip on the Goop tube. Cut off the end of the tip at the first step. Apply a generous bead of the adhesive on top of the turns inside grommet 1. The rule-of-thumb for bead size is approximately the width of the grommet before the adhesive starts to settle. Press the Goop in place if necessary and create a depression in the adhesive by running a well-wetted thumb along the filled grommet. Avoid putting adhesive over the holes at points A & B and C & D and beyond at this time.

**10.** Now rest the upper edges of the nylon grommet under a 100W light bulb positioned horizontally. Slide the grommet back and forth so the Goop is exposed to heat. Several slow full-length passes over a sixty-second period are sufficient. The warmed adhesive will pass completely through the coil wire and onto the body of the grommet to create the bond. Repeat for each grommet. Cure for twenty-four hours

before handling.

**11.** Remove the coil attachment screws. Lift the ends of the grommets and slide the stacked washers free with a thin screwdriver blade. Push the wire stub at point A and point C outwards until they are just clear of the coil form. The fit between the coil and the form will be tight. Hold the coil in one hand and with the other gently twist the form free with a pliers. Then bend both wire stubs back into position.

**12.** If it is difficult to separate the coil from the form score the mailing tube internally with a fine hack saw. First remove the blade, pass it through the coil and then re-install on the frame. It is not necessary to cut completely through the cardboard. Using a screwdriver passed between turns gently bend one edge of the cut inwards to reduce friction. Then remove the coil.

**13.** The coil supports are fabricated from a single piece of #16 wire. For the lower support start with 5 inches of wire. Bend two turns around a .414 ferrule to create a coil-centering ring. Continue until the ends of the wire form a 300 degree angle. Using a pliers bend the wire ends backwards until the extensions are opposite each other on the ring and pre-trim to 1/2 inch. Repeat this procedure for the upper coil support using .505 tubing for the coil former. Confirm the fit on the tube and ferrule. Then squeeze the turns together with alligator clips and solder closed.

**14.** Using the mini-hack saw trim

four 1/4 inch lengths of 3/32 inch brass tubing. These will serve as couplers/reinforcements the horizontal coil support wires as well as solid attachment points for the alligator clips terminating the upper and lower radiators.

**15.** For the lower horizontal support begin by positioning the .414 coil-centering ring so the lower step of the pre-formed wire meets with the end of the coil at point C. Now trim the coil stub and the coil-centering ring stub to accept a brass coupler. Center the loop in the coil and add a coupler to the opposite side. The upper end of the horizontal support wire can project temporarily past the grommet at point D.

**16.** Heatsink the previously soldered lower horizontal support assembly with alligator clips. Confirm that the loop is centered in the coil and solder the brass couplers to the wires. Trim excess wire flush with the grommet at point D. Repeat these procedures for the upper horizontal support wire.

**17.** Now file all soldered joints smooth. Fill the grommets at points A and C with Goop. Add Goop at point D to protect the first turn of the coil from accidentally contacting the tap's alligator clip at that point. After the adhesive cures trim off the unneeded grommet material.

**18.** The removable coil tap consists of 2-1/2 inches of #18 stranded wire, one small alligator clip and the micro-alligator clip. Add two sections of 3/16 heatshrink tubing to

the stripped wire. Position the finger-pieces of the clips so they are on the same side of the wire. Pass the wire through from the inside. Dress the strands on the outside of the clips and solder the joint. Heatshrink the connections.

**19.** The tap wire's small alligator clip is attached to the end of the horizontal coil support where the stub projects from the grommet at point D. The turns are tapped with the smooth-jawed micro clip.

**20.** The SLVPV coil has a measured inductance of 5.5 microhenries and a "Q" of 220. There are eighteen full-turns and two half-turns. The coil contains 6-1/2 feet of wire including the horizontal coil supports and detachable tap assembly.

### **SLVPV Radiator Construction**

**1.** Two shorted parallel conductors of ribbon cable are used for the upper and lower coil radiators. This wire configuration is lightweight, strong and resists tangling.

**2.** The upper radiator length varies according to the band and two are required. The table (Note 8) provides approximate tip-to-tip dimensions and coarse tap locations along the coil. Measure for the radiators after the fiberglass support and coil are in position overhead. For 20M and 17M install all tube sections and the tip section. For 15M, 12M and 10M use one tube section and the tip section.

**3.** Begin by soldering the #5 fishing swivels for the upper radiators. Attach the wire to the tip section



# BUILDING THE "ST. LOUIS COIL"

## ① MAKE GROMMET SPACERS

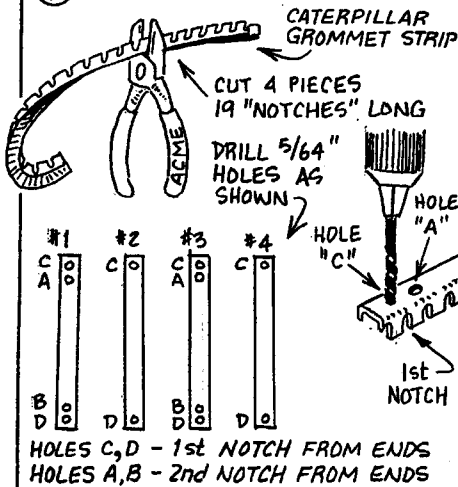

## ③ WINDING THE COIL

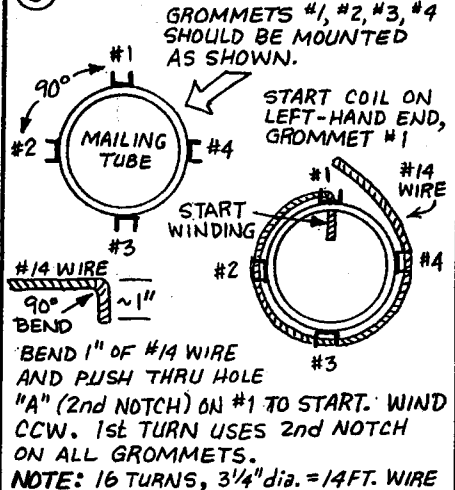

## ② PREPARE WINDING FORM

MOUNT GROMMETS #1-#4 ON A  $3/4$ " MAILING TUBE EVERY 90°. DRILL  $5/64$ " HOLES THRU TUBE WHERE HOLES A, B, C, D OCCUR. FASTEN GROMMETS WITH 2-56 HARDWARE THRU HOLES "C" & "D"

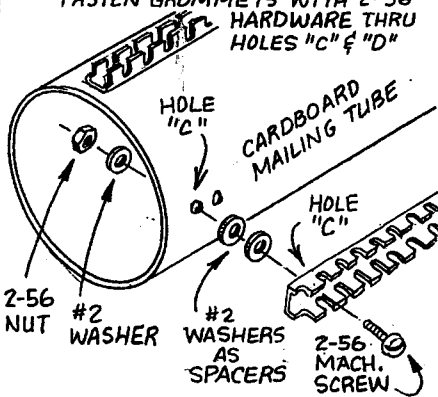

## ④ THE LAST TURN

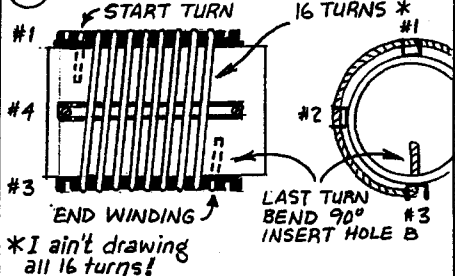

## ⑤ APPLY BEAD OF GOOP ADHESIVE ALONG TOP OF TURNS ON EACH GROMMET.



Designed by: Andy Becker, W0NVM and Dave Gauding, NF0R  
 Illustrated by: Paul Harden, NA5N



AFTER GLUING, EXPOSE TO A 100 WATT LAMP. WARMED ADHESIVE WILL FLOW THRU COIL WIRE FOR SOLID BOND. CURE FOR 24 HOURS.

**⑥ 24 HOURS LATER...**

REMOVE ALL 2-56 HARDWARE FROM COIL FORM & GROMMETS. PULL OUT WIRE STUBS FROM HOLES "A" AND "C".

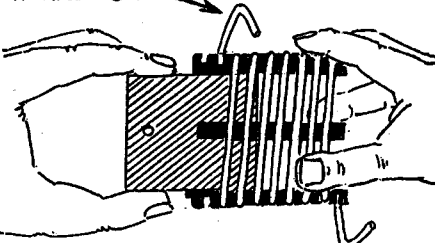

GENTLY SLIDE COIL FROM FORM. BEND WIRE STUBS BACK INTO GROMMET HOLES WHEN DONE.

**⑦ BUILD COIL SUPPORTS (2)**

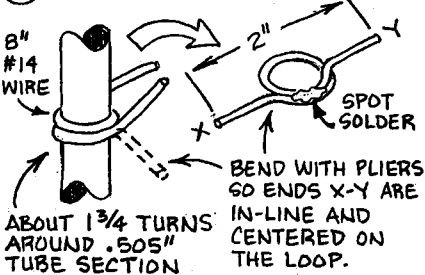

**⑧ CUT 3/32" DIA. BRASS TUBING INTO THREE PIECES 1/2" LONG AND ONE PIECE 3/4" LONG FOR THE COUPLERS.**

1/2"

3/4"

**⑨ ASSEMBLE TOP SUPPORT**

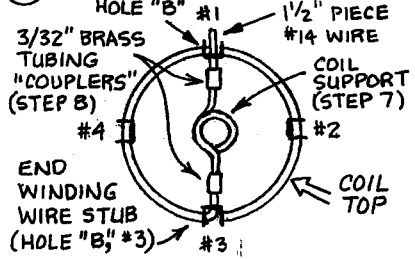

MOUNT TOP COIL SUPPORT TO COIL END WINDING WITH COUPLER, THEN SOLDER. ADD 1/2" WIRE PIECE WITH COUPLER AND SOLDER.

**⑩ BOTTOM SUPPORT**

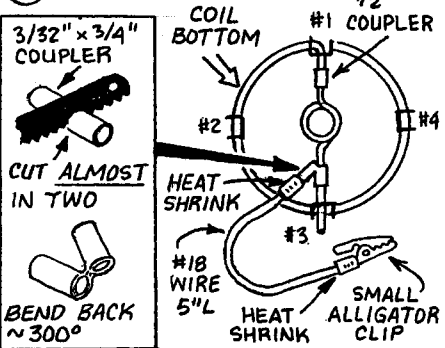

**⑪ FINISHING TOUCHES**

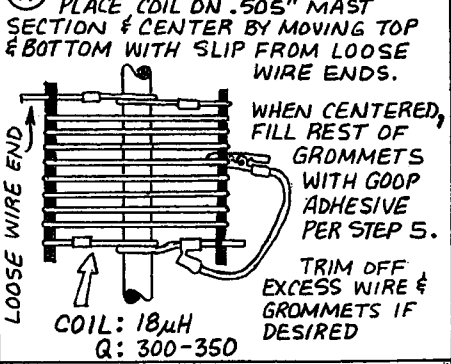

and allow for two shallow turns between the cotter pin and the horizontal support at the top of the coil. Now add two 3/16 heatshrink tubes. Finish these radiators with a small alligator clip crimped and soldered. Heatshrink the connections.

4. The lower radiator is a constant at approximately 6 feet. Allow for two shallow turns along the lower support when measuring. Add two 3/16 heatshrink tubes to the wire. Terminate each end in a small alligator clip as described above. Heatshrink the connections.

#### **SLQ Radiator Construction**

1. The specialized ribbon cable radiator is fed at the bottom through the center conductor only. It is shorted at the top allowing the two outside conductors to function as loading wires. The loaded configuration resonates on 20M with an 11 foot high radiator instead of the typical 16-1/2 foot extension of a full-size quarter-wave vertical.

2. Begin by stripping 1 inch of wire at one end of the three-conductor ribbon cable. Short all conductors by twisting and then loop through the lower eye of a fishing swivel. Solder the connection. Now add one section of 3/16 heatshrink at the top of the ribbon and a 1/8 and 3/16 heatshrink sections at the bottom.

3. Attach the ribbon to the support's tip section. Assemble and install the support. Place two shallow turns along the tubing to control sail area and trim the radia-

tor so it will meet the feedpoint with a small alligator clip attached.

4. At the unfinished end of the ribbon trim the outside conductors back approximately three inches from the end. Now strip 1/2 inch of insulation from center conductor. Twist the strands and insert through the small alligator clip from the inside. Position the wire so the protective tabs will fold over the pvc insulation.

5. Dress the strands on the outside of the clip and solder. Then bend the protective tabs into place. Now heatshrink both soldered connections. After the radiator is tuned use the 1/8 section of heatshrink to streamline the ribbon edges where the outer conductors and inner conductor meet.

#### **Radial Construction**

1. The ground radial system consists of eight St. Louis Radials (SLR) with seven parallel 8-1/2 foot conductors. This places 475 feet of wire under the antenna in a compact 17 foot diameter footprint.

2. For each radial begin by stripping 1 inch of wire from the conductors at one end. This can be done manually but a commercial multi-conductor wire stripper is the preferred alternative. (see Construction Notes). Add one section of 3/16 heatshrink tubing at the stripped end of the ribbon.

3. Twist the stripped ends together. Remove and discard the screw from the medium alligator clip. Insert the prepared wire bundle into the tubular extension and then out through

the punched access hole in the clip. Position so the insulation projects slightly past the inside end of the tubular extension. Now dress the twisted wire along the outside of the clip and solder in place.

4. Using pliers or a vise crimp the tubular extension so the ribbon is held firmly in place. It is not necessary to crush the insulation. Heatshrink the connection.

### **Construction Notes**

The standard SLPV tap assembly serves 2 bays and 37 tapping points. The tap wire may be built longer to reach the all bays in the coil though this is not necessary to achieve a usable match.

Straightening out bumps in the copper or buss wire by hand before winding the coil produces a more attractive sub-assembly and ultimately saves hand labor. Cleaning and burnishing the fully extended wire with a fine steel-wool pad is also helpful. Use a needle-nose pliers for the final alignment of turns in a completed coil. Work from the edge of a grommet towards the center of the turn.

A compact mini hacksaw (Note 6) with a very thin, low-profile 32-TPI blade is recommended for trimming fiberglass stock manually. Alternative cutting methods include a hi-speed cutting disk or a lathe running at slow speed with a well-sharpened cutting tool.

A common handloader's cartridge case de-burring tool is handy for cleaning-up the cut edges of fiberglass tubing in place of a tapered

reamer and emery paper.

The #10 drill can be replaced with a more readily available 13/64 inch drill. A heat-treated drill can substitute for a drill blank in the foot-powered mount.

A heavy-duty 1/8 inch wall (minimum) mailing-tube is mandatory. It insures the form does not collapse under pressure from the coil during winding and subsequently aids with removal. Cut one end of the tube square to insure the grommet's vertical reference lines will be located properly.

Apply a coating of WD-40 or a silicone lubricant to the bottom of the grommets before installing them on the form. This provision is helpful when it is time to remove the wound coil. Do not spray the cardboard directly.

There is room for three different bulkhead antenna jacks on the standard feedpoint assembly. A full array might include BNC, SO-239 and a double-binding post. The latter is suitable for a coaxial feedline without a mating connector or tuned feeders.

Building a St. Louis Radial set is tedious and time-consuming process due to the repetitive stripping of small diameter easily damaged conductors. Access to a commercial multi-conductor wire stripper is the preferred alternative to manual stripping. This hand-held tool can be borrowed at a customer-friendly computer repair shop. The sensible approach is to bring pre-measured ribbons (and a practice

ribbon) to the shop and do the work right on the premises.

3M Scotchflex ribbon cable P/N 3302 (No. 28 AWG) was used for prototype radials and radiators. This type was chosen because rainbow/multi-color pvc insulation can be lighter and more flexible than many gray pvc coated products. However, most flat ribbon cables are suitable for these applications.

5 or 10 minute epoxy allows sufficient working time to assemble several fiberglass parts. Epoxy is generally easier to mix accurately in smaller quantities in order to achieve maximum strength. Builders anticipating rough handling or operating in temperature extremes may wish to install small diameter brass reinforcement pins in the ferrule/tubing joints and mounting base.

The surfaces of the fiberglass tube sections and ferrules must be thoroughly de-greased before epoxy cement is applied. Isopropyl alcohol on a Q-tip works well. Roughen overlapping parts with a coarse file or sandpaper. After construction clean the inside of each ferrule and tube to remove fiberglass shavings and manufacturing residues.

Depending on manufacturer or production lot the fit of fiberglass tube to internal ferrule may not be perfect. Swapping tubes around usually works but not always. Minimum clearance can be improved by using fine emery paper to carefully reduce the diameter of a ferrule.

### **Support and Antenna Installa-**

### **tion**

1. Remove the protective cover/feedpoint extender from the mounting base sub-assembly and re-install on top. Now add the feedpoint disk above. Then slide the horizontal installation rod into position.

2. Install five 12 inch tubing sections on the mounting base. Press this sub-assembly into the ground manually using body weight. Stop when the fiberglass coupler reaches the earth. In hard ground locations this insertion depth may be adequate to support the overhead weight and sail area.

3. For soft ground the horizontal installation rod provides the leverage needed to ease the base mount into final position. Use shoe toes only to apply pressure while keeping the support vertical. Continue to insert the tapered nose-piece until the steel rod rests firmly against the earth.

4. SLVPV Radiator: Attach the upper radiator to the tip section and assemble the remaining tubing. Then slide the coil on to the sixth tube. While holding the coil in place slip this sub-assembly over the ferrule of the fifth tube. Add the tap wire to the coil. Now attach the upper radiator to the coil support at point B. Then attach the lower radiator to the coil support at point D and to the feedpoint. Add the radials and feedline to the feedpoint disk.

5. SLQ Radiator: Attach the loaded ribbon to the tip section then assemble and install the remaining

tubing. Attach the radiator, radials and feedline to the feedpoint disk.

### **SLPV Coil Tuning**

1. The St. Louis Coil can be matched for each band by trial-and-error using a sensitive low-power SWR bridge. A noise bridge or a direct frequency readout device can also be used to resonate the antenna.

2. The table (Note 8) provides coarse tap locations for the standard coil and radiator assemblies. Start with the lowest design frequency and move to the highest.

3. Using 20M as an example begin tuning by attaching the removable tap at point D and shorting out the third turn from the bottom of the coil. When using an SWR bridge apply low power (1-2 watts) and compare the forward and reflected readings.

4. Fine tune if necessary by repositioning the tap along that turn on either side of the grommet. During testing the tap wire may be extended temporarily with a jumper.

5. Expect a 3 to 1 SWR reading or higher at non-resonant points. Reaching a 2 to 1 SWR suggests the resonant point is on an adjacent turn. Typical SWR at resonance is between 1.2 and 1.5 to 1.

6. Users faced with a difficult match should first try adjusting the upper radiator length. Changing the feedline length is another option. On rare occasions when a tapped coil cannot produce an acceptable SWR the antenna can be fine-tuned with a transmatch after coarse tuning with the tap.

7. Apply 5 watts to confirm the accuracy of resonant points determined at low power. Then increase to 50 watts if available. If SWR increases significantly repeat the tuning process until a reliable match is achieved.

8. Using the SLPV at multiple operating sites means changing RF environments. Besides nearby influences the proximity of the feedpoint to the earth and radial positioning become contributing factors. Such complex interactions may call for different tap settings. However, once a coarse tap location is established for a band the final match is generally easy to restore.

### **SLQ Radiator Tuning**

1. The loaded 11 foot ribbon radiator is fine-tuned on 20M by removing wire equally from the two outside conductors to lower the resonant frequency. The amount of wire removed will vary with different types of flat cable as well as individual construction practices.

2. When using an SWR bridge take initial readings at a few watts to determine where the radiator is resonant on 20M after construction. Then remove the loading wires in 1/4 to 1/2 inch increments on both sides to achieve very low SWR (typically 1.5 to 1 or less) at approximately 14.025 kHz. Then apply 5W and finally 50W to confirm the match.

3. The radiator's resonant point is typically very sharp but with a gen-

erous bandwidth. The SLQ can still be tuned remotely with a transmatch for all bands between 10-20M.

### **Portability Features**

The breakdown 14 inch by 2 inch antenna support has no sharp projections and stores safely anywhere. Several wide-body small diameter rubber bands used for produce display are ideal for securing the tubes in place.

All accessories for either antenna will fit in comfortably a round low-profile container (Rubber Maid "Servin Saver" - 1.7 L.) With careful packing there is room left-over for a short RG-174 feedline.

The St. Louis Radials store conveniently in the above container in finger-rolled units of four ribbons. Butt the ends of the cables together after positioning the alligator clips so the finger-tabs face to the outside. For storage elsewhere lay the coiled radials flat on a hard surface and secure with two tie-wraps.

### **Performance Issues**

The lightweight 1-1/4 inch diameter air-wound coil sacrifices a higher "Q" for reduced sail area. Being rigid as well as compact it is better suited to field service than a large diameter coil. The removable tap assembly is a concession to durability as well as convenient storage.

The hardened steel drill blank used in the foot-powered mount and the alligator clips used for the St. Louis Radials should be treated pe-

riodically with a rust preventative such as WD-40.

When installed properly the lightweight support is quite stable in gusting winds. In addition, the stealth characteristics of either design may be advantageous to operators faced with restrictive covenants.

Both antennas were tested extensively on the air at up to 50W output. Either antenna should take higher power but testing was limited by the equipment available.

The test feedline was 45 feet of RG-58 coax and included an 8 foot/six-turn scramble-wound RF choke positioned at the feedpoint. Informal testing was also conducted with RG-174. The SLQ has been operated with tuned feeders including twinlead, speaker cord and WE6W-type ribbon cable feedline.

The SLQ test log was produced with 6 quarter-wave ribbon radials cut for 20M. Folding the 16-1/2 foot radials 90 degrees at the midpoint (to save space) did not have a noticeable impact on performance. The SLVPV test log was completed using 8 eighth-wave ribbon radials cut for 20M. This 8-1/2 foot configuration has evolved into the preferred portable radial system for either antenna. It strikes a useful balance between convenience and performance potential.

The electrical characteristics of the SLQ's loaded ribbon cable radiator remain undefined. A follow-on project involves applying the concept to resonant 30M, 40M and

80M vertical antennas.

Prospective builders can evaluate a test log (minimum 100 contacts) compiled for each antenna. The output from a calibrated source was one watt or less on 20M. E-mail [nf0r@slacc.com](mailto:nf0r@slacc.com) with either "SLQ Test Log" or "SLVPV Test Log" on the subject line.

### Conclusion

Some readers will note text similarities with the recent St. Louis Pocket Vertical & St. Louis Coil projects for 10-40M. The building instructions for several sub-assemblies are repeated here instead of pointing builders to reference material that may not be immediately available.

These are labor-intensive homebrew antenna projects with the tapped air-wound coil the most time-consuming. Since the fiberglass supports are identical builders can get on the air promptly with the ribbon cable radiator and add the coil later.

For convenience the SLVPV is known simply as the "vest pocket vertical". The SLQ is aptly described as the "quickie" since its installation time is five minutes or less. Both antennas and the companion radial system are well-suited for QRP portable including vacationing, hiking, backpacking and more recently lunch-hour operating.

### Text Notes and Tuning Table

1. Fiberglass kite tubing is available from Hang-em-High at <http://www.citystar.com/hang-em-high/cat-2.html> or (804)233-6155. Ref-

erence p/n FGT505 and p/n FGT414. Note that the .414 tubing used for internal ferrules is not carried by all retailers of kite building materials. The drilled solid fiberglass rod used for .411 internal couplers in .505 tubing is p/n IF411.

2. Slotted-wall nylon grommet edging is an OEM product but is available by the piece from some electronics parts distributors and surplus outlets. The SLPV prototypes use Panduit p/n GE192-SS. Current production may also be described as MS21266-4N. See <http://www.panduit.com>. The manufacturer of this semi-rigid material is not critical. However, the slot width should be approximately .067 to work well with #16 (or #14) solid wire. Note that grommet edging is not the same product as caterpillar grommet which is flexible and sold on spools.

3. The medium alligator clip (RS 270-346B), small alligator clip (RS 270-380A) and small smooth-jaw micro alligator clip (RS 270-373B) are stock items at Radio Shack® stores.

4. 3/32 inch diameter brass tubing and a small Excel<sup>®</sup> Hobby Tools #55665 aluminum miter box are available at many full-line hobby shops. See <http://www.phoenix-model.com> for a picture.

5. Goop<sup>®</sup>, a clear non-silicone sealant/adhesive, is available at many major hardware and automotive supply stores. Any variation within the product family is usable. The marine, outdoor and sportsman



types are UV resistant to limit discoloration. Call (800)349-4667 for local retail sources other than Home Depot, Lowes, Wal-Mart, Tru-Value, etc. There is no Twenty-two points, plus triple-word-score, plus fifty points for using all my letters. Game's over. I'm outta here. website for the product at this time.

6. A Zona™ #680 Junior Hack-Saw is carried by Into The Windâ at <http://www.intothewind.com> or (800)541-0314. Reference the nine-inch #4920 saw and #4921 32-TPI saw blades for cutting fiberglass. An imported mini-hacksaw with 32-TPI blade recommended for cutting fiberglass tubing is available from Hang-em-High (Note 1) but has not been tested. Reference p/n SAW and p/n SAWB. These specialized saws can be found in some local hobby, woodworking and craft stores.

7. A 1-1/4 inch diameter cardboard coil form (with 3/8 inch wall) used for one prototype is not a common office supply item. The form came from a center-support for 20 inch spools of industrial plastic wrap used to protect palletized ship-

ments from the weather. The discarded "sticks" from hand-wrapping operations can be had for the asking from dock personnel at small shippers. Builders choosing this heavy-wall coil form can omit internal nuts and washers from the mounting hardware list.

8. Coarse Tap Points for the SLVPV Coil (turns measured from bottom of coil at grommet 1) and Upper Radiator Lengths (approximate):

Band Nr.	Turn	Upper Radiator
20	3 72	
17	14	72
15	1 24	
1	8 24	
10	19	24

**References**

- St. Louis Pocket Vertical (SLPV) & St. Louis Coil (SLC) – QRPp, Spring 2000
- St. Louis Express Vertical (SLX) – QRPp, Summer 1998
- St. Louis Radials (SLR) – QRPp, Fall 1997

**Copyright 2000 by Dave Gauding, NF0R – All Rights Reserved.**

# NorCal Resistor Kits

NorCal Resistor Kits are back!! The popular 1/4 watt resistor kits that we did 4 years ago are now available again. To order a set of 25 resistors each in the following values (2000 Resistors Total):

1, 2.2, 2.7, 3.3, 3.9, 4.7, 5.6, 6.8, 8.2, 10

12, 15, 18, 22, 27, 33, 39, 47, 56, 68, 82, 100

120, 150, 180, 220, 270, 330, 390, 470, 560, 680, 820, 1K

1.2K, 1.5K, 1.8K, 2.2K, 2.7K, 3.3K, 3.9K, 4.7K, 5.6K, 6.8K, 8.2K, 10K  
(50 of this popular value)

12K, 15K, 18K, 22K, 27K, 33K, 39K, 47K, 56K, 68K, 82K, 100K

120K, 150K, 180K, 220K, 270K, 330K, 390K, 470K, 560K, 680K, 820K,  
1M

2.2M, 2.7M, 3.3M, 3.9M, 4.7M, 5.6M, 6.8M, 8.2M, 10M

Send a check or money order for \$25 made out to Jim Cates to:

Jim Cates  
Attn: Resistor Kit  
3241 Eastwood Rd.  
Sacramento, CA 95821

Please enclose a self-addressed mailing label. DX orders please add \$5 for shipping and handling. Only 200 sets available. Please email Jim at [wa6ger@juno.com](mailto:wa6ger@juno.com) to check on availability before sending order.

# The NorCal Web Page

NorCal maintains a web page that has many late breaking announcements of interest to QRPers. Our web master is Jerry Parker, WA6OWR. Please check the web page at:

[www.norcalqrp.com](http://www.norcalqrp.com)

## Subscription problems?

Paul Maciel, AK1P maintains the NorCal Database. If you have a question concerning your subscription please contact Paul at: [ak1p@earthlink.net](mailto:ak1p@earthlink.net) or by mail at:

PAUL A MACIEL  
1749 HUDSON DR  
SAN JOSE CA 95124

## QRPP Subscriptions

QRPP is printed 4 times per year with Spring, Summer, Fall and Winter issues. The cost of subscriptions is as follows:

US and Canadian addresses: \$15 per year, issues sent first class mail. All DX subscriptions are \$20 per year, issues sent via air mail. To subscribe send your check or money order made out to Jim Cates, Not NorCal to:

Jim Cates  
3241 Eastwood Rd.  
Sacramento, CA 95821

US Funds only. Subscriptions will start with the first available issue and will not be taken for more than 2 years at a time. Membership in NorCal is free. The subscription fee is only for the journal QRPP. Note that all articles in QRPP are copyrighted and may not be reprinted in any form without permission of the author. Permission is granted for non-profit club publications of a non commercial nature to reprint articles as long as the author and QRPP are given proper credit. Journals that accept paid advertising, including club journals, must get prior permission from KI6DS before reprinting any article or part of an article. The articles have not been tested and no guarantee of success is implied. If you build circuits from QRPP, you should use safe practices and know that you assume all risks.

**QRPP, Journal of the NorCal QRP Club  
862 Frank Ave.  
Dos Palos, CA 93620**

**First Class Mail  
U.S. Postage**

**Paid**

**Mailed from Zip Code**

**93620**

**Permit #72**

**First Class Mail**