



SPRAT

THE JOURNAL OF THE G-QRP CLUB

DEVOTED TO LOW-POWER COMMUNICATION

ISSUE NR. 59

© G-QRP CLUB

SUMMER 1989

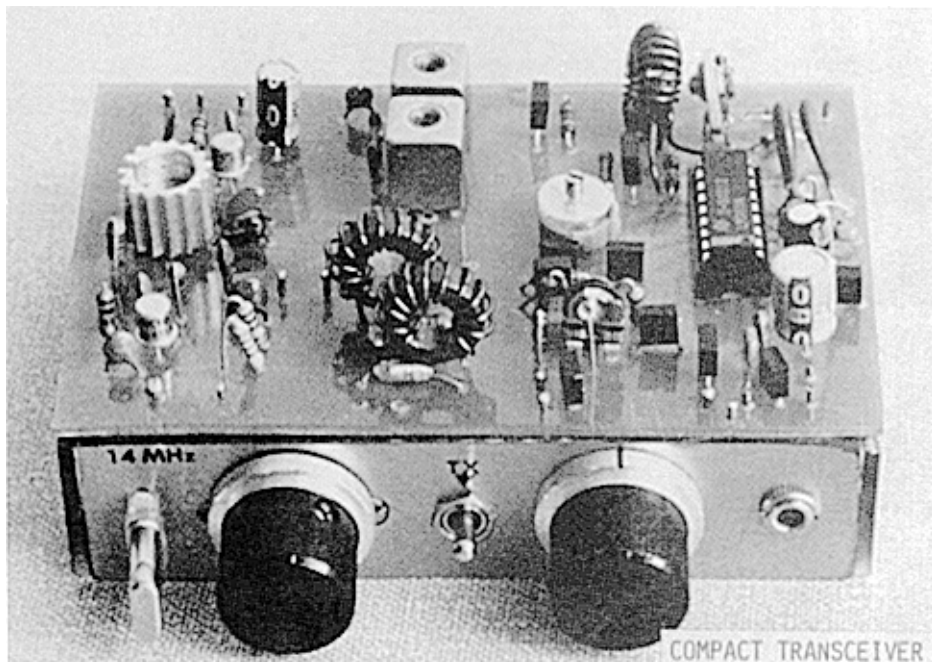

THE COMPACT TRANSCEIVER * G3BGR LOOP * TWO TONE OSCILLATOR
SURFACE MOUNTING * THRESHOLD GATE LIMITER * CLASSIC A.T.U.
QSK MIXER/PA * UPGRADING THE HW7 * BROADBAND AMPLIFIER
TRANSVERTER ATTENUATION * HW9 MODIFICATIONS * PCB IDEA
ARGONAUT ON QRO * NEWS OF THREE QRP EVENTS * PCB OFFER
COMMUNICATIONS FORUM * SSB NEWS * MEMBERS NEWS

JOURNAL OF THE G QRP CLUB

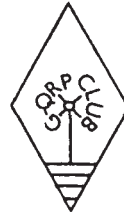

© G-QRP CLUB

*St. Aidan's Vicarage,
498 Manchester Rd
ROCHDALE,
Lancs,
OL11 3HE.
Rochdale [0706] 31812*

Rev. George Dobbs G3RJV

Dear Member,

First of all, take your last issue of SPRAT, and a pen. Look on the front cover and where it says "AUTUMN 1989", strike out "autumn" and write in "SPRING". You might get mixed up in future years.... like I did last issue!

Thank you to the member who sent extra donations for the QRP Day for the Willis Church Organ, we did take the total to over £1,000. Many thanks.

Future Items in SPRAT : The LCK Superhet Receiver/Transceiver has been held over until next issue (autumn) and the White Rose multiband receiver will appear in the winter issue. Both will have PCBs or full kits. We have also had a rather surprising number of Loop Antennas offered by members and these will appear in forthcoming issues, beginning with the G3BGR Loop in this issue. These compact HF Antennas should create quite a lot of interest for restricted space or portable operation.

As the club links with the USSR increase, may I draw your attention to a new club : The CLUB OF FRIENDSHIP BETWEEN RADIO AMATEURS OF THE USSR AND UK. The UK co-ordinator is Mr. K.F. Norvall, G3IFN, 24 Ryedene, Vange, Basildon, SS16 4SY, who can supply further information for a stamped envelope.

This issue was prepared slightly early, just before G3R00 and left for the ARRL National Convention in Dallas, no doubt we will have a full report on that event in the next issue of SPRAT.

I hope to see many of you at the Mini-Convention in Rochdale.

73 fer nw....

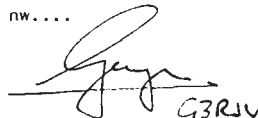
G3RJV

THE ARGONAUT II, QRP AT IT'S FINEST . . .

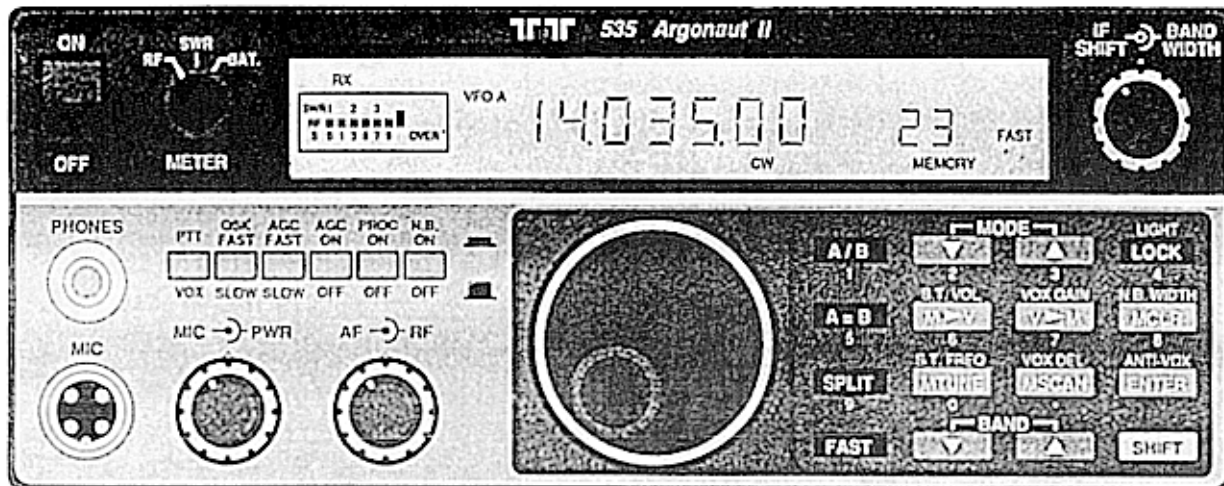

SHOWN ACTUAL SIZE

The all new Argonaut II is the latest in a long, proud line of QRP rigs from Ten-Tec. This is a completely synthesized, PLL design which includes a general coverage receiver from 100 kHz to 29.999 MHz. The transmitter operates all ham bands, from 160 through 10 meters, SSB, CW and optional FM.

The maximum power output is 5 watts and is adjustable down to a few milli-watts. The rig is designed for energy efficiency for practical battery operation and features a large, multi-function, LCD display with selectable back lighting. Dual VFOs, non-volatile RAM memories and all of the other neat features you have come to expect in a computer based design.

A new Ten-Tec crystal filter (patent applied for) features continuously variable band-width from 500 Hz to 2.5 kHz. This allows the I-F band-width to be set exactly for the mode in use and the band conditions. This, in combination with the I-F shift adjustment, delivers outstanding receiver performance.

Another innovation, seen for the first time on the Argonaut II, is our "soft control" system (patent applied for) that allows front panel adjustment of VOX and sidetone controls. This is accomplished using shifted functions of the existing control buttons so no clutter is added.

We designed the Argonaut II for the QRP purist. When you say "rig is Argo 2" you are QRP without question.

COMPLETE SPECIFICATIONS WILL BE PUBLISHED JUNE 1989. TARGET PRICE \$90. AVAILABLE OCTOBER TIME FRAME.

NEWS FROM TEN TEC

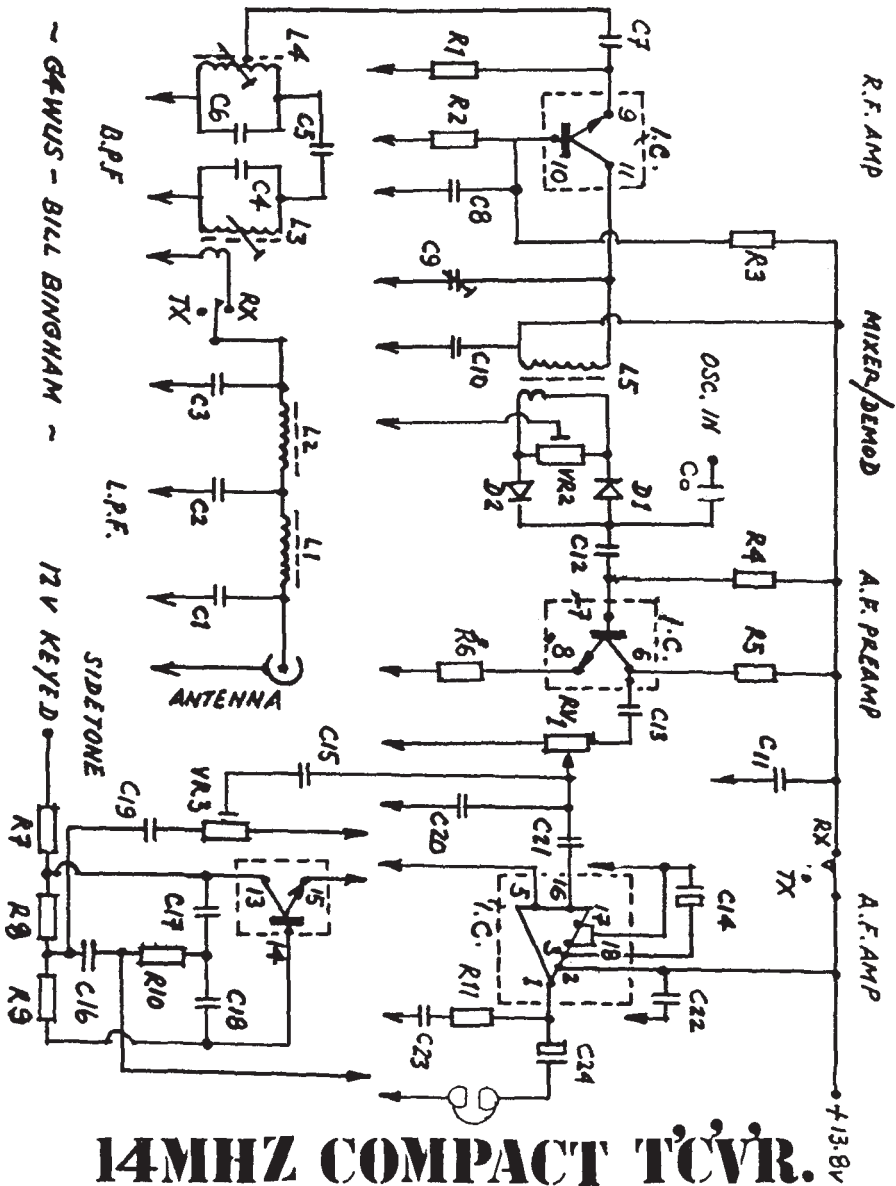

14MHZ COMPACT TCVR.

PARTS LIST

Semiconductors

D1, D2	IN 4148 matched pair
IC1	LM389N
TR1	BC107
TR2	2N4427
TR3	BCY70

Capacitors Polystyrene

10pF	C5
100pF	C4, C6, C25, C27
220pF	C1, C3
360pF	C2
	Ceramic Plate
10nF	C7, C8, C15-C21, C26-C30
	Polyester
10nF	C23
0.1uF	C10-C13, C22, C32, C33
	Electrolytic, 25v p.c. mounting
10uF	C14
47uF	C31
100uF	C24
100pF Trimmer	C9
100pF Variable	VC1

Inductors

L1, L2	12 Turns 22 swg on T-50-2
L3*	14 Turns 26 swg, Link winding 4 Turns
L4*	14 Turns 26 swg, tapped at 10 turns L3/4 on 4.8mm former + core
L5	20 Turns 22swg on T-50-2, 2 turn link over cold end
L6	10 turns 32 swg on ferrite bead.

NOTE: L3 and L4 on the PCB are Toko 3335 coils with C4/6 = 100p and C5 = 3p
XC1 14.060 fundamental

Resistors 1/4w 5% carbon film

2R2	R11
39R	R17 adjustable
100R	R14
150R	R6 adjust for gain (or short)
1K	R12, R15, R16
2K7	R1
4K7	R10
10K	R5, R7
18K	R2, R8, R9
33K	R13
100K	R3
5M6	R4
VR1	22K Lin.
VR2	1K Preset
VR3	4K7 "

Miscellaneous

Phone sockets
3.5mm Jack plug sockets
Switch SPCO (on/off)
Switch DPCO (12VRX/TX & Ant Changeover)
PCB 110mm x 75 mm

NOTE: Co, 0.1, or less (adjust on test)
is mounted under the PCB as shown.

G4WUS "COMPACT"

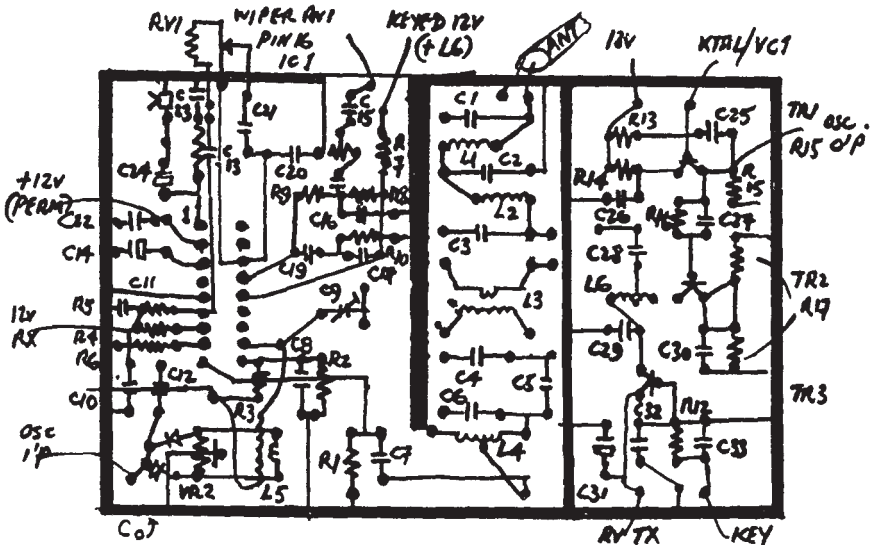

COMPONENT LAYOUT

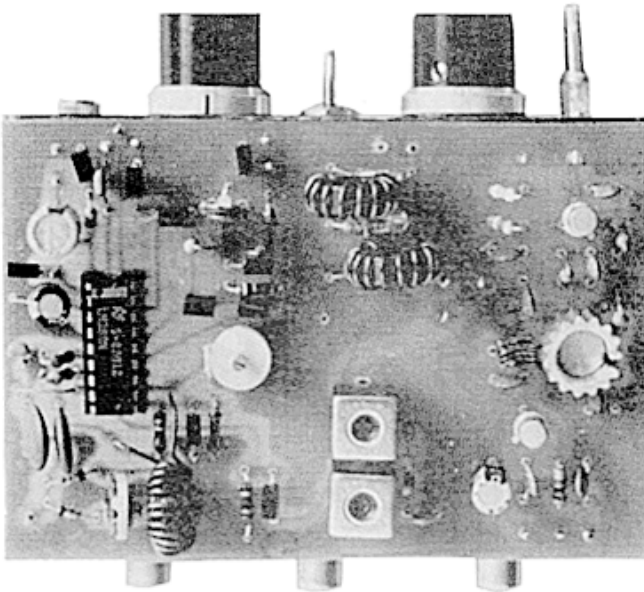
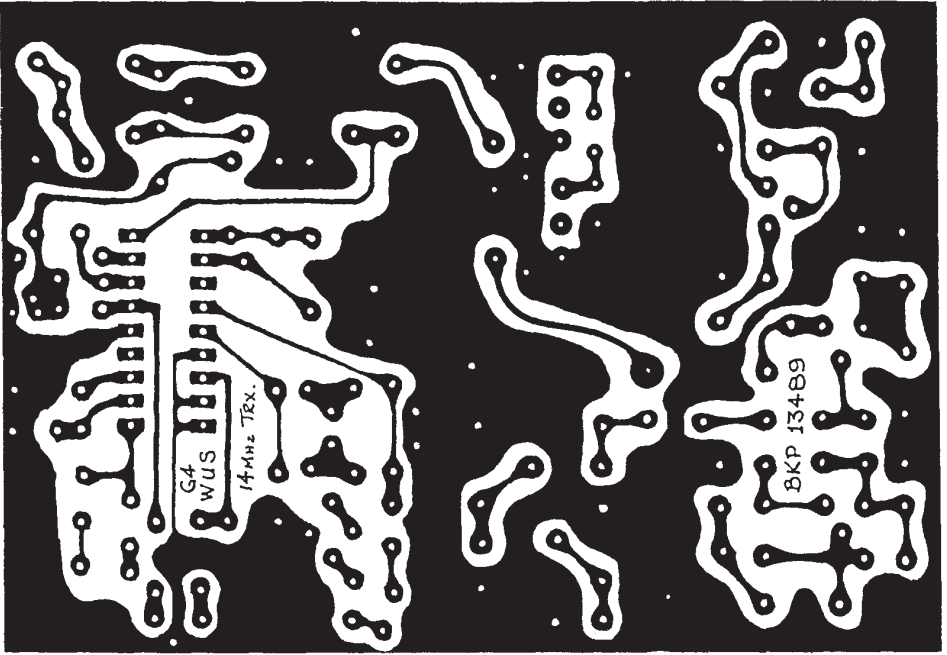

PRINTED CIRCUIT BOARDS FOR "THE COMPACT" ARE AVAILABLE AT £2.00 (20p Postage)
from: Dave Aizlewood, G4WZV, 36 King St. Winterton, Scunthorpe, DN15 9TP.
Please make out cheques to "G QRP CLUB"

COMPACT 14 MHz TRANSCEIVER
 Bill Bingham G4WUS

The rig came about when I saw the LM389N IC in a radio that I was trying to mend. It looked quite a useful device so some were purchased from Farnell (or Maplin - under £2.00).

As you can see from the circuit diagram there are 3 VHF transistors and one audio amp all in this chip. One transistor was to be used as a RF amp, one as a audio pre-amp and one as a sidetone oscillator. All the filters were included because the RF amp, being bi-polar, is more prone to break-through, so I decided to give it as best a chance possible.

The audio amp side was a bit tricky at first and was finally cured by decoupling capacitors, it could perhaps be improved further.

The TX is an 'OXO' which is already documented in SPRAT and GQRP handbook.

Sidetone and RX bandpass filters circuits came from the PW TEME.

Antenna and 12v RX/TX change over is by DPCO switch.

I am fortunate to have a Marconi Radiotelephone test set (TF2952) and with this I could still hear RF at 0.5uV and the output power of my rig was 600mW.

My first QSO was with a UC2 who rubber stamped me, my second was a 2XQRP QSO with IT9 (with QRM from ZS and W - HI!)

I hope it works OK!

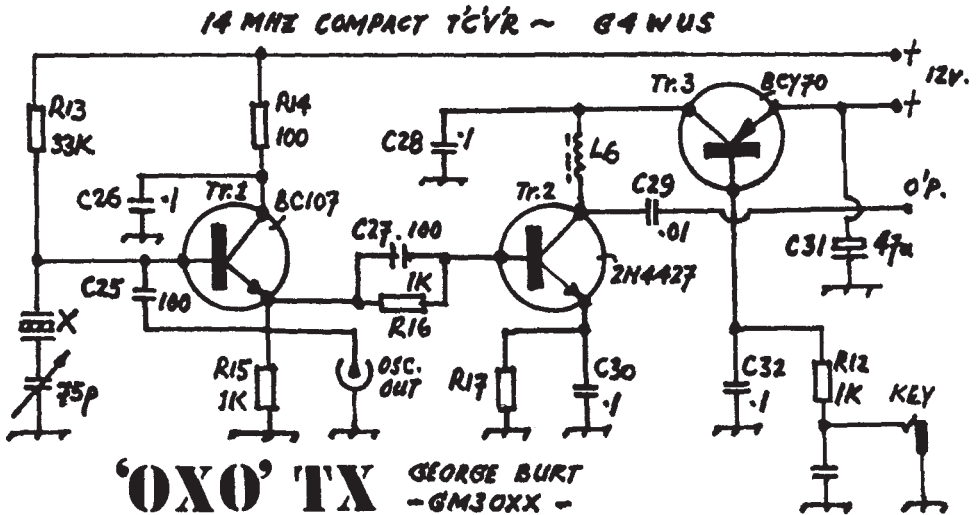

EUCW NEWS....

It is with sadness that we report the death of Eduard Schnell, DL6MK. Ed was the Chairman of EUCW before Tony, G4FAI, and also President of the High Speed Club of Germany and organised the World High Speed Telegraphy Championships to be held in Hanover in November. Ed made a large and valuable contribution to international morse telegraphy and was very active on the 3.5MHz band. Angie, GØHGA, the G QRP ECM for EUCW has sent condolences on behalf of the club.

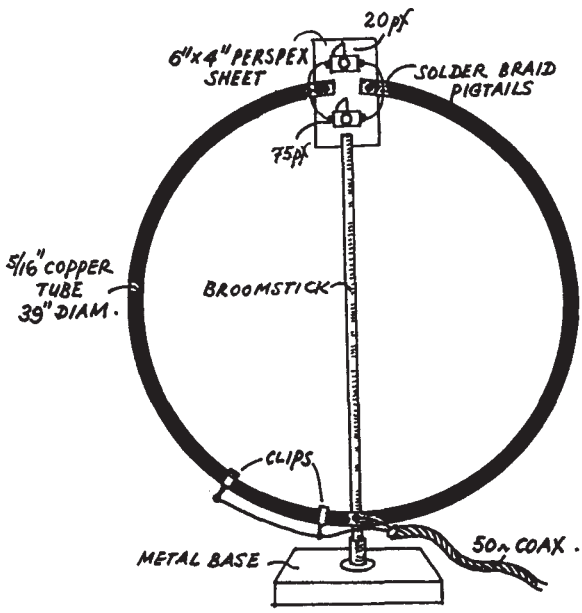

THE G3BGR LOOP

S. D. PERCIVAL
G. QRP. C-013

This is a home brew Magnetic loop ant I have been using indoors on 7,10 and 14 Mhz. The basic idea is from 'Radcom' '86. System (g).

A 10' length of 5/16th copper tube gives a 39" loop. An old metal chassis for base, piece of broom handle for upright, and a 4" by 6" perspex sheet fitted into top, to which terminates the end of loop and two tuning condensers mounted 75pf with a 20pf in parallel as fine tuning.

Gamma match is 12" of 1/8th wire spaced 1" from loop.

No atu is used and zero reflected on the three bands loop tunes.

No earth is used other than the normal rig earth. Tests so far have been with main rig ARGOSY II. As loop is such a high 'Q' think it will be fine for output tuning of the 'ONER'. QSO's have been with 5w SSB and 3w CW.

Best DX on 14 USA otherwise all Europe worked, including three G Club Members.

***** QRP BESIDE THE SEASIDE *****

The 1989 QRP Beside the Seaside is again being organised by David, G3OEP. It will be held on Saturday 14th October at the Burrage Centre, The James Paget Hospital, Lowestoft Road Gorleston on Sea, Great Yarmouth from 2.30 to 5.30pm. The Burrage Centre is very comfortable and the meeting will be held in a private part of the bar, which will be open. Simple snacks will also be available.

At the conclusion of the meeting a limited number of people (about six) will be able to visit the Medical Museum of the James Paget Hospital, (David is the Curator), where there is a small collection of Victorian medical electrical equipment and a display of electronic dea aids from 1935 all in working condition. Anyone staying overnight can be taken on a tour of the harbour, which was once the herring port of the world, on the Sunday morning.

Please let David know you intend going. He can be reached on 0493 662323 or by post to 3 Addison Road, Gorleston, Great Yarmouth, Norfolk, NR31 0PA.

STOP PRESS ON QRP BESIDE THE SEASIDE.....

Talk-in will be available on S22 from 1400 from G3OEP/M. The Guest Speaker will be Graham Barrell, G3TKQ, Engineer in charge of Tacolneston TV Station and Postwick and Orford MW Relay Station. An antenna will be available for testing HF equipment and a Mini Flea Market will be open. Prizes available for the Best Homebrew Project and for the person travelling the longest distance.

TWO TONE OSCILLATOR
Ian G3R00

It was very strange to see a similar article appear in Practical Wireless as we were working on similar lines. This design is a much simplified version of the PW one which we hope you will have lots of fun with it.

The problem with any two tone oscillator is that we want as pure a sinewave as possible so that any tests are not distorted by poor test gear, but at the same time we must bear in mind that the resulting measurements in the amateur shack and, on the whole, are done by "eye". This means that there can be a distinct trade-off between complexity and economy... Many other features could be included such as metered output, switched attenuator etc. However, in the majority of cases these would not be wanted and so would only serve to push up the cost.

Other oscillators were tried including the R53 thermistor, but even with this expensive device the distortion was visible to an even greater degree than with the diode system used in this design! The most important factor in obtaining purity is the time taken to set the two tone oscillator up. It is essential that adequate time is left between finishing the soldering for all residual heat to dissipate. When this has happened the overall thermal drift will be negligible and can be ignored. Failure to do this will result in one or both of the oscillators stopping after a few hours. Ideally the unit should be set up using a scope and the output level of each oscillator adjusted using the feedback pot across the diodes so the level is ten percent lower than the peak output.

The circuit consists of two Wein Bridge oscillators fed into a mixer circuit. Each oscillator can be selected independently, this makes the unit more versatile as it can be used for a variety of tests. The two oscillators run on about 1 and 1.5 KHz, but this can be changed by the constructor for his own use.

The output frequency is given by the formula

$$\frac{1}{2 * \pi * R * C}$$

Where "R" and "C" are the components marked on the circuit diagram, for clarity only one oscillator circuit is marked this way.

NB....

This circuit, like several others produced by Ian G3R00 are marketed by KANGA. It is of course copyright! However it is kindly reproduced here with the permission of Kanga on the strict understanding that it is reproduced for your personal use only.

A kit of parts, with full instructions is available from Kanga for £16 (see back page)

A note received from Kanga Products...

Would you please bring to the attention of your readers that there have been copies of some of the ONER PCB's available that have not been produced by us. They are easily recognisable as they are almost double the correct size and some components will not fit the board. The correct boards are of course as their name indicates of one square inch area!

All circuits designed by us are of course copyright and may not be reproduced without permission.

KANGA PRODUCTS TWO TONE OSCILLATOR

1.0 KHz & 1.5 KHz

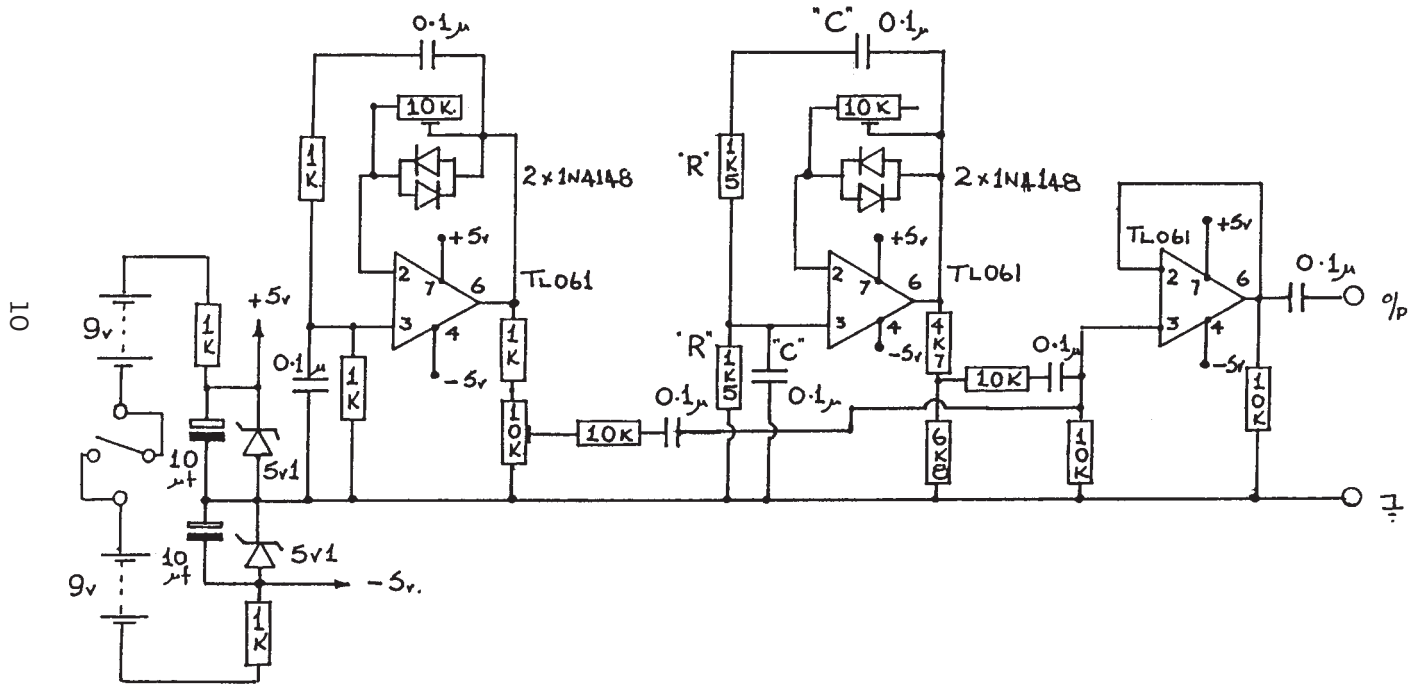

SMT — SMD — GRP

What is SMT and how can we GRPers make use of it?

Bill Mooney G3VZU

The professionals are using Surface Mount Technology at an increasing rate and now most households will have a piece of gear which uses Surface Mount Devices in its innards. The small amateur FM Hand held transceivers for 2m and 70cm would not exist without SMT. Surface Mount technology will certainly be the circuit fabrication technique of the future and it's time we amateurs took advantage of it. Advantage is the correct word here for the benefits are many.

Basically SMT refers to the whole process involving Automatic Pick And Place Machines, Re-Flow Soldering ovens etc. but we need not concern ourselves with this. SMD's are the actual components used and we should concern ourselves with these. An SMD is a leadless component in "chip" form with solder contacts at each end or several leadless contacts in the case of transistors and IC's. SMD's are very small indeed when compared to normal leaded components, but by no means too small to handle. For "By Hand" working the "1206" size components are very convenient. 1206 Chip resistors measure 1.06mm by 0.6mm and dissipate 1/8 Watt. Capacitors of 220nF and lower usually come in this size also. Similarly Transistors and IC's are tiny so you can make some pretty small gear if you want, making use of the very low profile PCB's which can be closely stacked.

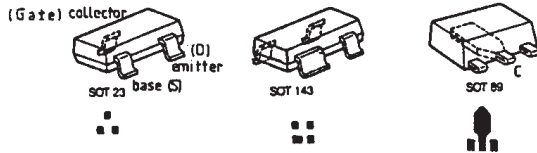

Fig. 1. The most popular SMD Transistor outlines and actual size "footprints"

The main advantage with SMD's is the fact that it is much easier and quicker to produce a good quality finished circuit board than it is with leaded components and what's more it's state of the art. With an SMD circuit there is no need to drill holes because the components and tracks are on the same side of the board. Further it is a simple matter to follow the circuit without having to turn the board over to see where the tracks are going. To make a PCB you just follow the schematic "sense" laying out the components more or less as in the schematic and follow normal drafting and etching techniques.

SMD fabrication is very much in keeping with the concept of GRP being ideal for making small portable equipment, ideal for simple projects, ideal for "dining table" work - needing little support equipment. Because of the lack of leads and low inductance, RF circuits are more efficient and stable and circuits like the VHF pre-amp shown in Fig. 2. have a better and more predictable performance.

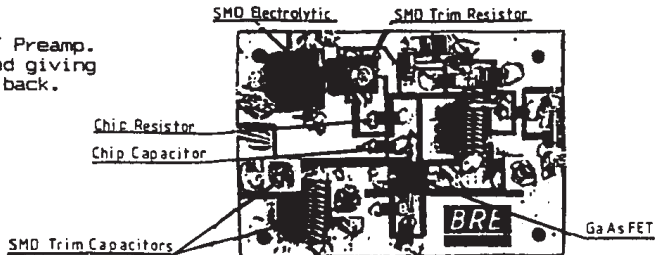

Fig. 2. A GaAs FET VHF Preamp. The PCB is double sided giving a ground plane on the back.

Finished circuits should be protected with a coating of Electrolube Clear Lacquer which can be soldered through if circuit mods or repairs are required. There is no need for amateurs to use adhesives to hold the chips in place.

Practically all your circuits can be fabricated in Surface Mount even GRP PA stages. A good range of components is now available and prices are very reasonable.

A pocket BFO/CIO using Surface Mount Devices (SMD's)

By far the best way to learn about SMD construction is by hands-on experience. The following practice circuit will give you a chance to develop your own techniques for handling SMD's and will give you a useful little Pocket BFO circuit which will tune from about 460 to 470 KHz with a 30pF Trimmer. The BFO is handy for those Short Wave Broadcast sets which cover 7 & 14MHz - you know the one you find when you visit the in-laws and you'd rather be at home in the shack. These SW sets pick up CW and SSB OK but you can't read it without a CIO. A foot of wire from the BFO thrown over the set will do the job. All the bits and a PCB are available from BRE (See Ad.). The Hardware is shown in Fig. 4 and it's an easy matter to see where everything goes, just follow the schematic shown in Fig. 3. The circuit will work on any supply Voltage from 4.5V to 15V.

Fig. 3. A pocket BFO to be made entirely from Surface Mount Components.

Components:

TC, 6.5 to 30pF SMD Trimmer Cap.
 C1, 68pF Ceramic Chip (1206)
 C2, C6, 100pF Ceramic Chip (1206)
 C3, 470pF Ceramic Chip (1206)
 C4, C5, 2n2 Ceramic Chip (1206)
 C7, 1u5/16V Tantalum Chip
 R1, 100k Chip Resistor (1206)
 R2, R3, 1k Chip Resistors (1206)
 TR1, 2N4858 JFET (SOT23)
 L1, 220uH SMD Chip inductor.

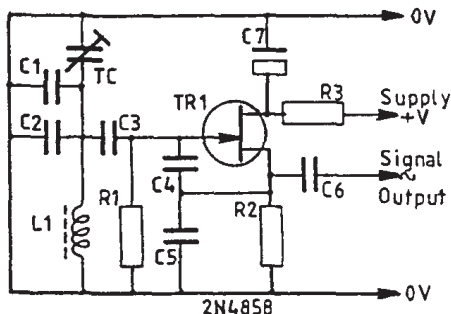

If you try to solder one end of an SMD Chip resistor or capacitor without holding it in place the surface tension of the solder will cause it to stand on end - an effect known as "Tombstoning" by SMDers. So what you do is hold it down on the board with a toothpick and just solder one end. Do this to all the SMD chips and then you can zap around later and solder the remaining ends without the need to hold the SMD's in place. Use a 1/16 th. inch soldering bit for example the Antex one along with the finest solder you can get. Apply the solder and the iron to the job at the same time in the usual way and use the minimum amount of solder. If you get too much solder on then remove it with a solder wick not a solder sucker; the SMD's don't like too much shock, But don't be afraid of them, they are quite tough. If you need to remove a component just move the iron from one end to the other rapidly until both ends melt and then push it out of the way. an easier way is to snap the component in two with a side cutters and remove each half separately. Of course there are rework tools available which make SMD removal very easy.

Resistors are marked with a simple three digit code where the third digit is the number of zeros for example 152 would be 1.5k. Ceramic chip capacitors are another matter, they are not marked so don't unwrap them until you need them because they are easily mixed up. Of course the larger electrolytic Caps are marked with a line at the +ve end and the value in uF and Working Voltage. When all's done with the ckt. apply some Voltage and monitor the current by potential across R3 for example which should be about 2V. The FET suggested is my favourite shure fire device, try a cheaper one.

Fig. 4. A suitable PCB for the pocket BFO and a finished board. No attempt was made to miniatureise but note the low profile of the finished PCB.

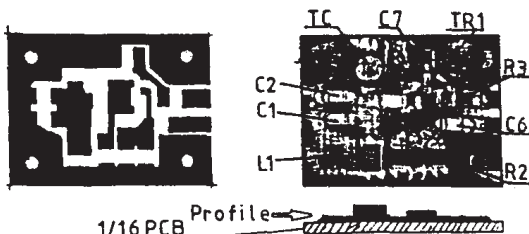

STOP PRESS NEWS FROM U QRP CLUB...

QRP EXPEDITION TO THE EU/ASIAN BORDER : JULY 22nd to AUGUST 1st 1989
 STATIONS: EK3QRP, UZ9CWY/A/QRP, UW9CX/A/QRP and UA9CMR/A/QRP ALL BANDS, ALL MODES.
 WORKING ON INT. QRP FREQS. AMATEURS WHO WORK EXPEDITION CAN RECEIVE A SET OF PHOTOS
 OF EXPEDITION FOR: QSL, SAE+ 10 IRCs from U QRP CLUB, 398043, LIPETSK, P.BOX 229.



BLUE ROSE ELECTRONICS

A full range of SURFACE MOUNT DEVICES for Amateur and Prototyping use.

Surface Mount Technology makes circuit fabrication easier and quicker and is "the" construction technique of the '90's. SMT is particularly suitable for GRP work.

1206 Chip Resistors E12 (E24), ...£0.05 each. SMD min. Trim Res. 1, 5, 10, 50, 100, 500k, 1M...£0.75 each. 1206 Ceramic Chip Capacitor 50V Wkg. 10, 15, 22, 33, 47, 68, 100, 220, 470pF, 1nF, 10, 22, 100nF...£0.10 each. Trim Caps; 6,10,20,30,50pF...£1.30 each



SMD Aluminium Elec. 1uF/50V, 4.7uF/16V, 10uF/16V, ...£0.57. 22uF/16V...£0.77 each. 47uF/16V, 100uF/6.3V, 220uF/4V...£0.87. Tantalum Elec. (Much smaller) 1uF/16V, 4.7uF/16V, ...£0.60. 10uF/16V ...£0.98 each. 22uF/16V, 47uF/16V, 100uF/4V. £1.50.



Chip Inductors; .01uH to 1mH...£0.40 each.

SEMICONDUCTORS; 2N4858 (BSR58) (Hi. Spec. 2N3819) ..£0.75, ZTX300 (BCW32) NPN/Gen. Purp...£0.12, BFR30...£0.50, 2N2222 (BSR14)...£0.30, BSX20 (BSV52)...£0.20, BC108 (BCW32)...£0.14. 1N4004...£0.20, BAT17 Schottky diodes/1pF/4V...£0.20, Zener -5.1, 6.8, 9.1, 12, ...£0.20. CMOS 4001,4011,4069...30p 4029...50p Dual 741 type...50p CMOS 555 timer...£1.20

SMD low mpt. Solder 26SAG...50p per 5m. BFO kit...£3.61, 0.5Watt AF Amp. starter Kit, makes very useful RX OP stage...£6.50. More kits to be released soon. Assembly Jig to hold SMDs in place whilst soldering, indispensable...£14.95 in Kit, £16.50 Assembled.

FULL SMD CATALOGUE...SEND 50P TO COVER POSTAGE ETC. MAIL ORDER ADDRESS: 538 LIVERPOOL RD., GREAT SANKEY, WARRINGTON, CHESHIRE, WA5 3LU. TELEPHONE: 0925 72 7848 EVENINGS. (CALLERS BY APPOINTMENT).

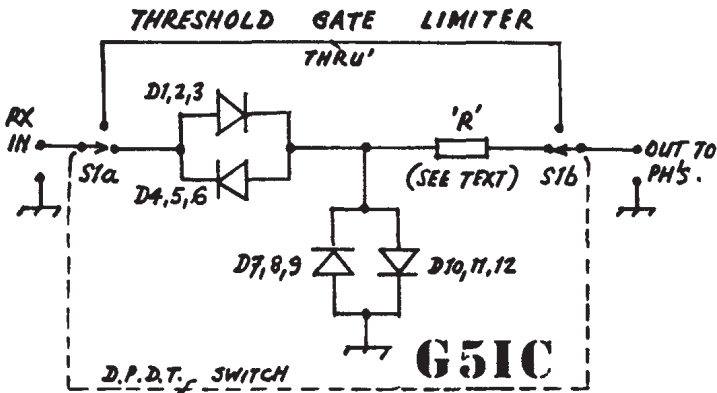

THE G5IC THRESHOLD GATE NOISE LIMITER
G Taylor G8PG

This circuit was originally described in SPRAT 11. I have recently tried it and found it to be very effective. In my version D1-D6 are 0A91s, but any small signal germanium diode will work. Similarly any small signal silicon diode will function as D7-D12; I used 1N4148s. For 8 ohm phones R should be around 80 ohms. For my own 80 ohm phones I made R 180 ohms; it is not critical. S1 allows the limiter to be switched in or out. Results on weak signals in particular are very good. I estimate a 50% improvement in readability, much of it due to the removal of rx hash with the af gain turned up. Background noise on strong signals is also much reduced. Because of the slight squaring action T9 signals have a slight but pleasant "organ pipe" sound. This reduces operator fatigue compared with a pure tone. Verdict; well worth the trouble!

Classic Antenna Tuner

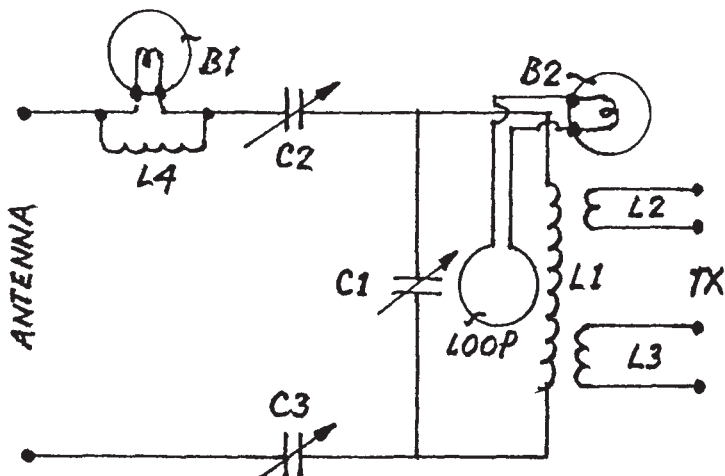

C.F. Rockey W9SCH

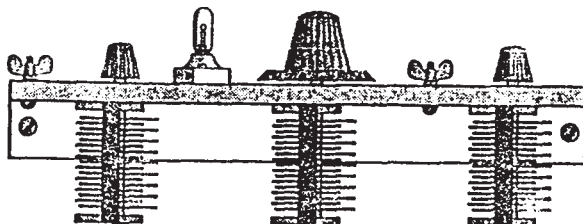

Today we have Classic Coca-Cola, Classic Ovaltine and older automobiles are often refurbished as "classics." So why not a "classic antenna tuner", one which is based on good, old tried and true principles? The diagram in FIGURE ONE is a tuner that has been used at W9SCH for some time. FIGURE TWO shows it from a slightly different perspective. The parts layout is up to you but it remains vital to keep the frames of the capacitors well-insulated and to use an amply-sized and efficient coil if good results are to be had. I have yet to find an antenna at W9SCH that this device will not tune. In February I even tuned up the "hide-a-bed" springs on the shack. Between that time and this writing in March I have worked 20 states with the "hide-a-bed" using it on 80-40-20M CW with 5 watts out! This "Classic Tuner" is a versatile and brutally practical antenna tuner network. It has great flexibility and tuning range. Lots of tuners are all ok for antennas which are nearly in resonance to begin with. But this one will tune and match impedances over a much wider frequency and impedance range than most. It should tune almost anything that an amateur is likely to use for an antenna.

THE PARTS C1, C2 and C3 are 350-365 pF (max. cap.), those from an old BC rcvr are usable. L1 for 3.5 to 10.0MHz is 7mH. 10 turns of close-wound housewiring wire on a 3" form. L1 for 14 to 29MHz is 1.3mH, 3 turns of housewiring wire spaced to occupy 1" on a 3" form. I wound the L1's on 3" diameter PVC pipe. L2 is 1 turn of bellwire around the center turn of L1 and L3 is 3 turns of bellwire around the center turn of L1 L4 is a tuning lamp shunt, 10 turns of bellwire with 1/4" ID. B1 and B2 are pilot bulbs (2V, 60ma). In use, choose the primary winding (L2 or L3) that offers the best impedance match and ignore the unused winding. These secondary coils (the L1's) meet my needs. Should your situation be drastically different, secondary coils of different values may be required.

The use of the 3 variable capacitors provides the wide range without the use of tapped coils or expensive "roller coils." The use of tuning lamps is preferred to dependence on low SWR between xmtr and tuner. When the system is tuned for maximum glow in the little bulb you may be sure that "the soup is up the stack." B2 is connected to an induction loop and inserted into the coil. Use B1 or B2 or both.

Antenna tuning is an art which must be mastered through experience. Here are a couple suggestions. If you believe that your antenna feed point is relatively high, set the two series capacitors (C2 and C3) at maximum capacitance and find resonance using the parallel cap (C1). The induction loop and B2 will perhaps give the best indication of resonance. But if you believe that your antenna has a relatively low feed point impedance, try setting the parallel cap (C1) at minimum capacitance. Then reach resonance by tuning the series caps (C2 and C3) simultaneously. In this case B1 will probably be the best indicator. In most instances, though, the tuning process may not be so simple an direct manipulation of all three caps will often be involved.

In any case, proper adjustment exists when maximum RF current flows within the system (brightest bulb glow), concurrent with the lowest SWR in the xmtr output cable, at the desired xmtr output power. So far, I have always been able to reduce the xmtr-cable SWR to less than 3, which is workable. It is generally agreed that an SWR value of 2 or less is adequate rather than vainly struggle for unity.

(FROM "FIVE WATTER" MI QRP Club)

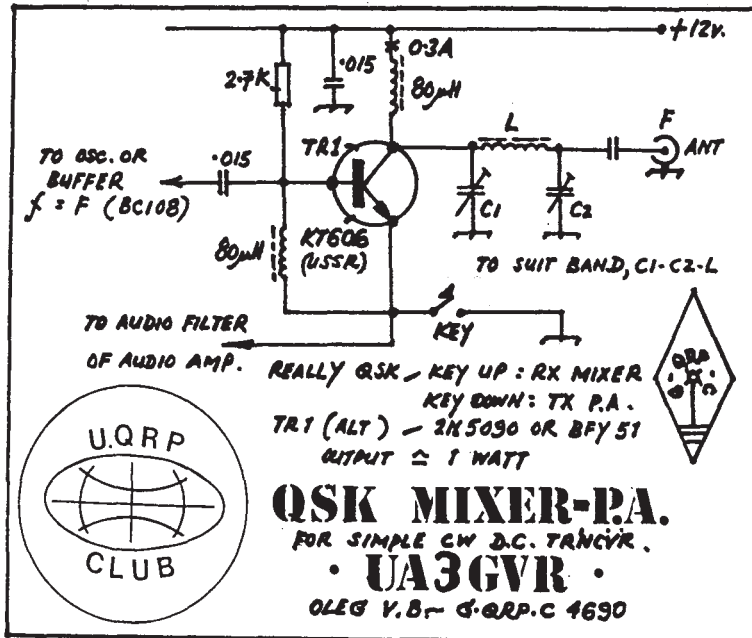

A NICE SIMPLE CIRCUIT IDEA FROM OLEG OF THE U QRP CLUB

DEFINITIVE HW7 MODIFICATIONS BY JACK GLENNON G4ZQK

Who said don't buy an HW7 at any price. They are a cheap secondhand buy and with these modifications make a more than usable transceiver. Adding the input filters eliminates BC breakthrough under most conditions except the common 40m problems at night, the two stage filter gives good bandwidth and enough audio to drive a speaker. The 1496 mixer is a vast improvement and the DJ1ZB RIT circuit allows not only RIT but controlled T/R offset for each band.

SWITCHED BANDPASS FILTERS

Remove preselector gang and mount a 1) inch square panel on existing holes to accept a two pole three way switch (half of 4 pole/3way). Hard wire the PCB to switch with 16 g for rigidity, only three connections needed: in/out/ground. Remove L1 as shown and make good signal path by shorting 2 to 1 with link wire.

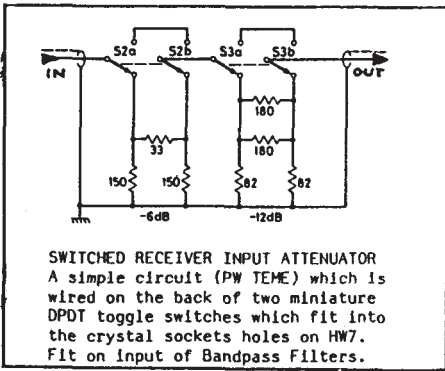

SWITCHED BANDPASS FILTERS

	T1/2	C1/3	C2
40	KANK3334R	100p	8.2p
20	KANK3335R	100p	3p
15	KANK3335R	47p	4.7p

REMOVE L1 COIL

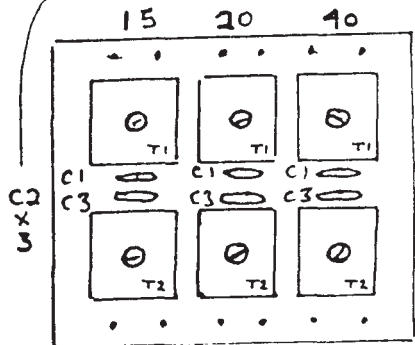
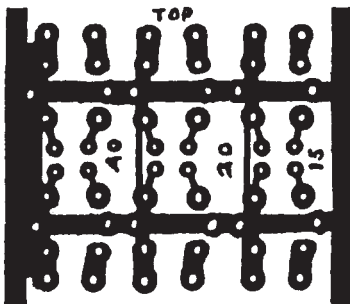
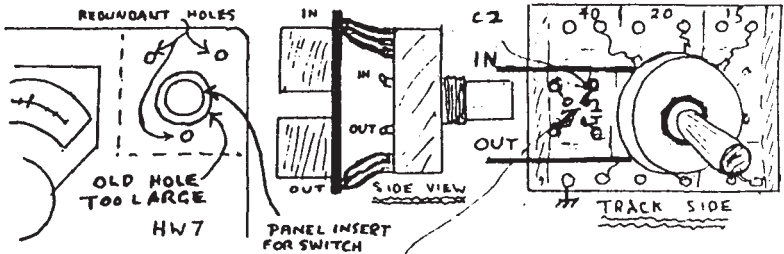
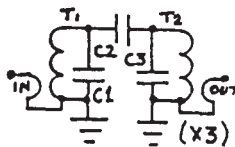

AUDIO CW FILTER AND AMPLIFIER

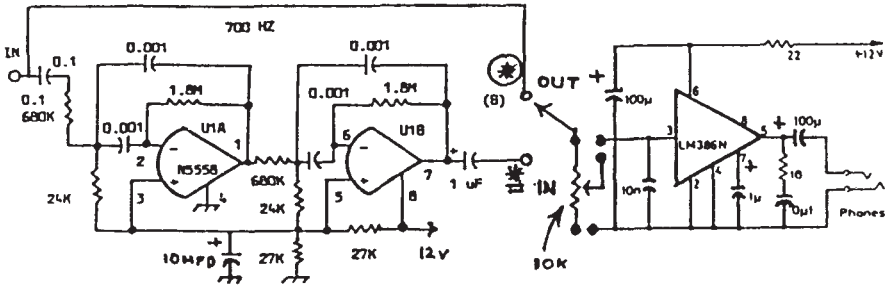

AUDIO CW FILTER AND AMPLIFIER

Remove wire from audio out jack, connect to input of filter. Cut tracks (3) under Crystal TX switch, which becomes "Filter In/Out". Make good signal path by shorting 4 to 5 of isolated tracks as shown. Leave existing volume control but disconnect 3 wire from PCB and mount 10K preset on underside of main PCB to preset input to new audio stages without overloading. The front panel volume control is now wired to the new audio board as shown. The output of the sidetone oscillator will require re-routing to the LM386. I have also made the input resistor (680K) a preset 470K to adjust gain into the filter (try it)

PRINTED CIRCUIT BOARD OFFER

Complete Set of FOUR PCBs for this article £4.00 inc. postage from: Dave, G4WZV. (see page 6)

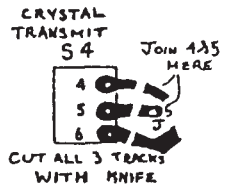

TOP OF VOLUME CONTROL AND CENTRE-FILTER SWITCH

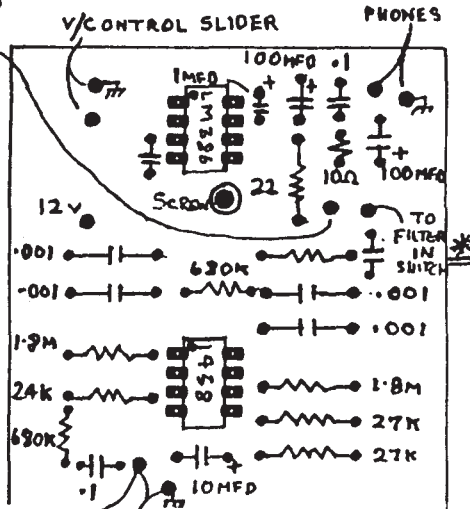
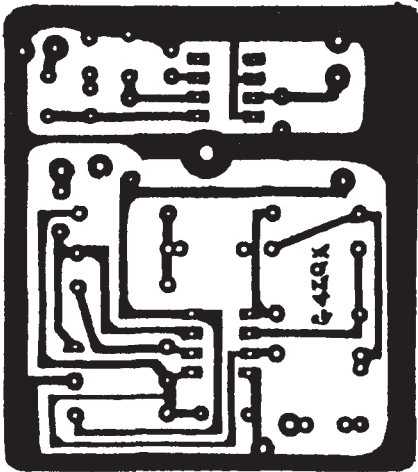

* FILTER OUT/INPUT FROM SWITCH AF PRE AMA

REPLACING THE FET MIXER WITH AN LM1469

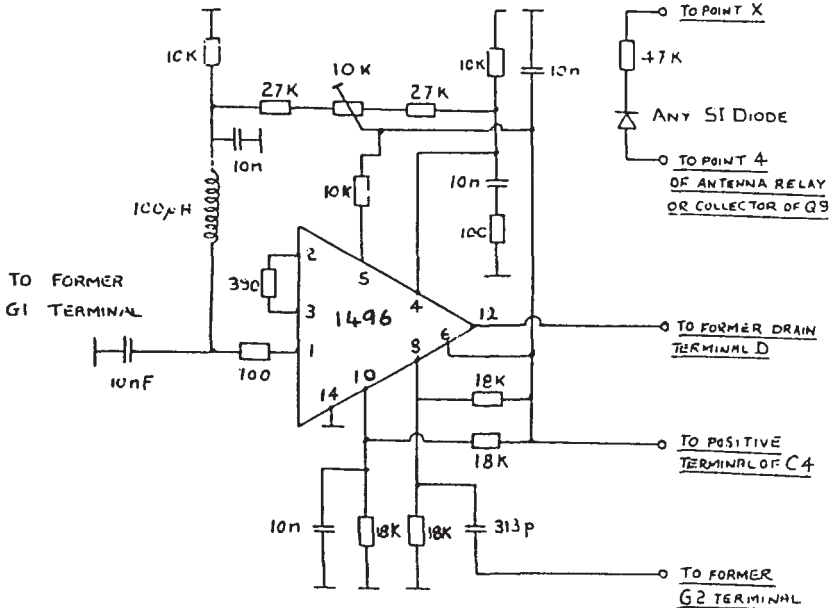

REPLACING THE FET MIXER WITH AN LM1469

The circuit is that of Ha-Jo Brandt, DJ1ZB, from the G QRP CLUB CIRCUIT HANDBOOK page 71, reworked for the common 14 pin DIL LM1496N. The dual gate FET mixer is removed with its gate 2 divider resistor. The preset is adjusted for best AM broadcast suppression. See original article for full details.

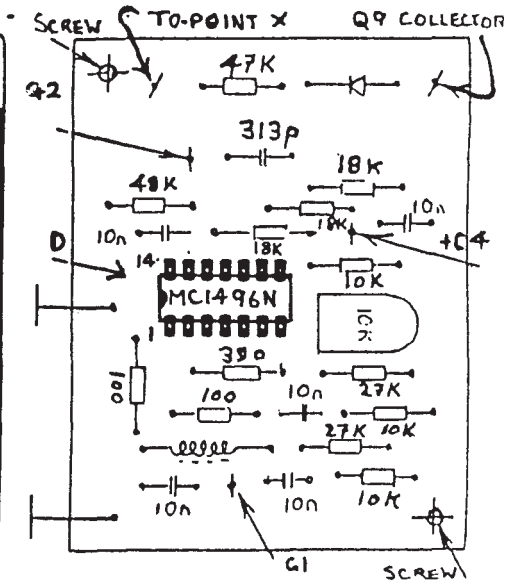
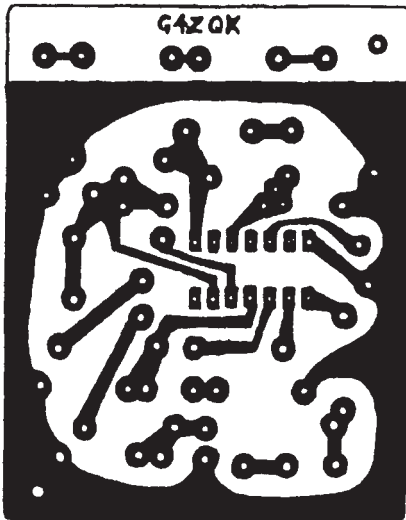

RIT and OSCILLATOR SHIFT COMPENSATION

RIT and OSCILLATOR SHIFT COMPENSATION
 Again by D11ZB, CIRCUIT HANDBOOK page 72, provides not only RIT but fixed transmit/receive offset on all bands and a "SPOT" facility for netting onto other stations by "zero-beating". See original article for full details.

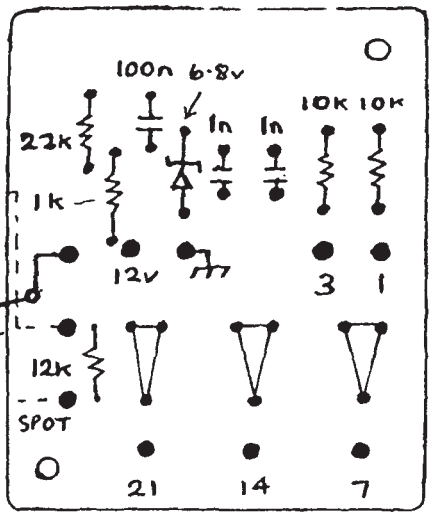
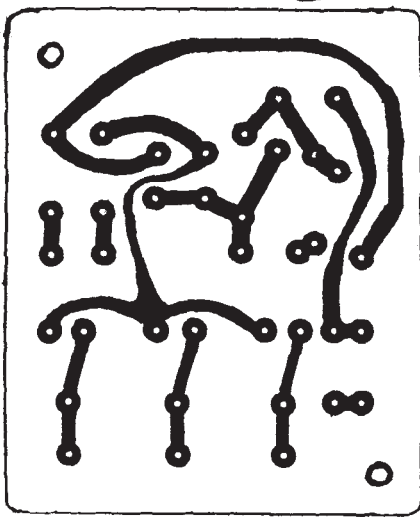
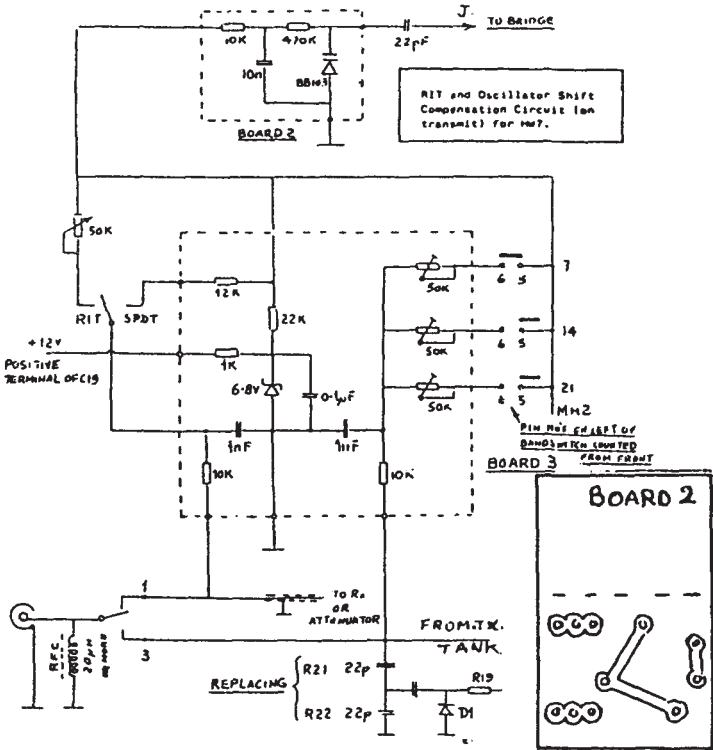

Author's Note: Bill, G4KKI has carried out these mods on his HW7, he now works VKs on 20m and is so pleased he is giving his wife an extra 50p housekeeping!

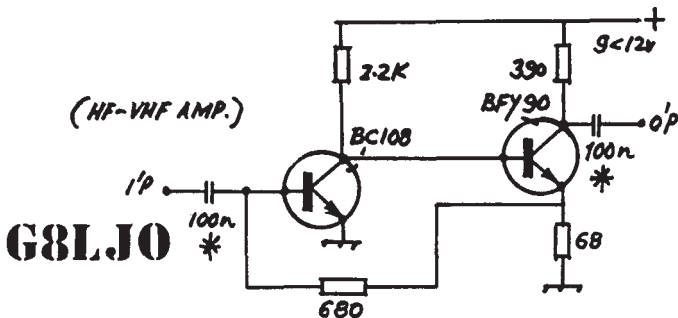

* SELECT FOR OPTIMUM RESPONSE

BROADBAND AMPLIFIER
W. J. Rickett G8LJO

This amplifier has an upper 3dB point at about 150MHz. Voltage gain (50 ohm source and load) of 24dB. Noise 3 -4 dB at 100MHz. Input imp. 10 ohms, output imp. approx. 390 ohms. It has been used by me to buffer inputs to frequency counters, oscillator outputs etc. for about 15 years. I have no idea where it came from.

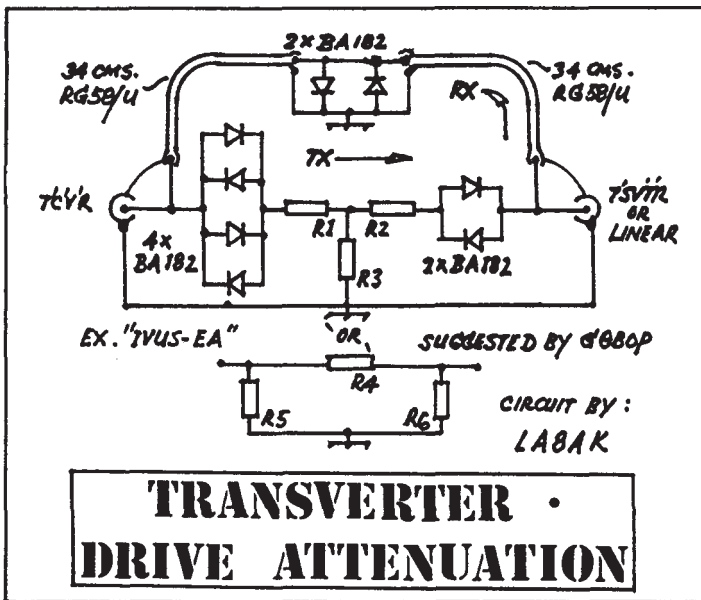

TRANSVERTER • DRIVE ATTENUATION

The following circuit designed by LABAK appeared in IVUS-EA, a specialist VHF newsletter edited by EA3LL. The text was in Spanish but the circuit explains itself. It may be useful for controlling transverter outputs used to drive external PAs for QRP working, or indeed driving transverters.

THE "ONE FOR ALL"
Ken Craven G4LKP

Weary of 9V batteries in multimeters, dip meters, etc. running down through being inadvertently left on, I removed the batteries and fitted all of my 9 volt test equipment with 2.1mm power connector sockets. One 9v nicad in its holder connected by a lead to a 2.1mm plug is used to power each instrument as required. A tethered 'roller ball' refill cap fits the plug end for added safety..

FILTER MODS FOR THE HW-9
Cam Hartford N6GA

The HW-9 has proven to be a very able and welcome successor to the HW-8. With its superhet receiver and full complement of WARC bands, it packs lots of features into a small box. After a year of QRP contesting, portable operating, and a crack at Field Day, however, I had identified a few areas in which the HW9 could use some improvement. Apparently I am not alone, for there have already been a number of modification articles published for this rig.

My first area of concern was the IF Crystal filter. This is a CW-only rig, so I expected a good bit of selectivity in the IF. I was disappointed to discover that the filter had a very broad passband, broad enough in fact that SSB signals were easily copied. Even with the narrow audio filter turned on, a strong CW signal outside of the audio passband, but inside the IF passband, would pump the AGC and make it difficult to copy the desired signal.

A call to Heath brought a new filter, but no change in performance. I peeled open the original filter and found it contained two three-terminal devices that were later identified as monolithic resonators. Referring to Hayward's article in QST, I reworked the capacitances around the resonators, I always came up with a passband that had two distinct peaks, separated by about a kHz.

Feeling that I had reached the limit of my knowledge, I decided to punt and enlist Wes' help. He very graciously agreed to look into the situation. I sent him the old filter plus a schematic. and the results were just short of dramatic.

The filter, as it turns out, is fairly broad and not very well terminated. Wes' measurements showed that it has a bandwidth of about 3 khz, with no way of making it into a cw filter. To quote his letter to me, "It is, however, a reasonable filter to use in a simple SSB receiver or transmitter....Don't throw the filter away, but don't use it in the HW-9."

Wes then obtained three 8.83 MHz crystals, and with the help of his computer model, transformed them into a real cw filter, seen in Fig.1. Very conveniently, the filter uses standard values of caps, and has 50 ohm end terminations. The 3 dB bandwidth is about 450 Hz, with good steep skirts, making it a real fine CW Filter.

Another problem area in the rig is the IF amp which follows the diode ring mixer and precedes the crystal filter. This amp must provide a proper termination for the mixer, and the JFET chosen for the job won't do this. A better choice is a bipolar transistor with high standing current and heavy negative feedback, such as the one in Fig.2. Wes has used this circuit successfully in other applications, such as the Progressive Receiver, November 1981 QST. A 2N3866 will do well in this circuit, but needs a heat sink because of the fairly high standing current (50 ma. or so). I had to reduce the value of the 100 ohm resistors in the schematic to 47 ohms to get the 50 ma. standing current.

I etched a small circuit board to hold both the amp and filter. After removing all the unneeded parts from the main transceiver RX-TX circuit board between the SBL-1 and IF chip I mounted the new filter board just above the main circuit board, suspending it on its power and signal leads. Power is provided by picking off the +R voltage at the point where L304 used to be. It was necessary to do a little experimentation with the value of the capacitors in the BFO to get the passband of the filter back to where it should have been. W7ZOI suggests building a separate oscillator so that one can amp is used for the BFO and the other for the offset oscillator for the transmitter. I chose rather to stick with the Heath, method of using one oscillator to do two jobs by pulling it off frequency when the rig is keyed. It may be easier to build the separate oscillator to more easily obtain the correct offset for transmit.

After installing the new filter and post-mixer amp, I noticed a very distinct improvement in the receiver. The IF now has a true CW passband, and with the audio filter switched in, the selectivity is on a par with that of some much more expensive commercial gear. The effect of the new post-mixer amp is also quite gratifying. Prior to the change, I attempted to operate in a North American Sprint, which is a contest populated mostly by full gallon CW ops. The HW-9 fell apart in the face of these monster signals. After the operation, however, the patient's dynamic range and selectivity were much improved, and I was able to operate the entire Sprint to the tune of 100+ QSOs. Quite a

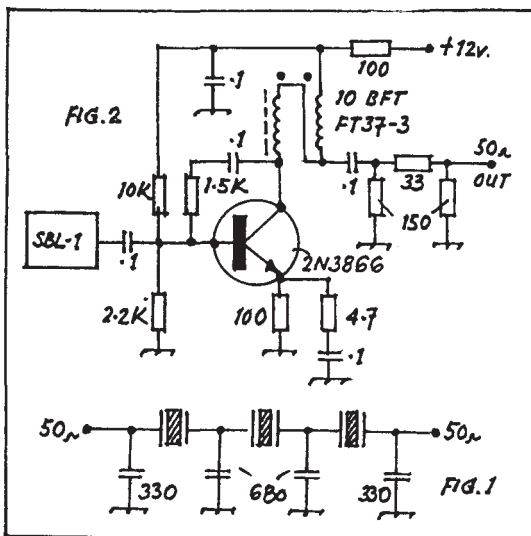

Another area that needs to be attended to is the audio filter. Wes pointed out to me that some of the values in the narrow audio filter are poorly selected. Indeed, in my schematic, one section of the filter uses 15 Megohm resistors and 100pf capacitors, whereas the other section uses 1.5 Megohm resistors and 1000pf caps. The latter combination is preferred, for it gives rise to much less noise than the former.

I was at the point of pulling the offending parts from my rig and replacing them when I discovered that both sections of the filter had the same (and proper) values. Perhaps a change was made in the production run for my rig without the change being noted on the schematic. In any case, it is a simple change to make, so I suggest that you check the actual values of the parts in your rig to see if they are the preferred values, and don't depend on your schematic.

In addition, the op-amp used in the audio filter is an LM-324, which uses a class B output in each section. A 2.2K resistor to ground from each output will force it into class A, thus reducing any cross-over distortion that may occur under some circumstances.

I'd like to thank W7ZOI for his time and helpful suggestions. While this is not a step-by step construction article, I believe the ideas presented herein will provide the experimenter with some very useful ways to help turn the HW-9 into a really fine little QRP rig.

(From July 1988 The QRP Quarterly)

NON-ETCHED PCB IDEA
BOB LEASK G4CEO

I came up with the 'non etch PCB'. My local computer shop sells both single sided and double sided copper clad PCB, off cuts, unetched.

In a nutshell, cut the size you want, of single sided PCB, put the components on the copper side with leads poking through to the unclad side. and wire them up ugly style. Leads to be earthed can be soldered to the copper direct and you have a continuous ground plane. One word of caution. Where the component leads go through the copper to the other side, there's a risk of them shorting to the ground plane, so I use a veroboard spot cutter to take away the copper around the drilled holes on my 'non etched PCB', so there's now no risk of shorting to earth.

I've made a few PA circuits this way and have no problems with instability, as leads to be earthed can be reduced to almost zero length - providing you're quick with the iron.

The TEN-TEC Argonaut as anyone who owns one can verify has an excellent receiver and when conditions are unsuitable for QRP operation can with a few minor mods. be used with an external transmitter.

This can be achieved as follows.

Remove the bottom cover and fix a small flat (PCB type) 12V relay to the rear panel using double sided tape. Drill a suitable hole in the rear panel and fit a phono socket. A small piece of wire may now be soldered between the phono centre pin and one side of the relay coil. The other side of the coil can next be wired to the hot side of the panel light switch.

Remove the top panel and locate the control board. Having found this unsolder the wire from the R voltage terminal and extend this with a short piece of insulated wire. A further piece of similar wire can now be soldered to the vacant "R" terminal pin on the control board. Both these wires can now be threaded between the boards to the newly installed relay and connected across the normally open and common terminals of the relay. A second phono socket can now be fitted to the rear panel and the centre pin connected to the hot side of the speaker.

OPERATION

Fit a shorted phono plug to the phono socket connected across the relay coil this will allow the rig to work normally and complete the "R" voltage cct.

For use with an ext. transmitter remove the shorted phono and insert a phono plug wired to the normally closed contacts of the transmitter to be used. The phono plug wired to the speaker can now be connected to the Tx anti trip cct if the use of VOX is envisaged.

I have also changed the ant. socket from phono to BNC this is purley optional but if does make for a secure connection and quick change-over to the other station equipment in the writers shack. I have used this arrangement for quite some time in conjunction with a KW Viceroy Mk 3 which is an excellent Tx and a good example can now be found for around 40 Pounds.

If you are a QRP purist then pop in a key and turn the wick down but you do have the choice of a little extra push should that rare prefix appear amidst the QRM. The excuse for an accessory socket on the Argo 515 has been changed to a DIN type socket. If this is done a DIN plug will have to be inserted with a link between the audio out and audio in pins unless of course the optional audio filter is in use.

The transmitter Receive Ant only may be connected to the Argo antenna socket and check that this is grounded during the transmit cycle. Release time on a relay is normally quicker than make time this will explain why the normally open contacts have been used also should the relay coil go open cct you have a fail safe situation. The price paid is the modest current drain during the receive cycle.

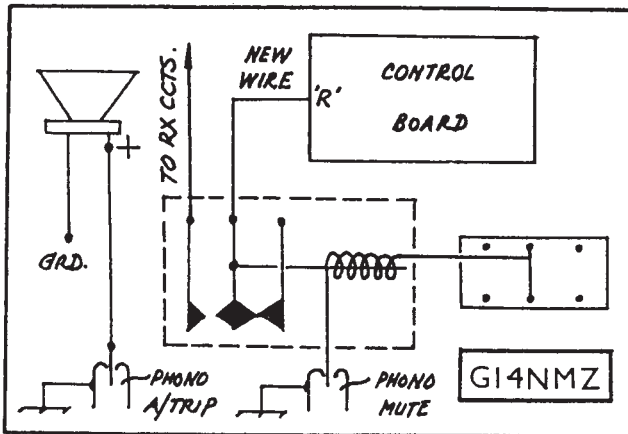

THE G-QRP CLUB "SPONSOR A MEMBER" SCHEME
Membership Secretary, T David Jackson G4HYH
Castle Lodge West, Halifax Road, Todmorden, Lancs. OL14 5SQ, England

As a number of our readers will know, we have for a few years operated a "sponsorship" scheme. Members in certain countries have great difficulty paying subscriptions to the club. Other members who have no such problem have contributed an extra subscription (sometimes two extra!) to assist those of our friends who have genuine problems.

At the time of writing (9th April 1989) there were in total 26 members being helped in this way.

I would like to take this opportunity to explain how the system works.

1. When a member sends an extra subscription for a "sponsored" member I make a record of the payment.
2. If the payment is stated to be for a particular member, that fact is also recorded. I don't normally write to the "sponsor" under these circumstances.
3. If the payment is made into the general "sponsorship" fund I allocate it to a member as I find it necessary. When the payment is used I notify the "sponsor".
4. If you have contributed to the scheme previously I try to use your payment for the same member each year. In that case I do not write to you.
5. As I write this I have a few "spare" payments (4). It is very useful to have these spares ready for use when they are needed.
BUT : THE G QRP CLUB IS BECOMING QUICKLY KNOWN IN RUSSIA AND SEVERAL APPLICATIONS WHICH REQUIRE SPONSORSHIP ARE EXPECTED SHORTLY.
If you are a new "sponsor" and you haven't heard from me it means that I have not yet had to use your payment. I haven't forgotten about it!!!

May I thank all of you who have contributed to this system. The thanks are from myself and the other Officers, and, most importantly, from those people for whom membership has been made possible. It is all part of that "ham spirit".

NOTE ABOUT STANDING ORDER CREDIT TRANSFERS:

There have been some problems with credit transfers made by standing order. Some banks have mis-read the form and credited the payments monthly! G4HYH will contact any such members as the problems arise.

VHF DXpedition - Operation Trans Atlantic Challenge
Glyn Dodwell G4CFS

Royal Air Force Finningley Amateur Radio Society is planning a VHF DXpedition to the Mull of Kintyre during the month of July to investigate trans-atlantic propagation on the VHF frequencies, (144 - 146Mhz), by making use of the following propagation mechanisms, sporadic E. tropospheric ducting, meteor scatter, EME and aurora. During the period 16th - 30th July the society will be operating a high power 2 metre station in addition to 4 and 6 metre stations.

Whilst this may not be of direct interest to the members of the G-QRP Club, as an addition myself, G4CFS *4298, and club member George G4AWT will be installing and maintaining a QRP station on as many HF bands as possible for the duration of the expedition. Operation will be on an opportunity basis, fitting QRP work in around our individual watches on the VHF station, but we hope to operate for approximately 8 hours a day QRP.

Callsigns to listen out for are GB2TAC, GM4CFS/P and GM4AWT/P. Should any of the North American readers of SPRAT be interested in monitoring our trials the frequencies follow;

Callsign GB2TAC
Frequencies

2 metres 144.010 CW call and beacon
144.225 SSB calling.
4 metres 70.144 CW & SSB calling
6 metres TBD
HF Control Station 14.330 and 21.330 SSB

INFORMATION FROM:
Glyn D Dodwell G4CFS
Operation - Trans Atlantic Challenge
15 Wroot Road
Finningley
Doncaster
South Yorkshire
DN9 3DN
Telephone : 0302 770747

1989 SUMMER QRP PARTY

Pam and Chris, G4BUE will be holding their sixth annual Summer QRP Party at their QTH in West Sussex on Saturday 19th August 1989. It starts at 2pm and will end when everyone has gone.

All members and any other amateurs interested in QRP are invited. At the present time OK1CZ and four of the PA QRP gang will be staying over the week-end, but other accommodation is available for any other overseas or members who will be travelling any distance. Depending on what degree of comfort you require will depend on how many members can be accommodated! If in doubt get in touch with Chris.

The Summer Parties started in 1984 to enable Ade Weiss, WORSP, who was staying with Chris, to meet some of the UK QRP gang. Since then they have been a regular summer event. If you've got anything to sell, you've just built, want to show off or get to work, or want to try out on Chris's antennas, then bring it along. There is no formal programme - just come and do as you like: talk QRP, operate, tinker, read QRP books/magazines, get a sun-tan (hopefully!), eat and drink!

Everyone is welcome as space is not a problem, at least it hasn't been in previous years! Please let Pam and Chris know you intend going so that sufficient food and drink can be available. They can be reached on 0903 814594 or by post to "Alamosa", The Paddocks, Upper Beeding, Steyning, West Sussex, BN4 3JW.

Mini-Convention Rochdale 1989

A NORTHERN GATHERING FOR QRP CLUB MEMBERS
SATURDAY 28th OCTOBER 10am to 5pm
ST. AIDAN'S HALL, MANCHESTER ROAD, ROCHDALE, LANCs.

- * Gather and Talk * Full Lecture Programme * Display of Equipment * Lunch/Tea *
- * Bring/Buy/Sell/Swap Stall * Component/Kit Stalls * Construction Prizes *
- * HF QRP Station * G3RJV's QRP Archive + Photocopier * Talk-in on 522 *

***** HOW CAN YOU JOIN IN ? *****

LOCATION: Easy to find : Off Junction 20 M62 (Rochdale) Left at roundabout at end of feeder road, left at next roundabout (by Tesco Store), Straight on at next roundabout (Castleton), St. Aidans 50 yards ahead on the right. Parking on Manchester Road or, better still, in giant Tesco carpark and walk 50 yards.

BRING: Your Home Built Equipment (whatever standard or craftsmanship). Items for sale or swap (equipment, junk or components). Food and Drinks are available.

FAMILIES: Might like to explore the lovely Pennine countryside nearby or even shop in Manchester (about 15 miles away).

***** CAN YOU HELP ON THIS FIRST EVENT BY BOOKING IN ADVANCE *****

As this is a first for the club and we have no idea of your response, we need to be able to estimate catering and space allocation for your comfort.

Therefore we are asking members to book in advance.

Please send (to G3RJV) £1 (Cheques:G QRP CLUB) with your CLUB NUMBER, CALLSIGN, and NAME. You will then be able to check-in at the door and receive a free prize ticket and programme.

HELP * HELP * HELP * HELP * HELP * HELP * HELP * HELP * HELP * HELP * HELP *

The club maintain a filebox of master copies of every issue of SPRAT held by G3RJV. Unfortunately these are not available for loan since a member once borrowed one of everything and lost some of them. A recent check reveals that we do not have a copy of SPRAT 24 - Can anyone supply or loan one for copying ?

WANTED INFORMATION on two audio chips : SN76013 and TBA800 by Tony Edwards, G3HNP, 5 Greencourts, Winterton-on-Sea, Gt. Yarmouth. Norfolk. NR29 4A0.

CONTEST REMINDER

AGCW-DL-QRP SUMMER CONTEST : 22nd and 23rd of July 1989 : Rules as published

WE REGRET TO ANNOUNCE to deaths of the following members : Ron Dow (G4LHK), Arthur Bain (G3DEV) and A.B. Gibson (GOAVJ).

QRP Communications Forum

Gus Taylor G8PG
37 Pickerill Road, Greasby, Merseyside L49 3ND

WINTER SPORTS 1988 - A CRACKER! The G4DQP Trophy goes jointly to Randy, AA2U, and Chris, G4BUE, for their contacts on 8 hf bands (one cross-band). They are congratulated on what is undoubtedly one of the most outstanding QRP achievements to date. Overseas certificates of merit go to Andy, WB2RZU, and Jim VE2KN, for their excellent trans-Atlantic two-way contacts. There were so many outstanding European logs that judging became something of a nightmare! Eventually the selection was narrowed down to G3PDL, G3XJS, and G4JFN. GM30XX would also have been a major contender, but being the outstanding sportsman he is George marked his outstanding effort "check log", thus giving others a chance. HF band logs from all major contenders were so good that judging eventually came down to 1f band two-way QRP DX contacts. G4JFN was thus judged runner up with two Ws on 3.5 MHz, and one on 7 MHz. G3PDL came third with one W on 3.5 MHz (he also got his 3w across on 1.8, but sadly the W was QR0). The best difficult location log was from Bill, G4KKI, operating from a difficult big city location. This year the award for activating an unusual country on QRP goes to a non-member (he is joining), namely Stan, EA6ZY who gave a new one on two-way QRP to a number of members. So, having dealt with the Big Guns, what about the little guys like you and I? Firstly your logs are invaluable for analysing the event and getting a real picture of what happened. Secondly, all Big Guns start as little guys, and it is events such as the Sports that give them the incentive and experience to sharpen up their skills, equipment, and antennas and thus reach the Big Guy level. We can all do the same if we try! Finally, we all had fun, renewed old friendships, and made new friends. That is what the Sports is all about. Thank you all for participating.

CHELMSLEY TROPHY 1988 goes to Hans, HB9XY, who made nearly 1000 contacts during the year using QRP and simple wire antennas. He worked 50 DXCC countries, 26 countries on two-way QRP, and 5 continents. Well Done OM!

AMENDMENT TO CHELMSLEY TROPHY RULES. In response to requests the antenna rule has been amended to allow the use of horizontal loop antennas not more than 75 x 25 feet in size, and 35 ft in height. The popularity of this type of antenna is increasing rapidly. This change is effective from 1 January 1989.

THE OK/G ACTIVITY WEEKEND produced activity from no less than 15 OK QRP stations and 57 of their G counterparts. It was thoroughly enjoyed by all. The leading G stations were G3VIT, G4CF5, and G3D0V, and the leading OK stations were OK1AYH, OK1DKR, and OK1OFM. One happy participant was OK1HBT who worked VS6VT/QRP on 21 MHz. All leading stations will receive awards. G/OK contacts were made on all bands 3.5 - 21 MHz. We (OK1CZ/G8PG) hope to organise a similar event next year. We are also looking at the possibility of an all-Europe QRP QSO Party to replace our October Difficult Locations Week-end. Watch this space. Finally, thanks to all our Czech friends who helped to make it such an interesting weekend.

3.5 MHZ DX PERIODS IN NEXT WINTER SPORTS - ADVANCE WARNING. During the 1989 Winter Sports please assist in leaving 3560 kHz clear for trans-Atlantic two way QRP working between 0600 and 0900 on 29th and 30th December. If you wish to work local QRP during these periods please more up around 3570 kHz. Better still listen for our W and VE friends and see if you can work them. Ewew hearing a QRP W on 3.5 should be a big thrill. Will the big antenna men please give us small guys a chance - once you have got across let others in - or even help to put them across.

THOUGH THE SUMMER SUN MAY BE INVITING do please try and spend some time in the shack during our Summer Ramble between 12th and 18th June, and particularly on 17th June, which is international QRP day. On that day you could qualify for the Suffolk Trophy by submitting your log. You can find full details near the back of your Members Handbook. Do please support the Ramble.

WILL OUR TOP BAND ENTHUSIASTS please contact Bob, G3IQF, with a view to organising regular activity on the band (R.Fowler, G3IQF, 2, Fieldhouse Way,

CHANGE OF MODE. A certain well known Clerical Member of our Club was recently spotted on QRO TV and co-starring with Archbishop of Canterbury no less! (BBC "Look North", 21 February 1989).

I AM PUZZLED by the remark which Rocky, W9SCH, made about "the haughtiness of some of the FOC set" in our last issue. Out of the 10 Club officials listed on the back of our Members Handbook, no less than 4 are FOC members, one having over 50 years in FOC. One thing no one has ever accused them of until now is being haughty!

THE DJ4GA DISCONE ANTENNA was designed for 7 MHz DX. I scaled it down for 28 KHz use in my loft. It has proved terrific on DX. To make it cut two 16 ft 1) inch lengths of wire. Erect one length horizontally and attach the middle of the second length to its centre via an insulator. Arrange the second length as an inverted V with a spacing of 11ft 2 ins between its two legs at the open end. Feed the antenna at the centre of the two wires via 75 ohm twin or a 1.1 balun and 75 ohm co-ax. With no trimming swr was virtually zero 28.00 to 28.5 MHz. I will not list the new DXCC countries added to my score - might make you jealous! Can be scaled up for other bands of course.

TO QUALIFY for the Worked G QRP Club Award or the Two-way QRP Award the whole QSO must be made at QRP levels. If QRO is used in either direction at any time during the contact it can not count.

MY THANKS to all those members who wrote to express their appreciation on the piece about QRP operating proficiency in the last issue of SPRAT. It is obvious that they found it helpful, and also that many active members appreciate the attempts made in this column to be helpful, constructive, and non-controversial. An encouraging feature in the several hundred letters dealt with each year is the way in which members who are old is years but young in operating experience work so hard to improve their operating and technical proficiency. I am all for encouraging the young (I became G8PF at age 17), but the shift in the age of our population means that more and more mature people are available to be attracted into amateur radio. Our own Club does well in this respect; some other organisations do not yet seem to have woken up to this fact of late-twentieth century life.

AWARD NEWS

NEW QRP MASTER. Congratulations to Charles G4MEW

QRP WAC; G2DAN

QRP COUNTRIES. 175 G4JFN (well done!); 75 G4MEW; 50 GI4DQO.

WORKED G QRP C; 640 G4JFN (well done again!); 300 G2DAN, G3MBN; 160 G4XVE; 140 G4UGZ, G4CFS; 120 GWOODNR; 100 G3FCK, G4UYE, GOFTO, GOFYP, 80 GOCQA, G3INZ, GOIFK; 60 G4MEW, G4VJPF, GOBOP; 20 I3MDU, G4AWT.

TWO-WAY QRP; 40 G4JFN, G3XJS; 20 G4MEW, G4XVE, G4CFS; 10 I3MDU, G4WUS, GWOODNR, G3INZ, G3FCK, G4AWT. (Early deadline. Above covers to 17/4/89.

WANTED: Argonaut 515 (or 509) for portable working. John Davey 0252.549387

INFORMATION WANTED on TAYLOR Valve Tester Model No.45D. Please contact Alan Lyttle G4VGU, 23 Heathfield Dr. Blackwood, Lanarkshire. ML1195R. 0555.892370

HF CONVENTION : Lift wanted to convention in Oxford later this year by Angie Sitton, GOHGA, 29 Hudson Rd. Stevenage, Herts. Anyone near Angie going?

SWAP: Can anyone make use of RX BC348R, with handbook, but no PSU (easily built) Will swap for working TX 5-10 watts 7MHz upwards, or W.H.Y. in QRP line(no RXs) Also require info on Ham Radio related software for Atari 8000XL on disc. Need source of supply, or would purchase copies, DOS 2.5 format. Tony Tuite, Bod Afon, Brynmor Trce; Penmaenmawr, Gwynedd.

MAGAZINES FOR SALE : QST Jan 1968 - Dec 1986 (19 years) BULL AND RADCOM Jan 1965 - Dec 1987 (23 years) SHORT WAVE MAGAZINE 54 issues between 1979-86 (many G3RJV articles). Negotiable, Buyer Collects (Glos.) TEL: 045 36 3994

WANTED: Argonaut 515 - Bob GOFTO, Bolton (0204) 657410.

SSB News

IAN KEYSER G3R00
Rosemount, Church Whitfield, Dover, Kent

Well, Sprat has only just fallen on the mat and here we are at the typewriter again. The reason for this is George and I are off to the Dallas convention to do our bit. The deadline date has been brought right forward to get SPRAT ready before we go.

The conditions on the bands over the last three months have ranged from fantastic to dead, the aurora effectively killing them last month. Prior to that I was working all continents each week on SSB at 10 watts. As far as CW QSO's, I have been working the States on milliwatts, the best being 5mW to WIDMD and he gave me 339 on ten metres. We established QSO at 5 watts and reduced power.

On the question of QSL's, all my phonecalls have been very encouraging but I wonder why some of you wrote to Chris, this bugs me a little because you increased Chris' workload on my behalf. Is it because you think I would have been unfair with the results? I hope not, if I thought that was the care I would leave my post in the G-QRP club immediately.

I have, so far, been accused of all the comments, good and bad, in Chris' last piece plus bring the QRP club into dis-repute. However I have also had many calls of support, typical examples being from Frans Priem, PA0GG (Nr 1 B.Q.C.) and Colin Turner G3VTT. I am not going to list them as that would be a waste of space, but I would like to clarify a few points. Firstly I have QSL'd club members 100 percent either via the RSGB or SPRAT, if you have not received a card within six months of the QSO either you did not work me or you have no envelopes at the RSGB! I have tended to use RSGB because the local club has a collection box. Secondly my primary comments were to those who QSL'd direct and expected me to do the same, I repeat, I will not do it without SAE.

But why do we QSL? There are a few who collect the cards for the cards sake, as an avid collector of Morse Keys, old radios and headphones I can feel for these members and will always QSL. The other section of the community, SWL's, their hobby is QSLing and so I will respond. But for awards which depend on TRUST that the chaser will keep to the rules I fail to see the reason. Colin sums it up another way, Amateur Radio is for building and operating, not for pushing paper, let's reduce the paper and increase the Hobby.

For those who have commented that there is a rift between Chris and myself as far as I am concerned there is no rift. Also after QSO's and phone calls to him I do not detect any ill feeling. We disagree on a point, but that does not mean to say we are bitter enemies, especially over something so trivial!

This will be my last but one comment on this subject in the press, however, for those out there who agree with my sentiments and wish to see this situation resolved, take heart, I am discussing this in committee and my last comment will be concerning the outcome..

STOP PRESS NEWS.....

A SIX METRE QRP QSO PA - LU

A phone call from Peter Halpin, PE1MHO, announced that he had worked LU9AEA on 6m SSB using a power output of 2.755 watts from a lash up PA using a single VN66AF. Peter had his 6 el beam point to Gibraltar during an Es opening and heard the LU. He called and had a short QSO : 5/8 and 5/2 at 1853 gmt. Currently Peter and G3R00 have been trying evening skeds at 1800 gmt, beginning on 144.380MHz and if failing on 50.160MHz.

The 80 METRE SSB CLUB SKED RETURNS.....

MONDAYS AND FRIDAYS AT 1600 UK CLOCKTIME : 3690 (International SSB Frequency)
Listen out for G3R00 and G3VTT and join them

Members News



Chris Page G4BUE

"Alamosa", The Paddocks, Upper Beeding,
Steyning, West Sussex, BN4 3JW

being promoted by David G3OEP again.

G4LGX invites anyone in the Ripon area to visit the Ripon and District ARC, (G3SJM) where there is keen interest in QRP. John can be reached on 0423 567390. Look out for David Gosling (4819) when he gets his call. His interest in amateur radio started as a result of Channel 4 TV's Open College Electronics Course. This led to building the Lake Carlton RX followed by the Heathkit SW7800 RX which took him 65 hours and worked first time. David does a lot of listening and congratulates G0DSB who got through a crowded band to work GB2SM with 3w. G4BCY operated from GB4BKA in the Bee Garden of the National Agriculture College at Stoneleigh at the end of April. John's other hobby is bee-keeping.

That "milliwattin'" stalwart W9PNE has been at it again. How about a WAC in 1 hour and 56 minutes with 20mW? Brice did just that in the ARRL CW Contest and then the last one (Africa) took him half an hour to find! Some people don't believe him when he tells them he is running 20mW so he QROs to 1w and "blows their ears out". If they still don't believe him he fires the IC725A up at 100w and they then know! G4WUS sends information on a 59dB attenuator from a Radio and Electronics World article. Bill is building it to use with his TS530 and will report further. So far he has worked KV7X with 190mW and he says "oooh the joy of QRP".

G4JFN only needs zone 2 to complete his WAZ. Bob should look out for W6JHO between now and the middle of August. Al will be QRV from Alaska, Yukon and NW Territories as /KL7, /VY1 and /VE8 with a Century 22 at 5w and a Hustler vertical. OK1CZ needs 16 cards to complete 3 band DXCC. K6MDJ is looking forward to the US Field Day with the Zuni-Loopers again. G0EBQ is now using his Imp on 30m as well as 20 and 40m as it is a nice quiet band. Nigel has just acquired a 1940 ex-army Mk2 key for £3 from a junk shop which he says is a big improvement over his modern Japanese one.

The experiments of OE6HS on modulated infra-red laser beam transmissions reminds G3ESP of his WW2 years. For three years Walter was concerned with investigating captured army signals equipment, amongst which was a "Lichtsprecher" (German) which translated meant light speaker.

Walter says the (QRP) model 80 had a 4w bulb for a sender source, the output of which was focused onto a parallel beam by an 80mm dia lens. A carbon mike and 2 valve amplifier optically amp-modulated the light. This entered the opposite receiver through another 80mm lens which focused it onto a photocell where a 3 valve amplifier fed a pair of headphones. The QRO version had a 250mm lens and in North America the US Army got S9 over a distance of 20 miles. Walter has an illustrated manual of information on German Army WW2 signals equipment and would be pleased to help any members requiring information about them on receipt of a SAE.

PA3BHK hopes to be free of his studies by August to visit "Alamosa" for the QRP Party. Robert mentions the aurora of 13th March and how bright it was in the sky. With 4w to a 9el at 40ft he worked OM and I. Another member with studies is G0GWA who found time to work 4Z4

on 40m with 2w with his inverted vee. He used the same antenna on 15m in the ARRL Contest and worked 32 States. Simon hopes to visit TA in July and will be taking a 21/28MHz QRP rig with him. OK1CZ is building a new memory keyer and an all band hybrid transceiver with solid-state and valves. The TCVR is for Petr's father OK1DJJ who has recently returned to amateur radio.

Congratulations to GOHGA who has taken over from G3VIT as the Club's representative for the European CW Association. We all wish Angie the best of luck. G4ECI says he is truly hooked on QRP. After screwing his TS530 down to 3w John worked around Europe with his G5RV and then real excitement as he called CQ and was answered by VE3, W9 and ZS6. He is now building Howes kits. Keep an ear for WF6U as Hollis is building a big three element quad. W9PNE is doing more work with small indoor loop antennas like the 3ft dia. one he had at Dayton in 1986. The 10w FT7 SSB signals of G3ESP interfere with his modern pushbutton telephones and Walter asks if any members have a cure for this? ZL4HB has heard G4AWT and G3UZU on 20m and worked GD3FXN (10w) on 18MHz. George met Bryce ZL0AKB who was touring ZL and turned out to be G3UOV.

Talking of touring ZL I am now going to turn the remainder of the column over to G4JFN to tell you about his recent trip to ZL: "Within a few hours of arriving in Hamilton on the North Island I made my first club contact when I telephoned Kevin, ZL1UJG and met him at our motel. Work QRM prevents him from too much operating but he does some homebrewing.

I had arranged to collect my licence in Rotorua and arriving there I went to the Radio Frequency Office and was greeted by Dave ZL1AV who issued me with ZL0ACF. Meeting Dave was great, since it was him that G3XJS and me had worked on two-way QRP from the UK. A long way to collect a QSL card! Dave invited us for dinner at his QTH at Lake Tarawera. His wife Hemi and son Bill welcomed us to what can only be described as one of the most beautiful locations on earth. The house is situated on a high cliff overlooking the lake with the mountains as a backcloth. Dave's large tower stands in a garden that contains so many exotic plants and flowers you would think it was a botanical garden. The station consists of a mixture of commercial and home brew gear and his collection of QSL cards is very impressive. He is a very active operator although only on 20m. When we eventually left I was clutching a precious QSL card!

We left Rotorua and headed south towards Upper Hutt and Trentham, the home of ZL2BJC. Iain was painting his house when we contacted him and as soon as I mentioned G-QRP-Club invited us over. Trentham is a built up area and the size of the garden regulates the size of antenna you use. Iain uses wire antennas which with his geographical location makes contact with the UK difficult. The ZL2BJC shack is the type you love to rummage around as Iain is an avid constructor and showed me several QRP rigs. I was delighted to have a club QSO with him, albeit on 2m, and then we settled down for lunch. This part of the north island is not good for HF due to the absorption by the mountains.



IAIN
ZL2BJC

Moving up to Palmerston North I visited ZL2BOI. Giovanni has another real ham's shack with a good mixture of commercial and home brew gear. I did some listening there but Europe was just dying out.

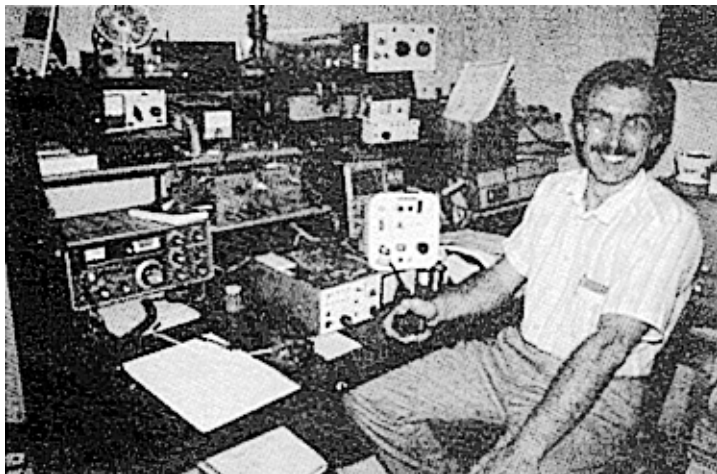

GIOVANNI
ZL2BOI

The next day we headed for the famous Mount Egmont and its conserved natural bush which could be better described as a kind of jungle but without nasty beasts or reptiles. Up and up we went until we reached the large parking area some way below the summit. Here we found a large wooden fire watch tower with wire VHF antennas attached to it. It transpired this day was the ZL VHF Field Day and on the car park were two cars containing contest stations. ZL2TUV and ZL2VKV must have had one of the most exotic field day sites it was possible to find.

For the next few days we wound our way northwards to Auckland using my ZL call on the VHF repeaters. The scenery is really beyond belief and no amount of words or film can possibly describe it. Following a QSO through the repeater in Orewa, just north of Auckland, I was called by ZL1TFI the Chairman of the local club, Hibiscus Coast Radio Society, ZL1FU. The next day we visited their club house, which is situated on the cliff edge one hundred feet above the sea. Next to it is a large field containing a partially constructed monster quad for 20, 40 and 80 metres.

It was a Saturday when we arrived in Auckland and the place was deserted. Despite several calls through the local repeater I did not contact any members, not even ZL1BLJ.

As an avid DXer I was most interested to find out what life was like on the bands in New Zealand, what was regarded as DX and in general about amateur radio down under. The few club members I met seemed to hold SPRAT in very high regard and appeared to do a lot of constructing. I made it clear that we in the northern hemisphere would love to hear from our antipodian members from time to time through the pages of SPRAT. Thank you all for your hospitality."

Thanks for completing my column Bob. Finally thanks for all your letters on the QSL controversy. I have decided to draw a line over the debate with those of you in favour of retaining QSLs, both for club awards and on a personal basis, winning hands down. If you cannot make Alamosa in August, let me know how your summer goes, by the 20th August please.

73, Chris

WANTED 6m SSB rig - your silly price paid!! Peter, PELMHO, S.Vestdijkstr 21, 7552-NR, Hengelo, Netherlands. Tel: 074 434967 or at the G4BUE Summer Party in August.

WANTED Information on the new Hamgear QRP Wattmeter, (five ranges from 0-10w to 0-1mW), priced £36. If you have one please get in touch with Chris Page, G4BUE, "Alamosa", The Paddocks, Upper Beeding, Steyning, West Sussex, BN4 3JW, Tel: 0903 814594.

SPECIAL SPRAT OFFER

CRYSTALS

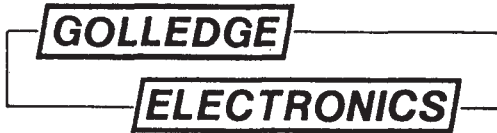

BAND	QRP CALLING CHANNEL	OTHER FREQUENCIES	MODE	PRICE	
160m	-	1850	Fundamental	£4.00	All HC-25/U, 30pF. 
80m	3560	3540 3550	"	3.50	
40m	7030	7025	"	3.50	
30m	10106		"	3.50	
20m	14060	14030 14040 14050	"	3.50	
17m	-	18080 18090	"	3.50	
15m	21060		3rd Overtone	3.50	
	21060		Fundamental	4.00	
12m	-	24910	"	4.00	
10m	28060		3rd Overtone	3.50	
	28060		Fundamental	4.00	

Converter and transverter crystals: HC-18/U, 3rd Overtone, Series resonant. 22.0, 24.0, 31.333, 38.6667, 42.0 MHz, £3.50 each. 65.0(HC25) 94.0 MHz 5 O/T £4.00.

SAE please for lists of stock crystals and TTL oscillators for microprocessors, radio crystals, plus Crystal, Monolithic and Ceramic Filters on 455 kHz, 9.0, 10.7 and 21.4 MHz etc.

VAT and UK postage included. Overseas members please add £1.00 per order.

73 G3EDW

Merriott Somerset TA16 5NS England Telephone: (0460) 73718

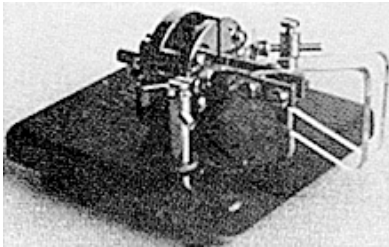

G4ZPY PADDLE KEYS

41 Mill Dam Lane, Burscough, Ormskirk Lancs, L40 7TG. (0704) 894299

BRITAIN'S LEADING MANUFACTURER OF HAND BUILT HIGHLY POLISHED MORSE KEYS
 SEND FOR COLOUR ILLUSTRATED BOCHURE ((4 1/4"x6 1/4" SEA)
 £2 Discount on all keys to members: Quote Number

DC - 80 - 40 - 30 - P TRANSCEIVER KITS

THREE BAND KIT FOR 80m, 40m & 30m £55 ONE BAND KIT (state which) £40

The kit is a 1 to 2 watt CW/RTTY transceiver, with built in audio filtering sidetone and key click filter. The price includes UK postage / packing. Overseas members write for a price quotation. Orders or further details to:

JOHN BEECH, G8SEQ, 124 BELGRAVE ROAD, WYKEN, COVENTRY. CV2 5BH 0203.617367

ENQUIRE ABOUT SIX METRE CONVERTER AND TRANSVERTER PRINTED CIRCUIT BOARDS.

FOR SALE: Standard C58 2m multimode £185, Mutek TVHF 230c 2m to HF band TSVTR (10watts all modes) £225. Would exchange above for QRP rig with cash adjustment. Turn Counters, 115 turn £3. Enamelled copper wire 16 30swg, any length ? Bill, G4WUS. TEL: 0287 42596

DRAGON 32 COMPUTER with RTTY/CW Transceiver ROM pack, RTTY Terminal and CW Transceiver Module. Exchange WHY or sensible offer. Frank, G3YCC. 0482 650410

QRP KITS – QRP PRICES!



DTR3 80m CW TX/RX
 KIT £76.25
 READY BUILT £126.50

CARLTON – 80/40/20m DC Receiver
 Sensitive and selective,
 for SSB and CW. £63.00

TU1 (Mk2) Antenna Tuner £36.80

TU2 (Mk2) ATU with SWR Meter £45.00

Both ATU's are suitable
 for up to 30 Watts (CW).

TUA1 SWR Meter. A very sensitive
 meter (0.5W FSD) for the
 HF bands. £14.50

AF2 An Audio Filter for CW
 with a 6dB bandwidth £11.50
 of just 210 Hz.

ALL PRICES INCLUDE POSTAGE IN GB.
 Surcharge for Overseas – please enquire

LAKE ELECTRONICS specialise in supplying FULLY COMPLETE kits for the
 licensed Amateur and SWL. "COMPLETE" means just that – everything you
 need – right down to the last nut, bolt, washer and bit of wire!

The DTR3 80m Transceiver, for example, comes not only with case and knobs
 but, of course, all the other essentials – a stable VFO which includes a
 good quality variable capacitor and slow-motion drive, RIT (plus and
 minus frequency shift!), sidetone, RX attenuator, 250Hz Audio Filter and
 ready-printed Facias for that "Professional" finish.

With a LAKE ELECTRONICS kit, there is no more wondering how to link up a
 motley collection of various PCB's – or, for that matter, how to fit them
 into a box which, you've now discovered, isn't quite suitable – or
 "making do" with ex junk-box bits that don't quite fit, either physically
 or electrically

As you would expect, a complete set of good quality, brand new,
 components together with comprehensive instructions to guide you every
 step of the way, results in a kit which is not only a pleasure to build
 and use but ensures a finished job you can be proud to show your friends.

For full details of our kits, send SAE to

LAKE ELECTRONICS
7 MIDDLETON CLOSE, NUTHALL
NOTTINGHAM, NG16 1BX
 or, ring Alan, G4D VW, (0602) 382509





HAM RADIO NORTH WEST

Props: Kevin Fox GØ DRK, Mrs. A. Fox

23 NEW COURT DRIVE, EGERTON, BOLTON, LANCS, BL7 9XA

TEL: BOLTON (0204) 54808

CALLERS BY APPOINTMENT PLEASE

RALLY PRICE LIST

Catalogue available 50p – Refundable with first order.

Top Quality British Cables, You Will Not Find Better Anywhere!!

		Post/Pkg
Permanoid URM57 75 OHM Low Loss Coax	60p/M	6p/m
Permanoid URM67 50 OHM Low Loss Coax	65p/M	6p/m
Permanoid URM 50 OHM Coax	23p/M	3p/m
Permanoid URM 75 OHM Coax	30p/M	3p/m
Permanoid RG58/CU 50 OHM Coax	25p/M	3p/m
Permanoid 75 OHM Flat Twin Feeder	18p/M	3p/m
Other Cables		
BOFA (Swedish) 300 OHM Slotted Ribbon GMP6	25p/M	3p/m
POPE H100 (Dutch) 50 OHM Very Low Loss Coax	80p/M	6p/m
TV Coax 75 OHM	20p/M	3p/m
Altronic RG58 per 100 metre Drum	£17.00	£1.50
Equipment and Accessories		
G5RV Multiband Dipole 102ft	£16.25	£2.50
½ G5RV Multiband Dipole 51ft	£14.25	£2.50
HB9 CV 2 El Beam Kit 2m or 70cms	£ 3.95	£2.00
HB9 CV 2 El Beam Kit 6m	£12.95	£2.00
Gamma Twin 2 mtr (Slim Jim Type Ant.)	£ 8.95	£2.00
Pair 7.1Mhz Traps	£ 9.50	£1.00
Dipole Centre (Fully Enclosed)	£ 2.25	50p
Plastic Dogbone Insulators	70p ea	25p
Ceramic Egg Insulators	65p ea	25p
Plastic Egg Insulators	50p ea	25p
50M/165ft PVC Covered Aerial Wire (24 strand copper)	£ 3.00	£1.40
38mm Ferrite Rings	50p ea	25p
High Grade Ferrite Rings (Orange)	60p ea	25p
Sun ½ 2m Antenna (Tilt Base)	£12.95	£2.00
Cast Gutter Mount Black C/W Cable (suitable for above)	£ 9.50	£1.50
Hi-Gain Silver Road CB/10fm Base Antenna	£14.95	£2.00
Revco ½ over ¼ UHF Colinear Mobile Antenna	£ 7.95	£1.50
'AA' Size Ni-Cads – £8.00 per ten	85p ea	25p
Station Log Book (1000QSO)	£ 1.00	25p
Value Component Packs 100's Resistors Mixed	£ 1.00	£1.00
Value Component Packs 100's Capacitors Mixed	£ 1.00	£1.00
G-Comm PSU (British) 8 – 12 amp	£44.25	£2.50
G-Comm PSU (British) 3 – 5 amp	£15.25	£2.00
Universal Ni-Cad Charger	£ 4.95	£1.00

We are now expanding our stock and services!!

e.g. Local Delivery, Bulk Discounts and Special Deals for Clubs etc.

If we haven't got it, we can probably get it, **try us first.**

* WANTED * Your S/H Equipment, HF, VHF Rigs: Cash Paid.

KANGA PRODUCTS

KANGA PRODUCTS offer a range of semi-complete kits for the Amateur. The kits are supplied with all those hard to get bits but leaves out those bits you are likely to have in the junk box.

THE SUDDEN

A small receiver designed by George for the QRP club. Supplied for 80m with full info for the other HF bands. The special QRP price is £13:95

TWO TONE OSCILLATOR

The kit that all constructors should have in the shack, an oscilloscope is a must though to get full use from this unit. SPECIAL QRP PRICE £16:00

MORSE PRACTICE OSCILLATOR

Ideal as an aid to learning CW, but it also acts as a bench AF amp and a Sidetone kit £11:50

DUAL BAND CRYSTAL MIXER

A neat little kit that enables you to build a complete dual band rig using a crystal mixer VFO. SPECIAL G-QRP CLUB PRICE.....£10:00

IAMBIC KEYER KIT

A well designed little kit that will provide full iambic operation with dot - dash memories too all on a small PCB. SPECIAL CLUB PRICE...£15:00

THE OLD 'ONER' TRANSCEIVER

A firm favorite of many ops, still a nice first time QRP rig or for those who think small is beautiful. THE SPECIAL QRP PRICE IS.....£23:00



send a large SAE for
free copy of our
catalogue



KANGA PRODUCTS, 3, LIMES ROAD FOLKESTONE CT19 4AU

TEL: 0303 276171