

# 14

# Transmission Lines

For an antenna to function efficiently it should be installed as high and clear of buildings, telephone lines and power lines as is practically possible. On the other hand, the transmitter that generates the RF power for driving the antenna is usually located in the shack, some distance from the antenna feedpoint. The connecting link between the two is the RF transmission line or feeder. Its sole purpose is to carry RF power from the transmitter to the antenna or received signals from the antenna to the receiver as efficiently as possible.

Any conductor of appreciable length compared with the wavelength will radiate power if it is carrying RF current; in other words it becomes an antenna. The transmission line must be designed so that RF power being carried to the antenna does not radiate.

Radiation loss from transmission lines can be prevented by using two conductors so arranged and operated that the electromagnetic field from one is balanced everywhere by an equal and opposite field from the other. In such a case the resultant field is zero; ie there is no radiation. This is illustrated in Fig 14.1.

## TRANSMISSION LINE BASICS

### Characteristic Impedance

A transmission line with its two conductors in close proximity can be thought of as a series of small inductors and capacitors distributed along its whole length. Each inductance limits the rate at which each immediately following capacitor can be charged when a pulse of electrical power is fed to one end of a transmission line. The effect of the LC chain is to establish a definite relationship between current and the voltage of the pulse. Thus the line has an apparent impedance called its characteristic impedance or surge impedance, whose conventional symbol is  $Z_0$ . Transmission line characteristic impedance is unaffected by the line length. A more detailed description of impedance and transmission lines is described later.

### Velocity Factor

With open wire air-spaced lines the velocity of an electromagnetic wave is very close to that of light. In the presence of dielectrics other than air used in the construction of the transmission line (see below) the velocity is reduced because electromagnetic waves travel more slowly in dielectrics than they do in a vacuum. Because of this the wavelength as measured along the line will depend on the velocity factor that applies in the case of the particular type of line in use. The wavelength in a practical line is always shorter than the wavelength in free space.

### Mismatch and SWR

The feedpoint impedance of an antenna may not be exactly the same as the characteristic impedance of its associated feeder. The antenna is then said to be mismatched to the feeder.

When a wave travelling along a transmission line from the transmitter to the antenna (incident wave) encounters impedance that is not the same as  $Z_0$  (discontinuity) then some of the wave energy is reflected (reflected wave) back towards the transmitter. The ratio of the reflected to incident wave amplitudes is called the reflection coefficient, designated by the Greek letter  $\rho$  (Rho).

$$|\rho| = |Z_L - Z_0 / Z_L + Z_0|$$

Where  $Z_L$  is the load impedance and  $Z_0$  is the characteristic impedance of the transmission line. It follows that the magnitude of  $\rho$  lies between 0 and 1, being 0 for a perfectly matched line.

The reflectometer is an instrument for measuring  $\rho$  and comprises two power meters, one reading incident power and the other reflected power. Power detector directivity is possible because the incident wave voltage and current are in phase and in the reflected wave,  $180^\circ$  out of phase. The construction of a reflectometer meter is described in the test equipment chapter.

Whenever two sinusoidal waves of the same frequency propagate in opposite directions along the same transmission line, as in any system exhibiting reflections, a static interference pattern (standing wave) is formed along the line, as illustrated in Fig 14.2.

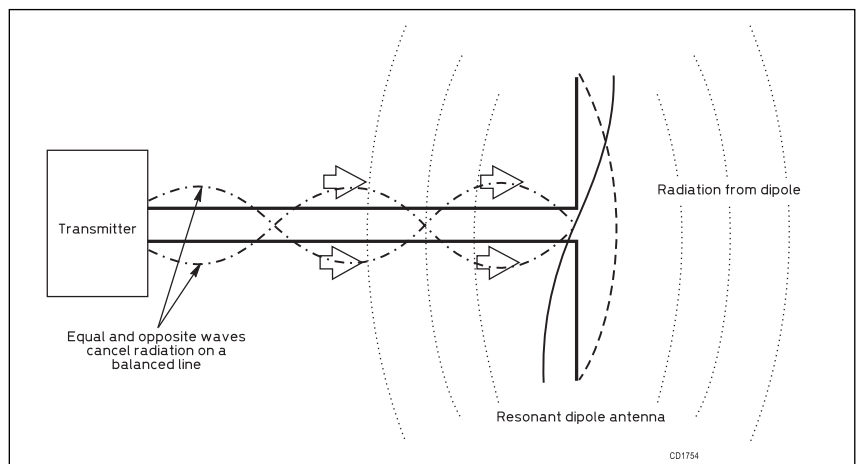

Fig 14.1: RF energy on a transmission line connected to an antenna. No radiation occurs on the line provided the RF energy on each of the lines is equal and opposite. Once the RF energy reaches the antenna there is no opposition to radiation.

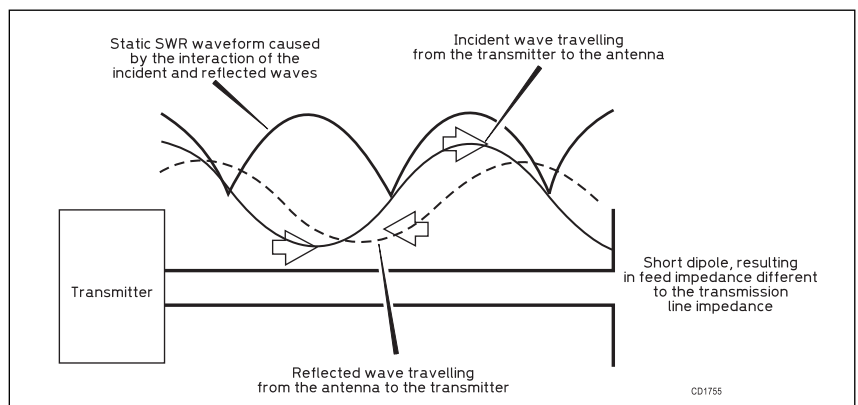

Fig 14.2: Creation of a standing wave on a transmission line.

For the purposes of quantifying reflection magnitude, however, we are interested in the amplitude of the voltage or current nodes and nulls. Standing Wave Ratio (SWR) is defined as the ratio of the voltage or current maximum to the voltage or current minimum along a transmission line, as follows:

$$SWR = V_{max} / V_{min} = I_{max} / I_{min}$$

SWR can be measured using either a current or voltage sensor. The maximum must always be greater than the minimum, thus SWR is always greater than or equal to one. If no reflections exist, no standing wave pattern exists along the line, and the voltage or current values measured at all points along the transmission line are equal. In this case impedance match is perfect, the numerator and denominator of the equation are equal, and SWR equals unity.

As can be seen from Fig 14.2 the direct measurement of SWR must be made at two positions, one quarterwave apart. However, by using the reflectometer the SWR can be measured indirectly as:

$$SWR = 1 + |\rho| / 1 - |\rho|$$

The reflectometer, calibrated in SWR, has become the standard amateur radio tool for measuring transmission line mismatch.

It is often thought that a high SWR causes the transmission line to radiate. This is not true provided the power on each line is equal and opposite as shown in Fig 14.1.

### IMPEDANCE TRANSFORMATION

Impedance can be defined by the ratio of current and voltage. This will be familiar to you when looking at the current and voltage distribution of the standing wave on a dipole antenna as shown in Fig 14.1. The voltage is high and the current zero at the end of the dipole (high impedance) while at the centre of the dipole the voltage is low and the current high (low impedance). The centre is obviously the best place to feed the antenna when using low impedance transmission line.

If the transmission line is terminated with a short circuit, the impedance at that point will be very low as shown in Fig 14.3. It can be seen that the voltage is zero and the current very high at that point. The standing wave pattern shows that this very low impedance is repeated at every half-wave point down the line. On the other hand the impedance will be very high a quarter of a wavelength down the line. This characteristic of transmission lines is often used as an impedance transformer and is used with the G5RV antenna described in the chapter on practical HF antennas.

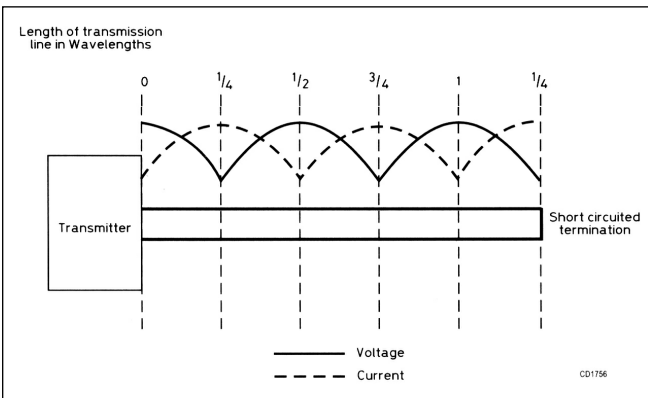

**Fig 14.3: Transmission line terminated with a short showing the patterns of voltage and current SWR. Note that the low impedance caused by the short is reflected at half wavelengths from the short**

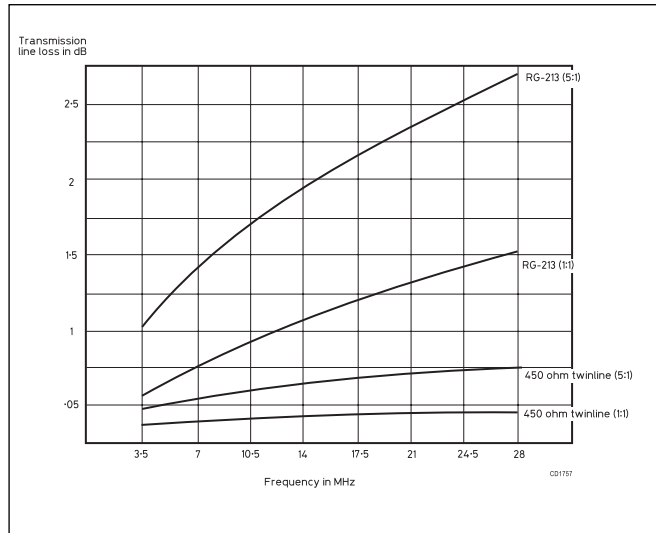

**Fig 14.4: Graph showing losses on a 10m (30ft) of 450-ohm twin-line and RG-213 coaxial cable at an SWR of 1:1 and 5:1**

The impedance transform affect is described later under Smith Chart.

### LOSSES IN TRANSMISSION LINE

Practical transmission line has losses due to the resistance of the conductor and the dielectric between the conductors. As in the case of a two-wire line, power lost in a properly terminated coaxial line is the sum of the effective resistance loss along the length of the cable and the dielectric loss between the two conductors. Of the two losses, the resistance loss is the greater; since it is largely due to the skin effect and the loss (all other conditions remaining the same) will increase directly as the square root of the frequency.

#### Measurement of Coaxial Cable Loss

The classic method of measuring coaxial cable loss is to terminate the cable with a dummy load that is equal to the Zo of the line. Then use a power meter, first at the transmitter end and the load end ensuring that the transmitter power is maintained at a constant level during the test. Then calculate the loss from the difference in power readings using the formula:

$$dB \text{ loss} = 10 \log (P1/P2)$$

where P1 is the power at the transmitter end and P2 is the power at the dummy load.

#### Losses Due to SWR

As described above, a transmission line has losses due to the resistance of the conductor and the dielectric between the conductors. Losses at higher frequencies can also result from a poor quality outer conductor. Fig 14.4 shows approximate losses occur due to antenna/transmission line mismatch (SWR), also shown in Fig 14.4. These losses are for a transmission line over 30m (100ft) long. SWR losses on the HF bands are not as great as is often thought, although at VHF and UHF it is a different matter. As you can see from Fig 14.4, even an SWR of 5:1 on a 30m length of RG-213 coax at 28MHz, the attenuation is only just over 1dB over the perfectly terminated loss.

A reading of SWR due to a mismatch at the transmitter end of the transmission line will be lower than if the measurement were taken at the load (antenna) end. The reason is that the losses on the line attenuate the reflected wave. This means you

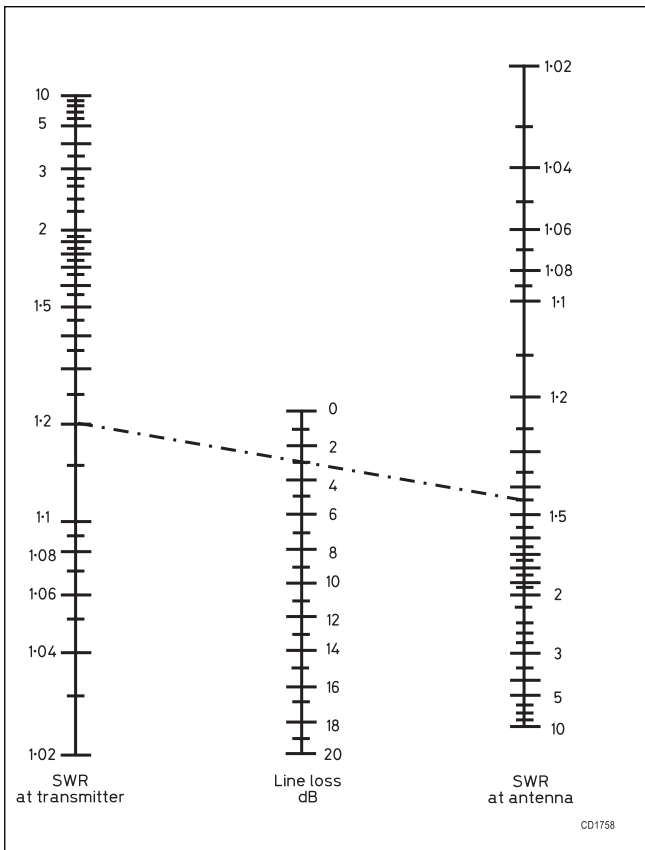
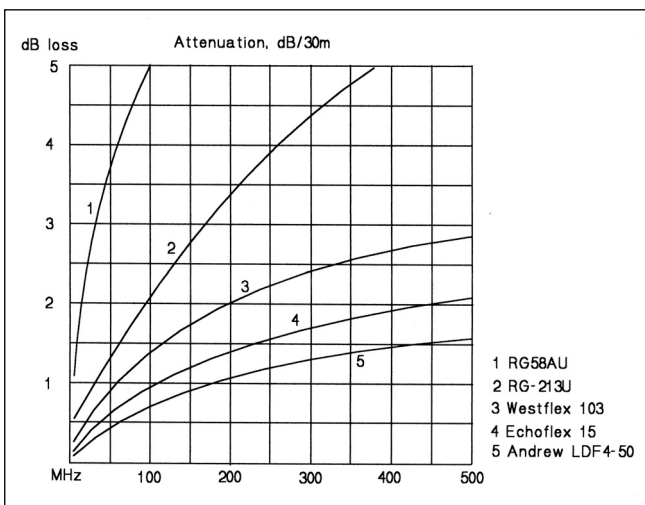

**Fig 14.5: Nomograph for calculating transmission line loss using an SWR meter.**

can use an SWR meter to measure transmission line loss, using the power meter method (use a load that creates a mismatch, say 100Ω) described above. Measure the SWR at the transmitter and at then at the antenna. Use the graph in **Fig 14.5** to determine the cable loss.

**Low-loss Coax - is it Worth It?**

The attenuation factors of various correctly terminated coax cables is shown in **Fig 14.6**. These attenuation figures are for



**Fig 14.6: Attenuation characteristics of various 30m (100ft) lengths of correctly terminated coax cables. With the exception of the thin RG58 coax the attenuation differences of the various cables below 30MHz are not significant**

30m (100ft) lengths and indicate that for frequencies below 30MHz there is not much to be gained by using expensive low-loss coax feeders. The method of construction of these cables to reduce loss is described and illustrated below.

At VHF, and particularly UHF frequencies, it is a different matter. Good quality coax can really enhance a station's performance. On a typical UHF installation at least a 3dB increase should be possible by replacing RG-213 with, say, Ecoflex. If this doesn't sound much remember that generally the size a VHF/UHF antenna array has to be doubled to get 3dB gain.

**TRANSMISSION LINE CONSTRUCTION**

Two types of transmission line have been used to construct antenna systems described in the antenna chapters. These are twin-line feeder and coaxial cable.

**Twin-Line Feeder**

Twin-line feeders can be constructed from two copper wires supported at a fixed distance apart using insulated spacers as shown in **Fig 14.7**. This type of construction is often known as 'open-wire feeder'. Spacers may be made from insulating material, such as plexiglas, polyethylene or plastic. The spacers shown in Fig 14.7 are specifically made for the job. The characteristic impedance of such a line can be calculated with the formula

$$Z_0 = 276 \log_{10} 2S / d$$

Where S is spacing between the wire centres and d is wire diameter.

The construction uses 1.5mm diameter copper wire, and spacers hold the wire around 75mm apart. Using the formula this gives a Z<sub>0</sub> of 550Ω. If 1mm diameter wire had been used, Z<sub>0</sub> would have been close to 600Ω.

The 300Ω twin line (the light coloured line shown in Fig 14.7) is constructed by moulding the conductors along the edges of a ribbon of polyethylene insulation and for this reason is sometimes known as ribbon line. This type of feeder is convenient to use but moisture and dirt tend to change the characteristic of the line.

A further variation of commercial twin-line feeder is 'window-line', which has windows cut in the polythene insulation at regular intervals. This reduces the weight of the line and breaks up the surface area where dirt and moisture can accumulate.

**Coaxial Cable**

Coaxial cable transmission line is used in most amateur installations. The two conductors of the transmission line are arranged coaxially, with the inner conductor supported within the tubular outer by means of a semisolid low-loss dielectric.

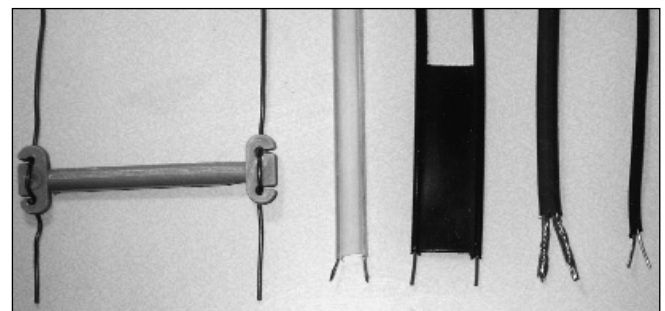

**Fig 14.7: Open wire line constructed using 1mm diameter copper wire and spacers. 300Ω twin line with polyethylene insulation, 450Ω 'window' twin line, 75Ω heavy duty twin line, 75Ω light weight twin line**

The characteristic impedance for concentric circular conductors is given by:

$$Z_0 = (138/\sqrt{\epsilon}) \log_{10} (D/d)$$

Where D is the inside diameter of the outer conductor; d is the diameter of the inner conductor, and  $\epsilon$  is the dielectric constant of the insulator.

Coaxial cable has advantages that make it very practical for efficient operation in the HF and VHF bands. It is a shielded line and has a minimum of radiation loss. Since the line has little radiation loss, nearby metallic objects have minimum effect on the line because the outer conductor serves as a shield for the inner conductor.

Electromagnetic waves tend to propagate along the surface of conductors, rather than inside, due to the phenomenon of skin effect. Coaxial cable performance depends upon the conductivity and size of the outer surface of the inside conductor and the inner surface of the outer conductor.

The centre conductor of a coaxial cable may consist of either a single wire of the desired outer diameter, or from a twisted bundle of smaller strands. Stranded centre conductors improve cable flexibility while solid centre conductors provide the greatest uniformity of outer diameter dimension, which contribute to stable electrical characteristics.

The outer conductor of coax cable ideally should be made from a solid conductive pipe but this construction makes the cable difficult to bend. The flexibility and bend radius of such cables can be improved by corrugating the outer conductor; examples are shown in Fig 14.8.

Nearly all of the popular flexible coaxial cables employ braided outer conductors. These are not as effective electrically as solid outer conductors because gaps in the woven outer conductor permit some signal leakage or radiation from the cable, increasing the attenuation at higher frequencies. This effect can be minimised by adding a layer of copper foil under the braid.

The dielectric material that separates the outer conductor of a coaxial cable from its center conductor determines the intensity of the electrostatic field between conductors and maintains the physical position of the inner conductor within the outer conductor. Common dielectric materials for coaxial cable include polyethylene, polystyrene and PTFE.

The least lossy dielectric material is a pure vacuum, which is totally impractical for use as a cable dielectric. However, the electromagnetic properties of air or gaseous nitrogen are very similar to a vacuum and can be used by mixing low-cost polyethylene with low-loss nitrogen. This is accomplished by bubbling nitrogen gas through molten polyethylene dielectric material before the polyethylene solidifies. This material is variously

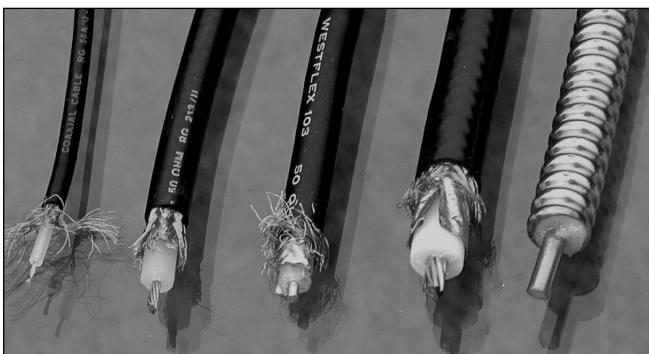

Fig 14.8: Five examples of coaxial cable. From left to right, RG58A/U, 50-ohm RG213/U, Westflex 103 and Andrew LDF4-50 with outer sheath removed

known as cellular polyethylene dielectric, foam dielectric, or poly-foam. It has half the dielectric losses of solid polyethylene at a modest increase in cost.

The characteristic impedance of most coax cable used in amateur radio installations is usually 50-ohms. Other impedance cable is used for impedance transformers and baluns (described later). The impedance of coaxial cable is often printed on the protective vinyl sheath.

In order to preserve the characteristics of the flexible, coaxial line, special coaxial fittings are available. These, and methods of fixing them, are described later.

### THE SMITH CHART

The Smith Chart was invented by Phillip H Smith and described as a Transmission-Line Calculator [1]. While transmission line calculations can be done using a computer with appropriate software such as TLW [2] the Smith chart is described here because it shows very clearly the action of a transmission line as an impedance transformer and the relationship between impedance and SWR .

### The Cartesian Impedance Chart

Impedance comprises resistance and reactance and is always expressed in two parts, R+jX. An impedance having an resistance of 75Ω and a inductive reactance 50Ω is conventionally written as:

$$75 + j50$$

For our consideration of impedance j can simply be regarded as a convention for reactance. The '+j' indicates inductive reactance and a '-j' indicates capacitive reactance. When the antenna is at its resonant frequency the +j and -j parts are equal and opposite so only the resistive part remains.

Impedance can be represented using a chart with Cartesian coordinates as shown in Fig 14.9.

This method of plotting and recording the impedance characteristics of antennas is rather like a Mercator Projection map, with the latitude and longitude of R and jX respectively plotted to define an impedance 'location'. Resonance, where the inductive and capacitive reactances in a tuned circuit or antenna element are equal and opposite, exists only on the zero reactance vertical line.

The impedance chart can be used to plot a series of measurements at various frequencies, which produces an impedance signature of the antenna or antenna system. These measure-

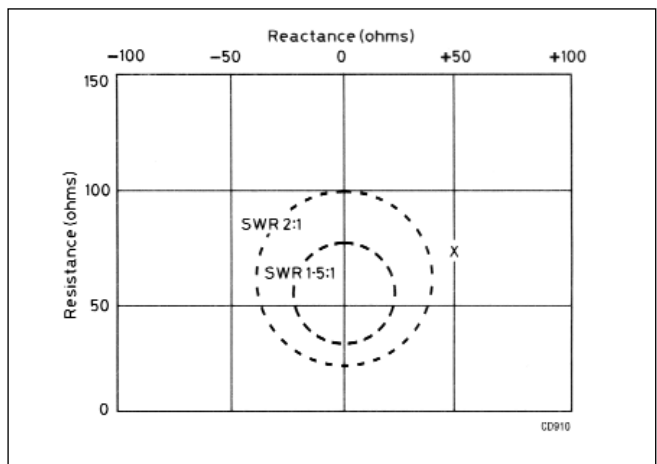

Fig 14.9: Impedance Chart, with X showing an impedance of 75R +50jX. The circles represent SWRs of 1.5:1 and 2:1 respectively for 50-ohm coaxial cable



**Fig 14.10: General Radio 1606 RF impedance bridge. The indicated reactance value is valid for 1MHz and must be divided by frequency to get the true reactance. Inductive or capacitive reactance is established with the use of the switch located between the two dials**

ments are done with an impedance bridge and a professional impedance bridge is shown in **Fig 14.10**. As you can see there are two calibrated controls, one for R and the other for j. Information from the calibrated dials on the instrument can be used to establish the impedance position on the chart when a measurement is made. An impedance noise bridge is described in the test equipment chapter, and other methods of measuring impedance are described in [3].

**The Smith Chart**

The Smith Chart is shown in **Fig 14.11** is an impedance map similar to the ones shown in Fig 14.9. It can be considered as just a different projection, just as maps have different projections, such as the Mercator Projection or the Great Circle projection. The most obvious difference with the Smith chart is that all the co-ordinate lines are sections of a circle instead of being straight. The Smith chart, by convention, has the resistance scale decreasing towards the top. With this projection the SWR circles are concentric, centred on the 50Ω point, which is known as the prime centre.

One of the advantages of the Smith impedance map projection is that it can be used for calculating impedance transforms over a length of coaxial feeder. Because the reflected impedance varies along the feeder it follows that you need to know the electrical length of your coaxial feeder to the antenna. The measured impedance, using an impedance bridge as previously described, is then modified by the impedance transform effect of the length of the feeder.

The impedance transformation Smith Chart is illustrated in **Fig 14.12**. An additional scale is added around the circumference, calibrated in electrical wave-

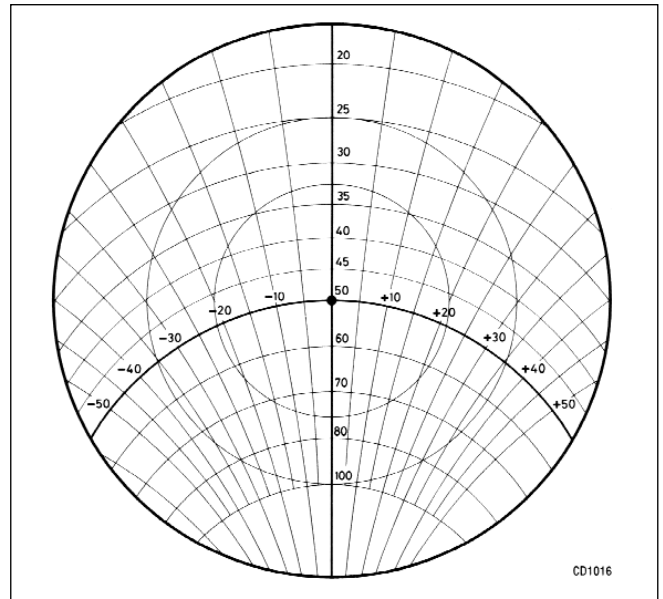

**Fig 14.11: Basic simplified restricted range Smith chart**

length. Halfway round the chart equals 0.25 or quarter wavelength, while a full rotation equals 0.5 or half wavelength.

Two lengths of 50Ω coaxial feeder are shown superimposed around the circumference of a Smith chart; one length quarter wave long and the other 3/8 wavelength). Both lengths are connected to a load having an impedance of 25 +j0. The quarter wave length of line (0.25) gives a measured impedance of 100

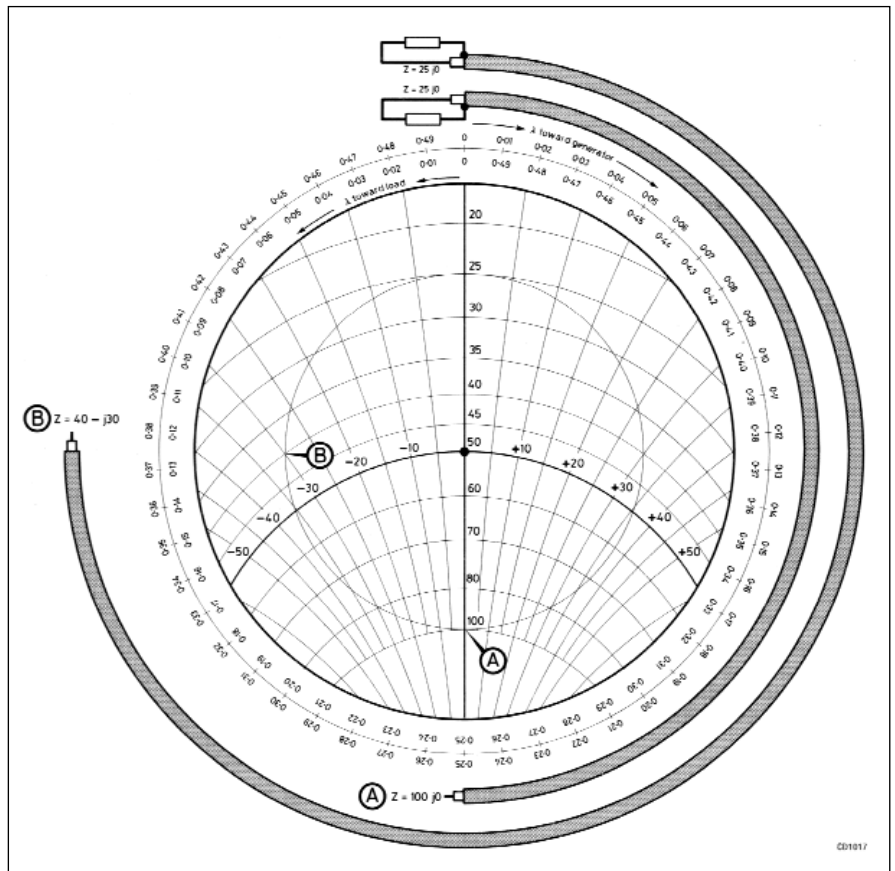

**Fig 14.12: Smith chart, with transmission line electrical length scale, superimposed on two lengths of coaxial cable**

+j0 at the other end while the 3/8 section (0.375) gives an impedance of  $40+j30$ . It can also be seen from Fig 14.12 that a half wave length of coaxial would transform the impedance back to  $25-j0$ .

### A Practical Smith Chart Calculator

You can make a Smith Chart calculator using the charts shown at the end of this chapter. The first one has a prime centre of  $50\Omega$  and a restricted impedance range. This makes it easier to use but the impedance excursions are limited. The other is the standard  $50\Omega$  chart which covers impedances from (theoretically) zero to infinity.

For this exercise we will make an impedance calculator using the restricted range chart as shown in Fig 14.13.

Make a photocopy of the chart (at the end of this chapter), enlarging it if necessary to bring it to a usable size. The chart is then glued to a circular sheet of stiff cardboard or thin aluminium. A small hole is drilled in the chart and backing material at the  $50+j0$  point.

From a piece of very thin perspex or transparent plastic or celluloid cut a circle the same size as the chart to make an overlay. A hole is then drilled exactly at the overlay centre. Identifying the centre point should be no problem if a pair of compasses are used to mark the overlay before cutting.

Make a cursor by drawing a line along the radius of the overlay, using a fine tipped marker pen. Cover the line with a strip of transparent sticky tape to prevent the line rubbing out. Trim off the excess tape.

Fix the transparent overlay to the chart with a nut and bolt, with the tape covered line against the chart. Adjust the nut and bolt so that the overlay can be easily rotated, as shown in Fig 14.13.

The uses to which this calculator can be put are numerous and just three examples are described.

#### Measuring coaxial cable electrical length

It is often important to know the electrical length of transmission line, either for making antenna feedpoint impedance measurements or constructing phasing lines for stacked beams or phased verticals. You can find the electrical length of coaxial cable by physically measuring its length and multiplying it by the cable velocity factor or by using a dip meter.

A more accurate method is to measure the electrical length directly using an RF impedance measuring instrument and the

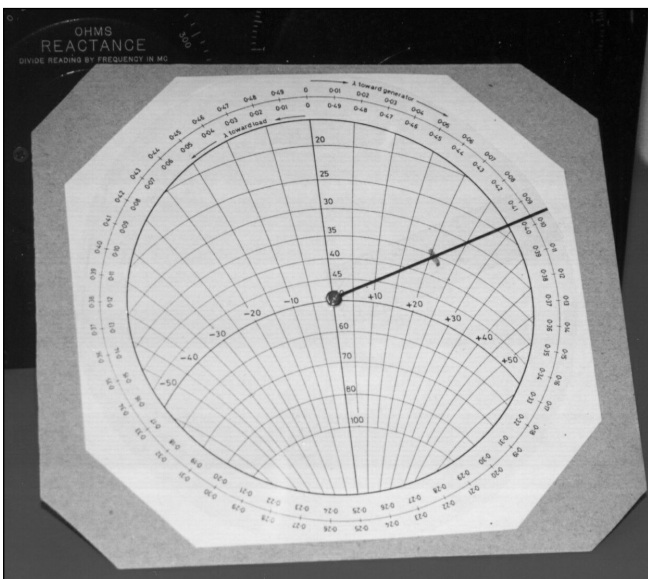

Fig 14.13: General construction of the Smith chart calculator

Smith Chart. It also assumes that the transmission line losses are low; in practice this means that the procedure will only work with relatively short lengths of fairly good quality coaxial cable..

- 1 Terminate the load (antenna) end of the cable with a  $22\Omega$  resistor.
- 2 Measure the impedance at the other end of the feeder.
- 3 Move the cursor so that it intersects the measured impedance point. The cursor will now point to the electrical wavelength of the feeder marked on the outer scale 'wavelengths towards generator'.

The cable may be several half wavelengths and part of a half wavelength long. The Smith chart will only register the part of a half wavelength, which is all we are interested in regarding the impedance transform effect.

#### Calculating antenna impedance from measured impedance

This is a method of calculating antenna impedance from a measured impedance value, using coaxial cable whose electrical length has already been determined.

- 1 Connect the cable to the antenna.
- 2 Measure the impedance at the other end of the coaxial cable.
- 3 Move the cursor over the measured impedance point and mark the point on the overlay with a wax pencil.
- 5 Follow the cursor radially outwards to the scale marked wavelengths towards load. Write this number down.
- 6 Add the length of cable in wavelengths to this number.
- 7 If the number is larger than 0.5, subtract 0.5.
- 8 Rotate the overlay until the cursor points to this number on the wavelengths towards load scale.
- 9 The antenna impedance will be found on the cursor directly under the wax pencil mark.

#### Example:

The measured impedance is  $35+j20$  ohms and the cursor points to 0.407 on the wavelengths towards load scale.

The cable electrical length was measured as 0.13 wavelengths.

Then  $0.407 + 0.13 = 0.537$  wavelengths. Off scale - too big!

Subtract 0.5 wavelengths = 0.037 wavelengths.

Rotate the overlay until the cursor points to 0.037 on the wavelengths towards load scale.

The antenna impedance is shown as  $28-j8$  ohms under the cursor at the same radius as the measured impedance.

#### Calculation of SWR

Calculation of SWR is very simple using the Smith chart. The result is useful for correlating impedance measurements with SWR measurements. To measure SWR:

- 1 Move the cursor over the measured impedance point.
- 2 Mark the point on the overlay with a wax pencil.
- 3 Move the cursor to the 0 point on the outside scales.
- 4 The SWR can be read off as 50 divided by the mark on the cursor. The impedance measured above gives a reading of  $27+j0$ .  $50$  divided by  $27$  equals  $1.85$ ; the SWR in this case is  $1.85:1$ .

You can, of course, calibrate the cursor in SWR. Just place the cursor in the vertical zero position and place marks on the cursor at the 33.3, 25 and 20 resistance points to give SWR marks at  $1.5:1$ ,  $2:1$  and  $2.5:1$  respectively.

#### The Normalized Smith Chart

Most Smith charts are normalised so that they can be used at any impedance and not restricted to  $50\Omega$ , as are the ones so

### ADMITTANCE

The method of calculating the total value of several resistors in series is add their individual values. And the simplest way of calculating resistors in parallel is to add their reciprocals; the answer is also a reciprocal and has to be converted back to R to be in a form which we are more familiar:

$$1/R1 + 1/R2 + 1/R3 = 1/R$$

The reciprocal of R is Conductance (symbol G) and you could work in Conductances if you were dealing with calculations involving lots of parallel circuits.

The reciprocal (or the dual) of Impedance is Admittance (symbol Y).

The reciprocal of reactance is susceptance (symbol B). The unit of conductance, susceptance and admittance is the Siemen.

it is important to know just what it is that your RF bridge is measuring. If the bridge is an Admittance bridge then the result, like the calculation of parallel resistors described above, will need to be converted into the more familiar ohms impedance.

far described. This is achieved by assigning 1 to the prime centre; other values, for example, are 0.5 for 25Ω and 2 for 100Ω in a 50Ω system. Normalization also extends the use of the chart to convert impedance to admittance (see sidebar) and vice versa. A chart for constructing a normalised Smith Chart calculator is also shown at the end of this chapter. The construction of the chart is the same as described above. To use the procedure described below, the cursor must be extended from the centre, ie the cursor line is extended from a radius to a diameter.

#### To convert admittance to impedance:

- 1 Convert the admittance to normalised admittance by multiplying the each component of the admittance value by the prime centre, usually 50.
- 2 Move the cursor over the measured admittance point.
- 3 Mark the point on the overlay with a wax pencil.
- 4 Move the cursor 180 degrees so that the unmarked section of the cursor lies over the measured admittance point.
- 5 The mark on the cursor from 3. gives the normalised impedance reading.
- 6 Convert to actual impedance ohms by multiplying by 50.

### FITTING COAXIAL CONNECTORS

Fitting coaxial connectors to cable is something we all have to do at some time or other.

If you have had trouble in the past fitting connectors, you should find the methods described here by Roger Blackwell, G4PMK [4] helpful. Although specific styles of connector and cable are mentioned, the methods are applicable to many others.

#### Cables and Connectors

The main secret of success is using the right cable with the right connector. If you're buying connectors, it is important to be able to recognise good and bad types, and know what cables the good ones are for. Using the wrong connector and cable combination is sure to lead to problems. Any information you can get, such as that from old catalogues, is likely to prove useful, especially if you can get the cable cutting dimensions and equivalents lists.

Cables commonly are of one of two families, the American 'RG' (RadioGuide MIL specification) types and the English 'UR' (UniRadio) series. RG213 is equivalent to URM67, is 10.5mm in diameter and is the most common cable used with type N and PL259 connectors.

RG58 (5mm OD) is one usually used with BNC connectors, although these also fit cable URM43 since both have similar dimensions. If there is any doubt about the quality of the cable, have a look at the braid. It should cover the inner completely. If it doesn't it is unlikely to be worth buying. There are a lot of so-called 'RG8' cables about these days, intended for the cheap end of the CB market, and should be avoided - RG8 is an obsolete designation - the modern equivalent is RG213 or URM67.

The three most popular connector types are the UHF, BNC and N ranges. These will be covered in some detail, a few others mentioned later. If you can, buy connectors from a reputable manufacturer. There are some good surplus bargains about, so a trawl through the boxes at the local rally may prove worthwhile. The PL259 UHF connector is no good much beyond 200MHz, because the impedance through the plug-socket junction is not 50Ω. The suitability of N and BNC connectors for use at UHF and beyond is due to their maintaining the system impedance (50Ω) through the connector. PL259 plugs, like the RG8 cable they were intended for, have a lot of nasty imitations. Beware of any that don't have PTFE insulation. The plating should be good quality and there should be two or more solder holes in the body for soldering to the braid. There should be two small tangs on the outer mating edge of the plug, which locate in the serrated ring of the socket and stop the body rotating. If you are going to use small-diameter cable with these plugs, get the correct reducer. It is advisable to buy the reducers at the same time as buying the plugs because some manufacturers use different reducer threads.

With BNC, TNC (like the BNC but threaded) N and C (like N but bayonet) types, life can be more complicated. All these connectors are available in 50 and 75Ω versions. Be sure you get the right one! All of these connectors have evolved over the years, and consequently you will meet a number of different types. The variations are mostly to do with the cable clamping and centre pin securing method.

If you are buying new connectors, then for normal use go for the pressure-sleeve type, which is much easier to fit.

All original clamp types use a free centre pin that is held in place by its solder joint onto the inner conductor. Captive contact types have a two-part centre insulator between which fits the shoulder on the centre pin. Improved MIL clamp types may have either free or captive contacts. Pressure sleeve types have a captive centre pin. As an aid to identification, Fig 14.14 shows these types. Pressure clamp captive pin types are easy to spot; they have a ferrule or 'top hat' that assists in terminating the braid, a two-piece insulator and a centre pin with a shoulder. Unimproved clamp types have a washer, a plain gasket, a cone-ended braid clamp and a single insulator, often fixing inside the body. Improved types have a washer, a thin ring gasket with a V-groove and usually a conical braid clamp with more of a shoulder. There are variations, so if you can get the catalogue description it helps!

#### Tools for the Job

To tackle this successfully, you really need a few special tools. While they may not be absolutely essential, they certainly help. Most of them you probably have anyway, so it's just a matter of sorting through the toolbox. First and foremost is a good soldering iron. If you never intend to use a PL259, a small instrument type iron is sufficient. If you use PL259s, or intend to use some

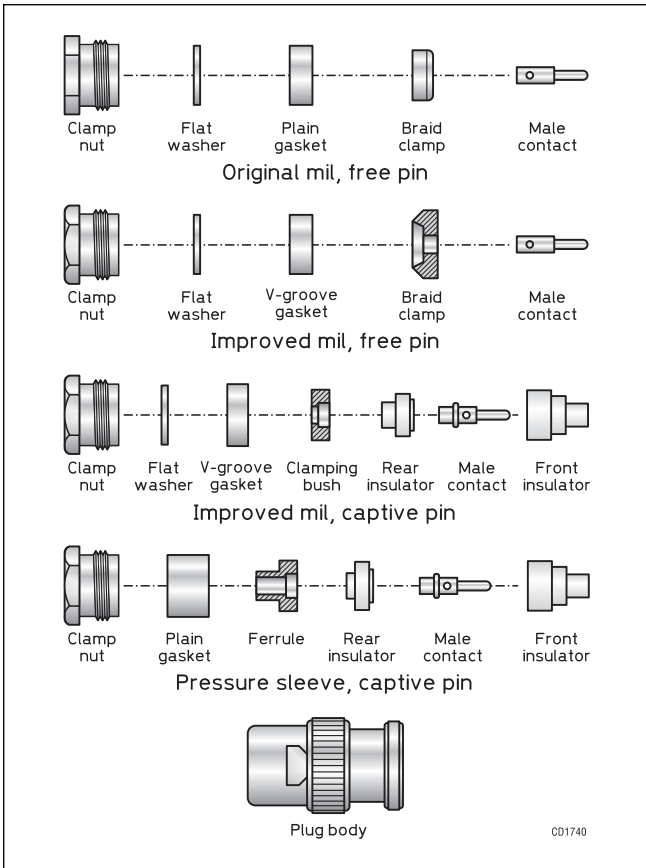

Fig 14.14: Types of BNC/N cable clamps

of the 'dirty tricks' described later, something with a lot more heat output is required. Ideally a thermostatically-controlled iron is best; as with most tools a little extra spent repays itself handsomely in the future.

A sharp knife is another must. A Stanley-type is essential for larger cables, provided that the blade is sharp. For smaller cables, you can use a craft knife or a very sharp penknife. Use sharp blades, cut away from you, and keep the object you're cutting on the bench, not in your hand. Although sharp, the steel blades are brittle and will shatter if you apply excessive force or bend them, with bits of sharp blade shooting all over the place. Dispose of used blades in a box or plastic jar. Model shops have a good range of craft knives, which will also do an excellent job. A pair of small sharp scissors is needed for cutting braids, and a blunt darning needle (mounted in a handle made from a piece of wood dowelling) is useful for unweaving the braid. A scriber is also useful for this job. You will find a small vice a great help as well. For BNC, TNC and N type connectors, some spanners are essential to tighten the gland nuts. The BNC/TNC spanners should be thin 7/16in AF. Those for type N need to be 11/16 x 5/8 AF. A junior hacksaw is needed to cut larger cables. Finally, if you intend to put heatshrink sleeves over the ends of plugs for outdoor use, some form of heat gun helps, although the shaft of a soldering iron may work. (A hot-air paint stripper can be used for this purpose - with care).

### Preparing Cables

Fitting a plug requires you to remove various bits of outer sheath, braid and inner dielectric. The important knack to acquire is that of removing one at a time, without damaging what lies underneath. To remove the outer sheath, use a sharp knife or scalpel. Place the knife across the cable and rotate the

cable while applying gentle pressure. The object of doing this is to score right round the cable sheath. Now score a line from the ring you just made up to the cable end. If you have cut it just enough, it should be possible to peel away the outer sheath leaving braid intact underneath. If this is not something you've tried before, practice on a piece of cable first. For some connectors, it is important that this edge of the sheath is a smooth edge at right angles to the cable, so it really is worth getting right.

Braid removal usually just requires a bit of combing out and a pair of scissors. Removal of the inner dielectric is most difficult with large-diameter cables. Again, it is important that the end is a clean, smooth cut at right angles to the cable. This is best achieved by removing the bulk of the dielectric first, if necessary in several stages. Finally the dielectric is trimmed to length. There is a limit to how much dielectric you can remove at one go; 1-2cm is about as much as can be attempted with the larger sizes without damaging the lay of the inner. For the larger cables, it is worthwhile to pare down the bulk of the unwanted material before trying to pull the remainder off the inner. If you can, fit one plug on short cables before you cut the cable to length (or off the reel if you are so lucky). This will help to prevent the inner sliding about when you are stripping the inner dielectric.

### Fitting PL259 Plugs

#### Without reducer, RG213 type cable

First, make a clean end. For this large cable, the only satisfactory way is to use a junior hacksaw. Chopping with cutters or a knife just spoils the whole thing. Having got a clean end, refer to Fig 14.15 for the stripping dimensions. First, remove the sheath braid and dielectric, revealing the length of inner conductor required. Do this by cutting right through the sheath and braid, scoring the dielectric, then removing the dielectric afterwards. Next carefully remove the sheath back to the dimension indicated, without disturbing the braid. Examine the braid; it should be shiny and smooth. If you have disturbed it, or it looks tarnished, start again a little further down.

With a hot iron, tin the braid carefully. The idea is to do it with as little solder as possible; a trace of a non-corrosive flux such as Fluxite helps. Lightly tin the inner conductor also at this stage. Now slide the coupling piece onto the cable (threaded end towards the free end). Examine the plug body. If it isn't silver-

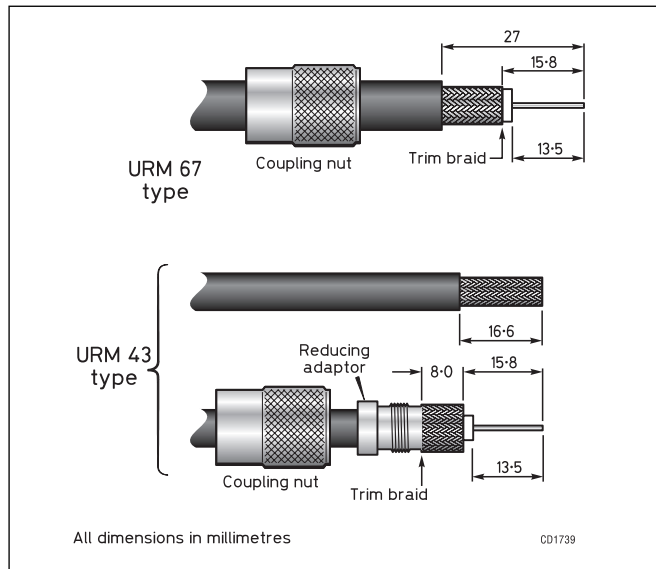

Fig 14.15: PL259 plug assembly



plated, and you think it might not solder easily, apply a file around and through the solder holes. Now screw the body onto the cable, hard. When you've finished, the sheath should have gone into the threaded end of the connector, the inner should be poking out through the hollow pin, and the end of the exposed dielectric should be hard up against the inside shoulder of the plug. Look at the braid through the solder holes. It should not have broken up into a mass of strands; that's why it was tinned. If it has, then it is best to start again.

If all is well, lightly clamp the cable in the vice, and then apply the iron to the solder holes. Heat it up and then add solder. It should flow into the holes; if it stays there as a sullen blob, the body isn't hot enough. Now leave it undisturbed to cool before soldering the inner by heating the pin and feeding solder down the inner. Finally, when its all cool, cut any excess protruding inner conductor and file flush with the pin, then screw down the coupling ring. Merely as a confidence check, of course, test for continuity on both inner and outer from one end of the cable to the other, and check that the inner isn't shortened to the braid.

### With reducer, RG58 type cable

First, slide the outer coupler and the reducer on to the cable. Next, referring to Fig 14.15, remove the outer sheath without nicking the braid. Now, using a blunt needle, gently unweave the braid a bit at a time until it is all straight and sticking out like a ruff around the cable. Remove the inner dielectric, without nicking the inner conductor; so as to leave the specified amount of dielectric. Tin the inner conductor. Bring up the reducer until the end of the reducer is flush with the end of the outer sheath. Fold the braid back so it lies evenly over the shank of the reducer, then cut off the excess braid with scissors so that it is not in danger of getting trapped in the threads. Smooth it down once more, then offer up the plug body and, while holding the reducer and cable still, screw on the plug body until it is fully home. The only really good way of doing this is with two pairs of pliers. Now hold the assembly in the vice and ready the soldering iron.

There has been a spirited discussion from time to time about the advisability of soldering the braid through the holes. Professional engineers use soldered connections or compression types but see "dirty tricks" later.

### Fitting BNC and Type N plugs

These are 'constant impedance' connectors; that is, when correctly made up, the system impedance of 50Ω is maintained right through the connector. It is vital that the cable fits the connector correctly, therefore check that each part fits the cable properly after you prepare it. Refer to Fig 14.16 for BNC dimensions, and Fig 14.17 for N types.

#### Original or unmodified clamp types

Slide the nut, washer and gasket onto the cable in that order. With the sharp knife, score through the outer sheath by holding the knife and rotating the cable, without nicking the braid. Run the knife along the cable from the score to the end, and then peel off the outer sheath.

Using a blunt needle, for example, start to unweave the braid enough to enable the correct length of dielectric to be removed. Now slip the braid clamp on, pushing it firmly down to the end of the outer sheath. Finish unweaving the braid, comb it smooth then trim it with scissors so that it just comes back to the end of the conical section of the clamp. Be sure that the braid wires aren't twisted.

Now fit the inner pin and make sure that the open end of the pin will fit up against the dielectric. Take the pin off and lightly tin the exposed inner conductor. Re-fit the pin and solder it in place by placing the soldering iron bit (tinned but with the solder

wiped off) on the side of the pin opposite the solder hole. Feed a small quantity of solder (22SWG or so works best) into the hole. Allow the connector to cool and then examine it. If you've been careful enough, the dielectric should not have melted. Usually it does, and swells up, so with the sharp knife trim it back to size. This is essential, as otherwise the plug will not assemble properly. Remove any excess solder from around the pin with a fine file. Now push the gasket and washer up against the clamp nut, check the braid dressing on the clamp, and then push the assembly into the plug body. Gently firm home the gasket with a small screwdriver or rod and then start the clamp nut by hand. Tighten the clamp nut by a spanner, using a second spanner to hold the plug body still; it must not rotate. Finally, check the completed job with the shack ohmmeter.

#### Modified or improved clamp types

In general, this is similar to the technique for unmodified clamp types described above. There are some important differences, however. The gasket has a V-shaped groove in it, which must face the cable clamp. The clamp has a corresponding V-shaped

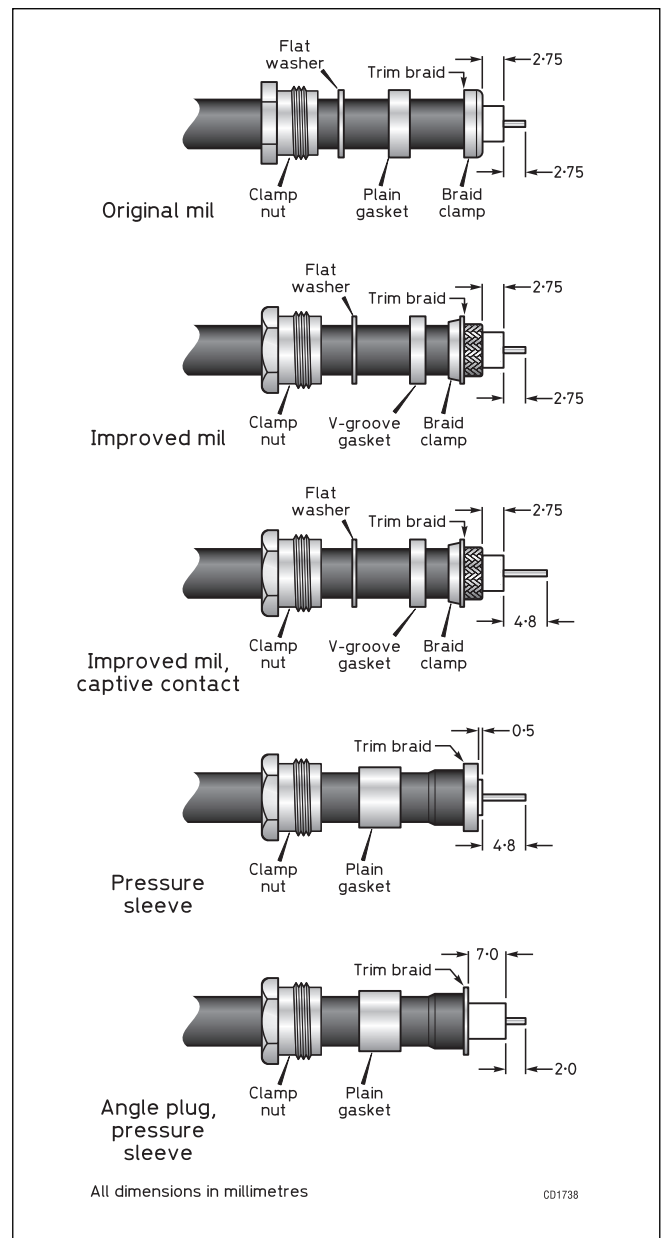

Fig 14.16: BNC dimensions, plugs and line sockets

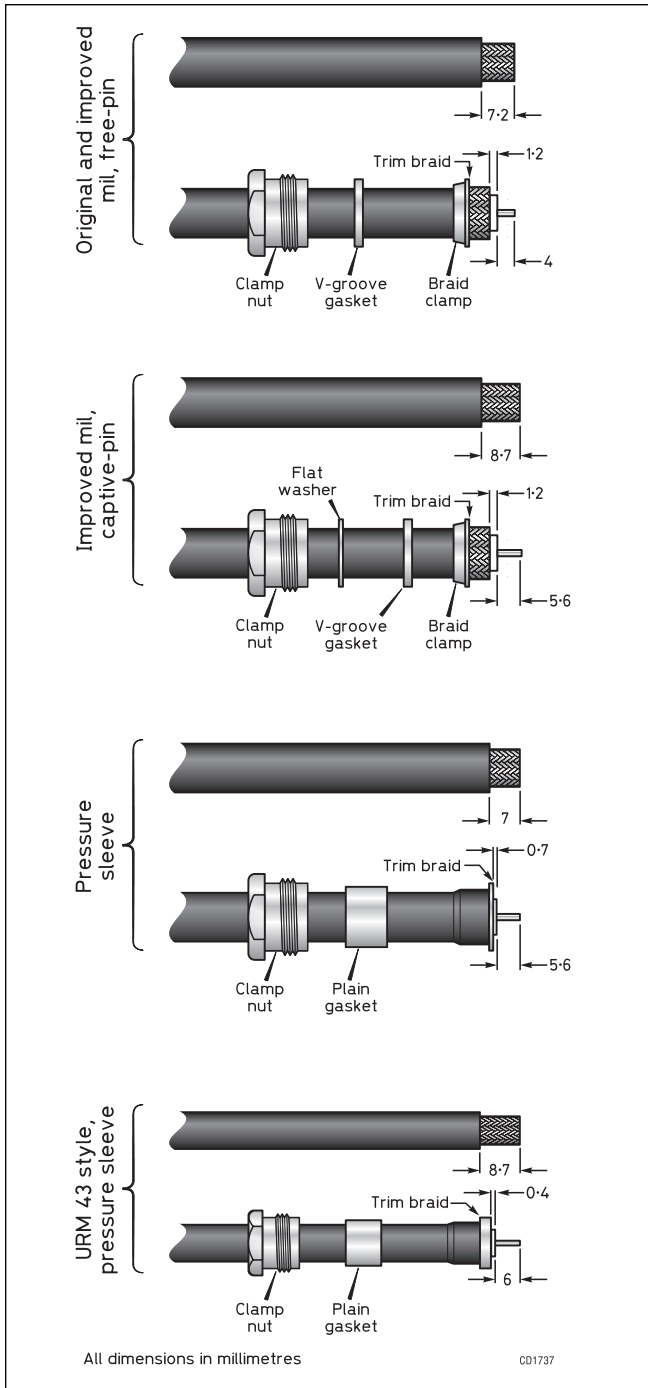

Fig 14.17: N-type dimensions, plugs, angle plugs and line sockets

profile on one side; the other side may be conical or straight sided, depending on the manufacturer. If the clamp end has straight sides, the braid is fanned out and cut to the edge of the clamp only, not pushed down the sides. Some types have a small PTFE insulator, which is fitted before the pin is put on (common on plugs for the small RG174 cable). You now appreciate why having the assembly instructions for your particular flavour of plug is a good idea! Still, by using these instructions as a guide, it shouldn't be too difficult to get it right, even if it does not fit the first time. One important point - if the plug has been assembled correctly and tightened up properly, the clamp will have (intentionally) cut the gasket, which is then rather difficult to re-use. This thin gasket will not stand a second attempt. The thicker gasket types will often allow careful re-use.

**Captive contact types**

These have a small shoulder on the pin, and a rear insulator, which fits between the pin and the cable. Most types use a thick gasket and a ferrule, although some use a V-grooved braid clamp and thin gasket. The ferrule type is described first because these are the most commonly available, and the easiest to fit.

First, slip the nut and gasket on to the cable. Refer to Figs 14.16 or 14.17 for cutting dimensions then strip off the correct amount of outer sheath by rotating the cable, producing a neat scored circle. Score back to the end of the cable and peel off the unwanted sheath. Comb out the braid, and with it fanned out evenly around the cable, slide the ferrule (small end first) on to the dielectric-covered inner conductor.

Push it home so that the narrow portion of the ferrule slides under the outer sheath, and the end of the outer sheath rests against the ferrule shoulder. Trim the braid with scissors to the edge of the ferrule.

Slide up the gasket so that it rests gently against the ferrule shoulder, which will prevent the braid from being disturbed. Using the sharp knife, trim the dielectric back to the indicated dimension, without nicking the inner conductor. Fit the rear insulator, which will have a recess on one side to accommodate the protruding dielectric. Incidentally, if you don't have the size for your particular plug, trim the dielectric until it fits; but don't over-do it!

Now trim the exposed inner conductor to length and check by fitting the pin, whose shoulder should rest on the rear insulator unless the inner has been cut too long. Tin the inner lightly, then fit the pin and solder it by applying the iron tip (cleaned of excess solder) to the side of the pin opposite from the solder hole and feed a small amount of solder into the hole.

Allow to cool, and then remove the excess solder with a fine file. Now fit the front insulator (usually separate from the body) and push the whole assembly into the body. Push down the gasket gently into the plug body with a small rod or screwdriver. Start the nut by hand, and then tighten fully with one spanner, using the other to prevent the body from rotating. Check with the ohmmeter, then start on the other end - remember to put the nut and gasket on first!

**Variations**

Angle plugs generally follow a similar pattern to the straight types, except that connection to the inner is via a slotted pin, accessed via a removable cap screw. Tighten the connector nut before soldering the inner. Line sockets are fitted in the same way as plugs.

Interestingly, many connectors used on high-grade low loss cables appear to be solderless. This applies to the N-type male and female connectors used with Ecoflex15, see Fig 14.18. This connector proved to be very easy to fit.



Fig 14.18: Partially assembled N-conductor used with Ecoflex 15 coax. Note that the centre pin is a tight push fit over the coax centre conductor

## Dirty Tricks

We would like to use new connectors every time, but often a pressure sleeve type can be reused if the gasket is not too deformed. Get all the solder you can out of the pin and then carefully ream out the rest with a small drill, held in a pin chuck. Tarnished silver-plated connectors can be made to shine by dipping the metal parts in Goddards 'Silver Dip' silver cleaner, or a solution of photographic fixer. Rinse carefully afterwards, then bake in a slow oven.

BNC connectors for URM67 cable can be rather hard to find. A standard captive contact BNC plug can be fitted to URM67 in the following way. First, discard the nut, gasket and ferrule, and prepare the rear insulator by removing the ridge from it with a sharp knife. Now prepare the cable by cutting with a knife, right through the jacket, braid and insulator about 5mm back from the end. Cut sufficiently deep so that you notch the inner conductor strands, and remove the remains. Carefully bend the six individual outer strands of the inner so they break off flush with the end of the dielectric, leaving one straight inner strand. Now remove sufficient outer jacket (about 2cm) such that when the body is pushed on the cable, some braid is still visible. Tin the braid and inner conductor lightly, then fit the rear insulator, pin and front insulator and push home the assembly into the plug body. With the big iron, heat the plug body and feed solder down the joint with the braid. After it has cooled, put some heatshrink adhesive lined sleeving over the plug and cable joint to protect it. This arrangement is almost as good as the real plug, and certainly better than an adapter; it will happily stand 100W of 1,296MHz.

An N-plug can be carefully pushed on to a BNC socket; OK for quick test equipment lash-ups, but don't do it too often or too hard as you will eventually damage the socket.

If the braid is soldered to the plug it can sometimes be difficult to judge the quality of the soldered joint. Too much heat can cause damage to the cable or the insulation of the plug while too little heat will cause a dry joint. Some amateurs avoid soldering by folding the braid down the outside of the sheath of the cable and screwing the cable entry of the plug body over it.

The most common cause of connector failure is a poor soldered joint or corrosion. If the connector is used outside the connector can be packed with any non-conducting grease, which prevents ingress of water to the connector and the coax and is very effective in eliminating corrosion.

## SPLICING COAXIAL CABLE

The radio engineer's method of joining two lengths of coax together is to use coaxial connectors. However, in the description of coax cable splicing by G3SEK [5] that follows, you will see that a splice can be made entirely without connectors. A splice in coaxial cable needs to be as close as possible to an uninterrupted run of cable. In practice this requires four things:

- Constant impedance through the splice.
- As short an electrical length as possible, if it is not possible to make the impedance quite constant.
- Continuous shield coverage.
- Good mechanical properties: strong and waterproof.

At low frequencies coax can be spliced with a two-pole connector block as shown in **Fig 14.19(a)**. Tape over the joint and it's done. Even though this creates a non-constant impedance, the electrical length of the splice is so short that it's most unlikely to have any significant effect. The main drawback is that the break in the shield cover provides an opportunity for RF currents to flow out from the inside of the shield and onto the outer sur-

**Fig 14.19:**  
**Methods of**  
**splicing coaxial cable**

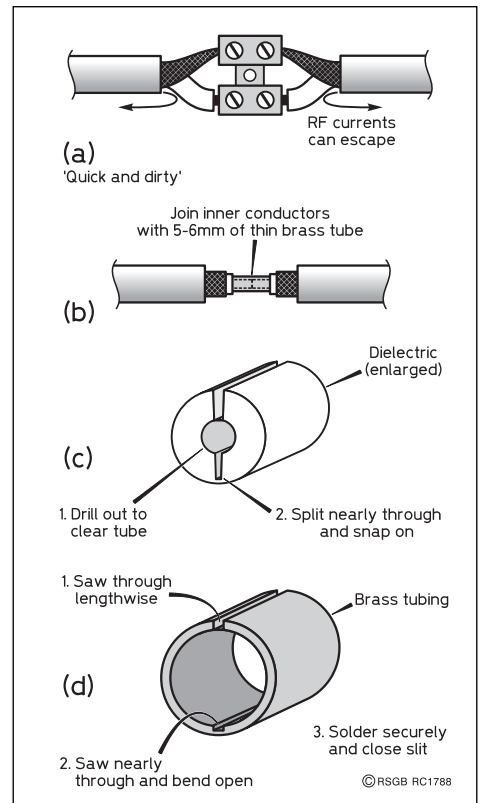

face (the skin effect makes RF currents flow only on surfaces). This may undo all your good efforts to keep RF currents off the feedline, using baluns or feedline chokes.

For a truly coaxial splice you need to join and insulate the inner conductor, and then replace the outer shield. Avoid making a big blob of twisted inner conductors and solder if you can, because that will create an impedance bump - a short section of line with a different impedance from the coax itself.

The neatest and electrically the best way to join the inner conductors is to use a 5-6mm (¼in) sleeve of thin brass tubing, see **Fig 14.19(b)**. This is available from good hobby shops in sizes from 1.6mm (1/16in) outside diameter up to 12.7mm (½in), in steps of 0.8mm (1/32in); these sizes telescope together, by the way. To replace the dielectric, take a piece of the original insulation, drill out the centre to fit over the sleeve, and split it lengthways so that it snaps over the top, see **Fig 14.19(c)**. To complete the shield on braided coax, one good way is to push the braid away from each end while you join the inner conductor, and then pull it back over the splice. Solder the braid quickly and carefully to avoid melting the dielectric underneath. For mechanical strength you can tape a rigid 'splint' alongside the joint as you waterproof it.

Alternatively the splice can be made using a very short length of air-insulated line of the same characteristic impedance. The inner conductor is joined using tubing as already described in **Fig 14.19(b)**. The outer is made from a short length of brass or copper tubing.

The outer tube is 'hinged' to fit over the joint as shown in **Fig 14.19(d)** shows how to then solder the whole thing up solidly. This method makes a very strong splice with excellent RF properties.

For 50-ohm air-spaced coax, the ratio of the inner to outer conductor diameters is 0.43, so all you need to do is to choose the right diameters of tubing for the inner and outer conductors. Remember that the relevant dimensions are the outside diameter of the inner conductor, and the inside diameter of the outer

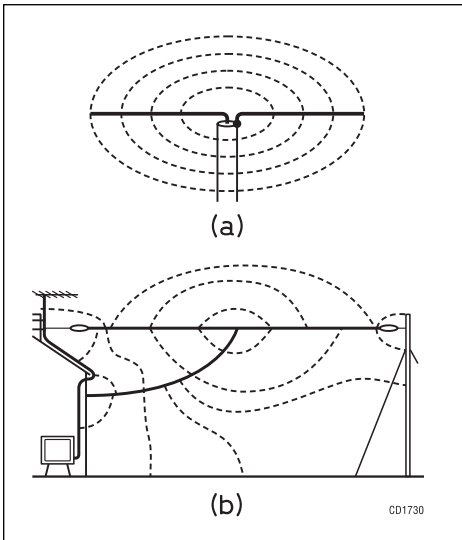

**Fig 14.20:** (a) Idealised picture of electric fields around a coaxial dipole. (b) The typical reality

conductor. It so happens that air-spaced line needs a larger inner diameter than solid-dielectric, semi-air spaced or foamed line, which conveniently accommodates the wall thickness of the inner sleeve. For UR67, RG213 and RG214, the best available choices are 8mm (5/16in) and 4mm (5/32in) outside diameters.

These coaxial splices will be at least as good as a splice using coaxial connectors.

### A QUESTION OF BALANCE

Real-life antennas are nothing like the textbook pictures. [6] The textbooks show us a simple dipole; fed in the centre, with electric field lines neatly connecting the opposite halves, and lines of magnetic flux looping around the wires. Fig 14.20(a) is a typical version of this pretty picture, showing only the electric field lines for clarity. Everything is symmetrical, and the system is said to be 'balanced' with respect to ground.

The reality of a typical installation is very different. As Fig 14.20(b) shows, the electric field lines connect not only with the opposite half of the dipole, but also with the feedline, the ground, and any other objects nearby. The magnetic field may be less disturbed, but the overall picture is in no way symmetrical! Although the electromagnetic coupling between the opposite halves of a horizontal dipole makes the antenna 'want' to be balanced, the

coupling has to compete with the distorting effects of the asymmetrical surroundings. As a result, practical antennas can be very susceptible to the way they are installed, and are hardly ever well balanced.

Contrast the messy environment of the antenna with the tidy situation inside a coaxial cable shown in Fig 14.21. The currents on the centre core (I1) and the inside of the shield (I2) are equal and opposite, ie 180° out of phase. The two conductors are closely coupled along their entire length, so the equal and antiphase current relationship is strongly enforced. Also, what goes on inside the cable is totally independent of the situation outside. Thanks to the skin effect, which causes HF currents to flow only close to the surfaces of conductors, the inner and outer surfaces of the coaxial shield behave as two entirely independent conductors. You can hang the cable in the air, tape it to a tower or even bury it, yet the voltages and currents inside the cable remain exactly the same. About the only things you can do wrong with coax cable are to let water inside, or bend it so sharply that it kinks. That's why coax is popular - it is so easy to use.

The problems arise when you connect a coaxial cable to an antenna. If the antenna is in any way unbalanced - which it will be in any practical situation - a difference will appear between the currents flowing in the antenna at either side of the feed-point.

This difference current is shown in Fig 14.22 as I3, and is equal to (I1-I2). The current I3 has to flow somewhere. It cannot flow down the inside of the cable because I1 and I2 must be equal, so instead it flows down the outside of the outer sheath. As a result, the feedline becomes part of the radiating antenna. This causes distortion of the radiation pattern, RF currents on metal masts and Yagi booms, and problems with 'RF in the shack'. Even worse can be RF currents flowing in the mains and on TV cables, leading to all manner of EMC problems.

### Baluns

The word balun is short for 'balanced to unbalanced'. A balun is a device, which somehow connects a balanced load to an unbalanced coaxial line. It aims to prevent I3 from flowing, by placing a large series impedance on the outside of the feedline. As a result, the antenna currents can only flow on the inside of the feedline, and the properties of the coaxial cable force the antenna currents at either side of the feed point to be equal and in antiphase, ie balanced. Choke off the difference current, and the antenna currents must adjust themselves to become more symmetrical. By using an appropriate type of balun at the antenna feedpoint, you can effectively prevent stray surface currents on the feedline. As a result, the current distribution on the antenna will adjust itself to become more symmetrical, so the antenna will work better and many of your EMC problems may also disappear.

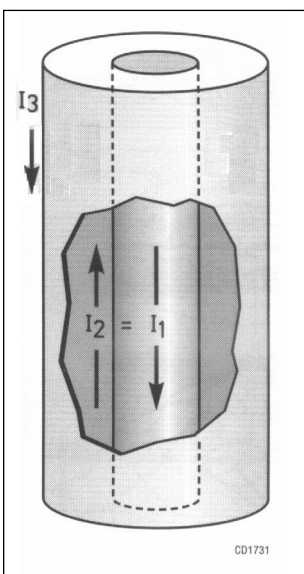

**Fig 14.21:** Currents on the inside of a coaxial cable (I1 and I2) are always equal and in antiphase. The skin effect allows a separate current I3 to flow on the outside

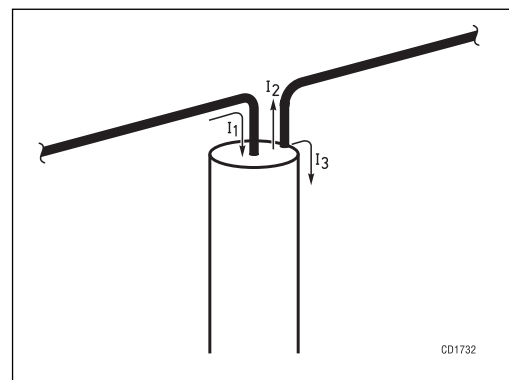

**Fig 14.22:** If the antenna currents on either side of the feed-point are unequal, the difference I3 = I1 - I2 will flow down the outside of the cable

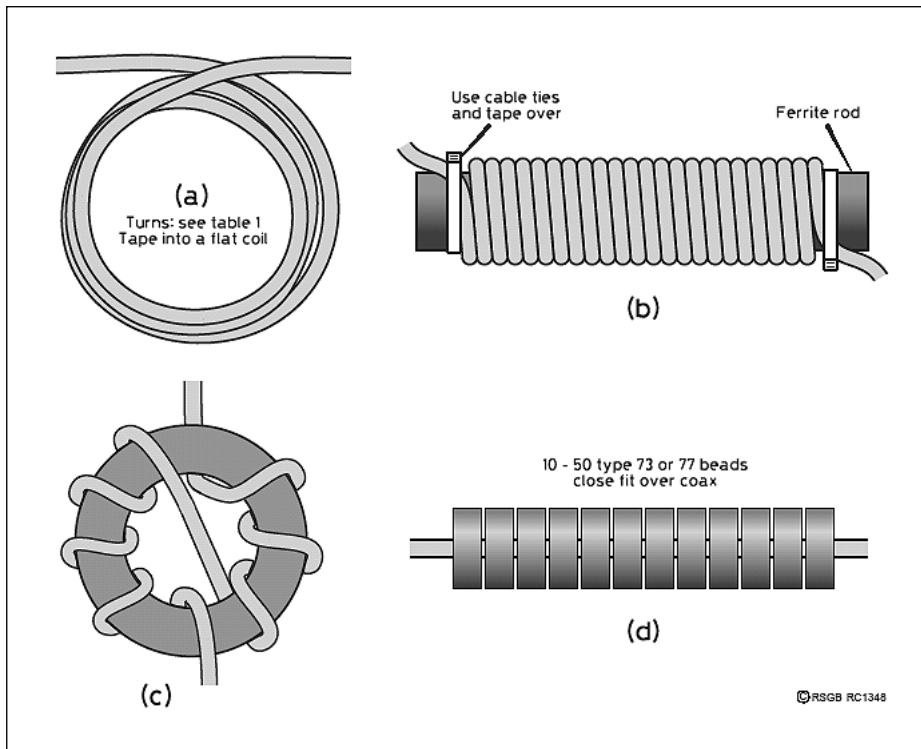

**Fig 14.23: Four varieties of choke-type balun. (a) Coil of coaxial cable (typically 6-10 turns - only three turns shown). (b) Coaxial cable on toroid. (c) Coaxial cable on ferrite rod. (d) Ferrite sleeve. These chokes are designed to present a high impedance to unwanted currents on the outside of the coax cable**

**Choke or current baluns**

The simplest baluns are the ones that prevent surface currents from flowing, by forming the coaxial cable into an RF choke at the antenna feed point (the currents flowing inside the cable are quite unaware that the cable has been coiled up.) At its very simplest, a choke balun can be just a few turns of cable in a loop of diameter 150 to 300mm (6in to 12in), see Fig 14.23(a), and in some circumstances this may be all you need. See Table 14.1 for the number of turns required. Alternatives are to wind the cable around a toroid or a ferrite rod, see Fig 14.23(b) and (c). Yet another alternative popularised by W2DU is to feed the cable through ferrite tubes or beads to form a sleeve as shown in Fig 14.23(d); this is generally lighter and more compact than a coiled choke, but somewhat more expensive. Ideally the cable should be a close fit inside the ferrite sleeve, and this may not be easy to achieve with readily available materials.

The power rating of any choke balun is essentially that of the cable itself. Even if magnetic material is involved, the main feeder currents cancel inside the cable, leaving only the small residual surface current to magnetise the core.

Although choke baluns will prevent surface currents from flowing at the feedpoint itself, electromagnetic coupling between the antenna and points further down the feedline may induce surface currents, which the balun cannot prevent. This will happen if the installation is asymmetrical.

Induced currents become much greater if the feedline length is resonant, producing greater RF voltages on the line and on the equipment in the shack. The resonant length has to be measured from the feedpoint, down the coaxial cable, through the equipment in the shack, and away to down to RF ground via various lengths and loops of wire and metal plumbing. There can be many additional loading effects, which alter the resonant length from its free-space value, so it can be very difficult to identify the

exact causes of feedline resonance. If a choke-type balun fails to suppress feedline currents, the solution is to leave the balun there, and place further RF chokes, see Figs 14.23(a), (b) and (c), at intervals down the feedline to interrupt any resonant current distributions. A suitable interval would be a quarter-wavelength, or in a multi-band system you could use pairs of chokes 2.5 to 3m apart, avoiding half-wave separations at any frequency in use.

**Transformer or voltage baluns**

A balanced antenna feedpoint will present an equal impedance from each side to ground. The accusation levelled at choke baluns is that they treat the symptom (the surface current I3) without attempting to correct the imbalance that causes it. A transformer balun, on the other hand, does create equal and opposite RF voltages at its output terminals, relative to the grounded side of its input. This works fine in the laboratory; but up in the air where the balun is located, what exactly do we mean by 'grounded'?

Voltage baluns may or may not involve a deliberate impedance transformation. Fig 14.24 shows a wire-wound 1:1 balun, and both wire-wound and coaxial-cable versions of the 4:1 type. These all have the common property of forcing balance at their output terminals by means of closely coupled windings within the transformer itself. The 4:1 balun in Fig 14.24(b) is the easiest to understand. Typically, it transforms 50Ω unbalanced to 4 x 50 = 200Ω balanced. This is achieved simply by a phase inversion. An applied voltage v at one side of the feedpoint is converted by the transformer action into a voltage - v at the other side. These two voltages 180° out of phase represent the balance we are seeking to achieve. The 4:1 impedance transformation arises as follows. If the original voltage on the feedline was v, the voltage difference between opposite sides of the feedpoint is now 2v.

MHz	RG213/UR67		RG58/UR76	
	feet	turns	feet	turns
<i>Single-band (very effective)</i>				
3.5	22	8	20	6-8
7	22	10	15	6
10	12	10	10	7
14	10	4	8	8
21	8	6-8	6	8
28	6	6-8	4	6-8
<i>Multiband (good compromise)</i>				
3.5-30	10	7	10	7
3.5-10	18	9-10	18	9-10
14-30	8	6-7	8	6-7

**Table 14.1: Coiled-coax feeding chokes for HF. Wind the indicated length of coaxial cable into a flat coil and tape it together. (Source - W7EL, ARRL Antenna Handbook)**

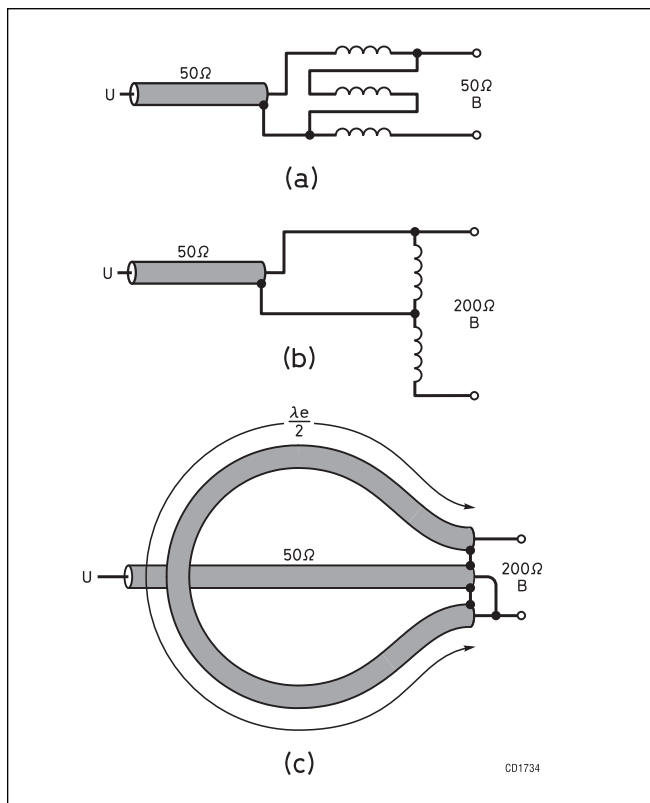

**Fig 14.24: Transformer/voltage - type baluns. Windings shown separately are bifilar or trifilar wound, possibly on a ferrite rod or core. (a) wire-wound 1:1 (trifilar). (b) Wire-wound 4:1 (bifilar). (c) Coaxial 4:1. The half-wavelength must allow for the velocity factor of the cable**

Since impedance is proportional to voltage squared, and  $(2v)^2 = 4v^2$ , the impedance is stepped up by a factor of 4.

In the wire-wound 4:1 balun shown in Fig 14.24(b), the 180° phase inversion is achieved by the connection of the windings, while the coaxial equivalent in Fig 14.24(c) does it by introducing an electrical half-wavelength of cable between opposite sides of the feedpoint. Strong coupling between the windings and inside the coax forces the whole system into balance.

However, if any balun is treated as a 'black box' and we look at the currents flowing in and out, it is apparent that any current difference between the two sides of the antenna has nowhere else to flow but down the outside of the coax. But that does not mean that the balun is no better than a direct connection; when you insert the balun, it forces the currents in the antenna to readjust and become more symmetrical. To make a meaningful evaluation of the effects of a balun, you therefore need to include the entire antenna and its surroundings in your analysis.

Any unbalanced antenna/feedline system will always 'push back' against an attempt to force it into symmetry. So although the transformer balun may do a good job, it still may not achieve total equality between the currents on opposite sides of the feed point. That may leave a residual difference current  $I_3$  to flow down the outside of the coax, as noted above. Unfortunately, having made its effort to minimise that difference current, the transformer balun does nothing to prevent it from flowing onto the coax. And there is still the possibility of additional currents being induced further down the surface of the feedline. This implies that a transformer-type balun may require additional RF chokes at the balun itself and possibly further back down the line.

### Which HF Balun is Best?

W7EL [7] has made some direct comparative tests between choke and transformer baluns in something approximating a real situation. The baluns were inserted between a horizontal 28MHz dipole and a half-wavelength of coaxial feeder. Since the transmitter end of the feeder was well grounded, this feeder length presents a particularly low impedance to surface currents at the feedpoint, and places great demands on the balun. W7EL measured the currents in the dipole at both sides of the feedpoint, and also the imbalance current on the surface of the coax. He found that even minor physical asymmetry in the installation resulted in marked electrical asymmetry; and that both types of baluns produced improvements.

Many amateurs have found this for themselves. Whichever type of balun cures your particular problems (such as RF in the shack or EMC), it's good enough. However, in W7EL's experiments the choke balun produced consistently better improvements in balance than the transformer or voltage type. This is consistent with the lack of direct effort in the transformer balun to suppress feedline surface currents.

### VHF and UHF Baluns

At VHF and UHF there are generally fewer difficulties with imbalance created by the antenna's surroundings. The problem is usually the difficulty of making a symmetrical junction at the feedpoint, because the lengths of connecting wires and the necessary gap at the centre of a dipole become significant fractions of the wavelength.

For all its popularity the gamma match is not a balun. It does nothing to create balance between the two sides of a dipole; on the contrary, it relies entirely on electromagnetic coupling between the opposite sides of the dipole to correct the imbalance of the gamma match itself. When used with an all-metal Yagi, the direct connection of the coax shield to the centre of the dipole invites the resulting imbalance currents to travel along the boom as well as the outer surface of the feedline.

The coaxial half-wave balun is definitely the 'best buy' for all VHF/UHF bands up to at least 432MHz, see Fig 14.24(c). It strongly enforces balance, yet it does not introduce an impedance mismatch unless the cable or its length is markedly different from a true electrical half-wavelength. The problem with using this balun is that the feedpoint impedance of the antenna must be transformed up to 200Ω. Fortunately, this is often very simple. For example, the highly successful family of DL6WU long Yagis [8] have a feedpoint impedance which is close to 50Ω at the centre of the dipole driven element; this impedance can be raised to the necessary 200Ω simply by converting the driven element into a folded dipole. Other alternatives for creating a symmetrical 200Ω feedpoint impedance include the T match and the delta match.

The impedance of the coaxial cable used in a half-wave balun is not important, though characteristic impedance of one-half the load impedance (ie in most cases 100Ω) has been shown to give optimum broadband balance. Low-loss 100ohm coax is difficult to obtain, though, and it is perfectly adequate to use good-quality 50Ω cable, carefully cut to length with an allowance for the velocity factor.

### The PA0SE HF Balun

This HF balun design, by Dick Rollema, PA0SE, [9] was the solution for feeding an all-band (7MHz to 29MHz) antenna. The feed impedance of this antenna ranged from 33Ω on 7MHz to 560Ω on 29MHz and highly reactive, although balanced. This ruled out direct single-coax feed and also the use of ferrite or powdered iron in the baluns. Units with a 4:1 impedance ratio promised a

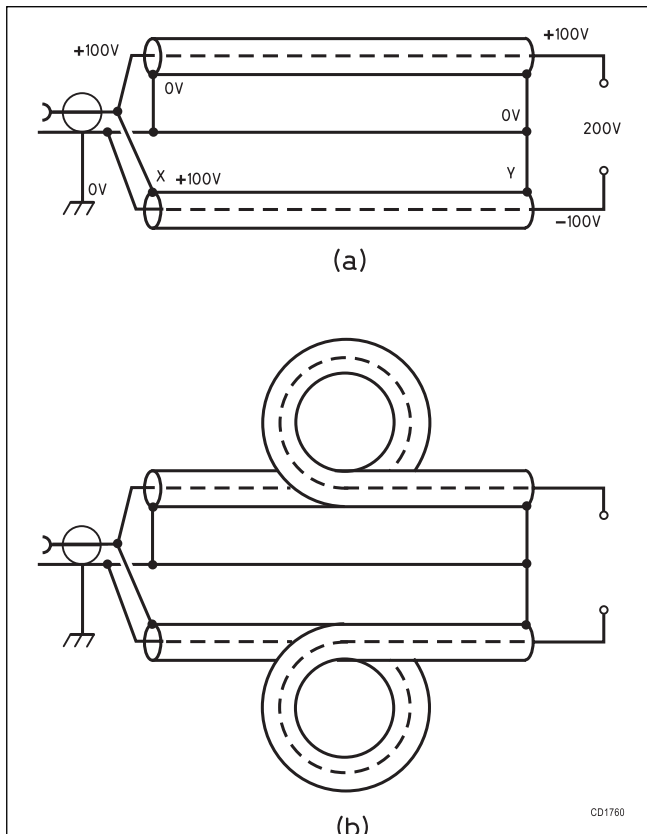

**Fig 14.25: Principle of the 4:1 coax balun. Short-circuiting the voltage between X and Y in (a) is remedied by the self-inductance created by coiling the coax as in (b). The upper coax is coiled for neatness only**

better match to his 17m of RG21 7/U to the shack than 1:1 baluns, especially on the highest frequencies, where the coaxial cable feeder losses due to mismatch were highest.

### How it works

The balun is made from coaxial cable as shown in **Fig 14.25(a)**. Two equal lengths are connected in parallel at their unbalanced left hand ends and in series at the balanced right hand ends. Let us assume that instantaneous HF voltage can be measured on the centre pin of the left hand coax connector and that this voltage is +100V with respect to earth. The result is +100V on the top balanced terminal and -100V on the bottom balanced terminal, ie 200V between them, balanced with respect to earth. However, with straight lengths of coax there would be a short-circuit between the +100V at point X and 0V at Y.

This short is eliminated by coiling the lower cable as shown in **Fig 14.25(b)**. Between X and Y there is now the reactance of that coil; if sufficiently high, point X no longer 'sees' point Y and there can be a voltage difference between them. For the top coax there is no such problem as both ends are at the same potential, but it is coiled for neatness.

This balun produces a 4:1 impedance transformation only if both cables are terminated in their characteristic impedance. PAOSE used 75Ω coax, so for 'flat' lines a purely resistive, balanced load of  $2 \times 75 = 150\Omega$  would be required. Looking into the unbalanced end of the balun, an impedance of  $75/2 = 37.5\Omega$  would then be seen.

With most antennas the feed impedance is anything but 150Ω resistive. Unless the length of the cables in the balun is short with respect to the wavelength, the balun produces an additional impedance transformation which is largest when the

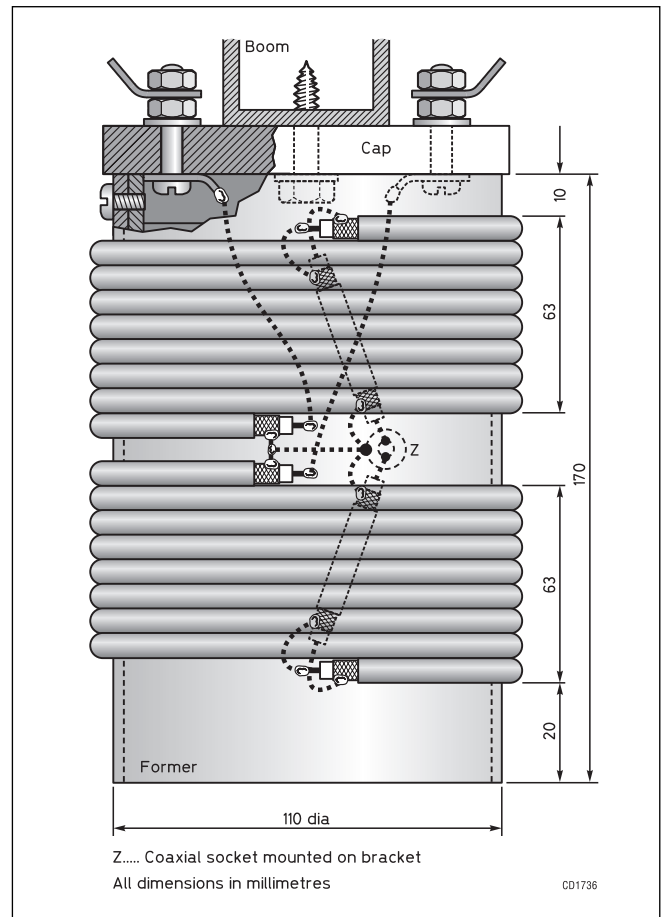

**Fig 14.26: Construction of a 4:1 balun of 75ohm coax on a PVC former. The dashed connections are inside the former**

cable lengths are near  $\lambda/4$ . This can add to or subtract from the 4:1 ratio. In the extreme, the impedance at the unbalanced end can even be higher than that of the balanced load! But that does no harm; the balancing action is valid over the whole intended frequency and impedance range.

### Construction

The balun assembly, with dimensions, is shown in **Fig 14.26**. None of these dimensions or the materials and cable types are critical. The former on the prototype was made of grey 110mm OD PVC waste pipe.

PAOSE used matching end caps for the balanced ends; these are not cemented on, but made removable by securing them with three self-tapping stainless steel screws. An N-socket (not shown) on a copper bracket is mounted inside the former for connection to the RG21 3/U coax feeder at point Z. N-connectors are waterproof by design and, additionally, are sheltered by the former.

On the prototype, off-cuts from a 75Ω cable TV installation, whose specification is similar to Uniradio M203, was used.

The Balun is made from two equal lengths of cable wound into the two 8-turn coils (note the winding direction). They are held in place by the ends of the bare-wire jumpers, which protrude through snug-fit holes in the former.

At the balanced end of the coils the braids are joined and connected to the N-socket outer, via a bare wire jumper. The centre conductors are connected to the balanced terminals using bare wire jumpers (shown with dotted lines). The unbalanced outer ends of the coax coils are connected by short lengths of coax inside the former to the N-socket.

Note that the inside conductor of the coax link is connected to the top coil braid and the braid to the inner conductor (on the top coil only).

All coax ends, solder connections and feed-through holes were fixed and waterproofed with epoxy cement. Three coats of clear yacht varnish protect the completed assembly against ultra-violet light. After four years use, the baluns are as good as new.

### MATCHING THE ANTENNA TO THE TRANSMISSION LINE

Wire HF antennas are often used with an Antenna Tuning Unit, described in detail in the chapter on Practical HF Antennas. Another method is to use a matching arrangement at the antenna, particularly with beam antennas. Some of the more popular matching arrangements are described below.

#### The Direct Connection

The halfwave dipole has a theoretical centre feedpoint impedance of 75Ω at resonance. In practice this value is less, particularly at HF, because of the presence of ground. Generally the centre of a dipole can be connected directly to 50Ω coax cable as shown in the Practical HF Antennas chapter, and will almost always provide a good match. A current balun, described earlier, may be necessary at higher transmitter powers.

#### The Folded Dipole

A halfwave antenna that is used as the driven element will normally have a feedpoint impedance much lower than 50Ω. In this case some impedance transformation is required.

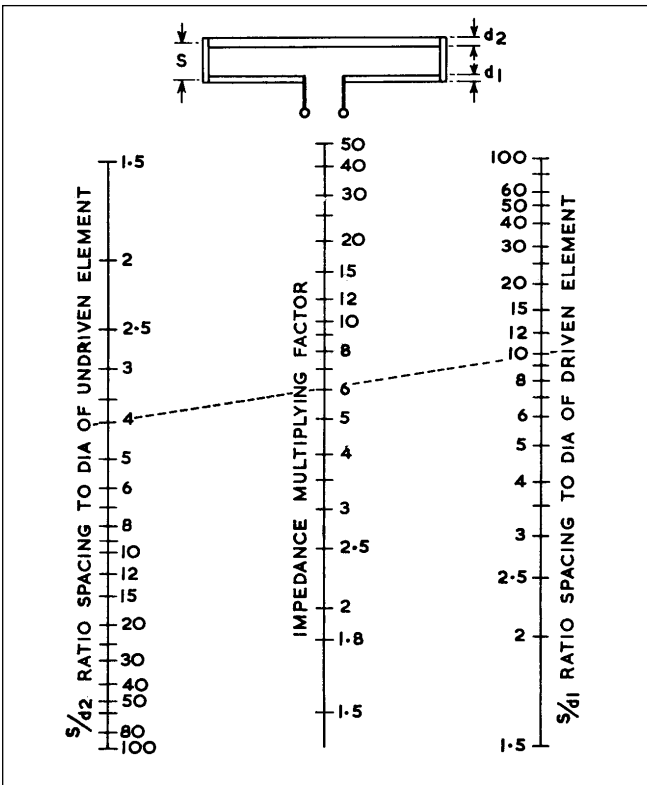

Fig 14.27: A nomogram for folded dipole impedance ratio calculations. A ruler laid across the scales will give pairs of spacing/diameter ratio for any required multiplier. In the example shown the driven element diameter is one-tenth of the spacing and the other element diameter is one-quarter of the spacing, resulting in a setup of 6:1. This shows an unlimited number of solutions for a given ratio

A transformer can be used to step the antenna impedance up to the correct value but this can have the effect of reducing the bandwidth. It has been found that by folding the antenna a 4:1 impedance step-up can often be accomplished with an increase in impedance bandwidth.

Other ratios of transformation than four can be obtained by using different conductor diameters for the elements of the radiator. When this is done, the spacing between the conductors is important and can be varied to alter the transformation ratio. The relative size and spacing can be determined with the aid of the nomogram in Fig 14.27.

#### The Gamma Match

The Gamma match is an unbalanced feed system suitable for matching coax transmission line to the driven element of a beam. Because it is well suited to plumber's delight construction, where all the metal parts are electrically and mechanically connected to the boom, it has become quite popular for amateur arrays.

A short length of conductor (often known as the gamma rod) is used to connect the centre of the coax to the correct impedance point on the antenna element. The reactance of the matching section can be cancelled either by shortening the antenna element appropriately or by using the resonant antenna element length and installing a series capacitor C, as shown in Fig 14.28.

Because of the many variable factors - driven-element length, gamma rod length, rod diameter, spacing between rod and driven element, and value of series capacitors - a number of combinations will provide the desired match. The task of finding a proper combination can be sometimes be tedious because the settings are interrelated.

For matching a multi-element array made of aluminum tubing to 50Ω line, the length of the gamma rod should be 0.04 to 0.05 wavelengths long and its diameter 1/3 to 1/2 that of the driven element. The centre-to-centre gamma rod / driven element (S in Fig 14.28) is approximately 0.007 wavelengths. The capacitance value should be approximately 7pF per metre of wavelength at the operating frequency. This translates to about 140pF for 20 metre operation. The exact gamma dimensions and value for the capacitor will depend on the radiation resistance of the driven element, and whether or not it is resonant. The starting-point

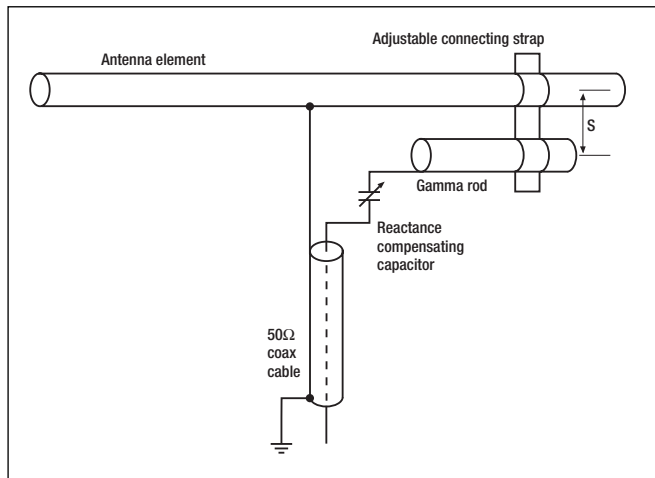

Fig.14.28: Diagram of a Gamma match. Matching is achieved by altering the position of the gamma rod adjustable connecting strap point on the antenna element. The series capacitor C also has to be adjusted to cancel the inductance of the gamma rod. See text for approximate dimensions





**Fig 14.29: Simplified Gamma match by G3LDO, uses hard drawn copper wire as the gamma rod. Connection of the gamma rod to the antenna element is achieved using a hose clamp. A Philips capacitor is used as a reactance correction capacitor, which can be replaced with a fixed mica capacitor of the correct value (see text) once the adjustments are complete.**

dimensions quoted are for an array having a feed-point impedance of about  $25\Omega$ , with the driven element shortened approximately 3% from resonance.

### Adjustment

After installation of the antenna, the proper constants for the gamma generally must be determined experimentally. The use of the variable series capacitor, as shown in Fig 14.28, is recommended for ease of adjustment.

With a trial position of the tap or taps on the antenna, measure the SWR on the transmission line and adjust C1 for minimum SWR. If it is not close to 1:1, try another tap position and repeat.

### Construction

The gamma rod is made from thin aluminium tube whose diameter recommended in most publications is  $1/3$  to  $1/6$ th of the antenna element diameter. However, it is worth trying what is to hand. The Simplified Gamma match by G3LDO, uses hard drawn copper wire as the gamma rod whose connection to the antenna element is achieved using a hose clamp.

The traditional method of making a gamma match is to use an air-spaced variable capacitor and enclose it in a weatherproof metal box. Corrosion to the capacitor can still occur because of condensation.

The gamma match shown in Fig 14.29 uses a fixed capacitor whose value is determined by experiment with a variable capacitor. The value of the variable capacitor is then measured and a fixed capacitor (or several series/parallel combinations) substituted. This arrangement will handle 100W without breakdown and only requires a smear of grease to achieve weatherproofing.

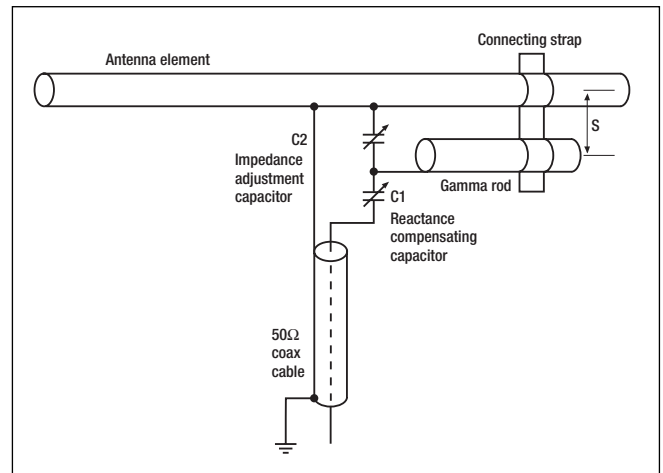

**Fig.14.30: Diagram of an Omega match. Matching is achieved by adjusting the parallel capacitor C2 and the series capacitor C1**

## The Omega Match

The Omega match is a slightly modified form of the gamma match. In addition to the series capacitor, a shunt capacitor is used to aid in cancelling a portion of the inductive reactance introduced by the gamma section. This is shown in Fig 14.30. C1 is the usual series capacitor. The addition of C2 makes it possible to use a shorter gamma rod, and makes it easier to obtain the desired match when the driven element is resonant. During adjustment, C2 will serve primarily to determine the resistive component of the load as seen by the coax line, and C1 serves to cancel any reactance. Fixed capacitors can be used to replace the variable ones once the matching procedure is complete. In general the dimensions are the same as for the Gamma match but the gamma rod can be shortened up to 50%. The maximum value of C2 is approximately  $1.4\text{pF}$  per metre of the operating frequency.

## REFERENCES

- [1] 'Smith Radio Transmission-Line Calculator'. Phillip H Smith, *Electronics*, Jan 1939.
- [2] *The ARRL Antenna Book*, 20th edition, ARRL.
- [3] *The Antenna Experimenter's Guide*, 2nd Edition, Peter Dodd, G3LDO
- [4] 'Fitting Coaxial Connections', Roger Blackwell, G4PMK, *RadCom* May 1988
- [5] 'In Practice', Ian White, G3SEK, *Radcom*, Jun 1998
- [6] 'Balanced to Unbalanced Transformers', Ian White, G3SEK, *RadCom*, Dec 1989
- [7] 'Baluns: what they do and how they do it', Roy W Lewallen, W7EL, *ARRL Antenna Book*. (W7EL coined the term 'current balun' for the type described in this article as a choke balun, and 'voltage balun' for the transformer type.)
- [8] 'High performance long Yagis', Ian White, G3SEK, *RadCom*, Apr 1987. See also Chapter 7
- [9] 'Eurotek', Erwin David, G4LQI, *Radcom*, Aug 1992

The following three pages contain Smith charts that may be copied and enlarged to make a Smith cart calculator as described earlier in this chapter.

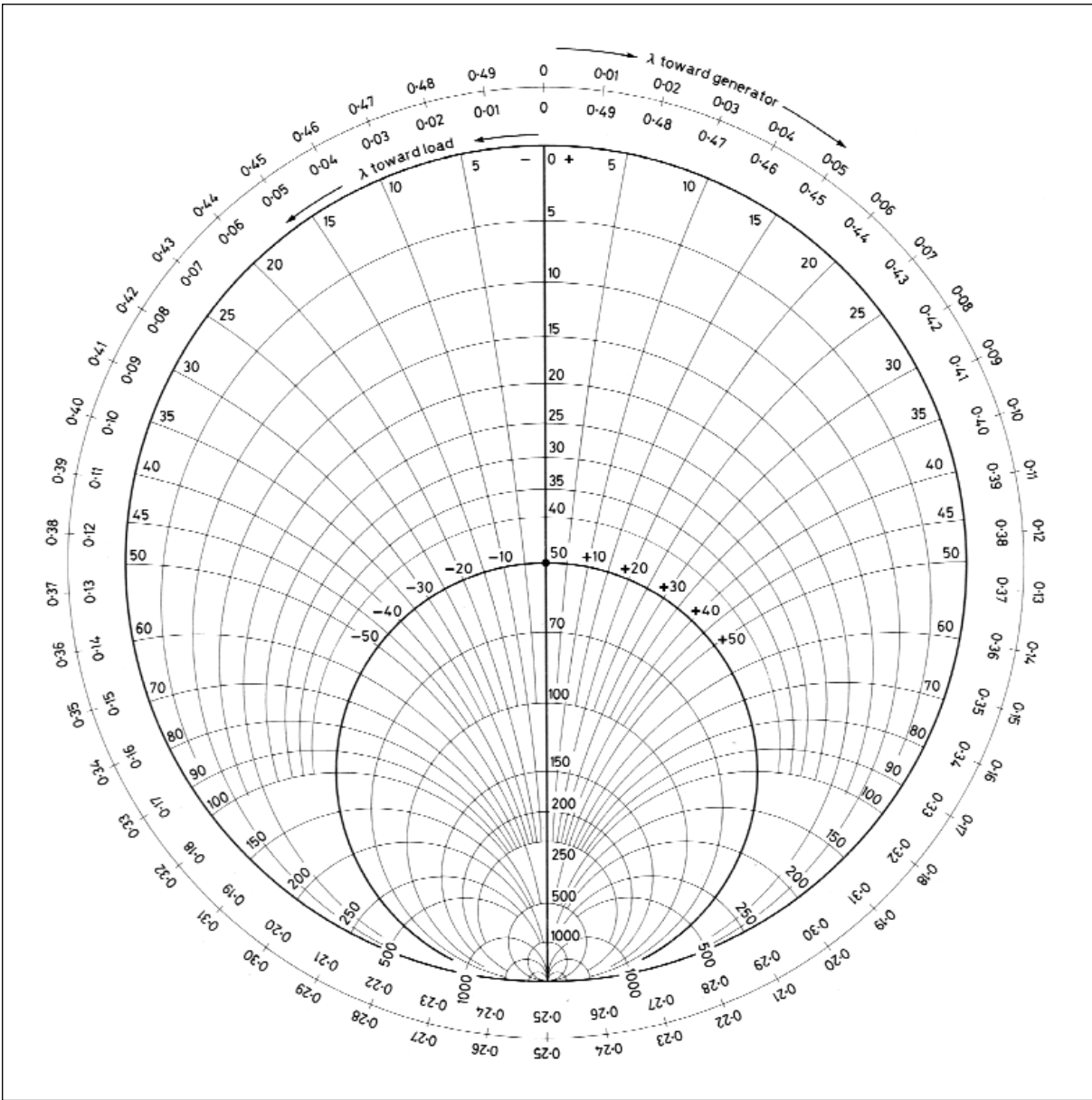

Fig.14.31: Smith chart for constructing a 50-ohm impedance calculator

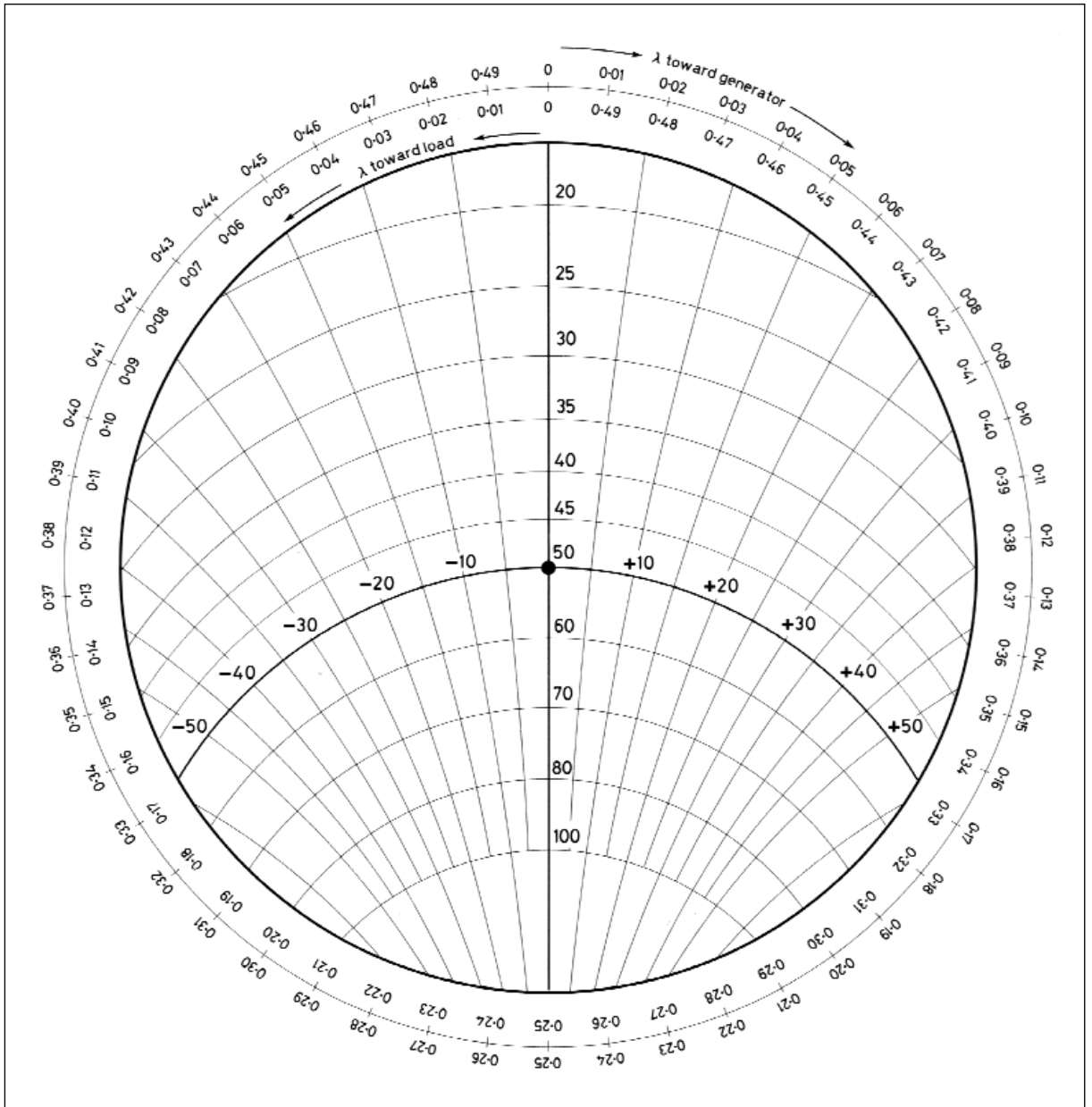

Fig.14.32: Smith chart for constructing a restricted range 50-ohm impedance calculator

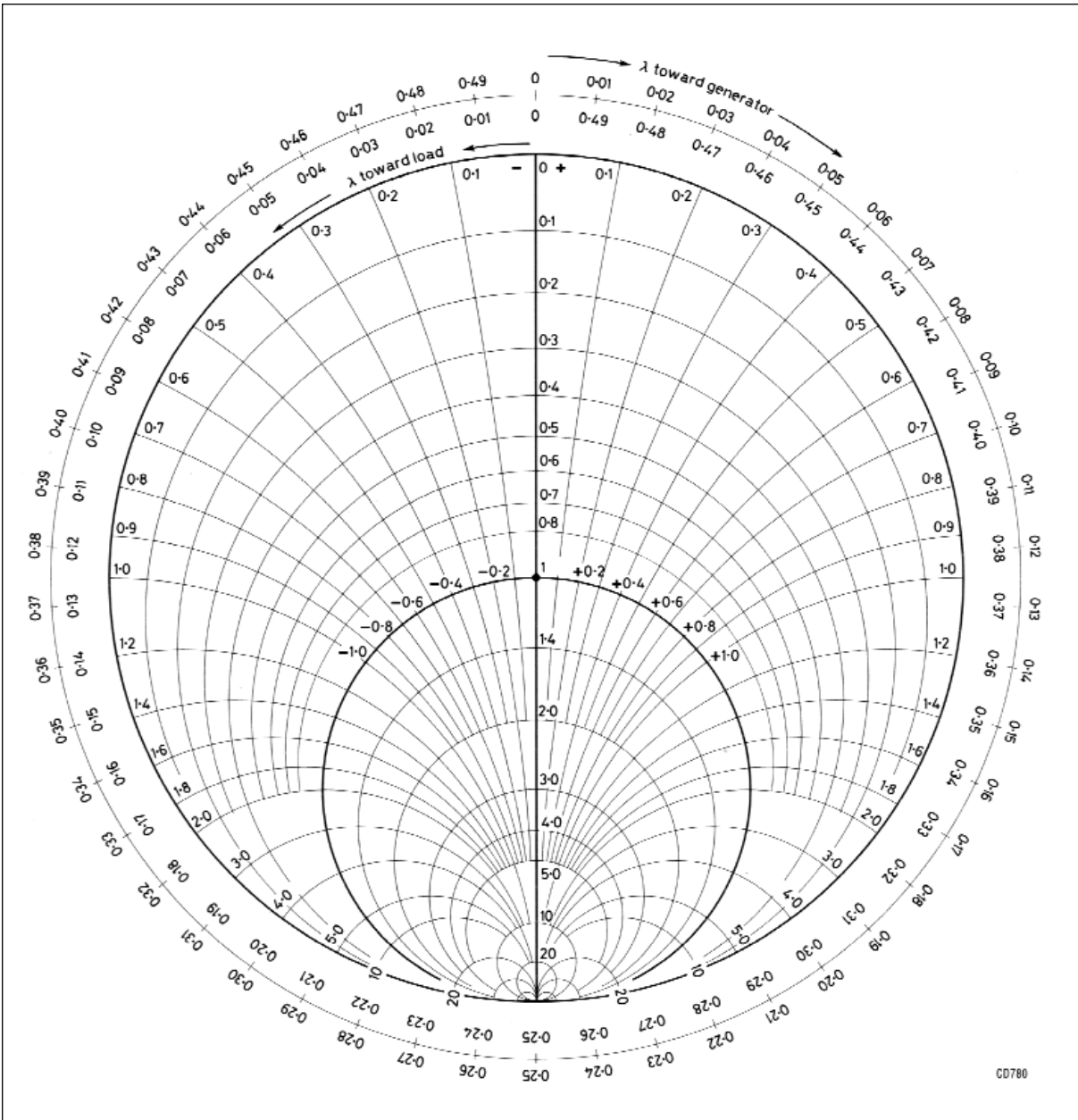

Fig.14.33: Smith chart for constructing a normalised impedance calculator