

Appendix A

General Data

Capacitance

The capacitance of a parallel-plate capacitor is:

$$C = \frac{0.224 KA}{d} \text{ picofarads}$$

where K is the dielectric constant (air = 1.0), A is the area of dielectric (sq in), and d is the thickness of dielectric (in).

If A is expressed in centimetres squared and d in centimetres, then:

$$C = \frac{0.0885 KA}{d} \text{ picofarads}$$

For multi-plate capacitors, multiply by the number of dielectric thicknesses.

The capacitance of a coaxial cylinder is:

$$C = \frac{0.242}{\log_{10}(D/d)} \text{ picofarads per centimetre length}$$

where D is the inside diameter of the outer and d is the outside diameter of the inner.

Capacitors in series or parallel

The effective capacitance of a number of capacitors in *series* is:

$$C = \frac{1}{\frac{1}{C_1} + \frac{1}{C_2} + \frac{1}{C_3} + \text{etc}}$$

The effective capacitance of a number of capacitors in *parallel* is:

$$C = C_1 + C_2 + C_3 + \text{etc}$$

Characteristic impedance

The characteristic impedance Z_0 of a feeder or transmission line depends on its cross-sectional dimensions.

(i) *Open-wire line*:

$$Z_0 = 276 \log_{10} \frac{2D}{d} \text{ ohms}$$

where D is the centre-to-centre spacing of wires (mm) and d is the wire diameter (mm).

(ii) *Coaxial line*:

$$Z_0 = \frac{138}{\sqrt{K}} \log_{10} \frac{d_o}{d_i} \text{ ohms}$$

where K is the dielectric constant of insulation between the conductors (eg 2.3 for polythene, 1.0 for air), d_o is the inside diameter of the outer conductor and d_i is the diameter of the inner conductor.

Decibel

The *decibel* is the unit commonly used for expressing the relationship between two power levels (or between two voltages or two currents). A decibel (dB) is one-tenth of a *bel* (B). The number of decibels N representing the ratio of two power levels P_1 and P_2 is 10 times the common logarithm of the power ratio, thus:

$$\text{The ratio } N = 10 \log_{10} \frac{P_2}{P_1} \text{ decibels}$$

If it is required to express *voltage* (or *current*) ratios in this way, they must relate to identical impedance values, ie the two different voltages must appear across equal impedances (or the two different currents must flow through equal impedances). Under such conditions the *power* ratio is proportional to the square of the *voltage* (or the *current*) ratio, and hence:

$$N = 20 \log_{10} \frac{V_2}{V_1} \text{ decibels}$$

$$N = 20 \log_{10} \frac{I_2}{I_1} \text{ decibels}$$

Dynamic resistance

In a parallel-tuned circuit at resonance the dynamic resistance is:

$$R_D = \frac{L}{Cr} = Q\omega L = \frac{Q}{\omega C} \text{ ohms}$$

where L is the inductance (henrys), C is the capacitance (farads), r is the effective series resistance (ohms), Q is the Q -value of the coil and $\omega = 2\pi \times$ frequency (hertz).

Frequency – wavelength – velocity

The velocity of propagation of a wave is:

$$v = f\lambda \text{ metres per second}$$

where f is the frequency (hertz) and λ is the wavelength (metres).

For electromagnetic waves in free space the velocity of propagation v is approximately 3×10^8 m/s and, if f is expressed in kilohertz and λ in metres:

$$f = \frac{300,000}{\lambda} \text{ kilohertz}$$

$$\lambda = \frac{300,000}{f} \text{ metres}$$

$$\text{Free space } \frac{\lambda}{2} = \frac{492}{\text{MHz}} \text{ feet}$$

$$\text{Free space } \frac{\lambda}{4} = \frac{246}{\text{MHz}} \text{ feet}$$

Note that the true value of v is 2.99776×10^8 m/s.

Impedance

The impedance of a circuit comprising inductance, capacitance and resistance in series is:

$$Z = \sqrt{R^2 + \left(\omega L - \frac{1}{\omega C}\right)^2}$$

where R is the resistance (ohms), L is the inductance (henrys), C is the capacitance (farads) and $\omega = 2\pi \times$ frequency (hertz).

Inductors in series or parallel

The total effective value of a number of inductors connected in series (assuming that there is no mutual coupling) is given by:

$$L = L_1 + L_2 + L_3 + \text{etc}$$

If they are connected in parallel, the total effective value is:

$$L = \frac{1}{\frac{1}{L_1} + \frac{1}{L_2} + \frac{1}{L_3} + \text{etc}}$$

When there is mutual coupling M , the total effective value of two inductors connected in series is:

$$L = L_1 + L_2 + 2M \text{ (windings aiding)}$$

$$\text{or } L = L_1 + L_2 - 2M \text{ (windings opposing)}$$

Ohm's Law

For a unidirectional current of constant magnitude flowing in a metallic conductor:

$$I = \frac{E}{R} \quad E = IR \quad R = \frac{E}{I}$$

where I is the current (amperes), E is the voltage (volts) and R is the resistance (ohms).

Power

In a DC circuit, the power developed is given by:

$$W = EI = \frac{E^2}{R} = PR \text{ watts}$$

where E is the voltage (volts), I is the current (amperes) and R is the resistance (ohms).

Q

The Q -value of an inductance is given by:

$$Q = \frac{\omega L}{R}$$

where L is the inductance (henrys), R is the effective resistance (ohms) and $\omega = 2\pi \times$ frequency (hertz).

Reactance

The reactance of an inductance and a capacitance respectively is given by:

$$X_L = \omega L \text{ ohms}$$

$$X_C = \frac{1}{\omega C} \text{ ohms}$$

where L is the inductance in henrys, C is the capacitance in farads and $\omega = 2\pi \times$ frequency (hertz).

The total reactance of an inductance and a capacitance in series is $X_L - X_C$.

Resistors in series or parallel

The effective value of several resistors connected in series is:

$$R = R_1 + R_2 + R_3 + \text{etc}$$

When several resistors are connected in parallel the effective total resistance is:

$$R = \frac{1}{\frac{1}{R_1} + \frac{1}{R_2} + \frac{1}{R_3} + \text{etc}}$$

Resonance

The resonant frequency of a tuned circuit is given by:

$$f = \frac{1}{2\pi\sqrt{LC}} \text{ hertz}$$

where L is the inductance (henrys) and C is the capacitance (farads).

If L is in microhenrys (μH) and C is picofarads (pF), this formula becomes:

$$f = \frac{10^3}{2\pi\sqrt{LC}} \text{ megahertz}$$

The basic formula can be rearranged thus:

$$L = \frac{1}{4\pi^2 f^2 C} \text{ henrys}$$

$$C = \frac{1}{4\pi^2 f^2 L} \text{ farads}$$

Since $2\pi f$ is commonly represented by ω , these expressions can be written as:

$$L = \frac{1}{\omega^2 C} \text{ henrys}$$

$$C = \frac{1}{\omega^2 L} \text{ farads}$$

See Figs 23.1 and 23.2.

Time constant

For a combination of inductance and resistance in series the time constant (ie the time required for the current to reach $1/\epsilon$ or 63% of its final value) is given by:

$$t = \frac{L}{R} \text{ seconds}$$

where L is the inductance (henrys) and R is the resistance (ohms).

For a combination of capacitance and resistance in series, the time constant (ie the time required for the voltage across the capacitance to reach $1/\epsilon$ or 63% of its final value) is given by:

$$t = CR \text{ seconds}$$

where C is the capacitance (farads) and R is the resistance (ohms).

Transformer ratios

The ratio of a transformer refers to the ratio of the number of turns in one winding to the number of turns in the other winding. To avoid confusion it is always desirable to state in which sense the ratio is being expressed, eg the 'primary-to-secondary' ratio n_p/n_s . The turns ratio is related to the impedance ratio thus:

$$\frac{n_p}{n_s} = \sqrt{\frac{Z_p}{Z_s}}$$

where n_p is the number of primary turns, n_s is the number of secondary turns, Z_p is the impedance of the primary circuit (ohms) and Z_s is the impedance of the secondary circuit (ohms).

COIL WINDING

Most inductors for tuning in the HF bands are single-layer coils and they are designed as follows. Multilayer coils will not be dealt with here.

The inductance of a single-layer coil is given by:

$$L (\mu\text{H}) = \frac{D^2 \times T^2}{457.2 \times D + 1016 \times L}$$

where D is the diameter of the coil (millimetres), T is the number of turns and L is the length (millimetres). Alternatively:

$$L (\mu\text{H}) = \frac{R^2 \times T^2}{9 \times R + 10 \times L}$$

where R is the radius of the coil (inches), T is the number of turns and L is the length (inches).

Note that when a ferrite or iron dust core is used, the inductance will be increased by up to twice the value without the core. The choice of which to use depends on frequency. Generally, ferrite cores are used at the lower HF bands and iron dust cores at the higher. At VHF, the iron dust cores are usually coloured purple. Cores need to be moveable for tuning but fixed thereafter and this can be done with a variety of fixatives. A strip of flexible polyurethane foam will do.

Designing inductors with ferrite pot cores

This is a simple matter of taking the *factor* given by the makers and multiplying it by the square of the number of turns.

Example

A RM6-S pot core in 3H1 grade ferrite has a ‘factor’ of 1900 nanohenrys for one turn. Therefore 100 turns will give an inductance of:

$$100^2 \times 1900\text{nH} = 10000 \times 1900\text{nH} = 19\text{mH}$$

There are a large number of different grades of ferrite; for example, the same pot as above is also available in grade 3E4 with a ‘factor’ of 3300. Manufacturers’ literature should be consulted to find these ‘factors’.

Table A.1

Diameter (mm)	Approx SWG	Turns/cm	Turns/in
1.5	16-17	6.6	16.8
1.25	18	7.9	20.7
1.0	19	9.9	25
0.8	21	12.3	31
0.71	22	13.9	35
0.56	24	17.5	45
0.50	25	19.6	50
0.40	27	24.4	62
0.315	30	30.8	78
0.25	33	38.5	97
0.224	34-35	42.7	108
0.20	35-36	47.6	121

Note: SWG is Imperial standard wire gauge. The diameters listed are those which appear to be most popular; ie they are listed in distributor’s catalogues. The ‘turns/cm’ and ‘turns/in’ are for enamelled wire.

Table A.2. Coaxial cables

Type	Nominal impedance (ohms)	Outside diameter (mm)	Velocity factor	Capacitance (pF/m)	Attenuation per 30m (100ft) of cable		
					10MHz (dB)	100MHz (dB)	1000MHz (dB)
RG58-U/UR43	52	5.0	0.66	100	1.0	3.3	10.6
RG213/UR67	50	10.3	0.66	100	0.68	2.26	8.0
Westflex 103	50	10.3	0.85	78	0.27	0.85	2.7
EchoFlex 15	50	14.6	0.86	77	0.26	0.28	2.9
LDF4-50	50	16	0.88	88	0.21	0.68	2.5
UR70	75	5.8	0.66	67	0.5	1.5	5.2
RG59BU	75	6.15	0.66	68	0.5	1.5	4.6
RG62AU	95	6.15	0.84	44	0.3	0.9	2.9

This short list of coaxial cables represents what is available in distributors’ advertisements.

The data in this table has been obtained from these catalogues and from the Internet.

Note that there are various standards of measuring coax loss, such as dB/100m, dB/10m and dB/100ft and at various frequencies.

The data above uses dB/30m (approximately 100ft) representing the most common length from the shack to the antenna.

Table A.3. Wire table

Diameter (mm)	Approx SWG	Max current (A)	Fusing current (A)	Resistance at 20°C (Ω/km)
2.5	12	7.6	325	3.5
2.0	14	4.9	225	5.4
1.5	16-17	2.7	147	9.7
1.0	19	1.2	81	22
0.71	22	0.61	46	43
0.5	26	0.30	28	87
0.25	32	0.076	10	351
0.20	36	0.049	7.1	541

‘Max current’ is the carrying capacity at 1.55A/mm². This is a very conservative figure and can usually be doubled. The ‘fusing current’ is approximate since it depends also on thermal conditions, ie if the wire is thermally insulated, it will fuse at a lower current.

Table A.16. Chebyshev low-pass filter (Pi configuration)

	Ripple (dB)	C_1	C_2	C_3	C_4	C_5	L_1	L_2	L_3	L_4
Single section (3-pole)	1	6441.3	6441.3	—	—	—	7.911	—	—	—
	0.1	3283.6	3283.6	—	—	—	9.131	—	—	—
	0.01	2007.7	2007.7	—	—	—	7.721	—	—	—
	0.001	1301.2	1301.2	—	—	—	5.781	—	—	—
Two-section (5-pole)	1	6795.5	9552.2	6795.5	—	—	8.683	8.683	—	—
	0.1	3650.4	6286.6	3650.4	—	—	10.91	10.91	—	—
	0.01	2407.5	5020.7	2407.5	—	—	10.38	10.38	—	—
	0.001	1727.3	4170.5	1727.3	—	—	8.928	8.928	—	—
Three-section (7-pole)	1	3538	5052	5052	3538	—	17.24	18.20	17.24	—
	0.1	3759.8	6673.9	6673.9	3759.8	—	11.32	12.52	11.32	—
	0.01	2536.8	5564.5	5564.5	2536.8	—	11.08	13.00	11.08	—
	0.001	1875.7	4875.9	4875.9	1875.7	—	9.879	12.31	9.879	—
Four-section (9-pole)	1	6938.3	9935.8	10,105	9935.8	6938.3	8.906	9.467	9.467	8.906
	0.1	3805.9	6794.5	7019.9	6794.5	3805.9	11.48	12.87	12.87	11.48
	0.01	2592.5	5743.5	6066.3	5743.5	2592.5	11.36	13.63	13.63	11.36
	0.001	1941.7	5124.6	5553.2	5124.6	1941.7	10.27	13.25	13.25	10.27

Inductance in microhenrys, capacitance in picofarads. Component values normalised to 1MHz and 50Ω.

Table A.17. Chebyshev high-pass filter ('T' configuration)

	Ripple (dB)	C_1	C_2	C_3	C_4	C_5	L_1	L_2	L_3	L_4
Single section (3-pole)	1	1573	1573	—	—	—	8.005	—	—	—
	0.1	3085.7	3085.7	—	—	—	6.935	—	—	—
	0.01	5059.1	5059.1	—	—	—	8.201	—	—	—
	0.001	7786.9	7786.9	—	—	—	10.95	—	—	—
Two-section (5-pole)	1	1491	1060.7	1491	—	—	7.293	7.293	—	—
	0.1	2775.6	1611.7	2775.6	—	—	5.803	5.803	—	—
	0.01	4208.6	2018.6	4208.6	—	—	6.098	6.098	—	—
	0.001	5865.7	2429.5	5865.7	—	—	7.093	7.093	—	—
Three-section (7-pole)	1	1469.2	1028.9	1028.9	1469.2	—	7.160	6.781	7.160	—
	0.1	2694.9	1518.2	1518.2	2694.9	—	5.593	5.058	5.593	—
	0.01	3994.1	1820.9	1820.9	3994.1	—	5.715	4.873	5.715	—
	0.001	5401.7	2078	2078	5401.7	—	6.410	5.144	6.410	—
Four-section (9-pole)	1	1460.3	1019.8	1002.7	1019.8	1460.3	7.110	6.689	6.689	7.110
	0.1	2662.2	1491.2	1443.3	1491.2	2662.2	5.516	4.922	4.922	5.516
	0.01	3908.2	1764.1	1670.2	1764.1	3908.2	5.578	4.647	4.647	5.578
	0.001	5216.3	1977.1	1824.6	1977.1	5216.3	6.657	4.780	4.780	6.657

Inductance in microhenrys, capacitance in picofarads. Component values normalised to 1MHz and 50Ω.

Table A.18. Chebyshev high-pass filter (Pi configuration)

	Ripple (dB)	L_1	L_2	L_3	L_4	L_5	C_1	C_2	C_3	C_4
Single section (3-pole)	1	3.932	3.932	—	—	—	3201.7	—	—	—
	0.1	7.714	7.714	—	—	—	2774.2	—	—	—
	0.01	12.65	12.65	—	—	—	3280.5	—	—	—
	0.001	19.47	19.47	—	—	—	4381.4	—	—	—
Two-section (5-pole)	1	3.727	2.652	3.727	—	—	2917.3	2917.3	—	—
	0.1	6.939	4.029	6.939	—	—	2321.4	2321.4	—	—
	0.01	10.52	5.045	10.52	—	—	2439.3	2439.3	—	—
	0.001	14.66	6.074	14.66	—	—	2837.3	2837.3	—	—
Three-section (7-pole)	1	7.159	5.014	5.014	7.159	—	1469.2	1391.6	1469.2	—
	0.1	8.737	3.795	3.795	8.737	—	2237.2	2023.1	2237.2	—
	0.01	9.985	4.552	4.552	9.985	—	2286.0	1949.1	2286.0	—
	0.001	13.50	5.195	5.195	13.50	—	2584.1	2057.7	2584.1	—
Four-section (9-pole)	1	3.651	2.549	2.507	2.549	3.651	2844.1	2675.6	2675.6	2844.1
	0.1	6.656	3.728	3.608	3.728	6.656	2206.5	1968.9	1968.9	2206.5
	0.01	9.772	4.410	4.176	4.410	9.772	2230.5	1858.7	1858.7	2230.5
	0.001	13.05	4.943	4.561	4.943	13.05	2466.3	1911.8	1911.8	2466.3

Inductance in microhenrys, capacitance in picofarads. Component values normalised to 1MHz and 50Ω.

would use two inductances of a value equal to $L_k/2$, while the balanced constant- k π -section high-pass filter would use two capacitors of a value equal to $2C_k$.

If several low- (or high-) pass sections are to be used, it is advisable to use m -derived end sections on either side of a constant- k section, although an m -derived centre section can be used.

Table A.11. Component colour codes

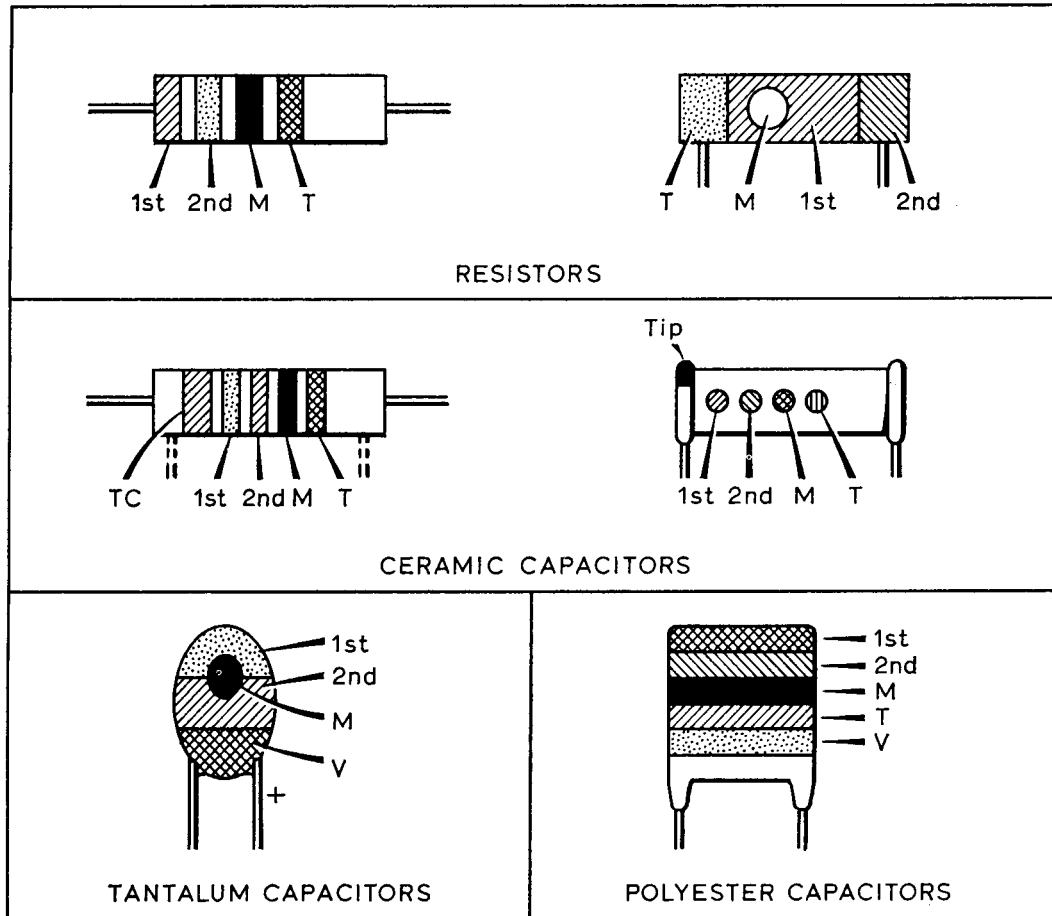

Colour	Significant figure (1st, 2nd)	Decimal multiplier (M)	Tolerance (T) (per cent)	Temp coeff (TC) (parts/10 ⁶ /°C)	Voltage (V) (tantalum cap)	Voltage (V) (polyester cap)
Black	0	1	±20	0	10	—
Brown	1	10	±1	-30	—	100
Red	2	100	±2	-80	—	250
Orange	3	1000	±3	-150	—	—
Yellow	4	10,000	+100, -0	-220	6.3	400
Green	5	100,000	±5	-330	16	—
Blue	6	1,000,000	±6	-470	20	—
Violet	7	10,000,000	—	-750	—	—
Grey	8	100,000,000	—	+30	25	—
White	9	1,000,000,000	±10	+100 to -750	3	—
Gold	—	0.1	±5	—	—	—
Silver	—	0.01	±10	—	—	—
Pink	—	—	—	—	35	—
No colour	—	—	±20	—	—	—

Units used are ohms for resistors, picofarads for ceramic and polyester capacitors, and microfarads for tantalum capacitors.

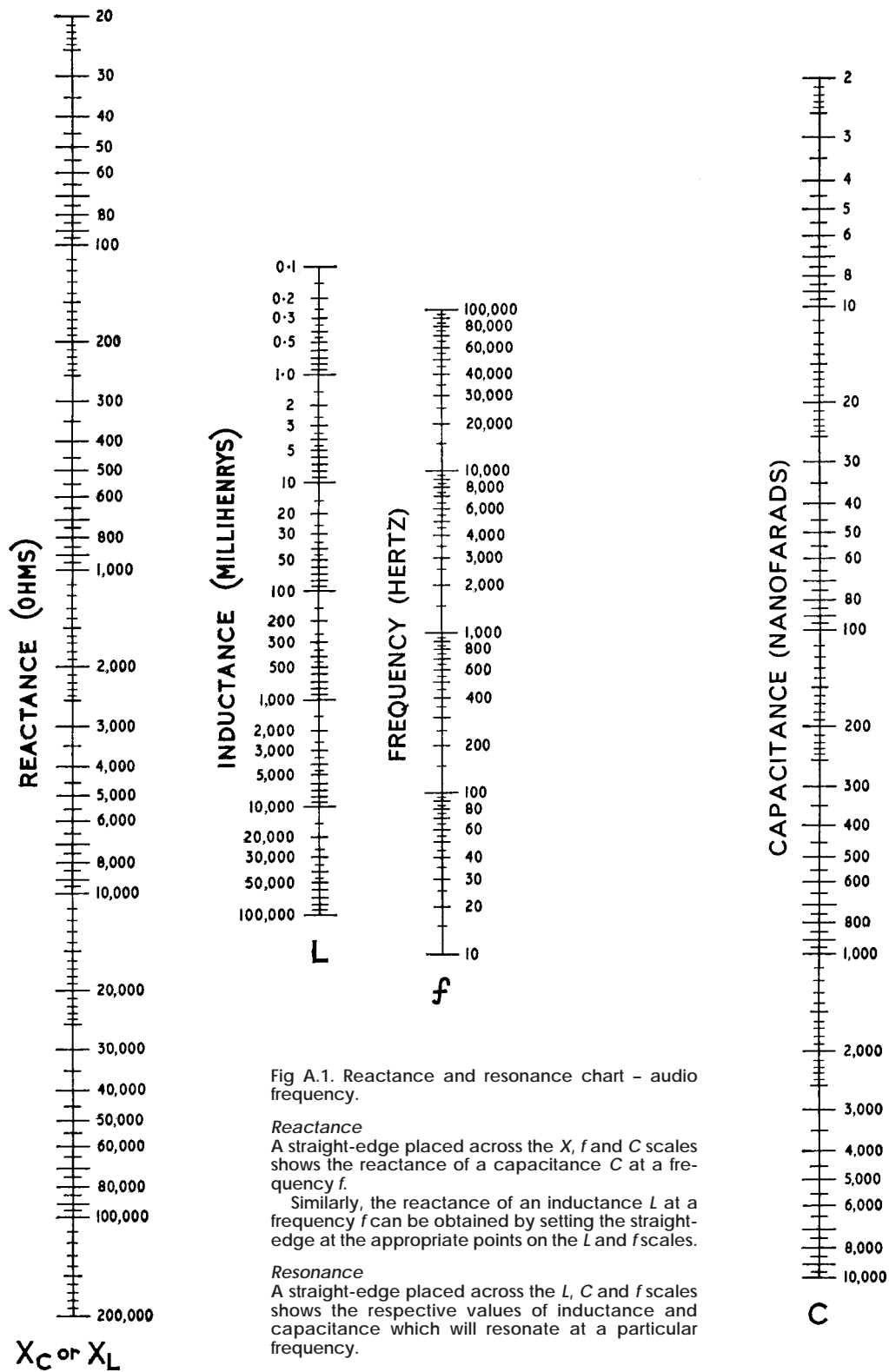

Fig A.1. Reactance and resonance chart - audio frequency.

Reactance

A straight-edge placed across the X , f and C scales shows the reactance of a capacitance C at a frequency f .

Similarly, the reactance of an inductance L at a frequency f can be obtained by setting the straight-edge at the appropriate points on the L and f scales.

Resonance

A straight-edge placed across the L , C and f scales shows the respective values of inductance and capacitance which will resonate at a particular frequency.

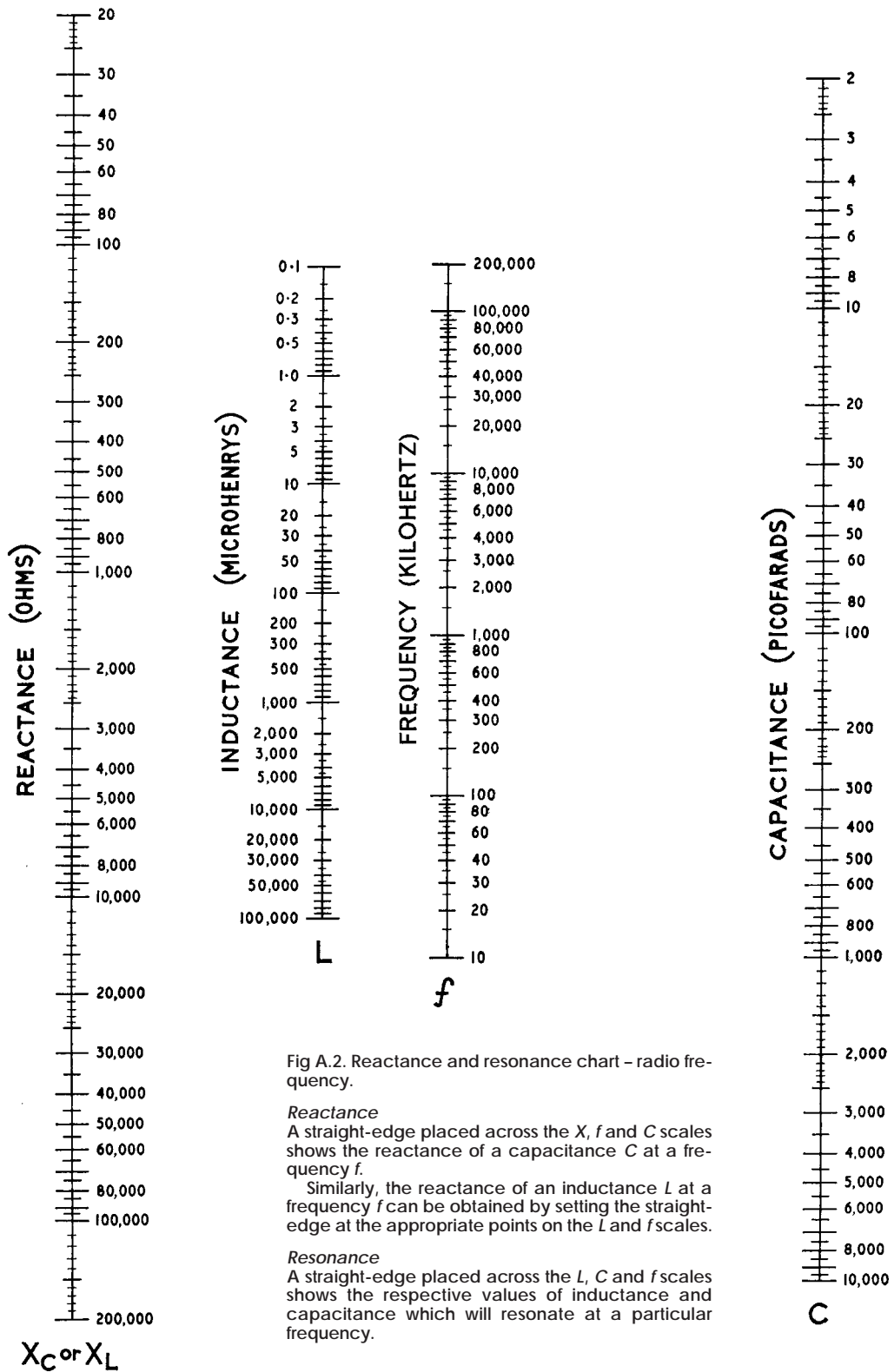

Fig A.2. Reactance and resonance chart - radio frequency.

Reactance

A straight-edge placed across the X , f and C scales shows the reactance of a capacitance C at a frequency f .

Similarly, the reactance of an inductance L at a frequency f can be obtained by setting the straight-edge at the appropriate points on the L and f scales.

Resonance

A straight-edge placed across the L , C and f scales shows the respective values of inductance and capacitance which will resonate at a particular frequency.

FILTER DESIGN CALCULATIONS

Coupling between two resonant circuits tuned to the same frequency [1]

The coupling coefficient is the ratio of the mutual inductance between windings to the inductance of one winding. This is true where the primary and secondary are identical; for simplicity, this is taken to be the case.

When the peak of the response is flat and on the point of splitting, the coupling is at its critical value, which is given by:

$$k_c = \frac{1}{Q} \quad (Q_p = Q_s)$$

Hence, the higher the Q , the lower the coupling required. In an IF transformer, the coupling is set at the critical value; however, for use in wide-band couplers it is convenient to have it slightly higher. The design formulae given below are based on a coupling/critical coupling ratio of 1.86, corresponding to a peak-to-trough ratio of 1.2:1, or a response flat within 2dB over the band.

The most convenient way of introducing variable coupling between two tuned circuits is with a small trimmer between the ‘hot’ ends of the coils (see Fig A.3). This is equivalent, except where phase relationships are concerned, to a mutual inductance of the value:

$$M = \frac{C_1}{C_1 + C} L$$

Hence the coupling coefficient is:

$$k = \frac{C_1}{C_1 + C}$$

The purpose of the damping resistors R in Fig A.3 is to obtain correct circuit Q ; they should not be omitted unless the source or load provides the proper termination.

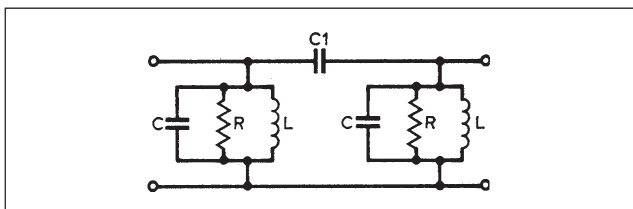

Fig A.3. Basic coupler circuit

Given set values of damping resistance, pass-band and centre frequency, all values may be calculated from the following formulae:

$$k = 0.84 \frac{\text{Bandwidth (kHz)}}{\text{Centre frequency (kHz)}}$$

$$Q = \frac{1.86}{k} \quad L = \frac{R}{2\pi f Q} \quad C = \frac{1}{L} \left(\frac{1}{2\pi f} \right)^2$$

where C is in microfarads, L in microhenrys and f is the centre frequency in megahertz. R is in ohms.

Note that C includes all strays: if the calculated value of C is less than the estimated strays on any band, a lower value of R should be used. The bandswitch can increase the strays to 20pF or more.

Coupling capacitance C_1 is given by:

$$C_1 = \frac{k}{1 - k} C$$

Elliptic filters [1]

Using modern design procedure, a ‘normalised’ filter having the desired performance is chosen from a series of precalculated designs. The following presentation, originally due to W3NQN, uses normalisation to a cut-off frequency of 1Hz and termination resistance of 1Ω , and all that is required to ascertain the constants of a practical filter is to specify the actual cut-off frequency and termination resistance required and to scale the normalised filter data to those parameters.

The following abbreviations are used in these curves:

- A = attenuation (dB),
- A_p = maximum attenuation in pass-band,
- f_4 = first attenuation peak,
- f_2 = second attenuation peak with two-section filter or third attenuation peak with three-section filter,
- f_6 = second attenuation peak with three-section filter,
- f_{co} = frequency where the attenuation first exceeds that in the pass-band,
- A_s = minimum attenuation in stop-band,
- f_s = frequency where minimum stop-band attenuation is first reached.

The attenuation peaks f_4, f_6 or f_2 are associated with the resonant circuits $L4/C4, L6/C6$ and $L2/C2$ on the respective diagrams.

Applications

Because of their low value of reflection coefficient (P) and VSWR, Tables 1-1, 1-2 and 1-3 of Table A.12 and Tables 2-1 to 2-6 inclusive of Table A.13 are best suited for RF applications where power must be transmitted through the filter. The two-section filter has a relatively gradual attenuation slope and the stop-band attenuation level (A_s) is not achieved until a frequency f_s is reached which is two to three times the cut-off frequency. If a more abrupt attenuation slope is desired, then one of the three-section filters (Tables 2-1 to 2-6 in Table A.13) should be used. In these cases the stop-band attenuation level may be reached at a frequency only 1.25 to 2 times f_{co} .

Tables 1-4 to 1-6 of Table A.12 are intended for AF applications where transmission of appreciable power is not required, and consequently the filter response may have a much higher value of VSWR and pass-band ripple without adversely affecting the filter performance. If the higher pass-band ripple is acceptable, a more abrupt attenuation slope is possible. This can be seen by comparing the different values of f_s at 50dB in Tables 1-4, 1-5 and 1-6 which have pass-band ripple peaks of 0.28, 0.50 and 1.0dB respectively. The values of A_s for the audio filters were selected to be between 35 and 55dB, as this range of stop-band attenuation was believed to be optimum for most audio filtering requirements.

It should be noted that *all* C and L tabular data *must be multiplied by a factor of 10^{-3}* .

With one exception, all the C and L tabulated data of each table have a consistent but unequal increase or decrease in value, a characteristic of most computer-derived filter tables. An exception will be noted in Table 1-5, $A_s = 50$, column C1. The original author points out that this is not an error but arose from a minor change necessitated in the original computer program to eliminate unrealisable component values.

How to use the filter tables

After the desired cut-off frequency has been chosen, the frequencies of f_s and the attenuation peaks may be calculated by multiplying their corresponding tabular values by the required cut-off frequency (f_{co}). The component values of the desired

Table A.12. Two-section elliptic-function filters normalised for a cut-off frequency of 1Hz and terminations of 1Ω

REFLECTION COEFFICIENT, VSWR & Ap	As dB	fs Hz	f4 Hz	f2 Hz	C1 Farad	C3 Farad	C5 Farad	C2 Farad	L2 Henry	C4 Farad	L4 Henry
Table 1-1 p = 4% VSWR = 1.08 Ap = 0.0069 dB	70	3.24	3.39	5.42	110.4	235	103.5	4.34	199.0	11.72	187.5
	65	2.92	3.07	4.88	109.6	233	101.0	5.39	197.9	14.67	183.7
	60	2.56	2.68	4.24	108.2	229	96.9	7.20	195.8	19.88	177.3
	55	2.37	2.48	3.90	107.2	227	93.8	8.57	194.3	23.9	172.7
	50	2.13	2.23	3.48	105.5	223	88.6	10.88	192.0	31.0	164.7
Table 1-2 p = 5% VSWR = 1.11 Ap = 0.011 dB	70	3.07	3.22	5.13	118.3	243	110.8	4.73	203	12.78	191.0
	65	2.79	2.92	4.64	117.4	241	108.3	5.82	202	15.82	187.2
	60	2.46	2.57	4.06	116.0	237	104.0	7.67	200	21.2	180.7
	55	2.28	2.39	3.75	115.0	234	100.8	9.07	198.5	25.3	175.9
	50	2.06	2.16	3.36	113.2	230	95.6	11.43	196.0	32.4	168.1
Table 1-3 p = 8% VSWR = 1.17 Ap = 0.028 dB	70	2.79	2.92	4.64	138.4	262	129.6	5.59	210	15.09	196.4
	65	2.56	2.68	4.24	137.4	259	126.9	6.75	208	18.32	192.4
	60	2.28	2.39	3.75	135.9	255	122.4	8.72	206	23.9	185.7
	55	2.06	2.16	3.36	134.2	251	117.4	10.98	204	30.6	178.4
	50	1.887	1.970	3.05	132.2	245	111.8	13.55	201	38.4	170.3
Table 1-4 p = 25% VSWR = 1.67 Ap = 0.28 dB	55	1.701	1.773	2.71	217	317	190.8	18.03	191.5	49.7	162.3
	50	1.556	1.617	2.44	213	306	181.3	22.8	187.3	63.8	151.9
	45	1.440	1.493	2.22	209	295	170.6	28.3	182.7	80.9	140.5
	40	1.325	1.369	1.988	203	279	155.8	36.4	176.0	108.0	125.1
	35	1.236	1.273	1.802	195.9	262	139.2	46.4	168.2	144.3	108.3
Table 1-5 p = 33% VSWR = 2.00 Ap = 0.50 dB	55	1.618	1.690	2.56	248	348	214	21.3	181.4	58.7	151.0
	50	1.481	1.540	2.30	249	336	210	27.4	174.9	76.7	139.3
	45	1.369	1.416	2.08	244	318	197.5	34.7	169.2	99.8	126.5
	40	1.270	1.308	1.878	238	299	177.3	44.4	161.7	133.7	110.8
	35	1.186	1.222	1.700	229	280	163.3	57.0	153.9	177.6	95.5
Table 1-6 p = 45% VSWR = 2.67 Ap = 1.00 dB	55	1.528	1.591	2.39	314	401	276	28.3	156.9	77.5	129.1
	50	1.407	1.459	2.16	308	381	260	35.5	153.3	99.6	119.4
	45	1.245	1.313	1.898	306	365	247	46.6	150.7	135.0	108.9
	40	1.217	1.250	1.755	296	341	227	59.2	138.9	176.2	92.0
	35	1.145	1.174	1.597	284	315	203	75.4	131.6	237	77.7
	As dB	fs Hz	f4 Hz	f2 Hz	L1 Henry	L3 Henry	L5 Henry	L2 Henry	C2 Farad	L4 Henry	C4 Farad

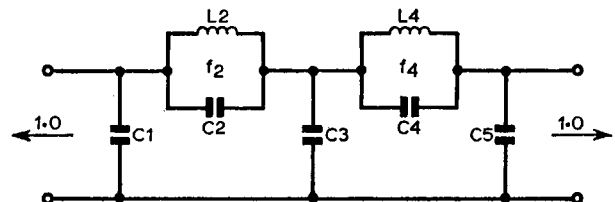
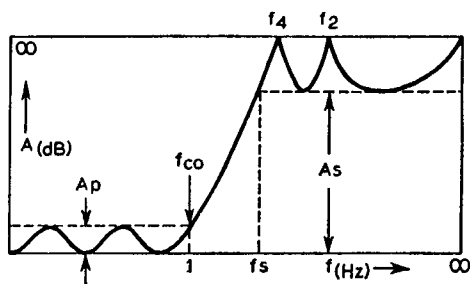

Figure 1 **

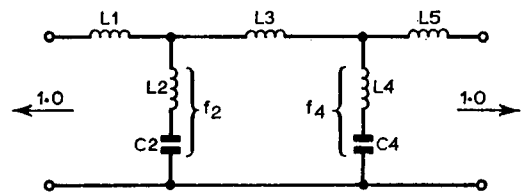

Figure 2 **

* All tabulated data of C and L must be multiplied by 10⁻³; for example, in Table 1-1, the normalized value of C1 is 110.4 x 10⁻³, for As = 70dB

** In the above tabulation, the top column headings pertain to Figure 1 while the bottom column headings pertain to Figure 2

filter are then found by multiplying C and L values in the tables by 1/Rf_{co} and R/f_{co} respectively.

Example 1

A low-pass audio filter to attenuate speech frequencies above 3kHz with a minimum attenuation of 40dB for all frequencies above 3.8kHz, and to be terminated in resistive loads of 1.63kΩ. (This odd value has been chosen merely for convenience in demonstrating the design procedure.)

The circuit of Fig 1 in the Tables is chosen because this has the minimum number of inductors, which are both more

expensive and have higher losses than do capacitors. The parameters are:

$$A_s = 40\text{dB} \quad f_{co} = 3\text{kHz} \quad R = 1.63\text{k}\Omega$$

From Table 1-5 of Table 23.12, A_s = 40dB, calculate f'_s, f'₄ and f'₂. (Numbers with the prime (') are the frequency and component values of the final design: numbers without the prime are from the filter catalogue.)

- (1) f'_s = f_s(f_{co}) = 1.270 x 3 = 3.81kHz
- f'₄ = f₄(f_{co}) = 1.308 x 3 = 3.92kHz
- f'₂ = f₂(f_{co}) = 1.878 x 3 = 5.63kHz

Table A.13. Three-section elliptic-function filters normalised for a cut-off frequency of 1Hz and terminations of 1Ω

REFLECTION COEFFICIENT, VSWR & Ap	As dB	fs Hz	f4 Hz	f6 Hz	f2 Hz	C1 Farad	C3 Farad	C5 Farad	C7 Farad	C2 Farad	L2 Henry	C4 Farad	L4 Henry	C6 Farad	L6 Henry
Table 2-1 p = 1% VSWR = 1.02 Ap = 0.43 x 10 ⁻³ dB	70 64 60 55 50	2.00 1.836 1.743 1.624 1.524	2.04 1.876 1.780 1.657 1.554	2.49 2.27 2.15 1.990 1.854	4.35 3.95 3.72 3.41 3.15	79.6 78.3 77.3 75.8 74.1	209 204 200 194.2 187.8	201 194.8 190.3 183.5 176.3	63.1 58.2 54.5 48.5 41.8	7.42 9.10 10.35 12.42 14.75	180.2 178.4 177.1 175.2 172.8	30.9 38.4 44.1 53.8 65.3	196.4 187.6 181.4 171.4 160.7	26.3 33.0 38.2 47.2 58.0	155.2 148.3 143.5 135.6 127.1
Table 2-2 p = 2% VSWR = 1.04 Ap = 1.7 x 10 ⁻³ dB	70 64 60 55 50	1.836 1.701 1.624 1.524 1.414	1.876 1.737 1.657 1.554 1.440	2.27 2.09 1.990 1.854 1.702	3.95 3.61 3.41 3.15 2.86	93.8 92.5 91.5 89.9 87.5	222 216 212 206 196.9	212 205 200 192.7 182.1	75.7 70.7 67.1 61.1 52.2	8.34 10.08 11.35 13.47 16.70	194.8 193.1 191.6 189.4 186.1	35.8 43.8 49.8 60.0 76.4	201 191.6 185.1 174.8 160.0	29.4 36.2 41.3 50.2 64.8	167.0 160.0 154.8 146.7 135.0
Table 2-3 p = 3% VSWR = 1.06 Ap = 3.9 x 10 ⁻³ dB	70 65 60 55 50	1.743 1.624 1.524 1.440 1.367	1.780 1.657 1.554 1.466 1.391	2.15 1.990 1.854 1.737 1.636	3.72 3.41 3.15 2.92 2.73	104.2 102.8 101.2 99.5 97.6	230 224 217 211 203	219 211 203 194.8 186.2	84.7 79.7 74.1 67.9 61.2	9.06 10.84 12.86 15.12 17.65	203 201 198.3 195.9 193.1	39.7 48.1 57.8 69.0 82.2	201 191.8 181.6 170.8 159.2	31.8 38.7 46.8 56.3 67.5	172.5 165.4 157.5 149.1 140.1
Table 2-4 p = 4% VSWR = 1.08 Ap = 6.9 x 10 ⁻³ dB	70 65 60 55 50	1.701 1.589 1.494 1.414 1.325	1.737 1.621 1.523 1.440 1.347	2.09 1.942 1.813 1.702 1.576	3.61 3.32 3.07 2.86 2.61	113.0 111.6 110.0 108.3 105.6	236 230 224 217 206	224 217 208 199.6 187.5	93.0 88.0 82.4 76.3 67.3	9.37 11.18 13.20 15.47 18.94	208 205 203 201 196.9	41.6 50.2 60.0 71.4 89.7	202 192.3 181.9 171.1 155.6	32.7 39.6 47.6 57.0 72.2	177.0 170.0 161.9 153.4 141.3
Table 2-5 p = 5% VSWR = 1.11 Ap = 11 x 10 ⁻³ dB	70 65 60 55 51.5 50	1.662 1.556 1.466 1.367 1.325 1.305	1.696 1.586 1.494 1.391 1.347 1.327	2.04 1.897 1.774 1.636 1.576 1.548	3.51 3.23 3.00 2.73 2.61 2.55	120.6 119.2 117.6 115.2 113.8 113.1	242 235 228 219 213 211	229 221 212 199.7 193.4 190.2	99.9 94.9 89.3 81.0 76.5 74.1	9.77 11.61 13.67 16.81 18.57 19.51	211 209 206 203 201 199.7	43.9 52.7 62.8 78.8 88.2 93.2	201 191.1 180.8 166.2 158.3 154.4	33.9 40.9 49.0 61.9 69.5 73.7	179.4 172.0 164.1 152.7 146.6 143.5
Table 2-6 p = 8% VSWR = 1.17 Ap = 28 x 10 ⁻³ dB	70 65 60 55 50	1.556 1.466 1.390 1.325 1.252	1.586 1.494 1.415 1.347 1.271	1.897 1.774 1.668 1.576 1.471	3.23 3.00 2.79 2.61 2.39	139.7 138.1 136.3 134.4 131.4	252 245 238 230 218	237 228 218 208 193.9	116.2 110.9 105.0 98.6 89.2	11.30 13.30 15.54 18.05 21.9	214 212 210 207 202	52.0 61.9 73.2 86.3 107.3	193.4 183.5 173.0 161.9 146.1	39.1 46.6 55.3 65.4 81.6	180.0 172.5 164.4 155.8 143.4
	As dB	fs Hz	f4 Hz	f6 Hz	f2 Hz	L1 Henry	L3 Henry	L5 Henry	L7 Henry	L2 Henry	C2 Farad	L4 Henry	C4 Farad	L6 Henry	C6 Farad

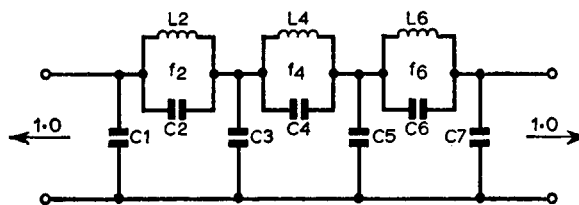
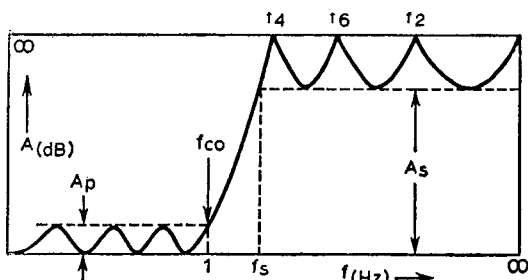

Figure 1 **

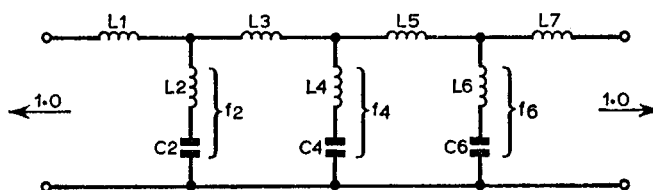

Figure 2 **

* All tabulated data of C and L must be multiplied by 10⁻³; for example, in Table 2-1, the normalized value of C1 is 79.6 x 10⁻³, for As = 70dB

** In the above tabulation, the top column headings pertain to Figure 1 while the bottom column headings pertain to Figure 2

(2) Calculate factors 1/Rf_{co} and Rf_{co} to determine the capacitor and inductor values.

$$1/Rf_{co} = 1/(1.63 \times 10^3) (3 \times 10^3) = 1/(4.89 \times 10^6) = 0.2045 \times 10^{-6}$$

$$Rf_{co} = (1.63 \times 10^3)/(3 \times 10^3) = 0.543$$

(3) Calculate the component values of the desired filter by multiplying all the catalogue tabular values of C by 1/Rf_{co} and L by Rf_{co} as shown below:

$$C'1 = C1(1/Rf_{co}) = (238 \times 10^{-3}) (0.2045) 10^{-6} = 0.0487\mu F$$

$$C'3 = C3(1/Rf_{co}) = (299 \times 10^{-3}) (0.2045) 10^{-6} = 0.0612\mu F$$

$$C'5 = C5(1/Rf_{co}) = (177.3 \times 10^{-3}) (0.2045) 10^{-6} = 0.0363\mu F$$

$$C'2 = C2(1/Rf_{co}) = (44.4 \times 10^{-3}) (0.2045) 10^{-6} = 0.00908\mu F$$

$$C'4 = C4(1/Rf_{co}) = (133.7 \times 10^{-3}) (0.2045) 10^{-6} = 0.00273\mu F$$

$$L'2 = L2(Rf_{co}) = (161.7 \times 10^{-3}) (0.543) = 87.8mH$$

$$L'4 = L4(Rf_{co}) = (110.8 \times 10^{-3}) (0.543) = 60.1mH$$

These calculations, which may conveniently be performed with a pocket calculator, complete the design of the filter.

It should be noted that all the elliptic-function data is based

Table A.14. Butterworth filters

K	C ₁ L ₁	C ₂ L ₂	C ₃ L ₃	C ₄ L ₄	C ₅ L ₅	C ₆ L ₆	C ₇ L ₇	C ₈ L ₈	C ₉ L ₉	C ₁₀ L ₁₀
1	2.000	—	—	—	—	—	—	—	—	—
2	1.4142	1.4142	—	—	—	—	—	—	—	—
3	1.000	2.000	1.000	—	—	—	—	—	—	—
4	0.7654	1.8478	1.8478	0.7654	—	—	—	—	—	—
5	0.6180	1.6180	2.000	1.6180	0.6180	—	—	—	—	—
6	0.5176	1.4142	1.9319	1.9319	1.4142	0.5176	—	—	—	—
7	0.4450	1.2470	1.8019	2.000	1.8019	1.2470	0.4450	—	—	—
8	0.3902	1.1111	1.6629	1.9616	1.9616	1.6629	1.1111	0.3902	—	—
9	0.3473	1.000	1.5321	1.8794	2.000	1.8794	1.5321	1.000	0.3473	—
10	0.3129	0.9080	1.4142	1.7820	1.9754	1.9754	1.7820	1.4142	0.9080	0.3129

on the use of lossless components and purely resistive terminations. Therefore components of the highest possible *Q* should be used and precautions taken to ensure that the filter is properly terminated.

It will be noticed that some rather curious values of both capacitance and inductance may emerge from the calculations but these may be rationalised to the extent that the tolerance on the values of components need not be closer than some ±3%.

Example 2

A three-section low-pass filter to suppress harmonics at the output of a transmitter covering the HF bands up to a frequency of 30MHz with a matching impedance of 50Ω and a minimum attenuation in the stop-band of 50dB.

The parameters are, from Table 2-2 (circuit Fig 2) of Table A.13:

$$A_s = 50\text{dB} \quad f_{co} = 30\text{MHz} \quad R = 50\Omega$$

From Table 2-2 (bottom line) of Table A.13, calculate f'_s, f'_4, f'_6 and f'_2 .

- (1) $f'_s = f_s(f_{co}) = 1.414 \times 30 = 42.4\text{MHz}$
 $f'_4 = f_4(f_{co}) = 1.440 \times 30 = 43.2\text{MHz}$
 $f'_6 = f_6(f_{co}) = 1.702 \times 30 = 51\text{MHz}$
 $f'_2 = f_2(f_{co}) = 2.860 \times 30 = 85.8\text{MHz}$

- (2) Calculate factors $1/Rf_{co}$ and R/f_{co} to determine the capacitor and inductor values respectively.

$$1/Rf_{co} = 1/50(30 \times 10^6) = 66 \times 10^{-11}$$

$$R/f_{co} = 50/(30 \times 10^6) = 1.67 \times 10^{-6}$$

- (3) Calculate component values of the desired filter by multiplying all tabular values of C by $1/Rf_{co}$ and L by R/f_{co} , remembering to multiply all values in the tables by 10^{-3} .

$$C'2 = C2(66 \times 10^{-11}) \quad L'1 = L1(1.67 \times 10^{-6})$$

$$= (186.1 \times 10^{-3})(66 \times 10^{-11}) \quad = (87.5 \times 10^{-3})(1.67 \times 10^{-6})$$

$$= 12,286.6 \times 10^{-14}\text{F} \quad = 146.1 \times 10^{-9}\text{H}$$

$$= 12,282.6 \times 10^{-2}\text{pF} \quad = 0.15\mu\text{H}$$

$$= 122.8\text{pF}$$

$$C'4 = (160 \times 10^{-3})(66 \times 10^{-11}) \quad L'2 = 0.03\mu\text{H} \quad L'3 = 0.33\mu\text{H}$$

$$= 105.6\text{pF} \quad L'4 = 0.13\mu\text{H} \quad L'5 = 0.30\mu\text{H}$$

$$C'6 = 89.1\text{pF} \quad L'6 = 0.11\mu\text{H} \quad L'7 = 0.09\mu\text{H}$$

As a check, it will be found that the combination C4, L4 tunes to 43.2MHz and that the other two series-tuned circuits tune to the other two points of maximum attenuation previously specified.

In order to convert the values in the filter just designed to match an impedance of 75Ω it is only necessary to multiply all values of capacitance by 2/3 and all values of inductance by 3/2. Thus C6 and L6 in a 75Ω filter become approximately 59.4pF and 0.17μH respectively.

Butterworth filters [1]

Frequency response curve:

$$A = 10 \log_{10} \left[1 + \left(\frac{f}{f_c} \right)^{2K} \right]$$

where *A* is the attenuation, *f* is the frequency for an insertion loss of 3.01dB, and *K* is the number of circuit elements.

Low- and high-pass filters

Table A.14 is for normalised element values of *K* from 1 to 10 (number of sections) reduced to 1Ω source and load resistance (zero reactance) and a 3.01dB cut-off frequency of 1 radian/s (0.1592Hz). In both low-pass and high-pass filters:

$$L = \frac{R}{2\pi f_c} = L \text{ (1}\Omega/\text{radian)} \quad C = \frac{1}{2\pi f_c R} = C \text{ (1}\Omega/\text{radian)}$$

where *R* is the load resistance in ohms and f_c is the desired 3.01dB frequency (Hz).

An example of a Butterworth low-pass filter is given in Fig A.4 (see Table A.14 for element values). In these examples of five-element filters (a) has a shunt element next to the load and (b) has a series element next to the load. Either filter will have the same response. In the examples of five-element filters given in Fig A.5, (a) has a series element next to the load and (b) has a shunt element next to the load. Either filter will have the same response.

Butterworth band-pass filters

Centre frequency $f_0 = \sqrt{f_1 f_2}$

Bandwidth $BW = f_2 - f_1$

If the bandwidth specified is not the 3.01dB bandwidth (*BW_c*), the latter can be determined from:

$$BW_c = \frac{BW}{(10^{0.1A} - 1)/2K}$$

where *A* is the required attenuation at cut-off frequencies.

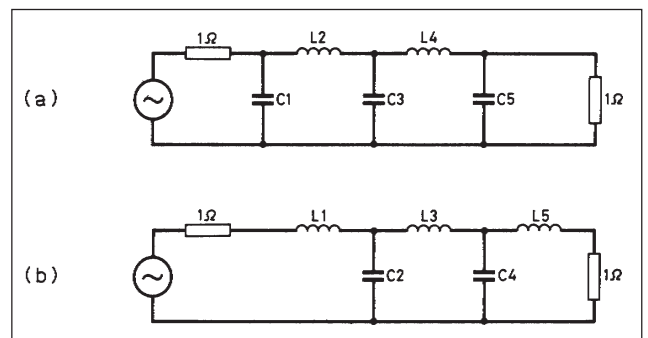

Fig A.4. Butterworth low-pass filter

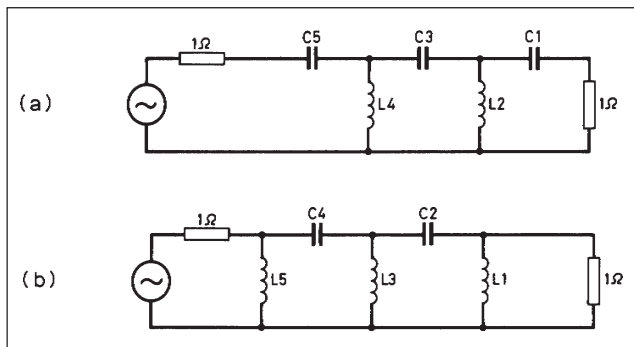

Fig A.5. Butterworth high-pass filter

Lower cut-off frequency:

$$f_{cl} = \frac{-BW_c + \sqrt{(BW_c)^2 + 4f_0^2}}{2}$$

Upper cut-off frequency: $f_{cu} = f_{cl} + BW_c$

An alternative, more-convenient method, is to choose a 3.01dB bandwidth (as wide as possible) around the desired centre frequency and compute the attenuation at other frequencies of interest by using the transformation:

$$\frac{f}{f_c} = \left[\left(\frac{f}{f_0} - \frac{f_0}{f} \right) \frac{f_0}{BW_c} \right]$$

Chebyshev filters [1]

Tables A.15 to A.18 provide the essential information for both high-pass and low-pass filters of T and π form. Figures are given for pass-band ripples of 1, 0.1, 0.01, and 0.001dB which respectively correspond to VSWR of 2.66, 1.36, 1.10 and 1.03.

The filters in this case are normalised to a frequency of 1MHz and an input and output impedance of 50Ω. This means that for any particular desired frequency the component values simply have to be divided by the required frequency in megahertz.

The 1MHz is the cut-off frequency; attenuation increases rapidly above the frequency for a low-pass filter and correspondingly below for a high-pass type.

The filter data is also dependent on the impedance which as given is for 50Ω. For other impedances the component values need to be modified by the following:

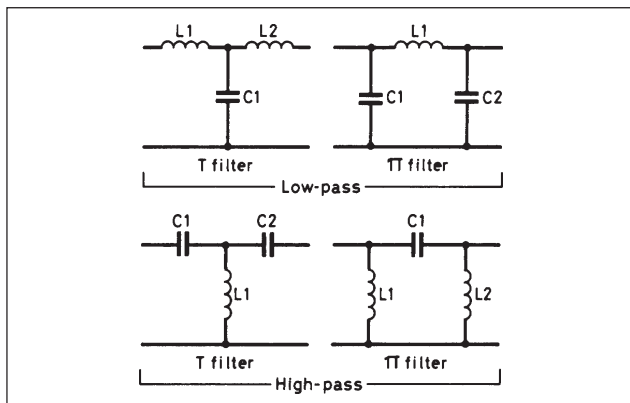

Fig A.6. Single-section three-pole filter elements

$$\frac{Z_n}{50} \text{ for inductors} \qquad \frac{50}{Z_n} \text{ for capacitors}$$

where Z_n is the required impedance.

There is an advantage in using toroidal-form inductors due to their self-screening (confined-field) properties. Mica or silver mica capacitors are superior to other types for filter applications.

Practical filters for the amateur HF bands are given in Table A.19.

Constant-*k* and *m*-derived filters [2]

The filter sections shown in Fig A.7 can be used alone or, if greater attenuation and sharper cut-off is required, several sections can be connected in series. In the low-pass and high-pass filters, f_c represents the cut-off frequency, the highest (for the low-pass) or the lowest (for the high-pass) frequency transmitted without attenuation. In the band-pass filter designs, f_1 is the low-frequency cut-off and f_2 the high-frequency cut-off. The units for L , C , R and f are henrys, farads, ohms and hertz respectively.

All the types shown are for use in an unbalanced line (one side grounded), and thus they are suitable for use in coaxial line or any other unbalanced circuit. To transform them for balanced lines (eg 300Ω transmission line or push-pull audio circuits), the series reactances should be equally divided between the two legs. Thus the balanced constant- k π-section low-pass filter

Table A.15. Chebyshev low-pass filter ('T' configuration)

	Ripple (dB)	L_1	L_2	L_3	L_4	L_5	C_1	C_2	C_3	C_4
Single section (3-pole)	1	16.10	16.10	—	—	—	3164.3	—	—	—
	0.1	8.209	8.209	—	—	—	3652.3	—	—	—
	0.01	5.007	5.007	—	—	—	3088.5	—	—	—
	0.001	3.253	3.253	—	—	—	2312.6	—	—	—
Two-section (5-pole)	1	16.99	23.88	16.99	—	—	3473.1	3473.1	—	—
	0.1	9.126	15.72	9.126	—	—	4364.7	4364.7	—	—
	0.01	6.019	12.55	6.019	—	—	4153.7	4153.7	—	—
	0.001	4.318	10.43	4.318	—	—	3571.1	3571.1	—	—
Three-section (7-pole)	1	17.24	24.62	24.62	17.24	—	3538.0	3735.4	3538.0	—
	0.1	9.40	16.68	16.68	9.40	—	4528.9	5008.3	4528.9	—
	0.01	6.342	13.91	13.91	6.342	—	4432.2	5198.4	4432.2	—
	0.001	4.69	12.19	12.19	4.69	—	3951.5	4924.1	3981.5	—
Four-section (9-pole)	1	17.35	24.84	25.26	24.84	17.35	3562.5	3786.9	3786.9	3562.5
	0.1	9.515	16.99	17.55	16.99	9.515	4591.9	5146.2	5146.2	4591.9
	0.01	6.481	14.36	15.17	14.36	6.481	4542.5	5451.2	5451.2	4542.5
	0.001	4.854	12.81	13.88	12.81	4.854	4108.2	5299.0	5299.0	4108.2

Inductance in microhenrys, capacitance in picofarads. Component values normalised to 1MHz and 50Ω.

Table A.16. Chebyshev low-pass filter (Pi configuration)

	Ripple (dB)	C_1	C_2	C_3	C_4	C_5	L_1	L_2	L_3	L_4
Single section (3-pole)	1	6441.3	6441.3	—	—	—	7.911	—	—	—
	0.1	3283.6	3283.6	—	—	—	9.131	—	—	—
	0.01	2007.7	2007.7	—	—	—	7.721	—	—	—
	0.001	1301.2	1301.2	—	—	—	5.781	—	—	—
Two-section (5-pole)	1	6795.5	9552.2	6795.5	—	—	8.683	8.683	—	—
	0.1	3650.4	6286.6	3650.4	—	—	10.91	10.91	—	—
	0.01	2407.5	5020.7	2407.5	—	—	10.38	10.38	—	—
	0.001	1727.3	4170.5	1727.3	—	—	8.928	8.928	—	—
Three-section (7-pole)	1	3538	5052	5052	3538	—	17.24	18.20	17.24	—
	0.1	3759.8	6673.9	6673.9	3759.8	—	11.32	12.52	11.32	—
	0.01	2536.8	5564.5	5564.5	2536.8	—	11.08	13.00	11.08	—
	0.001	1875.7	4875.9	4875.9	1875.7	—	9.879	12.31	9.879	—
Four-section (9-pole)	1	6938.3	9935.8	10,105	9935.8	6938.3	8.906	9.467	9.467	8.906
	0.1	3805.9	6794.5	7019.9	6794.5	3805.9	11.48	12.87	12.87	11.48
	0.01	2592.5	5743.5	6066.3	5743.5	2592.5	11.36	13.63	13.63	11.36
	0.001	1941.7	5124.6	5553.2	5124.6	1941.7	10.27	13.25	13.25	10.27

Inductance in microhenrys, capacitance in picofarads. Component values normalised to 1MHz and 50Ω.

Table A.17. Chebyshev high-pass filter ('T' configuration)

	Ripple (dB)	C_1	C_2	C_3	C_4	C_5	L_1	L_2	L_3	L_4
Single section (3-pole)	1	1573	1573	—	—	—	8.005	—	—	—
	0.1	3085.7	3085.7	—	—	—	6.935	—	—	—
	0.01	5059.1	5059.1	—	—	—	8.201	—	—	—
	0.001	7786.9	7786.9	—	—	—	10.95	—	—	—
Two-section (5-pole)	1	1491	1060.7	1491	—	—	7.293	7.293	—	—
	0.1	2775.6	1611.7	2775.6	—	—	5.803	5.803	—	—
	0.01	4208.6	2018.6	4208.6	—	—	6.098	6.098	—	—
	0.001	5865.7	2429.5	5865.7	—	—	7.093	7.093	—	—
Three-section (7-pole)	1	1469.2	1028.9	1028.9	1469.2	—	7.160	6.781	7.160	—
	0.1	2694.9	1518.2	1518.2	2694.9	—	5.593	5.058	5.593	—
	0.01	3994.1	1820.9	1820.9	3994.1	—	5.715	4.873	5.715	—
	0.001	5401.7	2078	2078	5401.7	—	6.410	5.144	6.410	—
Four-section (9-pole)	1	1460.3	1019.8	1002.7	1019.8	1460.3	7.110	6.689	6.689	7.110
	0.1	2662.2	1491.2	1443.3	1491.2	2662.2	5.516	4.922	4.922	5.516
	0.01	3908.2	1764.1	1670.2	1764.1	3908.2	5.578	4.647	4.647	5.578
	0.001	5216.3	1977.1	1824.6	1977.1	5216.3	6.657	4.780	4.780	6.657

Inductance in microhenrys, capacitance in picofarads. Component values normalised to 1MHz and 50Ω.

Table A.18. Chebyshev high-pass filter (Pi configuration)

	Ripple (dB)	L_1	L_2	L_3	L_4	L_5	C_1	C_2	C_3	C_4
Single section (3-pole)	1	3.932	3.932	—	—	—	3201.7	—	—	—
	0.1	7.714	7.714	—	—	—	2774.2	—	—	—
	0.01	12.65	12.65	—	—	—	3280.5	—	—	—
	0.001	19.47	19.47	—	—	—	4381.4	—	—	—
Two-section (5-pole)	1	3.727	2.652	3.727	—	—	2917.3	2917.3	—	—
	0.1	6.939	4.029	6.939	—	—	2321.4	2321.4	—	—
	0.01	10.52	5.045	10.52	—	—	2439.3	2439.3	—	—
	0.001	14.66	6.074	14.66	—	—	2837.3	2837.3	—	—
Three-section (7-pole)	1	7.159	5.014	5.014	7.159	—	1469.2	1391.6	1469.2	—
	0.1	8.737	3.795	3.795	8.737	—	2237.2	2023.1	2237.2	—
	0.01	9.985	4.552	4.552	9.985	—	2286.0	1949.1	2286.0	—
	0.001	13.50	5.195	5.195	13.50	—	2584.1	2057.7	2584.1	—
Four-section (9-pole)	1	3.651	2.549	2.507	2.549	3.651	2844.1	2675.6	2675.6	2844.1
	0.1	6.656	3.728	3.608	3.728	6.656	2206.5	1968.9	1968.9	2206.5
	0.01	9.772	4.410	4.176	4.410	9.772	2230.5	1858.7	1858.7	2230.5
	0.001	13.05	4.943	4.561	4.943	13.05	2466.3	1911.8	1911.8	2466.3

Inductance in microhenrys, capacitance in picofarads. Component values normalised to 1MHz and 50Ω.

would use two inductances of a value equal to $L_k/2$, while the balanced constant- k π -section high-pass filter would use two capacitors of a value equal to $2C_k$.

If several low- (or high-) pass sections are to be used, it is advisable to use m -derived end sections on either side of a constant- k section, although an m -derived centre section can be used.

Table A.19. Practical Chebyshev low-pass filters (3-section, 7-pole)

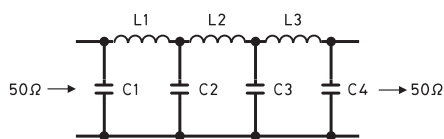

Amateur band	28	21	14	7	3.5	1.8	MHz
F_c	30.9	21.69	15.16	7.98	4.11	2.05	MHz
VSWR	1.10	1.06	1.09	1.08	1.07	1.09	
C1, C4	82	100	160	300	560	1200	pF
C2, C3	180	240	360	680	1300	2700	pF
L1, L3	0.36	0.49	0.72	1.37	2.62	5.42	μ H
L2	0.42	0.59	0.85	1.62	3.13	6.41	μ H

Ripple is 0.01dB.

The factor m relates the ratio of the cut-off frequency and f_∞ , a frequency of high attenuation. Where only one m -derived section is used, a value of 0.6 is generally used for m , although a deviation of 10 or 15% from this value is not too serious in amateur work. For a value of $m = 0.6$, f will be $1.25f_c$ for the low-pass filter and $0.8f_c$ for the high-pass filter. Other values can be found from:

$$m = \sqrt{1 - \left(\frac{f_c}{f_\infty}\right)^2}$$

for the low-pass filter and:

$$m = \sqrt{1 - \left(\frac{f_\infty}{f_c}\right)^2}$$

for the high-pass filter.

The filters shown should be terminated in a resistance R , and there should be little or no reactive component in the termination.

Microstrip circuit elements [3, 4]

In the calculation of microstrip circuit elements it is necessary to establish the dielectric constant for the material. This can be done by measuring the capacitance of a typical sample.

$$\text{Dielectric constant } e = \frac{113 \times C \times h}{a}$$

where C is in picofarads, h is the thickness in millimetres and a is the area in square millimetres. This should be done with a sample about 25mm square to minimise the effects of the edges. Having found the dielectric constant, it is now necessary to calculate the characteristic impedance (Z_0) of the microstrip. There are many approximations for this but the following is simple and accurate enough ($\pm 5\%$) for amateur use since microstrip is fairly forgiving of small errors:

$$Z_0 = \frac{131}{\sqrt{(e + 0.47)}} \times \log_{10} \left(\frac{13.5h}{w} \right)$$

where e is the dielectric constant, h is the dielectric thickness (see Fig 23.8), and w is the conductor width. Note that h and w must be in the same units, eg both in centimetres. The formula assumes that the conductor is thin relative to the dielectric.

An accurate plot of Z_0 against w/h for dielectric constants between 2 (approximately that of PTFE) through 4 (approx that of epoxy-glassfibre) to 6 is given in Fig A.9. The next operation is to determine the velocity factor, the ratio of the velocity of electromagnetic waves in the dielectric to that in free space. Here, too, the equations are complex but the factor only changes slowly as w/h changes. Fig 23.10 gives figures for the above range of dielectric constants.

A microstrip resonator has the form of a strip on one side of a double-sided PCB with the other side as a ground plane. It is usually a quarter-wavelength long. The length is calculated from the free space length multiplied by the velocity factor as estimated above. The line width depends on the required Z_0 and a starting point for experiment would be 50–100 Ω . If it is necessary to tune the resonator accurately, it should be made shorter

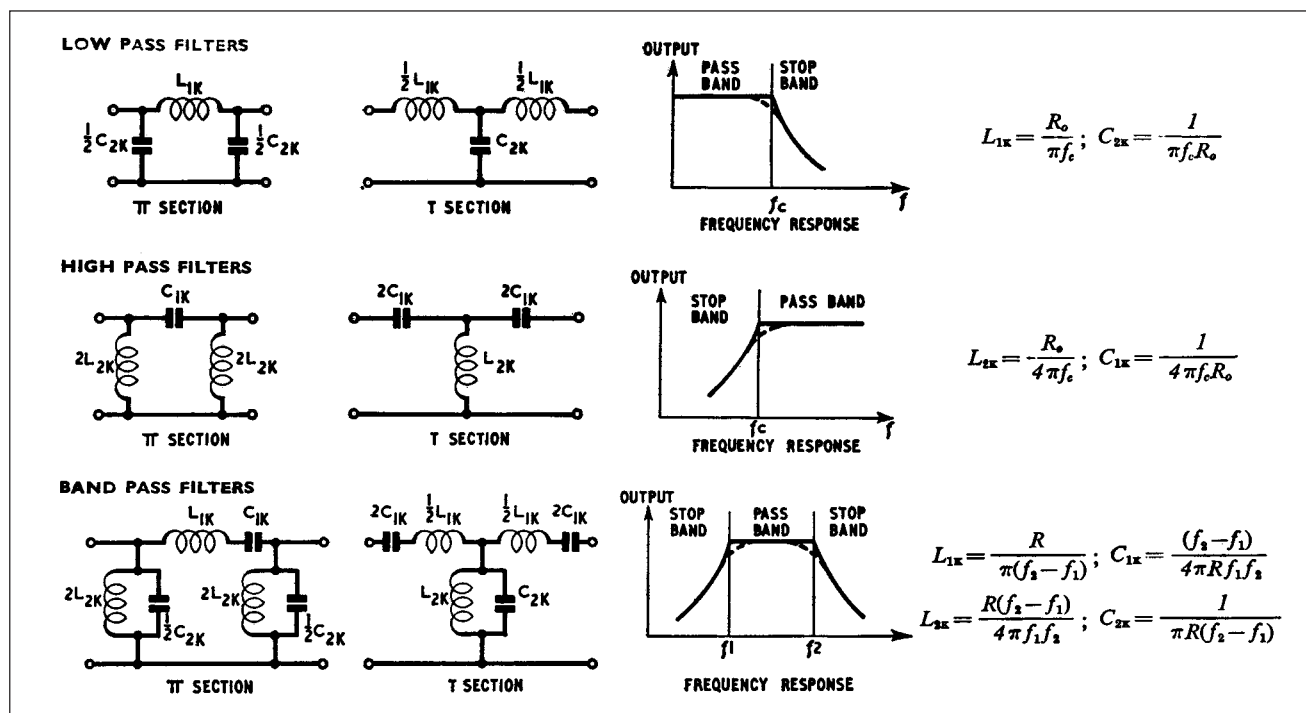

Fig A.7(a). Constant-k filters

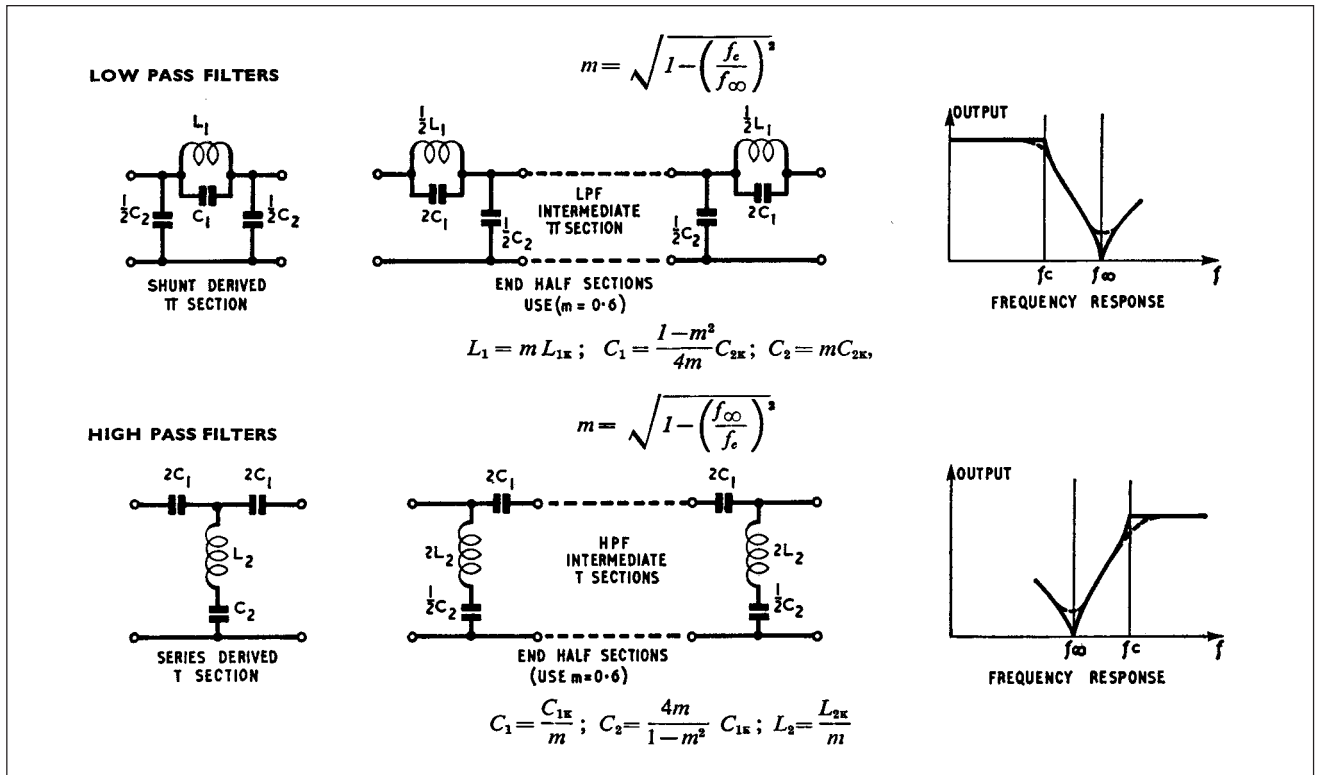

Fig A.7(b). *m*-derived filters

than calculated above and a trimmer capacitor connected between the ‘hot’ end and the ground plane. The new length can be calculated from:

$$l = 0.0028\lambda \times \tan^{-1} \left(\frac{\lambda}{0.188CZ_0} \right)$$

where *l* is the length in centimetres, λ is the wavelength in centimetres, *C* is the capacitance (say at half maximum) in picofarads, Z_0 is the characteristic impedance in ohms and $\tan^{-1}(*)$ is the angle in degrees of which * is the tangent. * represents the figures in the bracket.

Coupling into and out of the line may be directly via tapping(s) or by additional line(s) placed close to the tuned line. A spacing of one line width and a length of 10–20% of the tuned line would be a starting point for experiment.

Materials

The most-used material for amateur purposes is glassfibre reinforced epoxy double-sided PCB. It has a dielectric constant of 4.0–4.5, depending on the resin used. Accurate lines may be made by scoring through the copper carefully with a scalpel or modelling knife and lifting the unwanted copper foil after heating it with a soldering iron to weaken the bond to the plastic.

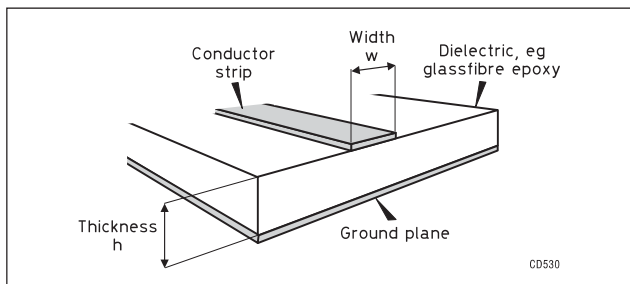

Fig A.8. Dimensions involved in calculating the characteristic impedance of microstrip

For microwave use, glassfibre-reinforced PTFE with a dielectric constant close to 2.5 is the preferred material. Further information is given in the *Microwave Handbook* [4].

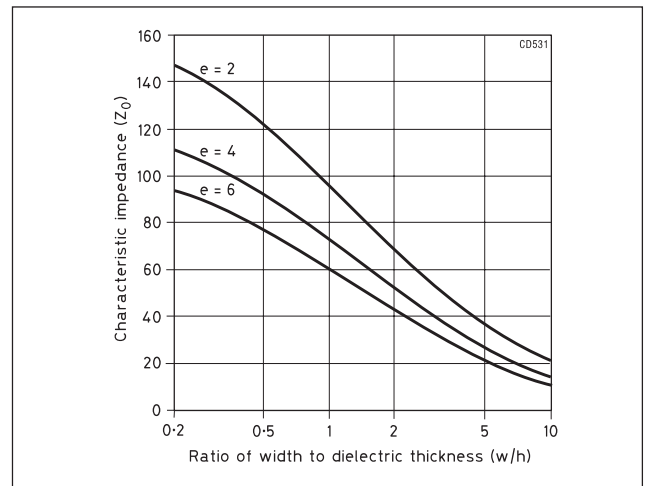

Fig A.9. Characteristic impedance versus *w/h* for dielectric constants between 2 and 6

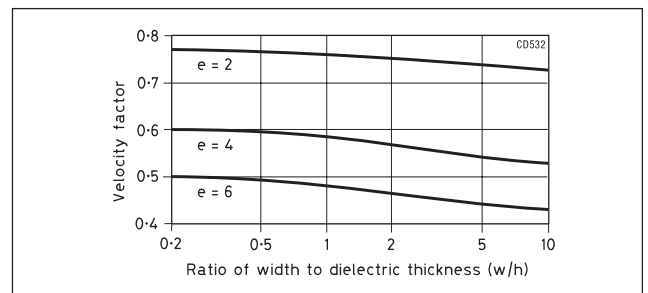

Fig A.10. Velocity factor versus *w/h* for dielectric constants between 2 and 6

Op-amp-based active filters [5]

Design information (taken, by permission, from reference [5]) will be given for four common filter configurations. All are based on inexpensive op-amps such as the 741 and 301A (or their duals or quads in one package) which are adequate when frequencies are in the voice range, insertion gain is between unity and two (0–6dB), signal input and output voltages are in the range between a few millivolts and a few volts, and signal (input, feedback and output) currents between a microamp and a milliamp. This covers the bulk of common amateur applications. No DC supplies to the op-amps are shown.

2nd order ‘Sallen and Key’ Butterworth low-pass filter

Referring to Fig 23.11, the cut-off (–3dB) frequency f_c is:

$$f_c = \frac{1}{2\pi\sqrt{(R_1R_2C_1C_2)}}$$

Choosing ‘equal components’, meaning $R_1 = R_2 = R$ and $C_1 = C_2 = C$, then:

$$f_c = \frac{1}{2\pi RC}$$

For a second-order Butterworth response, the pass-band gain *must* be 4dB or $\times 1.586$. This is achieved by making $(R_A + R_B)/R_A = 1.586$. This is implemented with sufficient accuracy with 5% standard-value resistors of $R_A = 47k\Omega$ and $R_B = 27k\Omega$. This means that a 1V input generates an output of 1.586V at a frequency in the pass-band and $0.707 \times 1.586 = 1.12V$ at the –3dB cut-off frequency; the roll-off above f_c is 12dB/octave or 20dB/decade.

Example. Design a two-pole ‘equal component’ Butterworth low-pass filter (Fig 23.12) with $f_c = 2700Hz$.

Choosing for C a convenient value of 1nF and solving:

$$R = \frac{1}{2\pi f_c C} = 59k\Omega$$

This can be made up from 56k Ω and 2.7k Ω in series.

Should R come out below 10k Ω , choose a larger C; if R would be larger than 100k Ω , select a smaller C; then recalculate R.

The multiple-feedback bandpass filter

Providing two feedback paths to a single op-amp, a band-pass filter can be made with Q up to 10. To get reasonably steep roll-off at low Q, from two to four identical sections (Fig 23.14) are cascaded. The centre frequency is given by:

$$f_0 = \frac{1}{2\pi C} \sqrt{\frac{1}{R_3} \cdot \frac{R_1 + R_2}{R_1 R_2}}$$

for which the three resistors can be calculated from:

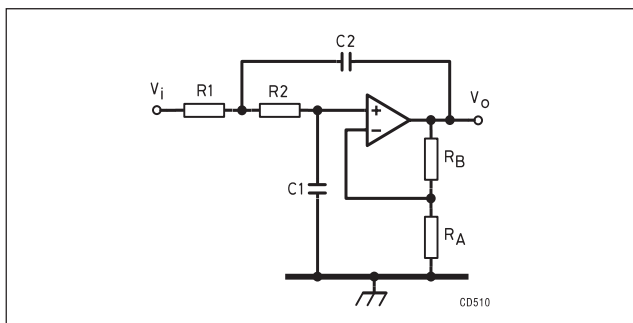

Fig A.11. ‘Sallen & Key’ Butterworth low-pass filter

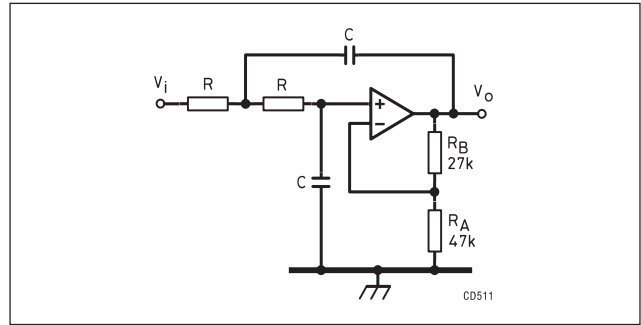

Fig A.12. Equal-component low-pass filter

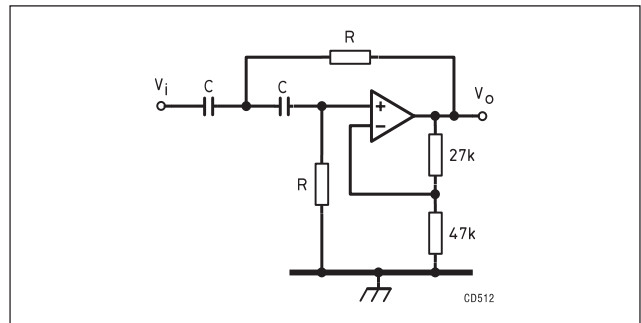

Fig A.13. Equal component high-pass filter

$$R_1 = \frac{Q}{2\pi f_0 G_0 C}$$

$$R_2 = \frac{Q}{2\pi f_0 C(2Q^2 - G_0)}$$

$$R_3 = \frac{Q}{\pi f_0 C}$$

The equations for R_1 and R_3 combine into:

$$G_0 = R_3/2R_1$$

Also, the denominator in the formula for R_2 yields:

$$Q > \sqrt{(G_0/2)}$$

Example. Design a band-pass filter with centre frequency 800Hz, –6dB bandwidth of 200Hz and centre-frequency gain of 2.

A two-section filter, with each section having a 200Hz –3dB bandwidth, is indicated.

$$Q = 800/200 = 4$$

$$G_0 = \sqrt{2} = 1.4$$

Select a convenient C, say 10nF.

$$R_1 = \frac{4}{6.28 \times 800 \times 1.4 \times 10^{-8}}$$

$$= 56.9k\Omega, \text{ (use } 56k\Omega)$$

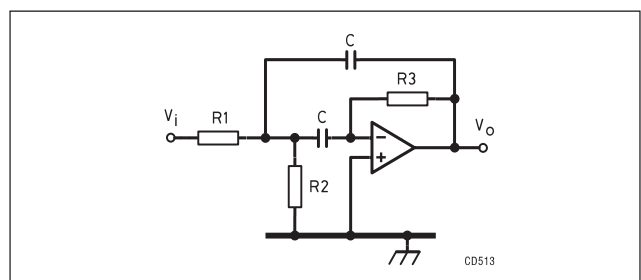

Fig A.14. Multiple-feedback band-pass filter

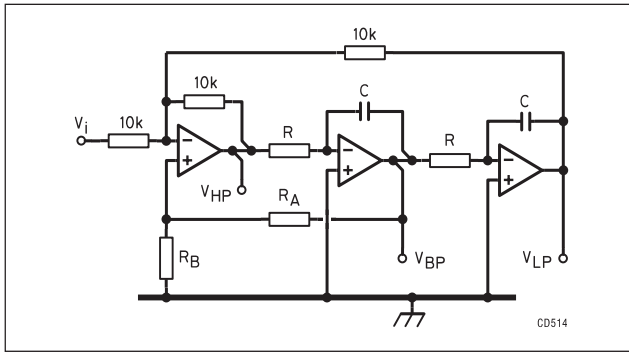

Fig A.15. State-variable filter

$$R_3 = 2 \times 56.9 \times 1.4 = 159\text{k}\Omega \text{ (use } 100\text{k}\Omega + 56\text{k}\Omega)$$

$$R_2 = \frac{4}{6.28 \times 800 \times 10^{-8} \times (2 \times 4^2 - 1.4)} = 2.60\text{k}\Omega \text{ (use } 5.1\text{k}\Omega \text{ in parallel with } 5.1\text{k}\Omega)$$

Note that the centre frequency can be shifted up or down at constant bandwidth and centre frequency gain by changing R_2 only, using ganged variable resistors for cascaded sections:

$$R_2' = R_2 \left(\frac{f_0}{f_0'} \right)^2$$

The state-variable or ‘universal’ filter

Three op-amps, connected as shown in Fig 23.15, can simultaneously provide second-order high-pass, low-pass and band-pass responses. The filter is composed of a difference amplifier and two integrators. The common cut-off/centre frequency is given by:

$$f_{cl} = f_{ch} = f_0 = \frac{1}{2\pi RC}$$

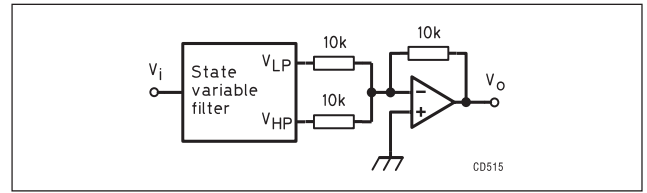

Fig A.16. Using the state-variable filter to obtain a notch response

The filter’s Q depends only on R_A and R_B :

$$R_A = (3Q - 1)R_B$$

There is no way to simultaneously optimise the performance of high-/low-pass and band-pass performance. For a Butterworth response, Q must be 0.7 and even for a second-order 3dB-ripple Chebyshev response the Q is no more than 1.3, obviously too low for good band-pass response. No DC voltage should be applied to the input of this filter and there should be no significant DC load on its outputs.

By adding the low-pass and high-pass outputs from a variable-state filter in a summing amplifier, a notch response is obtained. See Fig 23.16.

For an application of the variable-state filter refer to the active filters section in Chapter 5 and Fig 5.108 in particular.

REFERENCES

- [1] *Radio Data Reference Book*, 5th edn, G R Jessop, G6JP, RSGB, 1985.
- [2] *ARRL Radio Amateur’s Handbook*, 1953 edn, ARRL, p542.
- [3] *VHF/UHF Manual*, 4th edn, ed G R Jessop, G6JP, RSGB, 1983, p3.10.
- [4] *Microwave Handbook*, Vol 1, ed M W Dixon, G3PFR, RSGB, 1989, p5.14ff.
- [5] *The Design of Operational Amplifier Circuits, with Experiments*, Howard M Berlin, W3HB, E & L Instruments Inc, Derby, Conn, USA, 1977.

