

# 16 Practical VHF/UHF Antennas



Peter Swallow, G8EZE

VHF and UHF antennas differ from their HF counterparts in that the diameter of their elements are relatively thick in relationship to their length and the operating wavelength, and transmission line feeding and matching arrangements are used in place of lumped elements and ATUs.

## THE (VHF) DIPOLE ANTENNA

At VHF and UHF, most antenna systems are derived from the dipole or its complement, the slot antenna. Many antennas are based on half-wave dipoles fabricated from wire or tubing. The feed point is usually placed at the centre of the dipole, for although this is not absolutely necessary, it can help prevent asymmetry in the presence of other conducting structures.

The input impedance is a function of both the dipole length and diameter. A radiator measuring exactly one half wavelength from end to end will be resonant (ie will present a purely resistive impedance) at a frequency somewhat lower than would be expected from its dimensions. Curves of 'end correction' such as Fig 16.1 show by how much a dipole should be shortened from the expected half wavelength to be resonant at the desired frequency.

The change of reactance close to half-wavelength resonance as a function of the dipole diameter is shown in Fig 16.2.

In their simplest form, dipole antennas for 2m and 70cm can be constructed from 2mm diameter enamelled copper wire and fed directly by a coaxial cable as shown in Fig 16.3. The total element length (tip to tip) should be 992mm for 145MHz operation and 326mm to cover the band 432 to 438MHz. The impedance will be around 70 ohms for most installations, so that a 50-ohm coaxial cable would present a VSWR of around 1.4:1 at the transceiver end.

A more robust construction can be achieved using tubing for the elements and moulded dipole centre boxes, available from a number of amateur radio antenna manufacturers and at radio rallies. The dipole length should be shortened in accordance with Fig 16.1 to compensate for the larger element diameters. Construction ideas and UK sources of materials can be found at [1].

Note that this simple feed may result in currents on the outside of the cable, and consequently a potential to cause interference to other electronic equipment when the antenna is used for transmitting. This can be reduced or eliminated by using a balun at the feed point.

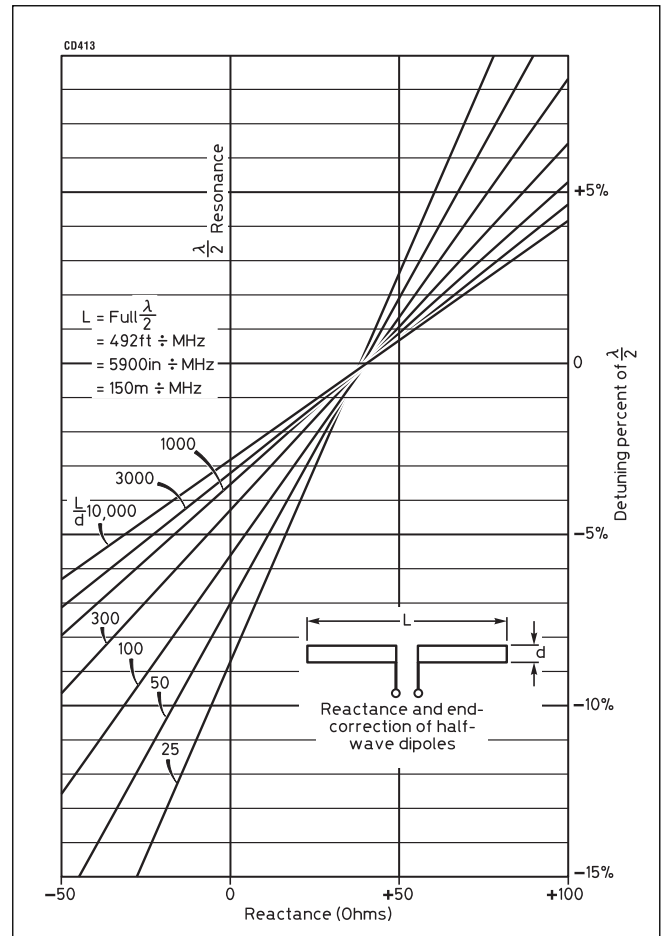

Fig 16.2: Tuning and reactance chart for half-wave dipoles as a function of diameter

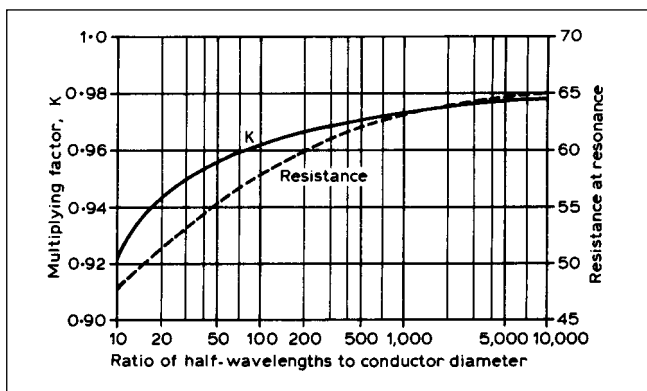

Fig 16.1: Length correction factor for half-wave dipole as a function of diameter

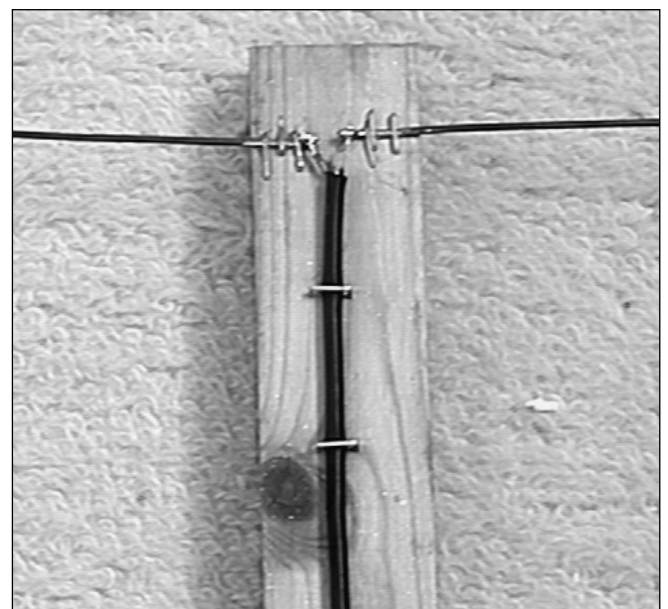
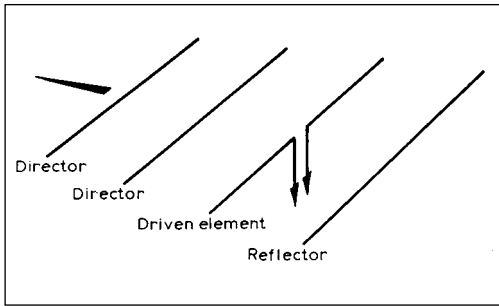

Fig 16.3: Simple dipole construction for 2m and 70cm

**Fig 16.4:** Simple Yagi antenna structure, using two directors and one reflector in conjunction with a driven element



## THE YAGI AND ITS DERIVATIVES

### The Yagi Antenna

The Yagi antenna was originally investigated by Uda and subsequently brought to Western attention by Yagi in 1928 in a form similar to that shown in **Fig 16.4**. It consists of a driven element combined with an in-line parasitic array. There have since been many variations of the basic concept, including its combination with log-periodic and backward-wave techniques.

To cover all variations of the Yagi antenna is beyond the scope of this handbook. A great number of books and many articles have been published on the subject, and a wide range of theoretical and practical pages can be found on the Internet with a simple search.

Many independent investigations of multi-element Yagi antennas have shown that the gain of a Yagi is directly proportional to the array length. There is a certain amount of latitude in the position of the elements along the array. However, the optimum resonance of each element will vary with the spacing chosen. With Greenblum's dimensions [2], in **Table 16.1**, the gain will not vary more than 1dB from the nominal value. The most critical elements are the reflector and first director as they decide the spacing for all other directors and most noticeably affect the matching. Solutions may be refined for the materials and construction methods available using one of the many software tools now freely available from the Internet, and discussed elsewhere in this handbook. These tools can be used to assess the sensitivity of a given design to alternative diameter elements and dimensions.

The optimum director lengths are normally greater the closer the particular director is to the driven element. (The increase of capacitance between elements is balanced by an increase of inductance, ie length through mutual coupling.) However, the length does not decrease uniformly with increasing distance from the driven element. **Fig 16.5** shows experimentally derived element lengths for various material diameters. Elements are

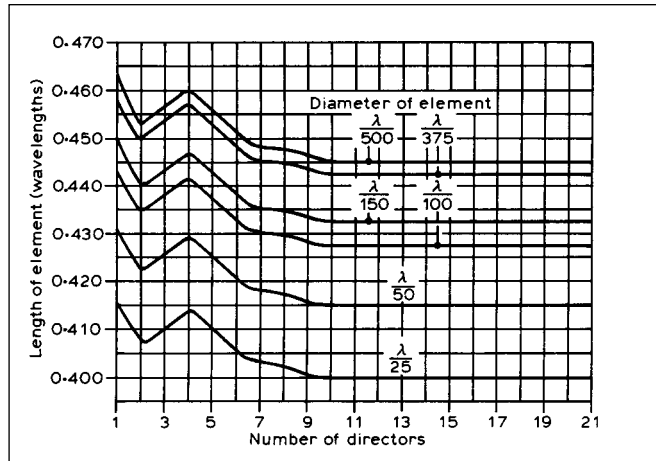
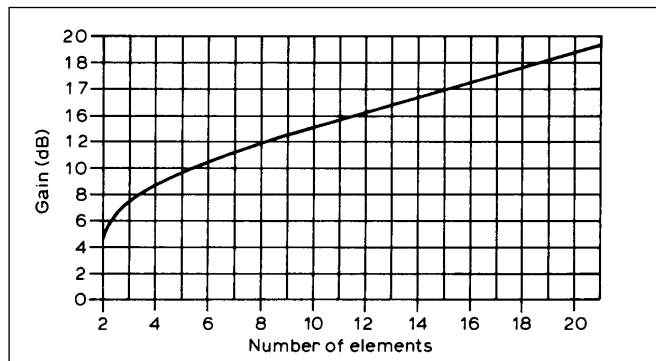

**Fig 16.5:** Length of director versus position in the array for various element diameters (*ARRL Antenna Book*)

mounted through a cylindrical metal boom that is two or three diameters larger than the elements.

Some variation in element lengths will occur using different materials or sizes for the support booms. This will be increasingly critical as frequency increases. The water absorbency of insulating materials will also affect the element lengths, particularly when in use, although plastics other than nylon are usually satisfactory. **Fig 16.6** shows the expected gain for various numbers of elements if the array length complies with **Fig 16.7**.

The results obtained by G8CKN using the 'centre spacing' of Greenblum's optimum dimensions shown in **Table 16.1** produced identical gains to those shown in **Fig 16.6**. Almost identical radiation patterns (**Fig 16.8**) were obtained for both the E



**Fig 16.6:** Gain in dBi versus the number of elements of the Yagi array (*ARRL Antenna Book*)

Number of elements	R-DE	DE-D1	D1-D2	D2-D3	D3-D4	D4-D5	D5-D6
2	0.15 -0.20						
2		0.07 -0.11					
3	0.16 -0.23	0.16 -0.19					
4	0.18 -0.22	0.13 -0.17	0.14 -0.18				
5	0.18 -0.22	0.14 -0.17	0.14 -0.20	0.17 -0.23			
6	0.16 -0.20	0.14 -0.17	0.16 -0.25	0.22 -0.30	0.25 -0.32		
8	0.16 -0.20	0.14 -0.16	0.18 -0.25	0.25 -0.35	0.27 -0.32	0.27 -0.33	0.30 -0.40
8 to N	0.16 -0.20	0.14 -0.16	0.18 -0.25	0.25 -0.35	0.27 -0.32	0.27 -0.32	0.35 -0.42

DE = driven element, R = reflector and D = director. N = any number. Director spacing beyond D6 should be 0.35-0.42

**Table 16.1:** Greenblum's optimisation for multielement Yagis

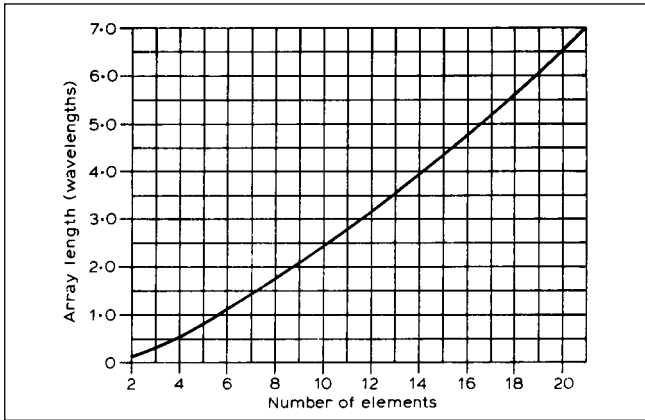

Fig 16.7: Optimum length of a Yagi antenna as a function of the number of elements (ARRL Antenna Book)

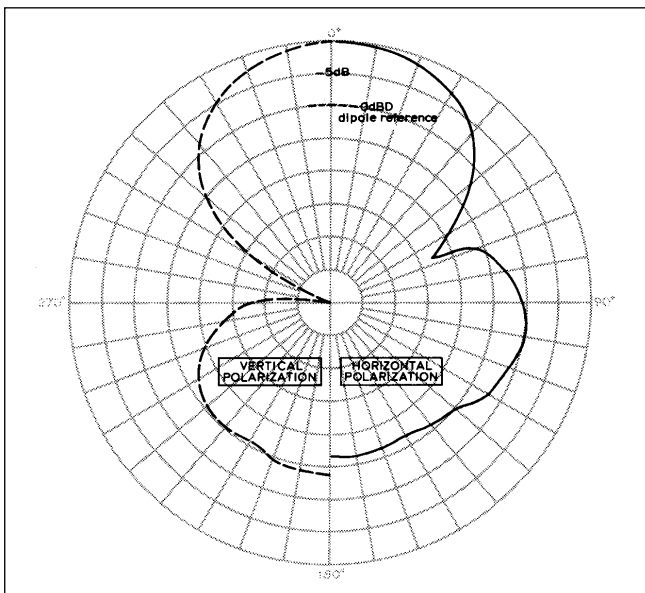

Fig 16.8: Radiation pattern for a four-element Yagi using Greenblum's dimensions

and H planes (V or H polarisation). Sidelobes were at a minimum and a fair front-to-back ratio was obtained.

Considerable work has been carried out by Chen and Cheng on the optimising of Yagis by varying both the spacing and resonant lengths of the elements [3].

Table 16.2 and Table 16.3 show some of their results obtained in 1974, by optimising both spacing and resonant lengths of elements in a six element array.

Table 16.3 shows comparative gain of a six element array with conventional shortening of the elements or varying the element lengths alone. The gain figure produced using conventional shortening formulas was 8.77dB relative to a  $\lambda/2$  dipole (dBd). Optimising the element lengths produced a forward gain of 10dBd. Returning to the original element lengths and optimising the element spacing produced a forward gain of 10.68dBd. This is identical to the gain shown for a six-element Yagi in Fig 16.6. Using a combination of spacing and element length adjustment obtained a further 0.57dBd, giving 11.25dBd as the final forward gain as shown in Table 16.3.

A publication of the US Department of Commerce and National Bureau of Standards [4], provides very detailed experimental information on Yagi dimensions. Results were obtained from measurements to optimise designs at 400MHz using a model antenna range.

The information, presented largely in graphical form, shows very clearly the effect of different antenna parameters on realisable gain. For example, it shows the extra gain that can be achieved by optimising the lengths of the different directors, rather than making them all of uniform length. It also shows just what extra gain can be achieved by stacking two elements, or from a 'two-over-two' array.

The paper presents:

- (a) The effect of reflector spacing on the gain of a dipole.
- (b) Effect of different equal-length directors, their spacing and number on realisable gain.
- (c) Effect of different diameters and lengths of directors on realisable gain.
- (d) Effect of the size of a supporting boom on the optimum length of parasitic elements.
- (e) Effect of spacing and stacking of antennas on gain.
- (f) The difference in measured radiation patterns for various Yagi configurations.

	$h_1/\lambda$	$h_2/\lambda$	$h_3/\lambda$	$h_4/\lambda$	$h_5/\lambda$	$h_6/\lambda$	Gain (dBd)
Initial array	0.255	0.245	0.215	0.215	0.215	0.215	8.78
Length-perturbed array	0.236	0.228	0.219	0.222	0.216	0.202	10.00

$b_{i,1} = 0.250\lambda, b_{i,2} = 0.310\lambda (i = 3, 4, 5, 6), a = 0.003369\lambda$

Table 16.2: Optimisation of six-element Yagi-Uda array (perturbation of element lengths)

	$h_1/\lambda$	$h_2/\lambda$	$h_3/\lambda$	$h_4/\lambda$	$h_5/\lambda$	$h_6/\lambda$	$b_{21}/\lambda$	$b_{22}/\lambda$	$b_{43}/\lambda$	$b_{34}/\lambda$	$b_{35}/\lambda$	Gain (dBd)
Initial array	0.255	0.245	0.215	0.215	0.215	0.215	0.250	0.310	0.310	0.310	0.310	8.78
Array after spacing perturbation	0.255	0.245	0.215	0.215	0.215	0.215	0.250	0.289	0.406	0.323	0.422	10.68
Optimum array after spacing and length perturbations	0.238	0.226	0.218	0.215	0.217	0.215	0.250	0.289	0.406	0.323	0.422	11.26

Table 16.3: Optimisation for six-element Yagi-Uda array (perturbation of element spacings and element lengths)

Length of Yagi ( $\lambda$ )	0.4	0.8	1.20	2.2	3.2	4.2
Length of reflector ( $\lambda$ )	0.482	0.482	0.482	0.482	0.482	0.475
Length of directors ( $\lambda$ ):						
1st	0.424	0.428	0.428	0.432	0.428	0.424
2nd	-	0.424	0.420	0.415	0.420	0.424
3rd	-	0.428	0.420	0.407	0.407	0.420
4th	-	-	0.428	0.398	0.398	0.407
5th	-	-	-	0.390	0.394	0.403
6th	-	-	-	0.390	0.390	0.398
7th	-	-	-	0.390	0.386	0.394
8th	-	-	-	0.390	0.386	0.390
9th	-	-	-	0.398	0.386	0.390
10th	-	-	-	0.407	0.386	0.390
11th	-	-	-	-	0.386	0.390
12th	-	-	-	-	0.386	0.390
13th	-	-	-	-	0.386	0.390
14th	-	-	-	-	0.386	-
15th	-	-	-	-	0.386	-
Director spacing ( $\lambda$ )	0.20	0.20	0.25	0.20	0.20	0.308
Gain (dBd)	7.1	9.2	10.2	12.25	13.4	14.2

Element diameter  $0.0085\lambda$ . Reflector spaced  $0.2\lambda$  behind driven element. Measurements are for 400MHz by P P Viezicke.

**Table 16.4: Optimised lengths of parasitic elements for Yagi antennas of six different boom lengths**

The highest gain reported for a single boom structure is 14.2dBd for a 15-element array ( $4.2\lambda$  long and reflector spaced at  $0.2\lambda$ , with 13 graduated directors). See **Table 16.4**.

It has been found that array length is of greater importance than the number of elements, within the limit of a maximum element spacing of just over  $0.4\lambda$ .

Reflector spacing and, to a lesser degree, the first director position affects the matching of the Yagi. Optimum tuning of the elements, and therefore gain and pattern shape, varies with different element spacing.

Near-optimum patterns and gain can be obtained using Greenblum's dimensions for up to six elements. Good results for a Yagi in excess of six elements can still be obtained where ground reflections need to be minimised.

Chen and Cheng employed what is commonly called the long Yagi technique. Yagis with more than six elements start to show an improvement in gain with fewer elements for a given boom length when this technique is used.

As greater computing power has become available, it has been possible to investigate the optimisation of Yagi antenna gain more extensively, taking into account the effects of mounting the elements on both dielectric and metallic booms, and the effects of tapering the elements at lower frequencies.

Dr J Lawson, W2PV, carried out an extensive series of calculations and parametric analyses, collated in reference [5], which although specifically addressing HF Yagi design, explain many of the disappointing results achieved by constructors at VHF and above. In particular, the extreme sensitivity of some designs to minor variations of element length or position are revealed in a series of graphs which enable the interested constructor to select designs that will be readily realisable.

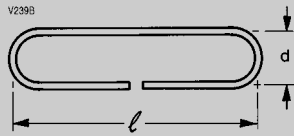
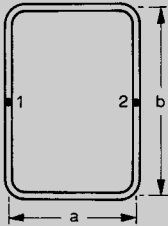
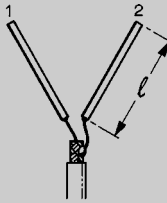
	70.3MHz	145MHz	433MHz
<b>Driven elements</b>			
Dipole (for use with gamma match)	79 (2000)	38 (960)	12 3/4 (320)
Diameter range for length given	1/2 - 3/4 1/8 - 1/4 (12.7 - 19.0)	(6.35 - 9.5)	1/4 - 3/8 (3.17 - 6.35)
			
<i>Folded dipole 70-ohm feed</i>			
l length centre-centre	77 1/2 (1970)	38 1/2 (980)	12 1/2 (318)
d spacing centre-centre	2 1/2 (64)	7/8 (22)	1/2 (13)
Diameter of element	1/2 (12.7)	1/4 (6.35)	1/8 (3.17)
			
			
centre/centre	32 (810)	15 (390)	5 1/8 (132)
b centre/centre	96 (2440)	46 (1180)	152 (395)
<b>Parasitic elements</b>			
Element			
Reflector	85 1/2 (2170)	40 (1010)	13 1/4 (337)
Director D1	74 (1880)	35 1/2 (902)	11 1/4 (286)
Director D2	73 (1854)	35 1/4 (895)	11 1/8 (282)
Director D3	72 (1830)	35 (890)	11 (279)
Succeeding directors	1in less (25)	1/2in less (13)	1/8in less
Final director	2in less (50)	1in less (25)	3/4in less
One wavelength (for reference)	168 3/4 (4286)	81 1/2 (2069)	27 1/4 (693)
Diameter range for length given	1/2 - 3/4 (12.7 - 19.0)	1/4 - 3/8 (6.35 - 9.5)	1/8-3/4 (3.17 - 6.35)
<b>Spacing between elements</b>			
Reflector to radiator	22 1/2 (572)	17 1/2 (445)	5 1/2 (140)
Radiator to D1	29 (737)	17 1/2 (445)	5 1/2 (140)
D1 to D2	29 (737)	17 1/2 (445)	7 (178)
D2 to D3, etc	29 (737)	17 1/2 (445)	7 (178)

*Dimensions are in inches with millimetre equivalents in brackets.*

**Table 16.5: Typical dimensions of Yagi antenna components. Dimensions are in inches with metric equivalents in brackets**

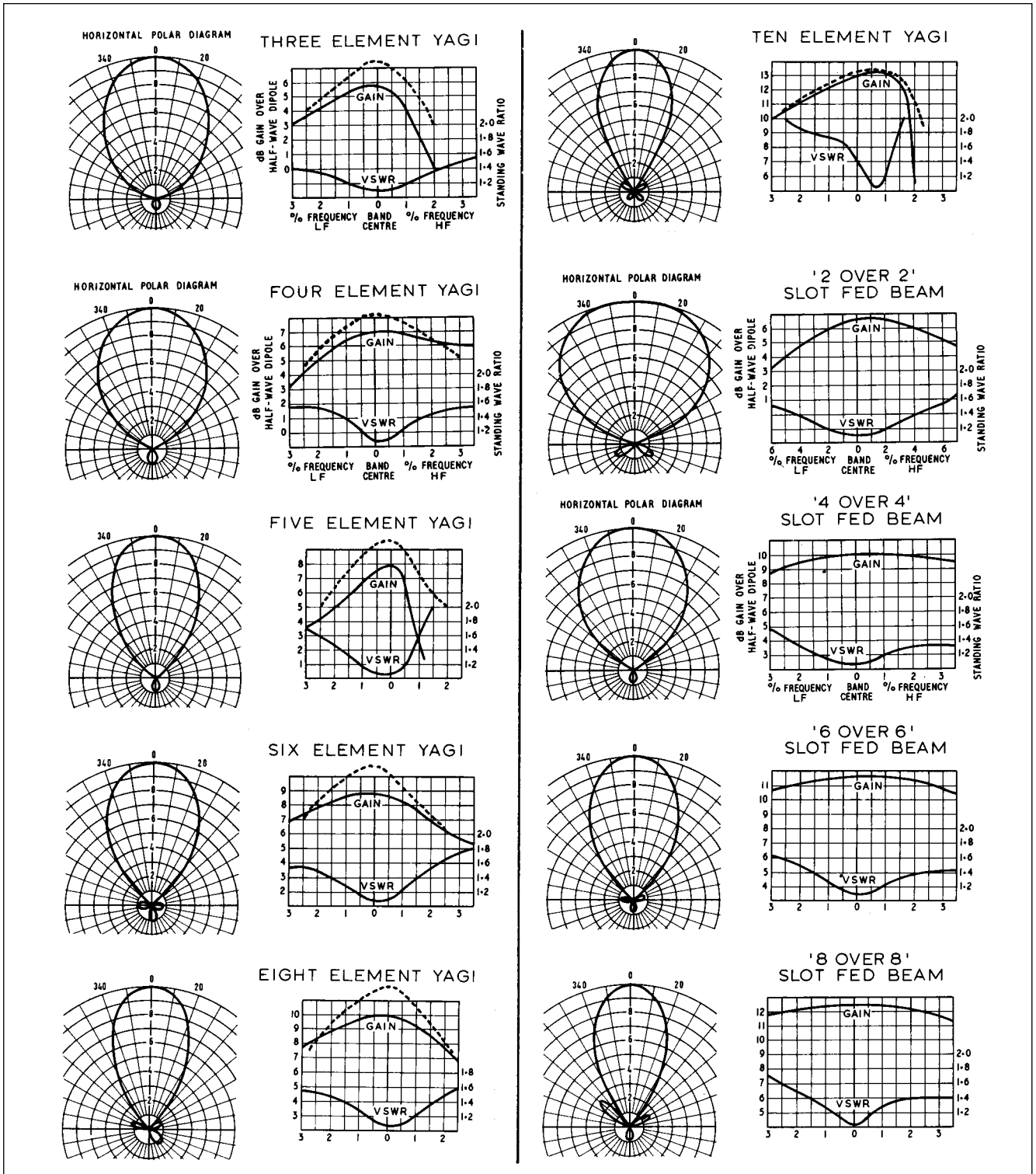

**Fig 16.9: Charts showing voltage polar diagram and gain against VSWR of Yagi and skeleton-slot antennas. In the case of the six Yagi antennas the solid line is for conventional dimensions and the dotted lines for optimised results discussed in the text**

The keen constructor with a personal computer may now also take advantage of modelling tools specifically designed for optimisation of Yagi antennas and arrays, eg [6], although some care is needed in their use if meaningful results are to be assured. The Internet is a good source for Yagi antenna design and optimisation programmes, many of which can be obtained free of charge, or for a nominal sum.

From the foregoing, it can be seen that several techniques can be used to optimise the gain of Yagi antennas. In some circum-

stances, minimisation of sidelobes is more important than maximum gain, and a different set of element spacings and lengths would be required to achieve this. Optimisation with so many independent variables is difficult, even with powerful computing methods, as there may be many solutions that yield comparable results.

Techniques of 'genetic optimisation' have been developed and widely adopted, which can result in surprising, but viable designs [7], [8]. The technique requires the use of proven computer-based analysis tools such as NEC, MININEC or their derivatives.

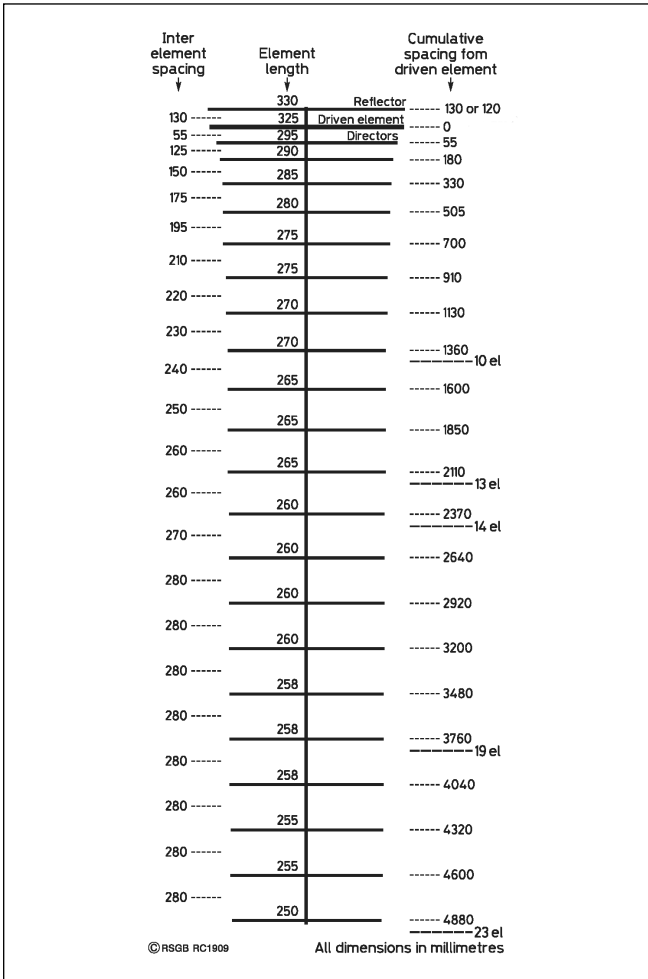

Fig 16.10: Element lengths and spacings for 10 / 13 / 14 / 19 / 23 element 435MHz Yagi

Number of elements	10	13	14	19	23
Gain (dBd)	11.7	13	13.3	15	16
Horizontal beamwidth	37°	30.5°	30°	26.5°	24°
Vertical beamwidth	41°	33°	32°	28°	24.5°

Table 16.6: Performance of 10 / 13 / 14 / 19 / 23 element 435MHz Yagis

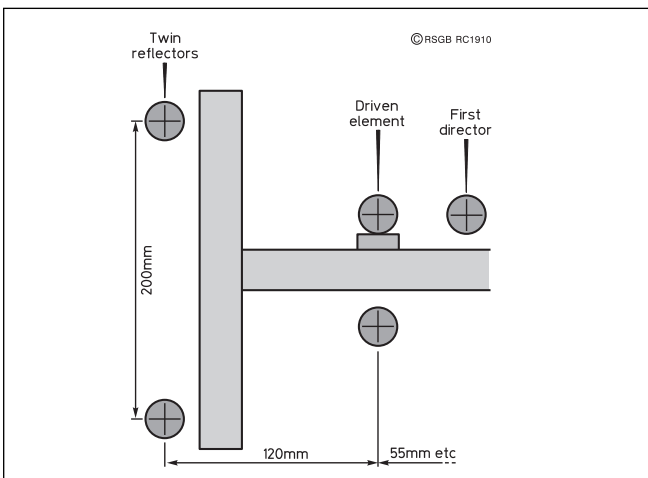

Fig 16.11: Twin reflector details

The required parameters (gain, sidelobe levels, input impedance) are described and weighted according to their importance to the designer, together with the permitted variables.

A figure of merit is defined, which incorporates the weighting of the desired parameters. An initial structure is input, which is then analysed, its performance recorded, and an incremental change made to one of the variables. The process is repeated whilst the figure of merit continues to improve. However, unlike conventional optimisation methods, where local optimisation may obscure a better result that may also be available, a random process selects the variable(s) to be changed until a reasonably large seed population has been generated. Selection, crossover and mutation processes are then used to filter out poor designs and retain better ones, with each successive generation possibly containing better designs than the preceding one, if the selection algorithms have been well constructed. This technique is readily available to amateurs with home computers [9], [10].

Dimensions for Yagi antennas for 70, 145 and 433MHz are shown in Table 16.5. The table also includes dimensions for feeding two stacked Yagi antennas with a skeleton slot feed, described later in this chapter.

Typical radiation patterns, gains and VSWR characteristics for a range of different Yagi antennas are shown in Fig 16.9. The figure also contains information on skeleton slot Yagis, discussed later in this chapter.

### Long Yagi Antennas

The NBS optimisation described above has been extended by American amateurs [11]. Tapering of the spacing was studied by W2NLY and W6QKI who found [12] that, if the spacing was increased up to a point and thereafter remained constant at  $0.3-0.4\lambda$ , another optimisation occurred. Both these are single optimisation designs.

Günter Hoch, DL6WU, looked at both techniques and decided that they could be applied together. The director spacing was increased gradually until it reached  $0.4\lambda$  and the length was tapered by a constant fraction from one element to the next. The result is a highly successful doubly optimised antenna [13], [14].

Great care is required in constructing these antennas if the predicted gain is to be realised. This means following the dimensions and fixing methods exactly as laid out in the designer's instructions. Details for building a number of long Yagi antennas for VHF and UHF can be found through links at G3SEK's website [15].

### F5JIO long Yagi for 435MHz

This antenna can be built with 10, 13, 14, 19 or 23 elements according to the space available (Fig 16.10). Its performance is shown in Table 16.6.

An extra 0.2dB gain and some reduction of backlobes can be obtained by fitting twin reflectors (Fig 16.11), but note that the spacing between the driven element and the reflector is reduced from 130mm to 120mm.

The 23 element version requires a boom length in excess of 5010mm, and must be solidly constructed and supported. The boom is made from 20 x 20mm square aluminium tubing, and all elements from 8mm diameter (round) tubing. All elements except the driven element must be insulated from the boom and mounted so that their centres are 8mm above its upper surface. Dimensions for the driven element and cable balun construction to provide a feed impedance of 50 ohms are shown in Fig 16.12.

Balun cable lengths and calculations are shown in Table 16.7. The cable should be a 75-ohm miniature PTFE insulated type, such as URM111 or equivalent. A small weatherproof box should be fitted over the ends of the element, inside

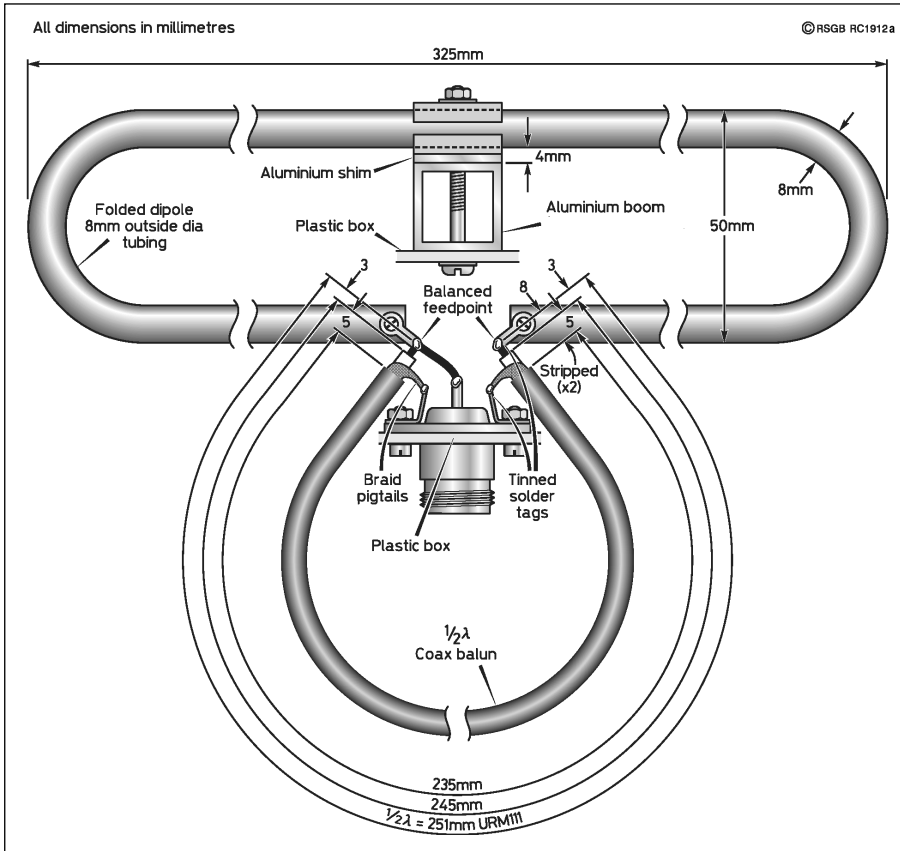

Fig 16.12: 435MHz long Yagi driven element and balun

$\lambda/2@435\text{MHz} = 300,000/435 \times 2 = 345\text{mm}$  (in air)  
 In URM111: 16mm of stripped end (@ $v=0.9$ ) = 18mm (electrical)  
 Cutting length =  $345\text{mm} - 18\text{mm}$  (@ $v=0.72$  PTFE insulation) = 235mm (unstripped)  
 Note: Use  $v=0.66$  for Polyethylene insulation

Table 16.7: Balun cable length calculation

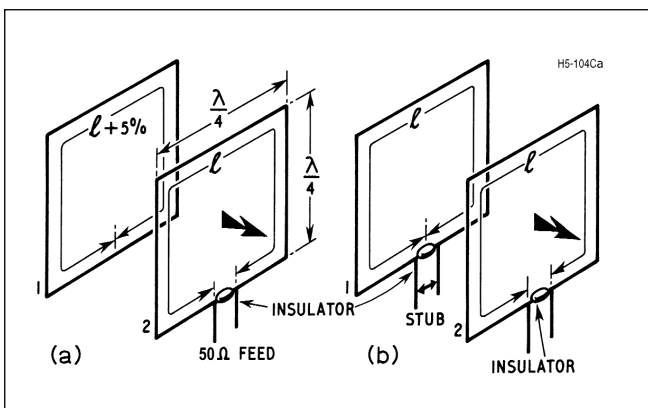

Fig 16.13: Quad antenna structure and electrical dimensions

which the balun cable may also be coiled. The driven element may be made from 9.5 x 1.6mm flat aluminium bar which is easier to bend and drill.

**Quad Antenna**

The Quad antenna can be thought of as a Yagi antenna comprising pairs of vertically stacked, horizontal dipoles with their ends bent towards each other and joined, Fig 16.13. The antenna produces horizontally polarised signals, and in spite of its relatively small physical size a forward gain of 5.5 to 6dB can be obtained with good front-to-back ratio. Additional quad or single element directors can be added to the basic two element array in the same manner as the Yagi.

Typical dimensions for lightweight wire 51, 71 and 145MHz Quad antennas are given in Table 16.8, and a photograph of the 145MHz version is shown in Fig 16.14. This variant has equal size loops and uses a stub to tune the reflector. The boom is made from 15mm copper tubing with a T-piece in the centre for fixing to the mast or rotator. The element supports are made from 10 or 12mm square wooden dowelling fixed to square pieces of plywood using nuts and bolts. The plywood centres are fixed to the boom using L-brackets and hose clamps. A 50-ohm coaxial cable can be connected directly to the driven element. A 1:1 balun will minimise currents

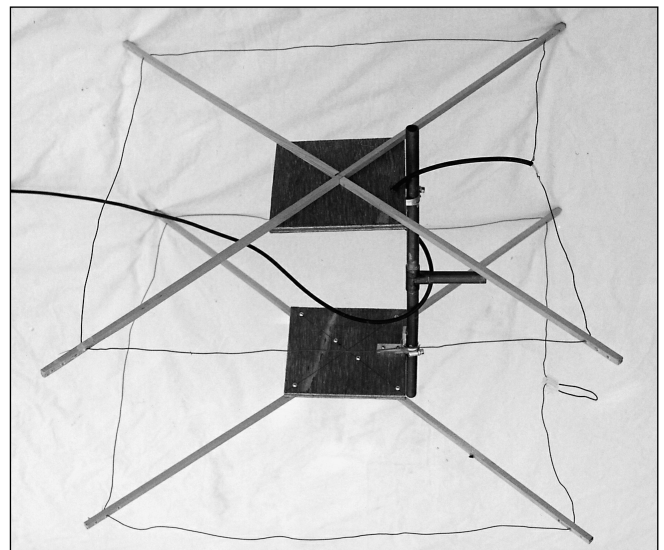

Fig 16.14: Wire quad antenna for 145MHz

Table 16.8: Design dimensions for 51, 70 and 144MHz quad antennas

Band	Element spacing, mm	Reflector sides, mm	Driven element sides, mm
51MHz	840	1560	1500
71.5MHz	600	1210	1080
145MHz	294	548	524

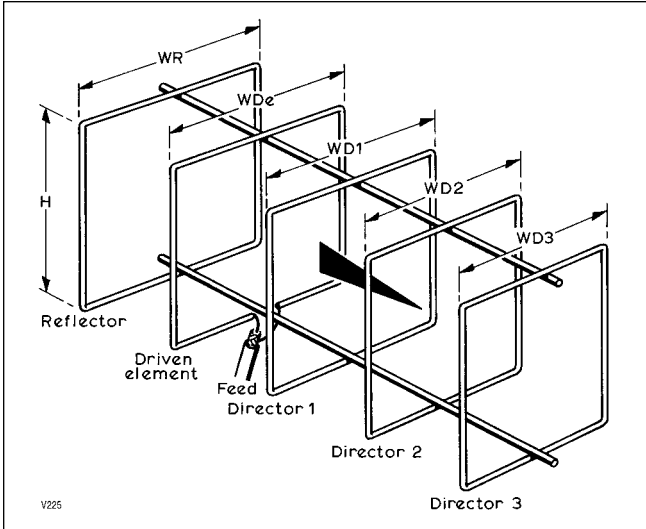

Fig 16.15: General arrangement for a multi-element quad antenna

on the outer of the cable, preventing distortion of the radiation pattern and potential EMC problems.

Quads may be stacked or built into a four square assembly in the same way as the basic Yagi (see below).

**Multi-element quad (Quagi)**

The multiple element quad antenna or "Quagi" can offer a better performance with reduced sidelobes compared with the average simple Yagi, whilst retaining a simple robust form of construction (Fig 16.15). Dimensions for a four element, 145MHz antenna are given in Table 16.9. Generally the maximum number of elements used is five. Where more gain is needed, a pair may be stacked vertically or horizontally, although for maximum mechanical strength the vertical arrangement is to be preferred.

The whole structure may be made up of aluminium tube (or solid rod for the elements). The only insulator necessary is at the feed point of the driven element. In construction, it is best to make each element from one piece of material. A 3/8in aluminium rod will bend to form corners much more readily than tube that would also need a 'filler'. The corner radius should be kept small, and allowance must be made for the resultant 'shortening'

Height H	21 (533)	21	21	21
Width reflector WR	24½ (622)	24½	24½	24½
Driven WDe	20½ (520)	20½	20½	20½
Director 1 WD1	-	18 (457)	18	18
Director 2 WD2	-	-	16 (406)	16
Director 3 WD3	-	-	-	14 (356)
Spacing				
Reflector to Driven	7 (178)	19 (483)	20 (508)	20
Driven to Director 1	-	12 (305)	14½ (368)	14½
Director 1 to				
Director 2	-	-	14½	14½
Director 2 to				
Director 3	-	-	-	14½
Approx gain (dBd)	5	7	10.5	12.5

Element diameters all 3/8in (9.35mm). Feed impedance in all cases is 75. Dimensions are in inches with millimetre equivalents in brackets.

Table 16.9: Dimensions for a multi-element quad antenna for 144MHz

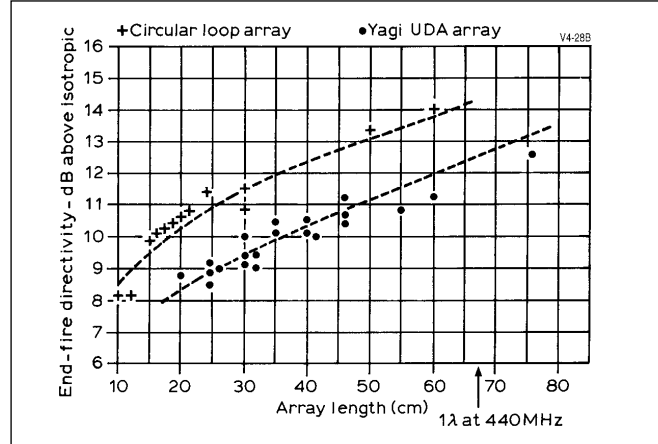

Fig 16.16: Comparative directivity of the Yagi and Quad as a function of overall array length. Although measured with circular loops, performance with square loops is comparable (ARRL Antenna Book). Note the gains are in dBi, not dBd

of element length, ie side of the quad element. For mechanical simplicity (and appearance) it is a good idea to arrange for all the element heights to be the same, and vary the width.

Fixing the elements to the boom and the boom to the mast is conveniently done with standard TV antenna fittings. Although suitable blocks or clamping arrangements can be made by the constructor, they often tend to be unnecessarily heavy. Purchased TV fittings can be more cost-effective than obtaining raw materials and there is also much less effort involved in construction. There are also several antenna manufacturing companies catering for the radio amateur who sell tubing, mast clamps and small components for securing elements to booms. They can often be found at rallies and amateur radio events, or advertise in the pages of RadCom.

If preferred, the reflector may be made the same size as the driven element, and tuned with a suitable stub. If vertical polarisation is required, instead of horizontal, then the feeder can be attached to the centre of one of the vertical sides of the driven element. (The same 'side' must always be used for correct phase relationship within stacked arrays.)

The relative performance of multi-element quad and Yagi antennas is shown in Fig 16.16, demonstrating that the shorter quad structures can provide gains comparable with longer Yagi antennas. This may be of benefit if turning space is limited (eg inside a loft). However, there is no such thing as a free lunch, and in general, the weight and wind loading of the multi-element quad antenna will be slightly greater than its Yagi counterpart.

**The loop Yagi**

At frequencies above 433MHz, the construction of multiple quad antennas can be considerably simplified by bending the elements into circular loops. High gains can be achieved by using large numbers of elements, and the relatively simple construction allows gains up to around 20dBi to be realised with manageable boom lengths [16].

A practical horizontally polarised four element loop Yagi antenna for 435MHz is shown in Fig 16.17. 2mm diameter enamelled copper wire elements are fixed to a tubular metal boom using hose clamps. A three terminal, plastic mains power connector block is used to connect the coaxial cable and provide the method for fastening the driven element to the boom. The enamel insulation is removed from the ends of the driven element to a distance of 20mm at one end and 50mm at the other. The 50mm end is folded into a loop and passed back into the connector



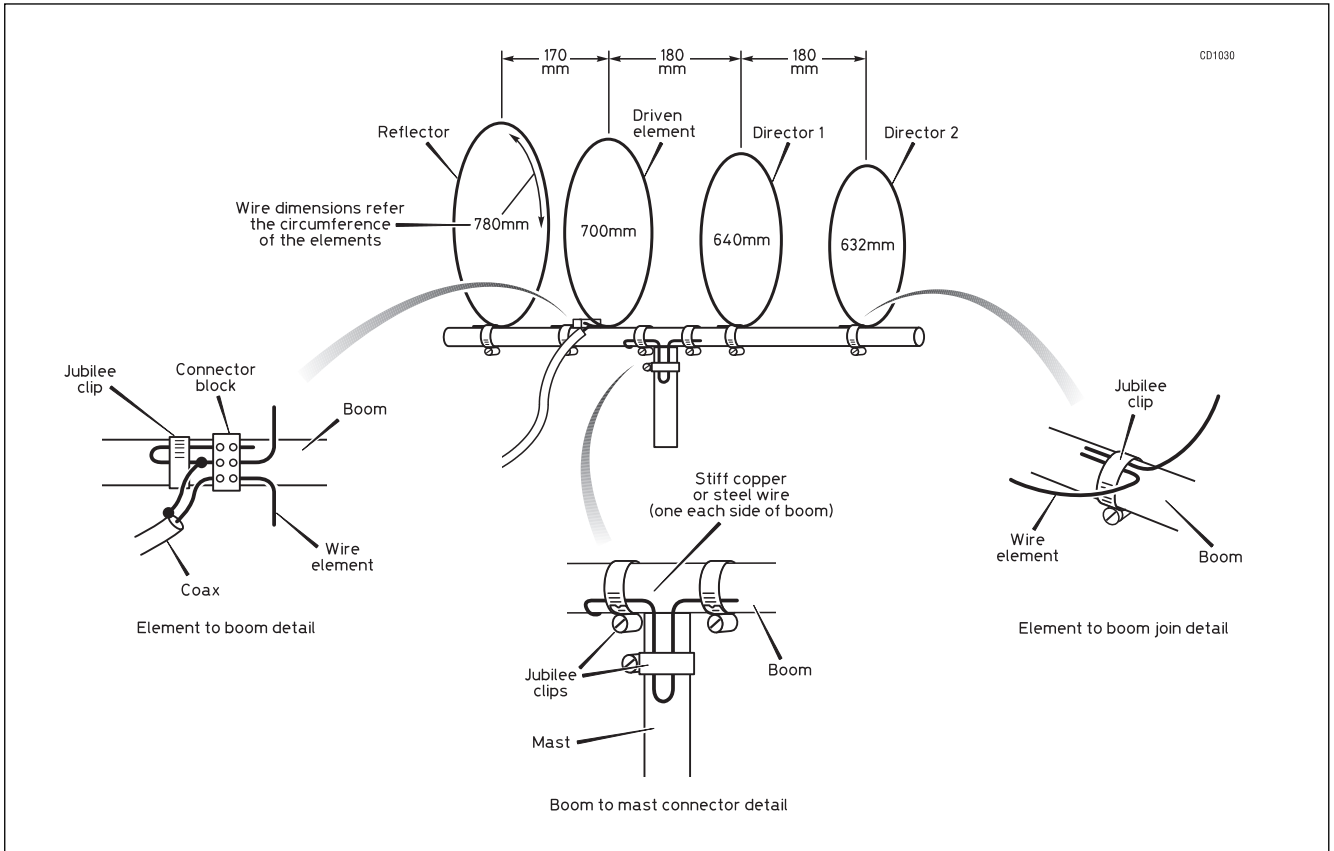

**Fig 16.17: A four element quad loop Yagi antenna for the 435MHz band**

block. The parasitic elements should be made 40mm longer than the dimensions shown, and the enamel removed from the last 20mm at each end. These ends should be bent at right angles and the remaining wire formed into a loop. The bent ends should be soldered together to simplify assembly. The boom and mast can be connected together using thick wire loops as shown, or the boom could be made from copper water pipe with a T-piece to connect to the support mast if preferred. A gain of around 9dBi should be achieved.

**GW3YDX Super Moxon Antenna**

This antenna is essentially a pair of Moxon Rectangle antennas, arranged in tandem, with the second antenna parasitically coupled to the first (see ‘Compact beams with bent elements’ in the Practical HF Antennas chapter). It may also be thought of as a four element Yagi antenna with the ends of each pair of elements bent towards each other so that they can be mechanically joined by insulators (Fig 16.18). The result is a very compact and structurally sound directional antenna with a gain of around 6dBi and a front to back ratio of 26.5dB (Fig 16.19). A VSWR of better than 1.5:1 in 50 ohms was achieved between 50.0 and 50.3MHz [17]. The horizontal dimensions of the 2m version are just 770 x 640mm (16.20).

Dimensions for 6, 4 and 2m variants are shown in Table 16.10, all dimensions are in mm measured from the tubing centres. Dimensions K, L and M are measured along the boom from the position of the longest element J=0 in Fig 16.18. The main elements are made from 1/2" aluminium alloy tubing with 3/8" tubing or rod used for the corners. A 1" square alloy boom is sufficient for the 6m version. Insulators for joining the element ends and the driven element centres can be made from 3/8" fibre-glass rod. The element end tubes can be slit and fitted with small stainless steel hose clamps to allow fine tuning. All four element

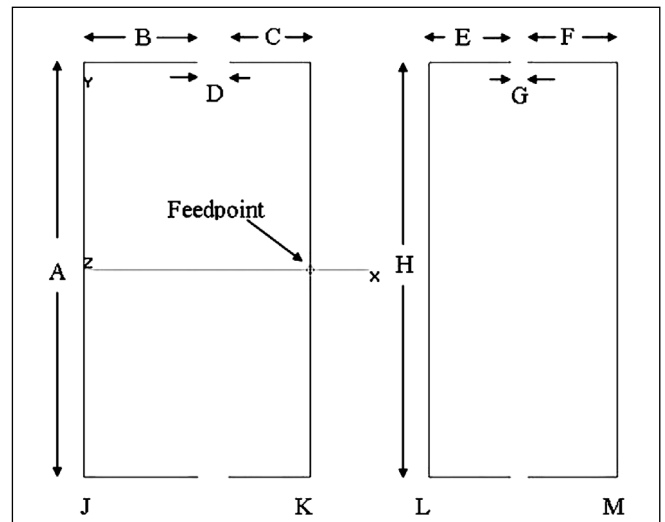

**Fig 16.18: Basic design of the Super Moxon. See Table 16.10 for 6m, 4m and 2m versions**

lengths should be altered by the same amount for each round of adjustments. A 1:1 50 ohm balun (see the Transmission Lines chapter) is required to feed the driven element.

The 4m version has been tested with input powers up to 1kW. The ends of the elements for the 2m version are separated by only 12mm, and has only been tested up to 50W input power. Appropriate precautions should be taken if high power operation is to be considered.

Note that the design is registered, and commercial manufacture requires the permission of the design owner [18]. However, radio amateurs may freely construct the antenna for their personal radio stations.

**Table 16.10: Tubing lengths for 6m, 4m and 2m versions of Fig 16.18. All dimensions are in mm, measured to tubing centres**

	A	B	C	D	E	F	G	H	J	K	L	M
6m	2160	395	280	105	290	310	60	2140	0	780	1201	1861
4m	1572	275	175	110	195	202	43	1572	0	560	860	1310
2m	730	135	86	55	82	90	12	730	0	276	434	615

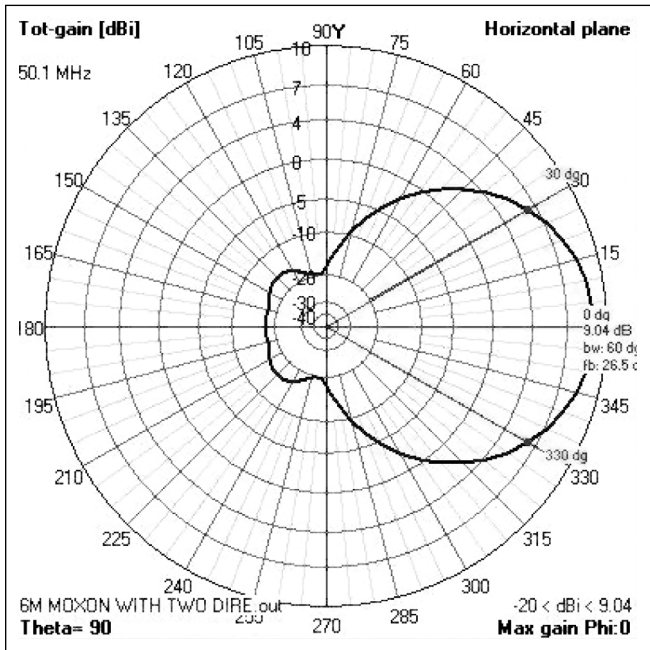

**Fig 16.19: Azimuth radiation pattern of 6m Super Moxon antenna calculated using 4NEC2**



**Fig 16.20: The 2m version of the Super Moxon is just 30" x 25"**

## ANTENNA ARRAYS

### Array Principles

The gain achievable with any antenna structure is ultimately limited by the fundamentals of its operation. However, higher gains can be achieved by using several antenna elements in an *array*. The array can comprise antennas *stacked* vertically above each other, or arranged side by side in *bays*, or a combination of both. These are *broadside* arrays, where most of the radiated power is projected at right angles to the plane in which the array elements lie.

An array can also be formed where the main beam is projected along the array of elements; these are *endfire* arrays, of which the HB9CV and Yagi antennas are examples.

An array of elements has a narrower beamwidth, and hence a higher gain than the individual antennas. The maximum achievable gain could be N times greater than one element fed with the same power ( $10\log_{10} N$  decibels) if there are N elements in the array. However, more complex feed arrangements can reduce the VSWR bandwidth and introduce losses, reducing the array gain. Arrays need care in construction and attention to detail, especially at UHF and above, but the results reward the effort expended.

Antenna array theory can be found in almost any book devoted to antennas. However, a good treatment with many radiation pattern examples can be found in Refs [19] and [20].

### Disadvantages of Multi-element Arrays

High gain cannot be achieved by simply stacking many elements close together. If we consider a dipole collecting power from an incident field for delivery to a load (receiver), it can be thought of as having a collecting area or effective aperture that is somewhat larger than the dipole itself. The higher the directivity of the antenna, the larger the effective aperture, as given by the relationship:

$$A_{eff} = \frac{\lambda^2}{4\pi} D$$

where D is the directivity of the antenna  
 $\lambda$  is the working wavelength

If the effective apertures of adjacent antennas overlap, the incoming RF energy is shared between them, and the maximum possible directivity (or gain) of the elements cannot be attained.

The generalised optimum stacking distance is a function of the half power beamwidth of the elements in the array, and is given by:

$$S_{opt} = \frac{\lambda}{\left[ 2 \sin \left( \frac{\phi}{2} \right) \right]}$$

where  $\phi$  is the half power beamwidth and  $S_{opt}$  is in wavelengths. Note that this is usually different for the E and H planes, so that the spacing of the elements is also usually different in each plane.

Also, when antennas are placed close together, *mutual coupling* between elements occurs. This leads to changes in the current distribution on the elements, changing both the radiation pattern and the feed point impedance of each element. The changes to the feed impedance often result in unequal powers being fed to the elements of the array, with consequential loss of gain.

Optimum stacking rules are based on the assumption of minimum mutual influence, which can be difficult to predict for complex antennas such as Yagis. However, antennas with low side-lobe levels are less susceptible than those with high sidelobes, as might be expected intuitively.

The coupling and effective aperture overlap problems cannot simply be solved by arbitrarily increasing the separation of the elements.

As the element spacing increases beyond one half wavelength, *grating sidelobes* appear, which can reduce the forward gain. The grating lobes are due solely to the array dimensions, and can be seen by plotting the array factor for the chosen configuration.

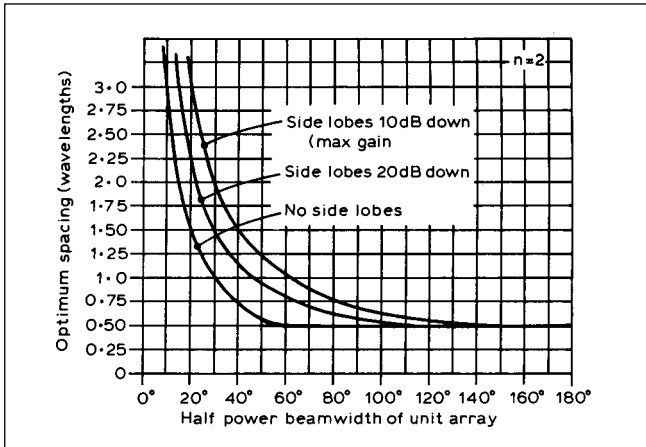

**Fig 16.21: Optimum stacking spacing for two-unit arrays. The spacing for no sidelobes, especially for small beamwidths, may result in no gain improvement over a single array element (ARRL Antenna Handbook)**

### Arrays of Identical Antennas

A parasitic array such as the Yagi can be stacked either vertically or horizontally to obtain additional directivity and gain. This is often called *collinear and broadside stacking*.

In stacking it is assumed that the antennas are identical in pattern and gain and will be matched to each other with the correct phase relationship, that is, 'fed in phase'. It is also assumed that for broadside stacking the corresponding elements are parallel and in planes perpendicular to the axis of the individual arrays.

With vertical stacking it is assumed the corresponding elements are collinear and all elements of the individual arrays are in the same plane.

The combination of the radiation patterns can add but can also cancel. The phase relationships, particularly from the side of the Yagi, are very complex.

Because of this complexity the spacing to obtain maximum forward gain does not coincide with the best sidelobe structure. Usually maximum gain is less important than reducing signals to the sides or behind the array.

If this is the case, 'optimum spacing' is one that gives as much forward gain as possible as long as the sidelobe structure does not exceed a specific amplitude compared with the main lobe. There will be different 'optimum' spacings according to the acceptable sidelobe levels.

**Fig 16.21** gives typical optimum spacing for two arrays under three conditions:

- (a) optimum forward gain with sidelobe down 10dB,
- (b) sidelobe 20dB down and
- (c) virtually no sidelobe.

The no-sidelobe case can correspond to no additional forward gain over a single antenna. **Fig 16.22** shows the optimum stacking spacing for four-unit arrays.

The maximum forward gain of two stacked arrays is theoretically +3dB, and +6dB for four stacked arrays. More complex arrays could produce higher gain but losses in the matching and phasing links between the individual arrays can outweigh this improvement. When stacking two arrays, the extra achievable gain is reduced at close spacing due to high mutual coupling effects. With two seven-element arrays a maximum gain of about 2.5dB can be achieved with  $1.6\lambda$  spacing; with two 15-element arrays it is also possible to achieve the extra 2.5dB but the spacing needs to be  $2\lambda$ .

The use of four arrays, in correctly phased two-over-two systems, can increase the realisable gain by about 5.2dB. Using seven-element Yagis produced a total gain of 14.2dB. With 15-element optimised Yagis a total gain of 19.6dB was obtained. (This was the highest gain measured during the experiments by Viezbicke [4].) The effects of stacking in combination with the physical and electrical phase relationship can be used to reduce directional interference.

Further information on antenna stacking can be found on G3SEK's web site [15].

An improvement in front-to-back ratio can be accomplished in vertical stacking by placing the top Yagi a quarter-wavelength in front of the lower Yagi as shown in **Fig 16.23**. The top antenna is fed  $90^\circ$  later than the bottom antenna by placing additional cable in the upper antenna feed run. The velocity factor of the cable must be taken into account.

### A Coaxial Cable Harness for Feeding Four Antennas

Four identical antennas such as Yagis can be mounted at the corners of a rectangle as a stacked and bayed array as shown in **Fig 16.24**, with separations determined by their beamwidths as described above. Whilst feed harnesses can be purchased with the antennas, they can also be constructed using standard coaxial cables and connectors, as shown in **Fig 16.25**. Each antenna and all cables must have an impedance of 50 ohms. The two feeders L1 and L3 connected in parallel result in  $25\Omega$  at Point A.

This is transformed to 100 ohms by the cable between A and B, which must be an odd number of quarter wavelengths long. The two 100-ohm impedances connected in parallel at point B result

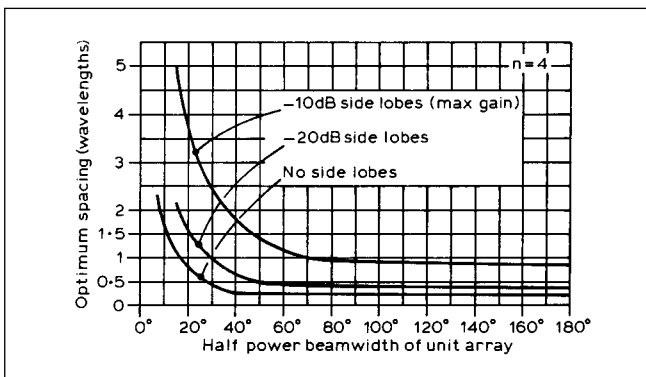

**Fig 16.22: Optimum stacking spacing for four-unit arrays (ARRL Antenna Handbook)**

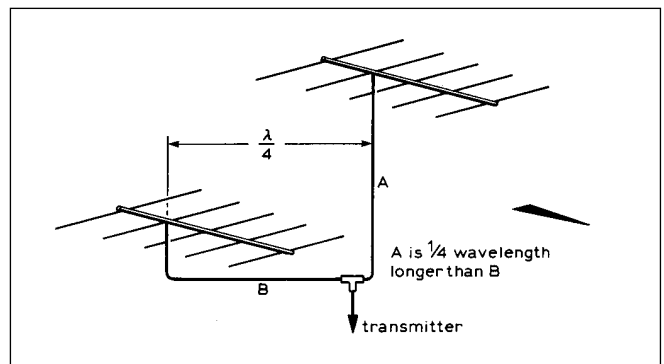

**Fig 16.23: Improving front to back ratio of stacked Yagi antennas with offset vertical mounting**

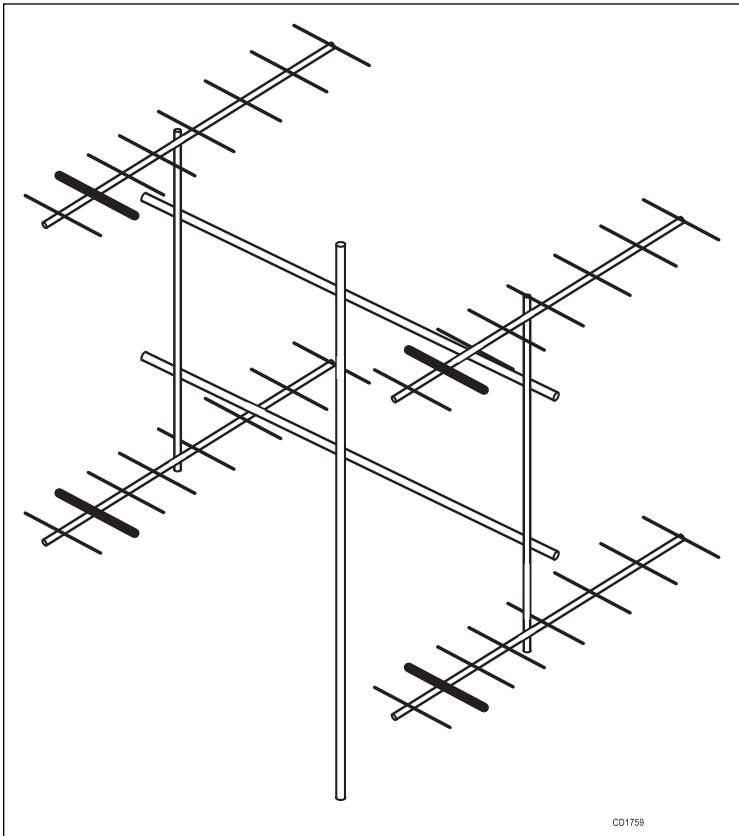

Fig 16.24: Four Yagi antennas stacked and bayed

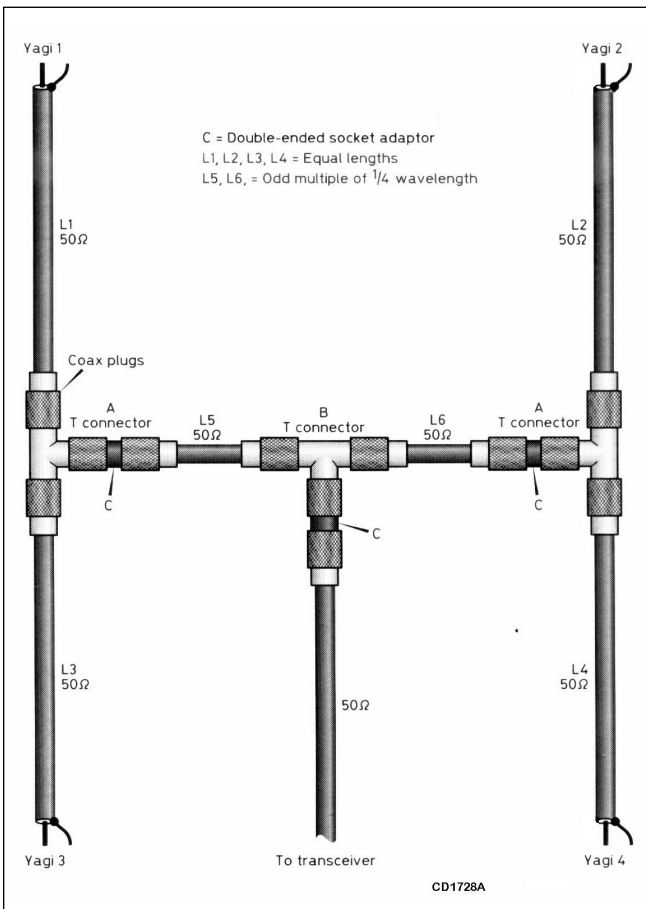

Fig 16.25: Coaxial feed harness for four antennas

in a 50-ohm impedance presented to the transceiver feeder. Feeders L1-L4 may be any convenient length, provided that they are all the same electrical length, preferably phase matched using measuring equipment..

### Skeleton Slot Feed for Two Stacked Yagis

A serious disadvantage of the Yagi array is that variation of the element lengths and spacing causes interrelated changes in the feed impedance. To obtain the maximum possible forward gain experimentally is extremely difficult. For each change of element length it is necessary to readjust the matching either by moving the reflector or by resetting a matching device.

However, a method has been devised for overcoming these practical disadvantages. It involves the use of a radiating element in the form of a skeleton slot. This is far less susceptible to the changes in impedance caused by changes in the length of the parasitic elements. A true slot would be a slot cut in an infinite sheet of metal. Such a slot, when approximately  $\lambda/2$  long, would behave in a similar way to a dipole radiator. In contrast with a dipole, however, the electric field produced by a vertical slot is horizontally polarised.

The skeleton slot was developed during experiments to find how much the 'infinite' sheet of metal could be reduced without the slot antenna losing its radiating property. The limit was found to occur when there remained approximately  $\lambda/2$  of metal beyond the slot edges. However, further experiments showed that a thin rod bent to form a 'skeleton slot' (approximately  $5\lambda/8$  by  $5\lambda/24$ ) exhibited similar properties to those of a true slot.

The way a skeleton slot works is shown in Fig 16.26. Consider two  $\lambda/2$  dipoles spaced vertically by  $5/8$ . Since the greater part of the radiation from each dipole takes place at the current maximum (ie the centre) the ends of the dipoles may be bent without serious effect.

These 'ends' are joined together with a high-impedance feeder, so that 'end feeding' can be applied to the bent dipoles. To radiate in phase, the power should be fed midway between the two dipoles.

The high impedance at this point may be transformed down to that of the feeder cable with a tapered matching

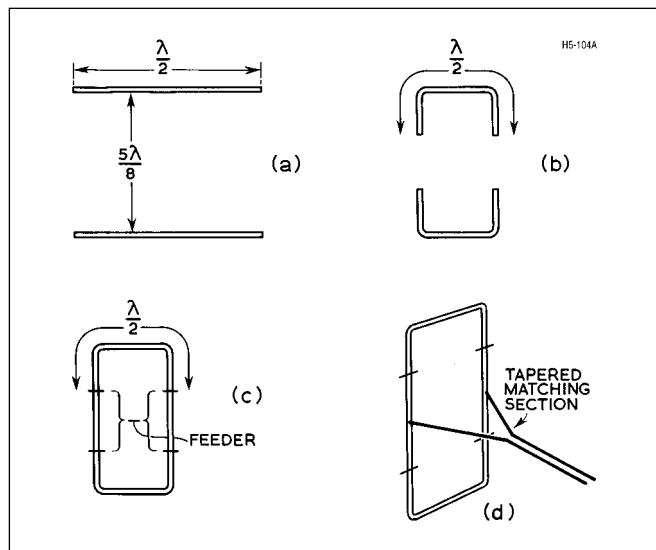
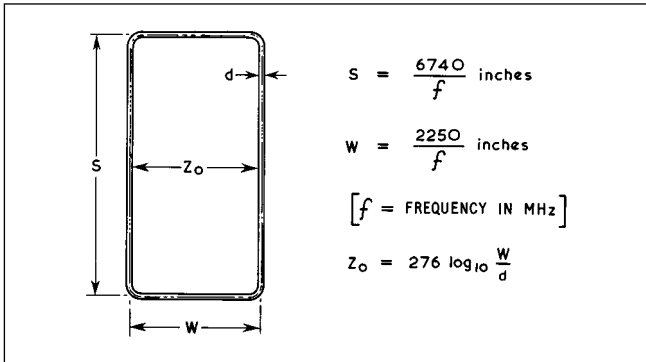

Fig 16.26: Development of the skeleton-slot radiator



**Fig 16.27: Dimensional relationships of a skeleton-slot radiator. Both S and W may be varied experimentally, and will not change the radiation characteristics of the slot greatly. See text**

section/transmission line (ie a delta match). Practical dimensions of a skeleton-slot radiator are given in Fig 16.27.

These dimensions are not critical, and may be varied over a modest range without affecting the radiating characteristics of the slot. However, the feed impedance is very sensitive to dimensional changes, and must be properly matched by altering the length and shape of the delta section after completing all other adjustments.

It is important to note that two sets of parasitic elements are required with a skeleton-slot radiator and not one set as with a true slot. One further property of the skeleton slot is that its bandwidth is greater than a pair of stacked dipoles. Radiation patterns and VSWR data for some typical slot-fed Yagi antennas are shown in Fig 16.9 earlier in this chapter. Details of a practical 'six-over-six' skeleton slot Yagi antenna are shown in Fig 16.28 with essential dimensions listed in Table 16.11.

**Skeleton Slot Yagi Arrays**

Skeleton-slot Yagi arrays may be stacked to increase the gain but the same considerations of optimum stacking distance as previously discussed apply. The centre-to-centre spacing of a pair of skeleton-slot Yagi arrays should typically vary between

Element	Length, in (mm)	Element spacing, in (mm)
A	34 (864)	A - B, 14.25 (362)
B	34 (864)	B - C, 14.25 (362)
C	34 (864)	C - D, 14.25 (362)
D	34 (864)	D - E, 34.25 (870)
E	40 (1016)	D - Slot, 14.5 (368)
Boom	70 (1720)	

**Table 16.11: Dimensions for six-over-six slot fed 145MHz Yagi**

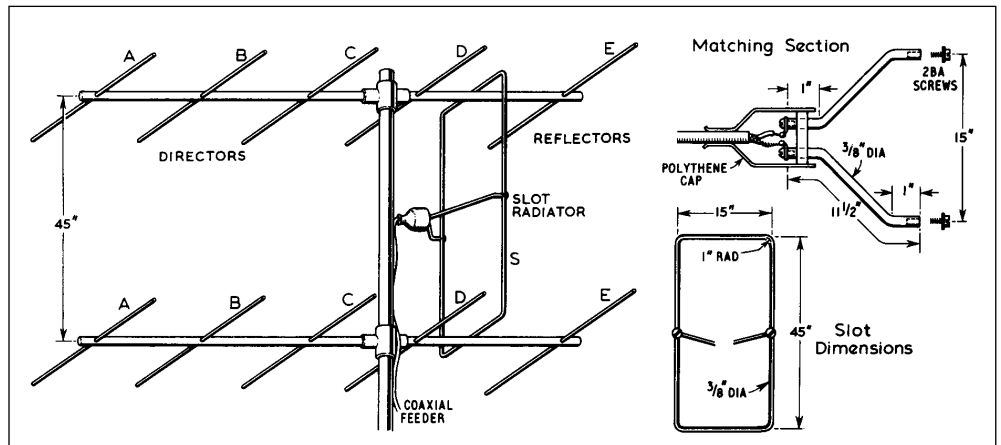

**Fig 16.28: Six-over-six skeleton slot fed Yagi antenna for 145MHz**

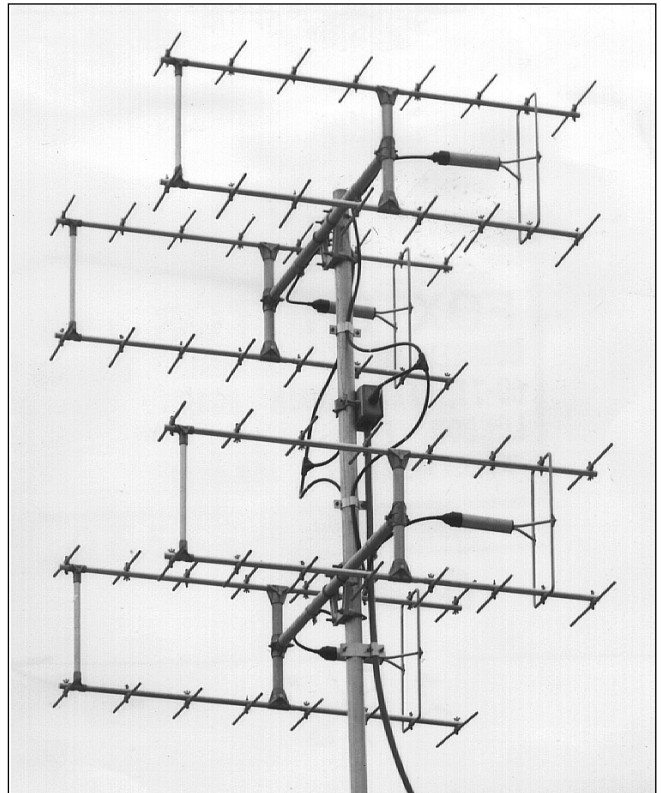

**Fig 16.29: A high gain 432MHz antenna consisting of four eight-over-eight slot-fed Yagi antennas arranged in a square formation**

$1\lambda$  and  $3\lambda$  depending on the number of elements in each Yagi array. A typical 4 x 4 array of 8-over-8 slot-fed Yagis for 432MHz is shown in Fig 16.29.

**Quadruple Quad for 144MHz**

This collapsible antenna was designed for portable use [20], but is equally useable as a fixed antenna for use indoors or in a loft, and can achieve gains of between 10 and 11dBi (8 - 9dBd) on 2 metres. It is effectively a stacked quad using mutual coupling instead of a phasing harness to excite the outer elements. Constructional details are shown in Fig 16.30. Each section has a circumference of around 1.04 wavelengths, which is not as would be expected for conventional quads. The dimensions are the result of experiments to obtain the best front to back ratio and least sensitivity to adjacent objects, which can be important for portable or loft operation, ensuring that the antenna will work without extensive adjustment. Note that the antenna was

**Fig 16.30: Quadruple Quad.** The match point xx should be found experimentally and will be approximately 200mm from the open end (*VHF Communications*)

designed for low-power (1 watt) operation; the ferrite bead must not be allowed to saturate magnetically, or harmonic generation may occur. The bead may also become hot and shatter. For higher power operation, ferrite rings could be considered for the balun transformer, or a sleeve balun constructed as appropriate.

**Yagi Antenna Mounting Arrangements**

The performance of Yagi antennas can be greatly degraded if they are not correctly installed and the feeder routed to minimise unwanted interaction with the antenna. Many commercial designs have fixed clamping positions which have been optimised to minimise coupling into the support mast. However, there are a number of precautions that can be taken when installing any Yagi antennas, whether operating in the same band as an array, or operating in several different bands.

Antenna performance may be completely destroyed if the mast is installed parallel, and through the Yagi antenna as in Fig 16.31a. The mast should be mounted at right angles to the antenna elements to minimise coupling between the elements and the mast, Fig 16.31c. If the antenna is to provide vertical polarisation, it should be offset from the main support mast with a stub mast if possible, Fig 16.31b. Mechanical balance can be restored (and the Yagi-mast separation increased) by using a symmetrical stub mast and a second antenna for the same band (bayed array), or for another frequency.

The mounting clamp should be placed midway between elements, and well away from the driven element. This is usually achieved by clamping near the mechanical balance point of the antenna. However, it is more important to keep the mast and clamp away from the adjacent elements than to mechanically balance

**Fig 16.31: Yagi mounting methods (a) the wrong way, antenna couples strongly with the mast, destroying performance (b) best arrangement for vertically polarised antennas, offset from the mast at least  $\lambda/4$  with a horizontal tube (c) mast should be fastened mid way between elements, but not next to the driven element (d) put highest frequency antenna at top of a multi-band stack**

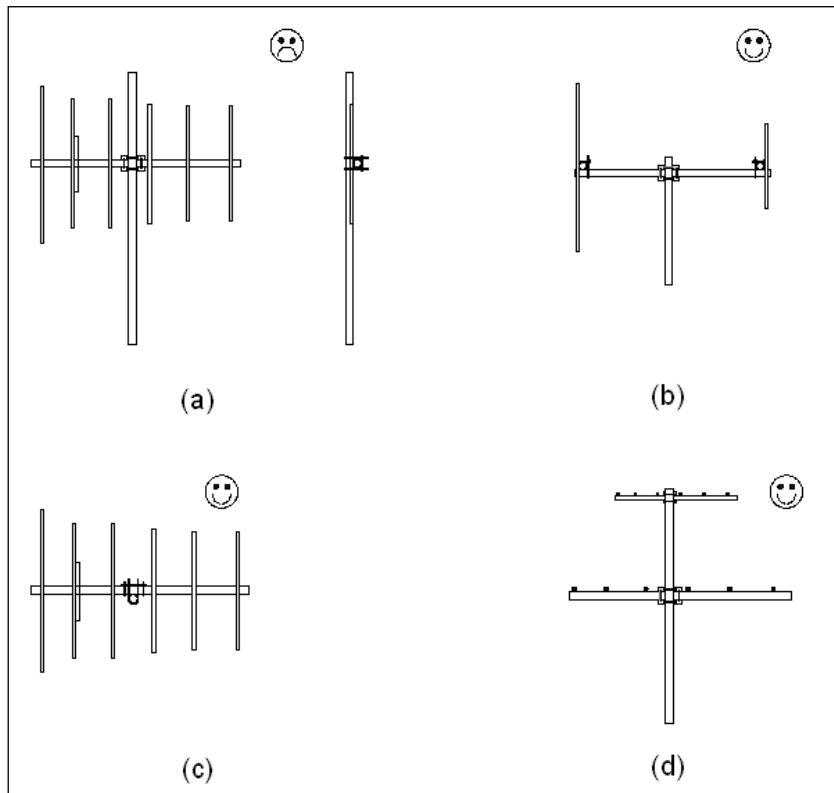
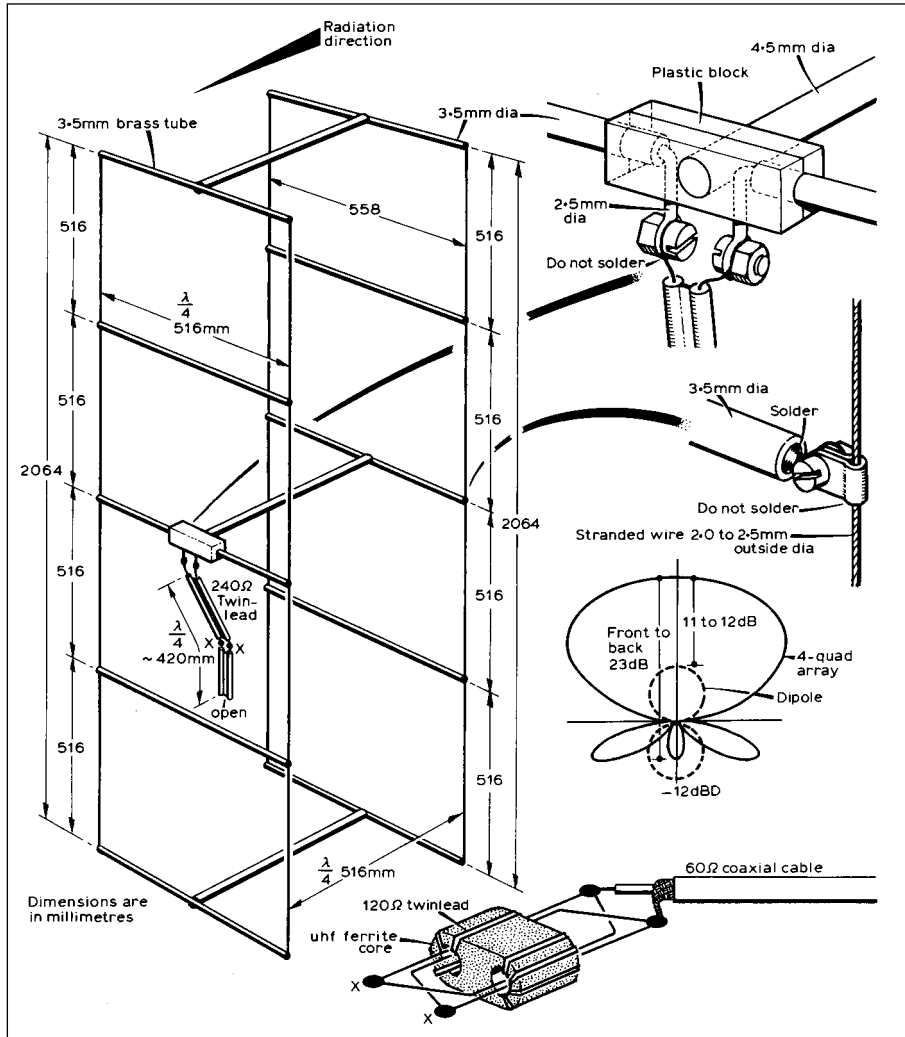

the antenna. In theory, the mast could be clamped to the antenna behind the reflector element(s). This is rarely done with antennas operating at wavelengths greater than 23cm because of mechanical constraints.

At 23cm and above, a 50mm (2in) pipe mast running through the antenna will seriously degrade its performance, even if the elements are at right angles to the pipe. Performance will not be so badly affected if the (horizontally polarised) antenna is right at the top of the mast, with the minimum amount of pipe required for clamping projecting through the elements. A smaller diameter pipe, eg 25mm (1in) for the mount will also reduce these effects, and is generally mechanically adequate to support higher frequency antennas.

The feed cable should be arranged to lie in a plane at right angles to the Yagi elements, or be taped below and along the boom until it can be run down the support mast. In the case of circularly polarised antennas, for example, crossed Yagi antennas fed in phase quadrature, the elements should be arranged at 45 degrees to the support mast when the antenna is viewed along its boom. There will be some degradation of circularity, but it can be minimised if the support mast is not an odd multiple of quarter wavelengths long. The feed cable should be taped to the boom and dressed on to the support mast with the minimum bend radius for which the cable is designed.

**Stacking Yagi Antennas for Different Bands**

The optimum spacing between identical antennas to create higher gain arrays is discussed earlier in the chapter. However, in many cases, it may be desired to put several antennas for different bands on a common rotating mast. If the antennas are all pointing in the same direction on the mast, they should be separated sufficiently to ensure that their effective apertures do not overlap (see formula earlier in this chapter) to avoid interaction and mutual degradation of their radiation patterns. To a first approximation, the antenna gain may be used in place of the directivity in the formula. Yagi antennas may be stacked more closely together if alternate antennas point in directions at 90 degrees to each other. The separation may then be reduced so that the effective aperture of the lowest band antenna of any pair is not physically encroached by the higher frequency antenna.

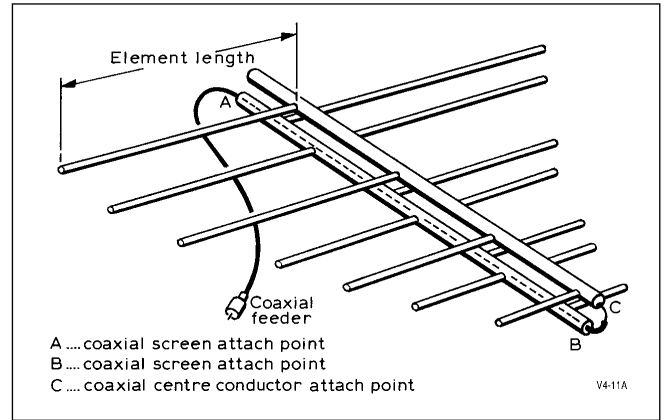

**Fig 16.32: Typical log-periodic antenna. Note that the bottom transmission line is fed from the coaxial outer while the top line is fed from the centre conductor (Ham Radio)**

Closer spacings may be possible without excessive interaction, but need to be investigated on a case by case basis using antenna modelling software or careful experiment.

Further information on antenna stacking can be found on G3SEK's web site [15].

**THE LOG PERIODIC ANTENNA**

The log-periodic antenna Fig 16.32 was originally designed and proven at the University of Illinois in the USA in 1955 [22]. Its properties are an almost infinite bandwidth, governed only by the number of elements used and mechanical limitations, together with the directive qualities of a Yagi antenna [23].

Table 16.12 and Table 16.13 show typical dimensions for element spacing and length for log-periodic arrays. These are derived from a computer-aided design produced by W3DUQ [23]. Other frequency bands can be produced by scaling all dimensions. The tabulated parameters have a 5% overshoot of the working frequency range at the low end and a 45% overshoot at the high-frequency end. This is done to maintain logarithmic response over the complete frequency range specified as the log-periodic cell is active over approximately four elements at any

Element	21-55MHz array						50-150MHz array						140-450MHz array					
	Length (ft)	Length (mm)	Diameter (in)	Diameter (mm)	Spacing (ft)	Spacing (mm)	Length (ft)	Length (mm)	Diameter (in)	Diameter (mm)	Spacing (ft)	Spacing (mm)	Length (ft)	Length (mm)	Diameter (in)	Diameter (mm)	Spacing (ft)	Spacing (mm)
1	12.240	3731	1.50	38.1	3.444	1050	5.256	1602	1.00	2.54	2.066	630	1.755	535	0.25	6.7	0.738	225
2	11.190	3411	1.25	31.8	3.099	945	4.739	1444	1.00	2.54	1.860	567	1.570	479	0.25	6.7	0.664	202
3	10.083	3073	1.25	31.8	2.789	850	4.274	1303	1.00	2.54	1.674	510	1.304	397	0.25	6.7	0.598	182
4	9.087	2770	1.25	31.8	2.510	765	3.856	1175	0.75	19.1	1.506	459	1.255	383	0.25	6.7	0.538	164
5	8.190	2496	1.25	31.8	2.259	689	3.479	1060	0.75	19.1	1.356	413	1.120	341	0.25	6.7	0.484	148
6	7.383	2250	1.00	25.4	2.033	620	3.140	957	0.75	19.1	1.220	372	0.999	304	0.25	6.7	0.436	133
7	6.657	2029	1.00	25.4	1.830	558	2.835	864	0.75	19.1	1.098	335	0.890	271	0.25	6.7	0.392	119
8	6.003	1830	0.75	19.1	1.647	500	2.561	781	0.50	12.7	0.988	301	0.792	241	0.25	6.7	0.353	108
9	5.414	1650	0.75	19.1	1.482	452	2.313	705	0.50	12.7	0.889	271	0.704	215	0.25	6.7	0.318	97
10	4.885	1489	0.75	19.1	1.334	407	2.091	637	0.50	12.7	0.800	244	0.624	190	0.25	6.7	0.286	87
11	4.409	1344	0.75	19.1	1.200	366	1.891	576	0.50	12.7	0.720	219	0.553	169	0.25	6.7	0.257	78
12	3.980	1213	0.50	12.7	1.080	329	1.711	522	0.375	9.5	0.648	198	0.489	149	0.25	6.7	0.231	70
13	3.593	1095	0.50	12.7	0.000		1.549	472	0.375	9.5	0.584	178	0.431	131	0.25	6.7	0.208	63
14							1.403	428	0.375	9.5	0.525		0.378	115	0.25	6.7	0.187	57
15							1.272	388	0.375	9.5	0.000		0.332	101	0.25	6.7	0.169	52
16													0.290	88	0.25	6.7	0.000	
Boom	25.0	7620	2.0	50.8	0.5	12.7	16.17	5090	1.5	38.1	0.5	152	5.98	1823	1.5	38.1	0.5	152

**Table 16.12: Spacing and dimensions for log-periodic VHF antennas**

Element	Length		Diameter		Spacing	
	(ft)	(mm)	(ft)	(mm)	(ft)	(mm)
1	0.585	178	0.083	2.1	0.246	75
2	0.523	159	0.083	2.1	0.221	67
3	0.435	133	0.083	2.1	0.199	61
4	0.418	127	0.083	2.1	0.179	55
5	0.373	114	0.083	2.1	0.161	49
6	0.333	101	0.083	2.1	0.145	44
7	0.297	91	0.083	2.1	0.131	40
8	0.264	80	0.083	2.1	0.118	36
9	0.235	72	0.083	2.1	0.106	32
10	0.208	63	0.083	2.1	0.095	29
11	0.184	56	0.083	2.1	0.086	26
12	0.163	50	0.083	2.1	0.077	23
13	0.144	44	0.083	2.1	0.069	21
14	0.126	38	0.083	2.1	0.062	19
15	0.111	34	0.083	2.1	0.056	17
16	0.097	30	0.083	2.1	0.000	0
Boom	1.99	607	0.5	12.7		

**Table 16.13: Spacing and dimensions for log-periodic UHF antenna (420 - 1350MHz)**

one specific frequency. The logarithmic element taper ( $\alpha$ ) is  $28^\circ$  for all three antennas. They have a forward gain of 6.55dBd, with a front-to-back ratio of typically 15dB and a VSWR better than 1.8:1 over the specified frequency range.

Construction is straightforward. The element lengths for the highest-frequency antenna allow for the elements to be inserted completely through the boom, ie flush with the far wall. The two lower-frequency antennas have element lengths calculated to butt flush against the element side of the boom, and a length correction factor must be added to each element if through-boom mounting is used.

The supporting booms are also the transmission line between the elements for a log-periodic antenna. They must be supported with a dielectric spacer from the mast of at least twice the boom-to-boom spacing. Feed-line connection and the arrangement to produce an 'infinite balun' is shown in Fig 16.33. Any change in the boom diameters will require a change in the boom-to-boom spacing to maintain the transmission line impedance. The formula to achieve this is:

$$Z_0 = 273 \log_{10} D/d$$

where  $D$  is the distance between boom centres and  $d$  the diameter of the booms. Mounting arrangements are shown in Fig 16.33. The antenna can be oriented for either horizontal or

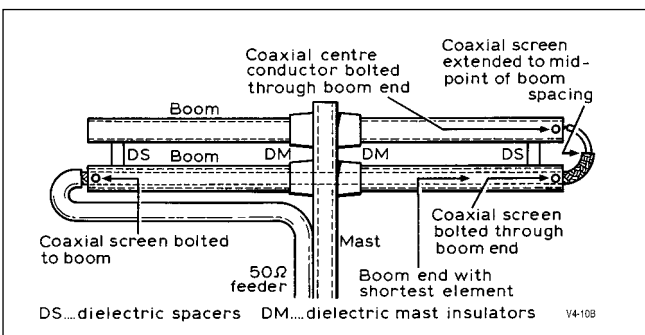

**Fig 16.33: Log-periodic antenna mast mounting and feeder arrangements (Ham Radio)**

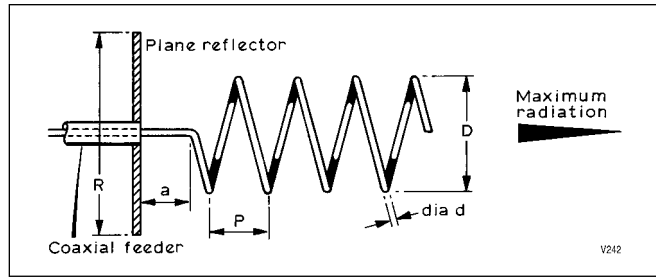

**Fig 16.34: The axial mode helix antenna. The plane reflector may take the form of a dartboard type wire grid or mesh. The dimensions given in Table 16.13 are based on a pitch angle of 12 degrees. The helix tube or wire diameter is not critical, but it must be supported by low loss insulators**

vertical polarisation if a non-conductive mast section is used. The horizontal half-power beamwidth will be typically  $60^\circ$  with a vertical half-power beamwidth of typically  $100^\circ$ .

### THE AXIAL MODE HELIX

The axial mode helix antenna provides a simple means of obtaining high gain and a wide-band frequency characteristic. When the circumference of the helix is of the order of one wavelength, axial radiation occurs, ie the maximum field strength is found to lie along the axis of the helix. This radiation is circularly polarised, the sense of the polarisation depending on whether the helix has a right or left-hand thread. The polarisation can be determined by standing behind the antenna. If a clockwise motion would be required to travel along the helix to its far end, the helix will generate and receive Right Hand Circularly Polarised (RHCP) waves.

A helix may be used to receive plane or circularly polarised waves. When signals are received from a transmitting helix care must be taken to ensure that the receiving helix has a 'thread' with the same hand of rotation as the radiator, or significant signal will be lost due to *polarisation mismatch*.

The properties of the helical antenna are determined by the diameter of the helix  $D$  and the pitch  $P$  (see Fig 16.34). It is also dependent on radiation taking place all along the helical conductor. The gain of the antenna depends on the number of turns in the helix.

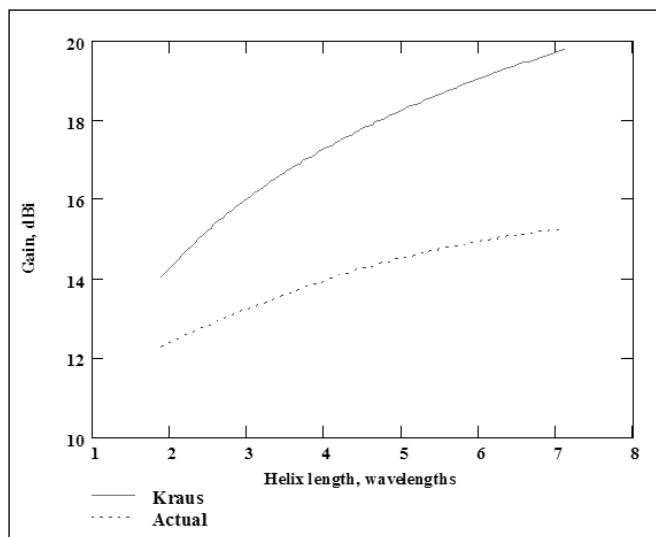

**Fig 16.35: Kraus's theoretical gain and realisable gain for a helix antenna of different lengths. The antenna has a circumference of  $1.06\lambda$  and  $\alpha = 13^\circ$**



The diameter of the reflector  $R$  should be at least  $\lambda/2$ , with the diameter of the helix  $D$  about  $\lambda/3$  and the pitch  $P$  about  $0.24\lambda$ . A detailed description of the way in which the antenna radiates, and the relationships between pitch and diameter for different antenna characteristics are described by its inventor, J D Kraus in [25].

A helix of this design will have a termination / feed impedance of about 140 ohms. A 50-ohm impedance can be obtained by shaping the last quarter turn from the feedpoint to lie close to the reflector by reducing the pitch of the helix over the last turn.

Gain of the antenna is proportional to the number of turns in the helix, and may be enhanced slightly by tapering the open end towards the centre.

At higher frequencies an additional 1dB can be obtained by replacing the flat reflector with a cup that encloses the first turn. However, the theoretical gains published by Kraus and others are optimistic. (Fig 16.35) Maximum realisable gains are given by following formula for helix lengths between 2 and 7 wavelengths.

$$G_{max} = 10.25 + 1.22L - 0.0726L^2 \text{ dBi}$$

where  $L$  is the length of the antenna in wavelengths.

A typical antenna with a seven turn helix has a gain of approximately 12dBi over a 2:1 frequency range. To fully utilise this gain it is necessary to use a circularly polarised antenna (eg a helix of the same sense) for both transmission and reception. If a plane-polarised antenna, such as a dipole, is used there will be an effective loss of 3dB due to polarisation mismatch. General dimensions for helix antennas are shown in Table 16.14.

### A Practical Helix Antenna for 144MHz

The greatest problem to be overcome with this type of antenna for 144MHz operation, with a helix diameter of  $24\frac{1}{2}$ in, is the provision of a suitable support structure.

Fig 16.36 shows a general arrangement in which three supports per turn (120° spacing) are used. Details of suitable drilling of the centre boom are given in Fig 16.37.

The helix may be made of copper, brass, or aluminium tube or rod, or coaxial cable. This latter alternative is an attractive material to use, being flexible with the braid 'conductor' weather-proofed. If coaxial cable is used the inner conductor should be

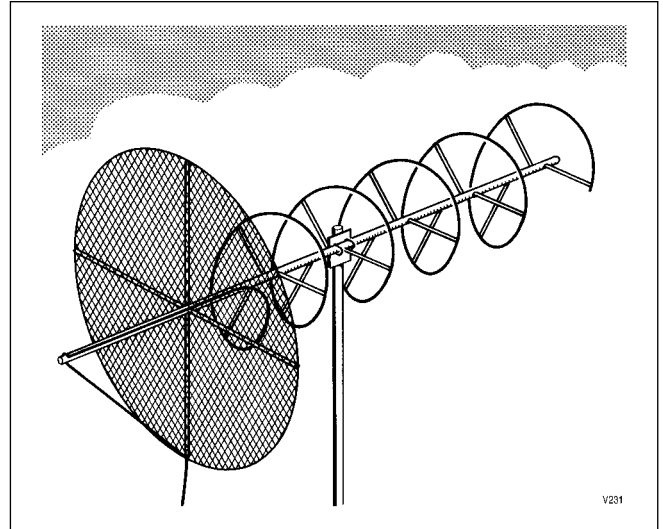

Fig 16.36: General arrangements of support structure for a five-turn helical antenna for 144MHz. The antenna is right hand circularly polarised

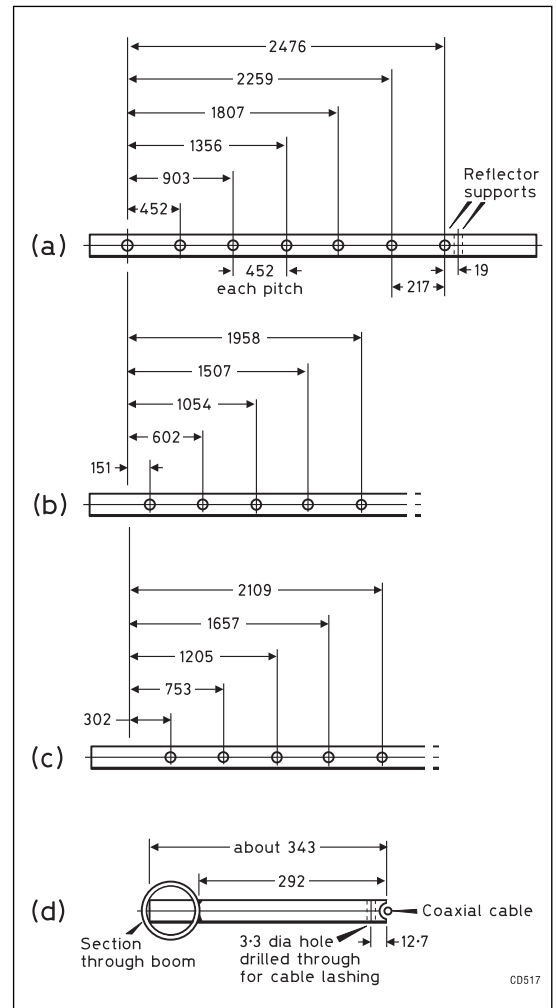

Fig 16.37: First side drilling dimensions for the 144MHz band helix antenna (a) reflector holes are drilled at right angles; (b) and (c) are drilled at intervals of 120 and 240 degrees respectively from (a); (d) cutting and filing dimensions for the element stand-offs

Band	Dimensions				
	D	R	P	a	d
General	0.32	0.8	0.22	0.12	
144MHz	25.5 (648)	64 (1626)	17.75 (450)	8.75 (222)	0.5 (12.7)
433MHz	8.75 (222)	22 (559)	6 (152)	3 (76)	0.375-0.5 (4.8 - 12.7)
1296MHz	3 (76)	7 (178)	2 (50)	1.125 (28)	0.125-0.25 (3.2-6.4)
Turns	6	8	10	12	20
Gain	12dBi	14dBi	15dBi	16dBi	17dBi
Beamwidth	47°	41°	36°	31°	24°

Dimensions in inches, millimetres are given in brackets. The gain and beamwidth of the helical antenna are dependent upon the total number of turns as shown above.

Bandwidth =  $0.75$  to  $1.3\lambda$   
circumference

Feed impedance =  $140 \times \frac{\lambda}{\text{circumference}}$  ohms

(Note:  $\lambda$  and circumference must be in the same units.)

Beamwidth (degrees) =  $\frac{12,300}{\text{No of turns}}$

Table 16.14: General dimensions for 144, 433 and 1296MHz helix antennas

connected to the outer at each end, and the jacket well sealed to prevent moisture ingress and corrosion.

The reflector is located at a distance  $a$  behind the start of the first turn, and is supported by crossed supports from the central boom. Material for the reflector can be any kind of metal mesh such as chicken netting. Radial spokes alone are not sufficient and will reduce the gain by 1-2dB, unless connected together with wires in dartboard fashion.

It is not essential that the central boom should be constructed of non conductive material. Metal booms may be used provided that they are centrally placed along the axis of the helix. This can lead to a simple construction using square aluminium tubing, as sold for self-construct shelving in some DIY centres. Corners and end fixtures can also be used to fasten the boom rigidly to the reflector without having to resort to machining or fabricating brackets.

A square section also simplifies the mounting of the insulators, which can be made from Delrin or other plastic rod, and secured through the boom by a long screw or bolt with a single hole at the far end through which to thread the helix. The number of insulators will depend upon the rigidity of the helix material. At 433MHz, supports every 1.25 turns are adequate for a helix made from copper tubing.

Although probably too heavy for 144MHz designs, copper tubing for small-bore central heating is suitable for 433MHz helices. It is readily obtainable in DIY centres in malleable coils that can be easily shaped over a suitable former. Draw a line with a wax pencil or paint along adjacent turns whilst they are still on the former, which if sized correctly, will allow the turns to be drawn out to the correct positions whilst the marks remain in a straight line. This helps considerably when ensuring the turns diameter and pitch are maintained along the length of the helix. The ends of the tube should be hammered flat and soldered up to prevent the ingress of water.

The last fractional turn of the helix closest to the reflector should be brought very close to the reflector as it approaches the connector, to bring the impedance of the helix to 50 ohms. Helix antennas for higher frequencies are easier to construct than Yagi antennas of comparable gain and require little adjustment. Detailed instructions for building 435MHz and 1296MHz helix antennas for satellite communications have been published in [26] and [27].

## HAND-HELD AND PORTABLE ANTENNAS

### Normal Mode Helix

The normal mode helix antenna comprises a length of spring wire wound such that the diameter of the spring is less than  $0.1\lambda$ , and typically of order  $0.01\lambda$ . Such antennas become resonant when their axial length is around  $0.1\lambda$ , and can be designed to offer manageable impedances at the base. The resonance occurs over a relatively narrow band, and is heavily influenced by any jacket or sleeve fitted over the helix, and by the nature of the groundplane (if any) against which it is fed. The current distribution along the length of the helix is similar to that of a whip antenna, but compressed into the much shorter length of the helix.

For hand-held radios, the length of the helix is dimensioned such that the current distribution is similar to that expected on a  $5/8\lambda$  whip, ie the current maximum occurs about one third of the overall height above the feed point. This helps to maximise the radiation efficiency of the antenna, whilst also minimising effects of the variability of the ground plane (hand held radio) and body proximity on both the input impedance and radiating efficiency.

**Fig 16.38: A typical commercial helical antenna with screw mounting facility**

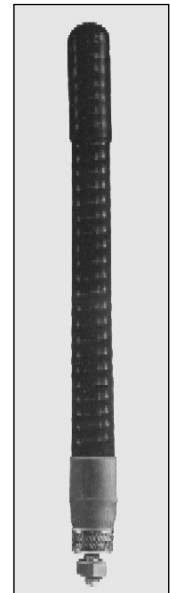

A  $3/4\lambda$  whip over a moderate ground plane has a resistive match very close to 50 ohms. If this whip is coiled into a helical spring it will match to approximately 50 ohms and resonate at a lower frequency, partly due to capacitance between the coil turns.

If the spring is trimmed to the original frequency the result will be an antenna of about  $0.1\lambda$  overall height. The actual length of wire is between  $1/2\lambda$  and  $5/8\lambda$  at the working frequency.

Electrically it is still a resonant  $3/4\lambda$  antenna. Near-base capacitance also modifies the matching under certain frequency and ground plane conditions.

If the turns are very close together, the helical antenna will resonate at a frequency approaching the axial length, because of strong coupling between the turns. There is an optimum 'spacing' between turns for best performance. A 145MHz helical antenna typically has a spacing between turns equal to twice the diameter of the wire used.

The helical whip is very reactive off-resonance. It is very important that it is resonated for the specific conditions that prevail in its working environment.

Fortunately, it is often only necessary to change the number of turns to resonate the spring over such diverse conditions, ie a large ground plane or no ground plane at all. The resistive part of the impedance can vary between 30 and 150 ohms at the extremities.

Under typical 'hand-held' conditions (Fig 16.38), although to a small extent depending on the frequency of operation, the spring can offer something close to a 50-ohm impedance match. Fig 16.39 shows the number of turns required for a typical 9mm diameter helix for  $3/4\lambda$  resonance.

As the helical is reduced in length two effects occur. First, the radiation resistance is lower than the equivalent linear whip so the choice of a good conducting material is important to reduce resistive losses.

A plain steel spring compared with a brass or copper-plated helix can waste 3dB of power as heat. Secondly, the physical aperture of the helical whip is around one third that of a  $\lambda/4$  whip, which would imply a loss of 4.77dB.

Results obtained from copper-plated, Neoprene-sheathed helical antennas, correctly matched to a hand-held transmitter at 145MHz, provided signals at worst 3dB and at best +1dB compared with a  $\lambda/4$  whip. A  $\lambda/4$  whip with minimal ground plane would offer signals about -6dB compared to a  $\lambda/2$  dipole.

A helical antenna, resonant and matched, on a  $\lambda/2$  square ground plane can give results 2-3dB below a  $\lambda/2$  dipole. An alternative arrangement using a bifilar-wound helix gives identical results (within 0.2dB) to a  $\lambda/2$  dipole.

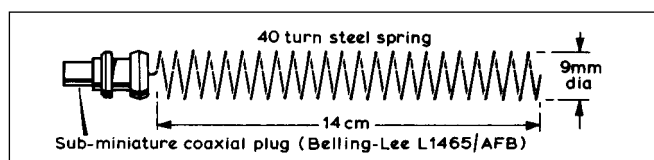

**Fig 16.39: Details of a home-made helical whip for 145MHz. A BNC plug could also be used**

### A Vertical Dipole for Portable Operation

A practical dipole for portable operation on in either the 2m or 6m band [28] is shown in Fig 16.40. The upper and lower sections together form a centre-fed half wavelength dipole. The feed cable is wound into a resonant choke to present a high impedance to the lower end of the dipole to reduce currents on the outside of the feed cable. Constructed from RG58C/U cable or similar, the antenna can be rolled up into a small space for travel, then unrolled and suspended from a suitable support for operation.

3870mm of RG8C/U cable is required for 145MHz operation. 470mm of the outer sheath and braid is stripped off, leaving the insulator and inner core to form the upper radiator. Measure out the length of the lower radiator from where the insulator is exposed to mark the starting point of the choke. Wind 4.6 turns on 32mm diameter PVC pipe to form the choke.

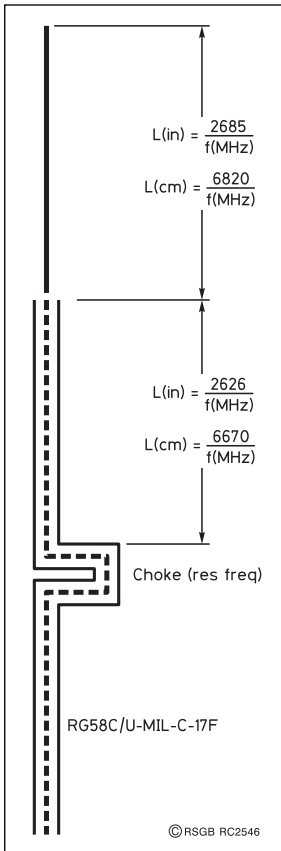

Fig 16.40: The "feedline vertical" antenna

### HB9CV Mini Beam

The HB9CV mini-beam, because of its compact and straightforward construction, is suitable for both base station and portable use, and can be particularly useful in confined spaces such as lofts. Similar antennas are the lazy-H and ZL Special often used on the HF bands. The HB9CV version has one or two mechanical advantages that make it particularly suitable for VHF portable use. Fig 16.41 [29] and Fig 16.42 show two methods of construction for the HB9CV antenna. Note that a series capacitor of 3-15pF is required to adjust the gamma match/phasing combination to a VSWR of about 1.3:1 referred to 50Ω. The element spacing, and in particular the transmission line spacing (5mm in this case), is critical for optimum impedance matching and phasing, and therefore gain and front-to-back ratio.

The principle of operation is as follows. If two dipoles are close spaced (typically 0.1 - 0.2λ) and fed with equal currents with a phase difference corresponding to the separation of the dipoles, 'end-fire' radiation will occur along the line between the dipoles in one direction, and almost no radiation will occur in

Feeding the cable through holes in the centre of end caps on the pipe allows the antenna to hang tidily. A ring terminal or solder tag soldered to the tip may be used for hoisting the antenna on nylon line or similar.

Tuning should be done outdoors, with the antenna positioned well away from objects that could affect the resonant frequency. Trim short pieces from the tip of the antenna to obtain a VSWR better than 1.3:1 (in 50 ohms) across 144 - 146MHz. If a longer feeder is required, the length below the choke should be a multiple of one half wavelength (680mm to compensate for the velocity factor of the dielectric) to minimise de-tuning.

A 6m variant can be constructed using 7280mm of RG58C/U cable. 11.8 turns of cable should be wound on a 50mm diameter PVC tube to form the choke. Any additional feeder should be a multiple of 1980mm.

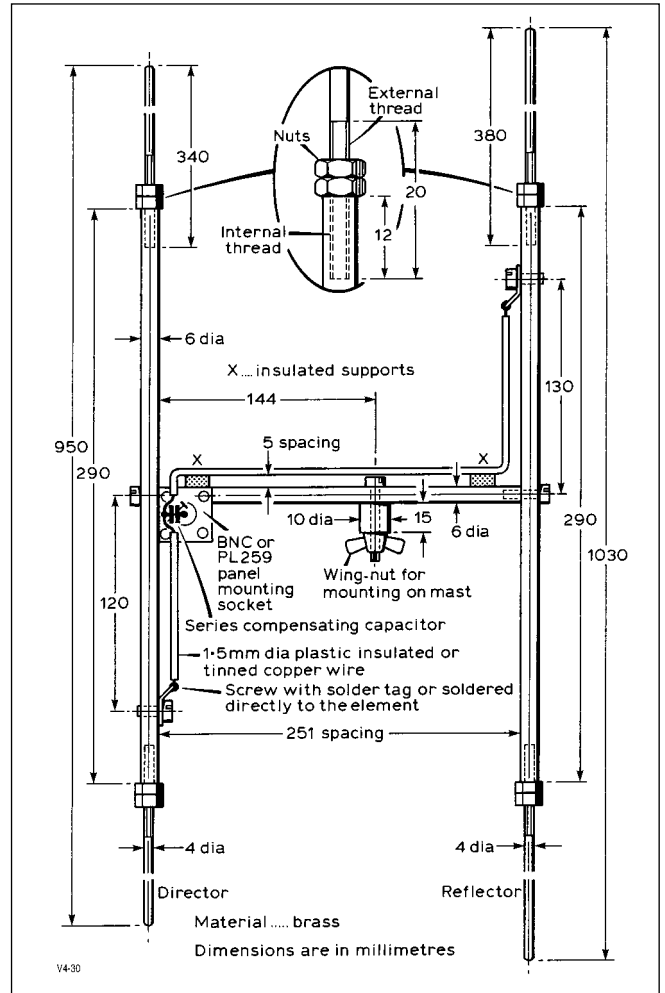

Fig 16.39: A collapsible HB9CV antenna for the 144MHz band (VHF Communications)

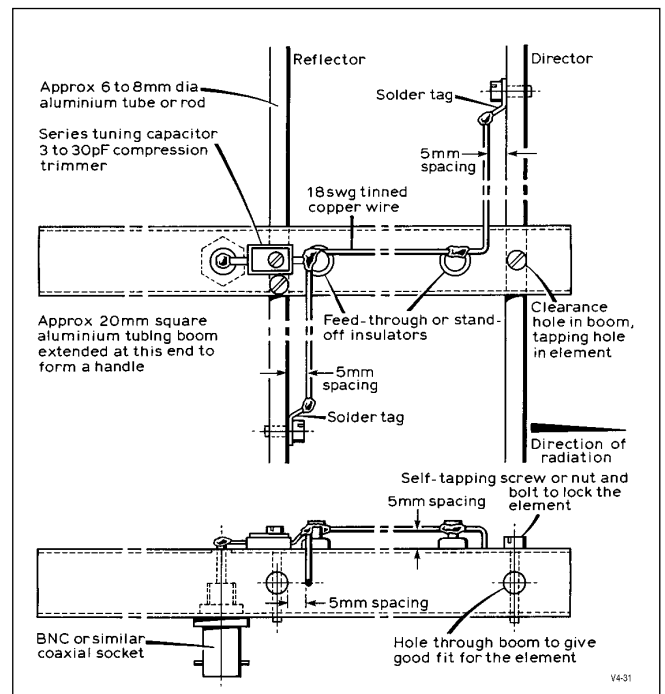
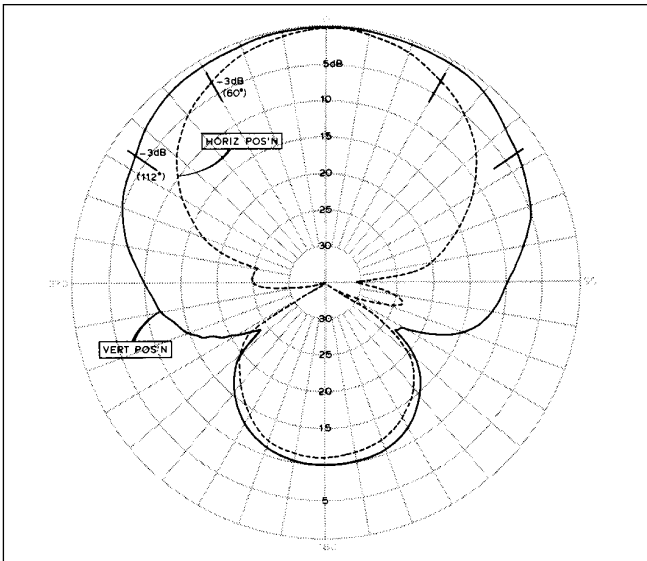

Fig 16.42: Alternative boom and feed arrangement for the 144MHz HB9CV antenna



**Fig 16.43: HB9CV antenna radiation patterns. Antenna 10m above ground**

the reverse direction as explained earlier in this chapter in the section on arrays.

The different element lengths found on most HB9CV antennas improve the VSWR bandwidth, not the directivity as might at first be thought by comparison with a two element Yagi antenna.

The end at which the beam is fed defines the direction of radiation. A theoretical gain in excess of 6dBd should be possible. Depending on construction techniques, gains of 4 to 5dBd with front-to-back ratios of 10 to 20dB tend to be obtained in practice.

The radiation patterns shown in **Fig 16.43** and **Fig 16.44** are for the antenna of Fig 16.41. This antenna has a typical gain of 5dBd. Note the difference obtained when mounted at 10m (30ft) above the ground compared with hand-held measurements 1-2m above the ground. The latter height is typical for the antenna being used for direction finding.

**Lightweight HB9CV for 144MHz**

The compact size of the HB9CV makes it eminently suitable for direction finding contests, EMC or interference probing, and portable work. The need for a very lightweight directional antenna for EMC investigations led to the design shown in **Fig 16.45**.

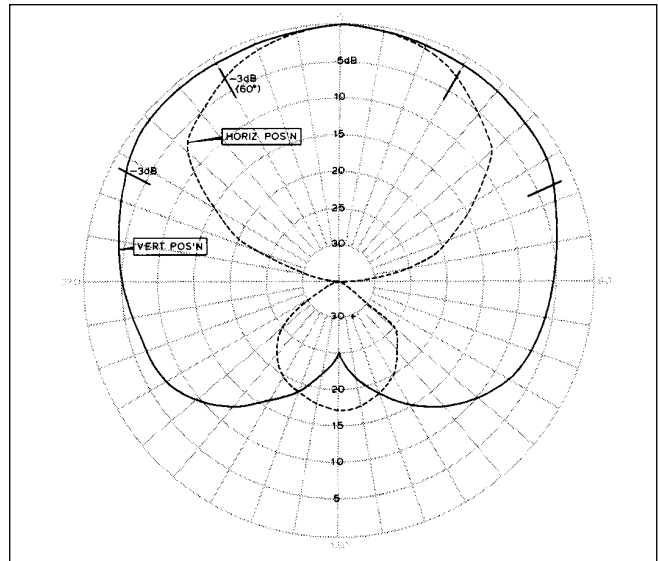
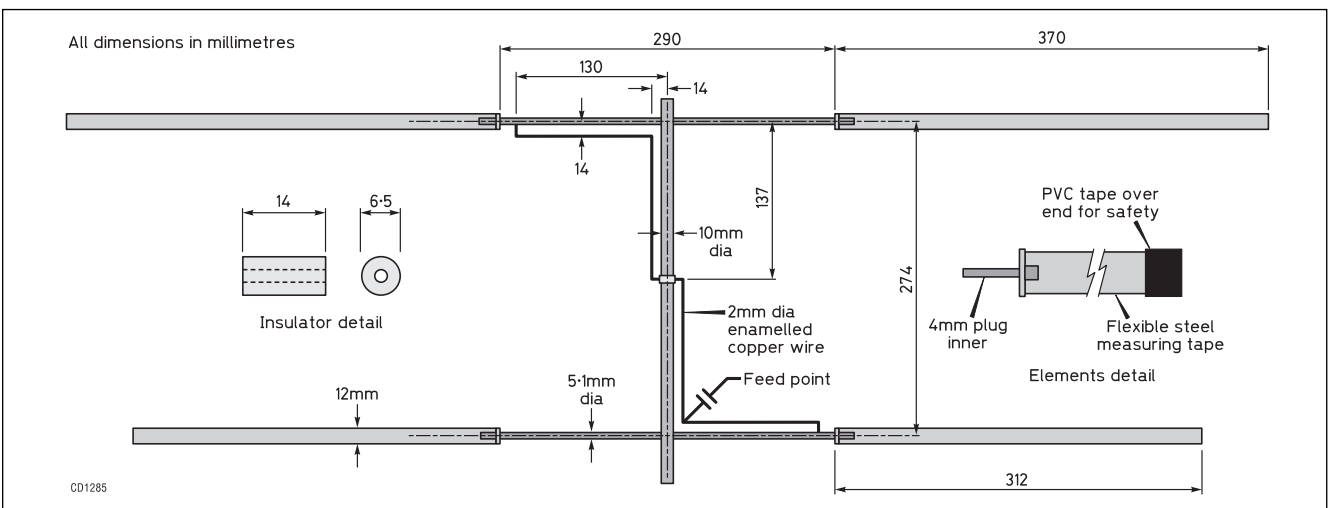

**Fig 16.44: HB9CV antenna radiation patterns. Antenna hand-held, 1-2 metres above ground**

The boom and stub elements are made from thin walled brass tubing, soft soldered or brazed together. The removable elements are made from an old 12mm wide spring steel measuring tape soldered on to 4mm 'banana' plugs, although replacement tapes without housings can be purchased from good tool shops. The sharp ends must be protected by at least one layer of PVC tape or similar material. The feedline insulator where it passes through the boom can be made from Delrin or a scrap of solid polythene insulator from coaxial cable. The series matching capacitor in the example shown is 13pF, but should be adjusted for minimum VSWR, and the end of the coaxial cable and exposed connection to the capacitor should be sealed with silicone rubber compound if outdoor use is envisaged. The antenna can be supported on a simple wooden mounting using small 'Terry' spring clips to grip the boom.

**MOBILE ANTENNAS**

The choice of an antenna for mobile VHF and UHF use is dependent on several factors. As the frequency increases the aperture of the antenna decreases, and propagation losses increase. This means that higher antenna gains are required for UHF than VHF to overcome the losses of both aperture and path.



**Fig 16.45: Construction details of lightweight HB9CV antenna for 144MHz**

Considerable reduction of beamwidth in the vertical plane is needed to achieve gain whilst retaining an omnidirectional pattern in the horizontal plane. A compromise has to be made to obtain maximum gain in the best direction that gives minimum disruption of signals when mobile.

For example an omnidirectional antenna of 6dBd gain will have a typical half-power beamwidth in the vertical plane of under 30 degrees. The narrow disc shaped beam that is produced can result in considerable variation in transmitted and received signal strength as the vehicle or antenna tilts. This is particularly the case where signals are reflected from nearby objects.

The choice of polarisation is not only dependent on compatibility with stations being received and the optimum for the propagation path. The aesthetics, mechanical complexity, safety and the mounting position of the antenna on the vehicle must be considered.

High-gain, relatively large, antennas suffer gain reductions with probable loss of omnidirectionality if the antenna is not roof mounted. The difference in mounting an antenna on the wing or boot of a car compared with mounting it on the top dead centre of the car roof can be at least 3dB. Variation of the radiation pattern can occur due to close-in reflections and surface-wave effect across the vehicle, as well as restriction of the 'line of sight'.

**Normal Mode Helix on a Groundplane**

The normal-mode helical (spring) antenna, when vehicle mounted, offers a gain approximately 2 to 3dB less than a dipole, but the overall height is reduced to the order of  $0.1\lambda$ . An acceptable match to 50 ohms can often be obtained by simply adjusting its resonant length. Alternatively, a small inductance or capacitor across the base or an input tapping on an 'earthed' helical, as shown in Fig 16.46, will provide the required matching. The design and limitations of the normal mode helix were discussed earlier in this chapter under the heading of hand-held antennas.

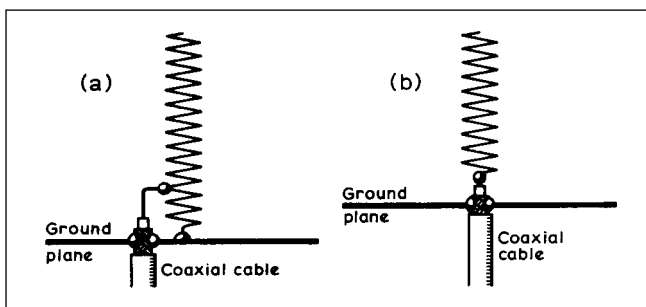

Fig 16.46: Two ways of feeding a helical antenna on a ground plane: (a) shunt feed, (b) series feed

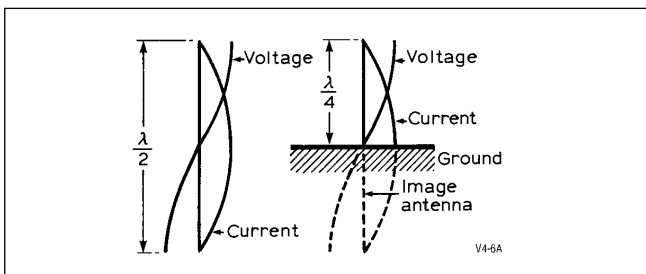

Fig 16.47: The  $\lambda/2$  antenna and its grounded  $\lambda/4$  counterpart. The missing  $\lambda/4$  can be considered to be supplied by the image in ground of good conductivity

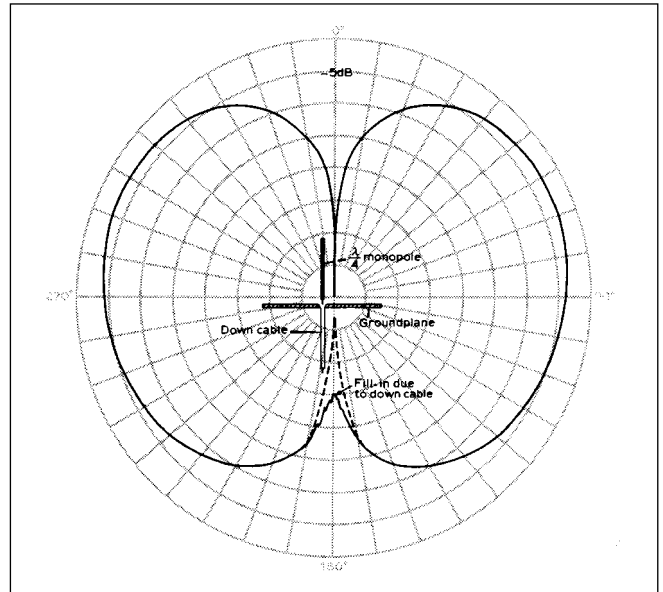

Fig 16.48: Decibel radiation pattern of a  $\lambda/4$  monopole over a  $\lambda/2$  square groundplane at 145MHz

**Quarter-wave Whip**

This is the simplest and most basic mobile antenna. The image of the vertical  $\lambda/4$  section is 'reflected' in the ground plane, producing an antenna that is substantially the same as a dipole, provided that the ground plane is infinitely large and made of a perfectly conducting material (Fig 16.47). In this case, all of the radiation associated with the lower half of the dipole is radiated by the top half, resulting in a 3dB improvement in signal strength in a given direction for the same power input to the antenna.

In practice the size of the ground plane and its resistive losses modify the pattern. The full 3dB is never realised. Measurement of a 5GHz monopole on an aluminium ground plane of 40 wavelengths diameter showed a gain of 2.63dBd. Fig 16.48 and Fig 16.49 show optimum patterns of a  $\lambda/4$  whip measured on a ground plane of  $\lambda/2$  sides and  $1\lambda$  sides. Although the pattern is raised from the horizontal, on a medium

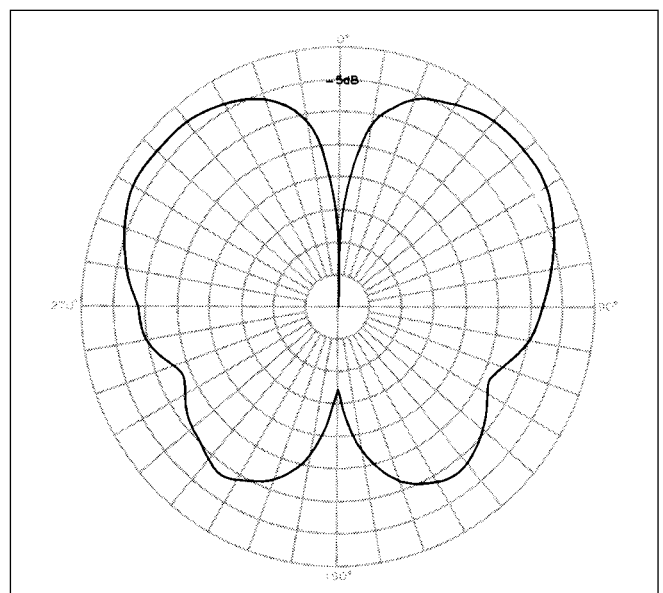
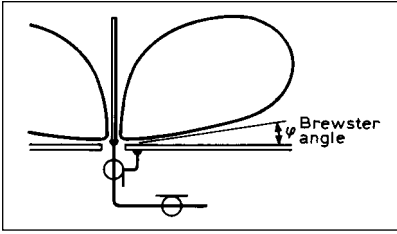

Fig 16.49: Decibel radiation pattern of a  $\lambda/4$  monopole over a  $1\lambda$  square groundplane at 145MHz



**Fig 16.50: Radiation pattern of whip on large groundplane showing elevation of the main lobe**

sized ground plane the loss of horizontal gain is relatively small (20° and 1dB at 0° in Fig 16.48, but 40° and 6dB at 0° in Fig 16.49). However, as the groundplane size increases, the main lobe continues to rise until the situation of Fig 16.50 pertains.

When a vertical radiator is mounted over a ground plane as described, the input impedance is typically halved. For the  $\lambda/4$  whip or monopole, the input impedance is typically  $36\Omega - jX$ , that is to say approximately half the resistance of the dipole but with an additional reactive component. With 50 ohm cable impedance this would produce a standing wave ratio at the antenna base of about 1.5:1.

The simplest way to overcome this mismatch is to increase the length of the whip to produce an inductive reactance to cancel the capacitive reactance normally obtained. In practice an increase in length also raises the resistive value of the whip and a close match can usually be obtained to a 50-ohm cable.

At VHF (145MHz) the  $\lambda/4$  whip's simplicity and limited height (about 49cm/19in) is often an accepted compromise. At 70MHz the physical dimensions (about 102cm/40in) are such that size is the usual limit, making a  $1/4\lambda$  whip preferable to a 'gain' antenna. The effective aperture of the antenna at this frequency is compatible with path loss conditions, and the ground-plane size, when roof-mounted on a vehicle, is such that the radiation angle is fairly low. However, the shape of the radiation pattern can result in a gain reduction of 3dB to each side of the vehicle.

**Half-wave and Five-eighths-wave Antennas**

Ground-plane techniques described for the  $1/4\lambda$  whip can be used for vertical gain antennas. If the  $1/2\lambda$  dipole is extended in length, maximum forward gain (before the pattern divides into

several lobes) is obtained when the dipole is about  $1.2\lambda$ . This corresponds to a maximum length of  $5/8\lambda$  for a ground-plane antenna.

A natural extension to the  $1/4\lambda$  whip is the  $1/2\lambda$  whip. However, such a radiator fed against a ground plane has a high input impedance. On the other hand, a  $3/4\lambda$  radiator fed against a ground plane has a resistive input close to 50 ohms. Unfortunately, the resultant radiation pattern in the elevation plane is less than optimum.

If the  $1/2\lambda$  whip could be made to look like a  $3/4\lambda$  radiator then it would be possible to obtain a 50-ohm resistive input. A series coil at the ground-plane end of a  $1/2\lambda$  radiator can be used to resonate at  $3/4\lambda$ , but the input is still of fairly high impedance and reactive. If, however, the coil is shorted to the ground plane, tapping up the coil will provide the required match/input point. The addition of a capacitor in series with the input will compensate for the remaining reactive component. Fig 16.51 shows details of such an antenna.

As the aperture of the antenna has been doubled compared with the  $1/4\lambda$  whip, the gain over the whip approaches 3dB. Achievement of this figure requires minimum losses in the radiating element, ie it must be copper-plated or made from a good conducting material.

The maximum radiator size of  $5/8\lambda$  for a single-lobe pattern can also make use of the impedance characteristics of the  $3/4\lambda$  radiator. Construction is simpler than for a  $1/2\lambda$  antenna. If the radiating element is made  $5/8\lambda$  long, and a series coil is placed at the ground plane end, an input impedance very close to 50 ohms can be obtained. With correct materials a gain close to 4dBd can be achieved from the further increase in effective aperture. The radiation pattern is raised more than that of a  $1/2\lambda$  antenna, so the improved gain of the  $5/8\lambda$  may not always be realised. However, the simplicity of construction is an advantage.

Fig 16.52 gives details of the series  $5/8\lambda$  whip. One other advantage of this antenna is that over a wide range of mounting and ground-plane conditions it will self-compensate for impedance and resonance changes. It is preferable for both the  $1/2\lambda$  and  $5/8\lambda$  antennas to be 'hinged', particularly if roof-mounted, to enable folding or 'knock down' by obstructions, eg trees and garages.

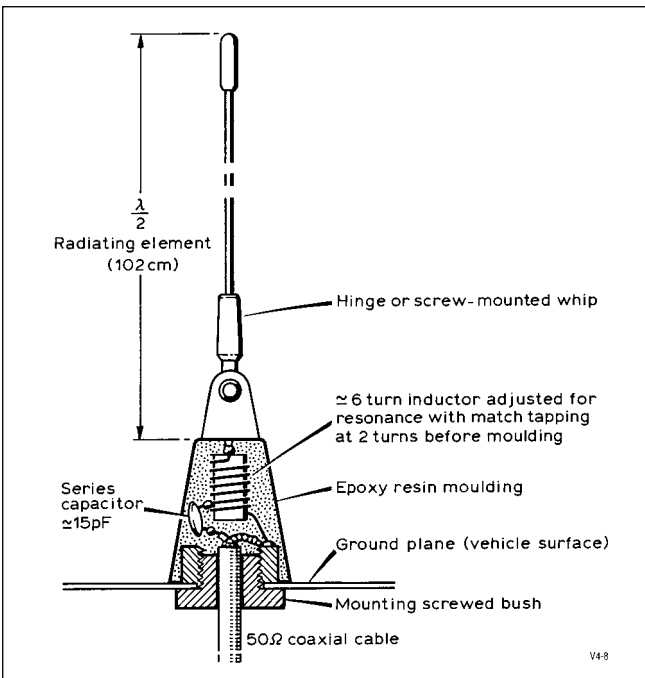

**Fig 16.51: A home-built mobile antenna and mount**

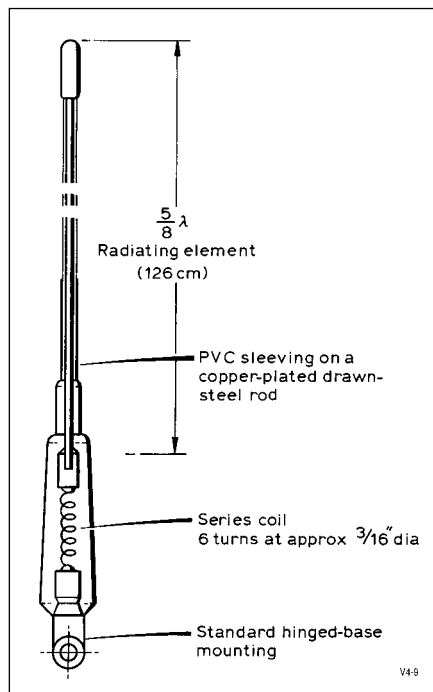

**Fig 16.52: Typical commercial  $5/8\lambda$  mobile antenna and mount**

Various gain figures have been reported for the  $5/8\lambda$  whip antenna. Unfortunately not all antennas use optimum materials. Resistive steel wires or rods produce heating loss, and the use of a glass fibre-covered wire changes the resonant length by as much as 20%. The radiator therefore has to be cut shorter than  $5/8\lambda$ , with an accompanying loss of aperture.

The construction of the series coil is important. Movement of the coil turns will change the antenna's resonance, giving apparent flutter. Some transceivers with VSWR-activated transmitter close-down will be affected by change of resonance of the antenna. This can make the power output of the transmitter continually turn down or be switched off, producing what appears as extremely severe 'flutter' on the transmission.

Several of the ' $5/8\lambda$  ground-plane antennas' discussed in various articles are in fact not truly antennas of this nature.

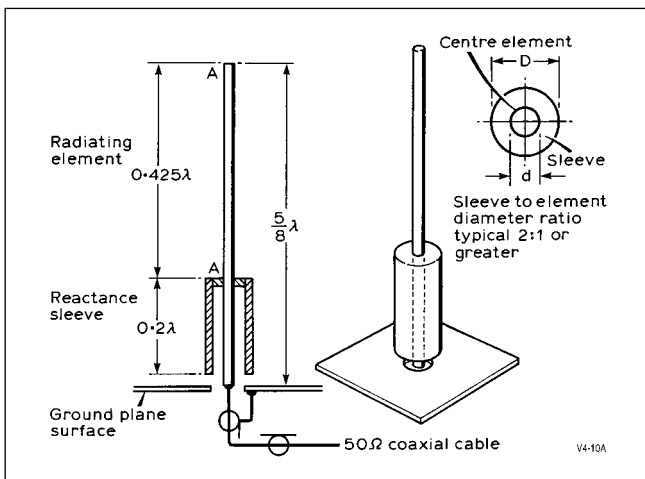

Fig 16.53: The reactance-sleeve  $5/8\lambda$  monopole (Ham Radio)

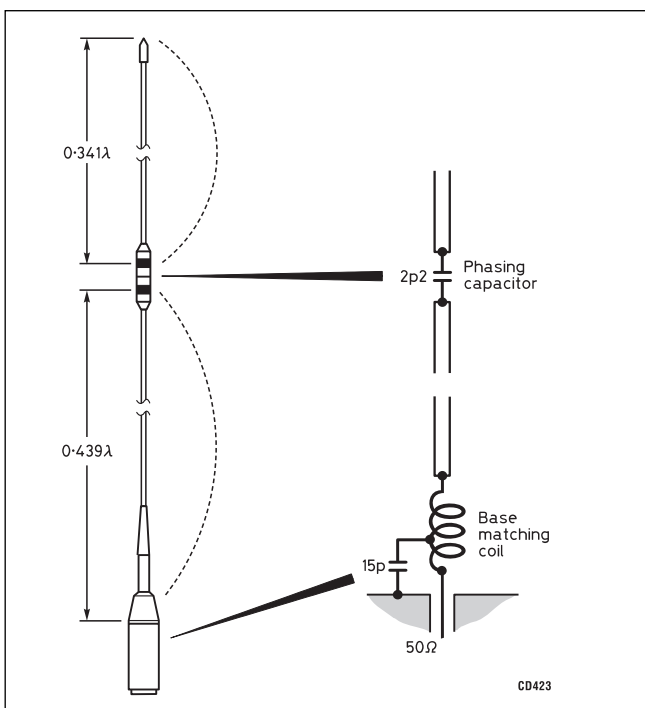

Fig 16.54: The  $7/8\lambda$  whip antenna. This is effectively two shortened half-wave elements in series with a series phasing capacitor between them. The assembly shown is that of a commercial form of the antenna. The dotted lines show the approximate current distribution

One of these devices worth considering for its own merits is that shown in Fig 16.53. It consists of a  $5/8\lambda$  vertical element with a reactive sleeve of  $0.2\lambda$  at the ground-plane end. The gain obtained from this antenna is typically 1.8dBd. As can be seen, the actual radiating element A-A is shorter than a  $1/2\lambda$  antenna.

Another antenna family, with similar properties but different in construction, includes the 'J' and Slim Jim. These are described later in this chapter.

### Seven-eighths-wave Whip

This mobile antenna is derived from the Franklin collinear shown later in this chapter. It consists of two  $1/2\lambda$  elements coupled by a series 'phasing' capacitor. One effect of the capacitor is to resonate the combined elements at a lower frequency than that of a single  $1/2\lambda$  element. However, reducing the length of the top element tunes the arrangement back to the original frequency.

The base impedance above a perfect ground plane is 300-400 ohms with some capacitive reactance. A series loading coil in combination with an L-matching section gives a good match to 50-ohm coaxial feeder. The match is maintained with quite modest ground plane size ( $1/4\lambda$  radials or  $1/2\lambda$  diameter metal surface). This makes the  $7/8\lambda$  whip suitable for vehicle mounting or for use as a base-station antenna.

The final length of the two radiator elements is somewhat dependent on their diameters and the design of the series capacitor and matching unit. Fig 16.54 shows the general appearance and dimensions of a commercial version of the  $7\lambda/8$  whip, together with typical circuit components and current distribution in each element.

The theoretical gain of this antenna is 4.95dBi (2.8dBd) over a perfect ground plane. The professionally measured gain, with the whip on a 1m ground plane, was slightly over 4.7dBi for the full 144MHz band. The radiation pattern in the E (vertical) plane was predominantly a single lobe (torus/doughnut) peaking at  $4^\circ$  above the horizon and with a 3dB beamwidth of  $38.5^\circ$ .

## OMNIDIRECTIONAL BASE STATION ANTENNAS

### Omni-V for 144MHz (Horizontally Polarised)

This antenna consists of a pair of  $\lambda/2$  dipoles. The centres of the dipoles are physically displaced to produce quadrature radiation with the ends of each dipole supported on a  $\lambda/4$  shorted stub. A pair of Q-bars are tapped down the stubs to a point where the impedance is  $600\Omega$  as shown in Fig 16.55. When the two units are fed in parallel, they produce an impedance of  $300\Omega$  at the centre. A 4:1 balance-to-unbalance coaxial transformer is fitted to the centre point of the Q-bars to enable a  $75\Omega$  coaxial feeder cable to be used. A  $50\Omega$  feed can be arranged by repositioning the Q bars on the antenna stubs to provide a tap at  $400\Omega$  on the stubs.

This can be achieved by monitoring the VSWR on the coaxial feeder whilst adjusting the Q bar position by small but equal amounts on both stubs. The balun should, of course, be constructed from  $50\Omega$  coaxial cable (transforming from  $200\Omega$  in the balanced section) for a match to  $50\Omega$ . The general arrangement is shown in Fig 16.56 showing how the antenna may be arranged to give either an omnidirectional or bi-directional radiation pattern, and typical radiation patterns for either case are shown in Fig 16.57. Fig 16.58 shows the gain and VSWR of these antennas as a function of the centre frequency.

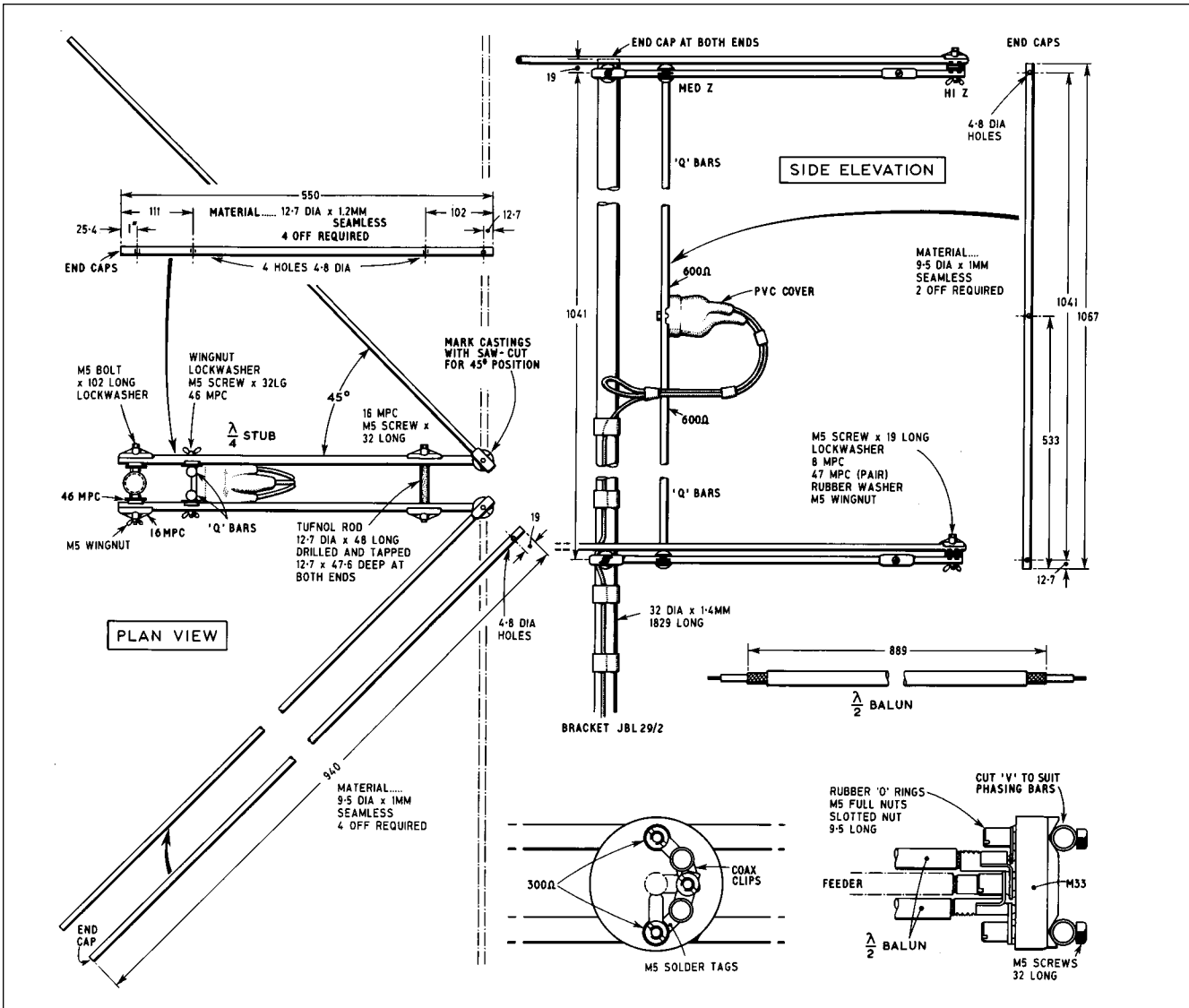

Fig 16.55: The mechanical construction of the Omni-V (dimensions are in millimetres)

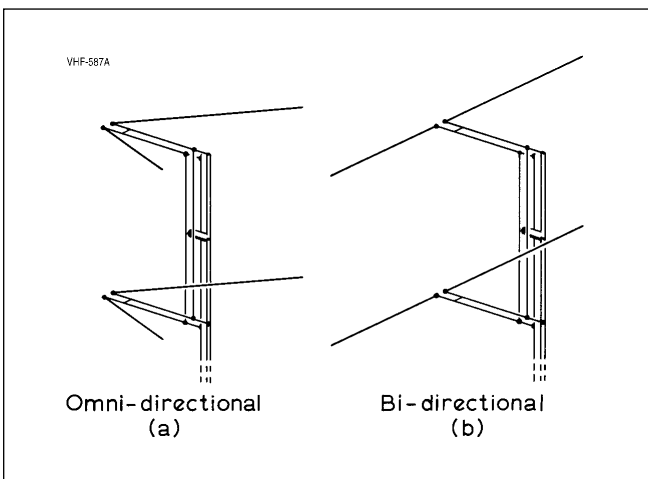

Fig 16.56: Formation of the Omni-V antenna

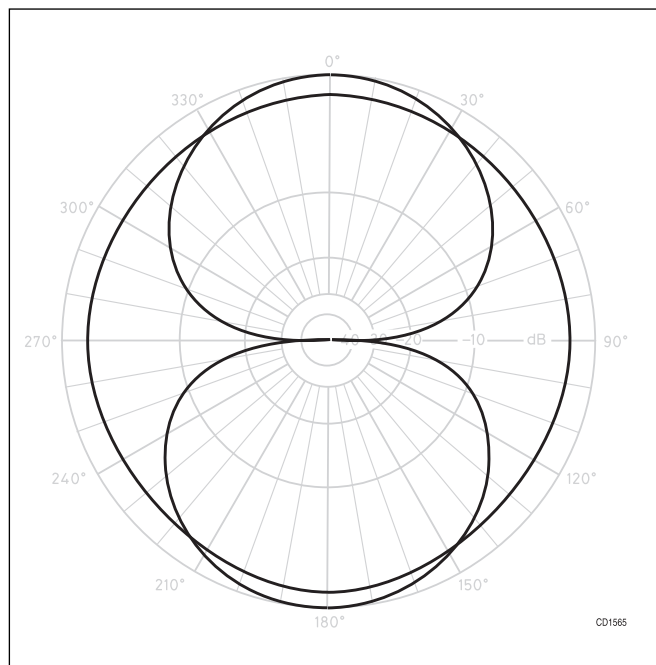

Fig 16.57: The horizontal radiation patterns for an Omni-V antenna and its bi-directional counterpart



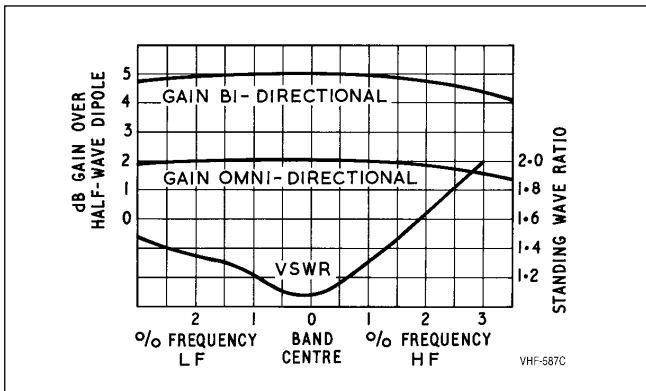

Fig 16.58: Chart showing gain and VSWR as a function of frequency for the Omni-V and the bi-directional antenna

### Quarter-wave Groundplane Antenna

This is one of the simplest omnidirectional antennas to construct and usually yields good results. However, some unexpected effects may occur when the antenna is mounted on a conductive mast, or if radio frequency current is allowed to flow on the outside of the feeder.

In its simplest form, the ground plane antenna comprises a quarter-wavelength extension to the inner of a coaxial cable, with several wires extending radially away from the end of the outer of the coaxial cable, Fig 16.59(a). The input resistance will be quite low, in the order of 20 ohms, although this may be transformed to a higher impedance by using a folded monopole radiator as shown in Fig 16.59(b).

Equal diameter elements provide a 4:1 step-up ratio to around 80 ohms, and a smaller diameter grounded leg can reduce the input impedance to 50 ohms.

The feedpoint impedance can be modified by bending the groundplane rods downwards from the horizontal, Fig 16.59(c). If the radiating element and the groundplane rods are all  $\lambda/4$  in length, the input resistance is approximately:

$$R = 18(1 + \sin\theta)^2 \text{ ohms}$$

where  $\theta$  is the groundplane rod angle below the horizontal, in degrees. A 50 ohm resistance is achieved when  $\theta$  is 42 degrees.

The ends of the groundplane rods are sometimes joined together with a conductive ring to provide additional mechanical stability. The ring increases the electrical size of the groundplane, and the length of the radials can be reduced by about 5%.

The few rods forming the groundplane usually do not prevent current flowing on any conductive supporting mast, or on the outside of a coaxial feeder. The mast or feeder can become a long radiating element which may enhance or destroy the radiation pattern of the antenna, dependent upon the magnitude and phase of the mast currents relative to that on the antenna. An example of this is shown in Fig 16.60(a), where the monopole and groundplane is mounted on a  $5\lambda$  mast (about 10 metres). The corresponding radiation patterns without mast or cable influences are shown in Fig 16.60(b). The effects of ground reflections have been ignored in both cases.

Some antenna designs make use of these currents to enhance the gain of the monopole, and sometimes have a second set of groundplane rods further down the mast, tuned to present a high impedance to reduce currents flowing below that point. The mast currents can be reduced a little by using more radials in the groundplane or extending their length to around  $0.3\lambda$ .

An open circuited choke sleeve can be more effective than radial wires for mast current control. This technique is used in the skirted antenna described later in this chapter.

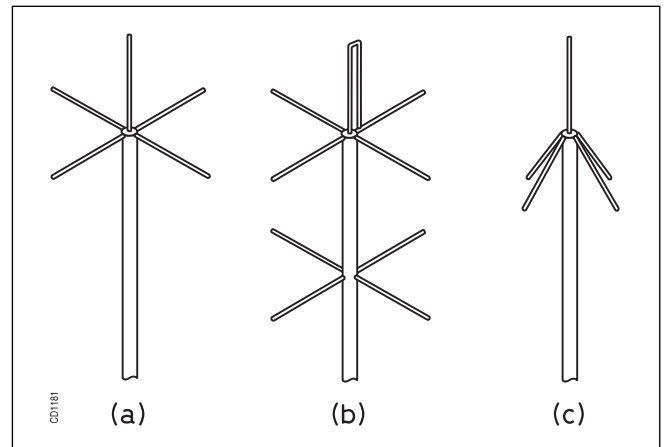

Fig 16.59: Quarter wave groundplane antennas

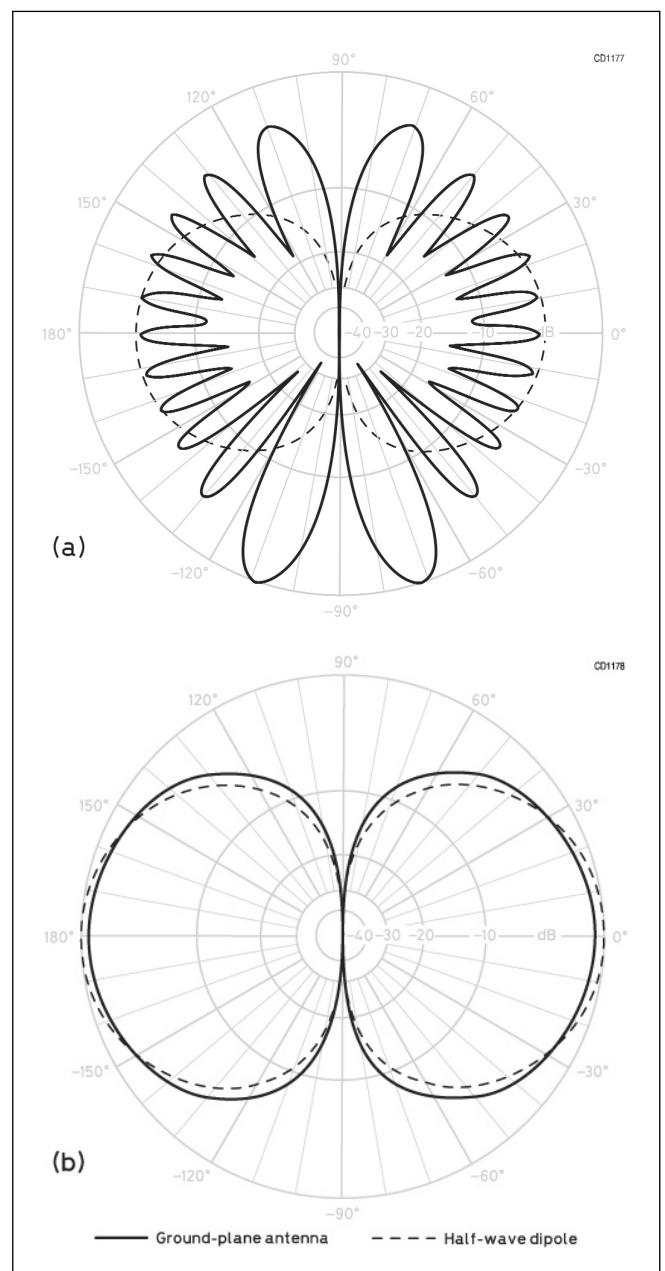
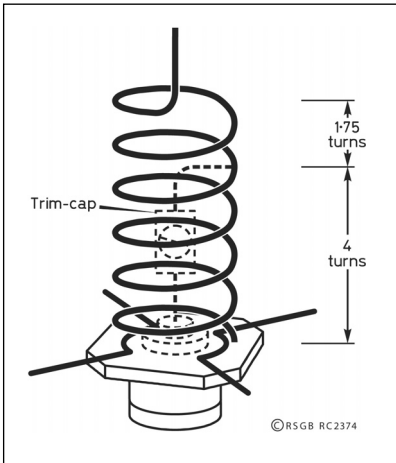
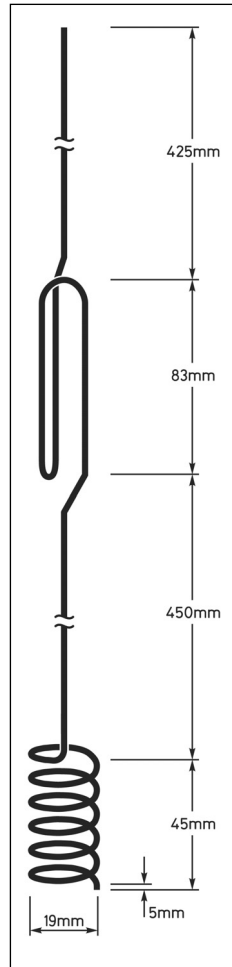

Fig 16.60: Radiation patterns of quarter-wave groundplane antenna, (a) with and (b) without a metallic mast

**Fig 16.61: Shape and dimensions of the radiator wire**



**Fig 16.62: Matching section and resonant groundplane radials**



Copper or brass mounting tube, 28mm OD x 220mm
PVC tube, 32mm OD, 28mm ID, x 1.2m
Jubilee clip, 32mm, preferably stainless steel
N-type 50Ω socket, PTFE dielectric, with square flange
Brass rod or tubing, 3mm OD x 720mm for radials
Bare or enamelled copper wire, 2mm (14SWG) 1.6m
Copper/brass tube or inner from connector block to butt-joint radiating elements (discard screws)
Tubular trimmer capacitor, 10pF or RG58 cable per Figure 61. Ensure that the capacitor can handle the transmitter power safely.
Silicone rubber sealing compound or bathroom sealant

**Table 16.145: Materials required for 145/435MHz omni antenna**

**Fig 16.63: Details of the coaxial socket and attachment of radials**

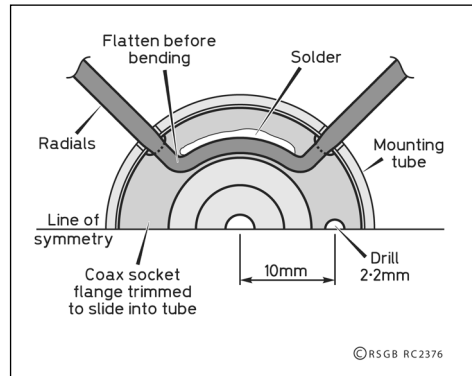

**Dual-band 145/435MHz Whip**

This base station antenna, devised by Bert Veuskens, PA0HMV acts as an end fed antenna on 145MHz with a gain of 0dBd, and two stacked  $5\lambda/8$  radiators with a gain of about 5dBd at 435MHz [30]. The radiator is made from 2mm copper wire, formed as shown in Fig 16.61. The coil at the base and a series capacitor provides the matching network at 145MHz. The folded stub section at the centre ensures the upper and lower  $5/8\lambda$  sections radiate in phase at 435MHz. A groundplane comprising four short radials resonant at 435MHz is fixed to the input connector, see Fig 16.62. No groundplane is required for operation at 145MHz, although the coaxial feed can be coiled close to the connector to choke off any current on the outside of the cable. The whole assembly is fitted inside a section of PVC tube for support and protection from the weather.

**Assembly**

A list of materials is given in Table 16.15. The corners of the coaxial socket are filed off to make it a snug fit in the 28mm copper pipe, and a hole is required for the earthy end of the matching coil as shown in Fig 16.63. The radials should be cut slightly too long to allow for trimming after assembly. A jig to hold the radials and connector in place during soldering is essential, and can be made from a piece of chipboard. After soldering, each radial should be trimmed to 173mm measured from the centre of the socket.

The rotor terminal of the trimmer capacitor, or the centre conductor of the RG58 coaxial cable capacitor (Fig 16.64) should be soldered to the centre pin of the connector next. Prepare the matching coil by straightening and stretching 60cm of the antenna wire. If enamelled wire is used, scrape off the enamel

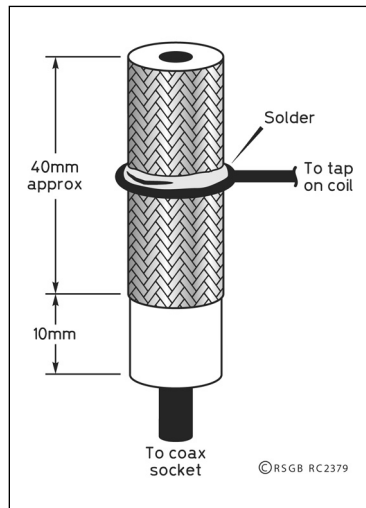

(left) Fig 16.64: RG58 coaxial cable capacitor. Note that the length may need to be adjusted for best match

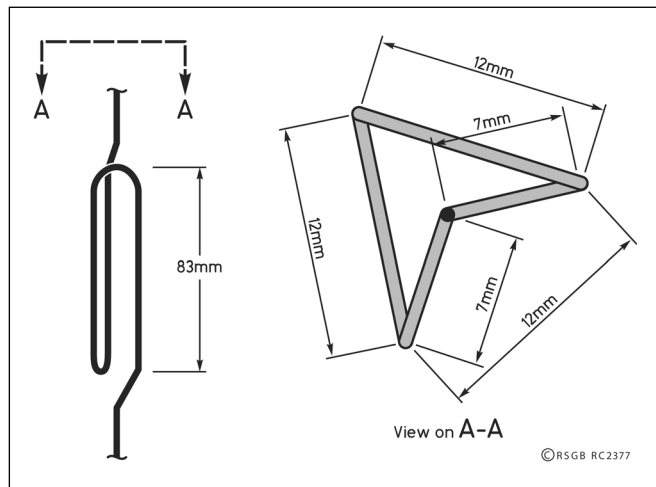

(below) Fig 16.65: Phasing stub bending detail

at one end and at the capacitor tapping point before winding up and shaping on a 19mm former of tube, rod or dowel as shown in Fig 16.62. Solder the end of the coil into the hole drilled in the flange of the coaxial socket and connect the free end of the matching capacitor to the coil, four turns above the soldered end. Approximately 200mm of the lower radiator should be projecting upwards, coaxially with the coil.

With the remaining wire, shape the phasing section as in Fig 16.65 using a 9.5mm drill bit as a former. Trim the lower wire end so that it makes up the 450mm length shown in Fig 16.61 with the wire on the coil when the ends are butted together. Prepare a polystyrene foam disc to centre the wire within the PVC support tube and slide onto the radiator wire below the phasing stub.

Butt-splice the two wires together by soldering them into a short piece of copper tubing or the inner part of a small cable connector with the screws removed.

Cut the top wire to 460mm. Fit a second foam centering disk on to the top wire. Four slots, 90 degrees apart, 7mm deep and 4mm wide are cut at one end of the copper pipe to clear the groundplane radials. This pipe will be used to clamp the finished antenna to the top of its mast with U-bolts and saddles.

**Tuning**

Pass a short 50-ohm cable through the copper pipe and connect it to the N socket. Push the pipe over the socket until the ground-plane radials are resting in the bottom of the four slots in the tube.

Set up the antenna without its cover tube well clear of objects that could de-tune it, but low enough for the top to be accessible. Trim the top element for minimum VSWR in the 70cm band

(right) Fig 16.66: Mounting tube and PVC cover details showing slots to clear radials



Fig 16.67: The finished antenna installed on a mast

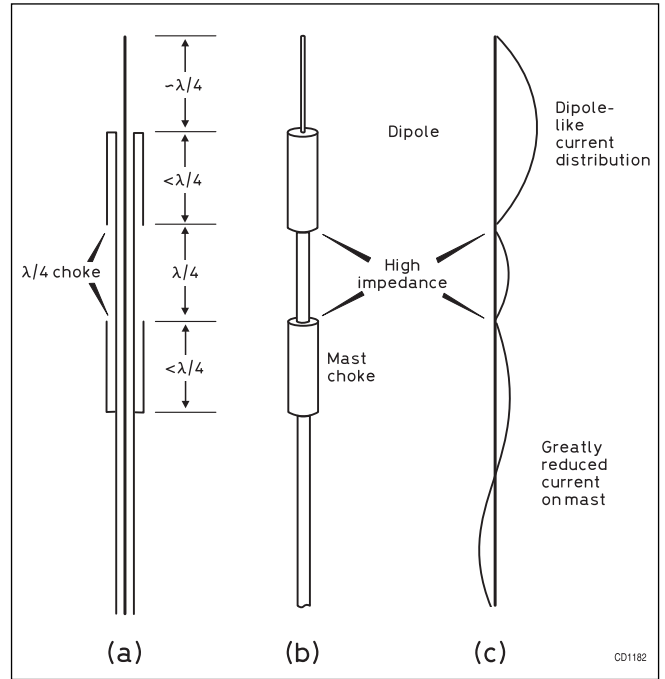
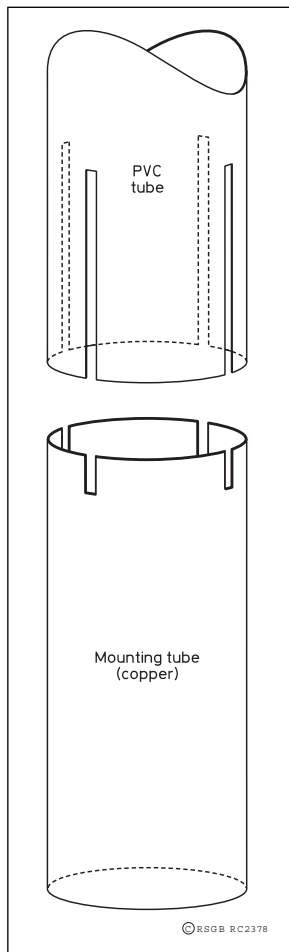

Figure 15.68: Skirted dipole antenna with mast choke

at a frequency 3MHz higher than required, eg 438MHz for 435MHz operation. The PVC cover tube will reduce the frequency by this amount when it is installed.

Fix the two centering discs in place with a drop of epoxy glue, at 170mm below the end of the top wire and halfway between the top of the coil and the bottom of the phasing stub for the lower wire.

Slide the PVC cover tube (Fig 16.66) over the antenna until the radials are fully seated in the slots, check that the minimum VSWR is below 1.5:1 and at the desired frequency in the 70cm band. Raise the PVC tube just enough to allow access to the trimmer/cable capacitor and adjust for minimum VSWR at 145MHz.

Push the PVC tube down again and secure with the Jubilee clip below the radials. Cap and seal the top and weatherproof the slots with sealant to keep rain out, whilst leaving a hole to prevent condensation from being trapped. The finished antenna is shown in Fig 16.67.

**The Skirted Dipole Antenna**

The skirted dipole antenna (Fig 16.68) does not require ground-plane radials, and can be mounted in a cylindrical radome for better appearance and lower wind induced noise. The skirt forms the lower part of a half wave dipole, and being one quarter wavelength long, presents a high impedance at its lower end, reducing unwanted currents on the mast. The current is further reduced by a second choke, with its open, high impedance end placed one quarter wavelength below the dipole skirt for best effect. The radiation pattern of this antenna closely resembles that of a half-wave dipole in free space.

**Gain Sleeve Dipole**

The gain sleeve dipole (Fig 16.69) is derived from the 1.8dBd shunt-fed  $5/8\lambda$  antenna described in the section on mobile antennas.

The radiating element B-B is a 1 element fed part way along its length with a  $0.2\lambda$  series short circuited stub to provide the transformation to 50 ohms and phasing. The impedance of asymmetrical antennas was investigated by R W P King [31],

Fig 16.69: Gain sleeve dipole

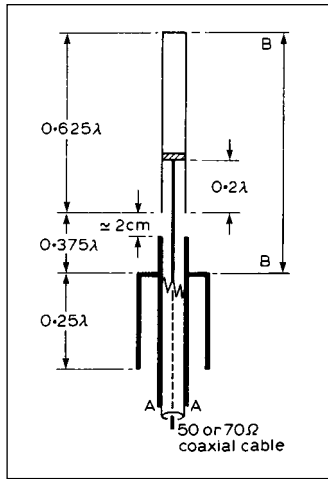

and has a number of applications in the design of ground-plane antennas with elevated feedpoints. Having approximately twice the aperture of the  $\lambda/2$  dipole, a gain of typically 2.5-3dBd is achieved. Mechanical construction is open to interpretation but 'beer can' or plastic water pipe formats offer two solutions. Note that the mounting point should be at A-A and not on the  $0.25\lambda$  sleeve.

**The Discone**

The discone is often used where a single omnidirectional antenna covering several VHF/UHF bands is required. A single antenna is capable of covering the 70, 144 and 432MHz bands or 144, 432 and 1296MHz. However, as the antenna can operate over roughly a 10:1 frequency range, it will more readily radiate harmonics present in the transmitter output. It is therefore important to use a suitable filter to provide adequate attenuation. The radiation angle tends to rise after the first octave of frequency and this is the normal acceptable working range. If correctly constructed, a VSWR of less than 2:1 can be obtained over the octave range. One characteristic of the basic discone is a very sharp deterioration of the VSWR at the lowest frequency of operation.

The discone consists of a disc mounted above a cone, and ideally should be constructed from sheet material. However, with only a little loss of performance the components may be made

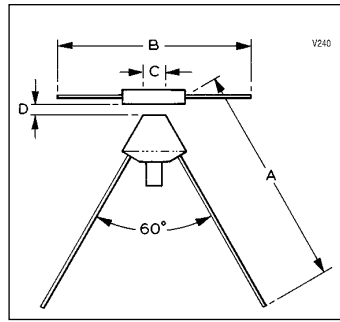

Fig 16.71: Key dimensions of discone antenna

of rods or tubes as illustrated in Fig 16.70. At least eight or preferably 16 rods are required for the 'disc' and 'cone' for reasonable results. Open mesh may be used as an alternative to sheet metal or rods.

The important dimensions are the end diameter of the cone and the spacing of this from the centre of the disc. These are instrumental in obtaining the best termination impedance, ie 50 ohms [32].

Fig 16.71 shows the key dimensions, which must satisfy the following requirements:

- A The length of the cone elements are  $\lambda/4$  at the lowest operating frequency ( $2952/f$  MHz inches).
- B The overall disc diameter should be 70% of  $\lambda/4$ .
- C The diameter of the top of the cone is mainly decided by the diameter of the coaxial feeder cable. For most purposes 0.5in will be suitable.
- D Spacing between top disc and the cone top is 20% of C or 0.1in for 50 ohms.

The detail given in Fig 16.72 of the 'hub' construction will be suitable for any design using a 50-ohm feeder cable and may be taken as an example. A suitable insulator can be made with a potting resin or turned from nylon, PTFE or other stable low loss material.

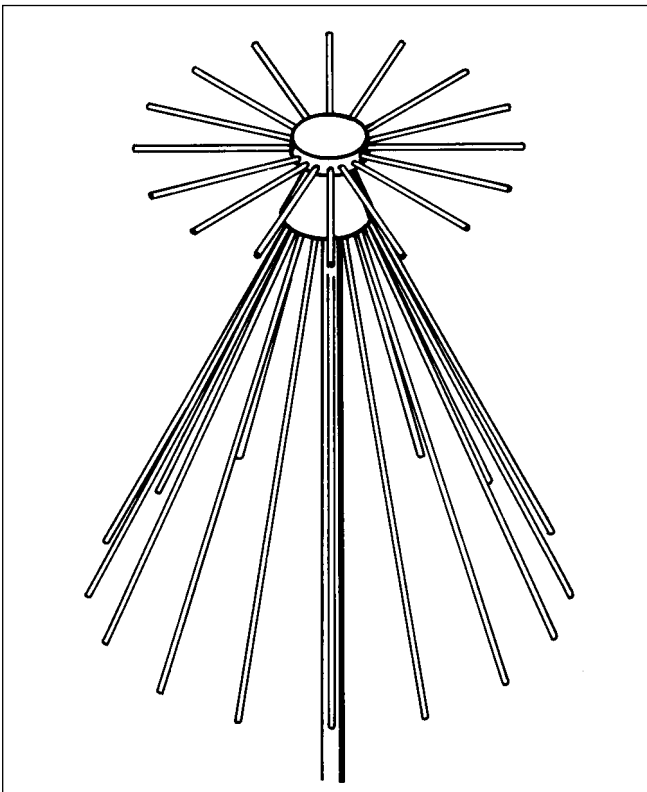

Fig 16.70: General arrangement of skeleton form of discone

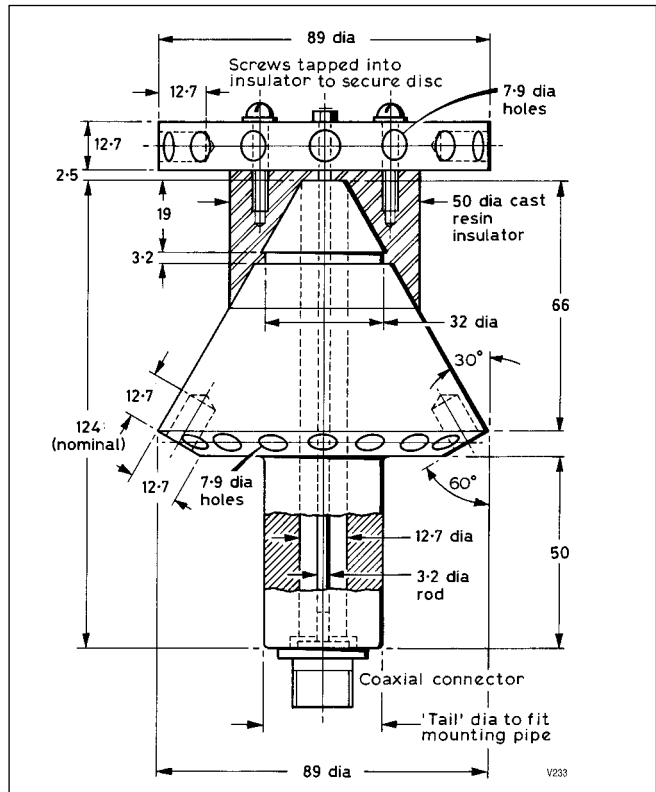

Fig 16.72: Details of discone hub assembly

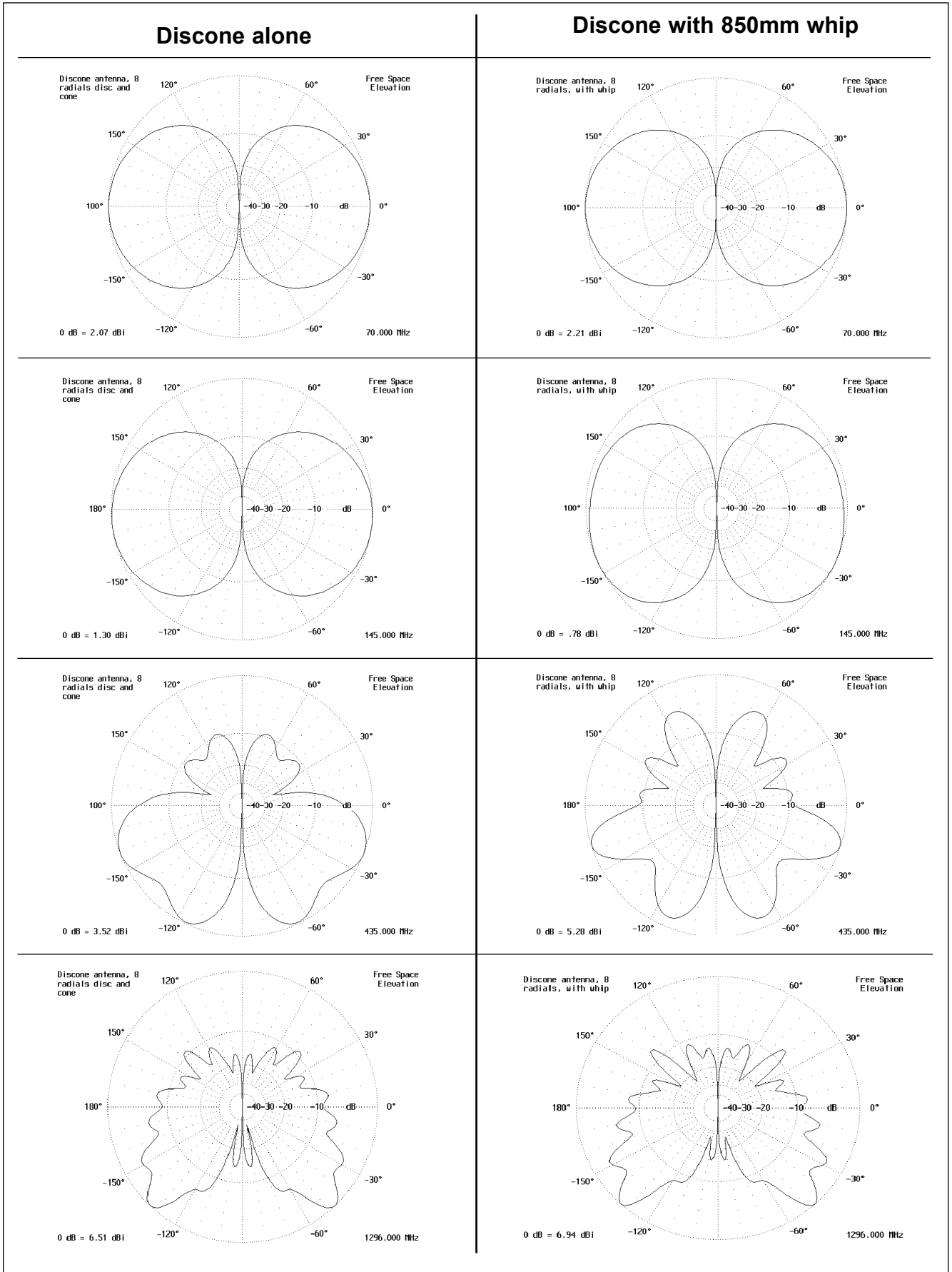
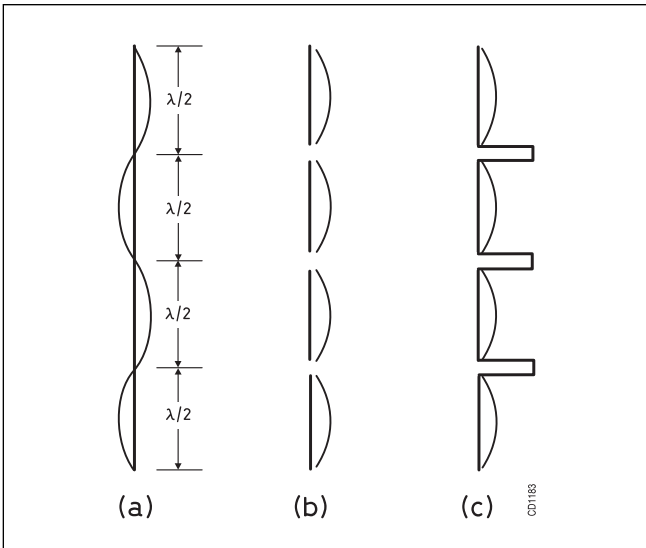

Fig 16.73: Discone elevation radiation patterns, with and without whip for low-frequency operation. Top radials are 305mm, skirt radials 915mm and whip 850mm in length. The whip length was not optimised for 70MHz.



**Fig 16.74: Current distribution on a wire, and derivation of the collinear antenna**

The low frequency coverage can be extended by fitting a whip antenna to the centre of the disk. The antenna then operates like a quarter wave whip on a skeleton groundplane (the cone providing the groundplane). The VSWR can be optimised at a particular frequency below disccone cut-off by adjusting the length of the whip, or several whips can be fitted, resonating at different frequencies, in the style of multi-band dipoles. This can be useful if the antenna is used for other purposes in addition to amateur band coverage. Fig 16.73 shows the calculated elevation radiation patterns for a conventional disccone at 145, 435 and 1296MHz, together with those of a disccone of the same dimensions fitted with a 850mm whip to provide 70MHz coverage.

**Collinear Dipole Arrays**

Communication with mobile stations is best achieved with a vertically polarised omnidirectional antenna, as there is no need to point the antenna in the direction of the mobile. However, a fixed station is not as constrained by mechanical considerations as a mobile, and can thus be fitted with longer, higher gain antennas.

This can be achieved by stacking dipoles vertically above one another in a collinear array, and feeding them with cables of equal lengths, as shown for the GB2ER repeater antenna later in this chapter. Another method of achieving gain with simpler feed arrangements is discussed below.

The current on a length of wire several wavelengths long will be distributed as shown in Fig 16.74(a). The wire shown is  $2\lambda$  long. Radiation at right angles to the wire will be poor, as the successive half wavelength current maxima are in opposite phases, and if the currents were equal, there would be perfect cancellation of the radiation from the oppositely phased pairs of current maxima. However, if all the current maxima were in phase, the radiated fields would add, and a high gain could be achieved. Fig 16.74(b).

There are several ways of achieving this phase reversal. The simplest is to insert an anti-resonant network or a non-radiating half-wavelength of transmission line as a phasing section between the half-wave radiating elements, Fig 16.74(c). The half wavelength transmission line can be realised as a quarter wavelength of ribbon cable, which can be wound around the insulator between the radiating elements (see the section on mobile antennas).

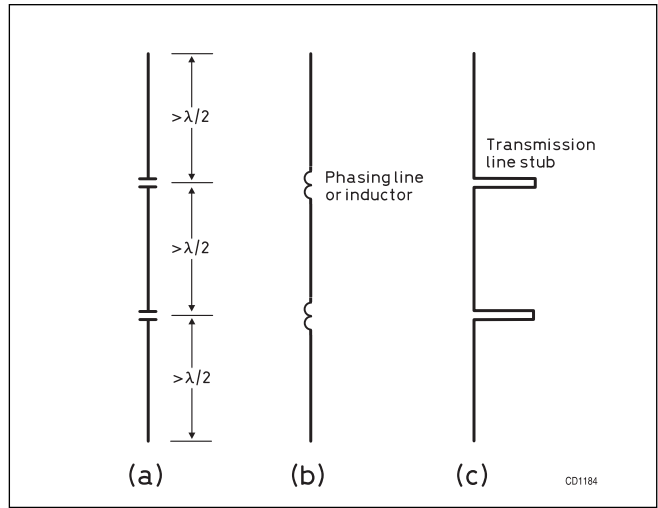

**Fig 16.75: Realisation of collinear antennas**

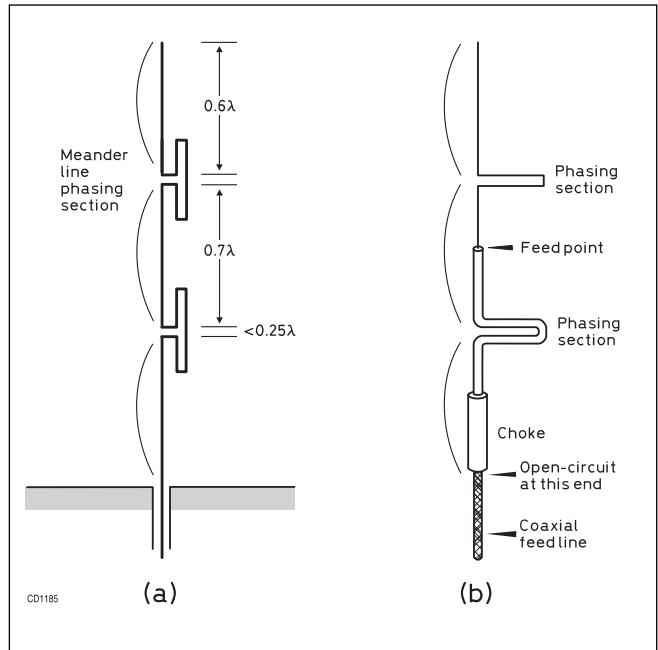

**Fig 16.76: Franklin collinear antennas, end-fed and centre fed**

A more subtle approach uses radiating elements that are a little longer or shorter than one half wavelength. This helps the feeding arrangements, as end feeding a half wave dipole is difficult because of its very high impedance. The self reactance of the longer or shorter dipole is then used in the design of the phasing network between the elements to achieve the desired overall phase shift. The non-radiating transmission line can then often be replaced by a capacitor or an inductor in series with the residual element reactance, Figs 15.75(a) and (b). Again, a transmission line stub can be used to synthesise the required reactance, which may be more convenient or cheaper than a lumped component if significant RF power handling is required, Fig 16.75(c). Sometimes a parallel tuned circuit is realised as an inductor resonated by the self-capacitance of the insulator separating the radiating elements, and upon which it is wound.

A technique devised by Franklin that has been attractive to VHF antenna manufacturers folds parts of the radiating element to provide the phasing section as shown in Fig 16.76(a). Provided that the folded sections are significantly shorter than

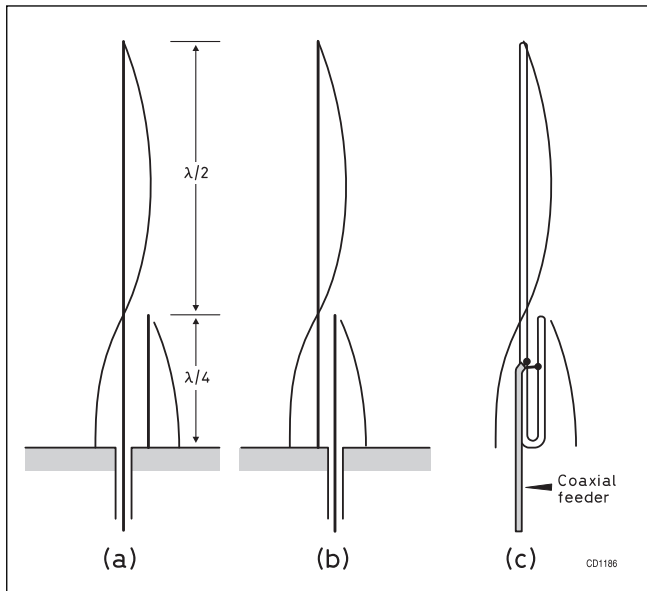

**Fig 16.77: The J antenna**

the radiating elements, the gain is not significantly degraded, although the whole structure is sensitive to capacitive loading by any housing and insulators required.

The radiation pattern is frequency sensitive, and the main lobe will squint upwards or downwards as the frequency changes from the nominal. Whilst these folded element designs look attractive for home construction, adjustments to optimise both the radiation pattern and input impedance are very difficult without proper measuring facilities. Poor gain and broken radiation patterns result if the sections are not properly excited and phased.

All these designs are end-fed, which have practical disadvantages for longer, multi-element arrays. If identical sections are used, the end elements carry less current than those close to the feed, reducing the overall efficiency of the antenna. Whilst different length radiators and phasing elements can be used to equalise the current distribution, the design and adjustment is lengthy, and definitely requires good radiation measurement facilities. If the array can be centre fed, any residual phasing errors tend to cancel out, and for a given length, the performance tends to be better because of a more uniform current distribution.

**Fig 16.76(b)** shows one means of achieving centre feeding with a Franklin array. Note the use of the quarter wave choke section at the base of the array, which is essential to prevent current flowing down the outer of the coaxial cable and destroying the performance of the antenna. The practical gain limit of the singly-fed collinear antenna is around 10dBi.

Practical collinear antennas in radio amateur use tend to use variations on Fig 16.75. The radiating elements may comprise combinations of lengths up to  $5/8\lambda$ , with or without ground planes. The presence of a good groundplane increases the gain as the image or reflection effectively doubles the length of the array (see also the section on mobile antennas). However, good results can be achieved with collinear antennas directly mounted on pipe masts, especially if care is taken to minimise unwanted currents flowing on the mast.

## The J Antenna

Collinear antennas, by virtue of their operation as end-fed structures, have high feed point impedances. A good feed arrangement, valid for both ground-plane and mast mounted antennas,

**Fig 16.78: The basic Slim Jim, showing direction of current flow and phase reversal (Practical Wireless)**

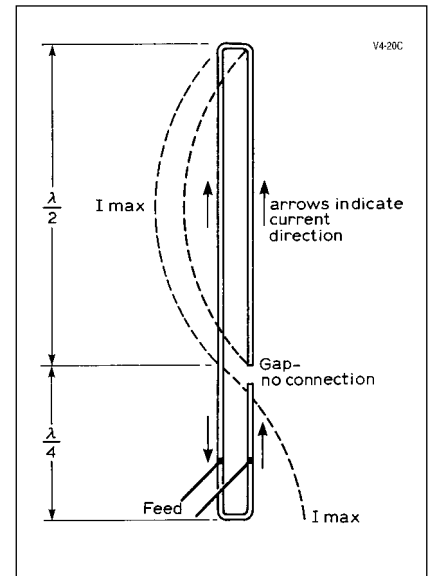

uses a quarter-wave short-circuited transmission line, as described in the chapter on antenna fundamentals.

**Fig 16.77** shows such an arrangement to end feed a half wave dipole mounted over a groundplane. The matching section should not radiate, and the overall effect is that of a half wave radiator raised  $\lambda/4$  above the groundplane. Either leg of the quarter wave section can be fed, leading to the structure in **Fig 16.77(b)**, which is identical to **Fig 16.77(a)** in terms of current distribution, and hence radiation performance. The evolution can be taken a stage further by removing the groundplane and feeding either leg of the quarter wave section as in **Fig 16.77(c)**; this is the 'J' or 'J-pole' antenna, which may use different diameters of tubing for the radiator and stub.

The 'Slim Jim' antenna provides an elegant solution for a simple, mechanically robust antenna made from a single piece of tubing as shown in **Fig 16.78**.

This antenna, described in [33] comprises a folded, open circuit  $1/2\lambda$  radiator above a  $1/4\lambda$  transformer section, and is a derivative of the 'J' antenna. The folded stub characteristics of the radiator provide some control over the reactive element of the input impedance.

The two ends of the tube can be joined by an insulator, eg a piece of stiff plastic tubing, to provide weather proofing and enhanced mechanical rigidity. Either balanced or unbalanced feeds can be used, tapped on to the  $1/4\lambda$  transformer section at the point that provides the best match to the feeder. Coaxial feeders should be strapped or bonded to the quarter wave section to reduce unwanted currents on the outer of the cable.

The antenna has a maximum gain of around 2.8dBi (0.6dBd) in free space, although the main lobe is tilted up about 10 degrees.

The main lobe can be brought to the horizontal by reducing the length of the upper section to about 0.4 wavelengths. This reduces the peak gain to around 2.5dBi (0.3dBd), and can make the feed impedance capacitive.

Phasing sections and additional elements can be combined to produce a collinear form for the 'J' as shown in **Fig 16.79(a)**. This antenna and that of **Fig 16.79(c)** have been used successfully to produce low-angle radiation for the GB3SN 144MHz repeater.

A variation of the techniques described, using coils as with the original Marconi concept, is shown in **Fig 16.80(a)** for 432MHz and **Fig 16.80(b)** for 144MHz. The expected gain is between 6 and 7dBd.

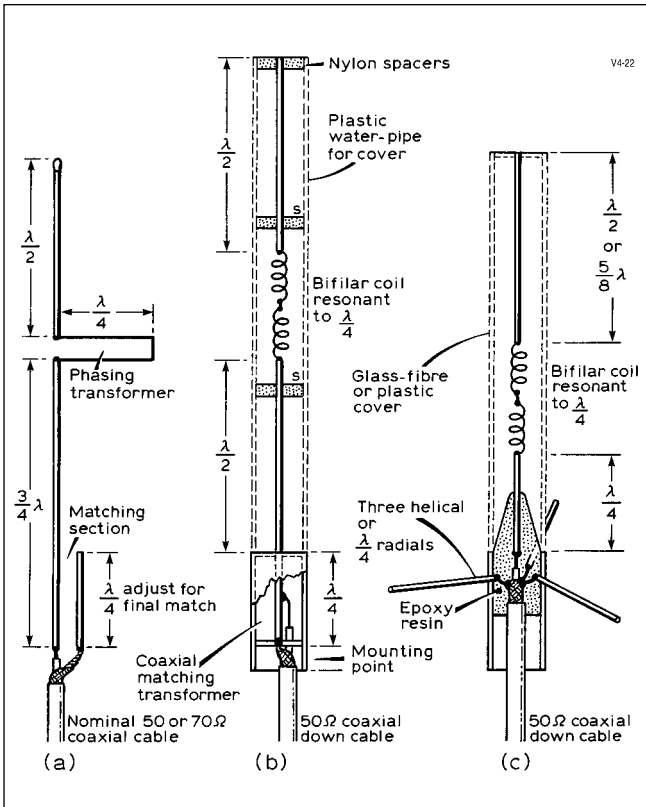

**Fig 16.79: A collinear form of 'J' antenna: (a) the addition of  $\lambda/4$  sections as suggested by Franklin; (b) Use of a coaxial short-circuit  $\lambda/4$  transformer to give an unbalanced input. The tapping point of the matching transformer is approximately  $0.15\lambda$  from the 'earthy' end; (c) A variant of (b) with radials, With both (b) and (c) the  $\lambda/4$  phasing transformer has been 'wound up' as a bifilar coil (each coil being wound in the opposite hand). While the inductive component is cancelled, the mutual capacitance of the windings makes them physically shorter than a quarter wavelength**

Materials required for Fig 16.80(a) are as follows:

- One 2.5cm diameter 10cm long glassfibre tube.
- One 4.0mm diameter 1.2m long glassfibre rod.
- Four 2.0mm diameter 20cm long glassfibre rods.
- Length of braiding from 'junk' large coaxial or multicore cable.
- Length of 1.2mm wire for matching coils.
- Approximately 5cm square of singled sided PCB.

First, adjust the bottom  $5/8\lambda$  element to give minimum VSWR by moving the tapping point on the bottom coil (approximately four turns). A fine adjustment can be made by altering the length of the first  $5/8\lambda$  element.

Next fit the centre matching coil and the top element. To obtain the best results, both elements should be the same length and approximately  $5/8\lambda$ . Further improvement in VSWR is obtained by adjusting the centre matching coil (the coil is spread over  $1/4\lambda$ ).

The matching coil provides the phase change necessary to feed the top element and so adjustment is quite critical. If the matching coil has to be 'squeezed up' to obtain a good VSWR, the coil has too many turns.

The opposite is true if the coil has to be greater than  $1/2\lambda$  for a good VSWR.

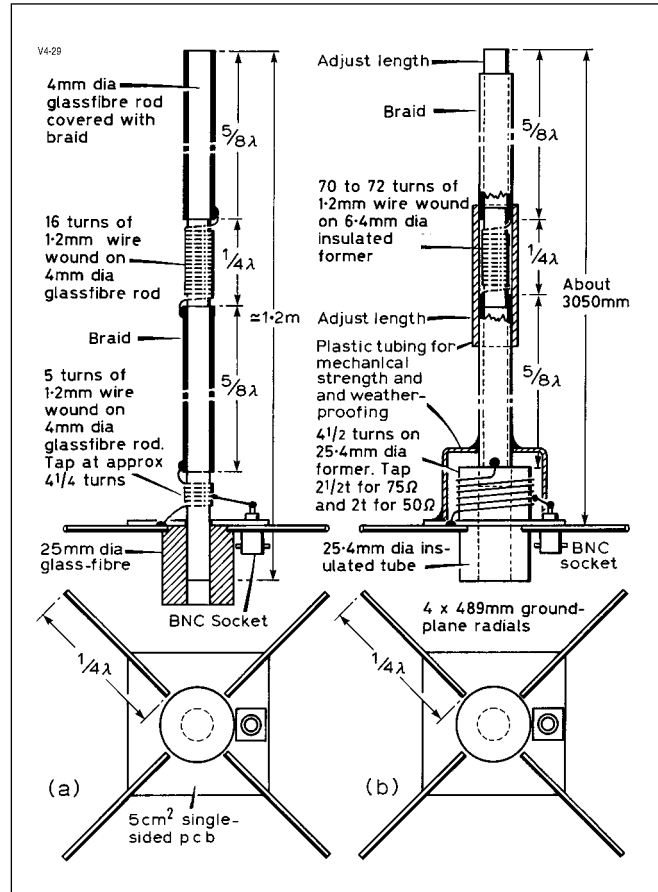

**Fig 16.80: (a) A 432MHz collinear antenna (b) A 144MHz collinear antenna (UK Southern FM Journal)**

To prevent the collinear going 'off tune' once set up, the elements are secured to the centre glassfibre rod and the matching coil taped with self amalgamating tape. Provided care is taken in setting up, a VSWR close to 1.1:1 can be obtained.

Materials required for Fig 16.80(b) are as follows:

- Two 12.7mm diameter by  $1206 \pm 12\text{mm}$ ,  $5/8\lambda$  elements (adjustable).
- Four 495mm rods for the ground plane.
- One 6.4mm diameter by 762mm insulated rod.
- One 25mm diameter insulated tube (a cotton reel can be used).
- 1.6mm wire for matching and phasing coils.

The diagram shows extra insulated tubing over the matching and phasing coils to give more mechanical strength and weather-proofing.

Setting up is carried out as follows. First, adjust the length of the bottom  $5/8$  element to give minimum VSWR.

Secondly, fit the phasing coil and the top element. The top element must be the same length as the set-up, bottom element. Next obtain the best VSWR by 'adjusting' the turns of the phasing coil.

The coil provides the phase change necessary to 'feed' the top element. It consists of a length of 1.6mm wire, (about  $1\lambda$ ), coiled up to give 70-72 turns on a 6.4mm diameter former. The  $\lambda/4$  spacing between the two elements is more critical than the number of turns. 68 turns gave a satisfactory VSWR with the prototype.



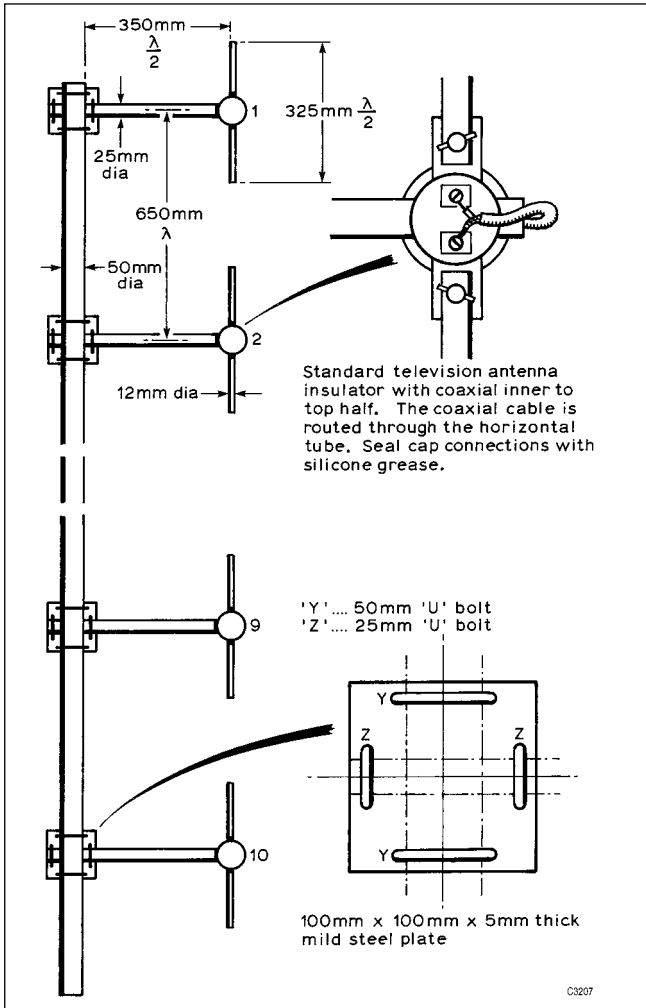

Fig 16.81: Mechanical details of GB3ER collinear

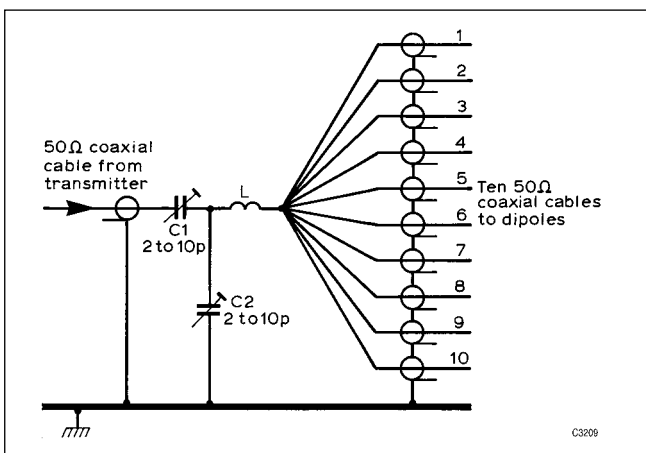

Fig 16.82: Matching Unit of GB3ER collinear

Some difficulty may occur in setting up the phasing coil. If more than seven turns have to be removed, go back to the first adjustment stage to ensure the bottom  $5/8\lambda$  element is correctly matched. If the bottom element is not correctly set up the collinear will not tune up.

Careful adjustment should produce a VSWR of 1.1:1 at the chosen operating frequency.

A technique, widely used for commercial systems, combines  $\lambda/2$  dipoles fed in phase from a single source, or alternatively

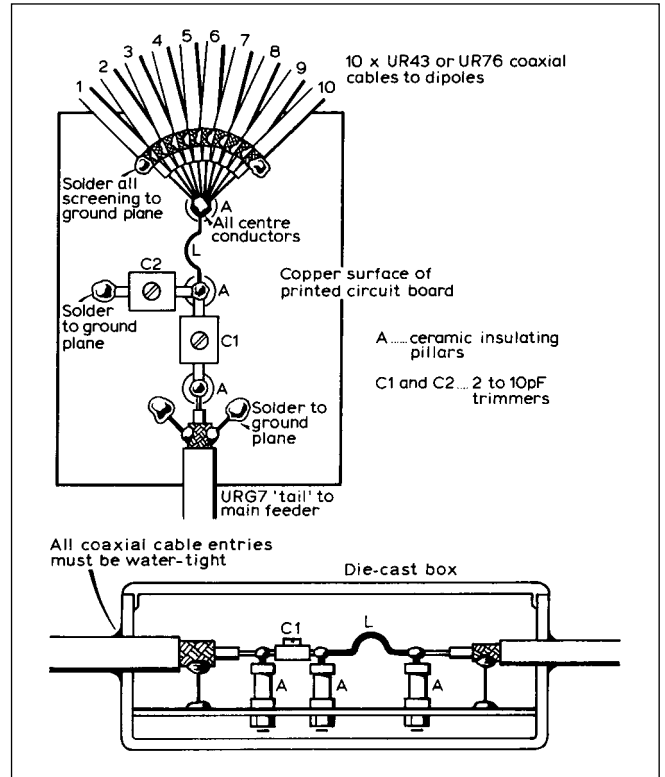

Fig 16.83: Matching unit layout for GB3ER collinear

with an appropriate variation of feeder cable length between dipoles to provide phasing.

The disadvantage with this form of antenna array is that some interaction occurs between cables and radiating elements. However, the disadvantage is balanced by the ability to modify the radiation pattern shape by simple adjustment of dipole spacing or phasing cable length.

The example given in Figs 16.81, 16.82 and 16.83 is probably the simplest to set up and was devised for the GB3ER 432MHz band repeater. If the cables are made to be an odd number of quarter wavelengths long, an equal current feed to each dipole is assured.

### 70cm Repeater Antenna

A four element 70cm D-Star repeater antenna made from copper water pipe and plumber's fittings with excellent VSWR at 432 and 438MHz is shown in Figs 16.84 and 16.85. Each element comprises a folded dipole fed by coaxial cable run through the tubing and a tee piece at the electrically neutral point on the tube opposite the feed point.

The short piece of tubing attached to the tee piece is used to clamp the dipole to its support mast. A four-way power divider made from standard coaxial cable, N type connectors and tee pieces feeds the dipoles in phase and transforms their combined impedance to 50 ohms. This antenna requires care in construction and adjustment with access to impedance

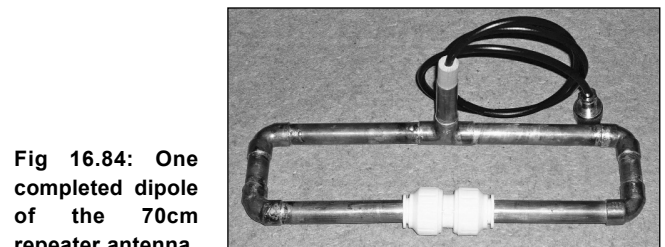
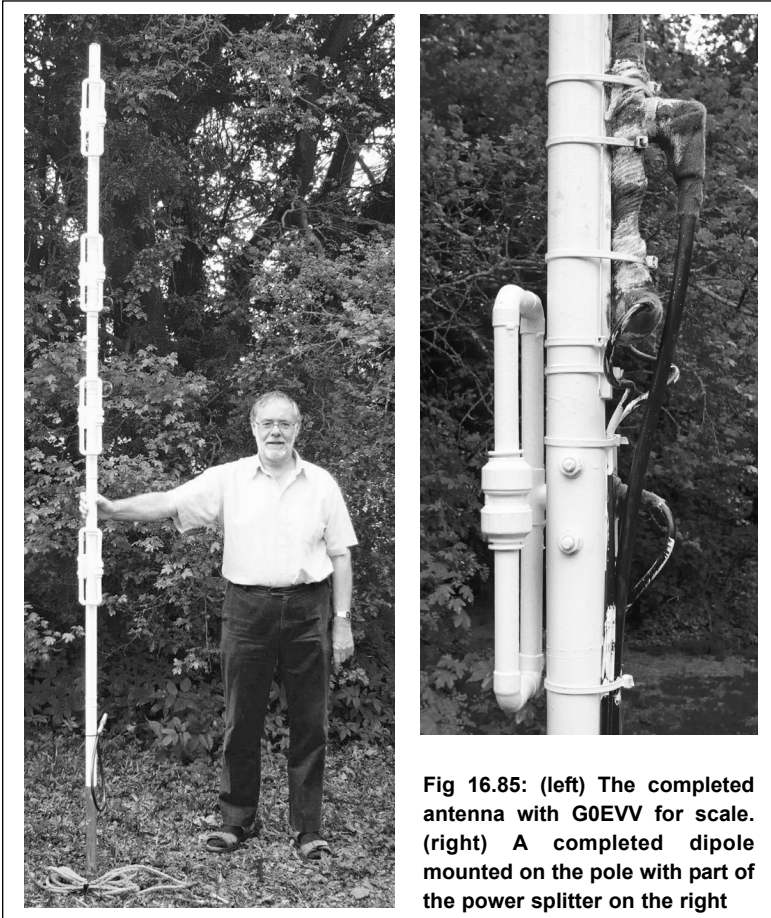
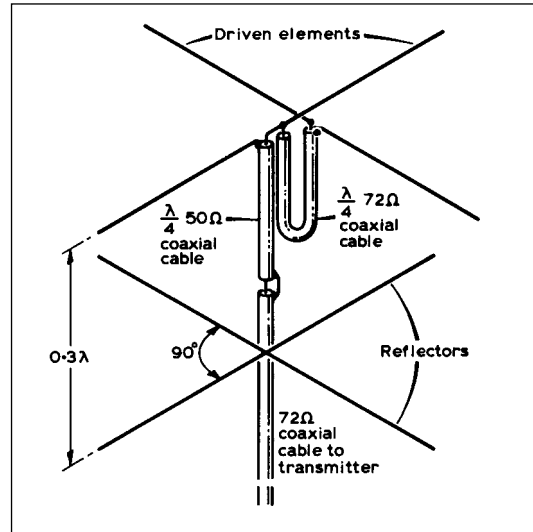

Fig 16.84: One completed dipole of the 70cm repeater antenna



**Fig 16.85: (left) The completed antenna with G0EVV for scale. (right) A completed dipole mounted on the pole with part of the power splitter on the right**



**Fig 16.86: A crossed dipole antenna for 145MHz**

### Crossed Dipole or Turnstile Antenna

Fig 16.86 shows a simple arrangement of crossed dipoles above a ground plane for 145MHz. This type of antenna can be scaled for use at 29, 145 or 432MHz. Mechanical problems may make the reflectors inadvisable in a 29MHz version. The height above ground can be about 2m for 145MHz and 3m for 29MHz.

Typical dimensions are:

29MHz	driven elements ( $\lambda/2$ )	188in	4775mm
145MHz	driven elements ( $\lambda/2$ )	38in	965mm
	reflectors	40.5in	1030mm
	spacing ( $0.3\lambda$ )	24.5in	622mm

measuring equipment to make it perform well. A list of materials and details for construction are given in [34].

## ANTENNAS FOR SATELLITE COMMUNICATION

For the radio amateur, satellite ground station antennas fall into two groups. The first group comprises *steerable antennas*, which enable the passage of the satellite to be tracked across the sky. The second group consists of *fixed antennas*, which have essentially hemispherical radiation patterns to receive the satellite signals equally from any direction. These antennas do not need to be steered to receive signals during the satellite's passage.

The tracking antennas are usually of high gain, while the fixed antennas are usually of low gain, due to their hemispherical coverage. Fortunately, signal losses between ground and the satellite in line-of-sight are relatively low. With no obstructions, low-gain antennas of the fixed variety are often acceptable for reception of amateur or weather satellites, helped by the higher radiated powers available from current low-earth orbiting amateur satellites.

As many satellites rotate or change their orientation with respect to the ground station, both groups of antennas are designed to provide circular polarisation. Amateur convention calls for the use of Right-Hand circular polarisation for earth/space communications. However, the downlink may have either Left or Right handed polarisation according to the satellite and frequency in use. Of the higher-gain tracking antennas, the crossed Yagi and the helix antenna are the main ones used. The crossed Yagi is probably the easiest to construct and most readily available commercially. Construction details for these antennas were described earlier, and polarisation switching schemes are discussed at the end of this chapter.

The phasing line comprises  $\lambda/4$  of 72-ohm coaxial cable. The matching section for a 72-ohm feed is  $\lambda/4$  of 50-ohm cable. When calculating the length of the  $\lambda/4$  sections, the velocity factor of the cable must be taken into account. Typically this is 0.8 for cellular and semi-airspaced cables, and 0.66 for solid dielectric cables, but verification of the figure for the particular cable used should be obtained. As an example, a matching section of RG59/U would be 13in (330mm) in length. Omit the transformer section for 50-ohm operation. This will result in an input VSWR of less than 1.4:1. For a centre-fed crossed dipole, it is advisable to have a 1:1 balun to ensure a consistent pattern through 360° of azimuth. Dependent on the spacing between the dipoles and ground plane, the radiation pattern can be directed predominantly to the side, for satellites low on the horizon, or upwards for overhead passes.

By drooping the dipole elements at 45°, with a spacing of approximately  $0.4\lambda$  between the dipole mounting boss and the ground plane/reflectors, better coverage towards the horizon can be obtained. As ground reflections affect horizontal and vertical polarisation differently, low-to-horizon flight paths will not produce circular polarisation. This is due to 'ground scatter' of the satellite signal when it is low on the horizon, and ground reflections locally at the ground-based antenna. Circular polarisation is normally produced by feeding one dipole 90° out of phase to the second dipole, and can be achieved by having an extra  $\lambda/4$  of cable on one side of a combining harness.

An alternate approach to this method of phasing is to use the phasing properties of a capacitive or inductive reactance.

Suppose, for example, that the length and diameter of the dipoles are set to give a terminal impedance of  $70\Omega - j70\Omega$  (capacitive). If a second, crossed dipole is set to be  $70\Omega + j70\Omega$  (inductive) the combined terminal impedance of the arrangement becomes  $35\Omega \pm j0$ , ie 35 ohms resistive.

As the two dipoles are connected in parallel, the current in each dipole is equal in magnitude. However, due to the opposite phase differences of  $45^\circ$  produced by the capacitive and inductive reactances, the radiated fields are in phase quadrature (a  $90^\circ$  phase difference) which results in circularly polarised radiation.

### Hairpin or Sloping Antennas

As technology has advanced, so has the radiated power from low earth orbiting amateur radio satellites increased, to the extent that communications can be established using handheld radios if the satellite is well above the horizon. Accordingly, it can be worth constructing very simple antennas to get started with satellites.

A vertical whip on a ground plane produces a null along the axis of the whip. However, if the whip is bent over by about  $30^\circ$ , the overhead null is filled without degrading the azimuth pattern

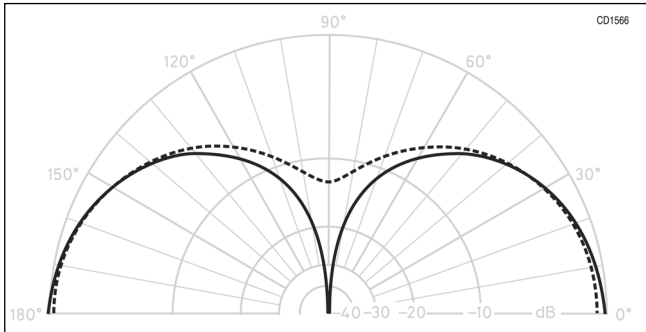

**Fig 16.87:** Elevation radiation pattern for a whip antenna sloping 30 degrees on a large groundplane. The pattern for a vertical whip is also shown for comparison.

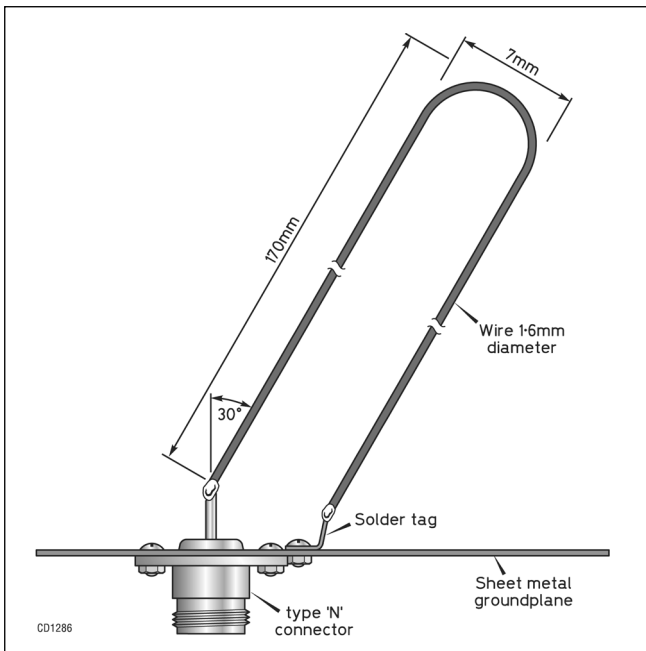

**Fig 16.88:** Construction of 435MHz hairpin antenna and groundplane

too severely (**Fig 16.87**). For 145MHz operation, the whip should be around 480mm in length, and adjusted for best match according to the size of the groundplane.

At 435MHz, a *hairpin* construction from 1.6mm diameter wire (or even a wire coat hanger) is somewhat more rugged, and can offer wider bandwidths because of the transforming action of the folded dipole. The connector/feed point joint should be potted or sealed with silicon rubber or flexible epoxy resin if the antenna is to be used outdoors, to prevent moisture entering the cable (**Fig 16.88**). The antenna can be tuned, without seriously degrading the radiation pattern, by adjusting the spacing between the wires or by changing the slope of the hairpin a few degrees, or a combination of both.

### Eggbeater Antennas

This omnidirectional antenna produces excellent circularly polarised signals over a wide range of elevation angles if carefully constructed. It comprises a pair of crossed circular loops, slightly over one wavelength in circumference, and fed in phase quadrature. The only disadvantage is the high terminal impedance of each loop (approximately 140 ohms, which requires a transformer section to match to 50 ohms [35].

Performance has been further optimised for satellite operation by K5OE by using square loops and adding tuned reflectors as a groundplane [36]. This antenna can be built with an excellent match to 50 ohms without recourse to special impedance cables.

The general arrangement is shown in **Fig 16.89**. The loops are constructed of rod, tubing, or 2mm enamelled copper wire for 70cm, bolted to a 22mm plastic water pipe coupler. Critical

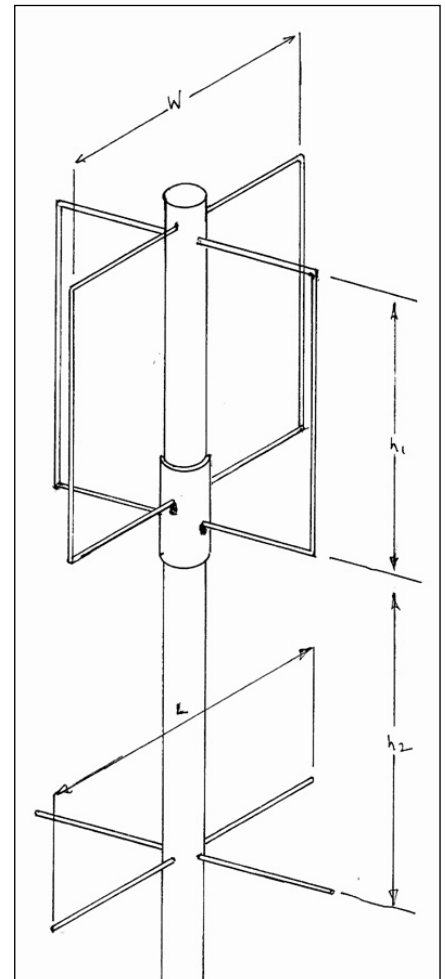

**Fig 16.89:** General construction arrangements for K5OE Eggbeater II antenna

Design frequency	w	h1	L	h2	Loop wire dia	Phasing cable length
137MHz	540	665	1065	1080	5	390
145.5MHz	510	625	1000	1010	5	370
435MHz	170	210	335	330	2	124

**Table 16.16:** K5OE Eggbeater antenna critical dimensions in mm. Phasing cable lengths are for solid PTFE dielectric, and should be measured between where the inner dielectric clears the braided coaxial outer

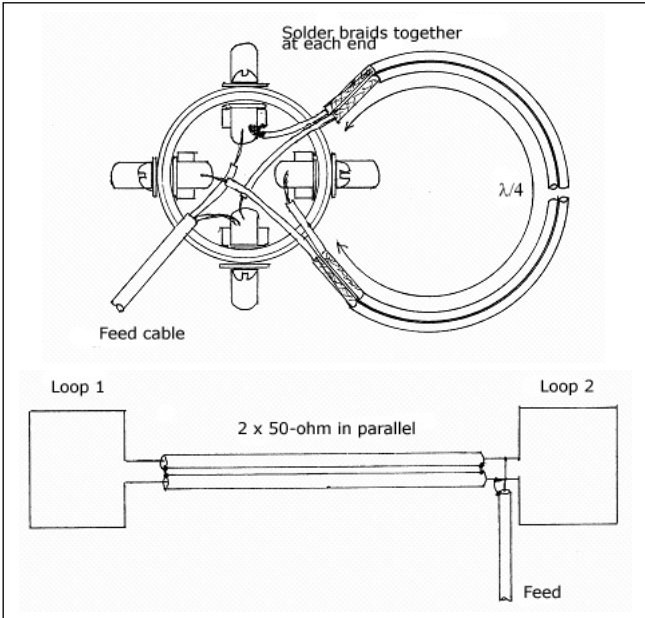

**Fig 16.90:** Feed point construction detail and phasing line connections for Eggbeater antenna

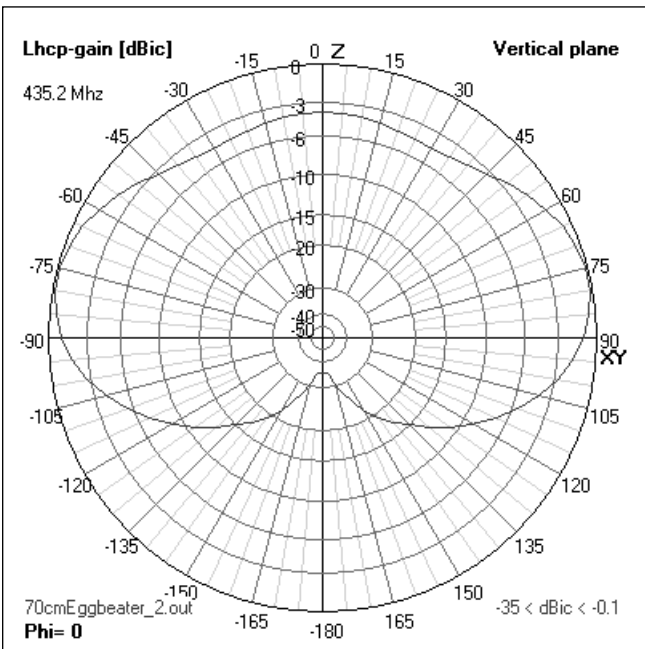

**Fig 16.91:** Elevation radiation pattern for 70cm Eggbeater antenna. The azimuth pattern is essentially omnidirectional. Note the gain figures are in dBi

**Fig 16.92:** K5OE Eggbeater II without weatherproofing



dimensions are shown in **Table 16.16**. The tops of the loops are supported by a section of (plastic) water pipe that fits into the coupler, and capped to prevent water ingress. One loop should be set 5 - 10mm higher than the other so that the top of the loops can cross without touching. Instead of the 93-ohm RG62 cable described by K5OE, the phasing section can be made from two pieces of 50-ohm cable, each one quarter-wavelength long, with the outers connected together at each end. This makes a 100-ohm balanced wire transmission line, which can be coiled or folded up if required.

All four braids can be connected together if the connections are conveniently close together (e.g. the 70cm variant). The antenna is Left Hand Circularly Polarised (LHCP) if the connections are as shown in **Fig 16.90** when the antenna is viewed from below. To change the polarisation to RHCP, transpose the two phasing cable connections at one end only.

For many purposes, a 50-ohm coaxial feeder can be connected directly as shown. Five or six turns of feeder closely wound can provide a balun and choke against current on the outside of the cable if required.

A ferrite bead fitted on the feed cable close to the connection can be effective, and there is space for a low noise amplifier inside the water pipe between the coupler and the tuned reflectors if the antenna is to be used only for reception.

Calculated radiation patterns for the 435MHz variant are shown at **Fig 16.91**. **Fig 16.92** shows the antenna construction.

### Quadrifilar Helix or Volute Antenna

The quadrifilar helix (QFH) or volute is a four-element helical antenna which can be used to give either directional gain or hemispherical circular polarised coverage as originally described by Kilgus [37] [38]. The general form of a QFH is shown in **Fig 16.93**.

Radiation patterns produced for several combinations of turns and resonant lengths are shown in **Fig 16.94(a) to (d)**, and generally produce better circularly polarised signals at low elevation angles than a turnstile with drooping arms.

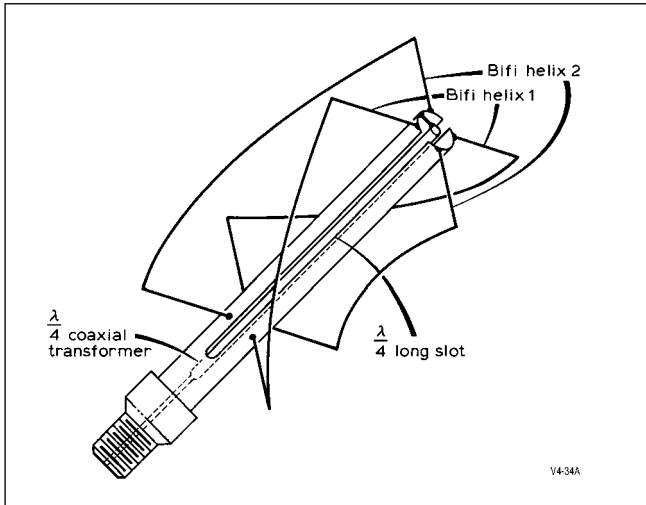

**Fig 16.93: A quarter turn volute with split sheath or slot balun (Microwave Journal)**

The QFH can make use of a phasing line or the reactance method (as previously discussed for the turnstile antenna) to produce circular polarisation. The number of 'turns' or part turns of the radiating elements combined with their length can be used to produce various radiation patterns. Elements that are multiples of  $\lambda/4$  have open-circuit ends, while the elements that are multiples of  $\lambda/2$  can be short-circuited to the mounting structure.

Good radiation patterns for communication with low earth orbiting satellites (LEOs) can be produced by QFHs with diameters less than  $0.1\lambda$  and one quarter turn per loop. This makes antennas for 145MHz possible without large support structures or incurring high wind load penalties [39] [40].

Constructional details must be followed exactly if impedance measuring test equipment is not available to adjust the element lengths.

The radiation pattern of a quarter turn QFH antenna is shown in Fig 16.95.

'Long' QFH with multiple turns can produce even better low angle coverage, but are generally only suitable for 435MHz or above because of their length.

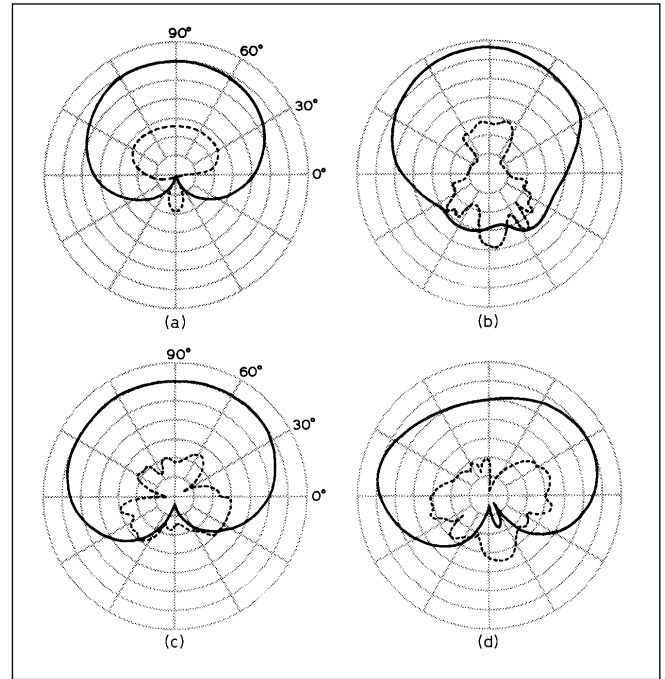

**Fig 16.94: Volute radiation patterns, co- and cross-circular polarisation (a) 3/4 turn  $\lambda/4$  volute. (b) 3/4 turn  $\lambda/2$  volute. (c) 3/4 turn  $3/4\lambda$  volute. 3/4 turn  $1\lambda$  volute (Microwave Journal)**

**CONTROL OF ANTENNA POLARISATION**

Vertical polarisation is the most popular for FM and mobile operation in the UK. This means that a fixed station with antennas optimised for horizontal polarisation can only operate effectively if two antennas or a means of changing polarisation is available.

Space communication, where control of polarisation at the spacecraft end of the link can be difficult, has stimulated the use of circular polarisation. Its fundamental advantage is that, since reflections change the direction of polarisation, there can be far less fading and 'flutter' from reflections.

The use of circular polarisation at only one end of the link, with horizontal or vertical linear polarisation at the other end of the

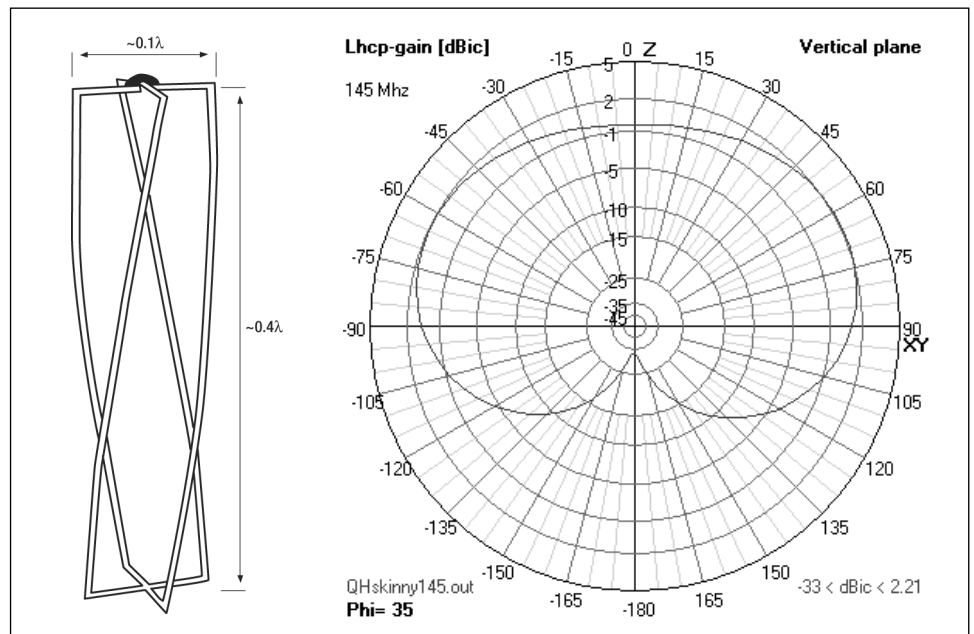

**Fig 16.95: Quarter turn slim quadrifilar helix antenna and elevation radiation pattern. Each loop is approximately  $1\lambda$  in circumference. Support pole not shown**

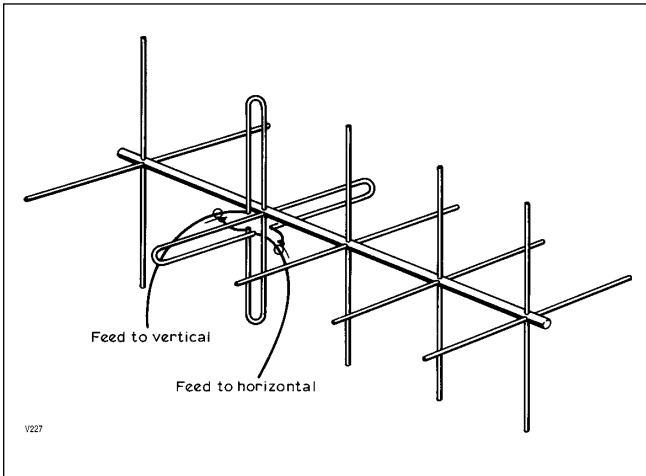

**Fig 16.96: General arrangement of a crossed Yagi antenna**

link, will result in a loss of 3dB. However, changes of polarisation caused by propagation often result in better reception of linearly polarised signals with a circularly polarised antenna. Conversely, if circular polarisation is used at both ends of the link, but the two stations use oppositely polarised antennas, the loss of signal due to polarisation mismatch can be 10dB or more.

It has been usual to standardise on Right-Hand Circular polarisation (RHCP) in the northern hemisphere for fixed communications. Space communications may use either Right or Left Hand Circular polarisation according to the frequency used and the satellite of interest.

The helix antenna produces Right or Left-Handed circular polarisation dependent upon whether the antenna element is wound clockwise or anti clockwise. Horizontal or vertical linear polarisation is also possible from helix antennas by using two helices and suitable phasing arrangements.

A compromise arrangement for receiving circular-polarisation signals is to use slant polarisation. To obtain this, a single Yagi is set at an angle of 45°. This enables horizontal and vertical signals to be received almost equally. At first sight one would expect a loss of 3dB for H and V polarised signals compared with an appropriately aligned Yagi. However, long-term practical measurements have shown when averaged that this arrangement gives a 6dB improvement with typical mixed polarised signals. In addition this arrangement it is only a little affected by the mounting mast, unlike a vertical polarised Yagi.

The simplest way of being able to select polarisation is to mount a horizontal Yagi and a vertical Yagi on the same boom, giving the well-known *crossed Yagi* antenna configuration (Fig 16.96). Separate feeds to each section of the Yagi brought down to the operating position enable the user to switch to either horizontal or vertical.

It is perhaps not generally realised that it is quite simple to alter the phasing of the two Yagis in the shack and obtain six polarisation options. These are two slant positions (45° and 135°), two circular positions (clockwise and anti-clockwise) and the original horizontal and vertical polarisation.

The presence of the mast in the same plane as the vertical elements on a Yagi considerably detracts from performance, but a simple solution is to mount the antennas at 45° relative to the vertical mast. With appropriate phasing, vertical and horizontal polarised radiation patterns can be obtained that are unchanged by the presence of the mast.

If a crossed Yagi is mounted at 45°, with individual feeders to the operating position, the polarisation available and the phasing required is as follows:

- (a) Slant position 45° and 135°. Antennas fed individually.
- (b) Circular positions clockwise and anti-clockwise. Both antennas fed 90°+ or 90°- phase relationship respectively.
- (c) Horizontal and vertical polarisation. Both antennas fed with 0° or 180° phase relationship respectively.

Phasing is simply the alteration of the length of the feeders of each crossed Yagi to change the polarisation. Where a 90° phase shift is required,  $\lambda/4$  of cable is inserted and, where a 180° phase shift is required,  $\lambda/2$  cable is inserted. The polarisation switch must switch in the appropriate  $\lambda/4$  'impedance transformer' and correct phasing by connecting the appropriate length(s) of cable.

### Mast-head Multiple Polarisation Switch for 145MHz

There are several disadvantages in locating the polarisation switch in the shack. Two feeders are required from the antenna to the equipment, and RF losses may be significant if the antennas are positioned on a mast. Whilst it is technically feasible to improve signal to noise performance by installing twin preamplifiers at the antennas, the problems of equalising gain and ensuring relative phase stability are formidable. An alternative solution is to place the polarisation switch close to the antennas, which minimises the feeder losses, and to utilise a single preamplifier (with transmitter bypass arrangements if required) immediately after the switch to improve the system signal to noise ratio before despatching the signals to the receiver via a single feeder.

The polarisation switching circuit (Fig 16.97) offers a fair compromise between cost, complexity and performance. A pair of half crystal-can double pole changeover relays (Table 16.17) insert extra lengths of line into the feeds of a 50-ohm crossed Yagi antenna mounted at 45 degrees to its support mast, to provide four

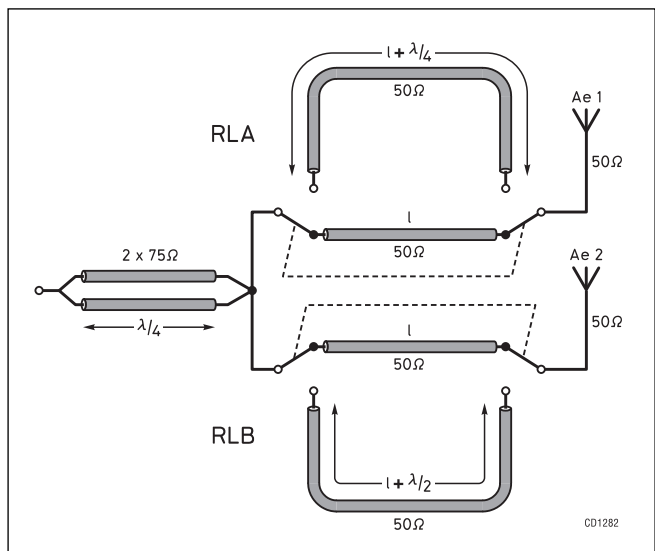

**Fig 16.97: Masthead antenna polarisation switch**

Characteristic	145MHz	435MHz
Insertion loss	<0.2dB	<0.3dB
Mismatch	<1.03:1	<1.2:1
Isolation between normally open and moving contact	42dB	30dB
Isolation between moving contacts	39dB	28dB

**Table 16.17: Half crystal can relay measured characteristics**

polarisations (Fig 16.98). The antenna cable lengths must be cut to compensate for any phase differences between the antennas due to physical offset in the direction of propagation. Under ideal conditions with perfectly matched antennas, the four main polarisations will be achieved. If the antennas are not well matched to 50 ohms, the power division will not be equal, and mixed polarisation will result for each relay setting. If the VSWR is less than 1.2:1, the depolarisation will not be serious.

The relays are mounted on 1.6mm double sided copper clad glass fibre PCB with 50-ohm microstrip tracks for the RF circuits (Fig 16.99). RF interconnection and phasing lines are made from 3mm PTFE cable (URM 111 and T3264) which provides a good trade-off between losses and size for coiling up within a diecast weatherproof box. Polythene dielectric cables could possibly be used if soldered very quickly, but this is not recommended. The cable ends must be kept as short as possible as shown in Fig 16.99. The polarisation unit will handle 100 watts of CW or FM, provided that the antenna system VSWR at the relay is better than about 1.5:1. Miniature PTFE cables in small quantities can be obtained from [41].

If a transient suppression diode is to be fitted across the relay coil, it should be bypassed with a 1nF capacitor, or rectified RF pickup during transmission may cause the relay to change state. Experience has shown that it is better to dispense with the diode at the relay altogether if high transmitter powers are involved.

### Circular Polarisation Feed and Reversing Switch

The following simple arrangement generates remotely selectable Right or Left hand circular polarisation from a crossed Yagi antenna, or two separate, identical Yagi antennas with their elements set at right angles to each other. It will work well provided that both antennas are closely matched to 50 ohms, and it uses readily obtainable cables, adaptors and connectors throughout (Fig 16.100). It should be mounted close to the antenna(s).

The electrical length of the two antenna cables must be an odd number of quarter wavelengths.  $\lambda/4$  should be sufficiently long to make the connections for 2m operation, and  $3\lambda/4$  for 70cm. Higher multiples of  $\lambda/4$  will reduce the VSWR and polarisation bandwidths of the antenna. If longer antenna cables are necessary, equal lengths of 50-ohm cable should be used to connect the antennas to the  $\lambda/4$  75-ohm sections at the relay.

The 50-ohm impedance of the antenna is transformed by the quarter wave sections to 100 ohms at the T-piece. A quarter wavelength of RG62 (93-ohm) cable provides the phasing needed to produce circular polarisation, and the common relay contact, in either position, 'sees' two 100-ohm loads in parallel, ie 50 ohms, for presentation to the download.

Suitably weatherproofed PL239-series connectors will work for 2m operation, but type N connectors should be used for 70cm. The electrical length of the connectors and tee-pieces must be taken into account when cutting the quarter wavelength cables.

For 1.3GHz and above, use separate circularly polarised antennas and a change-over relay if selectable polarisations are required.

### REFERENCES

- [1] www.vhfman.freeuk.com/radio/antennas.html. General construction notes and sources of materials (UK)
- [2] 'Notes on the Development of Yagi arrays', C Greenblum, QST and other ARRL publications, edited by Ed Tilton, W1HDQ
- [3] 'Yagi-Uda Arrays', Chen and Cheng, *Proc IEEE*, 1975
- [4] 'Yagi Antenna Design', P Viezbicke, *National Bureau of Standards Technical Note 688*, 1976

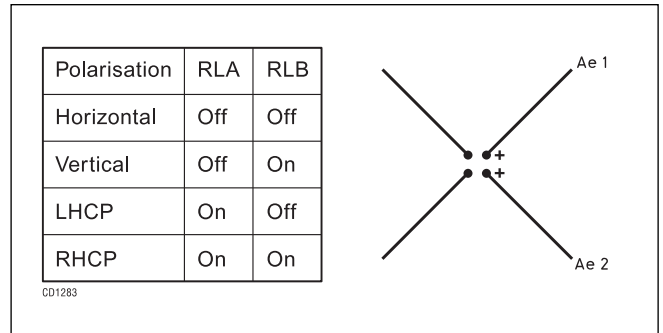

Fig 16.98: Rear view of crossed antenna with polarisation table. The radiated wave propagates into the paper

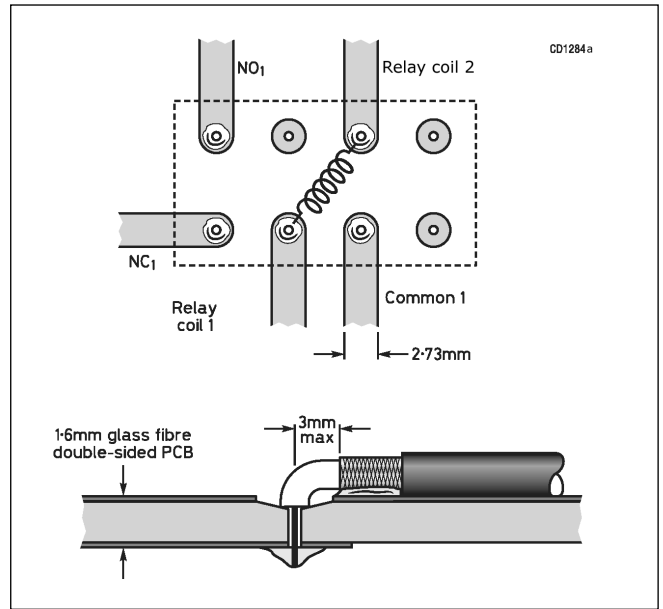

Fig 16.99: Relay and phasing/matching cable mounting details

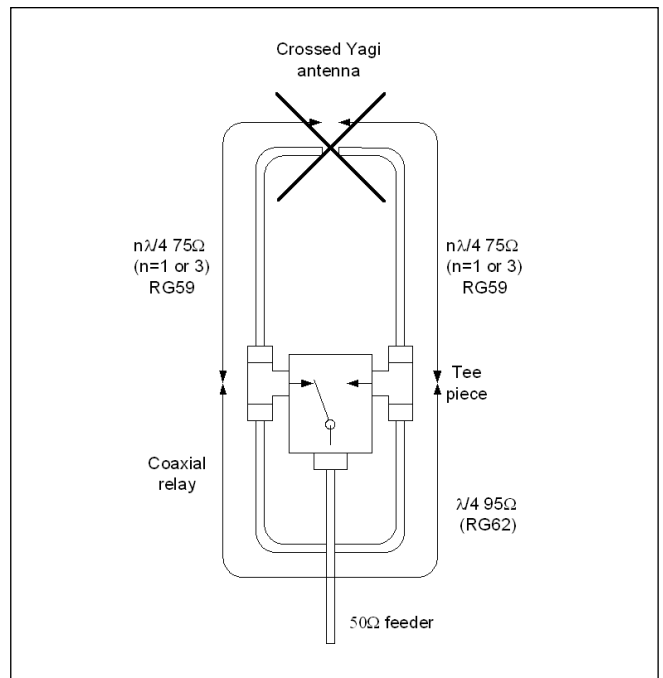

Fig 16.100: Simple switch and phasing line to produce reversible circular polarisation

## 16: PRACTICAL VHF/UHF ANTENNAS

- [5] *Yagi Antenna Design*, Dr J L Lawson, W2PV, ARRL, 1986
- [6] Yagi Optimiser YO, B Beezley, 3532 Linda Vista Drive, San Marcos, Ca 92069. Tel (619) 599-4962
- [7] 'How good are genetically designed Yagis?', R A Formato, WW1RF, *VHF Communications* Vol. 2/98 pp87-93
- [8] 'A genetically designed Yagi' R A Formato, WW1RF, *VHF Communications* Vol, 2/97 pp 116-123
- [9] YGO2, YGO3 Yagi Genetic Optimiser software may be downloaded from <http://www.si-list.net/swindex.html>
- [10] *Genetic Algorithms in Electromagnetics*, Randy L Haupt and Douglas H Werner, Wiley, 2007
- [11] 'How to Design Yagis', W1JR, *Ham Radio*, Aug 1977, pp22-30
- [12] 'Long Yagis', W2NLY and W6KQI, *QST* Jan 1956
- [13] 'Extremely long Yagi Antennas', G Hoch, DL6WU, *VHF Communications*, Mar 82, pp131-138; Apr 1977, pp204-21
- [14] 'DL6WU Yagi Designs', *VHF/UHF DX Book*, ed I White, G3SEK, DIR Publishing / RSGB 1993
- [15] [www.ifwtech.co.uk/g3sek/diy-yagi](http://www.ifwtech.co.uk/g3sek/diy-yagi). Various long Yagi designs with construction details and other information
- [16] 'The JVL LoopQuad', *Microwave Handbook*, Vol 1, M W Dixon, G3PFR, (ed) p4.7ff, RSGB
- [17] 'The GW3YDX Super Moxon' Ron Stone, GW3YDX, *RadCom* July 2010 pp 70 -71.
- [18] [www.vinecom.co.uk](http://www.vinecom.co.uk)
- [19] *Antennas*, J D Kraus, 2nd edn, McGraw-Hill, 1988, Chap 4
- [20] *Antenna Theory, Analysis and Design*, Constantine A Balanis, Harper and Row, 1928 pp204-243
- [21] 'A Quadruple Quad Antenna - an Efficient Portable Antenna for 2 Metres', M Ragaller, DL6DW, *VHF Communications* 2/1971, pp82-84
- [22] 'Analysis and Design of the Log-Periodic Dipole Antenna' *Antenna Laboratory Report No.52*, University of Illinois, USA
- [23] 'Log-Periodic Dipole Arrays', D E Isbell, *IRE Transactions on Antennas and Propagation* Vol AP-8, May 1960, pp260-267
- [24] W3DUQ, *Ham Radio*, Aug 1970
- [25] *Antennas*, J D Kraus, 2nd edn, McGraw-Hill, 1988 pp265-319
- [26] 'Helical Antennas for 435MHz', J Miller, G3RUH, *Electronics and Wireless World* Jun 1985, pp43-46
- [27] 'A Helical antenna for the 23cm Band', Hans-J Griem, DJ1SL, *VHF Communications* 3/83 pp184-189
- [28] 'Feedline Verticals for 2m & 6m', Rolf Brevig LA11C, *RadCom* Mar 2000 p36
- [29] 'The HB9CV Antenna for VHF and UHF', H J Franke, DK1PN, *VHF Communications* Feb 1969
- [30] 'Eurotek', E David, G4LQI, *RadCom*, Sep 1999 pp31-32
- [31] 'Asymmetrically Driven Antennas and the Sleeve Dipole', R W P King, *Proc IRE*, Oct 1955 pp1154-1164
- [32] 'Designing Discone Antennas', J J Nail, *Electronics* Vol 26, Aug 1953, pp167-169
- [33] 'Slim Jim Antenna', F C Judd, G2BCX, *Practical Wireless*, Apr 1978, pp899-901
- [34] 'Designing and building a 70cm repeater aerial' David Stansfield G0EUV, *RadCom* October 2010 pp54-56
- [35] 'Eurotek' *RadCom* May 1996 p59 & 61, Circular loop Eggbeater antenna
- [36] [www.observations.biz/K50E/Eggbeeater\\_2.htm](http://www.observations.biz/K50E/Eggbeeater_2.htm) (Note the spelling 'Eggbeeater' is correct). Eggbeater II omni LEO antenna
- [37] 'Resonant Quadrifilar Helix Design' C C Kilgus, *Microwave Journal*, Vol 13-12, Dec 1970, pp49-54
- [38] 'Shaped-Conical Radiation Pattern Performance of the Backfire Quadrifilar Helix', C C Kilgus, *IEEE Trans Antennas and Propagation* May 1975, pp392-397
- [39] [http://perso.wanadoo.es/dimoni/ant\\_qha.htm](http://perso.wanadoo.es/dimoni/ant_qha.htm). Construction details for a very slim quadrifilar helix antenna for 2m or 137.5MHz Note that the elements are twisted just a quarter of a turn.
- [40] [http://photos.imageevent.com/qdf\\_files/technicalgoodies/experimentersfolder/antennas/quadrifilar%20helix.pdf](http://photos.imageevent.com/qdf_files/technicalgoodies/experimentersfolder/antennas/quadrifilar%20helix.pdf). Conventional half-turn QFH for 137MHz with very detailed assembly instructions
- [41] Westlake: [www.whwestlake.co.uk](http://www.whwestlake.co.uk). Polythene and PTFE cables in many sizes and impedances, including miniature types.

### About the Author

**Peter Swallow**, G8EZE, was directly involved with the design and development of fixed and mobile antennas for 14 years, and continues to experiment with antennas for the VHF and low microwave bands to support his interest in amateur satellite communications. He has been an article reviewer for the RSGB Technical Committee since 1989 and has contributed to previous editions of the Radio Communication Handbook and VHF-UHF Handbook. He is currently a systems engineering consultant with a company specialising in communications technologies.